

Under the Paperwork Reduction Act of 1995, no persons are required to respond to a collection of information unless it displays a valid OMB control number.

UTILITY PATENT APPLICATION TRANSMITTAL <i>(Only for new nonprovisional applications under 37 CFR 1.53(b))</i>	Attorney Docket No.	DON09 P-2194
	First Inventor	Niall R. Lynam
	Title	EXTENDED FIELD OF VIEW EXTERIOR MIRROR ELEMENT FOR VEHICLE
	Express Mail Label No.	

APPLICATION ELEMENTS <i>See MPEP chapter 600 concerning utility patent application contents.</i>	ADDRESS TO: Commissioner for Patents P.O. Box 1450 Alexandria VA 22313-1450
--	--

<p>1. <input type="checkbox"/> Fee Transmittal Form. (PTO/SB/17 or equivalent)</p> <p>2. <input type="checkbox"/> Applicant claims small entity status. See 37 CFR 1.27.</p> <p>3. <input checked="" type="checkbox"/> Specification. [Total Pages ⁵⁴ _____] Both the claims and abstract must start on a new page (For information on the preferred arrangement, see MPEP § 608.01(a))</p> <p>4. <input checked="" type="checkbox"/> Drawing(s). (35 U.S.C. 113) [Total Sheets ¹⁹ _____]</p> <p>5. Inventor's Oath or Declaration. [Total Sheets ¹ _____] (including substitute statements under 37 CFR 1.64 and assignments serving as an oath or declaration under 37 CFR 1.63(e))</p> <p>a. <input type="checkbox"/> Newly executed (original or copy)</p> <p>b. <input checked="" type="checkbox"/> A copy from a prior application (37 CFR 1.63(d))</p> <p>6. <input checked="" type="checkbox"/> Application Data Sheet. *See Note below. See 37 CFR 1.76 (PTO/AIA/14 or equivalent)</p> <p>7. <input type="checkbox"/> CD-ROM or CD-R. in duplicate, large table or Computer Program (Appendix)</p> <p><input type="checkbox"/> Landscape Table on CD</p> <p>8. Nucleotide and/or Amino Acid Sequence Submission. (if applicable, items a. - c. are required)</p> <p>a. <input type="checkbox"/> Computer Readable Form (CRF)</p> <p>b. <input type="checkbox"/> Specification Sequence Listing on:</p> <p>i. <input type="checkbox"/> CD-ROM or CD-R (2 copies); or</p> <p>ii. <input type="checkbox"/> Paper</p> <p>c. <input type="checkbox"/> Statements verifying identity of above copies</p>	<p style="text-align: center;">ACCOMPANYING APPLICATION PARTS</p> <p>9. <input type="checkbox"/> Assignment Papers. (cover sheet & document(s)) Name of Assignee _____</p> <p>10. <input type="checkbox"/> 37 CFR 3.73(c) Statement. <input checked="" type="checkbox"/> Power of Attorney. (when there is an assignee)</p> <p>11. <input type="checkbox"/> English Translation Document. (if applicable)</p> <p>12. <input type="checkbox"/> Information Disclosure Statement. (PTO/SB/08 or PTO-1449) <input type="checkbox"/> Copies of citations attached</p> <p>13. <input type="checkbox"/> Preliminary Amendment.</p> <p>1 <input type="checkbox"/> Return Receipt Postcard. 4 (MPEP § 503) (Should be specifically itemized)</p> <p>15. <input type="checkbox"/> Certified Copy of Priority Document(s). (if foreign priority is claimed)</p> <p>16. <input type="checkbox"/> Nonpublication Request. Under 35 U.S.C. 122(b)(2)(B)(i). Applicant must attach form PTO/SB/35 or equivalent.</p> <p>17. <input type="checkbox"/> Other: _____</p>
---	--

19. CORRESPONDENCE ADDRESS

<input checked="" type="checkbox"/> The address associated with Customer Number:	15671	OR	<input type="checkbox"/> Correspondence address below
Name			
Address			
City	State	Zip Code	
Country	Telephone	Email	

Signature	/taf/	Date	October 15, 2013
Name (Print/Type)	Timothy A. Flory	Registration No. (Attorney/Agent)	42540

This collection of information is required by 37 CFR 1.53(b). The information is required to obtain or retain a benefit by the public which is to file (and by the USPTO to process) an application. Confidentiality is governed by 35 U.S.C. 122 and 37 CFR 1.11 and 1.14. This collection is estimated to take 12 minutes to complete, including gathering, preparing, and submitting the completed application form to the USPTO. Time will vary depending upon the individual case. Any comments on the amount of time you require to complete this form and/or suggestions for reducing this burden, should be sent to the Chief Information Officer, U.S. Patent and Trademark Office, U.S. Department of Commerce, P.O. Box 1450, Alexandria, VA 22313-1450. DO NOT SEND FEES OR COMPLETED FORMS TO THIS ADDRESS. **SEND TO: Commissioner for Patents, P.O. Box 1450, Alexandria, VA 22313-1450.**

If you need assistance in completing the form, call 1-800-PTO-9199 and select option 2.

IN THE UNITED STATES PATENT AND TRADEMARK OFFICE

Inventor : Niall R. Lynam
For : EXTENDED FIELD OF VIEW EXTERIOR MIRROR ELEMENT
FOR VEHICLE

Commissioner for Patents
P.O. Box 1450
Alexandria, VA 22313-1450

Dear Sir:

REQUEST FOR FILING CONTINUATION APPLICATION
UNDER 37 CFR 1.53(b)

This is a request for filing a continuation of U.S. patent application Serial No. 13/776,247, filed February 25, 2013, which will issue on October 22, 2013 as U.S. patent No. 8,562,157, and which is a continuation of U.S. patent application Serial No. 13/776,091, filed February 25, 2013, which is a continuation of U.S. patent application Serial No. 13/590,854, filed August 21, 2012, now U.S. Patent No. 8,550,642, which is a divisional application of U.S. patent application Serial No. 13/336,018, filed December 23, 2011, now U.S. Patent No. 8,267,534, which is a continuation of U.S. patent application Serial No. 12/911,274, filed October 25, 2010, now U.S. Patent No. 8,128,243, which is a continuation of U.S. patent application Serial No. 12/851,045, filed August 5, 2010, now U.S. Patent No. 7,934,843, which is a continuation of U.S. patent application Serial No. 12/197,666, filed August 25, 2008, now U.S. Patent No. 7,842,154, which is a division of U.S. patent application Serial No. 10/709,434, filed May 5, 2004, now U.S. Patent No. 7,420,756, which claims the benefit of U.S. provisional application, Serial No. 60/471,872, filed May 20, 2003.

Inventor : Niall R. Lynam
For : EXTENDED FIELD OF VIEW EXTERIOR MIRROR ELEMENT
FOR VEHICLE
Page : 2

1. Copy of Prior Application as Filed Which is Attached

I hereby verify that the attached papers are a copy of what is shown in my records to be the above-identified prior application, including the Declaration as originally filed (37 CFR 1.53). No amendments referred to in any Declaration filed to complete the prior application introduced new matter in that application.

The attached copy of the papers of the parent application includes 45 pages of specification, 8 pages of claims (20 claims), 1 page of Abstract, 19 sheets of drawings, and signed Declaration (1 page) and Power of Attorney (2 pages). The attached drawings are copies of the formal drawings filed in the parent applications and correspond to the drawings originally filed with the parent applications.

2. Amendments

The copy of the application includes the amendments made during prosecution of the parent applications and includes a revised/updated Cross Reference to Related Applications and new Abstract.

The attached copy includes new claims 1-20, which replace the claims of the parent patent application. Claims 1-14 correspond to withdrawn claims 41-54 of U.S. patent application Serial No. 13/776,091, filed February 25, 2013.

3. Notice Regarding Prosecution relative to Parent Application

This application is a continuation of U.S. patent application Serial No. 13/776,247, filed February 25, 2013, which is part of the continuation chain noted above. Applicants note from controlling case law that disclaimer of subject matter made during an earlier prosecution can be rescinded, permitting recapture of the

Inventor : Niall R. Lynam
For : EXTENDED FIELD OF VIEW EXTERIOR MIRROR ELEMENT
FOR VEHICLE
Page : 4

Number of claims in excess of twenty,
-0- times \$80.00 \$0.00

Filing multiple dependent claims
per application \$780.00 \$.00

Application size fee for each additional
50 sheets that exceeds 100 sheets
(-0- times \$400.00) \$0.00

Additional Fees:

Search Fee - \$600 \$600.00

Examination Fee - \$720 \$720.00

Total Filing Fee \$1,600.00

The above fees will be paid by credit card. The Commissioner is hereby authorized to charge any additional fees which may be required, or credit any overpayment, to Deposit Account No. 50-5553.

The Commissioner is hereby authorized to charge the following fees during the pendency of this application, or credit any overpayment to Deposit Account 50-5553.

- a) Any filing fees under 37 CFR 1.16 for presentation of extra claims for which full payment has not been tendered.
- b) Any patent application processing fees under 37 CFR 1.17 for which full payment has not been tendered.

6. Drawings

Nineteen (19) sheets of formal drawings are enclosed and are copies of those filed in the parent applications. The formal drawings correspond to the drawings

Inventor : Niall R. Lynam
For : EXTENDED FIELD OF VIEW EXTERIOR MIRROR ELEMENT
FOR VEHICLE
Page : 5

originally filed with the parent applications and include any revisions made and approved during prosecution of the parent applications.

7. Disclosure Statement

Applicants respectfully request that information cited in the prior parent applications be considered in the present application. An Information Disclosure Statement will be submitted that lists the cited references.

8. Inventorship Statement

With respect to the prior co-pending U.S. application from which this application claims benefit under 35 USC 120, the inventor in this application is the same, namely, Niall R. Lynam.

9. Assignment

The prior application was originally assigned to Donnelly Corporation, a corporation of the State of Michigan, located and doing business at 49 W. Third Street, Holland, Michigan 49423. That Assignment was recorded in the United States Patent and Trademark Office on August 23, 2004, at Reel 015715, Frame 0476.

10. Power of Attorney

The current Power of Attorney is to the attorneys associated with the customer number listed thereon.

Please address all future correspondence to:

Timothy A. Flory
Gardner, Linn, Burkhart & Flory, LLP
2851 Charlevoix Drive, S.E., Suite 207
Grand Rapids, MI 49546
Ph: (616) 975-5500
Fax: (616) 975-5505

Inventor : Niall R. Lynam
For : EXTENDED FIELD OF VIEW EXTERIOR MIRROR ELEMENT
FOR VEHICLE
Page : 6

11. Verification

I hereby declare further that all statements made herein of my own knowledge are true and that all statements made on information and belief are believed to be true; and further that these statements are made with the knowledge that willful false statements and the like so made are punishable by fine or imprisonment, or both, under Section 1001 of Title 18 of the United States Code, and that such willful false statements may jeopardize the validity of the application or any patent issuing thereon.

Respectfully submitted,

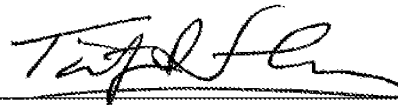

Date: October 15, 2013

Timothy A. Flory
Registration No. 42 540
Gardner, Linn, Burkhardt & Flory, LLP
2851 Charlevoix Drive, S.E., Suite 207
Grand Rapids, MI 49546
(616) 975-5500

TAF/ars

Under the Paperwork Reduction Act of 1995, no persons are required to respond to a collection of information unless it contains a valid OMB control number.

Application Data Sheet 37 CFR 1.76		Attorney Docket Number	DON09 P-2194
		Application Number	
Title of Invention	EXTENDED FIELD OF VIEW EXTERIOR MIRROR ELEMENT FOR VEHICLE		
The application data sheet is part of the provisional or nonprovisional application for which it is being submitted. The following form contains the bibliographic data arranged in a format specified by the United States Patent and Trademark Office as outlined in 37 CFR 1.76. This document may be completed electronically and submitted to the Office in electronic format using the Electronic Filing System (EFS) or the document may be printed and included in a paper filed application.			

Secrecy Order 37 CFR 5.2

<input type="checkbox"/>	Portions or all of the application associated with this Application Data Sheet may fall under a Secrecy Order pursuant to 37 CFR 5.2 (Paper filers only. Applications that fall under Secrecy Order may not be filed electronically.)
--------------------------	---

Inventor Information:

Inventor 1					<input type="button" value="Remove"/>
Legal Name					
Prefix	Given Name	Middle Name	Family Name	Suffix	
	Niall	R.	Lynam		
Residence Information (Select One) <input checked="" type="radio"/> US Residency <input type="radio"/> Non US Residency <input type="radio"/> Active US Military Service					
City	Holland	State/Province	MI	Country of Residence i	US
Mailing Address of Inventor:					
Address 1	281 Norwood Avenue				
Address 2					
City	Holland	State/Province	MI		
Postal Code	49424	Country i	US		
All Inventors Must Be Listed - Additional Inventor Information blocks may be generated within this form by selecting the Add button. <input type="button" value="Add"/>					

Correspondence Information:

Enter either Customer Number or complete the Correspondence Information section below. For further information see 37 CFR 1.33(a).			
<input type="checkbox"/> An Address is being provided for the correspondence information of this application.			
Customer Number	15671		
Email Address	flory@glbf.com	<input type="button" value="Add Email"/>	<input type="button" value="Remove Email"/>

Application Information:

Title of the Invention	EXTENDED FIELD OF VIEW EXTERIOR MIRROR ELEMENT FOR VEHICLE		
Attorney Docket Number	DON09 P-2194	Small Entity Status Claimed	<input type="checkbox"/>
Application Type	Nonprovisional		
Subject Matter	Utility		
Total Number of Drawing Sheets (if any)	19	Suggested Figure for Publication (if any)	

Application Data Sheet 37 CFR 1.76		Attorney Docket Number	DON09 P-2194
		Application Number	
Title of Invention	EXTENDED FIELD OF VIEW EXTERIOR MIRROR ELEMENT FOR VEHICLE		

Publication Information:

Request Early Publication (Fee required at time of Request 37 CFR 1.219)

Request Not to Publish. I hereby request that the attached application not be published under 35 U.S.C. 122(b) and certify that the invention disclosed in the attached application **has not and will not** be the subject of an application filed in another country, or under a multilateral international agreement, that requires publication at eighteen months after filing.

Representative Information:

Representative information should be provided for all practitioners having a power of attorney in the application. Providing this information in the Application Data Sheet does not constitute a power of attorney in the application (see 37 CFR 1.32). Either enter Customer Number or complete the Representative Name section below. If both sections are completed the customer number will be used for the Representative Information during processing.

Please Select One:	<input checked="" type="radio"/> Customer Number	<input type="radio"/> US Patent Practitioner	<input type="radio"/> Limited Recognition (37 CFR 11.9)
Customer Number	15671		

Domestic Benefit/National Stage Information:

This section allows for the applicant to either claim benefit under 35 U.S.C. 119(e), 120, 121, or 365(c) or indicate National Stage entry from a PCT application. Providing this information in the application data sheet constitutes the specific reference required by 35 U.S.C. 119(e) or 120, and 37 CFR 1.78.

Prior Application Status	Pending		Remove		
Application Number	Continuity Type	Prior Application Number	Filing Date (YYYY-MM-DD)		
	Continuation of	13776247	2013-02-25		
Prior Application Status	Pending		Remove		
Application Number	Continuity Type	Prior Application Number	Filing Date (YYYY-MM-DD)		
	Continuation of	13776091	2013-02-25		
Prior Application Status	Patented		Remove		
Application Number	Continuity Type	Prior Application Number	Filing Date (YYYY-MM-DD)	Patent Number	Issue Date (YYYY-MM-DD)
13776091	Continuation of	13590854	2012-08-21	8550642	2013-10-08
Prior Application Status	Patented		Remove		
Application Number	Continuity Type	Prior Application Number	Filing Date (YYYY-MM-DD)	Patent Number	Issue Date (YYYY-MM-DD)
13590854	Continuation of	13336018	2011-12-23	8267534	2012-09-18
Prior Application Status	Patented		Remove		

Under the Paperwork Reduction Act of 1995, no persons are required to respond to a collection of information unless it contains a valid OMB control number.

Application Data Sheet 37 CFR 1.76		Attorney Docket Number	DON09 P-2194		
		Application Number			
Title of Invention	EXTENDED FIELD OF VIEW EXTERIOR MIRROR ELEMENT FOR VEHICLE				
Application Number	Continuity Type	Prior Application Number	Filing Date (YYYY-MM-DD)	Patent Number	Issue Date (YYYY-MM-DD)
13336018	Continuation of	12911274	2010-10-25	8128243	2010-03-06
Prior Application Status		Patented		<input type="button" value="Remove"/>	
Application Number	Continuity Type	Prior Application Number	Filing Date (YYYY-MM-DD)	Patent Number	Issue Date (YYYY-MM-DD)
12911274	Continuation of	12851045	2010-08-05	7934843	2011-05-03
Prior Application Status		Patented		<input type="button" value="Remove"/>	
Application Number	Continuity Type	Prior Application Number	Filing Date (YYYY-MM-DD)	Patent Number	Issue Date (YYYY-MM-DD)
12851045	Continuation of	12197666	2008-08-25	7842154	2010-11-30
Prior Application Status		Patented		<input type="button" value="Remove"/>	
Application Number	Continuity Type	Prior Application Number	Filing Date (YYYY-MM-DD)	Patent Number	Issue Date (YYYY-MM-DD)
12197666	Division of	10709434	2004-05-05	7420756	2008-09-02
Prior Application Status		Expired		<input type="button" value="Remove"/>	
Application Number	Continuity Type	Prior Application Number	Filing Date (YYYY-MM-DD)		
10709434	non provisional of	60471872	2003-05-20		
Additional Domestic Benefit/National Stage Data may be generated within this form by selecting the Add button.					<input type="button" value="Add"/>

Foreign Priority Information:

This section allows for the applicant to claim priority to a foreign application. Providing this information in the application data sheet constitutes the claim for priority as required by 35 U.S.C. 119(b) and 37 CFR 1.55(d). When priority is claimed to a foreign application that is eligible for retrieval under the priority document exchange program (PDX) the information will be used by the Office to automatically attempt retrieval pursuant to 37 CFR 1.55(h)(1) and (2). Under the PDX program, applicant bears the ultimate responsibility for ensuring that a copy of the foreign application is received by the Office from the participating foreign intellectual property office, or a certified copy of the foreign priority application is filed, within the time period specified in 37 CFR 1.55(g)(1).

<input type="button" value="Remove"/>			
Application Number	Country ⁱ	Filing Date (YYYY-MM-DD)	Access Code ⁱ (if applicable)
Additional Foreign Priority Data may be generated within this form by selecting the Add button.			
<input type="button" value="Add"/>			

Application Data Sheet 37 CFR 1.76		Attorney Docket Number	DON09 P-2194
		Application Number	
Title of Invention	EXTENDED FIELD OF VIEW EXTERIOR MIRROR ELEMENT FOR VEHICLE		

Statement under 37 CFR 1.55 or 1.78 for AIA (First Inventor to File) Transition Applications

<input type="checkbox"/> This application (1) claims priority to or the benefit of an application filed before March 16, 2013 and (2) also contains, or contained at any time, a claim to a claimed invention that has an effective filing date on or after March 16, 2013.

Authorization to Permit Access:

<input type="checkbox"/> Authorization to Permit Access to the Instant Application by the Participating Offices
<p>If checked, the undersigned hereby grants the USPTO authority to provide the European Patent Office (EPO), the Japan Patent Office (JPO), the Korean Intellectual Property Office (KIPO), the World Intellectual Property Office (WIPO), and any other intellectual property offices in which a foreign application claiming priority to the instant patent application is filed access to the instant patent application. See 37 CFR 1.14(c) and (h). This box should not be checked if the applicant does not wish the EPO, JPO, KIPO, WIPO, or other intellectual property office in which a foreign application claiming priority to the instant patent application is filed to have access to the instant patent application.</p> <p>In accordance with 37 CFR 1.14(h)(3), access will be provided to a copy of the instant patent application with respect to: 1) the instant patent application-as-filed; 2) any foreign application to which the instant patent application claims priority under 35 U.S.C. 119(a)-(d) if a copy of the foreign application that satisfies the certified copy requirement of 37 CFR 1.55 has been filed in the instant patent application; and 3) any U.S. application-as-filed from which benefit is sought in the instant patent application.</p> <p>In accordance with 37 CFR 1.14(c), access may be provided to information concerning the date of filing this Authorization.</p>

Applicant Information:

Providing assignment information in this section does not substitute for compliance with any requirement of part 3 of Title 37 of CFR to have an assignment recorded by the Office.		
Applicant 1		<input type="button" value="Remove"/>
<p>If the applicant is the inventor (or the remaining joint inventor or inventors under 37 CFR 1.45), this section should not be completed. The information to be provided in this section is the name and address of the legal representative who is the applicant under 37 CFR 1.43; or the name and address of the assignee, person to whom the inventor is under an obligation to assign the invention, or person who otherwise shows sufficient proprietary interest in the matter who is the applicant under 37 CFR 1.46. If the applicant is an applicant under 37 CFR 1.46 (assignee, person to whom the inventor is obligated to assign, or person who otherwise shows sufficient proprietary interest) together with one or more joint inventors, then the joint inventor or inventors who are also the applicant should be identified in this section.</p>		
		<input type="button" value="Clear"/>
<input checked="" type="radio"/> Assignee	<input type="radio"/> Legal Representative under 35 U.S.C. 117	<input type="radio"/> Joint Inventor
<input type="radio"/> Person to whom the inventor is obligated to assign.		<input type="radio"/> Person who shows sufficient proprietary interest

Under the Paperwork Reduction Act of 1995, no persons are required to respond to a collection of information unless it contains a valid OMB control number.

Application Data Sheet 37 CFR 1.76		Attorney Docket Number	DON09 P-2194	
		Application Number		
Title of Invention	EXTENDED FIELD OF VIEW EXTERIOR MIRROR ELEMENT FOR VEHICLE			
If applicant is the legal representative, indicate the authority to file the patent application, the inventor is:				
Name of the Deceased or Legally Incapacitated Inventor :				
If the Applicant is an Organization check here. <input checked="" type="checkbox"/>				
Organization Name	Donnelly Corporation			
Mailing Address Information:				
Address 1	49 W. Third Street			
Address 2				
City	Holland	State/Province	MI	
Country ⁱ	US	Postal Code	49424	
Phone Number		Fax Number		
Email Address				
Additional Applicant Data may be generated within this form by selecting the Add button.				<input type="button" value="Add"/>

Non-Applicant Assignee Information:

Providing assignment information in this section does not substitute for compliance with any requirement of part 3 of Title 37 of CFR to have an assignment recorded by the Office.				
Assignee 1				
Complete this section only if non-applicant assignee information is desired to be included on the patent application publication in accordance with 37 CFR 1.215(b). Do not include in this section an applicant under 37 CFR 1.46 (assignee, person to whom the inventor is obligated to assign, or person who otherwise shows sufficient proprietary interest), as the patent application publication will include the name of the applicant(s).				
				<input type="button" value="Remove"/>
If the Assignee is an Organization check here. <input type="checkbox"/>				
Prefix	Given Name	Middle Name	Family Name	Suffix

Under the Paperwork Reduction Act of 1995, no persons are required to respond to a collection of information unless it contains a valid OMB control number.

Application Data Sheet 37 CFR 1.76		Attorney Docket Number	DON09 P-2194
		Application Number	
Title of Invention	EXTENDED FIELD OF VIEW EXTERIOR MIRROR ELEMENT FOR VEHICLE		

Mailing Address Information:			
Address 1			
Address 2			
City		State/Province	
Country i		Postal Code	
Phone Number		Fax Number	
Email Address			
Additional Assignee Data may be generated within this form by selecting the Add button.			<input type="button" value="Add"/>

Signature:

NOTE: This form must be signed in accordance with 37 CFR 1.33. See 37 CFR 1.4 for signature requirements and certifications					
Signature	/taf/	Date (YYYY-MM-DD)		2013-10-15	
First Name	Timothy	Last Name	Flory	Registration Number	42540
Additional Signature may be generated within this form by selecting the Add button.					<input type="button" value="Add"/>

This collection of information is required by 37 CFR 1.76. The information is required to obtain or retain a benefit by the public which is to file (and by the USPTO to process) an application. Confidentiality is governed by 35 U.S.C. 122 and 37 CFR 1.14. This collection is estimated to take 23 minutes to complete, including gathering, preparing, and submitting the completed application data sheet form to the USPTO. Time will vary depending upon the individual case. Any comments on the amount of time you require to complete this form and/or suggestions for reducing this burden, should be sent to the Chief Information Officer, U.S. Patent and Trademark Office, U.S. Department of Commerce, P.O. Box 1450, Alexandria, VA 22313-1450. DO NOT SEND FEES OR COMPLETED FORMS TO THIS ADDRESS. **SEND TO: Commissioner for Patents, P.O. Box 1450, Alexandria, VA 22313-1450.**

Privacy Act Statement

The Privacy Act of 1974 (P.L. 93-579) requires that you be given certain information in connection with your submission of the attached form related to a patent application or patent. Accordingly, pursuant to the requirements of the Act, please be advised that: (1) the general authority for the collection of this information is 35 U.S.C. 2(b)(2); (2) furnishing of the information solicited is voluntary; and (3) the principal purpose for which the information is used by the U.S. Patent and Trademark Office is to process and/or examine your submission related to a patent application or patent. If you do not furnish the requested information, the U.S. Patent and Trademark Office may not be able to process and/or examine your submission, which may result in termination of proceedings or abandonment of the application or expiration of the patent.

The information provided by you in this form will be subject to the following routine uses:

1. The information on this form will be treated confidentially to the extent allowed under the Freedom of Information Act (5 U.S.C. 552) and the Privacy Act (5 U.S.C. 552a). Records from this system of records may be disclosed to the Department of Justice to determine whether the Freedom of Information Act requires disclosure of these records.
2. A record from this system of records may be disclosed, as a routine use, in the course of presenting evidence to a court, magistrate, or administrative tribunal, including disclosures to opposing counsel in the course of settlement negotiations.
3. A record in this system of records may be disclosed, as a routine use, to a Member of Congress submitting a request involving an individual, to whom the record pertains, when the individual has requested assistance from the Member with respect to the subject matter of the record.
4. A record in this system of records may be disclosed, as a routine use, to a contractor of the Agency having need for the information in order to perform a contract. Recipients of information shall be required to comply with the requirements of the Privacy Act of 1974, as amended, pursuant to 5 U.S.C. 552a(m).
5. A record related to an International Application filed under the Patent Cooperation Treaty in this system of records may be disclosed, as a routine use, to the International Bureau of the World Intellectual Property Organization, pursuant to the Patent Cooperation Treaty.
6. A record in this system of records may be disclosed, as a routine use, to another federal agency for purposes of National Security review (35 U.S.C. 181) and for review pursuant to the Atomic Energy Act (42 U.S.C. 218(c)).
7. A record from this system of records may be disclosed, as a routine use, to the Administrator, General Services, or his/her designee, during an inspection of records conducted by GSA as part of that agency's responsibility to recommend improvements in records management practices and programs, under authority of 44 U.S.C. 2904 and 2906. Such disclosure shall be made in accordance with the GSA regulations governing inspection of records for this purpose, and any other relevant (i.e., GSA or Commerce) directive. Such disclosure shall not be used to make determinations about individuals.
8. A record from this system of records may be disclosed, as a routine use, to the public after either publication of the application pursuant to 35 U.S.C. 122(b) or issuance of a patent pursuant to 35 U.S.C. 151. Further, a record may be disclosed, subject to the limitations of 37 CFR 1.14, as a routine use, to the public if the record was filed in an application which became abandoned or in which the proceedings were terminated and which application is referenced by either a published application, an application open to public inspections or an issued patent.
9. A record from this system of records may be disclosed, as a routine use, to a Federal, State, or local law enforcement agency, if the USPTO becomes aware of a violation or potential violation of law or regulation.

DECLARATION (37 CFR 1.63) FOR UTILITY OR DESIGN APPLICATION USING AN APPLICATION DATA SHEET (37 CFR 1.76)

Title of Invention	EXTENDED FIELD OF VIEW EXTERIOR MIRROR ELEMENT FOR VEHICLE
<p>As the below named inventor, I hereby declare that:</p> <p>This declaration is directed to: <input type="checkbox"/> The attached application, or <input checked="" type="checkbox"/> United States application or PCT international application number <u>13/776,247</u> filed on <u>February 25, 2013</u>.</p> <p>The above-identified application was made or authorized to be made by me.</p> <p>I believe that I am the original inventor or an original joint inventor of a claimed invention in the application.</p> <p>I hereby acknowledge that any willful false statement made in this declaration is punishable under 18 U.S.C. 1001 by fine or imprisonment of not more than five (5) years, or both.</p> <p style="text-align: center;">WARNING:</p> <p>Petitioner/applicant is cautioned to avoid submitting personal information in documents filed in a patent application that may contribute to identity theft. Personal information such as social security numbers, bank account numbers, or credit card numbers (other than a check or credit card authorization form PTO-2038 submitted for payment purposes) is never required by the USPTO to support a petition or an application. If this type of personal information is included in documents submitted to the USPTO, petitioners/applicants should consider redacting such personal information from the documents before submitting them to the USPTO. Petitioner/applicant is advised that the record of a patent application is available to the public after publication of the application (unless a non-publication request in compliance with 37 CFR 1.213(a) is made in the application) or issuance of a patent. Furthermore, the record from an abandoned application may also be available to the public if the application is referenced in a published application or an issued patent (see 37 CFR 1.14). Checks and credit card authorization forms PTO-2038 submitted for payment purposes are not retained in the application file and therefore are not publicly available.</p>	
<p>LEGAL NAME OF INVENTOR</p> <p>Inventor: <u>Niall R. Lynam</u> Date (Optional): <u>April 3 2013</u></p> <p>Signature: <u>Niall Lynam</u></p>	
<p><small>Note: An application data sheet (PTO/AIA/14 or equivalent), including naming the entire inventive entity, must accompany this form. Use an additional PTO/SB/AIA01 form for each additional inventor.</small></p>	

This collection of information is required by 35 U.S.C. 115 and 37 CFR 1.63. The information is required to obtain or retain a benefit by the public which is to file (and by the USPTO to process) an application. Confidentiality is governed by 35 U.S.C. 122 and 37 CFR 1.11 and 1.14. This collection is estimated to take 1 minute to complete, including gathering, preparing, and submitting the completed application form to the USPTO. Time will vary depending upon the individual case. Any comments on the amount of time you require to complete this form and/or suggestions for reducing this burden, should be sent to the Chief Information Officer, U.S. Patent and Trademark Office, U.S. Department of Commerce, P.O. Box 1450, Alexandria, VA 22313-1450. DO NOT SEND FEES OR COMPLETED FORMS TO THIS ADDRESS. SEND TO: Commissioner for Patents, P.O. Box 1450, Alexandria, VA 22313-1450.

If you need assistance in completing the form, call 1-800-PTO-8199 and select option 2.

Under the Paperwork Reduction Act of 1995, no persons are required to respond to a collection of information unless it displays a valid OMB control number.

**TRANSMITTAL FOR POWER OF ATTORNEY TO ONE OR MORE
REGISTERED PRACTITIONERS**

NOTE: This form is to be submitted with the Power of Attorney by Applicant form (PTO/AIA/82B or equivalent) to identify the application to which the Power of Attorney is directed, in accordance with 37 CFR 1.5. If the Power of Attorney by Applicant form is not accompanied by this transmittal form or an equivalent, the Power of Attorney will not be recognized in the application.

Application Number	
Filing Date	October 15, 2013
First Named Inventor	Niall R. Lynam
Title	EXTENDED FIELD OF VIEW EXTERIOR MIRROR ELEMENT FOR VEHICLE
Art Unit	
Examiner Name	
Attorney Docket Number	DON09 P-2194

SIGNATURE of Applicant or Patent Practitioner

Signature	/taf/	Date	October 15, 2013
Name	Timothy A. Flory	Telephone	(616) 975-5500
Registration Number	42540		

NOTE: This form must be signed in accordance with 37 CFR 1.33. See 37 CFR 1.4(d) for signature requirements and certifications.

*Total of 1 forms are submitted.

This collection of information is required by 37 CFR 1.31, 1.32 and 1.33. The information is required to obtain or retain a benefit by the public which is to file (and by the USPTO to process) an application. Confidentiality is governed by 35 U.S.C. 122 and 37 CFR 1.11 and 1.14. This collection is estimated to take 3 minutes to complete, including gathering, preparing, and submitting the completed application form to the USPTO. Time will vary depending upon the individual case. Any comments on the amount of time you require to complete this form and/or suggestions for reducing this burden, should be sent to the Chief Information Officer, U.S. Patent and Trademark Office, U.S. Department of Commerce, P.O. Box 1450, Alexandria, VA 22313-1450. DO NOT SEND FEES OR COMPLETED FORMS TO THIS ADDRESS. **SEND TO: Commissioner for Patents, P.O. Box 1450, Alexandria, VA 22313-1450.**

If you need assistance in completing the form, call 1-800-PTO-9199 and select option 2.

Under the Paperwork Reduction Act of 1995, no persons are required to respond to a collection of information unless it displays a valid OMB control number.

POWER OF ATTORNEY BY APPLICANT

I hereby revoke all previous powers of attorney given in the application identified in the attached transmittal letter.

- I hereby appoint Practitioner(s) associated with the following Customer Number as my/our attorney(s) or agent(s), and to transact all business in the United States Patent and Trademark Office connected therewith for the application referenced in the attached transmittal letter (form PTO/AIA/82A or equivalent):

15671

OR

- I hereby appoint Practitioner(s) named below as my/our attorney(s) or agent(s), and to transact all business in the United States Patent and Trademark Office connected therewith for the application referenced in the attached transmittal letter (form PTO/AIA/82A or equivalent):

Name	Registration Number	Name	Registration Number

Please recognize or change the correspondence address for the application identified in the attached transmittal letter to:

- The address associated with the above-mentioned Customer Number.

OR

- The address associated with Customer Number:

OR

Firm or Individual Name

Address

City

State

Zip

Country

Telephone

Email

I am the Applicant:

- Inventor or Joint Inventor
- Legal Representative of a Deceased or Legally Incapacitated Inventor
- Assignee or Person to Whom the Inventor is Under an Obligation to Assign
- Person Who Otherwise Shows Sufficient Proprietary Interest (e.g., a petition under 37 CFR 1.46(b)(2) was granted in the application or is concurrently being filed with this document)

SIGNATURE of Applicant for Patent

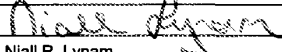
Signature		Date	April 3 2013
Name	Dr. Niall R. Lynam	Telephone	(616) 786-5148
Title and Company	Senior Vice President and Chief Technical Officer/Donnelly Corporation		

NOTE: Signature - This form must be signed by the applicant in accordance with 37 CFR 1.33. See 37 CFR 1.4 for signature requirements and certifications. Submit multiple forms for more than one signature, see below *.

- *Total of 1 forms are submitted.

This collection of information is required by 37 CFR 1.31, 1.32 and 1.33. The information is required to obtain or retain a benefit by the public which is to file (and by the USPTO to process) an application. Confidentiality is governed by 35 U.S.C. 122 and 37 CFR 1.11 and 1.14. This collection is estimated to take 3 minutes to complete, including gathering, preparing, and submitting the completed application form to the USPTO. Time will vary depending upon the individual case. Any comments on the amount of time you require to complete this form and/or suggestions for reducing this burden, should be sent to the Chief Information Officer, U.S. Patent and Trademark Office, U.S. Department of Commerce, P.O. Box 1450, Alexandria, VA 22313-1450. DO NOT SEND FEES OR COMPLETED FORMS TO THIS ADDRESS. SEND TO: Commissioner for Patents, P.O. Box 1450, Alexandria, VA 22313-1450.

If you need assistance in completing the form, call 1-800-PTO-9199 and select option 2.

EXTENDED FIELD OF VIEW EXTERIOR MIRROR ELEMENT FOR VEHICLE
CROSS REFERENCE TO RELATED APPLICATIONS

[0001] The present application is a continuation of U.S. patent application Ser. No. 13/776,247, filed Feb. 25, 2013, now U.S. Pat. No. 8,562,157, which is a continuation of U.S. patent application Ser. No. 13/776,091, filed Feb. 25, 2013 (Attorney Docket DON09 P-2048), which is a continuation of U.S. patent application Ser. No. 13/590,854, filed Aug. 21, 2012, now U.S. Pat. No. 8,550,642, which is a division of U.S. patent application Ser. No. 13/336,018, filed Dec. 23, 2011, now U.S. Pat. No. 8,267,534, which is a continuation of U.S. patent application Ser. No. 12/911,274, filed Oct. 25, 2010, now U.S. Pat. No. 8,128,243, which is a continuation of U.S. patent application Ser. No. 12/851,045, filed Aug. 5, 2010, now U.S. Pat. No. 7,934,843, which is a continuation of U.S. patent application Ser. No. 12/197,666, filed Aug. 25, 2008, now U.S. Pat. No. 7,842,154, which is a division of U.S. patent application Ser. No. 10/709,434, filed May 5, 2004, now U.S. Pat. No. 7,420,756, which claims the benefit of U.S. provisional application, Ser. No. 60/471,872, filed May 20, 2003, which are hereby incorporated herein by reference in their entirety.

FIELD OF THE INVENTION

[0002] The present invention relates generally to rearview mirror elements for a rearview mirror assembly of a vehicle and, more particularly, to exterior rearview mirror elements comprising multi-radius reflective elements.

BACKGROUND OF THE INVENTION

[0003] Typically, mirror reflective elements are formed of glass and have a reflective coating deposited thereon, such as via vacuum deposition or wet chemical silvering or the like, such as on a silver line, such as described in U.S. Pat. No. 4,737,188, which is hereby incorporated herein by reference. Polymeric reflective elements are also known, such as are described in U.S. Pat. Nos. 6,601,960; 6,409,354; 4,944,581; 4,385,804; 4,193,668; 4,666,264; and 5,483,386, which are hereby incorporated herein by reference. For such polymeric mirror reflective elements, the need exists for a hard coat or surface on the first or outer or exterior surface of the element which is contacted by the exterior elements, such as rain, road debris, or the like, or contacted, for example, by a person scraping ice

or wiping snow or condensation off the mirror element outer surface, such as during winter. A variety of hard coats have been proposed in the art, typically applied by dip coating or vacuum deposition techniques. However, a need exists for an automotive mirror reflective element which has the properties of plastic (i.e., a specific gravity roughly half that of glass), and which has a glass-like exterior surface.

[0004] Also, exterior rearview mirror reflective elements may be aspheric or multi-radius, and may typically have a less curved or substantially flat (around 2000 mm radius or thereabouts) inboard portion or surface at the inboard side of the reflective element (i.e., closer to the side body of the vehicle when the mirror assembly is mounted to the vehicle), and a more curved multi-radius portion or surface at the outboard side of the reflective element (i.e., further from the side body of the vehicle when the mirror assembly is mounted to the vehicle), in order to provide an extended field of view. It is typically desirable to have the reflective elements or substrates of such exterior mirror elements to be formed of a glass material because glass material typically provides an enhanced scratch resistance over conventional optical resins and the like.

[0005] Therefore, there is a need in the art for a mirror reflective element that overcomes the shortcomings of the prior art elements and substrates.

SUMMARY OF THE INVENTION

[0006] The present invention provides a molded wide angle or multi-radius substrate for a reflective element. The molded substrate comprises a polymeric optical resin transparent material and has a curved exterior surface, which may have a less curved/flatter or substantially flat inboard portion or surface and a more curved outboard portion or surface. The molded substrate may have an anti-abrasion film or layer, such as an ultrathin glass film, applied over the exterior surface or first surface to provide substantial protection against scratches occurring to the molded substrate. The inner surface or second surface of the reflective element substrate may have a reflective coating or layer, such as a polymeric reflective film, laminated or adhered or otherwise applied thereto.

[0007] According to an aspect of the present invention, a wide angle reflective element for a mirror assembly for a vehicle includes a wide angle substrate having an exterior surface and a glass film disposed at the exterior surface. The exterior surface of the substrate has a less curved inboard portion or surface and a more curved outboard portion or surface. The substrate comprises a polymeric resin material. The glass film is adapted to

substantially conform to the exterior surface of the wide angle substrate. The glass film comprises a glass material and has a thickness of less than approximately 0.8 mm.

[0008] According to another aspect of the present invention, a reflective element for a mirror assembly for a vehicle comprises a substrate having an exterior surface, and an anti-abrasion film applied to the exterior surface. The substrate comprises a polymeric resin material, such as a transparent optical polymeric resin material. The anti-abrasion film preferably comprises a glass material (such as a soda lime glass or a borosilicate or the like) and has a thickness of less than approximately 0.8 mm, and is flexible to conform to the exterior surface.

[0009] The substrate may be cut from a strip or sheet of molded or extruded or cast substrate material (or less preferably, may be cut from an injected molded strip or sheet). The flexible glass film may be unrolled from a reel or roll and applied to the exterior surface of the elongated strip or sheet of substrate material. The substrate, including the glass film or layer, may then be cut or otherwise formed from the elongated strip or sheet.

[0010] The substrate may comprise a wide angle substrate and/or may comprise a multi-radius exterior surface having a less curved inboard portion or surface and a more curved outboard portion or surface.

[0011] A reflective film or layer may be applied to the inner surface or side of the substrate or strip opposite the exterior surface. The reflective film may comprise a polymeric reflective film laminated or otherwise adhered or applied to the inner side of the substrate or strip. The reflective film may comprise an all polymer-thin-film multilayer, high reflective mirror film comprising multiple coextrusion of many plastic layers to form a highly reflective mirror film.

[0012] Optionally, a reflective film or layer may be applied to the exterior surface of the substrate or sheet or strip, and the glass film or layer or sheet may be applied over the reflective film layer. In such an application, the substrate acts as a support or backing plate for the reflective film or layer and the glass film or layer, whereby optical clarity / transparency of the substrate material is not necessary.

[0013] According to another aspect of the present invention, a method for forming a reflective element substrate for a mirror assembly of a vehicle comprises generally continuously forming an elongated strip or sheet of substrate material and applying a substantially transparent functional film, such as an anti-abrasion film or a hydrophilic film

or a hydrophobic film or the like, to a surface of the elongated strip sheet. The substrate material may comprise a transparent optical polymeric resin. The functional film is preferably unrolled from a reel or roll of film and applied to the surface of the elongated strip or sheet generally continuously as the strip or sheet is formed or extruded or cast or molded. Preferably, multiple mirror element shapes or mirror element substrates may be cut or otherwise formed from the elongated sheet after the functional film is applied to the surface of the strip or sheet.

[0014] The functional or anti-abrasion film may comprise an ultrathin glass material which is sufficiently flexible to be provided in a reel or roll (or in a sheet that is flexible and conformable to a bent substrate). The substrates may be formed with a wide angle exterior surface or a multi-radius exterior surface. The anti-abrasion film may be sufficiently flexible to conform to the wide angle or multi-radius or curved exterior surface.

[0015] A reflective film, such as a polymeric reflective film or the like, may be applied to the opposite surface of the substrate or sheet or strip. The reflective film may be sufficiently flexible to be provided in a reel or roll form (or in a sheet that is flexible and conformable to a bent substrate) for unrolling the reflective film as the film is generally continuously applied to the surface of the generally continuously formed sheet or strip.

[0016] Therefore, the present invention provides a molded wide angle or multi-radius single substrate for a rearview mirror assembly which has an anti-abrasion or anti-scratch film or layer applied to the curved, wide angle or multi-radius exterior surface of the substrate. The anti-abrasion film preferably comprises an ultrathin glass film or sheet to provide enhanced scratch resistance. The molded substrate may have a reflective film or layer laminated or applied to the inner surface opposite the exterior surface.

[0017] These and other objects, advantages, purposes and features of the present invention will become apparent upon review of the following specification in conjunction with the drawings.

BRIEF DESCRIPTION OF THE DRAWINGS

[0018] FIG. 1 is a perspective view of an exterior rearview mirror assembly in accordance with the present invention;

[0019] FIG. 2 is a perspective view of a wide angle or multi-radius reflective element in accordance with the present invention;

- [0020] FIG. 3 is a sectional view of the wide angle or multi-radius reflective element taken along the line III-III in FIG. 2;
- [0021] FIG. 4 is a sectional view similar to FIG. 3, showing a wide angle or multi-radius reflective element in accordance with the present invention with a reflective film or layer applied to the exterior surface of the element and an anti-abrasion film or layer applied over the reflective film or layer;
- [0022] FIG. 5 is a diagram showing the extruding, coating and cutting processes for manufacturing a prismatic mirror reflective element in accordance with the present invention;
- [0023] FIG. 5A is an elevation of the extruder of FIG. 5, showing the wedge shape of the extruded strip and reflective element substrate;
- [0024] FIG. 6 is a plan view of the extruded strip showing the cut out shapes of the reflective element cut from the extruded strip;
- [0025] FIG. 7 is a sectional view of the reflective element formed by the process shown in FIG. 5;
- [0026] FIG. 8 is a diagram showing an alternate process for manufacturing a prismatic mirror reflective element in accordance with the present invention, where a strip of substrate material is cast and formed via a caster and float section;
- [0027] FIG. 9 is a perspective view of an automobile equipped with exterior sideview mirror assemblies according to this present invention;
- [0028] FIG. 10 is a top plan partial fragmentary view of the driver's side exterior rearview mirror assembly of FIG. 9;
- [0029] FIG. 11 is an enlarged sectional view of a plano-multiradius reflective element assembly of the mirror assembly in FIG. 10;
- [0030] FIG. 12 is an enlarged sectional view of a demarcation element of the plano-multiradius reflective element assembly of FIG. 11;
- [0031] FIGS. 13A-13H illustrate views of various locations for a plano reflective element and an auxiliary reflective element according to this present invention;
- [0032] FIG. 14 is a sectional view of a second embodiment of a plano reflective element assembly according to the present invention including a demarcation element formed as a dividing wall in a backing plate element;
- [0033] FIG. 14A is a cross-section taken along line XX of FIG. 14;

- [0034] FIG. 14B is a cross-sectional view taken along line YY of FIG. 14;
- [0035] FIG. 15 is a schematic of a third embodiment of a plano-auxiliary reflective element assembly according to this present invention;
- [0036] FIG. 16 is a front elevation view of another embodiment of a plano reflective element assembly according to the present invention;
- [0037] FIG. 17 is an exploded perspective view of the plano reflective element assembly of FIG. 16;
- [0038] FIG. 18 is an end view of the plano reflective element assembly of FIG. 16 as viewed from line XVIII--XVIII of FIG. 16;
- [0039] FIG. 19 is a top view of the plano reflective element assembly of FIG. 16 as viewed from line XIX--XIX of FIG. 16;
- [0040] FIG. 20 is a schematic representation of the plano reflective element assembly of FIG. 16 illustrating the orientation of the reflective element;
- [0041] FIG. 21 is another schematic representation of the orientation of the reflective elements of the plano reflective element in FIG. 16;
- [0042] FIG. 22 is a diagram illustrating the range of viewing of the reflective elements of the plano reflective element assembly of FIG. 16;
- [0043] FIG. 23 is a perspective view of another embodiment of an exterior rearview mirror system of the present invention;
- [0044] FIG. 24 depicts a cross-sectional view of another electrochromic mirror construction according to the present invention, and in this construction, a secondary weather barrier 412 has been applied to the joint at which sealing means 405 joins substrates 402, 403;
- [0045] FIGS. 25A, 25B and 25C depict the orientation of the substrates in different constructions of the electrochromic mirrors and electrochromic devices of the present invention, with FIG. 25A depicting a perpendicular displacement of the first substrate and the second substrate, FIG. 25B depicting a lateral displacement and a perpendicular displacement of the first substrate and the second substrate, and FIG. 25C depicting an arrangement of the first substrate and the second substrate, wherein the dimensions of the length and width of the first substrate are slightly greater than those of the second substrate, and in this arrangement, the peripheral edge of the first substrate extends beyond the peripheral edge of the second substrate; and

[0046] FIGS. 26A and 26B depict cross-sectional views of electrochromic devices, which illustrate different seal constructions that may be employed in accordance with the present invention.

DESCRIPTION OF THE PREFERRED EMBODIMENTS

[0047] Referring now to the drawings and the illustrative embodiments depicted therein, an exterior rearview mirror assembly 10 includes a reflective element 12 mounted at a casing 14, which is mounted at an exterior portion of a vehicle 16 (FIG. 1). Reflective element 12 may provide an enhanced field of view or wide angle field of view to a driver or occupant of the vehicle and may comprise a single reflective element substrate 18 having an inner surface 18a and an opposite exterior surface 18b (FIGS. 2 and 3). The exterior surface 18b comprises a less curved or substantially flat inboard portion or surface 18c and a more curved outboard portion or surface 18d, as discussed below. The substrate 18 may have an anti-abrasion coating or layer or film 20, such as an ultrathin glass coating or layer or film, laminated or deposited or otherwise applied to the exterior surface 18b, and may have a reflective coating or layer 22 laminated or applied to the inner surface 18a, as also discussed below. Aspects of the reflective element of the present invention may be suitable for use in a reflective element for an exterior rearview mirror assembly (as shown in FIG. 1) and/or a reflective element for an interior rearview mirror assembly (not shown).

[0048] Reflective element 12 may comprise an aspheric or multi-radius or wide angle single element reflective element substrate. The reflective element 12 may provide a field of view similar to the plano-auxiliary reflective element assembly disclosed in U.S. Pat. Nos. 6,522,451 and 6,717,712, which are hereby incorporated herein by reference.

[0049] As illustrated in FIG. 9 from U.S. Pat. No. 6,717,712, incorporated above, passenger automobile 110 (which may be a sedan, a station-wagon, a sports car, a convertible, a minivan, a sports utility vehicle, a pick-up truck or a similar passenger carrying non-commercial, personal transportation automobile) includes an interior rearview mirror assembly 127 positioned within interior vehicle cabin 125. Interior vehicle cabin 125 further includes a steering wheel 116, a driver seat 129 positioned at steering wheel 116, a front passenger seat 121 adjacent to driver seat 129 in the front portion of cabin 125, and a rear passenger seat 123 in the rear portion of cabin 125. Automobile 110 further includes a driver-side exterior sideview mirror assembly 112 and a passenger-side exterior sideview mirror assembly 114, each adapted for attachment to opposing sides of

automobile body 111, most preferably adjacent to the seating position of the driver seated in driver seat 129 for driver-side assembly 112 and adjacent to the front passenger seat 121 for passenger-side assembly 114. Exterior sideview mirrors, mounted as shown in FIG. 9 close to the driver seating location, are commonly referred to as door-mounted exterior sideview mirror assemblies. Driver-side exterior sideview mirror assembly 112 includes, as illustrated in FIG. 10, a plano-multiradius exterior sideview reflective element assembly 130. Plano-multiradius reflective element assembly 130 is mounted to a reflective element positioning actuator 136. The orientation of plano-multiradius reflective element assembly 130, and hence its rearward field of view, is adjustable by actuator 136 in response to control 137. Control 137 can comprise a handset control that allows the driver manually move the orientation of plano-multiradius reflective element assembly 130 within exterior mirror housing 140 (such as by a lever control or by a cable control) and hence reposition the rearward field of view of plano-multiradius reflective element assembly 130. Alternately, when actuator 136 comprises an electrically actuated actuator that is electrically operable incorporating at least one motor, control 137 can comprise a switch (which, preferably, is operable under control of the driver seated in cabin 125) or control 137 can comprise a memory controller, as known in the automotive mirror art, that controls actuator 136 to move the position of plano-multiradius reflective element assembly 130 to a pre-set orientation that suits the rearward field of view preference of an individual driver. Actuator 136 is mounted to bracket 138 which attaches to vehicle body side 111. Plano-multiradius reflective element assembly 130 is positionable by actuator 136 within exterior mirror housing 140.

[0050] Plano-multiradius reflective element assembly 130, as shown in FIG. 11, comprises a plano element 150 and a separate multiradius element 155. Preferably, plano element 150 is adjacent to multiradius element at a joint. At their joint, plano element 150 and separate multiradius element 155 can touch leaving substantially no gap or space therebetween, or plano element 150 and separate multiradius element 155 can be spaced apart at their joint by a space or gap, as in FIG. 11. Plano element 150 and multiradius element 155 are both mounted to surface 159 of, and are both supported by, a single backing plate element 160. Plano element 150 and multiradius element 155 are demarcated apart by demarcation element 165. Surface 161 of backing plate element 160 is preferably adapted to attach, such as by attachment member 164, to actuator 136 when

plano-multiradius reflective element assembly 130 is mounted in driver-side exterior sideview mirror assembly 112 (and/or in passenger-side exterior side view mirror assembly 114) such that plano element 150 and multiradius element 155 are adjusted and positioned in tandem and simultaneously when the driver (or alternatively, when a mirror memory system, as is conventional in the rearview mirror arts) activates actuator 136 to reposition the rearward field of view of plano-multiradius reflective element assembly 130. Thus, since elements 150, 155 are part of plano-multiradius reflective element assembly 130, movement of plano-multiradius reflective element assembly 130 by actuator 136 simultaneously and similarly moves plano element 150 and multiradius element 155.

[0051] Plano element 150 preferably comprises a flat reflector-coated glass substrate having unit magnification, and comprises a reflective surface through which the angular height and width of the image of an object is equal to the angular height and width of the object when viewed at the same distance (except for flaws that do not exceed normal manufacturing tolerances). Plano element 150 may comprise a conventional fixed reflectance mirror reflector or it may comprise a variable reflectance mirror reflector whose reflectivity is electrically adjustable. For example, plano element 150 may comprise a flat glass substrate coated with a metallic reflector coating such as a chromium coating, a titanium coating, a rhodium coating, a metal alloy coating, a nickel-alloy coating, a silver coating, an aluminum coating (or any alloy or combination of these metal reflectors). The metal reflector coating of plano element 150 may be a first surface coating (such as on surface 166) or a second surface coating (such as on surface 167), as such terms are known in the mirror art. The reflector coating on plano element 150 may also comprise a dielectric coating, or a multilayer of dielectric coatings, or a combination of a metal layer and a dielectric layer to form automotive mirror reflectors as known in the automotive mirror art. If a variable reflectance reflector element, plano element 150 preferably comprises an electro-optic reflector element and, most preferably, an electrochromic reflector element.

[0052] When mounted into exterior side view mirror assembly 112 and/or 114, plano-multiradius reflective element assembly 130 is preferably orientated so that at least a portion of (more preferably a substantial portion of) the reflector surface of plano element 150 is positioned closer to the vehicle body (and hence to the driver) than any portion of the reflector surface of multiradius element 155. Thus, and referring to FIG. 11, side A of

plano element 150 of plano-multiradius reflective element assembly 130 is positioned closer to the driver than side D of multiradius element 155 when plano-multiradius reflective element assembly 130 is mounted on an automobile. Also, when mounted into exterior side view mirror assembly 112 and/or 114, surfaces 166, 168 of plano-multiradius reflective element assembly 130 face rearwardly in terms of the direction of vehicle travel.

[0053] Multiradius element 155 of plano-multiradius reflective element assembly 130 preferably comprises a curved/bent mirrored glass substrate. The degree of curvature preferably increases (and hence the local radius of curvature decreases) across the surface of multiradius element 155 with the least curvature (largest radius of curvature) occurring at the side of multiradius element 155 (side C in FIG. 11) positioned adjacent its joint to plano element 150 when both are mounted on backing plate element 160. Thus, and referring to FIG. 11, the local radius of curvature at side C of multiradius element 155, when mounted on backing plate element 160, is larger than at side D. Also, the local radius of curvature preferably progressively decreases across multiradius element 155 from side C to side D. Preferably, the local radius of curvature at side C of multiradius element 155 is at least about 1000 mm; more preferably is at least about 2000 mm and most preferably is at least about 3000 mm whereas the local radius of curvature at side D of multiradius element 155 is, preferably, less than about 750 mm, more preferably less than about 350 mm; most preferably less than about 150 mm. Preferably, multiradius element 155 comprises a bent glass substrate with radii of curvature in the range of from about 4000 mm to about 50 mm. The multiradius prescription for the multiradius element to be used in a particular exterior mirror assembly can vary according to the specific field of view needs on a specific automobile model.

[0054] The total field of view rearwardly of the automobile of the plano-auxiliary reflective element assembly (which is a combination of the field of view of the plano reflective element and of the auxiliary reflective element) preferably generally subtends an angle of at least about 20 degrees (and more preferably, generally subtends an angle of at least about 25 degrees and most preferably, generally subtends an angle of at least about 30 degrees) with respect to the side of an automobile to which is attached an exterior sideview mirror assembly equipped with the plano-auxiliary reflective element assembly.

[0055] Multiradius element 155 may comprise a conventional fixed reflectance mirror reflector or it may comprise a variable reflectance mirror reflector whose reflectivity is

electrically adjustable. For example, multiradius element 155 may comprise a flat glass substrate coated with a metallic reflector coating such as a chromium coating, a titanium coating, a rhodium coating, a metal alloy coating, a nickel-alloy coating, a silver coating, an aluminum coating (or any alloy or combination of these metal reflectors). The metal reflector coating of multiradius element 155 may be a first surface coating (such as on surface 168) or a second surface coating (such as on surface 169), as such terms are known in the mirror art. The reflector coating on multiradius element 155 may also comprise a dielectric coating, or a multilayer of dielectric coatings, or a combination of a metal layer and a dielectric layer to form automotive mirror reflectors as known in the automotive mirror art. If a variable reflectance reflector element, multiradius element 155 preferably comprises an electro-optic reflector element and, most preferably, an electrochromic reflector element.

[0056] Also, it is preferable that the thickness of plano element 150 and multiradius element 155 be substantially the same in dimension so that their respective outer surfaces, 166 and 168, are substantially coplanar so that a driver can readily view images in either or both elements. The thickness dimension of elements 150, 155 is determined by the thickness of the substrate (or in the case of laminate-type electrochromic reflective elements, the thickness of the two substrates between which the electrochromic medium is disposed). For example, plano element 150 and/or multiradius element 155 can comprise a reflector coated glass substrate or panel of thickness preferably equal to or less than about 2.3 mm, more preferably equal to or less than about 1.6 mm, most preferably equal to or less than about 1.1 mm. Use of a thinner substrate is beneficial in terms of improving the overall stability/vibration performance of the image seen in plano-multiradius reflective element assembly 130 when mounted to an automobile.

[0057] The reflector area of plano element 150 is preferably larger than that of multiradius element 155. Preferably, the width dimension of plano element 150 is larger than the width dimension of multiradius element 155 (both width dimensions measured at their respective widest dimension and with the width of the respective element being gauged with the respective element oriented as it would be orientated when mounted on the automobile). Thus, and referring to FIG. 11, the distance from side A to side B of plano element 150 is larger than the distance from side C to side D of multiradius element 155. Thus, the ratio of the width of plano element 150 to the width of multiradius element 155 is

preferably greater than 1; more preferably greater than 1.5; most preferably greater than 2.5 in order to provide a large, unit magnification plano element 150 as the principal rear viewing portion of plano-multiradius reflective element assembly 130 and providing multiradius element 155 as a smaller, auxiliary, separate, wide-angle viewing portion of plano-multiradius reflective element assembly 130. For plano-multiradius reflective element assemblies to be mounted to the exterior sideview assemblies of passenger automobiles used non-commercially and for non-towing purpose, the width of plano element 150 (at its widest dimension) is preferably in the range of from about 50 mm to about 225 mm; more preferably in the range of from about 75 mm to about 175 mm; most preferably in the range of from about 100 mm to about 150 mm.

[0058] Backing plate element 160 is preferably a rigid polymeric substrate capable of supporting plano element 50 and multiradius element 155. Backing plate element 160 comprises a flat portion (generally between E and F as shown in FIG. 11) that corresponds to and is aligned with plano element 150. Backing plate element 60 also comprises a curved portion (generally between G and H as shown in FIG. 11) that corresponds to and is aligned with multiradius element 155. Preferably, curved portion G-H of multiradius element 155 is fabricated with a multiradius prescription that is substantially the same as the multiradius prescription of multiradius element 155. Backing plate element 160 is formed as a single element to which elements 150 and 155 are separately attached. Preferably, backing plate element 160 is formed by injection molding of a thermoplastic or a thermosetting polymer resin. Materials suitable to use for backing plate element 160 include unfilled or filled polymeric materials such as glass and/or mineral filled nylon or glass and/or mineral filled polypropylene, ABS, polyurethane and similar polymeric materials. For example, backing plate element 160 can be formed of ABS in an injection molding operation. Plano element 150 can be cut from a stock lite of flat chromium mirror-coated 1.6 mm thick glass. Multiradius element 155 can be cut from a stock lite of multiradiusly-bent chromium mirror-coated 1.6 mm thick glass. Plano element 150 and multiradius element 155 can then be attached (such as by an adhesive attachment such as an adhesive pad or by mechanical attachment such by clips, fasteners or the like) to the already molded backing plate element 160. Alternatively, plano element 150 and multiradius element 155 can each be individually loaded into an injection molding tool. Once loaded, a polymeric resin (or the monomers to form a polymeric resin) can be

injected into the mold in order to integrally form backing plate element 160 with elements 150, 155 integrally molded thereto. Integral molding of the backing plate element to plano element 150 and multiradius element 155 (along with any other elements such as the demarcation element 165) in a single integral molding operation, is a preferred fabrication process for plano-multiradius reflective element assembly 130.

[0059] Plano-multiradius reflective element assembly 130 further preferably includes demarcation element 165 that functions to delineate and demarcate the plano region of the assembly from the wide-angle, multiradius region and also preferably functions to prevent ingress of debris, dirt, water and similar contaminants (such as road splash, car wash spray, rain, snow, ice, leaves, bugs and similar items that plano-multiradius reflective element assembly 130 would be subject to when mounted and used on an automobile) into any gap between plano element 150 and multiradius element 155 when both are attached to backing plate element 160. Optionally, at least a portion of demarcation element 165 can be disposed in any gap between plano element 150 and multiradius element 155 at their joint on backing plate element 160. Preferably, demarcation element 165 is formed of a polymeric material that is dark colored (such as black or dark blue or dark brown or dark grey or a similar dark color) such as a dark colored polypropylene resin or a dark colored nylon resin or a dark colored polyurethane resin or a dark colored polyvinyl chloride resin or a dark colored silicone material. Most preferably demarcation element 165 is formed of an at least partially elastomeric material (such as silicone, or EPDM, or plasticized PVC or the like) in order to provide a degree of vibration dampening for elements 150, 155. As shown in FIG. 12, demarcation element 165 optionally includes a crown portion 170 that includes wing portions 173, 173' and a stem portion 171. Stem portion 171 preferably has a cross-sectional width CCC of less than about 4 mm, more preferably less than about 3 mm and, most preferably less than about 2 mm. Crown portion 170 preferably is dimensioned to not protrude substantially beyond surfaces 166, 168 of elements 150, 155 when demarcation element 165 is installed between elements 150 and 155. Also, wings 173, 173' are preferably dimensioned to protrude (most preferably slightly) onto surfaces 166, 168 of elements 150, 155 when demarcation element 165 is installed between elements 150 and 155 in order to provide a weather barrier seal and/or to at least partially accommodate any dimensional tolerances of elements 150, 155 that could lead to variation in the inter-element gap between sides C

and B. While the demarcation element shown in FIG. 12 is one embodiment, other constructions are possible including a demarcation element that has minimal or no crown portion. Likewise, a demarcation element can have little or no stem portion, especially when the joint between plano element 150 and multiradius element 155 includes no gap to receive a stem. Also, where a gap at the plano to multiradius joint exists, any stem of the demarcation element can at least partially be disposed in such gap so as to at least partially fill the gap (or it can optionally substantially fill the gap). Optionally, demarcation element 165 is fabricated by injection molding of a polymeric resin. After plano element 150 and multiradius element 155 have been attached to backing plate element 160, a separately formed demarcation element 165 can then be inserted (and secured such as by an adhesive or by a mechanical attachment such as by a fastener) into a space between elements 150 and 155. Note that, optionally, side B of plano element 150 and side C of multiradius element 155 can touch (leaving substantially no gap or space therebetween). In such a situation, demarcation element 165 can comprise a dark colored strip such as of a tape or of a plastic film that covers the joint between elements 150 and 155. Alternatively, demarcation element 165 can comprise a preferably dark-colored paint, lacquer, caulk or similar material that can be applied to, and that can preferably fill into, the joint between elements 150 and 155. The width of the portion of demarcation element 165 that is visible to the driver is preferably less than about 4 mm, more preferably less than about 3 mm and most preferably less than about 2 mm, but is equal to or greater than about 0.5 mm, more preferably is equal to or greater than about 0.75 mm, most preferably is equal to or greater than about 1 mm in order to provide adequate demarcation of the plano region from the multiradius radius region without unduly obscuring the rearward field of view of the respective elements. Optionally, demarcation element 165 can be formed as part of backing plate element 160 such as by forming demarcation element 165 as a wall structure of the backing plate element that partitions backing plate element 160 into two regions: A first region adapted to receive plano reflective element 150 and a separate and adjacent second region adapted to receive multiradius reflective element 155.

[0060] Thus, and referring to FIG. 14, a second embodiment of plano-multiradius reflective element assembly 130' may include a backing plate element 160' which comprises a plate molded from a polymer resin (such as a polyolefin such as polypropylene or such as ABS or nylon) with a demarcation element 165' that is molded as a wall structure that partitions

backing plate element 165' into a first region (from CC to BB) adapted to receive and accommodate plano reflective element 150' and into a second region (from BB to AA) adapted to receive and accommodate wide-angle optic multiradius reflective element 155'. Note that section AA to BB of backing plate element 160' is angled to section BB to CC. Such angling of the auxiliary reflective element relative to the plano element can be advantageous in allowing the auxiliary reflective element view a portion of the road adjacent the automobile that is in a blind spot of the plano reflective element. In this regard, it is preferable that the multiradius element be angled away from the plane of the plano element, as shown in FIG. 14 by the angling of section AA to BB to section BB to CC.

[0061] Preferably, demarcation element 165 is formed in an integral molding operation, along with formation of backing plate element 160, and attachment of elements 150, 155 thereto. For example, plano element 150 and multiradius element 155 can each be individually loaded into an injection molding tool. Once loaded, a polymeric resin (or the monomers to form a polymeric resin) can be injected into the mold in order to integrally form backing plate element 160 with elements 150, 155 integrally molded thereto and, in the same molding operation and in the same tool, also form by molding the demarcation element. Integral molding of the backing plate element to plano element 150 and multiradius element 155 along with creation in the single molding operation of demarcation element 165 (along with any other elements such as attachment member 164) in a single integral molding operation, is a preferred fabrication process for plano-multiradius reflective element assembly 130. By loading all the sub components of plano-multiradius reflective element assembly 130 into a molding tool, and then injecting polymeric resin to form the backing plate, demarcation member and any attachment member, a substantially complete or fully complete plano-multiradius reflective element assembly can be unloaded from the tool at the completion of the integral molding operation (as known in the molding art), thus enabling economy in manufacturing and accommodation of any dimensional tolerances in the sub components. Where integral molding is so used, it is preferable to use a reactive molding operation such as reactive injection molding of a urethane as such reactive injection molding operations occur at relatively modest temperatures.

[0062] Plano element 150 and/or multiradius element 155 can comprise a heater element, as known in the automotive mirror art, that is operable to deice/demist surfaces 166, 168.

Such heater elements are conventional and can comprise a positive temperature coefficient heater pad, a resistive heater element and/or a conductive coating. Plano element 150 and/or multiradius element 155 can also optionally comprise a scatterproofing member, as known in the automotive mirror art, such as an adhesive tape, to enhance safety in an accident.

[0063] Also, plano element 150 and/or multiradius element 155 can comprise a variable reflectance electro-optic element such as an electrochromic mirror reflector. Thus, both element 150 and element 155 can comprise an electrochromic mirror element or either of element 150 and element 155 can comprise an electrochromic mirror element and the other can comprise a fixed reflectance non-variable reflectance mirror element such as a metal reflector coated glass panel such as a chromium coated glass substrate. Also, if both plano element 150 and multiradius element 155 comprise an electro-optic element such as an electrochromic mirror element capable of electrically dimmable reflectivity, both elements 150, 155 can dim together and in tandem under control of a common dimming control signal (typically provided by an electro-optic automatic dimming interior mirror assembly mounted in the cabin of the automobile and equipped with photosensors to detect incident glare and ambient light). Alternately, if both plano element 150 and multiradius element 155 comprise an electrooptic element such as an electrochromic mirror element capable of electrically dimmable reflectivity, element 150 can dim independently of element 155 (such as is disclosed in U.S. Pat. No. 5,550,677, the entire disclosure of which is incorporated by reference in U.S. Pat. No. 6,717,712, incorporated herein above). If either or both of elements 150, 155 comprise an electrochromic element, preferably, the electrochromic reflective element comprises a front substrate and a rear substrate with an electrochromic medium disposed between, such as a solid polymer matrix electrochromic medium such as is disclosed in U.S. patent application Ser. No. 09/350,930, filed Jul. 12, 1999, now U.S. Pat. No. 6,154,306, or such as is disclosed in U.S. Pat. Nos. 5,668,663; 5,724,187; 5,910,854; and 5,239,405, the entire disclosures of which are incorporated by reference in U.S. Pat. No. 6,717,712, incorporated herein above. Most preferably, in such laminate-type electrochromic mirror reflective elements, the front substrate comprises a glass plate of thickness less than about 1.6 mm, most preferably about 1.1 mm thickness or lower, and the rear substrate comprises a glass plate of thickness equal to or greater than about 1.6 mm, more preferably greater than about 1.8

mm thickness, most preferably equal to or greater than about 2.0 mm thickness. The rearmost surface of the rear substrate (the fourth surface as known in the mirror art) is reflector coated with a high reflecting metal film such as of aluminum or silver, or an alloy of aluminum or silver. Most preferably, the front-most surface of the rear substrate (the third surface as known in the mirror art) is reflector coated with a high reflecting metal film such as of aluminum or silver, or an alloy of aluminum or silver.

[0064] Backing plate element 165 of plano-multiradius reflective element assembly 130 is optionally equipped on its rearmost surface with attachment member 164 to facilitate attachment to the reflector-positioning actuator of the exterior sideview mirror assembly that plano-multiradius reflective element assembly 130 is mounted to. Attachment of plano-multiradius reflective element assembly 130 to the actuator can be by mechanical attachment such as by a tab, clip or fastener, or may be by adhesive attachment such as by a silicone adhesive, a urethane adhesive or a similar adhesive material such as a tape coated on both surfaces with a pressure sensitive adhesive to form a "double-sticky" tape. The exterior sideview mirror assembly, on whose mirror reflector-positioning actuator the plano-multiradius reflective element assembly is mounted, can be a fixedly attached exterior sideview mirror assembly, a break-away exterior sideview mirror assembly and a powerfold exterior sideview mirror assembly, as known in the automotive mirror art.

[0065] FIGS. 13A-13H shows various arrangements of multiradius reflective element 155 relative to its adjacent plano reflective element 150 (with demarcation element 165 disposed at their joint). In FIGS. 13A, 13B, 13C, 13E and 13F, plano element 150 is mounted wholly inboard of multiradius element 155. Thus, in FIGS. 13A, 13B, 13C, 13E and 13F, plano element 150 would be disposed closer to the vehicle body (and hence to the driver) than multiradius element 155 when plano-multiradius reflective element assembly 130 was mounted in an exterior sideview mirror attached to a side of an automobile. Therefore, in FIGS. 13A, 13B, 13C, 13E and 13F, plano element 150 would be mounted inboard relative to the side of the automobile and multiradius element 155 would be mounted outboard relative to the side of the automobile. In general, the location of the multiradius reflective element in the outboard, upper portion of the plano-multiradius reflective element assembly, as in FIGS. 13B and 13E, is preferred as this allows the plano portion provide a desired rearward field of view along the side of the vehicle. The configuration as shown in FIG. 13G (where the multiradius reflective element is along the

inboard side of the assembly) is also desirable as this allows the driver view the side of the vehicle (something many drivers desire in order to have a frame of reference for their rearward field of view) while facilitating having a wide field of view for the plano portion.

[0066]

Unlike trucks, busses and commercial vehicles the size of an exterior sideview mirror assembly suitable for use on an automobile (and especially when the automobile is not towing a trailer or the like) is restricted. Automobiles generally are non-commercial vehicles intended for personal transportation. Automobiles typically carry 5 passengers or less, although minivans and large sports utility vehicles (which are classified herein as automobiles) can have seat accommodation for up to 10 passengers (although accommodation for 7 passengers or less is more common). The tandem mounting of a plano element of unit magnification and a separate auxiliary element onto a common, single backing plate element, and the mounting of this backing plate element onto an actuator of an exterior sideview mirror assembly so that a driver can simultaneously and similarly move the auxiliary element and the plano element so as to position their respective rearward fields of view, and to achieve this within the relatively restricted space available in a standard automobile-sized exterior sideview mirror assembly is an important element of this present invention. By utilizing a plano element of unit magnification in the plano-multiradius reflective element assembly, and by sizing the reflector area of the plano element larger than the reflector area of the multiradius element and, preferably, by sizing the reflector area of the plano element at a sufficiently large size that the rearward field of view provided by the plano element alone meets and satisfies the minimum field of view requirement mandated by an automaker specification and/or a government regulation, the need to provide a safety warning indicia such as "OBJECTS IN MIRROR ARE CLOSER THAN THEY APPEAR" in the plano element and/or in the multiradius element can be obviated. Preferably, the plano element comprises a reflector surface area of a size sufficient, when mounted as part of a plano-multiradius reflective element assembly in a driver-side exterior sideview mirror assembly on an automobile, to provide the driver of the automobile a view of a level road surface extending to the horizon from a line, perpendicular to a longitudinal plane tangent to the driver's side of the automobile at the widest point, extending 8 feet out from the tangent plane 35 feet behind the driver's eyes (at a nominal location appropriate for any 95th percentile male driver or at the driver's eye reference points established in Federal Motor Vehicle Standard No. 104), with the driver

seated in the driver's seat and with the driver's seat in the rearmost position. Also, preferably, the aspect ratio of the plano-multiradius reflective element assembly (defined as the ratio of its largest vertical dimension to its largest horizontal dimension, measured with the plano-multiradius reflective element assembly oriented as it would be oriented when mounted in an exterior sideview mirror assembly on an automobile, and with "horizontal" being generally parallel with the road surface the automobile travels on and "vertical" being generally perpendicular to the road surface the automobile travels on) is preferably less than 1, more preferably less than 0.8, most preferably less than 0.6. Further, it is preferable that the multiradius element be disposed outboard (relative to the side of the vehicle and with the plano-multiradius reflective element assembly oriented as it would be when mounted in an exterior sideview mirror assembly on an automobile) on the plano-multiradius reflective element assembly so that the multiradius element is positioned to provide an auxiliary, wide-angle view of a "blind-spot" region in an adjacent sidelane while the more inboard-disposed plano element with unit magnification provides the principal sideview image to the driver.

[0067] Also, it is preferable that the principal axis of the rearward field of view of the multiradius element be different from and angled to the principal axis of the rearward field of view of the plano element when both are attached to the backing plate element of the plano-multiradius reflective element assembly and when the plano-multiradius reflective element assembly is mounted and operated in an exterior sideview mirror assembly on an automobile. Preferably, the principal axis of the rearward field of view of the plano element is directed generally parallel to the road that the automobile equipped with the plano-multiradius reflective element assembly is travelling on (i.e. generally parallel to the longitudinal axis of the automobile) so as to provide the driver with a long-distance view of approaching vehicles in the side lane that the plano element views). However, preferably the principal axis of the rearward field of view of the multiradius element of, for example, a door-mounted driver-side (or passenger-side) exterior sideview mirror assembly in which the plano-multiradius reflective element assembly is mounted is directed generally downwardly towards the road surface adjacent to the driver seating location and/or several feet (such as about 1 foot to about 24 feet; more preferably, about 1 foot to about 12 feet; most preferably about 1 foot to about 8 feet in distance) to its rear (in order to capture a field of view of a rear approaching vehicle that is approaching to overtake, or is about to

overtake, or is overtaking the automobile equipped with the plano-multiradius reflective element assembly). Thus, preferably, the principal axis of the rearward field of view of the multiradius element is angled and directed generally downwardly with respect to the longitudinal axis of the automobile and thus is at an angle to the principal axis of the rearward field of view of the plano element. For example, multiradius element 155' when attached to surface 173" of backing plate 160' (see FIG. 14B) would have its principal axis of rearward view as indicated by 180' as in FIG. 14B, and as such would be canted towards the road surface when mounted in an exterior sideview mirror assembly attached to the side of an automobile. By contrast, plano element 150' when attached to surface 174' of backing plate 160' (see FIG. 14A) would have a principal axis as indicated by 185' as in FIG. 14A and, as such, would be generally parallel to the road surface when mounted in an exterior sideview mirror assembly attached to the side of an automobile. Having the multiradius element canted somewhat downwards towards the road surface assists visual detection by the driver of overtaking vehicles in the traditional "blind-spot" in the adjacent side lane. The angle that the multiradius element is angled on the backing plate element of the plano-multiradius reflective element assembly relative to the plane of the plano reflective element will vary from automobile model to model, but generally is preferred to be in the about 1 degree to about 10 degrees range; about 2 degrees to about 8 degrees range more preferred; and about 3 degrees to about 6 degrees range most preferred. In order to conveniently achieve an angling of the multiradius portion with respect to the plano portion (and preferably a downward angling), the portion of the backing plate element that the multiradius reflective element is attached to can be angled relative to the adjacent portion of the backing plate element that the plano reflective portion is attached to. Thus, and referring to FIG. 14, plano-multiradius reflective element assembly 130' includes a molded polymeric backing plate element 160' comprising a generally flat portion 162' (between BB and CC in FIG. 14) and an adjacent curved portion 161' (between AA and BB). As indicated by 190' and 195', portion AA to BB of backing plate element 160' is generally angled to portion BB to CC of backing plate 160'. Preferably, the portion of backing plate element 160' to which the auxiliary reflective element attaches is angled towards the front (compared to the angling of plano reflective element) of an automobile equipped with the plano-auxiliary reflective element assembly of the present invention. FIG. 14 is a view of plano-multiradius reflective element assembly 130' as it would appear

from above the vehicle as it would be orientated in use (with portion 162' closer to the driver than portion 161'). The wall section, section XX in FIG. 14, taken through section 162' of backing plate element 160' is of substantially constant dimension (as illustrated in FIG. 14A) whereas the wall section, section YY in FIG. 14B, taken through section 161' of backing plate element 160' is of varying dimension and is angled. Plano reflective element 150' and multiradius reflective element 155' (for example, plano element 150' can comprise an electrochromic mirror element and multiradius element 155' can comprise a chrome coated glass reflector) are attached to portions 162' and 161', respectively. By being supported on the angled face 173" (see FIG. 14B) of portion 161', the principal viewing axis of multiradius reflector element 155' is angled downwards towards the road surface, as compared to the more horizontal-viewing principal viewing axis of plano element 150', when plano-multiradius reflective element 130' is mounted in an exterior sideview mirror assembly on an automobile. Demarcation element 165' is preferably molded in the same molding tool as is used to mold backing plate element 160', and so demarcation element 165' is formed as an integral part of backing plate element 160', forming a wall thereof that partitions the surface of backing plate element 160' into a region for receiving the plano reflective element 150' and a region for receiving the auxiliary reflective element 155'. Also, end-caps 170' and 171' are optionally provided. Plano reflective element 150' can attach into the cavity formed between demarcation element 165' and end-cap 171'; multiradius reflective element 155' can attach into the cavity formed between demarcation element 165' and end-cap 170'. Note that the portion of the backing plate element where the wide-angle optic multiradius element attaches can have a thicker wall thickness than that of the portion of the backing plate element where the unit magnification optic element attaches in order to allow for the angling of the multiradius element downwardly relative to the angle of the plano element, as illustrated in FIGS. 14A-B. As illustrated in FIGS. 14A-B, the angle downwards to the longitudinal axis of the vehicle of the multiradius element can generally be set by an angling of a surface of the backing plate element in order to ensure that the principal axis of the rearward field of view of the plano element is directed generally parallel to the longitudinal axis of an automobile equipped with the plano-multiradius reflective element assembly and that the principal axis of the rearward field of view of the multiradius element is directed generally at an angle downwards to the longitudinal axis of the automobile.

[0068] Note that the provision of the plano-multiradius reflective element assembly of this invention as a unitary module has manufacturing advantages, particularly for exterior sideview mirror assembly manufacturers who can procure a plano-multiradius reflective element assembly module from a mirror reflector supplier and then mount the plano-multiradius reflective element assembly module onto an actuator.

[0069] Referring to FIG. 15, a third embodiment 230 of a plano-multiradius reflective element assembly is illustrated. Plano-multiradius reflective element assembly 230 includes a plano reflective element 250 and a separate multiradius reflective element assembly 255, both individually attached to a backing plate element, and with demarcation element 265 disposed at their joint. Plano-multiradius reflective element assembly 230 is about 8.5 inches wide and about 4.25 inches tall (aspect ratio of 0.5), at their largest dimension. Shown as the shaded triangle 240 in plano reflective element 250 is the image of a triangular target object set about 35 feet rearward and of width about 8 feet and of height of about 4.1 feet as would be seen were plano-multiradius reflective element assembly 230 mounted in a driver-side exterior sideview mirror assembly in an automobile such as a sports utility vehicle. In general, it is desirable that the plano reflective element be dimensioned and configured so as to have its rearward field of view capture an image (that is visible, by reflection in the plano reflective element, to a driver seated in the driver's seat in an automobile to which is attached an exterior sideview mirror assembly equipped with the plano-auxiliary reflective element assembly according to this present invention) of a triangular shaped target located about 35 feet rearward of the driver seating location, extending about 8 feet out from the plane defined by the side of the automobile and reaching a height of between about 4 feet and about 5 feet from the road surface at that location 35 feet rearward of the automobile. The total field of view rearwardly of the vehicle of plano-multiradius reflective element assembly 230 (which is a combination of the field of view of plano reflective element 250 and of the auxiliary multiradius reflective element 255) preferably generally subtends an angle of at least about 30 degrees (and more preferably, generally subtends an angle of at least about 35 degrees and most preferably, generally subtends an angle of at least about 40 degrees) with respect to the side of an automobile to which is attached an exterior sideview mirror assembly equipped with plano-multiradius reflective element assembly 230.

[0070] Referring to FIG. 16, another embodiment 310 of the plano-auxiliary reflective element assembly of the present invention is illustrated. Plano-auxiliary reflective element assembly 310 includes a first reflective element 312 and a second or auxiliary, separate reflective element 314 which are together supported in a frame element assembly 316. As will be more fully described below, frame element assembly 316 is adapted such that when reflective elements 312 and 314 are placed, or otherwise positioned, in frame element assembly 316, the angular orientation of each reflective element is pre-established such that during assembly, the assembler need simply place the reflective elements in frame element assembly 316.

[0071] In the illustrated embodiment, frame element assembly 316 includes a frame 318 with a forward facing open portion 318a (FIG. 17) (and thus when frame element assembly 316 is mounted in a vehicle-mounted exterior sideview mirror assembly, the forward facing open portion (318a) is facing to the front of the vehicle) through which a reflective element subassembly 317a, which includes reflective element 312, is positioned in frame element assembly 316 and a rearward facing open portion 318b (FIG. 16) (which faces the rear of the vehicle when frame element assembly 316 is mounted in a vehicle mounted exterior sideview mirror assembly) in which a second reflective element subassembly 317b, which includes reflective element 314, is positioned in frame element assembly 316. Frame 318 preferably comprises a molded member formed from a plastic material, such as a reinforced nylon.

[0072] In preferred form, first reflective element 312 comprises a plano reflective element 350, such as a flat reflector coated glass substrate, with a reflective surface through which the angular height and width of an image of an object is equal to the angular height and width of the object when viewed to the same distance (except for flaws that do not exceed normal manufacturing tolerances) so as to have a unit magnification. Similar to the previous embodiment, plano reflective element 350 may comprise a conventional fixed reflectance reflective element or may comprise a variable reflectance reflective element whose reflectivity is electrically adjustable, as is known in the art. For example, plano reflective element 350 may comprise a flat glass substrate coated with metallic reflector coating, such as a chromium coating, titanium coating, rhodium coating, metal alloy coating, nickel alloy coating, silver coating, aluminum coating, or any alloy or composition

of these metal reflectors. For further details of plano reflective element 350, reference is made to the previous embodiments.

[0073] In the illustrated embodiment, reflective element 312 comprises an electrochromic reflective element and includes a first substrate 312a and a second substrate 312b with an electrochromic medium 312c disposed between first and second substrates 312a, 312b. Such suitable electrochromic media include, for example, a solid polymer matrix electrochromic medium as noted in reference to the previous embodiments. Electrical connectors 320a and 320b are coupled to the electrochromic medium 312c to provide a potential across the electrochromic medium which induces the electrochromic medium to darken, as is known in the art. In the illustrated embodiment, reflective element subassembly 317a also includes an optional heater pad 322, which is disposed behind reflective element 312, and a vibration reducing element, such as a foam pad 326, positioned behind heater pad 322, which absorbs vibration of reflective element 312.

[0074] Referring again to FIG. 17, frame 318 is adapted to receive and support reflective element subassembly 317a, which is mounted to frame 318 by a backing plate 324, such as a plastic backing plate. In the illustrated embodiment, backing plate 324 mounts to the inner perimeter portion of frame 318 using conventional techniques, such as by adhesive bonding, heatstaking, snap-fit coupling, welding, or the like, to form part of frame element assembly 316. Alternatively, backing plate 324 may mount onto foam pad 326, for example, by an adhesive attachment, such as double sided sticky tape. In which case, reflective element 312 may be mounted to an inner surface of frame 318, such as by an adhesive attachment, including for example a silicone adhesive, with heater pad 322 mounted to reflective element 312, such as by an adhesive attachment, and foam pad 326 mounted to heater pad 322, such as by an adhesive attachment including, for example, double-sided sticky tape.

[0075] Frame element assembly 316 mounts reflective element assembly 310 in the mirror casing and preferably on an actuator, such as an electric actuator, which permits adjustment to the orientation of reflective element assembly 310 about one or more axis. Examples of suitable actuators are described in U.S. Pat. Nos. 5,900,999; 5,986,364; 6,132,052; 6,037,689; and 6,094,027 and applications Ser. No. 09/277,632, filed Mar. 26, 1999, now U.S. Pat. No. 6,229,226, and Ser. No. 09/408,867, filed Sep. 29, 1999, now U.S. Pat. No. 6,243,218, which are incorporated by reference in their entireties in U.S. Pat.

No. 6,717,712 (incorporated herein above). Optionally and preferably, backing plate 324 is adapted to engage or be engaged by the actuator for repositioning of plano-auxiliary reflective element assembly 310 about one or more axes. In this manner, the orientation of both reflective element 312 and reflective element 314 are simultaneously adjusted by the actuator. As best seen in FIG. 17, forward facing side 324a of backing plate 324 includes mounting structures 324b which are engaged by the actuator to thereby mount reflective element assembly 310 in the mirror casing.

[0076] Referring again to FIG. 16, frame 318 is a unitary frame and includes a first bezel portion 330 which extends around reflective element 312 and a second bezel portion 332 which extends around reflective element 314 to provide styling utility as well as functional utility. In this manner, a portion of forward facing side of frame 318 forms a support surface for reflective element 312, while a portion of rearward facing side of frame 318 forms first bezel portion 330. Similarly, another portion of the rearward facing side of frame provides support for reflective element 314 and also provides bezel portion 332. In addition, a portion of frame 318 forms a demarcation element at the juncture of reflective elements 312 and 314. In the illustrated embodiment, the demarcation element is formed by a section or portion of bezel portion 330, which will be described in greater detail in reference to bezel portion 330. Thus, frame element assembly 316 provides a support function, a positioning function, including an angling function, while also serving to provide styling utility and a demarcation function.

[0077] Second reflective element 314 comprises a radiused reflective element and, more preferably, a multiradiused reflective element 355 having a multiradiused curvature. For example, the radii of curvature of reflective element 314 may range from about 4000 mm to about 100 mm and, preferably, range from about 3000 mm to about 150 mm, and, most preferably, range from about 2000 mm to about 200 mm. In addition, reflective element 314 may comprise a fixed reflectance reflective element or may comprise a variable reflectance reflective element whose reflectivity is electrically adjustable. Preferably, reflective elements 312 and 314 include glass substrates, with at least the outer surface of each reflective element comprising glass. However, metalized plastic reflectors may also be used which is especially suitable for reflective element 314. In which case, the reflective element (314) would be especially suitable for molding in or along with frame 318, with the preformed metalized substrate forming reflective element 314 being placed

into the mold forming frame 318. For further details of other suitable reflective elements, reference is made to the previous embodiments. In addition to reflective element 314, reflective element subassembly 317b includes a vibration reducing element, such as a foam pad 314a, which is positioned behind reflective element 314. Similar to reflective element 312, foam pad 314a is attached to reflective element 314 by an adhesive attachment, such as a double-sided sticky tape and, similarly, is attached to frame 318 as will be more fully described below.

[0078] As noted above, frame 318 includes a first bezel portion 330 and a second bezel portion 332. In addition, frame 318 includes an auxiliary support element 320 that provides a mounting surface or support surface for reflective element subassembly 317b. As best seen in FIGS. 17 and 18, support element 320 includes a recessed support surface 328 which is angled to provide an angled support surface for reflective element subassembly 317b. Thus, when reflective subassembly 317b is positioned on and mounted on support surface 328, such as by an adhesive attachment between foam pad 314a and support surface 328, the orientation of reflective element 314 is established by the angle of the support surface. Optionally, support element 320 includes gussets 321a and 321b which project forwardly from the forward facing side of frame 318 to thereby reinforce support surface 328.

[0079] Referring to FIG. 16, first bezel portion 330 includes an upper portion 330a, two side portions 330b and 330c, and a lower portion 330d. Side portion 330b forms an acute angle with respect to the lower portion 330d and an obtuse angle with respect to upper portion 330a and together with upper portion 330a, side portion 330c, and lower portion 330d form a perimeter around reflective element 312 to thereby form a styling feature. Second bezel portion 332 extends outwardly from upper portion 330a and downwardly to lower portion 330d of first perimeter portion 330 and together with side portion 330b forms a perimeter around second reflective element 314. Support element 320 extends behind and between side portion 330b and second bezel portion 332 so that reflective element 314 is recessed behind side portion 330b and bezel portion 332.

[0080] As best seen in FIG. 18, upper portion 330a, side portions 330b and 330c, and lower portion 330d are substantially coplanar and together define an outer surface below which reflective element 312 is recessed when reflective element 312 is mounted in frame 318. In contrast, perimeter portion 332 is angled forwardly with respect to the plane in

which upper portion 330a, side portions 330b and 330c, and lower portion 330d lie. It should be understood that the terms "forwardly", "rearwardly" and "downwardly", are used in reference to when the mirror system is mounted in an automobile. Therefore, "forwardly" is a direction heading toward the front of the automobile, "rearwardly" is a direction heading to the rear of the automobile, "outwardly" is a direction away from the side of the vehicle on which the mirror assembly is mounted, and "downwardly" is a direction heading toward the surface on which the vehicle is positioned (such as a ground or road surface). Similarly as noted above, reflective element 314 is recessed below an outer surface of perimeter portion 332 and also below the outer surface of side portion 330b when mounted in frame 318.

[0081] As would be understood from FIGS. 17-19, support surface 328 is also angled forwardly with respect to back plate 324 and/or reflective element 312 when frame element assembly 316 is mounted in an automobile mounted exterior sideview mirror system. In addition, support surface 328 is also angled or tilted downwardly with respect to reflective element 312 and/or backing plate 324 such that when reflective element 314 is supported on support surface 328, reflective element 314 provides an increased field of view extending laterally or outwardly from the longitudinal axis of the automobile and also downwardly of the longitudinal axis of the automobile.

[0082] Referring to FIGS. 21 and 22, support surface 328 is configured such that reflective element 314 is tilted forwardly at an angle α with respect to the X-axis of reflective element 312. In one form, angle α is in a range of about 0.75 degrees to about 5 degrees. In another form, angle α is in a range of about 1 degree to about 3 degrees. In yet another form, angle α is in a range of about 1.25 degrees to about 2.5 degrees. Reflective element 314 is also tilted downwardly with respect to the Y-axis of reflective element 312 at an angle β . In one form, angle β is in a range of about 0.75 degrees to about 5 degrees. In another form, angle β is in a range of about 1.5 degrees to about 3.5. In yet another form, angle β is in a range of about 2 degrees to about 3 degrees. With the tilted orientation of reflective element 314, reflective element 314 provides a field of view with a principal axis that sweeps outwardly and downwardly with respect to the principal axis of the field of view of reflective element 312.

[0083] In the illustrated embodiment, support surface 328 is provided by a plate member 321. Plate member 321 may comprise a solid plate member or a foraminous plate member. In the illustrated embodiment, plate member 321 is integrally formed with perimeter portions 330 and 332 during the molding process of frame 318. As previously noted, frame 318 includes a rearwardly facing opening 318b through which reflective element 314 is inserted for placement on support surface 328. For example, reflective element 314 may be positioned in frame 318 on support surface 328 during the molding process of frame 318, such as by insert molding, or may be inserted into frame 318 before the plastic material forming frame 318 is fully cured and is still pliable. In which case, reflective element subassembly 317b is mounted to auxiliary support 320 by an adhesive attachment or a mechanical attachment. Alternatively, support surface 328 may be formed by peripheral flange or a frame. In this manner, reflective element subassembly 317b may be placed in frame 318 from its forward facing side.

[0084] Referring to FIG. 22, when reflective element assembly 310 is mounted in a vehicle reflective element 312 has a field of view 360 which forms an angle A with respect to the longitudinal center line of the vehicle in a range of about 8 degrees to about 20 degrees. In another form, angle A is in a range of about 10 degrees to about 18 degrees. In yet another form, angle A is in a range of about 12 degrees to about 16 degrees. Similarly, reflective element 314 has a field of view 362 which forms an angle C in range of about 15 degrees to about 50 degrees. In another form, angle C is in a range of about 15 degrees to about 35 degrees. In yet another form, angle C is in a range of about 15 degrees to about 25 degrees. Consequently, the overall field of view of reflective elements 312 and 314 extends over an angle B, which ranges from about 8 degrees to about 50 degrees in one form, about 10 degrees to about 35 degrees in another form, and about 12 degrees to about 25 degrees in yet another form. Furthermore, field of views 360 and 362 overlap over a range having angle D in a range of about 20 degrees to about 2 degrees, or in a range of about 15 degrees to about 5 degrees. In another form, angle D is in a range of about 10 degrees to about 8 degrees.

[0085] From the foregoing, it can be appreciated that reflective elements 312 and 314 provide a wider field of view than a wholly planar rearview mirror element that fully accommodates an equivalent frame having similar dimensions. In addition, because reflective elements 312 and 314 have overlapping field of views, an image in the field of

view of reflective element 314 will transition or move between the reflective elements and appear in both reflective elements during the transition to thereby enable the driver of the automobile to view or be conscious of the object continuously. In the illustrated embodiment, reflective element 314 is positioned in an outboard position relative to reflective element 312; therefore, when a vehicle or object that is approaching the automobile from the rear and to some extent from the side, the image of the approaching object will first appear in reflective element 312, then appear in both reflective elements 314 and 312, and then move to reflective element 314 so that the driver will be initially aware of the approaching object when its image first appears in reflective element 312 and continue to be aware of the object as it moves closer to the automobile, thus increasing the range of viewing of the driver. Since the image transitions smoothly from reflective element 312 to reflective element 314, the driver's awareness of the object is continuous and, further, the driver is not distracted from sudden transitions that often occur with conventional spotter mirrors. Typically, when an object "falls" or "drops" out, a driver's consciousness of the object reduces significantly, if not ceases, which is one of the causes of many automobile blind spot accidents. Hence, when combined with the field of view of an interior rearview mirror system, the present invention reduces, if not eliminates, an automobile's blind spot. For further discussion of blind spots in vehicle rearview mirror systems, reference is made to U.S. provisional application entitled VEHICULAR REARVIEW MIRROR SYSTEM, Ser. No. 60/252,149, filed Nov. 20, 2000 by Robert E. Schnell, David K. Willmore, and Richard J. Weber, which is incorporated by reference in its entirety in U.S. Pat. No. 6,717,712 (incorporated herein above). Thus, the plano-auxiliary reflective element assembly provides a seamless rearvision function whereby the image of a side approaching/side overtaking other vehicle is substantially seamlessly maintained as the image of the overtaking or approaching vehicle transitions from being principally and substantially viewed by the driver of the vehicle (the vehicle mounted with the mirror system of the present invention) in the plano reflective element to be seen in the auxiliary reflective element.

[0086] Referring to FIG. 23, the numeral 410 generally designates yet another embodiment of an automobile exterior sideview mirror system of the present invention. Exterior sideview mirror system 410 includes a housing 412, a first reflective element 414, and a second or auxiliary, separate reflective element 416, which together provide an increase

field of view over conventional planar reflectors mounted in a frame of equivalent dimensions to the combined lateral dimensions of reflective element 414 and 416.

[0087] Housing 412 includes a mirror casing 417 and a sail 418, which mounts casing 412 to a side of an automobile. Though illustrated as a fixed mounting arrangement, it should be understood that mirror system 410, like the previous embodiments, may comprise a break-away mirror system or a powerfold mirror system.

[0088] In the illustrated embodiment, reflective element 414 comprises a plano reflective element having a unit magnification, similar to the plano reflective elements described in reference to the previous embodiments. Reflective element 416 preferably comprises a wide-angle reflector, such as a convex or aspheric reflector, and may include a multiradiused curvature. For further description of suitable reflectors, reference is made to the previous embodiment.

[0089] In the illustrated embodiment, reflective element 416 is mounted in an outboard position relative to reflective element 414 and is fixedly mounted to bezel 420 of mirror casing 417. In addition, reflective element 416 is preferably angled downwardly and forwardly relative to first reflective element 414 when mirror system 410 is mounted to an automobile to thereby increase the field of view of mirror system 410. Optionally and preferably, reflective element 416 is detachably mounted to bezel 420, such as by mechanical fasteners, including clips, so that reflective element 416 can be removed, such as for replacement.

[0090] Reflective element 414 preferably comprises an independently positionable reflective element and is mounted by a backing member, such as a backing plate, to an actuator, which provides multi-axis positioning of reflective element 414. In this manner, reflective element 414 and reflective element 416 are separately and independently mounted in housing 412. In addition, reflective element 414 optionally extends behind reflective element 416 in order to maintain the overlap of the field of views of reflective elements 414 and 416 even when reflective element 414 is moved by the actuator. Similar to the previous embodiment, when an object moves toward the automobile, in which mirror system 410 is mounted, from the rear of the automobile or laterally with respect to the automobile, the image of the object will appear initially in reflective element 414. As the object moves closer to the automobile, the image of the object will move from reflective element 414 to reflective element 416 such that when the image transitions between

reflective element 414 and reflective element 416, the image will appear in both reflective elements.

[0091] Also, although it is preferable to utilize a multiradius or compound curvature reflective element, such as an aspherical element or a compound curvature element, for the second or auxiliary mirror element adjacent the plano or first reflective element (as this enables least discontinuity in image at the joint between the adjacent elements of the assembly), a spherical reflective element (that has substantially only one radius of curvature and, as such, is a section from a sphere) can optionally be used adjacent the plano reflective element instead of, or in addition to, the multiradius reflective element. Also, a plano auxiliary mirror such as a flat mirrored substrate can be used, less preferably, as a substitute for a multiradius reflective element in those embodiments where the auxiliary reflective element is angled relative to the plane of the principal, plano reflective element so as to view a blind spot region of the principal plano element. Also, the plano-multiradius reflective element assembly can optionally be fixedly attached to an exterior sideview mirror assembly housing that is not movable, or, alternately, the exterior sideview mirror assembly housing to which the plano-multiradius reflective element assembly is fixedly attached can itself be actuated to move, such as by motor action, so that by moving the exterior sideview mirror assembly housing, the field of rearward view of the plano-multiradius reflective element assembly fixedly attached thereto can correspondingly move and be repositioned to suit the field of view need of a particular driver seated in the automobile cabin.

[0092] The substrate 18 of the reflective element 12 of the present invention may be formed (such as by casting, extrusion or injection molding) of a polymeric optical resin material, such as an acrylic or polycarbonate resin, a polyolefin, a cyclic olefin copolymer, such as a COC resin known as "TOPAS" and available from Ticona of Summit, NJ (such as a resin of the type described in U.S. pat. application, Ser. No. 09/946,228, filed Sep. 5, 2001 for IMPROVED PLASTIC SUBSTRATE FOR INFORMATION DEVICE AND METHOD FOR MAKING SAME, which is hereby incorporated herein by reference) or the like. Because the substrate can be, for example, injection molded from an optical resin, the substrate may be molded or formed to a desired shape having a wide angle or multi-radius surface, which is typically challenging to accomplish with glass sheets. This is because any prescription or form for the substrate can be established in an injection mold

by machining, such that when the injection mold is filled with molten injected optical resin material, the optical resin material takes the shape of the mold. Thus, for example, a substrate having a substantially or fully flat inboard region for a multi-radius (often referred to as an aspheric) exterior mirror element is fully practical.

[0093] As shown in FIGS. 1-3, inboard portion or surface 18c of exterior surface 18b is positioned at or toward the side of the reflective element that is toward the side body of the vehicle when the mirror assembly is mounted to or attached to the vehicle. The inboard portion 18c of surface 18b of substrate 18 may comprise a substantially flat or slightly curved or less curved surface, such as a surface having a radius of curvature of preferably greater than at least approximately 4000 mm, more preferably greater than at least approximately 9000 mm, and most preferably greater than at least approximately 12000 mm. The inboard surface 18c may provide a field of view of up to approximately 10 degrees, preferably up to approximately 15 degrees, and more preferably up to approximately 20 degrees.

[0094] Outboard portion or surface 18d of exterior surface 18b of substrate 18 is positioned outward from inboard portion and is thus further away from the side body of the vehicle when the mirror assembly is mounted to or attached to the vehicle. Outboard portion 18d of exterior surface 18b may be a more convex or curved surface, such that the substrate comprises a wide angle or multi-radius exterior surface substrate. The more curved outboard surface 18d of the substrate may have radii of curvature in the range of less than about 4000 mm to about 100 mm or lower. The more curved outboard portion or surface 18d may provide an extended field of view when combined with the less curved inboard portion or surface 18c. For example, the combined field of view of the mirror reflective element 12 may be preferably greater than at least approximately 25 degrees, more preferably greater than at least approximately 35 degrees, and most preferably greater than at least approximately 45 degrees. The substrate may be formed to have curves or shapes or to provide other field of views, without affecting the scope of the present invention.

[0095] The exterior surface 18b of substrate 18 may be coated or covered with a substantially transparent functional film or layer 20, such as an anti-abrasion film or layer, such as an ultrathin glass film or layer or sheet having a thickness of preferably less than or equal to approximately 0.8 mm, more preferably less than or equal to approximately 0.5

mm, and most preferably less than or equal to approximately 0.3 mm. The ultrathin glass film or layer or sheet 20 provides a flexible glass film which can be conformed to the exterior surface of the molded substrate (for example, such as described in U.S. Pat. No. 5,085,907, which is hereby incorporated herein by reference) after the substrate is molded. The ultrathin glass film or layer may provide substantial protection against scratches on the outboard surface, such as may occur due to impact by debris at the outside of the vehicle (for exterior mirror assembly applications) or by use of ice scrapers and the like on the glass surface and the like. The ultrathin glass film or layer may be applied to a molded or extruded strip (such as described below with respect to FIGS. 5-8) or may be applied to the surface or surfaces of a formed or cut substrate, without affecting the scope of the present invention. The flexible ultrathin glass film or layer of the present invention allows the wide angle or multi-radius substrate to be molded in the desired shape out of a transparent acrylic resin material, yet may conform to the curved or multi-radius or aspheric shape and provide enhanced protection or scratch resistance to the substrate.

[0096] It is envisioned that other functional films or hard coats or anti-abrasion films or the like may be applied to the exterior surface of the molded substrate, such as via adhering or applying a film to the exterior surface or via dip coating or vacuum deposition or the like. Optionally, a hydrophobic film or hydrophilic film or element or property may also or otherwise be applied to the exterior surface 18b of the substrate. Optionally, the functional film may comprise a non-glass or polymeric film, such as a polymeric material that is a harder and/or different property material than the substrate itself. Optionally, the anti-abrasion film may be formed of the same resin material as the substrate to match the coefficients of thermal expansion and thus reduce thermal expansion/contraction mismatches between the materials.

[0097] Optionally, the inner or rear surface 18a of the substrate 18 may have a reflective layer or coating or film or sheet 22 laminated or otherwise applied thereto. For example, the reflective layer or film 22 may comprise a polymeric reflective film 22 laminated or otherwise adhered or applied to the rear or inner surface 18a of a molded or extruded or cast strip (such as described below with respect to FIGS. 5-8) or of the molded or formed substrate 18. Reflective film 22 may comprise a polymeric reflective film, such as an all polymer-thin-film multilayer, high reflective mirror film, such as a multilayer, non-metallic reflective film which may comprise multiple coextrusion of many plastic layers to form a

highly reflective mirror film, such as described in U.S. Pat. Nos. 3,773,882; 3,884,606; and 3,759,647, which are hereby incorporated herein by reference. Such a reflective film thus may comprise multilayers of polymer materials to form a highly reflective mirror film, such as a Radiant Light Film, a Radiant Mirror Film or a Radiant Color Film, such as commercially available from 3M of St. Paul, Minn., such as a Radiant Color Film CM590 or CM500. Also, a durable metallized polymeric mirror layer can be used, such as described in U.S. Pat. No. 5,361,172, which is hereby incorporated herein by reference.

[0098] As shown in FIG. 4, it is envisioned that a substrate or substrate shape or sheet or strip of substrate material 118 may have a reflective film or layer 122 adhered or laminated or otherwise applied to the exterior surface 118b of the substrate material. An anti-abrasion film or layer 120 (which may comprise an ultrathin glass film or layer as described above) may be adhered or laminated or otherwise applied to the reflective film or layer 122. In such an application, with the reflective layer on the front or exterior surface of the substrate, the substrate material may be molded or formed of a polymeric material that does not provide optical clarity and need not be transparent. The substrate material may act only as a support or backing plate for the reflective film or layer and the anti-abrasion film or layer and thus may be opaque or non-transparent. The exterior surface 118b of substrate material 118 may comprise a wide angle exterior surface or a multi-radius exterior surface having a less curved inboard portion or surface 118c and a more curved outboard portion or surface 118d, such as discussed above with respect to substrate 18.

[0099] Optionally, and such as shown in FIGS. 5, 6 and 8, the optical resin material may be molded or extruded or cast into a generally continuous strip 19 having the desired curved or multi-radius surfaces, and may be cut to form the substrates. The substrates may be cut from the strip via any known cutting process, such as via a laser cutting process or a water-jet cutting process or the like, without affecting the scope of the present invention.

[00100] As shown in FIGS. 5-8, the molding processes and film or layer application processes of the present invention may be used to form a prismatic or wedge-shaped strip for forming prismatic or wedge-shaped substrates 18' (FIG. 7) for use in an interior rearview mirror assembly of a vehicle.

[00101] As also shown in FIGS. 5-8, the substrate material or optical resin material may be extruded or cast to form the continuous strip or sheet 19. For example, and as shown in FIGS. 5 and 5A, the strip 19 may be extruded by an extruder 24, which, preferably

continuously, extrudes the optical resin material through an extrusion nozzle 26. The extruded material may be moved through an annealing Lehr 28 to reduce or substantially eliminate birefringence, striation, stress and/or distortion in the strip or substrates. The coatings or layers or films 20 and/or 22 may be applied to one or both surfaces of the strip or substrate after the annealing process. The strip 19 may then be cut, such as via laser cutting or water-jet cutting devices or processes 30, or via other forming processes, to form the substrates 18' after the films or coatings have been applied thereto.

[00102] Optionally, and as shown in FIG. 8, the strip 19 of optical polymeric resin material may be cast by a caster 32, which deposits the molten polymer or resin material onto a float section 34, such as a heated plate or heated melt. The float section 34 may be angled to form the wedge-shaped strip as the strip or ribbon of cast molten polymer solidifies as it passes across the hot float section (it is also envisioned that the float may provide a curved surface to form the curved outboard surface of the substrate). The coatings or layers or films 20, 22 may be applied to the solidified strip and the strip may be cut to form the substrates after the coatings or layers or films have been applied thereto.

[00103] Because the films or layers are flexible, it is envisioned that the anti-abrasion film or ultrathin glass film and/or the reflective polymeric film may be unwound or unrolled and applied along the generally continuously extruded or cast substrate material or strip 19. For example, and as shown in FIGS. 5-8, the ultrathin glass film (or other outer layer anti-abrasion coating or film) 20 may be provided in a reel or roll form or strip 20a and may be unwound or unrolled and laminated or otherwise adhered or applied along the exterior surface 19b of the extruded or cast strip 19 of substrate material. Likewise, the reflective polymeric film 22 may be provided in a reel or roll form or strip 22a and may be attached or applied to the inner surface 19a of the substrate material strip 19, such as via laminating or adhering or otherwise applying the film to the substrate material, such as by using optical adhesive and/or via rolling or ironing the film or sheet (preferably at an elevated temperature and with vacuum assist) onto the substrate or strip surface, to secure the reflective film to the substrate or extruded or cast strip or sheet.

[00104] Optionally, the glass film or layer or sheet (or reel or roll of glass sheet or strip) may be coated with a highly reflective metallic layer, such as silver or aluminum or the like, deposited on or applied to its inner surface (i.e., the surface which is adhered to or otherwise applied to the substrate or substrate sheet or strip). The reflective layer or

coating may be applied to the glass film or layer with or without transparent overcoats. The glass film thus may provide the reflective layer at the exterior surface of the substrate, such that the reflective layer provides the second layer or surface, with the substrate behind the reflective layer. The glass sheet or film may thus be provided with the reflective mirror coating already applied thereto. The glass layer with reflective layer or coating applied thereto may be provided in a reel or roll form for applying both the reflective layer and the anti-abrasion layer to the exterior surface of the substrate or substrate strip or sheet in one application process. In such an application, the substrate material need not comprise a transparent optical resin material, and a separate reflective layer or film or coating would not be necessary at the inner or rear surface of the substrate.

[00105] It is envisioned that other hard coats or films or the like may be applied to one or more surfaces of the molded substrate strip or to the molded and cut substrates, such as via dip coating or vacuum deposition or the like, without affecting the scope of the present invention. The other hard coats or films may be substantially flexible and may be applied via unrolling of a reel of an anti-abrasion film or sheet and applying the film or sheet to a surface of an extruded or cast strip of transparent acrylic resin or the like, as discussed above. Optionally, a hydrophobic film or hydrophilic film or element or property may also or otherwise be applied to (or sprayed on) one or both surfaces 18a, 18b of the substrate or strip or sheet. Optionally, one or both of the reflective polymeric film 22 and the anti-abrasion film 20 may be formed of the same resin material as the substrate 18, 18' or substrate strip 19 to match the coefficients of thermal expansion and thus reduce thermal expansion/contraction mismatches between the materials.

[00106] Optionally, and as described in U.S. Pat. No. 5,724,187, incorporated above, a mirror reflective element assembly 401 may include front and rear substrates that may be flush or offset relative to one another. For example, and with reference to FIGS. 24 and 25A-C, an exposed portion of the conductive electrode coatings 404, 404' may be provided through displacement in opposite directions relative to one another - i.e., laterally from, but parallel to, the cavity which is created by the substrates 402, 403 and the sealing means 405 of the substrates 402, 403 onto which the bus bars may be affixed or adhered. (See FIG. 25A.) In addition, substrates 402, 403 may be off-set to provide an exposed portion of the conductive electrode coatings 404, 404' through displacement in opposite directions relative to one another followed by perpendicular displacement relative to one another.

(See FIG. 25B.) The dimensions of substrates 402, 403 may also be such that, for example, substrate 402 may have a greater width and/or length than substrate 403. Thus, simply by positioning substrates 402, 403 in spaced-apart relationship and so that their central portions are aligned will allow for peripheral edges of the substrate with greater dimensions to extend beyond the peripheral edges of the substrate with smaller dimensions. Thus, a portion of conductive electrode coating 404 or 404' will be exposed, depending on whichever of substrates 402, 403 is dimensioned with a larger width and/or length. (See FIG. 25C.)

[00107] An exposed portion of the conductive electrode coatings 404, 404' may also be provided in a flush design, where the substrates 402, 403 are sized and shaped to like dimensions. In such a flush design, the first substrate 402 and the second substrate 403 may each be notched at appropriate positions along their respective edges. The notches so provided present convenient areas for bus bars and/or point contacts to which are connected or affixed electrical leads 410 for the introduction of an applied potential thereto.

[00108] It may also be desirable to apply a layer of reflective material onto the inward surface of substrate 403, and with substrate 403 notched in at least one appropriate position along its edges. In this way, direct access is available to the conductive electrode coated inward surface of substrate 402. Likewise, substrate 402 may be notched at a position appropriately spaced from the notch or notches on substrate 403 to provide access to the conductive electrode coated inward surface of substrate 403. These notches provide convenient areas for electrical leads to be connected or affixed, and allow for such connection or affixation to be made within the overall dimensions of the mirror assembly. For example, one or both of the substrates 402, 403 may be notched along one or more edges, and bus bars may then be affixed over the exposed portion of conductive electrode coatings 404, 404' of substrates 402, 403. Electrical leads may then be joined to the bus bars. The electrical connection may be made to the inward surfaces of substrates 402, 403 without requiring further electrical connection on the peripheral edge of the mirror assembly. As such, the electrical connection to conductive electrode coatings 404, 404' will be hidden from view by the reflective element and/or the mirror case or housing.

[00109] Alternatively, one or more localized lobe(s) may be provided at appropriate positions along the respective edges of substrates 402, 403 to facilitate direct access to the conductive coated inward surfaces of substrates 402, 403.

[00110] The bus bars may also comprise thin metal films, preferably with a thickness within the range of about 500 Å to about 50,000 Å or greater. These thin metal film bus bars may be deposited onto conductive electrode 404 and/or 404' by vacuum deposition, such as by evaporation or sputtering, and typically have a width within the range of about 0.05 mm to about 6 mm (and preferably with a thickness in the range of 0.05 μm to about 5 μm or greater) and are inboard from the perimeter edge of the substrate.

[00111] To form the thin metal film bus bars, a mask may be affixed over the central region of the substantially transparent conductive electrode coated substrate leaving at least a portion, and preferably most, of the perimeter region unmasked. Then a thin film of metal, such as chromium and/or silver, or other metals such as copper, titanium, steel, nickel-based alloys, and the like, may be deposited using a vacuum deposition process across the entire surface, coating both the masked central region and the unmasked perimetral region. Thereafter, the mask may be removed leaving the central region of the substrate transparent and with a conducting thin metal film bus bar deposited on at least a portion of the perimetral region. For manufacturing economy, it may be desirable to establish thin metal film bus bars on the inward surface of substrate 402, conductive electrode coating 404' and electrochromic solid film 407 in a unitary vacuum deposition process step. Thus, it may be convenient to overlay in central alignment, for example, substrate 403 (being uncoated glass) onto the substantially transparent conductive electrode coated surface of substrate 402, where substrate 403 is sized and shaped about 2 mm to about 4 mm smaller in both length and width than substrate 402 (see e.g., FIG. 25C). A peripheral edge of substrate 402 of about 2 mm to about 4 mm will then extend beyond the peripheral edge of substrate 403. In this instance, substrate 402 is made, for example, from ITO-coated glass, and substrate 403 is made from clear soda-lime glass. With this configuration, a vacuum deposition process may be used to deposit a thin metal film and, optionally, a metal oxide thereover, across the entire surface.

[00112] Upon completion of the deposition process, the substrates 402, 403 may be separated from one another. The formation of a thin metal film bus bar consisting of a chromium/silver coating about the peripheral edge of substrate 402 may then be seen where, because of its smaller dimensions, substrate 403 has served the role of a mask to the major, central region of substrate 402 during deposition. That is, when substrate 403 is removed, the major, central region of substrate 402 has not been coated during the

deposition and the transparency of the major, central region of substrate 402 is maintained. Because this thin metal film bus bar is highly conductive and extends about the entire periphery of substrate 402, electric potential may be supplied by means of a point electrical contact (optionally with local removal of any metal oxide) without the need for a large metal clip or ribbon connector wire as has been conventionally used heretofore. Moreover, because the thin metal film bus bar consists of a chromium/silver coating it forms a highly reflective perimeter coating which may be used to conceal any seal and/or electrical connection for the electrochromic cell. [See U.S. Pat. No. 5,060,112 (Lynam)]

[00113] Also, whether the sealing means 405 is a single seal or a double seal, it may be desirable for the seal material to comprise a cured conductive adhesive so that the seal, or at least a portion thereof, may provide, in whole or at least in part, an electrical bus bar function around the perimeter of a substrate of the assembly. When using such a combined seal and bus bar, care should be taken to avoid electrically shorting the inward facing surfaces of substrates 402 and 403. To obviate this, a seal construction, such as that shown in FIG. 26A, may be used. With reference to FIG. 26A, substrates 520 and 530 are coated on their inwardly facing surfaces with electrical conductor electrodes 520' and 530'. The substrates 520, 530 are mated together with the compound seal 550. The compound seal 550 includes a conducting seal layer 550A (formed, for example, of a conducting epoxy such as is described below) and a non-conducting, electrically insulating seal layer 550B (formed, for example, of a conventional, non-conducting epoxy), which serves to insulate the two conducting electrodes from electrically shorting via conducting seal layer 550A. Since the compound seal 550 essentially circumscribes the edge perimeter of the part, the conducting seal layer 550A (to which electrical potential may be connected to via the electrical lead 590) serves as an electrically conductive bus bar that distributes applied electrical power more evenly around and across the electrochromic medium (not shown) sandwiched between the substrates 520 and 530.

[00114] Where the electrical conductor electrode 520', 530' on at least one of the opposing surfaces of the substrates 520, 530 is removed (or was never coated) in the region of the peripheral edge (as shown in FIG. 26B), a unitary conducting seal (as opposed to the compound seal of FIG. 26A) may be used. Reference to FIG. 26B shows the electrically conducting seal 550A joining the electrical conductor electrode 530' on the surface of substrate 530 to a bare, uncoated surface of opposing substrate 520. Since the contact

area of the conducting seal layer 550A to the substrate 520 is devoid of the electrical conductor electrode 520', the conducting seal layer 550A does not short the electrodes 520' and 530'. Conducting seal layer 550A serves the dual role of bus bar and seal, yielding economy and ease in device fabrication and production. Conducting seal layer 550A may form a single seal for the cell or may be one of a double seal formed, for example, when a conventional, non-conducting epoxy is used inboard of that conducting seal.

[00115] Such a construction is particularly amenable to devices, such as those depicted in FIG. 24. For instance, in a rearview mirror, a fixture can form a mask around the edge substrate perimeter, while an adhesion layer of chromium followed by a reflector layer of aluminum followed by an electrochromic layer of tungsten oxide are deposited. Once removed from such a coating fixture, the edges, as masked by the coating fixture, are uncoated and present a bare glass surface for joining via a conductive epoxy seal to an opposing transparent conductor coated substrate. In such a configuration, the conductive seal can serve as a bus bar for the transparent conductor coated substrate it contacts without shorting to the reflector/adhesion layers on the opposite substrate.

[00116] As described supra, it may be advantageous to construct electrochromic mirrors whose reflective element is located within the laminate assembly. This may be achieved by coating the inward surface of substrate 403 with a layer of reflective material, such as silver, so that the silver coating (along with any adhesion promoter layers) is protected from the outside environment. For example, a layer of reflective material may be vacuum deposited onto the inward surface of substrate 403 in one and the same process step as the subsequent deposition of the electrochromic solid film 407 onto substrate 403. This construction and process for producing the same not only becomes more economical from a manufacturing standpoint, but also achieves high optical performance since uniformity of reflectance across the entire surface area of the mirror is enhanced. The thin film stack [which comprises the electrochromic solid film 407 (e.g., tungsten oxide), the layer of reflective material (e.g., silver or aluminum) and any undercoat layers between the layer of reflective material and substrate 403] should have a light reflectance within the range of at least about 70 % to greater than about 80 %, with a light transmission within the range of about 1 % to about 20 %. Preferably, the light transmission is within the range of about 3

% to about 20 %, and more preferably within the range of about 4 % to about 8 %,with a light reflectance greater than about 80 %.

[00117] The inward facing surface of substrate 403 may be coated with a multi-layer partially transmitting/substantially reflecting conductor comprising a partially transmitting (preferably, in the range of about 1 % to about 20 %)/substantially reflecting (preferably, greater than about 70 % reflectance, and more preferably, greater than about 80 % reflectance) metal layer (preferably, a silver or aluminum coating) that is overcoated with an at least partially conducting transparent conductor metal oxide layer [comprising a doped or undoped tin oxide layer, a doped or undoped indium oxide layer (such as indium tin oxide) or the like]. Optionally, an undercoating metal oxide (or another at least partially transmitting metal compound layer, such as a metal nitride like titanium nitride) may be included in the stack which comprises the multilayer conductor. This multi-layer conductor functions as the reflective element, and can be overcoated with electrochromic solid film 407 during fabrication of an electrochromic mirror incorporating on demand displays.

[00118] Alternatively, the multi-layer conductor described supra may be used on the inward surface of substrate 403, with the electrochromic solid film 407 coated onto the inward surface of substrate 402.

[00119] A light reflectance of at least 70 % (preferably, at least 80 %) for the reflective element to be used in an electrochromic mirror incorporating on demand displays is desirable so that the bleached (unpowered) reflectivity of the electrochromic mirror can be at least 55 % (preferably, at least 65 %) as measured using SAE J964a, which is the recommended procedure for measuring reflectivity of rearview mirrors for automobiles. Likewise, a transmission through the reflective element of, preferably, between about 1 % to 20 % transmission, but not much more than about 30% transmission (measured using Illuminant A, a photopic detector, and at near 'normal incidence) is desirable so that emitting displays disposed behind the reflective element of the electrochromic mirror are adequately visible when powered, even by day but, when unpowered and not emitting, the displays (along with any other components, circuitry, backing members, case structures, wiring and the like) are not substantially distinguishable or visible to the driver and vehicle occupants.

[00120] Optionally, the outermost surface of the substrate (i.e., the surface contacted by the outdoor elements including rain, dew and the like when, for example, the substrate forms

the outer substrate of an interior or exterior rearview mirror for a motor vehicle constructed) can be adapted to have an anti-wetting property. For example, the outermost glass surface of an exterior electrochromic rearview mirror can be adapted so as to be hydrophobic. This reduces wetting by water droplets and helps to obviate loss in optical clarity in the reflected image off the exterior mirror when driven during rain and the like, caused by beads of water forming on the outermost surface of the exterior electrochromic mirror assembly. Preferably, the outermost glass surface of the electrochromic mirror assembly is modified, treated or coated so that the contact angle θ (which is the angle that the surface of a drop of liquid water makes with the surface of the solid anti-wetting adapted outermost surface of the substrate it contacts) is preferably greater than about 90 degrees, more preferably greater than about 120 degrees and most preferably greater than about 150 degrees. The outermost surface of the substrate may be rendered anti-wetting by a variety of means including ion bombardment with high energy, high atomic weight ions, or application thereto of a layer or coating (that itself exhibits an anti-wetting property) comprising an inorganic or organic matrix incorporating organic moieties that increase the contact angle of water contacted thereon. For example, a urethane coating incorporating silicone moieties (such as described in U.S. Pat. No. 5,073,012) may be used. Also, to enhance durability, diamond-like carbon coatings, such as are deposited by chemical vapor deposition processes, can be used as an anti-wetting means on, for example, electrochromic mirrors, windows and devices.

[00121] Optionally, it is envisioned that such ultrathin glass films, anti-abrasion films, reflective films or reflective systems may be used for electrochromic mirror reflective elements or cells as well. For example, the interior or exterior rearview mirror assembly of the present invention may comprise an electrochromic mirror, such as an electrochromic mirror assembly and electrochromic element utilizing principles disclosed in commonly assigned U.S. Pat. Nos. 5,140,455; 5,151,816; 6,690,268; 6,178,034; 6,154,306; 6,002,544; 5,567,360; 5,525,264; 5,610,756; 5,406,414; 5,253,109; 5,076,673; 5,073,012; 5,117,346; 5,724,187; 5,668,663; 5,910,854; 5,142,407 and/or 4,712,879, which are hereby incorporated herein by reference, and/or as disclosed in the following publications: N. R. Lynam, "Electrochromic Automotive Day/Night Mirrors", SAE Technical Paper Series 870636 (1987); N. R. Lynam, "Smart Windows for Automobiles", SAE Technical Paper Series 900419 (1990); N. R. Lynam and A. Agrawal, "Automotive Applications of

Chromogenic Materials”, Large Area Chromogenics: Materials and Devices for Transmittance Control, C.M. Lampert and C.G. Granquist, EDS., Optical Engineering Press, Wash. (1990), which are hereby incorporated by reference herein. The mirror assembly may comprise an interior rearview mirror assembly, and may include an accessory module or may be mounted to an accessory module, such as an accessory module of the types disclosed in U.S. pat. application, Ser. No. 10/355,454, filed Jan. 31, 2003, now U.S. Pat. No. 6,824,281, which is hereby incorporated herein by reference.

[00122] Optionally, the mirror assembly may include one or more displays for displaying information to a driver of the vehicle at or through the reflective element of the mirror assembly. For example, the mirror assembly may include one or more displays of the types described in U.S. Pat. Nos. 6,329,925; 6,501,387; 6,690,268; 5,910,854; 6,420,036; 5,668,663; and 5,724,187, and/or in U.S. pat. applications, Ser. No. 10/054,633, filed Jan. 22, 2002, now U.S. Pat. No. 7,195,381; and Ser. No. 10/456,599, filed Jun. 6, 2003, now U.S. Pat. No. 7,004,593, and/or in PCT Application No. PCT/US03/29776, filed Sep. 19, 2003; PCT Application No. PCT/US03/35381, filed Nov. 5, 2003; and/or PCT Application No. PCT/US03/40611, filed Dec. 19, 2003, and/or in U.S. provisional applications, Ser. No. 60/508,086, filed Oct. 2, 2003; Ser. No. 60/525,952, filed Nov. 26, 2003; Ser. No. 60/471,546, filed May 19, 2003; Ser. No. 60/525,537, filed Nov. 26, 2003; and Ser. No. 60/556,259, filed Mar. 25, 2004, which are all hereby incorporated herein by reference, without affecting the scope of the present invention.

[00123] Optionally, the mirror assembly may include or be associated with electronic accessories, such as, for example, antennas, including global positioning system (GPS) or cellular phone antennas, such as disclosed in U.S. Pat. No. 5,971,552, a communication module, such as disclosed in U.S. Pat. No. 5,798,688, a blind spot detection system, such as disclosed in U.S. Pat. Nos. 5,929,786 and/or 5,786,772, a high/low headlamp controller, such as disclosed in U.S. Pat. Nos. 5,796,094 and/or 5,715,093, transmitters and/or receivers, such as a garage door opener or the like, a digital network, such as described in U.S. Pat. No. 5,798,575, a memory mirror system, such as disclosed in U.S. Pat. No. 5,796,176, a hands-free phone attachment, a video device for internal cabin surveillance and/or video telephone function, such as disclosed in U.S. Pat. Nos. 5,760,962 and/or 5,877,897, a remote keyless entry receiver or system or circuitry and/or a universal garage door opening system or circuitry (such as the types disclosed in U.S. Pat. Nos. 6,396,408;

6,362,771; 5,798,688 and 5,479,155, and/or U.S. pat. application, Ser. No. 10/770,736, filed Feb. 3, 2004, now U.S. Pat. No. 7,023,322), lights, such as map reading lights or one or more other lights or illumination sources, such as disclosed in U.S. Pat. Nos. 6,690,268; 5,938,321; 5,813,745; 5,820,245; 5,673,994; 5,649,756; 5,178,448; 5,671,996; 4,646,210; 4,733,336; 4,807,096; 6,042,253; and/or 5,669,698, and/or U.S. pat. application, Ser. No. 10/054,633, filed Jan. 22, 2002, now U.S. Pat. No. 7,195,381, microphones, such as disclosed in U.S. Pat. Nos. 6,243,003; 6,278,377; and/or 6,420,975, and/or PCT Application No. PCT/US03/30877, filed Oct. 1, 2003, speakers, a compass or compass system, such as disclosed in U.S. Pat. Nos. 5,924,212; 4,862,594; 4,937,945; 5,131,154; 5,255,442; and/or 5,632,092, and/or U.S. pat. application, Ser. No. 10/456,599, filed Jun. 6, 2003, now U.S. Pat. No. 7,004,593, a navigation system, such as described in U.S. Pat. No. 6,477,464, and U.S. pat. applications, Ser. No. 10/456,599, filed Jun. 6, 2003, now U.S. Pat. No. 7,004,593; Ser. No. 10/287,178, filed Nov. 4, 2002, now U.S. Pat. No. 6,678,614; Ser. No. 10/645,762, filed Aug. 20, 2003, now U.S. Pat. No. 7,167,796; and Ser. No. 10/422,378, filed Apr. 24, 2003, now U.S. Pat. No. 6,946,978; and/or PCT Application No. PCT/US03/40611, filed Dec. 19, 2003, a tire pressure monitoring system, such as the types disclosed in U.S. Pat. Nos. 6,294,989; 6,445,287; and/or 6,472,979, and/or in U.S. pat. application, Ser. No. 10/206,495, filed Jul. 26, 2002, now U.S. Pat. No. 6,731,205, a seat occupancy detector, a trip computer, a telematics system, such as an ONSTAR[®] system or the like, and/or any other desired accessory or system or the like (with all of the above-referenced patents and patent applications and PCT applications being commonly assigned to Donnelly Corporation, and with the disclosures of all of the above referenced patents and patent applications and PCT applications being hereby incorporated herein by reference in their entireties).

[00124] Optionally, a vehicle compass or compass system may comprise a printed circuit board and may be positioned within a pod or the like that may be fixedly mounted in the vehicle. The compass may be initially calibrated (such as at the assembly plant or the like) via a small Helmholtz coil that may accommodate the small circuit board or pod. The coil induces a field to calibrate the compass, such as described in U.S. provisional application, Ser. No. 60/467,899, filed May 5, 2003, which is hereby incorporated herein by reference in its entirety. The induced field in the miniature Helmholtz coil may be controlled via the use of a highly permeable magnetic shielding material that may enclose the miniature

Helmholtz coil with only a small slot for the circuit board or compass pod to enter through. Such a set up may allow the compass pod manufacturer to automate and magnetically shield the calibration and test stage of a microprocessor-based compass. The calibration process may utilize an indexing rotary table that may rotate to move a compass pod from a loading bay to a calibration bay. The shielded Helmholtz coil may be adjacent to the rotary table and may be shuttled back and forth to align with the rotary table to receive a compass pod therefrom. The rotary table may rotate to move a calibrated compass pod (after it leaves the miniature Helmholtz coil) from the calibration bay to a final functional test station to test the calibrated compass pod.

[00125] Therefore, the present invention provides a wide angle or multi-radius single substrate or reflective element which may provide an enhanced field of view for an interior or exterior rearview mirror assembly. The wide angle or multi-radius single element reflector may have an anti-abrasion coating or ultrathin glass film conformed to and applied to the exterior curved surface of the substrate. The substrate may be molded or extruded into the desired shape and may be formed into an elongated strip or sheet, whereby the anti-abrasion coating or film may be applied along the strip before the strip is cut into the desired substrates. The present invention thus provides a single element wide angle or multi-radius substrate which has enhanced scratch resistance. A polymeric reflective film may be laminated, adhered or otherwise applied to the opposite inner surface of the substrate or extruded strip while the anti-abrasion coating or film is applied to the exterior surface. Optionally, a reflective film or layer may be applied to the exterior surface of the substrate and an anti-abrasion film or layer may be applied to the reflective film or layer.

[00126] Changes and modifications in the specifically described embodiments can be carried out without departing from the principles of the present invention, which is intended to be limited only by the scope of the appended claims, as interpreted according to the principles of patent law.

The embodiments of the invention in which an exclusive property or privilege is claimed are defined as follows:

1. An exterior sideview mirror assembly suitable for use on a vehicle, said exterior sideview mirror assembly comprising:

a mirror housing;

a mirror backing plate element;

wherein said mirror backing plate element is movable within said mirror housing by an electrically-operable actuator;

a main plano mirror element fixedly disposed at a first portion of said mirror backing plate element;

said main plano mirror element having a first primary field of view rearward of a vehicle equipped with said exterior sideview mirror assembly;

an auxiliary non-plano curved mirror element fixedly disposed at a second portion of said mirror backing plate element;

wherein said main plano mirror element and said auxiliary non-plano curved mirror element are adjacently disposed at said mirror backing plate element in a side-by-side relationship and are not superimposed with one mirror element on top of the other mirror element;

said auxiliary non-plano curved mirror element having a second auxiliary field of view rearward of the equipped vehicle;

wherein said first primary field of view of said main plano mirror element overlaps said second auxiliary field of view of said auxiliary non-plano curved mirror element;

wherein said auxiliary non-plano curved mirror element that is at said second portion of said mirror backing plate element is angled relative to said main plano mirror element that is at said first portion of said mirror backing plate element;

wherein said mirror backing plate element mounts to said actuator such that movement of said mirror backing plate element by said actuator simultaneously and similarly moves said main plano mirror element and said auxiliary non-plano curved mirror element;

wherein said mirror backing plate element comprises a polymeric molding;

wherein said main plano mirror element comprises a generally flat glass substrate having a surface coated with a metallic reflector coating;

wherein the overall rearward field of view of said main plano mirror element combined with said auxiliary non-plano curved mirror element is at least about 25 degrees relative to the side of the equipped vehicle; and

wherein the overall rearward field of view of said main plano mirror element combined with said auxiliary non-plano curved mirror element is less than about 50 degrees relative to the side of the equipped vehicle.

2. The exterior sideview mirror assembly of claim 1, wherein said auxiliary non-plano curved mirror element comprises a reflector-coated convex-curved substrate and wherein said second portion of said mirror backing plate element is convex-curved and wherein said auxiliary non-plano curved mirror element has a spherical curvature.

3. The exterior sideview mirror assembly of claim 2, wherein said second portion of said mirror backing plate element has a curvature at least partially matching said spherical curvature of said auxiliary non-plano curved mirror element.

4. The exterior sideview mirror assembly of claim 1, wherein, when used in the exterior sideview mirror assembly of the equipped vehicle, said main plano mirror element has a rearward field of view that generally subtends an angle of less than about 20 degrees relative to the side of the equipped vehicle, and wherein said auxiliary non-plano curved mirror element has a rearward field of view that generally subtends an angle that is in the range from about 15 degrees relative to the side of the equipped vehicle to about 50 degrees relative to the side of the equipped vehicle.

5. The exterior sideview mirror assembly of claim 1, wherein said main plano mirror element has an X-axis and a Y-axis and wherein, when disposed at said second portion of said mirror backing plate element, said auxiliary non-plano curved mirror element is at least one of (a) tilted generally downward with respect to the Y-axis of said main plano mirror element by an angle that is in the range from about 0.75 degrees to about 5 degrees

and (b) tilted generally forwardly with respect to the X-axis of said main plano mirror element by an angle that is in the range from about 0.75 degrees to about 5 degrees.

6. The exterior sideview mirror assembly of claim 1, wherein said second auxiliary field of view rearward of the equipped vehicle views into a blind spot in a side lane adjacent the side of the equipped vehicle at which said exterior sideview mirror assembly is attached, and wherein said blind spot is generally outside the rearward field of view of said main plano mirror element when said main plano mirror element is viewed by a driver of the equipped vehicle when said exterior sideview mirror assembly is attached at the side of the equipped vehicle.

7. The exterior sideview mirror assembly of claim 1, wherein said auxiliary non-plano curved mirror element comprises a reflector-coated convex-curved glass substrate and wherein said second portion of said mirror backing plate element is convex-curved and wherein said auxiliary non-plano curved mirror element has a spherical curvature and wherein said second portion of said mirror backing plate element has curvature substantially matching said spherical curvature of said auxiliary non-plano curved mirror element.

8. The exterior sideview mirror assembly of claim 1, wherein said first primary field of view of said main plano mirror element overlaps said second auxiliary field of view of said auxiliary non-plano curved mirror element by between about 2 degrees and about 20 degrees.

9. The exterior sideview mirror assembly of claim 1, wherein said main plano mirror element has a fixed reflectance and wherein said auxiliary non-plano curved mirror element has a fixed reflectance.

10. The exterior sideview mirror assembly of claim 1, wherein said main plano mirror element is disposed at said mirror backing plate element by at least one of an adhesive attachment and a mechanical attachment and wherein said auxiliary non-plano curved mirror element is disposed at said mirror backing plate element by at least one of an

adhesive attachment and a mechanical attachment, and wherein said auxiliary non-plano curved mirror element comprises a bent glass substrate having a surface coated with a metallic reflector.

11. The exterior sideview mirror assembly of claim 1, wherein said main plano mirror element comprises a substrate having a surface coated with a metallic reflector coating and wherein said auxiliary non-plano curved mirror element comprises a substrate having a surface coated with a metallic reflector coating, and wherein said second portion of said mirror backing plate element comprises a curvature corresponding to a curvature of said auxiliary non-plano curved mirror element, and wherein said second portion of said mirror backing plate element comprises at least one of (a) a spherical curvature, (b) an aspherical curvature and (c) a multiradius curvature.

12. The exterior sideview mirror assembly of claim 1, wherein said auxiliary non-plano curved mirror element comprises a heater element operable to demist/deice the outmost surface of said auxiliary non-plano curved mirror element when said auxiliary non-plano curved mirror element is disposed at said mirror backing plate element and when said exterior sideview mirror assembly is attached and operated at the side of the equipped vehicle, and wherein said exterior sideview mirror assembly comprises a driver-side exterior sideview mirror assembly.

13. The exterior sideview mirror assembly of claim 1, wherein said exterior sideview mirror assembly comprises a door-mounted driver-side exterior sideview mirror assembly of the equipped vehicle, and wherein said auxiliary non-plano curved mirror element comprises a glass substrate having a surface coated with a metallic reflector coating, and wherein said metallic reflector coating is selected from the group consisting of (i) a chromium coating, (ii) a titanium coating, (iii) a rhodium coating, (iv) a metal-alloy coating, (v) a nickel alloy coating, (vi) an aluminum coating and (vii) a silver coating.

14. The exterior sideview mirror assembly of claim 1, wherein said auxiliary non-plano curved mirror element comprises a metallic reflector coating and wherein said auxiliary non-plano curved mirror element comprises a spherically bent curved glass substrate.

15. An exterior sideview mirror assembly suitable for use on a vehicle, said exterior sideview mirror assembly comprising:

- a mirror housing;
- a mirror backing plate element;
- wherein said mirror backing plate element is movable within said mirror housing by an electrically-operable actuator;
- a main plano mirror element fixedly disposed at a first portion of said mirror backing plate element;
- said main plano mirror element having a first primary field of view rearward of a vehicle equipped with said exterior sideview mirror assembly;
- an auxiliary non-plano curved mirror element fixedly disposed at a second portion of said mirror backing plate element;
- wherein said auxiliary non-plano curved mirror element comprises a metallic reflector coating and wherein said auxiliary non-plano curved mirror element comprises a curved glass substrate;
- wherein said main plano mirror element and said auxiliary non-plano curved mirror element are adjacently disposed at said mirror backing plate element in a side-by-side relationship and are not superimposed with one mirror element on top of the other mirror element;
- wherein said second portion of said mirror backing plate element has a curvature at least partially matching the curvature of said auxiliary non-plano curved mirror element;
- said auxiliary non-plano curved mirror element having a second auxiliary field of view rearward of the equipped vehicle;
- wherein said first primary field of view of said main plano mirror element overlaps said second auxiliary field of view of said auxiliary non-plano curved mirror element;
- wherein said auxiliary non-plano curved mirror element that is at said second portion of said mirror backing plate element is angled relative to said main plano mirror element that is at said first portion of said mirror backing plate element;
- wherein said mirror backing plate element mounts to said actuator such that movement of said mirror backing plate element by said actuator simultaneously and

similarly moves said main plano mirror element and said auxiliary non-plano curved mirror element;

wherein said mirror backing plate element comprises a polymeric molding;

wherein said main plano mirror element comprises a generally flat glass substrate having a surface coated with a metallic reflector coating;

wherein the overall rearward field of view of said main plano mirror element combined with said auxiliary non-plano curved mirror element is at least about 25 degrees relative to the side of the equipped vehicle; and

wherein the overall rearward field of view of said main plano mirror element combined with said auxiliary non-plano curved mirror element is less than about 50 degrees relative to the side of the equipped vehicle.

16. The exterior sideview mirror assembly of claim 15, wherein, when used in the exterior sideview mirror assembly of the equipped vehicle, said main plano mirror element has a rearward field of view that generally subtends an angle of less than about 20 degrees relative to the side of the equipped vehicle, and wherein said auxiliary non-plano curved mirror element has a rearward field of view that generally subtends an angle that is in the range from about 15 degrees relative to the side of the equipped vehicle to about 50 degrees relative to the side of the equipped vehicle.

17. The exterior sideview mirror assembly of claim 15, wherein said main plano mirror element has an X-axis and a Y-axis and wherein, when disposed at said second portion of said mirror backing plate element, said auxiliary non-plano curved mirror element is at least one of (a) tilted generally downward with respect to the Y-axis of said main plano mirror element by an angle that is in the range from about 0.75 degrees to about 5 degrees and (b) tilted generally forwardly with respect to the X-axis of said main plano mirror element by an angle that is in the range from about 0.75 degrees to about 5 degrees.

18. An exterior sideview mirror assembly suitable for use on a vehicle, said exterior sideview mirror assembly comprising:

a mirror housing;

a mirror backing plate element;

wherein said mirror backing plate element is movable within said mirror housing by an electrically-operable actuator;

a main plano mirror element fixedly disposed at a first portion of said mirror backing plate element;

said main plano mirror element having a first primary field of view rearward of a vehicle equipped with said exterior sideview mirror assembly;

an auxiliary non-plano curved mirror element fixedly disposed at a second portion of said mirror backing plate element;

wherein said main plano mirror element has a fixed reflectance and wherein said auxiliary non-plano curved mirror element has a fixed reflectance;

wherein said main plano mirror element and said auxiliary non-plano curved mirror element are adjacently disposed at said mirror backing plate element in a side-by-side relationship and are not superimposed with one mirror element on top of the other mirror element;

said auxiliary non-plano curved mirror element having a second auxiliary field of view rearward of the equipped vehicle;

wherein said first primary field of view of said main plano mirror element overlaps said second auxiliary field of view of said auxiliary non-plano curved mirror element by between about 2 degrees and about 20 degrees;

wherein said auxiliary non-plano curved mirror element that is at said second portion of said mirror backing plate element is angled relative to said main plano mirror element that is at said first portion of said mirror backing plate element;

wherein said mirror backing plate element mounts to said actuator such that movement of said mirror backing plate element by said actuator simultaneously and similarly moves said main plano mirror element and said auxiliary non-plano curved mirror element;

wherein said mirror backing plate element comprises a polymeric molding;

wherein said main plano mirror element comprises a generally flat glass substrate having a surface coated with a metallic reflector coating;

wherein the overall rearward field of view of said main plano mirror element combined with said auxiliary non-plano curved mirror element is at least about 25 degrees relative to the side of the equipped vehicle; and

wherein the overall rearward field of view of said main plano mirror element combined with said auxiliary non-plano curved mirror element is less than about 50 degrees relative to the side of the equipped vehicle.

19. The exterior sideview mirror assembly of claim 18, wherein, when used in the exterior sideview mirror assembly of the equipped vehicle, said main plano mirror element has a rearward field of view that generally subtends an angle of less than about 20 degrees relative to the side of the equipped vehicle, and wherein said auxiliary non-plano curved mirror element has a rearward field of view that generally subtends an angle that is in the range from about 15 degrees relative to the side of the equipped vehicle to about 50 degrees relative to the side of the equipped vehicle.

20. The exterior sideview mirror assembly of claim 18, wherein said main plano mirror element has an X-axis and a Y-axis and wherein, when disposed at said second portion of said mirror backing plate element, said auxiliary non-plano curved mirror element is at least one of (a) tilted generally downward with respect to the Y-axis of said main plano mirror element by an angle that is in the range from about 0.75 degrees to about 5 degrees and (b) tilted generally forwardly with respect to the X-axis of said main plano mirror element by an angle that is in the range from about 0.75 degrees to about 5 degrees.

EXTENDED FIELD OF VIEW EXTERIOR MIRROR ELEMENT FOR VEHICLE

ABSTRACT

A vehicular exterior sideview mirror assembly includes a main plano mirror element fixedly disposed at a first portion of a mirror backing plate element and an auxiliary non-plano curved mirror element fixedly disposed at a second portion of the backing plate element. The main plano mirror element and the auxiliary non-plano curved mirror element are adjacently disposed at the backing plate element in a side-by-side relationship. The field of view of the main plano mirror element overlaps the field of view of the non-plano curved mirror element. The overall rearward field of view of the main plano mirror element and auxiliary non-plano curved mirror element is at least about 25 degrees relative to the side of the vehicle. The overall rearward field of view of the main plano mirror element and auxiliary non-plano curved mirror element is less than about 50 degrees relative to the side of the vehicle.

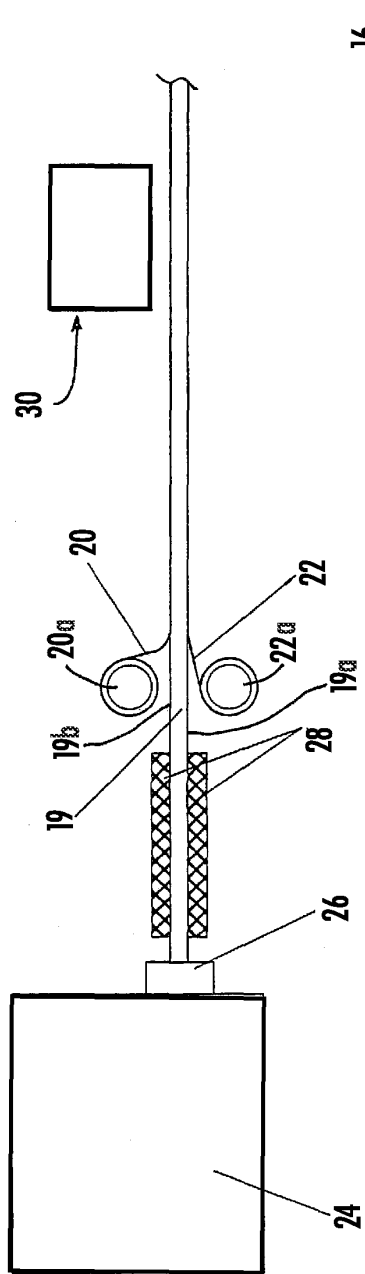

FIG. 5

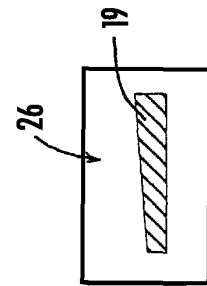

FIG. 5A

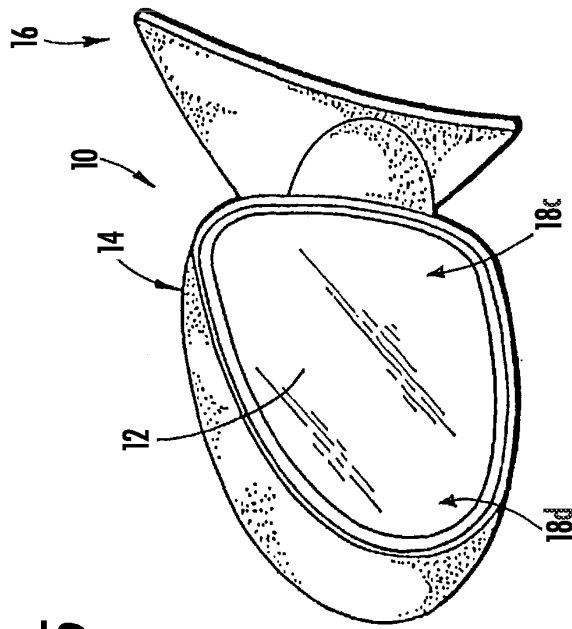

FIG. 7

FIG. 3

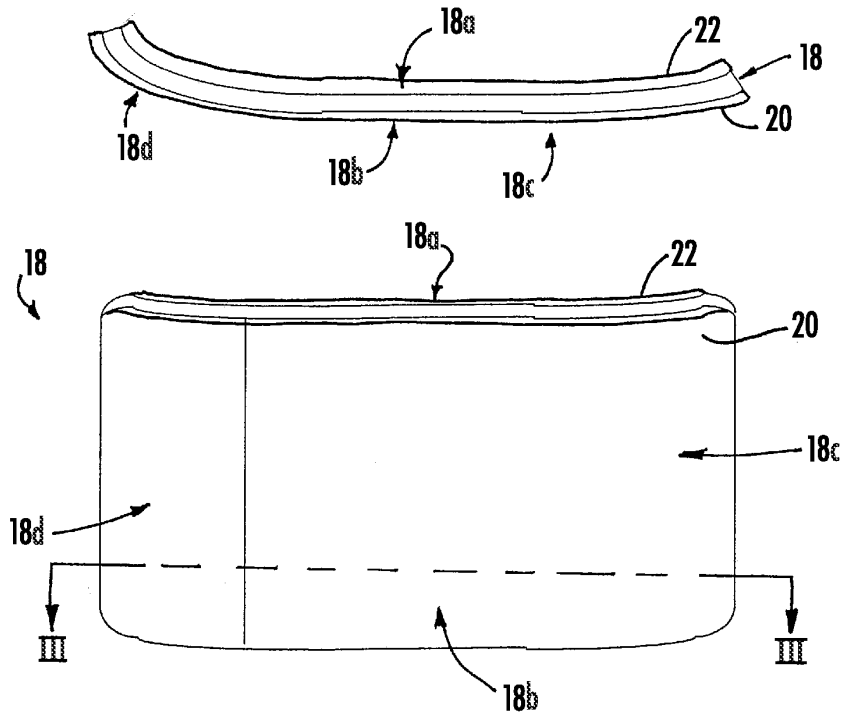
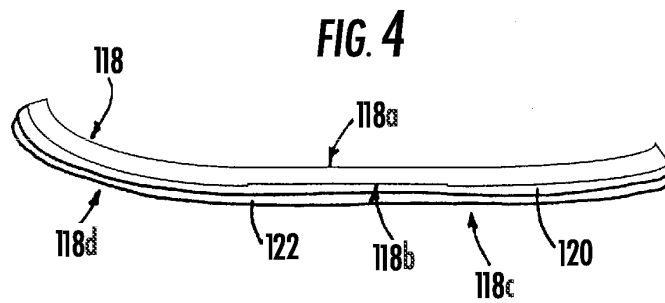

FIG. 2



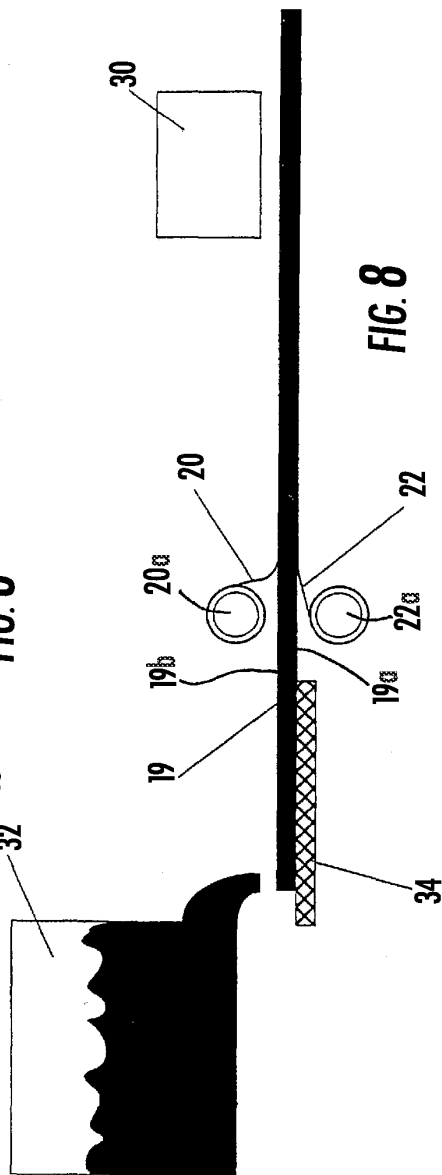
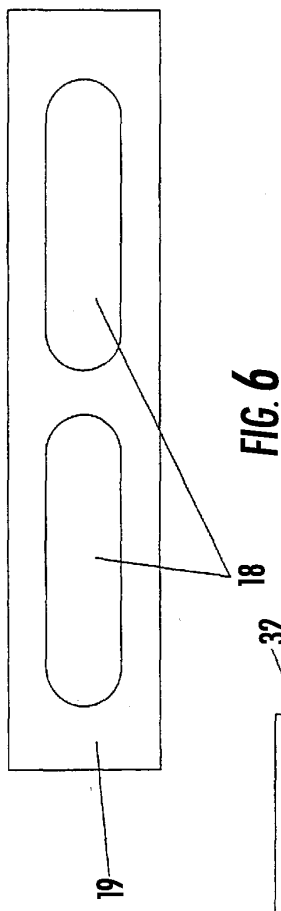
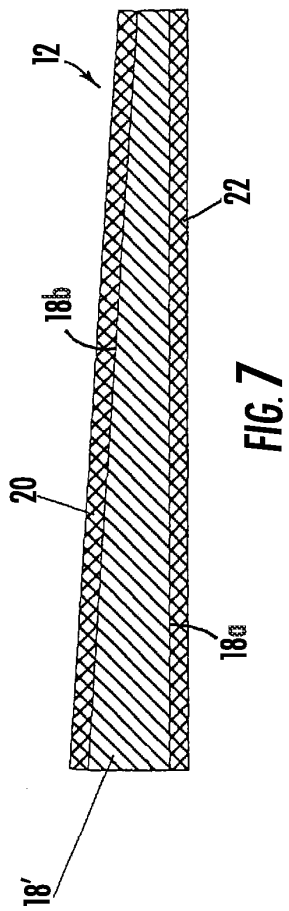

FIG. 8

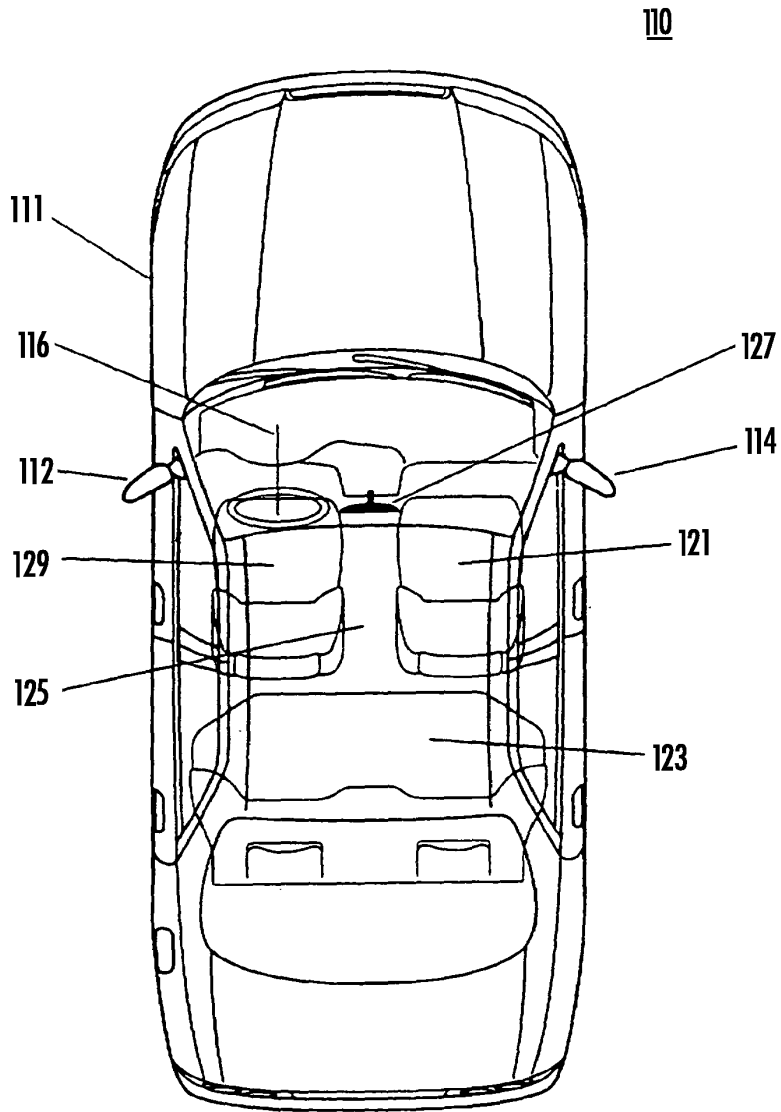

FIG. 9

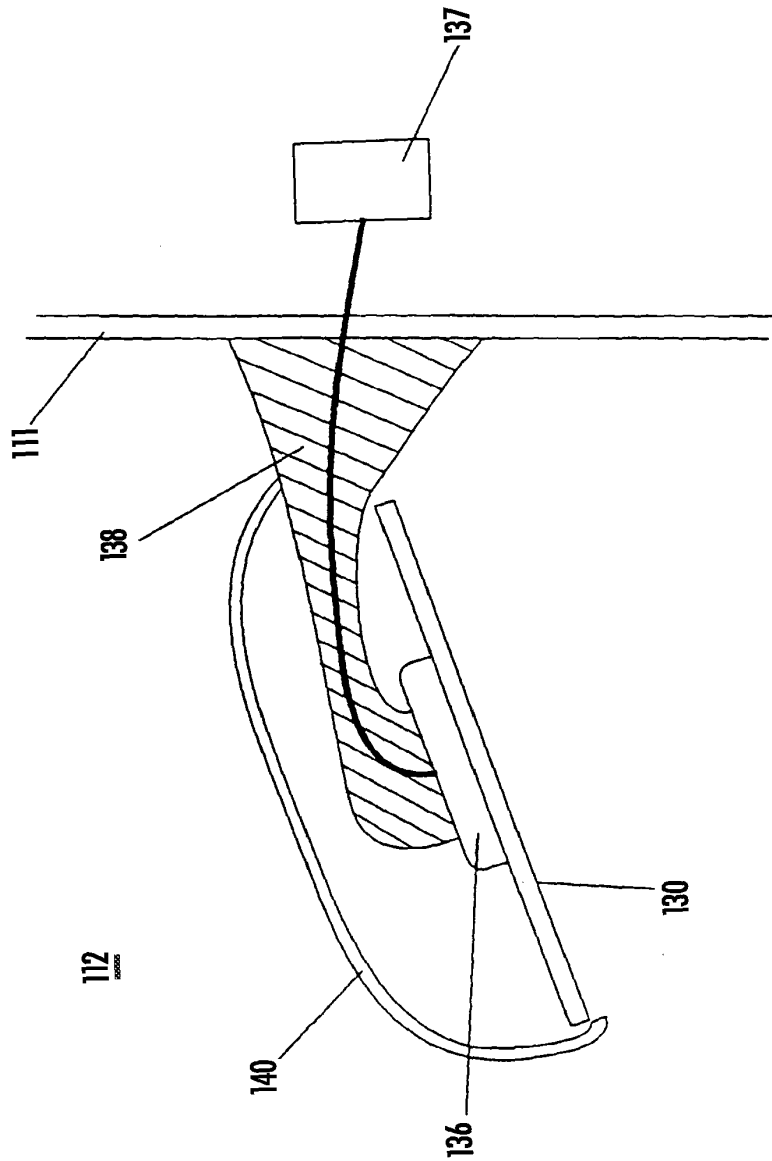

FIG. 10

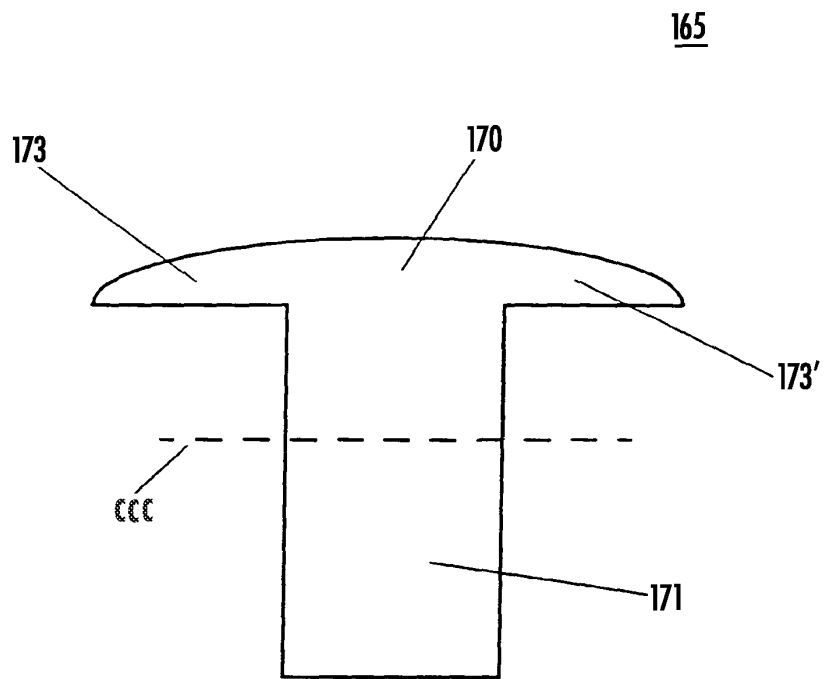
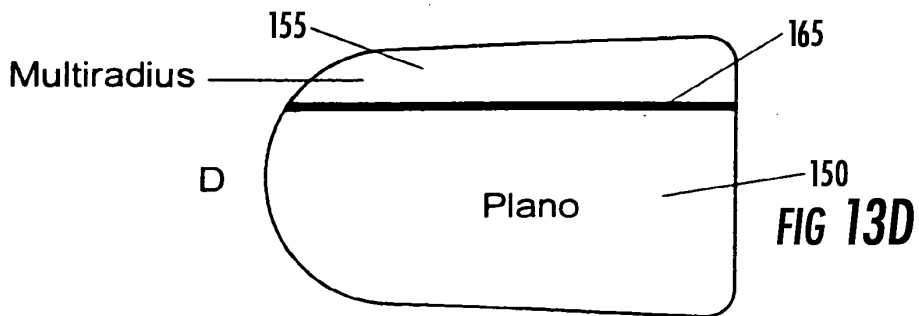
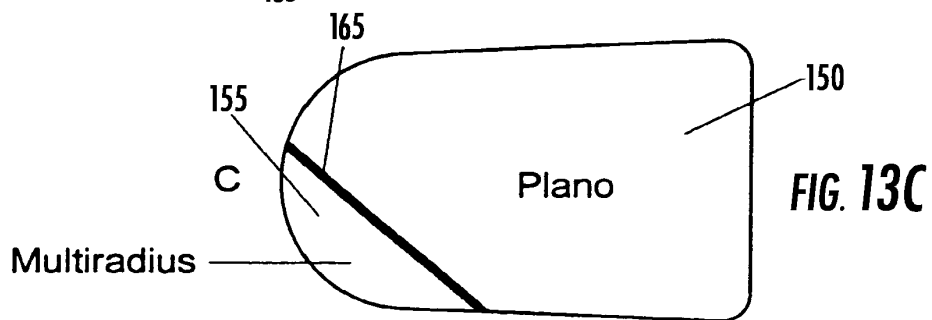
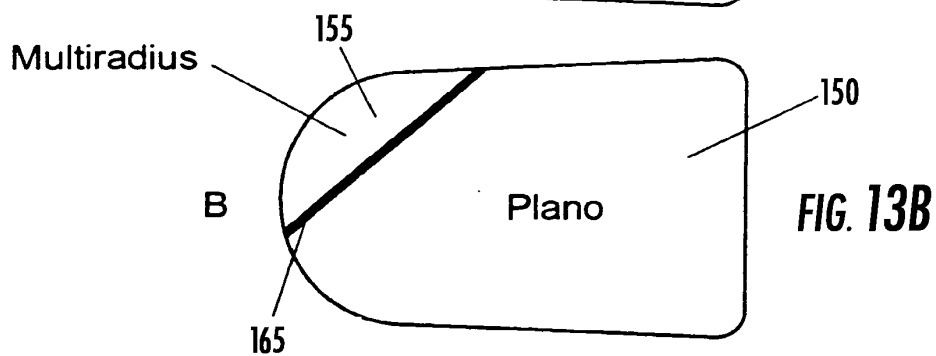
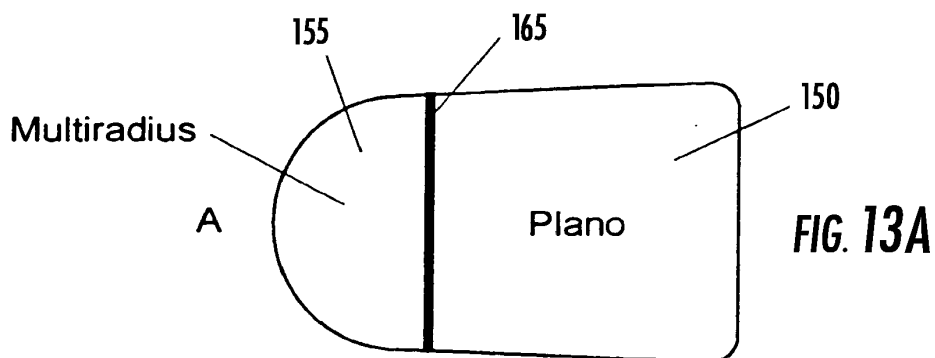
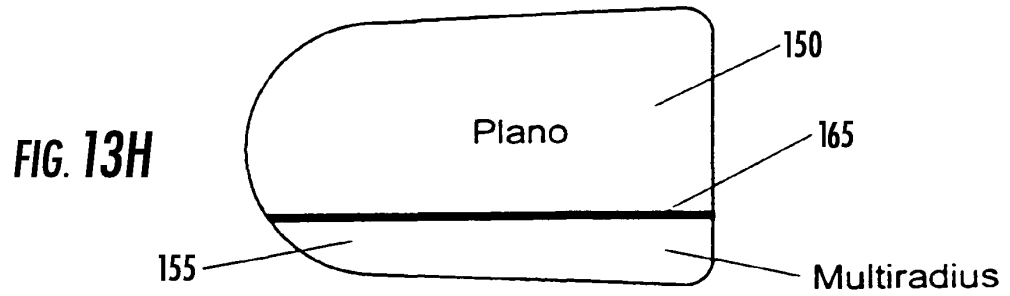
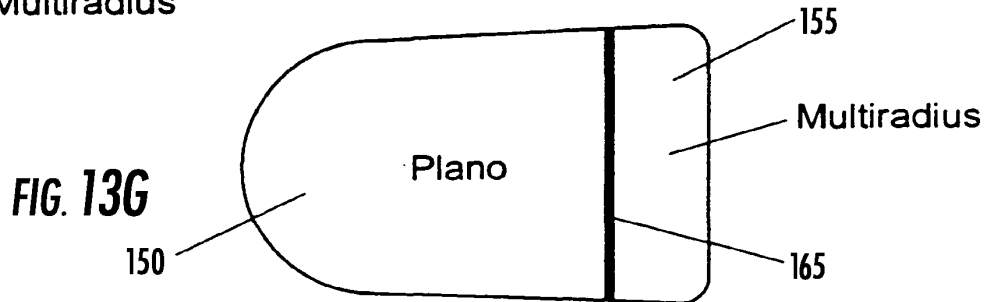
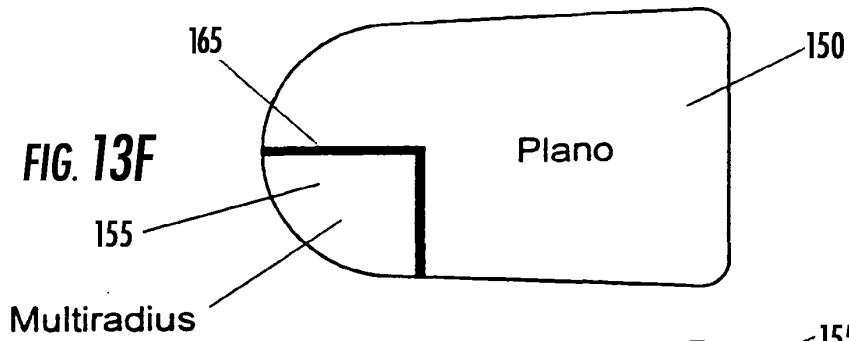
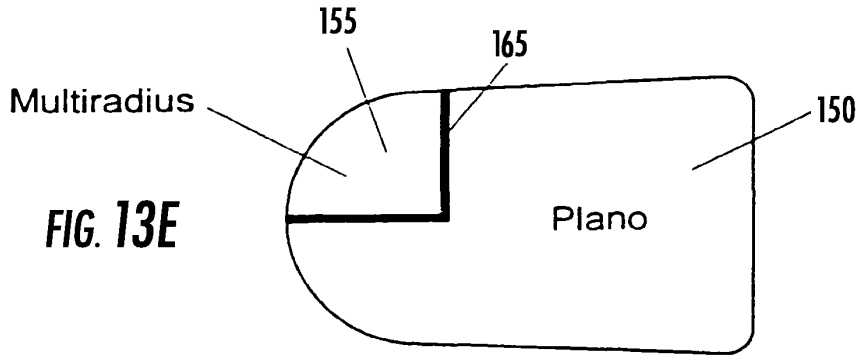

FIG. 12





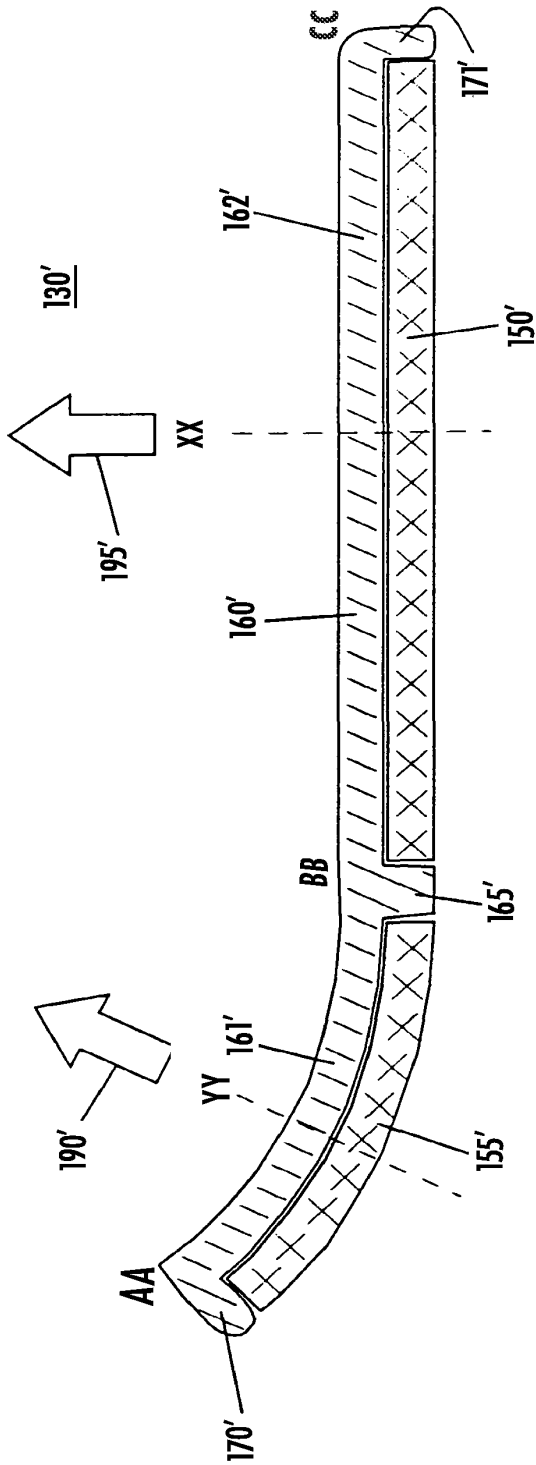

FIG. 14

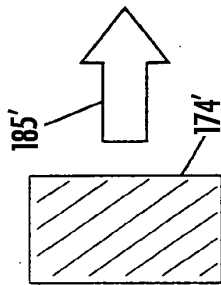

FIG. 14A

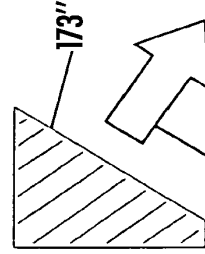

FIG. 14B

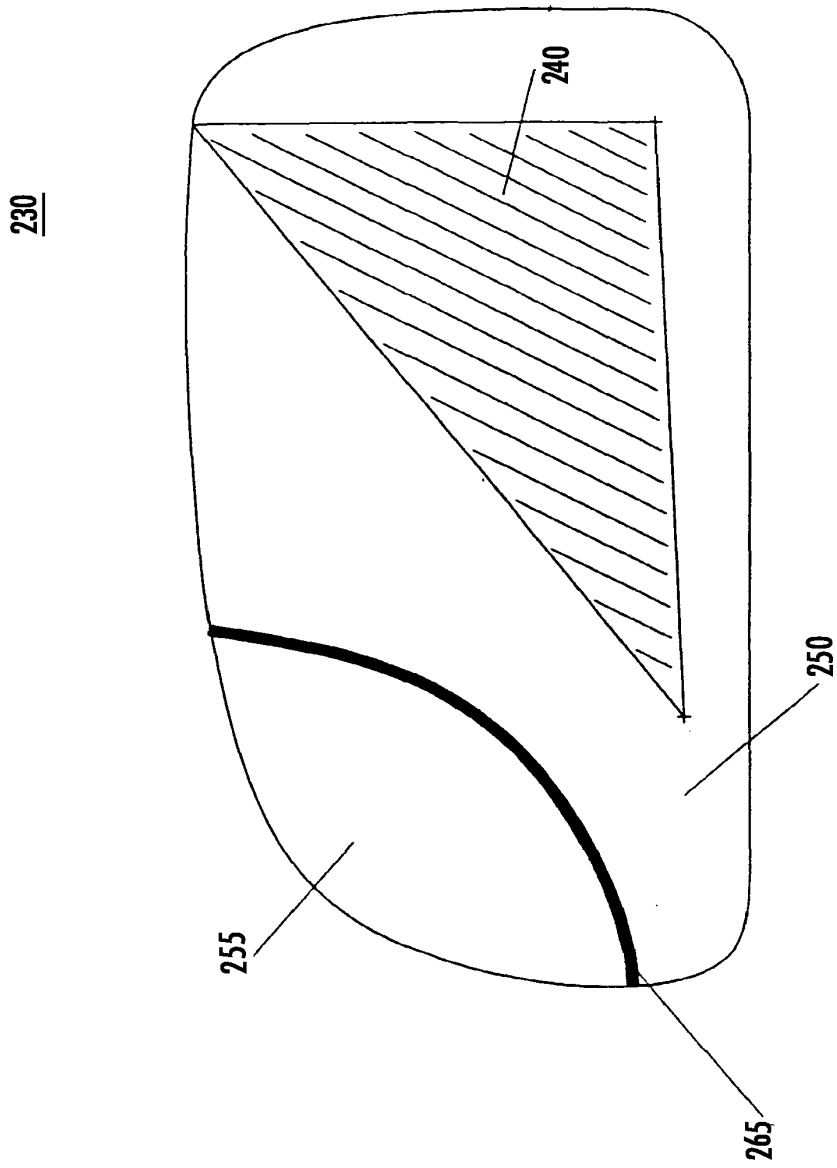

FIG. 15

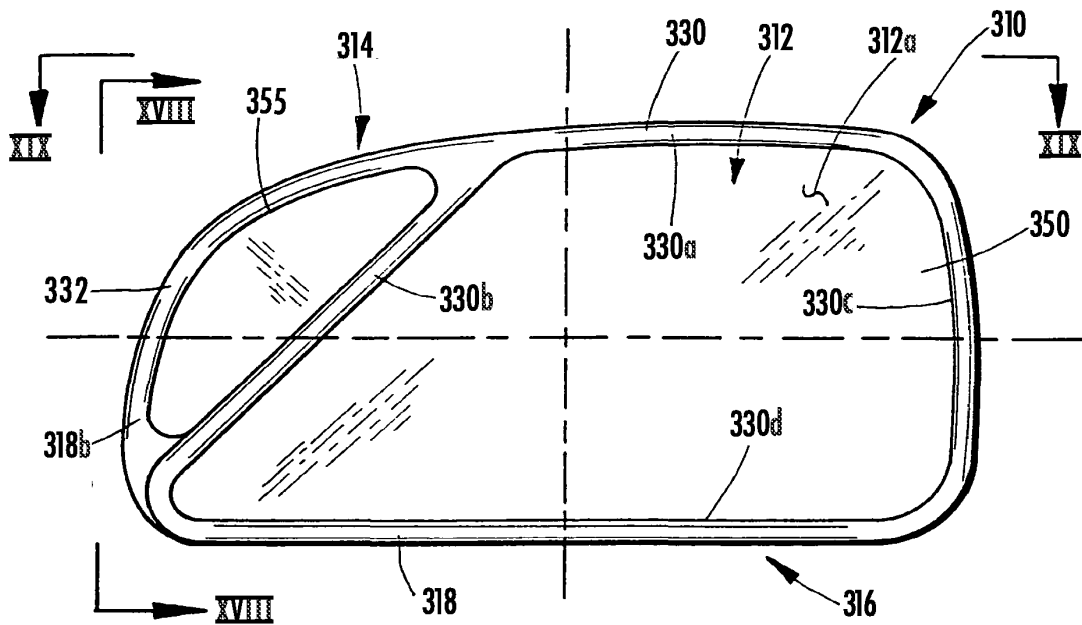

FIG. 16

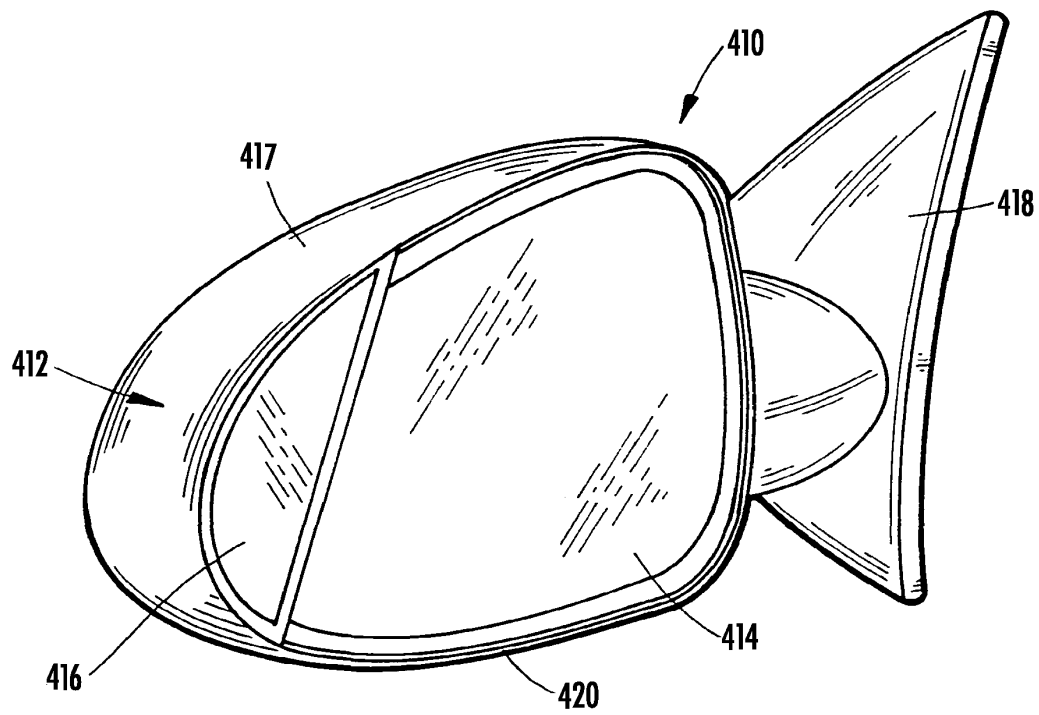

FIG. 23

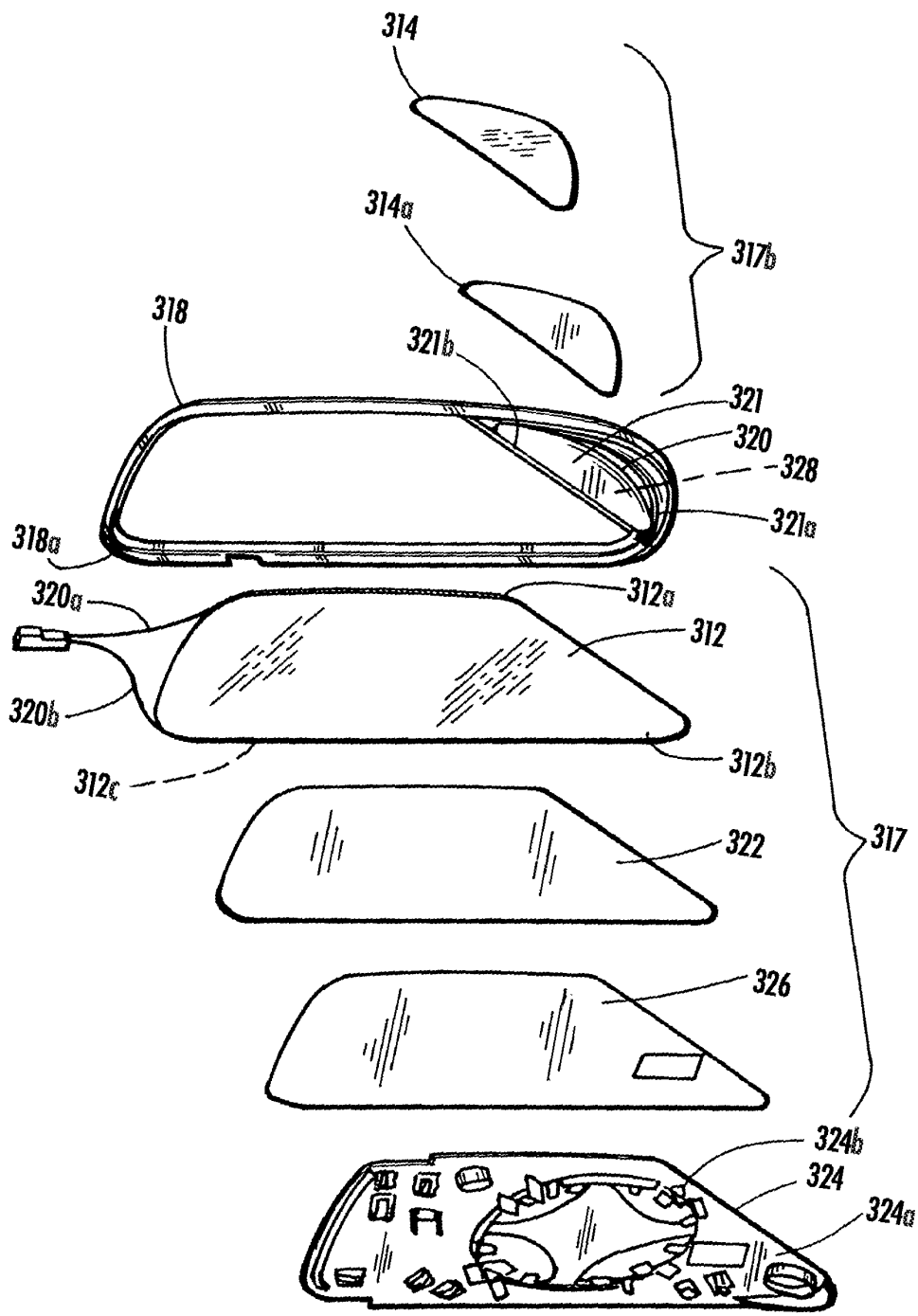
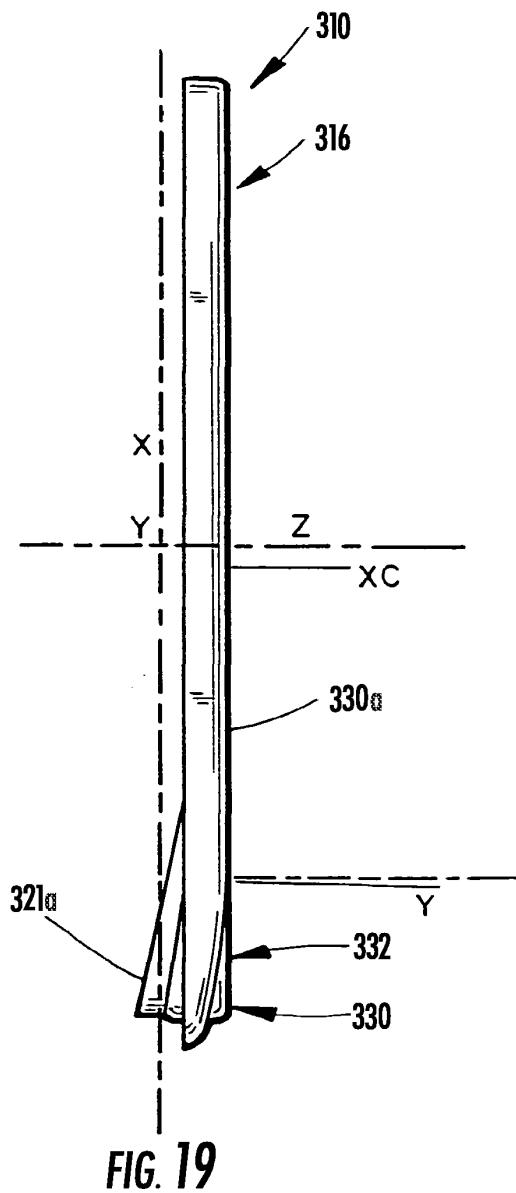
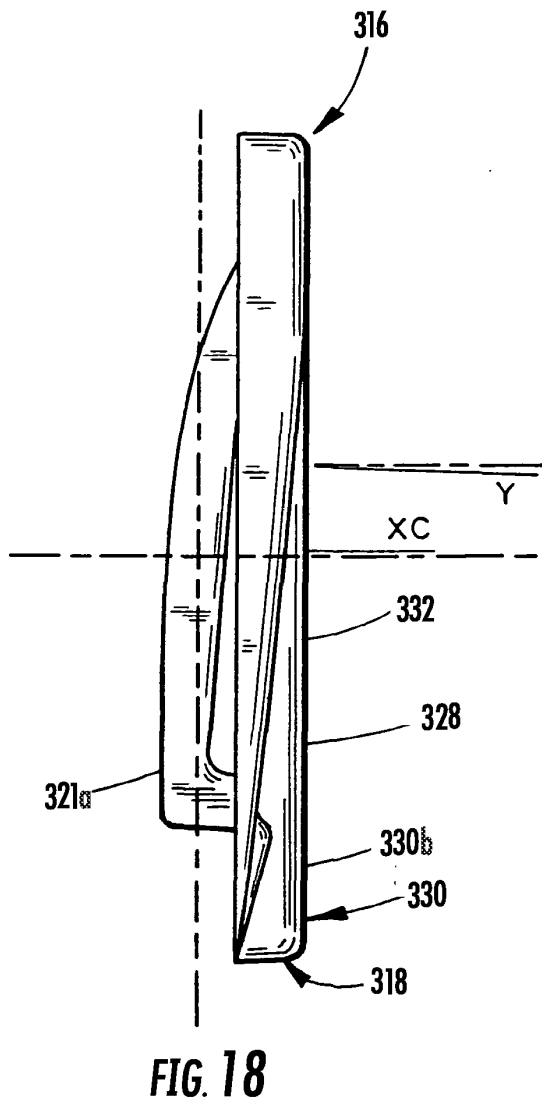

FIG. 17



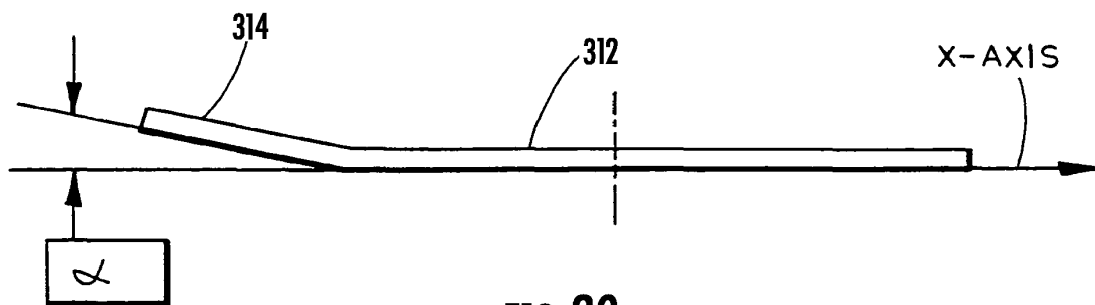

FIG. 20

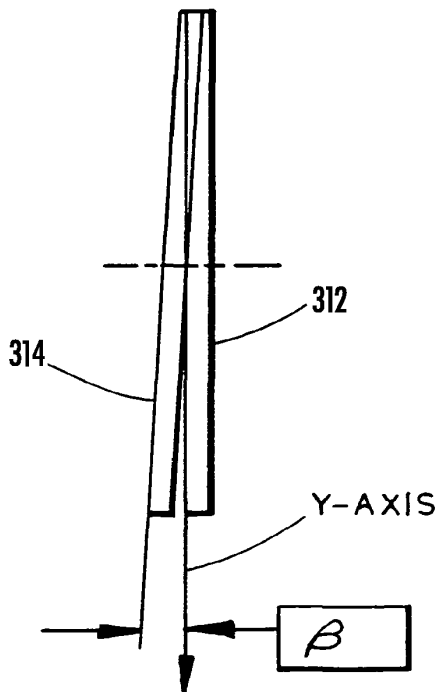

FIG. 21

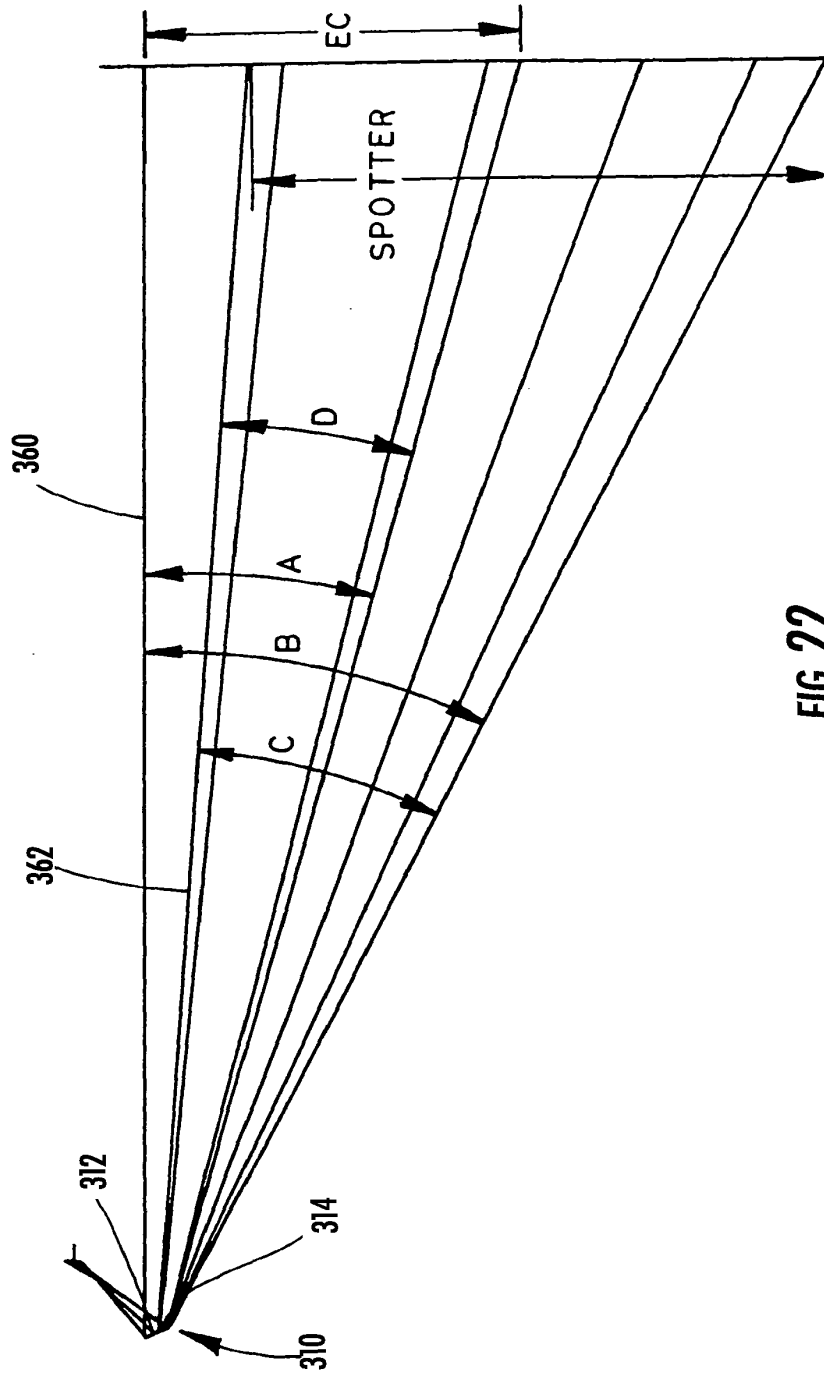

FIG. 22

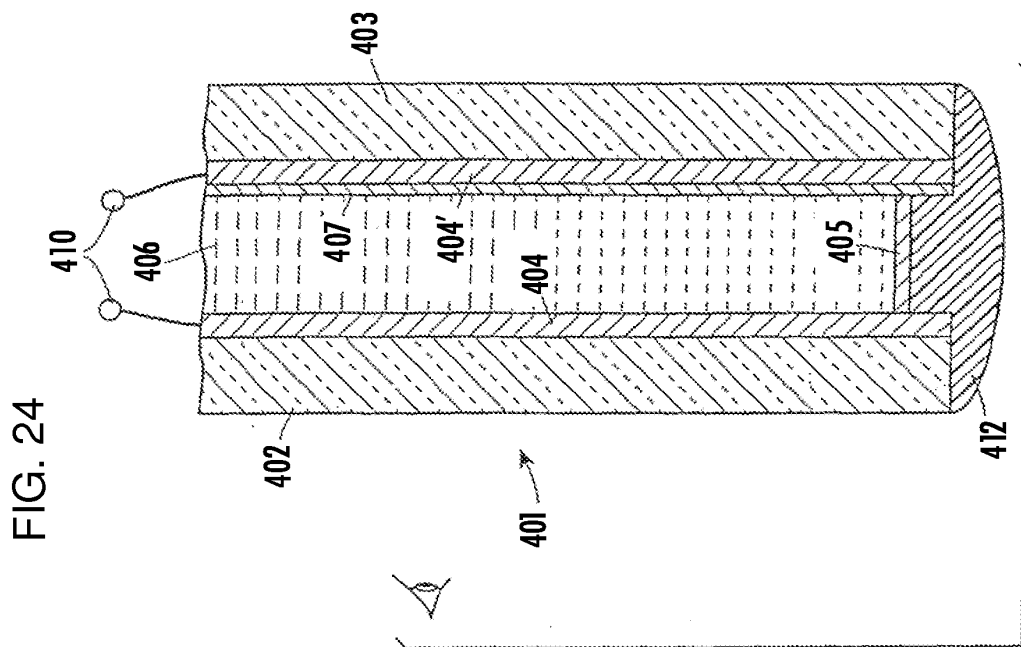

FIG. 25A

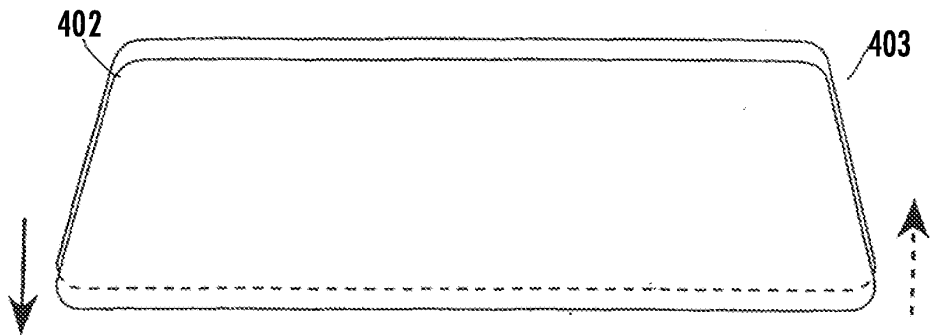

FIG. 25B

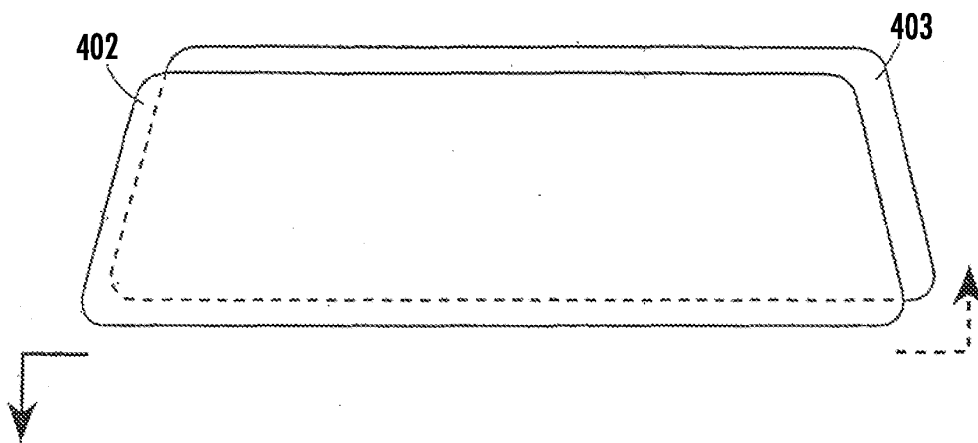

FIG. 25C

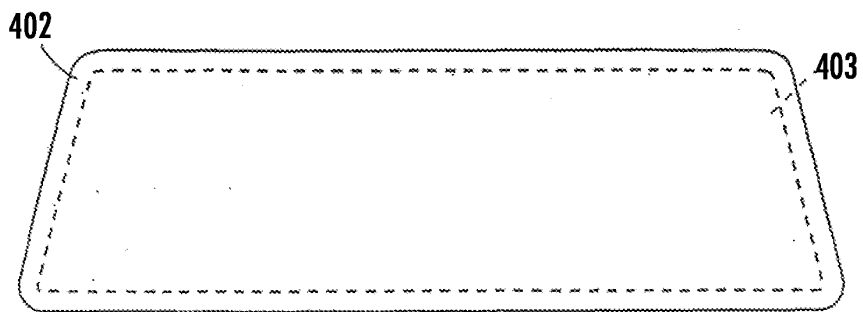

FIG.26A

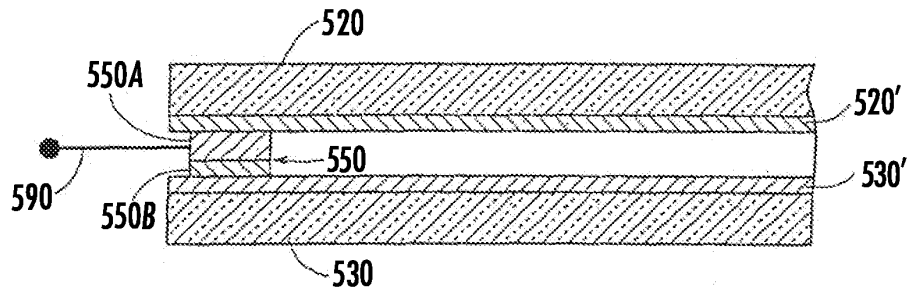
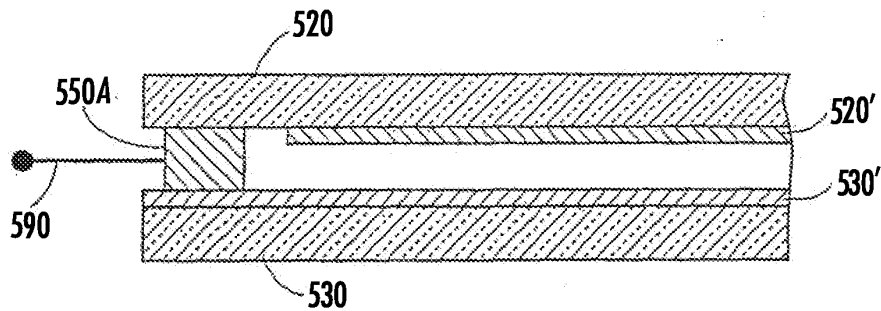

FIG. 26B



Electronic Patent Application Fee Transmittal

Application Number:				
Filing Date:				
Title of Invention:	EXTENDED FIELD OF VIEW EXTERIOR MIRROR ELEMENT FOR VEHICLE			
First Named Inventor/Applicant Name:	Niall R. Lynam			
Filer:	Timothy A. Flory/Amanda Sytsma			
Attorney Docket Number:	DON09 P-2194			
Filed as Large Entity				
Utility under 35 USC 111(a) Filing Fees				
Description	Fee Code	Quantity	Amount	Sub-Total in USD(\$)
Basic Filing:				
Utility application filing	1011	1	280	280
Utility Search Fee	1111	1	600	600
Utility Examination Fee	1311	1	720	720
Pages:				
Claims:				
Miscellaneous-Filing:				
Petition:				
Patent-Appeals-and-Interference:				

Description	Fee Code	Quantity	Amount	Sub-Total in USD(\$)
Post-Allowance-and-Post-Issuance:				
Extension-of-Time:				
Miscellaneous:				
Total in USD (\$)				1600

Electronic Acknowledgement Receipt

EFS ID:	17127030
Application Number:	14054004
International Application Number:	
Confirmation Number:	4390
Title of Invention:	EXTENDED FIELD OF VIEW EXTERIOR MIRROR ELEMENT FOR VEHICLE
First Named Inventor/Applicant Name:	Niall R. Lynam
Customer Number:	15671
Filer:	Timothy A. Flory/Amanda Sytsma
Filer Authorized By:	Timothy A. Flory
Attorney Docket Number:	DON09 P-2194
Receipt Date:	15-OCT-2013
Filing Date:	
Time Stamp:	14:55:36
Application Type:	Utility under 35 USC 111(a)

Payment information:

Submitted with Payment	yes
Payment Type	Credit Card
Payment was successfully received in RAM	\$1600
RAM confirmation Number	1527
Deposit Account	
Authorized User	

File Listing:

Document Number	Document Description	File Name	File Size(Bytes)/ Message Digest	Multi Part /.zip	Pages (if appl.)
-----------------	----------------------	-----------	-------------------------------------	------------------	------------------

1	Transmittal of New Application	Transmittal.pdf	107381 b1c591781363f323ab88f0b67f70b8601e45c770	no	1
Warnings:					
Information:					
2	Miscellaneous Incoming Letter	RequestforContinuation.pdf	36312 02a6e1657de9b54618d6e8e43ff1a8e960857d3	no	6
Warnings:					
Information:					
3	Application Data Sheet	P2194ApplicationDataSheet.pdf	1503600 fd68882cf3ae2649cfd7ea8092aaf747aac43006	no	7
Warnings:					
Information:					
4	Oath or Declaration filed	Declaration.pdf	205791 72bf8ef73c1925f93973816df4ee2e8b8801f30c	no	1
Warnings:					
Information:					
5	Power of Attorney	POA.pdf	526661 cc6e9d3ada2ef0e4b45477b6103060834f2be02	no	2
Warnings:					
Information:					
6		Specification.pdf	270883 3fd1540138acf127805844e1023b8dfcbf26ede6	yes	54
	Multipart Description/PDF files in .zip description				
	Document Description		Start	End	
	Specification		1	45	
	Claims		46	53	
Abstract		54	54		
Warnings:					
Information:					
7	Drawings-only black and white line drawings	P2194Drawings.pdf	1140755 a3868e1cd9f28e19d1db6f1d4cc0b785256cae49	no	19
Warnings:					
Information:					

8	Fee Worksheet (SB06)	fee-info.pdf	33030	no	2
			9a5c9f66bfd191fd907b47ca0f0781bb5fd7012b		

Warnings:

Information:

Total Files Size (in bytes):	3824413
-------------------------------------	---------

This Acknowledgement Receipt evidences receipt on the noted date by the USPTO of the indicated documents, characterized by the applicant, and including page counts, where applicable. It serves as evidence of receipt similar to a Post Card, as described in MPEP 503.

New Applications Under 35 U.S.C. 111

If a new application is being filed and the application includes the necessary components for a filing date (see 37 CFR 1.53(b)-(d) and MPEP 506), a Filing Receipt (37 CFR 1.54) will be issued in due course and the date shown on this Acknowledgement Receipt will establish the filing date of the application.

National Stage of an International Application under 35 U.S.C. 371

If a timely submission to enter the national stage of an international application is compliant with the conditions of 35 U.S.C. 371 and other applicable requirements a Form PCT/DO/EO/903 indicating acceptance of the application as a national stage submission under 35 U.S.C. 371 will be issued in addition to the Filing Receipt, in due course.

New International Application Filed with the USPTO as a Receiving Office

If a new international application is being filed and the international application includes the necessary components for an international filing date (see PCT Article 11 and MPEP 1810), a Notification of the International Application Number and of the International Filing Date (Form PCT/RO/105) will be issued in due course, subject to prescriptions concerning national security, and the date shown on this Acknowledgement Receipt will establish the international filing date of the application.



UNITED STATES PATENT AND TRADEMARK OFFICE

UNITED STATES DEPARTMENT OF COMMERCE
United States Patent and Trademark Office
Address: COMMISSIONER FOR PATENTS
P.O. Box 1450
Alexandria, Virginia 22313-1450
www.uspto.gov

Table with 7 columns: APPLICATION NUMBER, FILING or 371(c) DATE, GRP ART UNIT, FIL FEE REC'D, ATTY. DOCKET NO, TOT CLAIMS, IND CLAIMS. Row 1: 14/054,004, 10/15/2013, 2872, 1600, DON09 P-2194, 20, 3

CONFIRMATION NO. 4390

15671
Gardner, Linn, Burkhardt & Flory, LLP
2851 Charlevoix Dr., SE, Suite 207
Grand Rapids, MI 49546

FILING RECEIPT



Date Mailed: 11/04/2013

Receipt is acknowledged of this non-provisional patent application. The application will be taken up for examination in due course. Applicant will be notified as to the results of the examination. Any correspondence concerning the application must include the following identification information: the U.S. APPLICATION NUMBER, FILING DATE, NAME OF APPLICANT, and TITLE OF INVENTION. Fees transmitted by check or draft are subject to collection. Please verify the accuracy of the data presented on this receipt. If an error is noted on this Filing Receipt, please submit a written request for a Filing Receipt Correction. Please provide a copy of this Filing Receipt with the changes noted thereon. If you received a "Notice to File Missing Parts" for this application, please submit any corrections to this Filing Receipt with your reply to the Notice. When the USPTO processes the reply to the Notice, the USPTO will generate another Filing Receipt incorporating the requested corrections

Inventor(s)

Niall R. Lynam, Holland, MI;

Applicant(s)

Donnelly Corporation, Holland, MI

Assignment For Published Patent Application

Donnelly Corporation, Holland, MI

Power of Attorney: The patent practitioners associated with Customer Number 15671

Domestic Priority data as claimed by applicant

This application is a CON of 13/776,247 02/25/2013 PAT 8562157
and is a CON of 13/776,091 02/25/2013
which is a CON of 13/590,854 08/21/2012 PAT 8550642
which is a CON of 13/336,018 12/23/2011 PAT 8267534
which is a CON of 12/911,274 10/25/2010 PAT 8128243
which is a CON of 12/851,045 08/05/2010 PAT 7934843
which is a CON of 12/197,666 08/25/2008 PAT 7842154
which is a DIV of 10/709,434 05/05/2004 PAT 7420756
which claims benefit of 60/471,872 05/20/2003

Foreign Applications for which priority is claimed (You may be eligible to benefit from the Patent Prosecution Highway program at the USPTO. Please see http://www.uspto.gov for more information.) - None.

Foreign application information must be provided in an Application Data Sheet in order to constitute a claim to foreign priority. See 37 CFR 1.55 and 1.76.

If Required, Foreign Filing License Granted: 10/28/2013

The country code and number of your priority application, to be used for filing abroad under the Paris Convention, is **US 14/054,004**

Projected Publication Date: 02/13/2014

Non-Publication Request: No

Early Publication Request: No
Title

EXTENDED FIELD OF VIEW EXTERIOR MIRROR ELEMENT FOR VEHICLE

Preliminary Class

359

Statement under 37 CFR 1.55 or 1.78 for AIA (First Inventor to File) Transition Applications: No

PROTECTING YOUR INVENTION OUTSIDE THE UNITED STATES

Since the rights granted by a U.S. patent extend only throughout the territory of the United States and have no effect in a foreign country, an inventor who wishes patent protection in another country must apply for a patent in a specific country or in regional patent offices. Applicants may wish to consider the filing of an international application under the Patent Cooperation Treaty (PCT). An international (PCT) application generally has the same effect as a regular national patent application in each PCT-member country. The PCT process **simplifies** the filing of patent applications on the same invention in member countries, but **does not result** in a grant of "an international patent" and does not eliminate the need of applicants to file additional documents and fees in countries where patent protection is desired.

Almost every country has its own patent law, and a person desiring a patent in a particular country must make an application for patent in that country in accordance with its particular laws. Since the laws of many countries differ in various respects from the patent law of the United States, applicants are advised to seek guidance from specific foreign countries to ensure that patent rights are not lost prematurely.

Applicants also are advised that in the case of inventions made in the United States, the Director of the USPTO must issue a license before applicants can apply for a patent in a foreign country. The filing of a U.S. patent application serves as a request for a foreign filing license. The application's filing receipt contains further information and guidance as to the status of applicant's license for foreign filing.

Applicants may wish to consult the USPTO booklet, "General Information Concerning Patents" (specifically, the section entitled "Treaties and Foreign Patents") for more information on timeframes and deadlines for filing foreign patent applications. The guide is available either by contacting the USPTO Contact Center at 800-786-9199, or it can be viewed on the USPTO website at <http://www.uspto.gov/web/offices/pac/doc/general/index.html>.

For information on preventing theft of your intellectual property (patents, trademarks and copyrights), you may wish to consult the U.S. Government website, <http://www.stopfakes.gov>. Part of a Department of Commerce initiative, this website includes self-help "toolkits" giving innovators guidance on how to protect intellectual property in specific countries such as China, Korea and Mexico. For questions regarding patent enforcement issues, applicants may call the U.S. Government hotline at 1-866-999-HALT (1-866-999-4258).

LICENSE FOR FOREIGN FILING UNDER
Title 35, United States Code, Section 184
Title 37, Code of Federal Regulations, 5.11 & 5.15

GRANTED

The applicant has been granted a license under 35 U.S.C. 184, if the phrase "IF REQUIRED, FOREIGN FILING LICENSE GRANTED" followed by a date appears on this form. Such licenses are issued in all applications where the conditions for issuance of a license have been met, regardless of whether or not a license may be required as set forth in 37 CFR 5.15. The scope and limitations of this license are set forth in 37 CFR 5.15(a) unless an earlier license has been issued under 37 CFR 5.15(b). The license is subject to revocation upon written notification. The date indicated is the effective date of the license, unless an earlier license of similar scope has been granted under 37 CFR 5.13 or 5.14.

This license is to be retained by the licensee and may be used at any time on or after the effective date thereof unless it is revoked. This license is automatically transferred to any related applications(s) filed under 37 CFR 1.53(d). This license is not retroactive.

The grant of a license does not in any way lessen the responsibility of a licensee for the security of the subject matter as imposed by any Government contract or the provisions of existing laws relating to espionage and the national security or the export of technical data. Licensees should apprise themselves of current regulations especially with respect to certain countries, of other agencies, particularly the Office of Defense Trade Controls, Department of State (with respect to Arms, Munitions and Implements of War (22 CFR 121-128)); the Bureau of Industry and Security, Department of Commerce (15 CFR parts 730-774); the Office of Foreign Assets Control, Department of Treasury (31 CFR Parts 500+) and the Department of Energy.

NOT GRANTED

No license under 35 U.S.C. 184 has been granted at this time, if the phrase "IF REQUIRED, FOREIGN FILING LICENSE GRANTED" DOES NOT appear on this form. Applicant may still petition for a license under 37 CFR 5.12, if a license is desired before the expiration of 6 months from the filing date of the application. If 6 months has lapsed from the filing date of this application and the licensee has not received any indication of a secrecy order under 35 U.S.C. 181, the licensee may foreign file the application pursuant to 37 CFR 5.15(b).

SelectUSA

The United States represents the largest, most dynamic marketplace in the world and is an unparalleled location for business investment, innovation, and commercialization of new technologies. The U.S. offers tremendous resources and advantages for those who invest and manufacture goods here. Through SelectUSA, our nation works to promote and facilitate business investment. SelectUSA provides information assistance to the international investor community; serves as an ombudsman for existing and potential investors; advocates on behalf of U.S. cities, states, and regions competing for global investment; and counsels U.S. economic development organizations on investment attraction best practices. To learn more about why the United States is the best country in the world to develop technology, manufacture products, deliver services, and grow your business, visit <http://www.SelectUSA.gov> or call +1-202-482-6800.

PATENT APPLICATION FEE DETERMINATION RECORD

Substitute for Form PTO-875

Application or Docket Number
14/054,004

APPLICATION AS FILED - PART I

		(Column 1)	(Column 2)	SMALL ENTITY		OR	OTHER THAN SMALL ENTITY	
FOR		NUMBER FILED	NUMBER EXTRA	RATE(\$)	FEE(\$)		RATE(\$)	FEE(\$)
BASIC FEE (37 CFR 1.16(a), (b), or (c))		N/A	N/A	N/A			N/A	280
SEARCH FEE (37 CFR 1.16(k), (l), or (m))		N/A	N/A	N/A			N/A	600
EXAMINATION FEE (37 CFR 1.16(o), (p), or (q))		N/A	N/A	N/A			N/A	720
TOTAL CLAIMS (37 CFR 1.16(i))		20	minus 20 = *			OR	x 80 =	0.00
INDEPENDENT CLAIMS (37 CFR 1.16(h))		3	minus 3 = *			OR	x 420 =	0.00
APPLICATION SIZE FEE (37 CFR 1.16(s))	If the specification and drawings exceed 100 sheets of paper, the application size fee due is \$310 (\$155 for small entity) for each additional 50 sheets or fraction thereof. See 35 U.S.C. 41(a)(1)(G) and 37 CFR 1.16(s).							0.00
MULTIPLE DEPENDENT CLAIM PRESENT (37 CFR 1.16(j))								0.00
* If the difference in column 1 is less than zero, enter "0" in column 2.				TOTAL			TOTAL	1600

APPLICATION AS AMENDED - PART II

		(Column 1)	(Column 2)	(Column 3)	SMALL ENTITY		OR	OTHER THAN SMALL ENTITY		
AMENDMENT A		CLAIMS REMAINING AFTER AMENDMENT	HIGHEST NUMBER PREVIOUSLY PAID FOR	PRESENT EXTRA	RATE(\$)	ADDITIONAL FEE(\$)		RATE(\$)	ADDITIONAL FEE(\$)	
	Total (37 CFR 1.16(i))	*	Minus	**	=	x	=	OR	x	=
	Independent (37 CFR 1.16(h))	*	Minus	***	=	x	=	OR	x	=
	Application Size Fee (37 CFR 1.16(s))							OR		
	FIRST PRESENTATION OF MULTIPLE DEPENDENT CLAIM (37 CFR 1.16(j))							OR		
				TOTAL ADD'L FEE			OR	TOTAL ADD'L FEE		
AMENDMENT B		CLAIMS REMAINING AFTER AMENDMENT	HIGHEST NUMBER PREVIOUSLY PAID FOR	PRESENT EXTRA	RATE(\$)	ADDITIONAL FEE(\$)		RATE(\$)	ADDITIONAL FEE(\$)	
	Total (37 CFR 1.16(i))	*	Minus	**	=	x	=	OR	x	=
	Independent (37 CFR 1.16(h))	*	Minus	***	=	x	=	OR	x	=
	Application Size Fee (37 CFR 1.16(s))							OR		
	FIRST PRESENTATION OF MULTIPLE DEPENDENT CLAIM (37 CFR 1.16(j))							OR		
				TOTAL ADD'L FEE			OR	TOTAL ADD'L FEE		

* If the entry in column 1 is less than the entry in column 2, write "0" in column 3.
 ** If the "Highest Number Previously Paid For" IN THIS SPACE is less than 20, enter "20".
 *** If the "Highest Number Previously Paid For" IN THIS SPACE is less than 3, enter "3".
 The "Highest Number Previously Paid For" (Total or Independent) is the highest found in the appropriate box in column 1.



UNITED STATES PATENT AND TRADEMARK OFFICE

UNITED STATES DEPARTMENT OF COMMERCE
United States Patent and Trademark Office
Address: COMMISSIONER FOR PATENTS
P.O. Box 1450
Alexandria, Virginia 22313-1450
www.uspto.gov

APPLICATION NUMBER	FILING OR 371(C) DATE	FIRST NAMED APPLICANT	ATTY. DOCKET NO./TITLE
14/054,004	10/15/2013	Niall R. Lynam	DON09 P-2194

CONFIRMATION NO. 4390

POA ACCEPTANCE LETTER

15671
Gardner, Linn, Burkhardt & Flory, LLP
2851 Charlevoix Dr., SE, Suite 207
Grand Rapids, MI 49546



OC00000064663152

Date Mailed: 11/04/2013

NOTICE OF ACCEPTANCE OF POWER OF ATTORNEY

This is in response to the Power of Attorney filed 10/15/2013.

The Power of Attorney in this application is accepted. Correspondence in this application will be mailed to the above address as provided by 37 CFR 1.33.

/spkannathip/

Office of Data Management, Application Assistance Unit (571) 272-4000, or (571) 272-4200, or 1-888-786-0101

IN THE UNITED STATES PATENT AND TRADEMARK OFFICE

Inventor : Niall R. Lynam
Serial No. : 14/054,004
Filing Date : October 15, 2013
For : EXTENDED FIELD OF VIEW EXTERIOR MIRROR ELEMENT FOR VEHICLE

Mail Stop Missing Parts
Commissioner for Patents
P.O. Box 1450
Alexandria, V.A. 22313-1450

Dear Sir or Madam:

REQUEST FOR CORRECTED FILING RECEIPT

Receipt of the official filing receipt for the above-identified patent application is hereby acknowledged. That filing receipt has been reviewed for accuracy and the following errors have been noted:

The Domestic Priority data as claimed by applicant appears as

"This application is a CON of 13/776,247 02/25/2013 PAT 8562157
which is a CON of 13/776,091 02/25/2013
which is a CON of 13/590,854 08/21/2012 PAT 8550642
which is a CON of 13/336,018 12/23/2011 PAT 8267534
which is a CON of 12/911,274 10/25/2010 PAT 8128243
which is a CON of 12/851,045 08/05/2010 PAT 7934843
which is a CON of 12/197,666 08/25/2008 PAT 7842154
which is a CON of 10/709,434 05/05/2004 PAT 7420756
which claims benefit of 60/471,872 05/20/2003"

but should appear as

--This application is a CON of 13/776,247 02/25/2013 PAT 8562157
which is a CON of 13/776,091 02/25/2013
which is a CON of 13/590,854 08/21/2012 PAT 8550642
which is a DIV of 13/336,018 12/23/2011 PAT 8267534
which is a CON of 12/911,274 10/25/2010 PAT 8128243
which is a CON of 12/851,045 08/05/2010 PAT 7934843
which is a CON of 12/197,666 08/25/2008 PAT 7842154
which is a CON of 10/709,434 05/05/2004 PAT 7420756
which claims benefit of 60/471,872 05/20/2003--

A copy of the filing receipt with the correction noted thereon is attached. Also attached is a copy of a Supplemental Application Data Sheet.

Inventor : Niall R. Lynam
Serial No. : 14/054,004
Page No. : 2

The remaining information on the filing receipt appears to be correct. However, correction of the Domestic Priority section as noted above is respectfully requested.

Respectfully submitted,

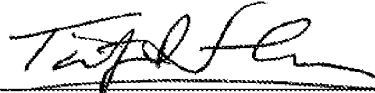

Date: November 12, 2013

Timothy A. Flory
Registration No. 42 540
Gardner, Linn, Burkhart & Flory, LLP
2851 Charlevoix Drive, S.E., Suite 207
Grand Rapids, Michigan 49546
(616) 975-5500

Under the Paperwork Reduction Act of 1995, no persons are required to respond to a collection of information unless it contains a valid OMB control number.

Application Data Sheet 37 CFR 1.76		Attorney Docket Number	DON09 P-2194
		Application Number	14/054,004
Title of Invention	EXTENDED FIELD OF VIEW EXTERIOR MIRROR ELEMENT FOR VEHICLE		
The application data sheet is part of the provisional or nonprovisional application for which it is being submitted. The following form contains the bibliographic data arranged in a format specified by the United States Patent and Trademark Office as outlined in 37 CFR 1.76. This document may be completed electronically and submitted to the Office in electronic format using the Electronic Filing System (EFS) or the document may be printed and included in a paper filed application.			

Secrecy Order 37 CFR 5.2

<input type="checkbox"/>	Portions or all of the application associated with this Application Data Sheet may fall under a Secrecy Order pursuant to 37 CFR 5.2 (Paper filers only. Applications that fall under Secrecy Order may not be filed electronically.)
--------------------------	---

Inventor Information:

Inventor 1					<input type="button" value="Remove"/>
Legal Name					
Prefix	Given Name	Middle Name	Family Name	Suffix	
	Niall	R.	Lynam		
Residence Information (Select One) <input checked="" type="radio"/> US Residency <input type="radio"/> Non US Residency <input type="radio"/> Active US Military Service					
City	Holland	State/Province	MI	Country of Residence	US
Mailing Address of Inventor:					
Address 1	281 Norwood Avenue				
Address 2					
City	Holland	State/Province	MI		
Postal Code	49424	Country	US		
All Inventors Must Be Listed - Additional Inventor Information blocks may be generated within this form by selecting the Add button. <input type="button" value="Add"/>					

Correspondence Information:

Enter either Customer Number or complete the Correspondence Information section below. For further information see 37 CFR 1.33(a).			
<input type="checkbox"/> An Address is being provided for the correspondence information of this application.			
Customer Number	15671		
Email Address	flory@glbf.com	<input type="button" value="Add Email"/>	<input type="button" value="Remove Email"/>

Application Information:

Title of the Invention	EXTENDED FIELD OF VIEW EXTERIOR MIRROR ELEMENT FOR VEHICLE		
Attorney Docket Number	DON09 P-2194	Small Entity Status Claimed	<input type="checkbox"/>
Application Type	Nonprovisional		
Subject Matter	Utility		
Total Number of Drawing Sheets (if any)	19	Suggested Figure for Publication (if any)	

Application Data Sheet 37 CFR 1.76		Attorney Docket Number	DON09 P-2194
		Application Number	14/054,004
Title of Invention	EXTENDED FIELD OF VIEW EXTERIOR MIRROR ELEMENT FOR VEHICLE		

Publication Information:

<input type="checkbox"/>	Request Early Publication (Fee required at time of Request 37 CFR 1.219)
<input type="checkbox"/>	Request Not to Publish. I hereby request that the attached application not be published under 35 U.S.C. 122(b) and certify that the invention disclosed in the attached application has not and will not be the subject of an application filed in another country, or under a multilateral international agreement, that requires publication at eighteen months after filing.

Representative Information:

Representative information should be provided for all practitioners having a power of attorney in the application. Providing this information in the Application Data Sheet does not constitute a power of attorney in the application (see 37 CFR 1.32). Either enter Customer Number or complete the Representative Name section below. If both sections are completed the customer number will be used for the Representative Information during processing.			
Please Select One:			
<input checked="" type="radio"/>	Customer Number	<input type="radio"/>	US Patent Practitioner
<input type="radio"/>	Limited Recognition (37 CFR 11.9)		
Customer Number	15671		

Domestic Benefit/National Stage Information:

This section allows for the applicant to either claim benefit under 35 U.S.C. 119(e), 120, 121, or 365(c) or indicate National Stage entry from a PCT application. Providing this information in the application data sheet constitutes the specific reference required by 35 U.S.C. 119(e) or 120, and 37 CFR 1.78.					
Prior Application Status	Pending		Remove		
Application Number	Continuity Type	Prior Application Number	Filing Date (YYYY-MM-DD)		
14/054,004	Continuation of	13776247	2013-02-25		
Prior Application Status	Pending		Remove		
Application Number	Continuity Type	Prior Application Number	Filing Date (YYYY-MM-DD)		
14/054,004	Continuation of	13776091	2013-02-25		
Prior Application Status	Patented		Remove		
Application Number	Continuity Type	Prior Application Number	Filing Date (YYYY-MM-DD)	Patent Number	Issue Date (YYYY-MM-DD)
13776091	Continuation of	13590854	2012-08-21	8550642	2013-10-08
Prior Application Status	Patented		Remove		
Application Number	Continuity Type	Prior Application Number	Filing Date (YYYY-MM-DD)	Patent Number	Issue Date (YYYY-MM-DD)
13590854	Division of	13336018	2011-12-23	8267534	2012-09-18
Prior Application Status	Patented		Remove		

Under the Paperwork Reduction Act of 1995, no persons are required to respond to a collection of information unless it contains a valid OMB control number.

Application Data Sheet 37 CFR 1.76		Attorney Docket Number	DON09 P-2194
		Application Number	14/054,004
Title of Invention	EXTENDED FIELD OF VIEW EXTERIOR MIRROR ELEMENT FOR VEHICLE		

Application Number	Continuity Type	Prior Application Number	Filing Date (YYYY-MM-DD)	Patent Number	Issue Date (YYYY-MM-DD)
13336018	Continuation of	12911274	2010-10-25	8128243	2010-03-06
Prior Application Status		Patented		Remove	
Application Number	Continuity Type	Prior Application Number	Filing Date (YYYY-MM-DD)	Patent Number	Issue Date (YYYY-MM-DD)
12911274	Continuation of	12851045	2010-08-05	7934843	2011-05-03
Prior Application Status		Patented		Remove	
Application Number	Continuity Type	Prior Application Number	Filing Date (YYYY-MM-DD)	Patent Number	Issue Date (YYYY-MM-DD)
12851045	Continuation of	12197666	2008-08-25	7842154	2010-11-30
Prior Application Status		Patented		Remove	
Application Number	Continuity Type	Prior Application Number	Filing Date (YYYY-MM-DD)	Patent Number	Issue Date (YYYY-MM-DD)
12197666	Division of	10709434	2004-05-05	7420756	2008-09-02
Prior Application Status		Expired		Remove	
Application Number	Continuity Type	Prior Application Number	Filing Date (YYYY-MM-DD)		
10709434	non provisional of	60471872	2003-05-20		
Additional Domestic Benefit/National Stage Data may be generated within this form by selecting the Add button.					

Foreign Priority Information:

This section allows for the applicant to claim priority to a foreign application. Providing this information in the application data sheet constitutes the claim for priority as required by 35 U.S.C. 119(b) and 37 CFR 1.55(d). When priority is claimed to a foreign application that is eligible for retrieval under the priority document exchange program (PDX) ⁱ the information will be used by the Office to automatically attempt retrieval pursuant to 37 CFR 1.55(h)(1) and (2). Under the PDX program, applicant bears the ultimate responsibility for ensuring that a copy of the foreign application is received by the Office from the participating foreign intellectual property office, or a certified copy of the foreign priority application is filed, within the time period specified in 37 CFR 1.55(g)(1).			
Remove			
Application Number	Country ^j	Filing Date (YYYY-MM-DD)	Access Code ^k (if applicable)
Additional Foreign Priority Data may be generated within this form by selecting the Add button.			

Under the Paperwork Reduction Act of 1995, no persons are required to respond to a collection of information unless it contains a valid OMB control number.

Application Data Sheet 37 CFR 1.76	Attorney Docket Number	DON09 P-2194
	Application Number	14/054,004
Title of Invention	EXTENDED FIELD OF VIEW EXTERIOR MIRROR ELEMENT FOR VEHICLE	

Statement under 37 CFR 1.55 or 1.78 for AIA (First Inventor to File) Transition Applications

This application (1) claims priority to or the benefit of an application filed before March 16, 2013 and (2) also contains, or contained at any time, a claim to a claimed invention that has an effective filing date on or after March 16, 2013.

Authorization to Permit Access:

Authorization to Permit Access to the Instant Application by the Participating Offices

If checked, the undersigned hereby grants the USPTO authority to provide the European Patent Office (EPO), the Japan Patent Office (JPO), the Korean Intellectual Property Office (KIPO), the World Intellectual Property Office (WIPO), and any other intellectual property offices in which a foreign application claiming priority to the instant patent application is filed access to the instant patent application. See 37 CFR 1.14(c) and (h). This box should not be checked if the applicant does not wish the EPO, JPO, KIPO, WIPO, or other intellectual property office in which a foreign application claiming priority to the instant patent application is filed to have access to the instant patent application.

In accordance with 37 CFR 1.14(h)(3), access will be provided to a copy of the instant patent application with respect to: 1) the instant patent application-as-filed; 2) any foreign application to which the instant patent application claims priority under 35 U.S.C. 119(a)-(d) if a copy of the foreign application that satisfies the certified copy requirement of 37 CFR 1.55 has been filed in the instant patent application; and 3) any U.S. application-as-filed from which benefit is sought in the instant patent application.

In accordance with 37 CFR 1.14(c), access may be provided to information concerning the date of filing this Authorization.

Applicant Information:

Providing assignment information in this section does not substitute for compliance with any requirement of part 3 of Title 37 of CFR to have an assignment recorded by the Office.

Applicant 1

If the applicant is the inventor (or the remaining joint inventor or inventors under 37 CFR 1.45), this section should not be completed. The information to be provided in this section is the name and address of the legal representative who is the applicant under 37 CFR 1.43; or the name and address of the assignee, person to whom the inventor is under an obligation to assign the invention, or person who otherwise shows sufficient proprietary interest in the matter who is the applicant under 37 CFR 1.46. If the applicant is an applicant under 37 CFR 1.46 (assignee, person to whom the inventor is obligated to assign, or person who otherwise shows sufficient proprietary interest) together with one or more joint inventors, then the joint inventor or inventors who are also the applicant should be identified in this section.

Assignee Legal Representative under 35 U.S.C. 117 Joint Inventor

Person to whom the inventor is obligated to assign. Person who shows sufficient proprietary interest

Under the Paperwork Reduction Act of 1995, no persons are required to respond to a collection of information unless it contains a valid OMB control number.

Application Data Sheet 37 CFR 1.76		Attorney Docket Number	DON09 P-2194	
		Application Number	14/054,004	
Title of Invention	EXTENDED FIELD OF VIEW EXTERIOR MIRROR ELEMENT FOR VEHICLE			

If applicant is the legal representative, indicate the authority to file the patent application, the inventor is:

--	--

Name of the Deceased or Legally Incapacitated Inventor :

If the Applicant is an Organization check here.

Organization Name	Donnelly Corporation
-------------------	----------------------

Mailing Address Information For Applicant:

Address 1	49 W. Third Street		
Address 2			
City	Holland	State/Province	MI
Country	US	Postal Code	49424
Phone Number		Fax Number	
Email Address			

Additional Applicant Data may be generated within this form by selecting the Add button.

Non-Applicant Assignee Information:

Providing assignment information in this section does not substitute for compliance with any requirement of part 3 of Title 37 of CFR to have an assignment recorded by the Office.

Assignee 1				
Complete this section only if non-applicant assignee information is desired to be included on the patent application publication in accordance with 37 CFR 1.215(b). Do not include in this section an applicant under 37 CFR 1.46 (assignee, person to whom the inventor is obligated to assign, or person who otherwise shows sufficient proprietary interest), as the patent application publication will include the name of the applicant(s).				
If the Assignee is an Organization check here. <input type="checkbox"/>				
Prefix	Given Name	Middle Name	Family Name	Suffix

Under the Paperwork Reduction Act of 1995, no persons are required to respond to a collection of information unless it contains a valid OMB control number.

Application Data Sheet 37 CFR 1.76		Attorney Docket Number	DON09 P-2194
		Application Number	14/054,004
Title of Invention	EXTENDED FIELD OF VIEW EXTERIOR MIRROR ELEMENT FOR VEHICLE		

Mailing Address Information For Non-Applicant Assignee:			
Address 1			
Address 2			
City		State/Province	
Country ⁱ		Postal Code	
Phone Number		Fax Number	
Email Address			
Additional Assignee Data may be generated within this form by selecting the Add button.			

Signature:

NOTE: This form must be signed in accordance with 37 CFR 1.33. See 37 CFR 1.4 for signature requirements and certifications.			
Signature	/taf/	Date (YYYY-MM-DD)	2013-11-12
First Name	Timothy	Last Name	Flory
		Registration Number	42540
Additional Signature may be generated within this form by selecting the Add button.			

This collection of information is required by 37 CFR 1.76. The information is required to obtain or retain a benefit by the public which is to file (and by the USPTO to process) an application. Confidentiality is governed by 35 U.S.C. 122 and 37 CFR 1.14. This collection is estimated to take 23 minutes to complete, including gathering, preparing, and submitting the completed application data sheet form to the USPTO. Time will vary depending upon the individual case. Any comments on the amount of time you require to complete this form and/or suggestions for reducing this burden, should be sent to the Chief Information Officer, U.S. Patent and Trademark Office, U.S. Department of Commerce, P.O. Box 1450, Alexandria, VA 22313-1450. DO NOT SEND FEES OR COMPLETED FORMS TO THIS ADDRESS. **SEND TO: Commissioner for Patents, P.O. Box 1450, Alexandria, VA 22313-1450.**



UNITED STATES PATENT AND TRADEMARK OFFICE

UNITED STATES DEPARTMENT OF COMMERCE
United States Patent and Trademark Office
Address: COMMISSIONER FOR PATENTS
P.O. Box 1450
Alexandria, Virginia 22313-1450
www.uspto.gov

Table with 7 columns: APPLICATION NUMBER, FILING or 371(c) DATE, GRP ART UNIT, FIL FEE REC'D, ATTY. DOCKET NO, TOT CLAIMS, IND CLAIMS. Row 1: 14/054,004, 10/15/2013, 2872, 1600, DON09 P-2194, 20, 3

CONFIRMATION NO. 4390

15671
Gardner, Linn, Burkhardt & Flory, LLP
2851 Charlevoix Dr., SE, Suite 207
Grand Rapids, MI 49546

FILING RECEIPT



Date Mailed: 11/04/2013

Receipt is acknowledged of this non-provisional patent application. The application will be taken up for examination in due course. Applicant will be notified as to the results of the examination. Any correspondence concerning the application must include the following identification information: the U.S. APPLICATION NUMBER, FILING DATE, NAME OF APPLICANT, and TITLE OF INVENTION. Fees transmitted by check or draft are subject to collection. Please verify the accuracy of the data presented on this receipt. If an error is noted on this Filing Receipt, please submit a written request for a Filing Receipt Correction. Please provide a copy of this Filing Receipt with the changes noted thereon. If you received a "Notice to File Missing Parts" for this application, please submit any corrections to this Filing Receipt with your reply to the Notice. When the USPTO processes the reply to the Notice, the USPTO will generate another Filing Receipt incorporating the requested corrections

Inventor(s)

Niall R. Lynam, Holland, MI;

Applicant(s)

Donnelly Corporation, Holland, MI

Assignment For Published Patent Application

Donnelly Corporation, Holland, MI

Power of Attorney: The patent practitioners associated with Customer Number 15671

Domestic Priority data as claimed by applicant

This application is a CON of 13/776,247 02/25/2013 PAT 8562157
and is a CON of 13/776,091 02/25/2013
which is a CON of 13/590,854 08/21/2012 PAT 8550642
which is a CON of 12/911,274 10/25/2010 PAT 8128243
which is a CON of 12/851,045 08/05/2010 PAT 7934843
which is a CON of 12/197,666 08/25/2008 PAT 7842154
which is a DIV of 10/709,434 05/05/2004 PAT 7420756
which claims benefit of 60/471,872 05/20/2003

Foreign Applications for which priority is claimed (You may be eligible to benefit from the Patent Prosecution Highway program at the USPTO. Please see http://www.uspto.gov for more information.) - None.

Foreign application information must be provided in an Application Data Sheet in order to constitute a claim to foreign priority. See 37 CFR 1.55 and 1.76.

If Required, Foreign Filing License Granted: 10/28/2013

The country code and number of your priority application, to be used for filing abroad under the Paris Convention, is **US 14/054,004**

Projected Publication Date: 02/13/2014

Non-Publication Request: No

Early Publication Request: No
Title

EXTENDED FIELD OF VIEW EXTERIOR MIRROR ELEMENT FOR VEHICLE

Preliminary Class

359

Statement under 37 CFR 1.55 or 1.78 for AIA (First Inventor to File) Transition Applications: No

PROTECTING YOUR INVENTION OUTSIDE THE UNITED STATES

Since the rights granted by a U.S. patent extend only throughout the territory of the United States and have no effect in a foreign country, an inventor who wishes patent protection in another country must apply for a patent in a specific country or in regional patent offices. Applicants may wish to consider the filing of an international application under the Patent Cooperation Treaty (PCT). An international (PCT) application generally has the same effect as a regular national patent application in each PCT-member country. The PCT process **simplifies** the filing of patent applications on the same invention in member countries, but **does not result** in a grant of "an international patent" and does not eliminate the need of applicants to file additional documents and fees in countries where patent protection is desired.

Almost every country has its own patent law, and a person desiring a patent in a particular country must make an application for patent in that country in accordance with its particular laws. Since the laws of many countries differ in various respects from the patent law of the United States, applicants are advised to seek guidance from specific foreign countries to ensure that patent rights are not lost prematurely.

Applicants also are advised that in the case of inventions made in the United States, the Director of the USPTO must issue a license before applicants can apply for a patent in a foreign country. The filing of a U.S. patent application serves as a request for a foreign filing license. The application's filing receipt contains further information and guidance as to the status of applicant's license for foreign filing.

Applicants may wish to consult the USPTO booklet, "General Information Concerning Patents" (specifically, the section entitled "Treaties and Foreign Patents") for more information on timeframes and deadlines for filing foreign patent applications. The guide is available either by contacting the USPTO Contact Center at 800-786-9199, or it can be viewed on the USPTO website at <http://www.uspto.gov/web/offices/pac/doc/general/index.html>.

For information on preventing theft of your intellectual property (patents, trademarks and copyrights), you may wish to consult the U.S. Government website, <http://www.stopfakes.gov>. Part of a Department of Commerce initiative, this website includes self-help "toolkits" giving innovators guidance on how to protect intellectual property in specific countries such as China, Korea and Mexico. For questions regarding patent enforcement issues, applicants may call the U.S. Government hotline at 1-866-999-HALT (1-866-999-4258).

LICENSE FOR FOREIGN FILING UNDER
Title 35, United States Code, Section 184
Title 37, Code of Federal Regulations, 5.11 & 5.15

GRANTED

The applicant has been granted a license under 35 U.S.C. 184, if the phrase "IF REQUIRED, FOREIGN FILING LICENSE GRANTED" followed by a date appears on this form. Such licenses are issued in all applications where the conditions for issuance of a license have been met, regardless of whether or not a license may be required as set forth in 37 CFR 5.15. The scope and limitations of this license are set forth in 37 CFR 5.15(a) unless an earlier license has been issued under 37 CFR 5.15(b). The license is subject to revocation upon written notification. The date indicated is the effective date of the license, unless an earlier license of similar scope has been granted under 37 CFR 5.13 or 5.14.

This license is to be retained by the licensee and may be used at any time on or after the effective date thereof unless it is revoked. This license is automatically transferred to any related applications(s) filed under 37 CFR 1.53(d). This license is not retroactive.

The grant of a license does not in any way lessen the responsibility of a licensee for the security of the subject matter as imposed by any Government contract or the provisions of existing laws relating to espionage and the national security or the export of technical data. Licensees should apprise themselves of current regulations especially with respect to certain countries, of other agencies, particularly the Office of Defense Trade Controls, Department of State (with respect to Arms, Munitions and Implements of War (22 CFR 121-128)); the Bureau of Industry and Security, Department of Commerce (15 CFR parts 730-774); the Office of Foreign Assets Control, Department of Treasury (31 CFR Parts 500+) and the Department of Energy.

NOT GRANTED

No license under 35 U.S.C. 184 has been granted at this time, if the phrase "IF REQUIRED, FOREIGN FILING LICENSE GRANTED" DOES NOT appear on this form. Applicant may still petition for a license under 37 CFR 5.12, if a license is desired before the expiration of 6 months from the filing date of the application. If 6 months has lapsed from the filing date of this application and the licensee has not received any indication of a secrecy order under 35 U.S.C. 181, the licensee may foreign file the application pursuant to 37 CFR 5.15(b).

SelectUSA

The United States represents the largest, most dynamic marketplace in the world and is an unparalleled location for business investment, innovation, and commercialization of new technologies. The U.S. offers tremendous resources and advantages for those who invest and manufacture goods here. Through SelectUSA, our nation works to promote and facilitate business investment. SelectUSA provides information assistance to the international investor community; serves as an ombudsman for existing and potential investors; advocates on behalf of U.S. cities, states, and regions competing for global investment; and counsels U.S. economic development organizations on investment attraction best practices. To learn more about why the United States is the best country in the world to develop technology, manufacture products, deliver services, and grow your business, visit <http://www.SelectUSA.gov> or call +1-202-482-6800.

Electronic Acknowledgement Receipt

EFS ID:	17367546
Application Number:	14054004
International Application Number:	
Confirmation Number:	4390
Title of Invention:	EXTENDED FIELD OF VIEW EXTERIOR MIRROR ELEMENT FOR VEHICLE
First Named Inventor/Applicant Name:	Niall R. Lynam
Customer Number:	15671
Filer:	Timothy A. Flory/Amanda Sytsma
Filer Authorized By:	Timothy A. Flory
Attorney Docket Number:	DON09 P-2194
Receipt Date:	12-NOV-2013
Filing Date:	15-OCT-2013
Time Stamp:	11:39:38
Application Type:	Utility under 35 USC 111(a)

Payment information:

Submitted with Payment	no
------------------------	----

File Listing:

Document Number	Document Description	File Name	File Size(Bytes)/ Message Digest	Multi Part /.zip	Pages (if appl.)
1	Transmittal Letter	TransmittalForm.pdf	120233 <small>8cbd98daee9f35ec5dd8fa0f0d016a4d562e8e08</small>	no	1

Warnings:

Information:

2	Request for Corrected Filing Receipt	RequestforCorrectionofFilingReceipt.pdf	15761 23686d55d2fa056e2f21b638b81f22d96abe0532	no	2
Warnings:					
Information:					
3	Application Data Sheet	SupplementalApplicationDataSheet.pdf	117245 f25b5726ad69885f5f3666fb20664dd40a83571a	no	6
Warnings:					
Information:					
This is not an USPTO supplied ADS fillable form					
4	Miscellaneous Incoming Letter	FilingReceiptwithCorrectionNoted.pdf	345543 f7701cd0fa468ea6b6e29e427d9b44f511e5edb4	no	3
Warnings:					
Information:					
Total Files Size (in bytes):			598782		
<p>This Acknowledgement Receipt evidences receipt on the noted date by the USPTO of the indicated documents, characterized by the applicant, and including page counts, where applicable. It serves as evidence of receipt similar to a Post Card, as described in MPEP 503.</p> <p><u>New Applications Under 35 U.S.C. 111</u> If a new application is being filed and the application includes the necessary components for a filing date (see 37 CFR 1.53(b)-(d) and MPEP 506), a Filing Receipt (37 CFR 1.54) will be issued in due course and the date shown on this Acknowledgement Receipt will establish the filing date of the application.</p> <p><u>National Stage of an International Application under 35 U.S.C. 371</u> If a timely submission to enter the national stage of an international application is compliant with the conditions of 35 U.S.C. 371 and other applicable requirements a Form PCT/DO/EO/903 indicating acceptance of the application as a national stage submission under 35 U.S.C. 371 will be issued in addition to the Filing Receipt, in due course.</p> <p><u>New International Application Filed with the USPTO as a Receiving Office</u> If a new international application is being filed and the international application includes the necessary components for an international filing date (see PCT Article 11 and MPEP 1810), a Notification of the International Application Number and of the International Filing Date (Form PCT/RO/105) will be issued in due course, subject to prescriptions concerning national security, and the date shown on this Acknowledgement Receipt will establish the international filing date of the application.</p>					

Under the Paperwork Reduction Act of 1995, no persons are required to respond to a collection of information unless it displays a valid OMB control number.

<h2>TRANSMITTAL FORM</h2> <p><i>(to be used for all correspondence after initial filing)</i></p>	Application Number	14/054,004
	Filing Date	October 15, 2013
	First Named Inventor	Niall R. Lynam
	Art Unit	2872
	Examiner Name	
Total Number of Pages in This Submission	Attorney Docket Number	DON09 P-2194

ENCLOSURES (Check all that apply)		
<input type="checkbox"/> Fee Transmittal Form	<input type="checkbox"/> Drawing(s)	<input type="checkbox"/> After Allowance Communication to TC
<input type="checkbox"/> Fee Attached	<input type="checkbox"/> Licensing-related Papers	<input type="checkbox"/> Appeal Communication to Board of Appeals and Interferences
<input type="checkbox"/> Amendment/Reply	<input type="checkbox"/> Petition	<input type="checkbox"/> Appeal Communication to TC (Appeal Notice, Brief, Reply Brief)
<input type="checkbox"/> After Final	<input type="checkbox"/> Petition to Convert to a Provisional Application	<input type="checkbox"/> Proprietary Information
<input type="checkbox"/> Affidavits/declaration(s)	<input type="checkbox"/> Power of Attorney, Revocation	<input type="checkbox"/> Status Letter
<input type="checkbox"/> Extension of Time Request	<input type="checkbox"/> Change of Correspondence Address	<input checked="" type="checkbox"/> Other Enclosure(s) (please identify below):
<input type="checkbox"/> Express Abandonment Request	<input type="checkbox"/> Terminal Disclaimer	-Request for Corrected Filing Receipt
<input type="checkbox"/> Information Disclosure Statement	<input type="checkbox"/> Request for Refund	-Filing Receipt with Correction Noted
<input type="checkbox"/> Certified Copy of Priority Document(s)	<input type="checkbox"/> CD, Number of CD(s) _____	
<input type="checkbox"/> Reply to Missing Parts/ Incomplete Application	<input type="checkbox"/> Landscape Table on CD	
<input type="checkbox"/> Reply to Missing Parts under 37 CFR 1.52 or 1.53	Remarks	

SIGNATURE OF APPLICANT, ATTORNEY, OR AGENT			
Firm Name	GARDNER, LINN, BURKHART & FLORY, LLP		
Signature	/taf/		
Printed name	Timothy A. Flory		
Date	November 12, 2013	Reg. No.	42540

CERTIFICATE OF TRANSMISSION/MAILING			
I hereby certify that this correspondence is being facsimile transmitted to the USPTO or deposited with the United States Postal Service with sufficient postage as first class mail in an envelope addressed to: Commissioner for Patents, P.O. Box 1450, Alexandria, VA 22313-1450 on the date shown below:			
Signature	/ars/		
Typed or printed name	Amanda R. Sytsma	Date	November 12, 2013

This collection of information is required by 37 CFR 1.5. The information is required to obtain or retain a benefit by the public which is to file (and by the USPTO to process) an application. Confidentiality is governed by 35 U.S.C. 122 and 37 CFR 1.11 and 1.14. This collection is estimated to 2 hours to complete, including gathering, preparing, and submitting the completed application form to the USPTO. Time will vary depending upon the individual case. Any comments on the amount of time you require to complete this form and/or suggestions for reducing this burden, should be sent to the Chief Information Officer, U.S. Patent and Trademark Office, U.S. Department of Commerce, P.O. Box 1450, Alexandria, VA 22313-1450. DO NOT SEND FEES OR COMPLETED FORMS TO THIS ADDRESS. SEND TO: **Commissioner for Patents, P.O. Box 1450, Alexandria, VA 22313-1450.**

If you need assistance in completing the form, call 1-800-PTO-9199 and select option 2.

Under the Paperwork Reduction Act of 1995, no persons are required to respond to a collection of information unless it contains a valid OMB control number.

Substitute for form 1449/PTO				Complete if Known	
				Application Number	14/054,004
INFORMATION DISCLOSURE STATEMENT BY APPLICANT <i>(Use as many sheets as necessary)</i>				Filing Date	October 15, 2013
				First Named Inventor	Niall R. Lynam
				Art Unit	2853
				Examiner Name	Alessandro V. Amari
				Attorney Docket Number	DON09 P-2194
				Sheet	1

U. S. PATENT DOCUMENTS

Examiner Initials*	Cite No. ¹	Document Number	Publication Date MM-DD-YYYY	Name of Patentee or Applicant of Cited Document	Pages, Columns, Lines, Where Relevant Passages or Relevant Figures Appear
		Number-Kind Code ² (If Known)			
		8,562,157	2013-10-22	Lynam	
		8,267,534	2012-09-18	Lynam	
		7,934,843	2011-05-03	Lynam	
		7,857,469	2010-12-28	Sinelli et al.	
		7,636,188	2009-12-22	Baur et al.	
		7,626,749	2009-12-01	Baur et al.	
		7,581,859	2009-09-01	Lynam	
		7,526,103	2009-04-28	Schofield et al.	
		7,492,281	2009-02-17	Lynam et al.	
		7,423,522	2008-09-09	O'Brien et al.	
		7,420,756	2008-09-02	Lynam	
		7,400,435	2008-07-15	Byers et al.	
		7,391,563	2008-06-24	McCabe et al.	
		7,377,675	2008-05-27	Pastrick et al.	
		7,370,983	2008-05-13	DeWind et al.	
		7,345,680	2008-03-18	David	
		7,339,149	2008-03-04	Schofield et al.	
		7,338,177	2008-03-04	Lynam	
		7,289,037	2007-10-30	Uken et al.	
		7,274,501	2007-09-25	McCabe et al.	
		7,267,448	2007-09-11	Schmidt et al.	
		7,255,451	2007-08-14	McCabe et al.	
		7,249,860	2007-07-31	Kulas et al.	
		7,195,381	2007-03-27	Lynam et al.	
		7,184,190	2007-02-27	McCabe et al.	
		7,168,830	2007-01-30	Pastrick et al.	
		7,167,294	2007-01-23	Lynam et al.	
		7,126,456	2006-10-24	Boddy et al.	
		7,106,392	2006-09-12	You	
		7,097,312	2006-08-29	Platzer, Jr.	
		7,038,577	2006-05-02	Pawlicki et al.	
		7,025,469	2006-04-11	Manfre' et al.	
		7,005,974	2006-02-28	McMahon et al.	
		7,001,032	2006-02-21	Lo	

Examiner Signature		Date Considered	
-----------------------	--	--------------------	--

*EXAMINER: Initial if reference considered, whether or not citation is in conformance with MPEP 609. Draw line through citation if not in conformance and not considered. Include copy of this form with next communication to applicant. ¹ Applicant's unique citation designation number (optional). ² See Kinds Codes of USPTO Patent Documents at www.uspto.gov or MPEP 901.04. ³ Enter Office that issued the document, by the two-letter code (WIPO Standard ST.3). ⁴ For Japanese patent documents, the indication of the year of the reign of the Emperor must precede the serial number of the patent document. ⁵ Kind of document by the appropriate symbols as indicated on the document under WIPO Standard ST.16 if possible. ⁶ Applicant is to place a check mark here if English language Translation is attached.

This collection of information is required by 37 CFR 1.97 and 1.98. The information is required to obtain or retain a benefit by the public which is to file (and by the USPTO to process) an application. Confidentiality is governed by 35 U.S.C. 122 and 37 CFR 1.14. This collection is estimated to take 2 hours to complete, including gathering, preparing, and submitting the completed application form to the USPTO. Time will vary depending upon the individual case. Any comments on the amount of time you require to complete this form and/or suggestions for reducing this burden, should be sent to the Chief Information Officer, U.S. Patent and Trademark Office, P.O. Box 1450, Alexandria, VA 22313-1450. DO NOT SEND FEES OR COMPLETED FORMS TO THIS ADDRESS. SEND TO: Commissioner for Patents, P.O. Box 1450, Alexandria, VA 22313-1450.

Under the Paperwork Reduction Act of 1995, no persons are required to respond to a collection of information unless it contains a valid OMB control number.

Substitute for form 1449/PTO				Complete if Known	
				Application Number	14/054,004
INFORMATION DISCLOSURE STATEMENT BY APPLICANT <i>(Use as many sheets as necessary)</i>				Filing Date	October 15, 2013
				First Named Inventor	Niall R. Lynam
				Art Unit	2853
				Examiner Name	Alessandro V. Amari
				Attorney Docket Number	DON09 P-2194
				Sheet	2

U. S. PATENT DOCUMENTS					
Examiner Initials*	Cite No. ¹	Document Number	Publication Date MM-DD-YYYY	Name of Patentee or Applicant of Cited Document	Pages, Columns, Lines, Where Relevant Passages or Relevant Figures Appear
		Number-Kind Code ² (If Known)			

		6,979,090	2005-12-27	Wnuk	
		6,932,483	2005-08-23	Strumolo et al.	
		6,919,796	2005-07-19	Boddy et al.	
		6,882,287	2005-04-19	Schofield	
		6,831,268	2004-12-14	Bechtel et al.	
		6,824,281	2004-11-30	Schofield et al.	
		6,757,109	2004-06-29	Bos	
		6,742,904	2004-06-01	Bechtel et al.	
		6,737,629	2004-05-18	Nixon et al.	
		6,731,205	2004-05-04	Schofield et al.	
		6,719,215	2004-04-13	Drouillard	
		6,717,712	2004-04-06	Lynam et al.	
		6,717,610	2004-04-06	Bos et al.	
		6,709,119	2004-03-23	Gillich et al.	
		6,690,268	2004-02-10	Schofield et al.	
		6,669,109	2003-12-30	Ivanov et al.	
		6,648,477	2003-11-18	Hutzel et al.	
		6,642,851	2003-11-04	DeLine et al.	
		6,627,918	2003-09-30	Getz et al.	
		6,615,438	2003-09-09	Franco	
		6,595,649	2003-07-22	Hoekstra et al.	
		6,582,109	2003-06-24	Miller	
		6,537,138	2003-03-25	Ohmori et al.	
		6,522,451	2003-02-18	Lynam	
		6,512,624	2003-01-28	Tonar et al.	
		6,511,192	2003-01-28	Henion et al.	
		6,501,387	2002-12-31	Skiver et al.	
		6,498,620	2002-12-24	Schofield et al.	
		6,472,979	2002-10-29	Schofield et al.	
		6,449,082	2002-09-10	Agrawal et al.	
		6,445,287	2002-09-03	Schofield et al.	
		6,441,964	2002-08-27	Chu et al.	
		6,428,172	2002-08-06	Hutzel et al.	
		6,420,036	2002-07-16	Varaprasad et al.	

Examiner Signature		Date Considered	
--------------------	--	-----------------	--

*EXAMINER: Initial if reference considered, whether or not citation is in conformance with MPEP 609. Draw line through citation if not in conformance and not considered. Include copy of this form with next communication to applicant. ¹ Applicant's unique citation designation number (optional). ² See Kinds Codes of USPTO Patent Documents at www.uspto.gov or MPEP 901.04. ³ Enter Office that issued the document, by the two-letter code (WIPO Standard ST.3). ⁴ For Japanese patent documents, the indication of the year of the reign of the Emperor must precede the serial number of the patent document. ⁵ Kind of document by the appropriate symbols as indicated on the document under WIPO Standard ST.16 if possible. ⁶ Applicant is to place a check mark here if English language Translation is attached.

This collection of information is required by 37 CFR 1.97 and 1.98. The information is required to obtain or retain a benefit by the public which is to file (and by the USPTO to process) an application. Confidentiality is governed by 35 U.S.C. 122 and 37 CFR 1.14. This collection is estimated to take 2 hours to complete, including gathering, preparing, and submitting the completed application form to the USPTO. Time will vary depending upon the individual case. Any comments on the amount of time you require to complete this form and/or suggestions for reducing this burden, should be sent to the Chief Information Officer, U.S. Patent and Trademark Office, P.O. Box 1450, Alexandria, VA 22313-1450. DO NOT SEND FEES OR COMPLETED FORMS TO THIS ADDRESS. SEND TO: Commissioner for Patents, P.O. Box 1450, Alexandria, VA 22313-1450.

Under the Paperwork Reduction Act of 1995, no persons are required to respond to a collection of information unless it contains a valid OMB control number.

Substitute for form 1449/PTO				Complete if Known	
INFORMATION DISCLOSURE STATEMENT BY APPLICANT <i>(Use as many sheets as necessary)</i>				Application Number	14/054,004
				Filing Date	October 15, 2013
				First Named Inventor	Niall R. Lynam
				Art Unit	2853
				Examiner Name	Alessandro V. Amari
				Attorney Docket Number	DON09 P-2194
Sheet	3	of	13		

U. S. PATENT DOCUMENTS

Examiner Initials*	Cite No. ¹	Document Number	Publication Date MM-DD-YYYY	Name of Patentee or Applicant of Cited Document	Pages, Columns, Lines, Where Relevant Passages or Relevant Figures Appear
		Number-Kind Code ² (If Known)			
		6,409,354	2002-06-25	Richard	
		6,398,377	2002-06-04	Chou	
		6,396,397	2002-05-28	Bos et al.	
		6,390,632	2002-05-21	Palathingal	
		6,356,376	2002-03-12	Tonar et al.	
		6,343,402	2002-02-05	Smith et al.	
		6,341,523	2002-01-29	Lynam	
		6,329,925	2001-12-11	Skiver et al.	
		6,320,282	2001-11-20	Caldwell	
		6,318,870	2001-11-20	Spooner et al.	
		6,315,419	2001-11-13	Platzer, Jr.	
		6,310,611	2001-10-30	Caldwell	
		6,294,989	2001-09-25	Schofield et al.	
		6,286,965	2001-09-11	Caskey et al.	
		6,276,821	2001-08-21	Pastrick et al.	
		6,270,225	2001-08-07	Goolsby	
		6,260,608	2001-07-17	Kim	
		6,257,746	2001-07-10	Todd et al.	
		6,250,148	2001-06-26	Lynam	
		6,245,262	2001-06-12	Varaprasad et al.	
		6,227,689	2001-05-08	Miller	
		6,207,083	2001-03-27	Varaprasad et al.	
		6,201,642	2001-03-13	Bos	
		6,199,993	2001-03-13	Mou	
		6,198,409	2001-03-06	Schofield et al.	
		6,196,688	2001-03-06	Caskey et al.	
		6,178,034	2001-01-23	Allemand et al.	
		6,176,602	2001-01-23	Pastrick et al.	
		6,172,613	2001-01-09	DeLine et al.	
		6,164,564	2000-12-26	Franco et al.	
		6,154,306	2000-11-28	Varaprasad et al.	
		6,315,419	2001-11-13	Platzer, Jr.	
		6,128,860	2000-10-10	Repp	
		6,124,647	2000-09-26	Marcus et al.	

Examiner Signature		Date Considered	
--------------------	--	-----------------	--

*EXAMINER: Initial if reference considered, whether or not citation is in conformance with MPEP 609. Draw line through citation if not in conformance and not considered. Include copy of this form with next communication to applicant. ¹ Applicant's unique citation designation number (optional). ² See Kinds Codes of USPTO Patent Documents at www.uspto.gov or MPEP 901.04. ³ Enter Office that issued the document, by the two-letter code (WIPO Standard ST.3). ⁴ For Japanese patent documents, the indication of the year of the reign of the Emperor must precede the serial number of the patent document. ⁵ Kind of document by the appropriate symbols as indicated on the document under WIPO Standard ST.16 if possible. ⁶ Applicant is to place a check mark here if English language Translation is attached.

This collection of information is required by 37 CFR 1.97 and 1.98. The information is required to obtain or retain a benefit by the public which is to file (and by the USPTO to process) an application. Confidentiality is governed by 35 U.S.C. 122 and 37 CFR 1.14. This collection is estimated to take 2 hours to complete, including gathering, preparing, and submitting the completed application form to the USPTO. Time will vary depending upon the individual case. Any comments on the amount of time you require to complete this form and/or suggestions for reducing this burden, should be sent to the Chief Information Officer, U.S. Patent and Trademark Office, P.O. Box 1450, Alexandria, VA 22313-1450. DO NOT SEND FEES OR COMPLETED FORMS TO THIS ADDRESS. SEND TO: Commissioner for Patents, P.O. Box 1450, Alexandria, VA 22313-1450.

Under the Paperwork Reduction Act of 1995, no persons are required to respond to a collection of information unless it contains a valid OMB control number.

Substitute for form 1449/PTO INFORMATION DISCLOSURE STATEMENT BY APPLICANT <i>(Use as many sheets as necessary)</i>				Complete if Known	
				Application Number	14/054,004
				Filing Date	October 15, 2013
				First Named Inventor	Niall R. Lynam
				Art Unit	2853
				Examiner Name	Alessandro V. Amari
Sheet	4	of	13	Attorney Docket Number	DON09 P-2194

U. S. PATENT DOCUMENTS					
Examiner Initials*	Cite No. ¹	Document Number	Publication Date MM-DD-YYYY	Name of Patentee or Applicant of Cited Document	Pages, Columns, Lines, Where Relevant Passages or Relevant Figures Appear
		Number-Kind Code ² (If Known)			

		6,116,743	2000-09-12	Hoek	
		6,111,684	2000-08-29	Forgette et al.	
		6,109,586	2000-08-29	Hock	
		6,097,023	2000-08-01	Schofield et al.	
		6,074,068	2000-06-13	Palathingal	
		6,065,840	2000-05-23	Caskey et al.	
		6,033,078	2000-03-07	Su et al.	
		6,032,323	2000-03-07	Smith et al.	
		6,030,084	2002-02-29	Schmidt	
		6,002,511	1999-12-14	Varaprasad et al.	
		6,001,486	1999-12-14	Varaprasad et al.	
		6,007,207	1999-12-28	Liu	
		6,005,724	1999-12-21	Todd	
		5,980,050	1999-11-09	McCord	
		5,938,320	1999-08-17	Crandall	
		5,929,786	1999-07-27	Schofield et al.	
		5,922,176	1999-07-13	Caskey	
		5,910,854	1999-06-08	Varaprasad et al.	
		5,877,897	1999-03-02	Schofield et al.	
		5,864,434	1999-01-26	Taylor	
		5,863,116	1999-01-26	Pastrick et al.	
		5,847,889	1998-12-08	Komiyama et al.	
		5,838,505	1998-11-17	Palathingal	
		5,835,294	1998-11-10	Minegishi	
		5,825,527	1998-10-20	Forgette et al.	
		5,823,654	1998-10-20	Pastrick et al.	
		5,808,777	1998-09-15	Lynam et al.	
		5,805,367	1998-09-08	Kanazawa	
		5,796,532	1998-08-18	Kanazawa	
		5,796,094	1998-08-18	Schofield et al.	
		5,793,542	1998-08-11	Kondo et al.	
		5,790,327	1998-08-04	Lee et al.	
		5,790,298	1998-08-04	Tonar	
		5,788,357	1998-08-04	Muth et al.	

Examiner Signature		Date Considered	
--------------------	--	-----------------	--

*EXAMINER: Initial if reference considered, whether or not citation is in conformance with MPEP 609. Draw line through citation if not in conformance and not considered. Include copy of this form with next communication to applicant. ¹ Applicant's unique citation designation number (optional). ² See Kinds Codes of USPTO Patent Documents at www.uspto.gov or MPEP 901.04. ³ Enter Office that issued the document, by the two-letter code (WIPO Standard ST.3). ⁴ For Japanese patent documents, the indication of the year of the reign of the Emperor must precede the serial number of the patent document. ⁵ Kind of document by the appropriate symbols as indicated on the document under WIPO Standard ST.16 if possible. ⁶ Applicant is to place a check mark here if English language Translation is attached.

This collection of information is required by 37 CFR 1.97 and 1.98. The information is required to obtain or retain a benefit by the public which is to file (and by the USPTO to process) an application. Confidentiality is governed by 35 U.S.C. 122 and 37 CFR 1.14. This collection is estimated to take 2 hours to complete, including gathering, preparing, and submitting the completed application form to the USPTO. Time will vary depending upon the individual case. Any comments on the amount of time you require to complete this form and/or suggestions for reducing this burden, should be sent to the Chief Information Officer, U.S. Patent and Trademark Office, P.O. Box 1450, Alexandria, VA 22313-1450. DO NOT SEND FEES OR COMPLETED FORMS TO THIS ADDRESS. SEND TO: Commissioner for Patents, P.O. Box 1450, Alexandria, VA 22313-1450.

Under the Paperwork Reduction Act of 1995, no persons are required to respond to a collection of information unless it contains a valid OMB control number.

Substitute for form 1449/PTO				Complete if Known	
INFORMATION DISCLOSURE STATEMENT BY APPLICANT <i>(Use as many sheets as necessary)</i>				Application Number	14/054,004
				Filing Date	October 15, 2013
				First Named Inventor	Niall R. Lynam
				Art Unit	2853
				Examiner Name	Alessandro V. Amari
				Attorney Docket Number	DON09 P-2194
Sheet	5	of	13		

U. S. PATENT DOCUMENTS					
Examiner Initials*	Cite No. ¹	Document Number	Publication Date MM-DD-YYYY	Name of Patentee or Applicant of Cited Document	Pages, Columns, Lines, Where Relevant Passages or Relevant Figures Appear
		Number-Kind Code ² (If Known)			

		5,786,772	1998-07-28	Schofield et al.	
		5,784,211	1998-07-21	Mingledorff	
		5,760,962	1998-06-02	Schofield et al.	
		5,751,489	1998-05-12	Caskey et al.	
		5,724,187	1998-03-03	Varaprasad et al.	
		5,722,836	1998-03-03	Yunker	
		5,715,093	1998-02-03	Schierbeek et al.	
		5,691,855	1997-11-25	Lupkas	
		5,689,370	1997-11-18	Tonar et al.	
		5,670,935	1997-09-23	Schofield et al.	
		5,669,705	1997-09-23	Pastrick et al.	
		5,669,704	1997-09-23	Pastrick	
		5,669,699	1997-09-23	Pastrick et al.	
		5,669,698	1997-09-23	Veldman et al.	
		5,668,663	1997-09-16	Varaprasad et al.	
		5,649,756	1997-07-22	Adams et al.	
		5,644,442	1997-07-01	Lemere	
		5,621,577	1997-04-15	Lang et al.	
		5,621,569	1997-04-15	Schlenke	
		5,610,756	1997-03-11	Lynam et al.	
		5,594,593	1997-01-14	Milner	
		5,594,222	1997-01-14	Caldwell	
		5,587,699	1996-12-24	Faloon et al.	
		5,587,236	1996-12-24	Agrawal et al.	
		5,579,133	1996-11-26	Black et al.	
		5,575,552	1996-11-19	Faloon et al.	
		5,567,360	1996-10-22	Varaprasad et al.	
		5,563,744	1996-10-08	Matsumiya	
		5,559,640	1996-09-24	Vachss et al.	
		5,557,467	1996-09-17	McColgan et al.	
		5,550,677	1996-08-27	Schofield et al.	
		5,535,056	1996-07-09	Caskey et al.	
		5,530,588	1996-06-25	Vivier	
		5,526,195	1996-06-11	Thomas	

Examiner Signature		Date Considered	
--------------------	--	-----------------	--

⁰EXAMINER: Initial if reference considered, whether or not citation is in conformance with MPEP 609. Draw line through citation if not in conformance and not considered. Include copy of this form with next communication to applicant. ¹ Applicant's unique citation designation number (optional). ² See Kinds Codes of USPTO Patent Documents at www.uspto.gov or MPEP 901.04. ³ Enter Office that issued the document, by the two-letter code (WIPO Standard ST.3). ⁴ For Japanese patent documents, the indication of the year of the reign of the Emperor must precede the serial number of the patent document. ⁵ Kind of document by the appropriate symbols as indicated on the document under WIPO Standard ST.16 if possible. ⁶ Applicant is to place a check mark here if English language Translation is attached.

This collection of information is required by 37 CFR 1.97 and 1.98. The information is required to obtain or retain a benefit by the public which is to file (and by the USPTO to process) an application. Confidentiality is governed by 35 U.S.C. 122 and 37 CFR 1.14. This collection is estimated to take 2 hours to complete, including gathering, preparing, and submitting the completed application form to the USPTO. Time will vary depending upon the individual case. Any comments on the amount of time you require to complete this form and/or suggestions for reducing this burden, should be sent to the Chief Information Officer, U.S. Patent and Trademark Office, P.O. Box 1450, Alexandria, VA 22313-1450. DO NOT SEND FEES OR COMPLETED FORMS TO THIS ADDRESS. SEND TO: Commissioner for Patents, P.O. Box 1450, Alexandria, VA 22313-1450.

Under the Paperwork Reduction Act of 1995, no persons are required to respond to a collection of information unless it contains a valid OMB control number.

Substitute for form 1449/PTO INFORMATION DISCLOSURE STATEMENT BY APPLICANT <i>(Use as many sheets as necessary)</i>				Complete if Known		
				Application Number	14/054,004	
Sheet		6	of	13	Attorney Docket Number	DON09 P-2194
					Examiner Name	Alessandro V. Amari
					First Named Inventor	Niall R. Lynam
					Filing Date	October 15, 2013
					Art Unit	2853

U. S. PATENT DOCUMENTS					
Examiner Initials*	Cite No. ¹	Document Number	Publication Date MM-DD-YYYY	Name of Patentee or Applicant of Cited Document	Pages, Columns, Lines, Where Relevant Passages or Relevant Figures Appear
		Number-Kind Code ² (If Known)			

		5,525,264	1996-06-11	Cronin et al.	
		5,523,877	1996-06-04	Lynam	
		5,517,367	1996-05-14	Kim et al.	
		5,509,606	1996-04-23	Breithaupt et al.	
		5,497,306	1996-03-05	Pastrick	
		5,497,305	1996-03-05	Pastrick et al.	
		5,483,386	1996-01-09	Carson	
		5,481,409	1996-01-02	Roberts	
		5,446,576	1995-08-29	Lynam et al.	
		5,437,931	1995-08-01	Tsai et al.	
		5,432,643	1995-07-11	Huang	
		5,424,875	1995-06-13	Davis, II	
		5,412,512	1995-05-02	Zebold et al.	
		5,406,414	1995-04-11	O'Farrell et al.	
		5,371,659	1994-12-06	Pastrick et al.	
		5,361,172	1994-11-01	Schissel et al.	
		5,355,245	1994-10-11	Lynam	
		5,354,965	1994-10-11	Lee	
		5,327,288	1994-07-05	Wellington et al.	
		5,313,335	1994-05-17	Gray et al.	
		5,296,973	1994-03-22	Burke	
		5,295,021	1994-03-15	Swanson	
		5,285,060	1994-02-08	Larson et al.	
		5,262,894	1993-11-16	Wheatley et al.	
		5,253,109	1993-10-12	O'Farrell et al.	
		5,247,395	1993-09-21	Martinez	
		5,239,405	1993-08-24	Varaprasad et al.	
		5,237,459	1993-08-17	Strauss	
		5,237,458	1993-08-17	Polanyi et al.	
		5,233,461	1993-08-03	Dornan et al.	
		5,225,943	1993-07-06	Lupo	
		5,207,492	1993-05-04	Roberts	
		5,193,029	1993-03-09	Schofield et al.	
		5,189,537	1993-02-23	O'Farrell	

Examiner Signature		Date Considered	
-----------------------	--	--------------------	--

*EXAMINER: Initial if reference considered, whether or not citation is in conformance with MPEP 609. Draw line through citation if not in conformance and not considered. Include copy of this form with next communication to applicant. ¹ Applicant's unique citation designation number (optional). ² See Kinds Codes of USPTO Patent Documents at www.uspto.gov or MPEP 901.04. ³ Enter Office that issued the document, by the two-letter code (WIPO Standard ST.3). ⁴ For Japanese patent documents, the indication of the year of the reign of the Emperor must precede the serial number of the patent document. ⁵ Kind of document by the appropriate symbols as indicated on the document under WIPO Standard ST.16 if possible. ⁶ Applicant is to place a check mark here if English language Translation is attached.

This collection of information is required by 37 CFR 1.97 and 1.98. The information is required to obtain or retain a benefit by the public which is to file (and by the USPTO to process) an application. Confidentiality is governed by 35 U.S.C. 122 and 37 CFR 1.14. This collection is estimated to take 2 hours to complete, including gathering, preparing, and submitting the completed application form to the USPTO. Time will vary depending upon the individual case. Any comments on the amount of time you require to complete this form and/or suggestions for reducing this burden, should be sent to the Chief Information Officer, U.S. Patent and Trademark Office, P.O. Box 1450, Alexandria, VA 22313-1450. DO NOT SEND FEES OR COMPLETED FORMS TO THIS ADDRESS. SEND TO: Commissioner for Patents, P.O. Box 1450, Alexandria, VA 22313-1450.

Under the Paperwork Reduction Act of 1995, no persons are required to respond to a collection of information unless it contains a valid OMB control number.

Substitute for form 1449/PTO INFORMATION DISCLOSURE STATEMENT BY APPLICANT <i>(Use as many sheets as necessary)</i>				Complete if Known	
				Application Number	14/054,004
				Filing Date	October 15, 2013
				First Named Inventor	Niall R. Lynam
				Art Unit	2853
				Examiner Name	Alessandro V. Amari
Sheet	7	of	13	Attorney Docket Number	DON09 P-2194

U. S. PATENT DOCUMENTS					
Examiner Initials*	Cite No. ¹	Document Number	Publication Date MM-DD-YYYY	Name of Patentee or Applicant of Cited Document	Pages, Columns, Lines, Where Relevant Passages or Relevant Figures Appear
		Number-Kind Code ² (If Known)			

		5,183,099	1993-02-02	Bechu	
		5,179,471	1993-01-12	Caskey et al.	
		5,178,448	1993-01-12	Adams et al.	
		5,166,833	1992-11-24	Shyu	
		5,151,824	1992-09-29	O'Farrell	
		5,151,816	1992-09-29	Varaprasad et al.	
		5,142,407	1992-08-25	Varaprasad et al.	
		5,140,455	1992-08-18	Varaprasad et al.	
		5,118,540	1992-06-02	Hutchison	
		5,117,346	1992-05-26	Gard	
		5,115,352	1992-05-19	do Espirito Santo	
		5,115,346	1992-05-19	Lynam	
		5,107,374	1992-04-21	Lupo et al.	
		5,085,907	1992-02-04	Smith	
		5,080,492	1992-01-14	Platzer, Jr.	
		5,078,480	1992-01-07	Warszawski	
		5,076,673	1991-12-31	Lynam et al.	
		5,073,012	1991-12-17	Lynam	
		5,066,112	1991-11-19	Lynam et al.	
		5,052,792	1991-10-01	McDonough	
		5,050,977	1991-09-24	Platzer, Jr.	
		5,044,739	1991-09-03	do Espirito Santo	
		5,033,835	1991-07-23	Platzer, Jr.	
		5,022,747	1991-06-11	Polanyi et al.	
		5,014,167	1991-05-07	Roberts	
		5,005,962	1991-04-09	Edelman	
		4,989,964	1991-02-05	Meise	
		4,948,242	1990-08-14	Desmond et al.	
		4,944,581	1990-07-31	Ichikawa	
		4,932,770	1990-06-12	Caravaty	
		4,932,769	1990-06-12	Goosen	
		4,929,074	1990-05-29	Urban	
		4,917,485	1990-04-17	Baldwin, Sr.	
		4,913,542	1990-04-03	Adolfsson	

Examiner Signature		Date Considered	
--------------------	--	-----------------	--

*EXAMINER: Initial if reference considered, whether or not citation is in conformance with MPEP 609. Draw line through citation if not in conformance and not considered. Include copy of this form with next communication to applicant. ¹ Applicant's unique citation designation number (optional). ² See Kinds Codes of USPTO Patent Documents at www.uspto.gov or MPEP 901.04. ³ Enter Office that issued the document, by the two-letter code (WIPO Standard ST.3). ⁴ For Japanese patent documents, the indication of the year of the reign of the Emperor must precede the serial number of the patent document. ⁵ Kind of document by the appropriate symbols as indicated on the document under WIPO Standard ST.16 if possible. ⁶ Applicant is to place a check mark here if English language Translation is attached.

This collection of information is required by 37 CFR 1.97 and 1.98. The information is required to obtain or retain a benefit by the public which is to file (and by the USPTO to process) an application. Confidentiality is governed by 35 U.S.C. 122 and 37 CFR 1.14. This collection is estimated to take 2 hours to complete, including gathering, preparing, and submitting the completed application form to the USPTO. Time will vary depending upon the individual case. Any comments on the amount of time you require to complete this form and/or suggestions for reducing this burden, should be sent to the Chief Information Officer, U.S. Patent and Trademark Office, P.O. Box 1450, Alexandria, VA 22313-1450. DO NOT SEND FEES OR COMPLETED FORMS TO THIS ADDRESS. SEND TO: Commissioner for Patents, P.O. Box 1450, Alexandria, VA 22313-1450.

Under the Paperwork Reduction Act of 1995, no persons are required to respond to a collection of information unless it contains a valid OMB control number.

Substitute for form 1449/PTO				Complete if Known	
				Application Number	14/054,004
INFORMATION DISCLOSURE STATEMENT BY APPLICANT <i>(Use as many sheets as necessary)</i>				Filing Date	October 15, 2013
				First Named Inventor	Niall R. Lynam
				Art Unit	2853
				Examiner Name	Alessandro V. Amari
				Attorney Docket Number	DON09 P-2194
				Sheet	8

U. S. PATENT DOCUMENTS					
Examiner Initials*	Cite No. ¹	Document Number	Publication Date MM-DD-YYYY	Name of Patentee or Applicant of Cited Document	Pages, Columns, Lines, Where Relevant Passages or Relevant Figures Appear
		Number-Kind Code ² (If Known)			

		4,906,085	1990-03-06	Sugihara et al.	
		4,906,075	1990-03-06	Majsumiya	
		4,882,565	1989-11-21	Gallmeyer	
		4,882,466	1989-11-21	Friel	
		4,859,046	1989-08-22	Traynor et al.	
		4,853,283	1989-08-01	Skolnick	
		4,828,379	1989-05-09	Parsons et al.	
		4,826,289	1989-05-02	Vandenbrink et al.	
		4,824,231	1989-04-25	Quintana	
		4,799,768	1989-01-24	Gahan	
		4,793,690	1988-12-27	Gahan et al.	
		4,773,740	1988-09-27	Kawakami et al.	
		4,770,522	1988-09-13	Alten	
		4,737,188	1988-04-12	Bahls	
		4,733,336	1988-03-22	Skogler et al.	
		4,727,302	1988-02-23	Mizuta et al.	
		4,721,364	1988-01-26	Itoh et al.	
		4,715,701	1987-12-29	Urban	
		4,712,879	1987-12-15	Lynam et al.	
		4,679,906	1987-07-14	Brandenburg	
		4,678,294	1987-07-01	Van Nostrand	
		4,674,850	1987-06-23	Blom	
		4,674,849	1987-06-23	Stewart	
		4,666,264	1987-05-19	Yamabe	
		4,630,904	1986-12-23	Pastore	
		4,629,296	1986-12-16	White	
		4,623,222	1986-11-18	Itoh et al.	
		4,609,266	1986-09-02	Blom	
		4,588,267	1986-05-13	Pastore	
		4,575,202	1986-03-11	McGuire	
		4,555,166	1985-11-26	Enomoto	
		4,549,786	1985-10-29	Albers et al.	
		4,526,446	1985-07-02	Adams	
		4,499,451	1985-02-12	Suzuki et al.	

Examiner Signature		Date Considered	
--------------------	--	-----------------	--

*EXAMINER: Initial if reference considered, whether or not citation is in conformance with MPEP 609. Draw line through citation if not in conformance and not considered. Include copy of this form with next communication to applicant. ¹ Applicant's unique citation designation number (optional). ² See Kinds Codes of USPTO Patent Documents at www.uspto.gov or MPEP 901.04. ³ Enter Office that issued the document, by the two-letter code (WIPO Standard ST.3). ⁴ For Japanese patent documents, the indication of the year of the reign of the Emperor must precede the serial number of the patent document. ⁵ Kind of document by the appropriate symbols as indicated on the document under WIPO Standard ST.16 if possible. ⁶ Applicant is to place a check mark here if English language Translation is attached.

This collection of information is required by 37 CFR 1.97 and 1.98. The information is required to obtain or retain a benefit by the public which is to file (and by the USPTO to process) an application. Confidentiality is governed by 35 U.S.C. 122 and 37 CFR 1.14. This collection is estimated to take 2 hours to complete, including gathering, preparing, and submitting the completed application form to the USPTO. Time will vary depending upon the individual case. Any comments on the amount of time you require to complete this form and/or suggestions for reducing this burden, should be sent to the Chief Information Officer, U.S. Patent and Trademark Office, P.O. Box 1450, Alexandria, VA 22313-1450. DO NOT SEND FEES OR COMPLETED FORMS TO THIS ADDRESS. SEND TO: Commissioner for Patents, P.O. Box 1450, Alexandria, VA 22313-1450.

Under the Paperwork Reduction Act of 1995, no persons are required to respond to a collection of information unless it contains a valid OMB control number.

Substitute for form 1449/PTO INFORMATION DISCLOSURE STATEMENT BY APPLICANT <i>(Use as many sheets as necessary)</i>				Complete if Known		
				Application Number	14/054,004	
Sheet		9	of	13	Attorney Docket Number	DON09 P-2194
					Examiner Name	Alessandro V. Amari
					First Named Inventor	Niall R. Lynam
					Filing Date	October 15, 2013
					Art Unit	2853

U. S. PATENT DOCUMENTS					
Examiner Initials*	Cite No. ¹	Document Number	Publication Date MM-DD-YYYY	Name of Patentee or Applicant of Cited Document	Pages, Columns, Lines, Where Relevant Passages or Relevant Figures Appear
		Number-Kind Code ² (If Known)			

		4,470,665	1984-09-11	Blom	
		4,449,786	1984-05-22	McCord	
		4,439,013	1984-03-27	Hagn et al.	
		4,436,372	1984-03-13	Schmidt et al.	
		4,436,371	1984-03-13	Wood et al.	
		4,435,042	1984-03-06	Wood et al.	
		4,385,804	1983-05-31	Tamura et al.	
		4,350,412	1982-09-21	Steenblik et al.	
		4,331,382	1982-05-25	Graff	
		4,325,609	1982-04-20	Alford	
		4,311,363	1982-01-19	Marsalka et al.	
		4,311,362	1982-01-19	LaPorte	
		4,306,770	1981-12-22	Marhauer	
		4,303,308	1981-12-01	Kobrin	
		4,293,191	1981-10-06	Kim	
		4,281,899	1981-08-04	Oskam	
		4,268,120	1981-05-19	Jitsumori	
		4,264,144	1981-04-28	McCord	
		4,258,979	1981-03-31	Mahin	
		4,223,983	1980-09-23	Bloom	
		4,200,359	1980-04-29	Lawson	
		4,193,668	1980-03-18	Skinner	
		3,909,117	1975-09-30	Takahashi et al.	
		3,884,606	1975-05-20	Schrenk	
		3,881,811	1975-05-06	French	
		3,826,563	1974-07-30	Davis	
		3,806,232	1974-04-23	Gray	
		3,773,882	1973-11-20	Schrenk	
		3,764,201	1973-10-09	Haile	
		3,759,647	1973-09-18	Schrenk et al.	
		3,708,222	1973-01-02	Stern	
		3,667,833	1972-06-06	Baldwin, Sr.	
		3,610,739	1971-10-05	Seashore	
		3,601,614	1971-08-24	Platzer, Jr.	

Examiner Signature		Date Considered	
-----------------------	--	--------------------	--

*EXAMINER: Initial if reference considered, whether or not citation is in conformance with MPEP 609. Draw line through citation if not in conformance and not considered. Include copy of this form with next communication to applicant. ¹ Applicant's unique citation designation number (optional). ² See Kinds Codes of USPTO Patent Documents at www.uspto.gov or MPEP 901.04. ³ Enter Office that issued the document, by the two-letter code (WIPO Standard ST.3). ⁴ For Japanese patent documents, the indication of the year of the reign of the Emperor must precede the serial number of the patent document. ⁵ Kind of document by the appropriate symbols as indicated on the document under WIPO Standard ST.16 if possible. ⁶ Applicant is to place a check mark here if English language Translation is attached.

This collection of information is required by 37 CFR 1.97 and 1.98. The information is required to obtain or retain a benefit by the public which is to file (and by the USPTO to process) an application. Confidentiality is governed by 35 U.S.C. 122 and 37 CFR 1.14. This collection is estimated to take 2 hours to complete, including gathering, preparing, and submitting the completed application form to the USPTO. Time will vary depending upon the individual case. Any comments on the amount of time you require to complete this form and/or suggestions for reducing this burden, should be sent to the Chief Information Officer, U.S. Patent and Trademark Office, P.O. Box 1450, Alexandria, VA 22313-1450. DO NOT SEND FEES OR COMPLETED FORMS TO THIS ADDRESS. SEND TO: Commissioner for Patents, P.O. Box 1450, Alexandria, VA 22313-1450.

Under the Paperwork Reduction Act of 1995, no persons are required to respond to a collection of information unless it contains a valid OMB control number.

Substitute for form 1449/PTO INFORMATION DISCLOSURE STATEMENT BY APPLICANT <i>(Use as many sheets as necessary)</i>				Complete if Known		
				Application Number	14/054,004	
Sheet		10	of	13	Attorney Docket Number	DON09 P-2194

U. S. PATENT DOCUMENTS					
Examiner Initials*	Cite No. ¹	Document Number	Publication Date MM-DD-YYYY	Name of Patentee or Applicant of Cited Document	Pages, Columns, Lines, Where Relevant Passages or Relevant Figures Appear
		Number-Kind Code ² (If Known)			

		3,563,638	1971-02-16	Panozzo	
		3,424,517	1969-01-28	Budreck	
		3,408,136	1968-10-29	Travis	
		3,404,935	1968-10-08	Creager	
		3,389,952	1968-06-25	Tobin, Jr.	
		3,375,053	1968-03-26	Ward	
		3,338,655	1967-08-29	Young	
		3,337,285	1967-08-22	Travis	
		3,280,701	1966-10-25	Donnelly et al.	
		3,267,806	1966-08-23	Azegami	
		3,266,016	1966-08-09	Maruyama et al.	
		3,175,463	1965-03-30	Seashore	
		3,170,985	1965-02-23	Katulich	
		3,146,296	1964-08-25	Fischer	
		3,131,250	1964-04-28	Ely	
		3,104,274	1963-09-17	King	
		2,911,177	1959-11-03	West	
		2,890,539	1959-06-16	Holt	
		2,279,751	1942-04-14	Elwood	
		2,778,273	1957-01-22	Fellmeth	
		2,636,419	1953-04-28	Kerr	
		2,580,014	1951-12-25	Gazda	
		2,514,989	1950-07-11	Buren	
		2,263,382	1941-11-18	Gotzinger	
		2,135,262	1938-11-01	Schumacher	
		1,672,559	1928-06-05	Doble	
		1,114,559	1914-10-20	Weed	
		D297,926	1988-10-04	Kesler	
		D493,394	2004-07-27	Lawlor et al.	
		D493,131	2004-07-20	Lawlor et al.	
		2002/0036828	2002-03-28	Wong	
		2002/0048100	2002-04-25	Hoek	
		2002/0072026	2002-06-04	Lynam et al.	
		2002/0105741	2002-08-08	Platzer, Jr.	

Examiner Signature		Date Considered	
-----------------------	--	--------------------	--

*EXAMINER: Initial if reference considered, whether or not citation is in conformance with MPEP 609. Draw line through citation if not in conformance and not considered. Include copy of this form with next communication to applicant. ¹ Applicant's unique citation designation number (optional). ² See Kinds Codes of USPTO Patent Documents at www.uspto.gov or MPEP 901.04. ³ Enter Office that issued the document, by the two-letter code (WIPO Standard ST.3). ⁴ For Japanese patent documents, the indication of the year of the reign of the Emperor must precede the serial number of the patent document. ⁵ Kind of document by the appropriate symbols as indicated on the document under WIPO Standard ST.16 if possible. ⁶ Applicant is to place a check mark here if English language Translation is attached.

This collection of information is required by 37 CFR 1.97 and 1.98. The information is required to obtain or retain a benefit by the public which is to file (and by the USPTO to process) an application. Confidentiality is governed by 35 U.S.C. 122 and 37 CFR 1.14. This collection is estimated to take 2 hours to complete, including gathering, preparing, and submitting the completed application form to the USPTO. Time will vary depending upon the individual case. Any comments on the amount of time you require to complete this form and/or suggestions for reducing this burden, should be sent to the Chief Information Officer, U.S. Patent and Trademark Office, P.O. Box 1450, Alexandria, VA 22313-1450. DO NOT SEND FEES OR COMPLETED FORMS TO THIS ADDRESS. SEND TO: Commissioner for Patents, P.O. Box 1450, Alexandria, VA 22313-1450.

Under the Paperwork Reduction Act of 1995, no persons are required to respond to a collection of information unless it contains a valid OMB control number.

Substitute for form 1449/PTO				Complete if Known	
				Application Number	14/054,004
INFORMATION DISCLOSURE STATEMENT BY APPLICANT <i>(Use as many sheets as necessary)</i>				Filing Date	October 15, 2013
				First Named Inventor	Niall R. Lynam
				Art Unit	2853
				Examiner Name	Alessandro V. Amari
				Attorney Docket Number	DON09 P-2194
Sheet	11	of	13		

U. S. PATENT DOCUMENTS					
Examiner Initials*	Cite No. ¹	Document Number	Publication Date MM-DD-YYYY	Name of Patentee or Applicant of Cited Document	Pages, Columns, Lines, Where Relevant Passages or Relevant Figures Appear
		Number-Kind Code ² (If Known)			

		2002/0159169	2002-10-31	McCord	
		2002/0159270	2002-10-31	Lynam et al.	
		2003/0026009	2003-02-06	Vandenbrink	
		2003/0026012	2003-02-06	Pavao	
		2003/0031023	2003-02-13	Hutzel	
		2003/0043589	2003-03-06	Blank	
		2003/0117731	2003-06-26	Platzer, Jr.	
		2004/0032675	2004-02-19	Weller et al.	
		2004/0032638	2004-02-19	Tonar et al.	
		2004/0032676	2004-02-19	Drummond et al.	
		2004/0114260	2004-06-17	Bartnick	
		2004/0165291	2004-08-26	Platzer, Jr.	
		2004/0257685	2004-12-23	Minor et al.	
		2004/0264011	2004-12-30	Lynam	
		2005/0078389	2005-04-14	Kulas et al.	
		2005/0083577	2005-04-21	Varaprasad et al.	
		2005/0099693	2005-05-12	Schofield et al.	
		2005/0134983	2005-06-23	Lynam	
		2005/0232469	2005-10-20	Schofield et al.	
		2005/0248859	2005-11-10	Platzer, Jr.	
		2006/0050018	2006-03-09	Hutzel et al.	
		2006/0061008	2006-03-23	Karner et al.	
		2006/0125919	2006-06-15	Camilleri et al.	
		2006/0126150	2006-06-15	Tonar et al.	
		2006/0171704	2006-08-03	Bingle et al.	
		2006/0184297	2006-08-17	Higgins-Luthman	
		2006/0268440	2006-11-30	Platzer, Jr.	
		2006/0279863	2006-12-14	Starbuck	
		2007/0058257	2007-03-15	Lynam	
		2007/0285789	2007-12-13	Lindahl et al.	
		2008/0212189	2008-09-04	Baur et al.	
		2008/0225421	2008-09-18	Platzer	
		2008/0304170	2008-12-11	Zhao	
		2008/0308219	2008-12-18	Lynam	

Examiner Signature		Date Considered	
--------------------	--	-----------------	--

*EXAMINER: Initial if reference considered, whether or not citation is in conformance with MPEP 609. Draw line through citation if not in conformance and not considered. Include copy of this form with next communication to applicant. ¹ Applicant's unique citation designation number (optional). ² See Kinds Codes of USPTO Patent Documents at www.uspto.gov or MPEP 901.04. ³ Enter Office that issued the document, by the two-letter code (WIPO Standard ST.3). ⁴ For Japanese patent documents, the indication of the year of the reign of the Emperor must precede the serial number of the patent document. ⁵ Kind of document by the appropriate symbols as indicated on the document under WIPO Standard ST.16 if possible. ⁶ Applicant is to place a check mark here if English language Translation is attached.

This collection of information is required by 37 CFR 1.97 and 1.98. The information is required to obtain or retain a benefit by the public which is to file (and by the USPTO to process) an application. Confidentiality is governed by 35 U.S.C. 122 and 37 CFR 1.14. This collection is estimated to take 2 hours to complete, including gathering, preparing, and submitting the completed application form to the USPTO. Time will vary depending upon the individual case. Any comments on the amount of time you require to complete this form and/or suggestions for reducing this burden, should be sent to the Chief Information Officer, U.S. Patent and Trademark Office, P.O. Box 1450, Alexandria, VA 22313-1450. DO NOT SEND FEES OR COMPLETED FORMS TO THIS ADDRESS. SEND TO: Commissioner for Patents, P.O. Box 1450, Alexandria, VA 22313-1450.

Under the Paperwork Reduction Act of 1995, no persons are required to respond to a collection of information unless it contains a valid OMB control number.

Substitute for form 1449/PTO				Complete if Known	
INFORMATION DISCLOSURE STATEMENT BY APPLICANT <i>(Use as many sheets as necessary)</i>				Application Number	14/054,004
				Filing Date	October 15, 2013
				First Named Inventor	Niall R. Lynam
				Art Unit	2853
				Examiner Name	Alessandro V. Amari
Sheet	13	of	13	Attorney Docket Number	DON09 P-2194

FOREIGN PATENT DOCUMENTS							
Examiner initials*	Cite No. ¹	Foreign Patent Document		Publication Date MM-DD-YYYY	Name of Patentee or Applicant of Cited Document	Pages, Columns, Lines, Where Relevant Passages Or Relevant Figures Appear	T ⁶
		Country Code ²	Number ³ -Kind Code ⁴ <i>(if known)</i>				

		DE	2409748	1975-09-04	Leitz		
		DE	2550095	1976-05-20	Schiff et al.		
		DE	2647592	1978-04-27	Uta		
		DE	2915521	1980-10-30	Docie		
		DE	3302735	1984-08-02	Schulze		X
		DE	3329998	1985-03-07	Horn		X
		DE	3620228	1987-12-17	Thomen		X
		DE	4026578	1992-04-30	Kramer		X
		EP	0210757	1987-02-04	Von Seidel		X
		EP	0310261	1989-04-05	Britax Wingard Limited		X
		EP	0551802	1992-01-15	Jonsson		X
		EP	0791503	1997-08-27	Gentex Corporation		X
		EP	0917987	1999-05-26	Magneti Marelli France		X
		EP	0356099	1990-02-28	Yamada et al.		X
		EP	0728618	08-28-1996	Gentex Corporation		X
		EP	0729864	09-04-1996	Gentex Corporation		X
		FR	2628042	1988-03-01	Racel		X
		GB	1279158	1972-06-28	Hacker		X
		GB	2048189	1980-12-10	Mirrocraft Inc.		X
		GB	2092534	1982-08-18	Hagiri		X
		JP	0051637	1980-04-15	Katsumata Giken KK		X
		JP	55076721	1980-10-06	Nikken Kogyo KK		X
		JP	1186443	1989-07-25	Kitsumoto Norihiko		X
		JP	1208245	1989-08-22	Moriwake		X
		JP	362075619	1987-04-07	Tomita		X
		JP	62105103	1987-05-15	Miyake Shinya		X
		KR	2002092059	2002-12-11	Jung		X
		NL	7908257	1981-06-01	Bartholomeus		
		TW	424057	2001-03-01	Lin		X
		WO	2001081956	11-01-2001	Platzer, Jr.		X
		WO	2004026633	04-01-2004	Donnelly Corporation		X
		WO	2004047421	06-03-2004	Donnelly Corporation		X
		WO	2004103772	12-02-2004	Donnelly Corporation		X
		WO	2006124682	11-23-2006	Donnelly Corporation		X
		WO	2007005942	01-11-2007	Donnelly Corporation		X
		WO	2008051910	05-02-2008	Donnelly Corporation		X

Examiner Signature		Date Considered	
--------------------	--	-----------------	--

*EXAMINER: Initial if reference considered, whether or not citation is in conformance with MPEP 609. Draw line through citation if not in conformance and not considered. Include copy of this form with next communication to applicant. ¹ Applicant's unique citation designation number (optional). ² See Kinds Codes of USPTO Patent Documents at www.uspto.gov or MPEP 901.04. ³ Enter Office that issued the document, by the two-letter code (WIPO Standard ST.3). ⁴ For Japanese patent documents, the indication of the year of the reign of the Emperor must precede the serial number of the patent document. ⁵ Kind of document by the appropriate symbols as indicated on the document under WIPO Standard ST.16 if possible. ⁶ Applicant is to place a check mark here if English language Translation is attached.

This collection of information is required by 37 CFR 1.97 and 1.98. The information is required to obtain or retain a benefit by the public which is to file (and by the USPTO to process) an application. Confidentiality is governed by 35 U.S.C. 122 and 37 CFR 1.14. This collection is estimated to take 2 hours to complete, including gathering, preparing, and submitting the completed application form to the USPTO. Time will vary depending upon the individual case. Any comments on the amount of time you require to complete this form and/or suggestions for reducing this burden, should be sent to the Chief Information Officer, U.S. Patent and Trademark Office, P.O. Box 1450, Alexandria, VA 22313-1450. DO NOT SEND FEES OR COMPLETED FORMS TO THIS ADDRESS. SEND TO: Commissioner for Patents, P.O. Box 1450, Alexandria, VA 22313-1450.

Electronic Acknowledgement Receipt

EFS ID:	17423596
Application Number:	14054004
International Application Number:	
Confirmation Number:	4390
Title of Invention:	EXTENDED FIELD OF VIEW EXTERIOR MIRROR ELEMENT FOR VEHICLE
First Named Inventor/Applicant Name:	Niall R. Lynam
Customer Number:	15671
Filer:	Timothy A. Flory/Amanda Sytsma
Filer Authorized By:	Timothy A. Flory
Attorney Docket Number:	DON09 P-2194
Receipt Date:	18-NOV-2013
Filing Date:	15-OCT-2013
Time Stamp:	12:49:09
Application Type:	Utility under 35 USC 111(a)

Payment information:

Submitted with Payment	no
------------------------	----

File Listing:

Document Number	Document Description	File Name	File Size(Bytes)/ Message Digest	Multi Part /.zip	Pages (if appl.)
1	Transmittal Letter	TransmittalForm.pdf	119311 <small>7b45c1447a0a9748c38ec3592b19ea57e3f1a3ff</small>	no	1

Warnings:

Information:

2	Transmittal Letter	IDSLetter.pdf	15691	no	1
			69f53345ff5a8b546d978f236b32b52e078fc91		

Warnings:

Information:

3	Information Disclosure Statement (IDS) Form (SB08)	IDSForms.pdf	192044	no	13
			d083eccdab6344ca423ea4e90b3d85375bd0d9f17		

Warnings:

Information:

This is not an USPTO supplied IDS fillable form

Total Files Size (in bytes):	327046
-------------------------------------	--------

This Acknowledgement Receipt evidences receipt on the noted date by the USPTO of the indicated documents, characterized by the applicant, and including page counts, where applicable. It serves as evidence of receipt similar to a Post Card, as described in MPEP 503.

New Applications Under 35 U.S.C. 111

If a new application is being filed and the application includes the necessary components for a filing date (see 37 CFR 1.53(b)-(d) and MPEP 506), a Filing Receipt (37 CFR 1.54) will be issued in due course and the date shown on this Acknowledgement Receipt will establish the filing date of the application.

National Stage of an International Application under 35 U.S.C. 371

If a timely submission to enter the national stage of an international application is compliant with the conditions of 35 U.S.C. 371 and other applicable requirements a Form PCT/DO/EO/903 indicating acceptance of the application as a national stage submission under 35 U.S.C. 371 will be issued in addition to the Filing Receipt, in due course.

New International Application Filed with the USPTO as a Receiving Office

If a new international application is being filed and the international application includes the necessary components for an international filing date (see PCT Article 11 and MPEP 1810), a Notification of the International Application Number and of the International Filing Date (Form PCT/RO/105) will be issued in due course, subject to prescriptions concerning national security, and the date shown on this Acknowledgement Receipt will establish the international filing date of the application.

Under the Paperwork Reduction Act of 1995, no persons are required to respond to a collection of information unless it displays a valid OMB control number.

TRANSMITTAL FORM <i>(to be used for all correspondence after initial filing)</i>	Application Number	14/054,004
	Filing Date	October 15, 2013
	First Named Inventor	Niall R. Lynam
	Art Unit	2872
	Examiner Name	Alessandro V. Amari
Total Number of Pages in This Submission		Attorney Docket Number DON09 P-2194

ENCLOSURES (Check all that apply)		
<input type="checkbox"/> Fee Transmittal Form	<input type="checkbox"/> Drawing(s)	<input type="checkbox"/> After Allowance Communication to TC
<input type="checkbox"/> Fee Attached	<input type="checkbox"/> Licensing-related Papers	<input type="checkbox"/> Appeal Communication to Board of Appeals and Interferences
<input type="checkbox"/> Amendment/Reply	<input type="checkbox"/> Petition	<input type="checkbox"/> Appeal Communication to TC (Appeal Notice, Brief, Reply Brief)
<input type="checkbox"/> After Final	<input type="checkbox"/> Petition to Convert to a Provisional Application	<input type="checkbox"/> Proprietary Information
<input type="checkbox"/> Affidavits/declaration(s)	<input type="checkbox"/> Power of Attorney, Revocation	<input type="checkbox"/> Status Letter
<input type="checkbox"/> Extension of Time Request	<input type="checkbox"/> Change of Correspondence Address	<input type="checkbox"/> Other Enclosure(s) (please Identify below):
<input type="checkbox"/> Express Abandonment Request	<input type="checkbox"/> Terminal Disclaimer	
<input checked="" type="checkbox"/> Information Disclosure Statement	<input type="checkbox"/> Request for Refund	
<input type="checkbox"/> Certified Copy of Priority Document(s)	<input type="checkbox"/> CD, Number of CD(s) _____	
<input type="checkbox"/> Reply to Missing Parts/ Incomplete Application	<input type="checkbox"/> Landscape Table on CD	
<input type="checkbox"/> Reply to Missing Parts under 37 CFR 1.52 or 1.53	Remarks	

SIGNATURE OF APPLICANT, ATTORNEY, OR AGENT			
Firm Name	GARDNER, LINN, BURKHART & FLORY, LLP		
Signature	/taf/		
Printed name	Timothy A. Flory		
Date	November 18, 2013	Reg. No.	42540

CERTIFICATE OF TRANSMISSION/MAILING			
I hereby certify that this correspondence is being facsimile transmitted to the USPTO or deposited with the United States Postal Service with sufficient postage as first class mail in an envelope addressed to: Commissioner for Patents, P.O. Box 1450, Alexandria, VA 22313-1450 on the date shown below:			
Signature	/ars/		
Typed or printed name	Amanda R. Sytsma	Date	November 18, 2013

This collection of information is required by 37 CFR 1.5. The information is required to obtain or retain a benefit by the public which is to file (and by the USPTO to process) an application. Confidentiality is governed by 35 U.S.C. 122 and 37 CFR 1.11 and 1.14. This collection is estimated to 2 hours to complete, including gathering, preparing, and submitting the completed application form to the USPTO. Time will vary depending upon the individual case. Any comments on the amount of time you require to complete this form and/or suggestions for reducing this burden, should be sent to the Chief Information Officer, U.S. Patent and Trademark Office, U.S. Department of Commerce, P.O. Box 1450, Alexandria, VA 22313-1450. DO NOT SEND FEES OR COMPLETED FORMS TO THIS ADDRESS. SEND TO: **Commissioner for Patents, P.O. Box 1450, Alexandria, VA 22313-1450.**

If you need assistance in completing the form, call 1-800-PTO-9199 and select option 2.

IN THE UNITED STATES PATENT AND TRADEMARK OFFICE

Group : 2853
Examiner : Alessandro V. Amari
Inventor : Niall R. Lynam
Serial No. : 14/054,004
Filing Date : October 15, 2013
For : EXTENDED FIELD OF VIEW EXTERIOR MIRROR ELEMENT FOR VEHICLE

Mail Stop Amendment
Commissioner for Patents
P.O. Box 1450
Alexandria, VA 22313-1450

Dear Sir:

INFORMATION DISCLOSURE STATEMENT

In accordance with 37 CFR 1.51, 1.56, 1.97 and 1.98, Applicants submit herewith patents, publications or other information listed on the attached PTO/SB/08A forms for consideration by the Examiner in connection with examination of the present application. Copies of the cited non-U.S. patent/publication references are not provided herewith, since these references were previously made of record during prosecution of the parent application Serial No. 13/776,247. The Examiner is invited to contact the undersigned attorney if an additional copy of any of these references is desired.

This Information Disclosure Statement is not intended to constitute an admission that any patent, publication or other information referred to herein is "prior art" for this invention unless specifically designated as such.

Under 37 CFR 1.97, the filing of this Information Disclosure Statement shall not be construed to mean that a search has been made or that no other material information as defined in 37 CFR 1.56(a) exists.

An early and favorable action on the merits is respectfully requested.

Respectfully submitted,

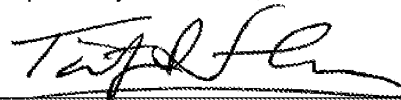

Date: November 18, 2013

Timothy A. Flory
Registration No. 42 540
Gardner, Linn, Burkhart & Flory, LLP
2851 Charlevoix Drive, S.E., Suite 207
Grand Rapids, Michigan 49546
(616) 975-5500



UNITED STATES PATENT AND TRADEMARK OFFICE

UNITED STATES DEPARTMENT OF COMMERCE
United States Patent and Trademark Office
Address: COMMISSIONER FOR PATENTS
P.O. Box 1450
Alexandria, Virginia 22313-1450
www.uspto.gov

APPLICATION NUMBER	FILING OR 371(C) DATE	FIRST NAMED APPLICANT	ATTY. DOCKET NO./TITLE
14/054,004	10/15/2013	Niall R. Lynam	DON09 P-2194

15671
Gardner, Linn, Burkhart & Flory, LLP
2851 Charlevoix Dr., SE, Suite 207
Grand Rapids, MI 49546

CONFIRMATION NO. 4390
IMPROPER CFR REQUEST



Date Mailed: 11/20/2013

RESPONSE TO REQUEST FOR CORRECTED FILING RECEIPT

Continuity, Priority Claims, Petitions, and Non-Publication Requests

In response to your request for a corrected Filing Receipt, the Office is unable to comply with your request because:

- To correct or update the benefit claim of a U.S. prior-filed application, applicant must submit a corrected application data sheet (ADS) with the desired benefit claim. If a corrected ADS is submitted, any deletions should be shown with strikethrough and any additions should be shown with underlining. A domestic benefit claim that is presented after the time period set forth in 37 CFR 1.78 must be accompanied by a petition under 37 CFR 1.78. Note that once a benefit claim is deleted, applicant will not be able to claim such prior-filed application again, if the above-identified application was filed on or after November 29, 2000.

/tran/

Office of Data Management, Application Assistance Unit (571) 272-4000, or (571) 272-4200, or 1-888-786-0101



UNITED STATES PATENT AND TRADEMARK OFFICE

UNITED STATES DEPARTMENT OF COMMERCE
United States Patent and Trademark Office
Address: COMMISSIONER FOR PATENTS
P.O. Box 1450
Alexandria, Virginia 22313-1450
www.uspto.gov

Table with 5 columns: APPLICATION NO., FILING DATE, FIRST NAMED INVENTOR, ATTORNEY DOCKET NO., CONFIRMATION NO. Includes sub-tables for EXAMINER, ART UNIT, PAPER NUMBER, NOTIFICATION DATE, and DELIVERY MODE.

Please find below and/or attached an Office communication concerning this application or proceeding.

The time period for reply, if any, is set in the attached communication.

Notice of the Office communication was sent electronically on above-indicated "Notification Date" to the following e-mail address(es):

sytsma@glbf.com
patents@glbf.com
clark@glbf.com

Office Action Summary	Application No. 14/054,004	Applicant(s) LYNAM, NIAL R.	
	Examiner KIMBERLY N. KAKALEC	Art Unit 2872	AIA (First Inventor to File) Status No

-- The MAILING DATE of this communication appears on the cover sheet with the correspondence address --

Period for Reply

A SHORTENED STATUTORY PERIOD FOR REPLY IS SET TO EXPIRE 3 MONTHS FROM THE MAILING DATE OF THIS COMMUNICATION.

- Extensions of time may be available under the provisions of 37 CFR 1.136(a). In no event, however, may a reply be timely filed after SIX (6) MONTHS from the mailing date of this communication.
- If NO period for reply is specified above, the maximum statutory period will apply and will expire SIX (6) MONTHS from the mailing date of this communication.
- Failure to reply within the set or extended period for reply will, by statute, cause the application to become ABANDONED (35 U.S.C. § 133). Any reply received by the Office later than three months after the mailing date of this communication, even if timely filed, may reduce any earned patent term adjustment. See 37 CFR 1.704(b).

Status

- 1) Responsive to communication(s) filed on _____.
 A declaration(s)/affidavit(s) under **37 CFR 1.130(b)** was/were filed on _____.
- 2a) This action is **FINAL**. 2b) This action is non-final.
- 3) An election was made by the applicant in response to a restriction requirement set forth during the interview on _____; the restriction requirement and election have been incorporated into this action.
- 4) Since this application is in condition for allowance except for formal matters, prosecution as to the merits is closed in accordance with the practice under *Ex parte Quayle*, 1935 C.D. 11, 453 O.G. 213.

Disposition of Claims*

- 5) Claim(s) 1-20 is/are pending in the application.
5a) Of the above claim(s) _____ is/are withdrawn from consideration.
- 6) Claim(s) _____ is/are allowed.
- 7) Claim(s) 1-20 is/are rejected.
- 8) Claim(s) _____ is/are objected to.
- 9) Claim(s) _____ are subject to restriction and/or election requirement.

* If any claims have been determined allowable, you may be eligible to benefit from the **Patent Prosecution Highway** program at a participating intellectual property office for the corresponding application. For more information, please see http://www.uspto.gov/patents/init_events/pph/index.jsp or send an inquiry to PPHfeedback@uspto.gov.

Application Papers

- 10) The specification is objected to by the Examiner.
- 11) The drawing(s) filed on 10/15/2013 is/are: a) accepted or b) objected to by the Examiner.
Applicant may not request that any objection to the drawing(s) be held in abeyance. See 37 CFR 1.85(a).
Replacement drawing sheet(s) including the correction is required if the drawing(s) is objected to. See 37 CFR 1.121(d).

Priority under 35 U.S.C. § 119

- 12) Acknowledgment is made of a claim for foreign priority under 35 U.S.C. § 119(a)-(d) or (f).

Certified copies:

- a) All b) Some** c) None of the:
1. Certified copies of the priority documents have been received.
 2. Certified copies of the priority documents have been received in Application No. _____.
 3. Copies of the certified copies of the priority documents have been received in this National Stage application from the International Bureau (PCT Rule 17.2(a)).

** See the attached detailed Office action for a list of the certified copies not received.

Attachment(s)

- 1) Notice of References Cited (PTO-892)
- 2) Information Disclosure Statement(s) (PTO/SB/08a and/or PTO/SB/08b)
Paper No(s)/Mail Date _____.
- 3) Interview Summary (PTO-413)
Paper No(s)/Mail Date. _____.
- 4) Other: _____.

DETAILED ACTION

Notice of Pre-AIA or AIA Status

The present application is being examined under the pre-AIA first to invent provisions.

Priority

Applicant's claim for the benefit of a prior-filed application under 35 U.S.C. 119(e) or under 35 U.S.C. 120, 121, or 365(c) is acknowledged. Applicant has not complied with one or more conditions for receiving the benefit of an earlier filing date under 35 U.S.C. 120 as follows:

The later-filed application must be an application for a patent for an invention which is also disclosed in the prior application (the parent or original nonprovisional application or provisional application). The disclosure of the invention in the parent application and in the later-filed application must be sufficient to comply with the requirements of 35 U.S.C. 112(a) or the first paragraph of pre-AIA 35 U.S.C. 112, except for the best mode requirement. See *Transco Products, Inc. v. Performance Contracting, Inc.*, 38 F.3d 551, 32 USPQ2d 1077 (Fed. Cir. 1994)

The disclosure of the prior-filed application, Application No. 12/197,666 (and its parent Application No. 10/709,434 and Provisional Application No. 60/471,872), fails to provide adequate support or enablement in the manner provided by 35 U.S.C. 112(a) or pre-AIA 35 U.S.C. 112, first paragraph for one or more claims of this application.

Application No. 12/197,666 fails to provide adequate support for "a main plano mirror element fixedly disposed at a first portion of said mirror backing plate element; ... an auxiliary non-plano curved mirror element fixedly disposed at a second portion of said mirror backing plate element; wherein said main plano mirror element and said auxiliary non-plano curved mirror element are adjacently disposed at said mirror backing plate element in a side-by-side

relationship and are not superimposed with one mirror element on top of the other mirror element; ... wherein said first primary field of view of said main plano mirror element overlaps said second auxiliary field of view of said auxiliary non-plano curved mirror element.”

Accordingly, claims 1-20 are not entitled to the benefit of this prior application.

It is noted that the earliest-filed parent application that provides adequate support and enablement for the above claimed features is Application No. 12/851,045. Accordingly, claims 1-20 are entitled to the benefit of the filing date of that prior application, August 5, 2010.

Claim Rejections - 35 USC § 103

The following is a quotation of pre-AIA 35 U.S.C. 103(a) which forms the basis for all obviousness rejections set forth in this Office action:

(a) A patent may not be obtained though the invention is not identically disclosed or described as set forth in section 102 of this title, if the differences between the subject matter sought to be patented and the prior art are such that the subject matter as a whole would have been obvious at the time the invention was made to a person having ordinary skill in the art to which said subject matter pertains. Patentability shall not be negated by the manner in which the invention was made.

The factual inquiries set forth in *Graham v. John Deere Co.*, 383 U.S. 1, 148 USPQ 459 (1966), that are applied for establishing a background for determining obviousness under pre-AIA 35 U.S.C. 103(a) are summarized as follows:

1. Determining the scope and contents of the prior art.
2. Ascertaining the differences between the prior art and the claims at issue.
3. Resolving the level of ordinary skill in the pertinent art.
4. Considering objective evidence present in the application indicating obviousness or nonobviousness.

Claims 1-20 are rejected under pre-AIA 35 U.S.C. 103(a) as being unpatentable over Lynam et al. (US 2002/0072026 A1).

The first, second and fourth embodiments of Lynam are directed to exterior rearview mirrors. Therefore, they are analogous art.

Regarding claim 1, Lynam discloses an exterior sideview mirror assembly suitable for use on a vehicle, said exterior sideview mirror assembly comprising: a mirror housing (Fig. 3: 40 – exterior mirror housing); a mirror backing plate element (Fig. 3: 60 – backing plate element); wherein said mirror backing plate element (Fig. 3: 60 - backing plate element) is movable within said mirror housing (Fig. 2: 40 – exterior mirror housing) by an electrically-operable actuator (Fig. 2: 36 – actuator) (para [0041]: electrically actuated actuator... Plano-multiradius reflective element 30 is positionable by actuator 36 within exterior mirror housing 40; para [0042]: backing plate element 60 is preferably adapted to attach, such as by attachment member 64, to actuator 36 when plano-multiradius reflective element assembly 30 is mounted in driver-side exterior sideview mirror assembly 12 such that plano element 50 and multiradius element 55 are adjusted and positioned in tandem and simultaneously); a main plano mirror element (Fig. 3: 50 - plano element) fixedly disposed at a first portion of said mirror backing plate element (Fig. 3: the portion of backing plate element 60 between points E & F); said main plano mirror element (Fig. 3: 50 – plano element) having a first primary field of view rearward of a vehicle equipped with said exterior sideview mirror assembly (para [0046]: field of view of the plano reflective element); an auxiliary non-plano curved mirror element (Fig. 3: 55 – multiradius element) fixedly disposed at a second portion of said mirror backing plate element (Fig. 3: the portion of backing plate element 60 between points G & H); wherein said main plano mirror element (Fig.

Art Unit: 2872

3: 50 – plano element) and said auxiliary non-plano curved mirror element (Fig. 3: 55 – multiradius element) are adjacently disposed at said mirror backing plate element (Fig. 3: 60 – backing plate element) in a side-by-side relationship and are not superimposed with one mirror element on top of the other mirror element (as shown in Fig. 3); said auxiliary non-plano curved mirror element (Fig. 3: 55 – multiradius element) having a second auxiliary field of view rearward of the equipped vehicle (para [0046]: field of view... of the auxiliary reflective element); wherein said auxiliary non-plano curved mirror element (Fig. 3: 55 – multiradius element) that is at said second portion of said mirror backing plate element (Fig. 3: the portion of backing plate element 60 between points G & H) is angled relative to said main plano mirror element (Fig. 3: 55 – plano element) that is at said first portion of said mirror backing plate element (Fig. 3: the portion of backing plate element 60 between points E & F) (as shown in Fig. 3) (para [0059]: the portion of the backing plate element that the multiradius reflective element is attached to can be angled relative to the adjacent portion of the backing plate element that the plano reflective portion is attached to); wherein said mirror backing plate element (Fig. 3: 60 – backing plate element) mounts to said actuator (Fig. 3: 36 – actuator) such that movement of said mirror backing plate element (Fig. 3: 60 – backing plate element) by said actuator (Fig. 36 - actuator) simultaneously and similarly moves said main plano mirror element (Fig. 3: 50 – plano element) and said auxiliary non-plano curved mirror element (Fig. 3: 55 – multiradius element) (para [0042]: backing plate element 60 is preferably adapted to attach, such as by attachment member 64, to actuator 36... such that plano element 50 and multiradius element 55 are adjusted and positioned in tandem and simultaneously when the driver activates actuator 36); wherein said mirror backing plate element (Fig. 3: 60 – backing plate element) comprises a polymeric

Art Unit: 2872

molding (para [0050]: Backing plate element 60 is preferably a rigid polymeric substrate); wherein said main plano mirror element (Fig. 3: 50 – plano element) comprises a generally flat glass substrate having a surface coated with a metallic reflector coating (para [0050]: Plano element 50 can be cut from a stock lite of flat chromium mirror-coated 1.6 mm thick glass); wherein the overall rearward field of view of said main plano mirror element (Fig. 3: 50 – plano element) combined with said auxiliary non-plano curved mirror element (Fig. 3: 55 – multiradius element) is at least about 25 degrees relative to the side of the equipped vehicle (para [0046]: The total field of view rearwardly of the automobile of the plano-auxiliary reflective element assembly (which is a combination of the field of view of the plano reflective element and of the auxiliary reflective element) ... more preferably, generally subtends an angle of at least about 25°); and wherein the overall rearward field of view of said main plano mirror element (Fig. 3: 50 – plano element) combined with said auxiliary non-plano curved mirror element (Fig. 3: 55 – multiradius element) is less than about 50 degrees relative to the side of the equipped vehicle (para [0046]: The total field of view rearwardly of the automobile of the plano-auxiliary reflective element assembly (which is a combination of the field of view of the plano reflective element and of the auxiliary reflective element) ... most preferably, generally subtends an angle of at least about 30°).

In the above first embodiment, Lynam neither teaches nor suggests said first primary field of view of said main plano mirror element overlaps said second auxiliary field of view of said auxiliary non-plano curved mirror element.

However, in a fourth embodiment, Lynam discloses two reflective elements (Lynam Fig. 8: 312 & 314 - reflective elements) (para [0065]: reflective element 312 comprises a plano

reflective element 350; para [0069]: second reflective element 314 comprises a radiused reflective element and, more preferably, a multiradiused reflective element 355) having overlapping fields of view (para [0077]: reflective elements 312 and 314 have overlapping field of views). Lynam teaches that this allows an image in the field of view of one of the reflective elements to transition or move between the elements and appear in both during the transition to thereby enable the driver of the automobile to view or be conscious of the object continuously (Lynam para [0077]).

It would have been obvious to one of ordinary skill in the art at the time of the invention to modify the exterior sideview mirror assembly of the first embodiment of Lynam by configuring the first primary field of view of the main plano mirror element and the second auxiliary field of view of the auxiliary non-plano curved mirror element to overlap, as taught in the separate embodiment of Lynam, in order to enable the driver of the automobile to view or be conscious of an object continuously.

Regarding independent claim 15, Lynam discloses all the limitations in common with claim 1 above and such is hereby incorporated. Lynam further discloses said auxiliary non-plano curved mirror element (Fig. 3: 55 – multiradius element) comprises a metallic reflector coating and wherein said auxiliary non-plano curved mirror element (Fig. 3: 55 – multiradius element) comprises a curved glass substrate (para [0050]: Multiradius element 55 can be cut from a stock lite of multiradiusly-bent chromium mirror-coated 1.6 mm thick glass); wherein said second portion of said mirror backing plate element (Fig. 3: the portion of backing plate element 60 between points G & H) has a curvature at least partially matching the curvature of said auxiliary non-plano curved mirror element (para [0050]: Backing plate element 60 also comprises a

curved portion (generally between G and H as shown in Fig. 3) that corresponds to and is aligned with multiradius element 55. Preferably, curved portion G-H of multiradius element 55 is fabricated with a multiradius prescription that is substantially the same as the multiradius prescription of multiradius element 55).

Regarding independent claim 18, Lynam discloses all the limitations in common with claim 1 above and such is hereby incorporated. Lynam further discloses said main plano mirror element (Fig. 3: 50 - plano element) has a fixed reflectance (para [0043]: Plano element 50 may comprise a conventional fixed reflectance mirror reflector) and wherein said auxiliary non-plano curved mirror element (Fig. 3: 55 – multiradius element) has a fixed reflectance (para [0047]: Multiradius element 55 may comprise a conventional fixed reflectance mirror reflector); wherein said first primary field of view of said main plano mirror element (Lynam Fig. 8: 312 – reflective element) overlaps said second auxiliary field of view of said auxiliary non-plano curved mirror element (Fig. 8: 314 - reflective element) by between about 2 degrees and about 20 degrees (para [0076]: field of views 360 and 362 overlap over a range having angle D in a range of about 20° to about 2°).

Regarding claim 2, Lynam discloses said auxiliary non-plano curved mirror element (Fig. 3: 55 – multiradius element) comprises a reflector-coated convex-curved substrate (para [0050]: Multiradius element 55 can be cut from a stock lite of multiradiusly-bent chromium mirror-coated 1.6 mm thick glass) (see Fig. 3, showing convex curve) and wherein said second portion of said mirror backing plate element (Fig. 3: the portion of backing plate element 60 between points G & H) is convex-curved (see Fig. 3, showing convex curve; see also para [0050]:

Backing plate element 60 also comprises a curved portion (generally between G and H as shown in Fig. 3) that corresponds to and is aligned with multiradius element 55).

In the first and fourth embodiments, Lynam neither teaches nor suggests said auxiliary non-plano curved mirror element has a spherical curvature.

However, Lynam generally teaches that a spherical reflective element can be used instead of a multiradius reflective element (para [0083]: a spherical reflective element... can optionally be used adjacent the plano reflective element instead of, or in addition to, the multiradius reflective element). Lynam further teaches that spherically curved reflectors increase the field of view rearward (para [0005]: The field of view rearward increases at the degree of curvature of the bent substrate increases).

It would have been obvious to one of ordinary skill in the art at the time of the invention to modify the exterior sideview mirror assembly of Lynam by comprising selecting an auxiliary non-plano curved mirror element having a spherical curvature, as taught generally by Lynam, in order to increase the rearward field of view.

Regarding claim 3, Lynam discloses said second portion of said mirror backing plate element (Fig. 3: the portion of backing plate element 60 between points G & H) has a curvature at least partially matching said spherical curvature of said auxiliary non-plano curved mirror element (Fig. 3: 55 – multiradius element) (para [0083]: spherical reflective element... can optionally be used; para [0050]: Backing plate element 60 also comprises a curved portion (generally between G and H as shown in Fig. 3) that corresponds to and is aligned with multiradius element 55).

Regarding claims 4, 16 & 19, Lynam discloses, when used in the exterior sideview mirror assembly of the equipped vehicle, said main plano mirror element (Fig. 8: 312 – reflective element) has a rearward field of view that generally subtends an angle of less than about 20 degrees relative to the side of the equipped vehicle (para [0076]: reflective element 312 has a field of view 360 which forms an angle A with respect to the longitudinal center line of the vehicle in a range of about 8° to about 20°), and wherein said auxiliary non-plano curved mirror element (Fig. 8: 314 – second reflective element) has a rearward field of view that generally subtends an angle that is in the range from about 15 degrees relative to the side of the equipped vehicle to about 50 degrees relative to the side of the equipped vehicle (para [0076]: reflective element 314 has a field of view 362 which forms an angle C in a range of about 15° to about 50°).

Regarding claims 5, 17 & 20, Lynam discloses said main plano mirror element (Fig. 8: 314 – reflective element) has an X-axis and a Y-axis (as shown in Fig. 8) and wherein, when disposed at said second portion of said mirror backing plate element (Fig. 8: 328 – support surface), said auxiliary non-plano curved mirror element (Fig. 8: 314 – second reflective element) is at least one of (a) tilted generally downward with respect to the Y-axis of said main plano mirror element by an angle that is in the range from about 0.75 degrees to about 5 degrees (para [0074]: Reflective element 314 is also tilted downwardly with respect to the Y-axis of the reflective element 312 at an angle... in a range of about 0.75° to about 5°) and (b) tilted generally forwardly with respect to the X-axis of said main plano mirror element by an angle that is in the range from about 0.75 degrees to about 5 degrees (para [0074]: reflective element 314 is

tilted forwardly at an angle... with respect to the X-axis of reflective element 312... in a range of about 0.75° to about 5°).

Regarding claim 6, Lynam discloses all the limitations in common with claim 1 above and such is hereby incorporated.

In the first and fourth embodiments, Lynam neither teaches nor suggests the second auxiliary field of view rearward of the equipped vehicle views into a blind spot in a side lane adjacent the side of the equipped vehicle at which said exterior sideview mirror assembly is, and wherein said blind spot is generally outside the rearward field of view of said main plano mirror element when said main plano mirror element is viewed by a driver of the equipped vehicle when said exterior sideview mirror assembly is attached at the side of the equipped vehicle attached.

However, in a second embodiment, Lyman discloses an auxiliary reflective element angled with respect to a plano element such that the second auxiliary field of view rearward of the equipped vehicle views into a blind spot in a side lane adjacent the side of the equipped vehicle at which said exterior sideview mirror assembly is, and wherein said blind spot is generally outside the rearward field of view of said main plano mirror element when said main plano mirror element is viewed by a driver of the equipped vehicle when said exterior sideview mirror assembly is attached at the side of the equipped vehicle attached (para [0052]: Such angling of the auxiliary reflective element relative to the plano element can be advantageous in allowing the auxiliary reflective element view a portion of the road adjacent the automobile that is in a blind spot of the plano reflective element).

It would have been obvious to one of ordinary skill in the art at the time of the invention to modify the exterior sideview mirror assembly of Lynam by configuring it such that an auxiliary reflective element angled with respect to a plano element such that the second auxiliary field of view rearward of the equipped vehicle views into a blind spot in a side lane adjacent the side of the equipped vehicle at which said exterior sideview mirror assembly is, and wherein said blind spot is generally outside the rearward field of view of said main plano mirror element when said main plano mirror element is viewed by a driver of the equipped vehicle when said exterior sideview mirror assembly is attached at the side of the equipped vehicle attached, as taught in the further embodiment of Lynam, in order reduce accidents due to blind spots.

Regarding claim 7, Lynam discloses said auxiliary non-plano curved mirror element (Fig. 3: 55 – multiradius element) comprises a reflector-coated convex-curved glass substrate (para [0050]: Multiradius element 55 can be cut from a stock lite of multiradiusly-bent chromium mirror-coated 1.6 mm thick glass) (see Fig. 3, showing convex curve) and wherein said second portion of said mirror backing plate element (Fig. 3: the portion of backing plate element between points G & H) is convex-curved (see Fig. 3, showing convex curve; see also para [0050]: Backing plate element 60 also comprises a curved portion (generally between G and H as shown in Fig. 3) that corresponds to and is aligned with multiradius element 55); and said second portion of said mirror backing plate element (Fig. 3: the portion of backing plate element 60 between points G & H) has curvature substantially matching said curvature of said auxiliary non-plano curved mirror element (Fig. 3: 55 – multiradius element) (para [0050]: Backing plate element 60 also comprises a curved portion (generally between G and H as shown in Fig. 3) that corresponds to and is aligned with multiradius element 55).

In the first and fourth embodiments, Lynam neither teaches nor suggests said auxiliary non-plano curved mirror element has a spherical curvature.

However, Lynam generally teaches that a spherical reflective element can be used instead of a multiradius reflective element (para [0083]: a spherical reflective element... can optionally be used adjacent the plano reflective element instead of, or in addition to, the multiradius reflective element). Lynam further teaches that spherically curved reflectors increase the field of view rearward (para [0005]: The field of view rearward increases at the degree of curvature of the bent substrate increases).

It would have been obvious to one of ordinary skill in the art at the time of the invention to modify the exterior sideview mirror assembly of the first and fourth embodiments of Lynam by selecting an auxiliary non-plano curved mirror element having a spherical curvature, as taught generally by Lynam, in order to increase the rearward field of view.

Regarding claim 8, Lynam discloses said first primary field of view of said main plano mirror element (Fig. 8: 312 – reflective element) overlaps said second auxiliary field of view of said auxiliary non-plano curved mirror element (Fig. 8: 314 – reflective element) by between about 2 degrees and about 20 degrees (para [0076]: field of views 360 and 362 overlap over a range having angle D in a range of about 20° to about 2°).

Regarding claim 9, Lynam discloses said main plano mirror element (Fig. 3: 50 – plano element) has a fixed reflectance (para [0043]: Plano element 50 may comprise a conventional fixed reflectance mirror reflector) and wherein said auxiliary non-plano curved mirror element (Fig. 3: 55 – multiradius element) has a fixed reflectance (para [0047]: Multiradius element 55 may comprise a conventional fixed reflectance mirror reflector).

Regarding claim 10, Lynam discloses said main plano mirror element (Fig. 3: 50 – plano element) is disposed at said mirror backing plate element (Fig. 3: 60 – backing plate element) by at least one of an adhesive attachment and a mechanical attachment and wherein said auxiliary non-plano curved mirror element (Fig. 3: 55 – multiradius element) is disposed at said mirror backing plate element by at least one of an adhesive attachment and a mechanical attachment (para [0050]: Plano element 50 and multiradius element 55 can then be attached (such as by an adhesive attachment such as an adhesive pad or by mechanical attachment)... to the already molded backing plate element), and wherein said auxiliary non-plano curved mirror element (Fig. 3: 55 – multiradius element) comprises a bent glass substrate having a surface coated with a metallic reflector (para [0050]: Multiradius element 55 can be cut from a stock lite of multiradiusly-bent chromium mirror-coated 1.6 mm thick glass).

Regarding claim 11, Lynam discloses said main plano mirror element (Fig. 3: 50 – plano element) comprises a substrate having a surface coated with a metallic reflector coating (para [0050]: Plano element 50 can be cut from a stock lite of flat chromium mirror-coated 1.6 mm thick glass) and wherein said auxiliary non-plano curved mirror element (Fig. 3: 55 – multiradius element) comprises a substrate having a surface coated with a metallic reflector coating (para [0050]: Multiradius element 55 can be cut from a stock lite of multiradiusly-bent chromium mirror-coated 1.6 mm thick glass), and wherein said second portion of said mirror backing plate element (Fig. 3: the portion of backing plate element 60 between points G & H) comprises a curvature corresponding to a curvature of said auxiliary non-plano curved mirror element (Fig. 3: 55 – multiradius element) (para [0050]: Backing plate element 60 also comprises a curved portion (generally between G and H as shown in Fig. 3) that corresponds to and is aligned with

multiradius element 55. Preferably, curved portion G-H of multiradius element 55 is fabricated with a multiradius prescription that is substantially the same as the multiradius prescription of multiradius element 55), and wherein said second portion of said mirror backing plate element (Fig. 3: the portion of backing plate element 60 between points G & H) comprises at least one of (a) a spherical curvature, (b) an aspherical curvature and (c) a multiradius curvature (para [0050]: Preferably, curved portion G-H of multiradius element 55 is fabricated with a multiradius prescription that is substantially the same as the multiradius prescription of multiradius element 55).

Regarding claim 12, Lynam discloses said auxiliary non-plano curved mirror element (Fig. 3: 55 – multiradius element) comprises a heater element operable to demist/deice the outmost surface of said auxiliary non-plano curved mirror element when said auxiliary non-plano curved mirror element is disposed at said mirror backing plate element (Fig. 3: 60 – backing plate element) (para [0054]: multiradius element 55 can comprise a heater element... that is operable to deice/demist surfaces 66, 68) and when said exterior sideview mirror assembly is attached and operated at the side of the equipped vehicle, and wherein said exterior sideview mirror assembly comprises a driver-side exterior sideview mirror assembly (see Fig. 2 & para [0041]: Automobile 10 further includes a driver-side exterior sideview mirror assembly 12; para [0059]: plano-multiradius reflective element assembly is mounted and operated in an exterior sideview mirror assembly on an automobile).

Regarding claim 13, Lynam discloses said exterior sideview mirror assembly comprises a door-mounted driver-side exterior sideview mirror assembly of the equipped vehicle (Fig. 1 & para [0041]: Exterior sideview mirrors, mounted as shown in Fig. 1 close to the driver

seating location, are commonly referred to as door-mounted exterior sideview mirror assemblies), and wherein said auxiliary non-plano curved mirror element (Fig. 3: 55 – multiradius element) comprises a glass substrate having a surface coated with a metallic reflector coating (para [0050]: Multiradius element 55 can be cut from a stock lite of multiradiusly-bent chromium mirror-coated 1.6 mm thick glass), and wherein said metallic reflector coating is selected from the group consisting of (i) a chromium coating, (ii) a titanium coating, (iii) a rhodium coating, (iv) a metal-alloy coating, (v) a nickel alloy coating, (vi) an aluminum coating and (vii) a silver coating (para [0050]: chromium mirror-coated).

Regarding claim 14, Lynam discloses said auxiliary non-plano curved mirror element (Fig. 3: 55 – multiradius element) comprises a metallic reflector coating (para [0050]: Multiradius element 55 can be cut from a stock lite of multiradiusly-bent chromium mirror-coated 1.6 mm thick glass).

In the first and fourth embodiments, Lynam neither teaches nor suggests said auxiliary non-plano curved mirror element comprises a spherically bent curved glass substrate.

However, Lynam generally teaches that a spherical reflective element can be used instead of a multiradius reflective element (para [0083]: a spherical reflective element... can optionally be used adjacent the plano reflective element instead of, or in addition to, the multiradius reflective element). Lynam further teaches that spherically curved reflectors increase the field of view rearward (para [0005]: The field of view rearward increases at the degree of curvature of the bent substrate increases).

It would have been obvious to one of ordinary skill in the art at the time of the invention to modify the exterior sideview mirror assembly of the first and fourth embodiments of Lynam

by comprising the auxiliary non-plano curved mirror element of a spherically bent curved glass substrate, as taught generally by Lynam, in order to increase the rearward field of view.

Conclusion

Any inquiry concerning this communication or earlier communications from the examiner should be directed to KIMBERLY N. KAKALEC whose telephone number is (571)270-5802. The examiner can normally be reached on Monday through Thursday, 8:30 am to 6:00 pm EST, Alt. Fridays 8:30 am to 5:00 pm EST.

If attempts to reach the examiner by telephone are unsuccessful, the examiner's supervisor, Stephone B. Allen can be reached on (571)272-2434. The fax phone number for the organization where this application or proceeding is assigned is 571-273-8300.

Information regarding the status of an application may be obtained from the Patent Application Information Retrieval (PAIR) system. Status information for published applications may be obtained from either Private PAIR or Public PAIR. Status information for unpublished applications is available through Private PAIR only. For more information about the PAIR system, see <http://pair-direct.uspto.gov>. Should you have questions on access to the Private PAIR system, contact the Electronic Business Center (EBC) at 866-217-9197 (toll-free). If you would like assistance from a USPTO Customer Service Representative or access to the automated information system, call 800-786-9199 (IN USA OR CANADA) or 571-272-1000.

/K. N. K./
Examiner, Art Unit 2872

/STEPHONE B. ALLEN/
Supervisory Patent Examiner, Art Unit 2872

Application/Control Number: 14/054,004
Art Unit: 2872

Page 18

EAST Search History

EAST Search History (Prior Art)

Ref #	Hits	Search Query	DBs	Default Operator	Plurals	Time Stamp
S1	2	10/709,434.app.	US-PGPUB; USPAT	ADJ	ON	2013/12/05 10:28
S2	218	"10/709,434"	US-PGPUB; USPAT	ADJ	ON	2013/12/05 10:28
S3	97	"10/709,434"	USPAT	ADJ	ON	2013/12/05 10:30
S4	2	(plano mirror and auxiliary non?plano curved mirror).clm.	USPAT	ADJ	ON	2013/12/05 10:30
S5	713	((NIALL) near2 (LYNAM)).INV.	US-PGPUB; USPAT	ADJ	ON	2013/12/05 10:35
S6	282	S5 and (plano or planar) and (curv\$ or non?plano or non?planar)	US-PGPUB; USPAT	ADJ	ON	2013/12/05 10:40
S7	6322	359/838,850,864,868-869,871-878,881-884.ccls.	US-PGPUB; USPAT	ADJ	ON	2013/12/05 10:42
S8	2951	S7 and (vehicle or automobile or car or truck or van)	US-PGPUB; USPAT	ADJ	ON	2013/12/05 10:42
S9	435	S8 and (plano or planar) and (curv\$ or non?plano or non?planar)	US-PGPUB; USPAT	ADJ	ON	2013/12/05 10:43
S10	248	("1114559" "1672559" "2135262" "2263382" "2279751" "2514989" "2580014" "2636419" "2778273" "2890539" "2911177" "20020036828" "20020048100" "20020072026" "20020105741" "20020159169" "20020159270" "20030026009" "20030026012" "20030031023" "20030043589" "20030117731" "20040032638" "20040032675" "20040032676" "20040114260" "20040165291" "20040257685" "20040264011" "20050078389" "20050083577" "20050099693" "20050134983" "20050232469" "20050248859" "20060050018" "20060061008" "20060125919" "20060126150" "20060171704" "20060184297" "20060268440" "20060279863" "20070058257" "20070285789" "20080212189" "20080225421" "20080304170" "20080308219" "20090040306" "20090115631" "20090237820" "20090268321" "20100195228"	US-PGPUB; USPAT	ADJ	ON	2013/12/05 10:53

"20100296187"	"20110157732"	
"20110170207"	"20120314316"	
"20130188237"	"20130188269"	"3104274"
"3131250"	"3146296"	"3170985"
"3175463"	"3266016"	"3267806"
"3280701"	"3337285"	"3338655"
"3375053"	"3389952"	"3404935"
"3408136"	"3424517"	"3563638"
"3601614"	"3610739"	"3667833"
"3708222"	"3759647"	"3764201"
"3773882"	"3806232"	"3826563"
"3881811"	"3884606"	"3909117"
"4193668"	"4200359"	"4223983"
"4258979"	"4264144"	"4268120"
"4281899"	"4293191"	"4303308"
"4306770"	"4311362"	"4311363"
"4325609"	"4331382"	"4350412"
"4385804"	"4435042"	"4436371"
"4436372"	"4439013"	"4449786"
"4470665"	"4499451"	"4526446"
"4549786"	"4555166"	"4575202"
"4588267"	"4609266"	"4623222"
"4629296"	"4630904"	"4666264"
"4674849"	"4674850"	"4678294"
"4679906"	"4712879"	"4715701"
"4721364"	"4727302"	"4733336"
"4737188"	"4770522"	"4773740"
"4793690"	"4799768"	"4824231"
"4826289"	"4828379"	"4853283"
"4859046"	"4882466"	"4882565"
"4906075"	"4906085"	"4913542"
"4917485"	"4929074"	"4932769"
"4932770"	"4944581"	"4948242"
"4989964"	"5005962"	"5014167"
"5022747"	"5033835"	"5044739"
"5050977"	"5052792"	"5066112"
"5073012"	"5076673"	"5078480"
"5080492"	"5085907"	"5107374"
"5115346"	"5115352"	"5117346"
"5118540"	"5140455"	"5142407"
"5151816"	"5151824"	"5166833"
"5178448"	"5179471"	"5183099"
"5189537"	"5193029"	"5207492"
"5225943"	"5233461"	"5237458"
"5237459"	"5239405"	"5247395"
"5253109"	"5262894"	"5285060"
"5295021"	"5296973"	"5313335"
"5327288"	"5354965"	"5355245"
"5361172"	"5371659"	"5406414"
"5412512"	"5424875"	"5432643"
"5437931"	"5446576"	"5481409"
"5483386"	"5497305"	"5497306"
"5509606"	"5517367"	"5523877"
"5525264"	"5526195"	"5530588"
"5535056"	"5550677"	"5557467"
"5559640"	"5563744"	"5567360"
"5575552"	"5579133"	"5587236"
"5587699"	"5594222"	"5594593"
"5610756"	"5621569"	"5621577"
"5644442"	"5649756"	"5668663"
"5669698"	"5669699"	"5669704"
"5669705"	"5670935"	"5689370"
"5691855"	"5715093"	"5722836"
"5724187"	"5751489"	"5760962"

		"5784211" "5786772" "5788357" "5790298").PN.				
S11	137	("5790327" "5793542" "5796094" "5796532" "5805367" "5808777" "5823654" "5825527" "5835294" "5838505" "5847889" "5863116" "5864434" "5877897" "5910854" "5922176" "5929786" "5938320" "5980050" "6001486" "6002511" "6005724" "6007207" "6030084" "6032323" "6033078" "6065840" "6074068" "6097023" "6109586" "6111684" "6116743" "6124647" "6128860" "6154306" "6164564" "6172613" "6176602" "6178034" "6196688" "6198409" "6199993" "6201642" "6207083" "6227689" "6245262" "6250148" "6257746" "6260608" "6270225" "6276821" "6286965" "6294989" "6310611" "6315419" "6318870" "6320282" "6329925" "6341523" "6343402" "6356376" "6390632" "6396397" "6398377" "6409354" "6420036" "6428172" "6441964" "6445287" "6449082" "6472979" "6498620" "6501387" "6511192" "6512624" "6522451" "6537138" "6582109" "6595649" "6615438" "6627918" "6642851" "6648477" "6669109" "6690268" "6709119" "6717610" "6717712" "6719215" "6731205" "6737629" "6742904" "6757109" "6824281" "6831268" "6882287" "6919796" "6932483" "6979090" "7001032" "7005974" "7025469" "7038577" "7097312" "7106392" "7126456" "7167294" "7168830" "7184190" "7195381" "7249860" "7255451" "7267448" "7274501" "7289037" "7338177" "7339149" "7345680" "7370983" "7377675" "7391563" "7400435" "7420756" "7423522" "7492281" "7526103" "7581859" "7626749" "7636188" "7857469" "7934843" "8267534" "8562157" "D297926" "D493131" "D493394" "RE17274").pn.	US- PGPUB; USPAT	ADJ	ON	2013/12/05 10:54
S12	385	S10 or S11	US- PGPUB; USPAT	ADJ	ON	2013/12/05 10:54
S13	248	("1114559" "1672559" "2135262" "2263382" "2279751" "2514989" "2580014" "2636419" "2778273" "2890539" "2911177" "20020036828" "20020048100" "20020072026" "20020105741" "20020159169" "20020159270" "20030026009" "20030026012" "20030031023" "20030043589" "20030117731" "20040032638" "20040032675" "20040032676" "20040114260" "20040165291" "20040257685"	US- PGPUB; USPAT	ADJ	ON	2013/12/05 14:53

"20040264011"	"20050078389"	
"20050083577"	"20050099693"	
"20050134983"	"20050232469"	
"20050248859"	"20060050018"	
"20060061008"	"20060125919"	
"20060126150"	"20060171704"	
"20060184297"	"20060268440"	
"20060279863"	"20070058257"	
"20070285789"	"20080212189"	
"20080225421"	"20080304170"	
"20080308219"	"20090040306"	
"20090115631"	"20090237820"	
"20090268321"	"20100195228"	
"20100296187"	"20110157732"	
"20110170207"	"20120314316"	
"20130188237"	"20130188269"	"3104274"
"3131250"	"3146296"	"3170985"
"3175463"	"3266016"	"3267806"
"3280701"	"3337285"	"3338655"
"3375053"	"3389952"	"3404935"
"3408136"	"3424517"	"3563638"
"3601614"	"3610739"	"3667833"
"3708222"	"3759647"	"3764201"
"3773882"	"3806232"	"3826563"
"3881811"	"3884606"	"3909117"
"4193668"	"4200359"	"4223983"
"4258979"	"4264144"	"4268120"
"4281899"	"4293191"	"4303308"
"4306770"	"4311362"	"4311363"
"4325609"	"4331382"	"4350412"
"4385804"	"4435042"	"4436371"
"4436372"	"4439013"	"4449786"
"4470665"	"4499451"	"4526446"
"4549786"	"4555166"	"4575202"
"4588267"	"4609266"	"4623222"
"4629296"	"4630904"	"4666264"
"4674849"	"4674850"	"4678294"
"4679906"	"4712879"	"4715701"
"4721364"	"4727302"	"4733336"
"4737188"	"4770522"	"4773740"
"4793690"	"4799768"	"4824231"
"4826289"	"4828379"	"4853283"
"4859046"	"4882466"	"4882565"
"4906075"	"4906085"	"4913542"
"4917485"	"4929074"	"4932769"
"4932770"	"4944581"	"4948242"
"4989964"	"5005962"	"5014167"
"5022747"	"5033835"	"5044739"
"5050977"	"5052792"	"5066112"
"5073012"	"5076673"	"5078480"
"5080492"	"5085907"	"5107374"
"5115346"	"5115352"	"5117346"
"5118540"	"5140455"	"5142407"
"5151816"	"5151824"	"5166833"
"5178448"	"5179471"	"5183099"
"5189537"	"5193029"	"5207492"
"5225943"	"5233461"	"5237458"
"5237459"	"5239405"	"5247395"
"5253109"	"5262894"	"5285060"
"5295021"	"5296973"	"5313335"
"5327288"	"5354965"	"5355245"
"5361172"	"5371659"	"5406414"
"5412512"	"5424875"	"5432643"
"5437931"	"5446576"	"5481409"

EAST Search History

		"5483386" "5497305" "5497306" "5509606" "5517367" "5523877" "5525264" "5526195" "5530588" "5535056" "5550677" "5557467" "5559640" "5563744" "5567360" "5575552" "5579133" "5587236" "5587699" "5594222" "5594593" "5610756" "5621569" "5621577" "5644442" "5649756" "5668663" "5669698" "5669699" "5669704" "5669705" "5670935" "5689370" "5691855" "5715093" "5722836" "5724187" "5751489" "5760962" "5784211" "5786772" "5788357" "5790298") .PN.				
S14	137	("5790327" "5793542" "5796094" "5796532" "5805367" "5808777" "5823654" "5825527" "5835294" "5838505" "5847889" "5863116" "5864434" "5877897" "5910854" "5922176" "5929786" "5938320" "5980050" "6001486" "6002511" "6005724" "6007207" "6030084" "6032323" "6033078" "6065840" "6074068" "6097023" "6109586" "6111684" "6116743" "6124647" "6128860" "6154306" "6164564" "6172613" "6176602" "6178034" "6196688" "6198409" "6199993" "6201642" "6207083" "6227689" "6245262" "6250148" "6257746" "6260608" "6270225" "6276821" "6286965" "6294989" "6310611" "6315419" "6318870" "6320282" "6329925" "6341523" "6343402" "6356376" "6390632" "6396397" "6398377" "6409354" "6420036" "6428172" "6441964" "6445287" "6449082" "6472979" "6498620" "6501387" "6511192" "6512624" "6522451" "6537138" "6582109" "6595649" "6615438" "6627918" "6642851" "6648477" "6669109" "6690268" "6709119" "6717610" "6717712" "6719215" "6731205" "6737629" "6742904" "6757109" "6824281" "6831268" "6882287" "6919796" "6932483" "6979090" "7001032" "7005974" "7025469" "7038577" "7097312" "7106392" "7126456" "7167294" "7168830" "7184190" "7195381" "7249860" "7255451" "7267448" "7274501" "7289037" "7338177" "7339149" "7345680" "7370983" "7377675" "7391563" "7400435" "7420756" "7423522" "7492281" "7526103" "7581859" "7626749" "7636188" "7857469" "7934843" "8267534" "8562157" "D297926" "D493131" "D493394" "RE17274") .pn.	US- PGPUB; USPAT	ADJ	ON	2013/12/05 14:53
S15	385	S13 or S14	US- PGPUB; USPAT	ADJ	ON	2013/12/05 14:53

S16	130	S15 and (plano or planar) and (curv\$ or non? plano or non?planar)	US-PGPUB; USPAT	ADJ	ON	2013/12/05 14:53
S17	4	13/776,247.app. or 13/776,091.app.	US-PGPUB; USPAT	ADJ	ON	2013/12/05 15:09
S18	12	13/590,854.app. or 13/336,018.app. or 12/911,274.app. or 12/851,045.app. or 12/197,666.app. or 10/709,434.app.	US-PGPUB; USPAT	ADJ	ON	2013/12/05 15:11
S19	8	S18 and overlap\$	US-PGPUB; USPAT	ADJ	ON	2013/12/05 15:11
S20	2	12/197,666.app.	US-PGPUB; USPAT	ADJ	ON	2013/12/05 15:13
S21	16	13/776,247.app. or 13/776,091.app. or 13/590,854.app. or 13/336,018.app. or 12/911,274.app. or 12/851,045.app. or 12/197,666.app. or 10/709,434.app.	US-PGPUB; USPAT	ADJ	ON	2013/12/05 15:24
S24	1	"20020072026".pn.	US-PGPUB; USPAT	ADJ	ON	2013/12/05 15:30
S25	16	S21 and auxilliary	US-PGPUB; USPAT	ADJ	ON	2013/12/05 15:51
S26	4536	248/466-498.ccls.	US-PGPUB; USPAT	ADJ	ON	2013/12/05 21:01
S27	1266	S26 and (vehicle or automobile or car or truck or van)	US-PGPUB; USPAT	ADJ	ON	2013/12/05 21:02
S28	91	S27 and (plano or planar) and (curv\$ or non? plano or non?planar)	US-PGPUB; USPAT	ADJ	ON	2013/12/05 21:02
S29	75	(US-20030039039-\$ or US-20020105741-\$ or US-20130188237-\$ or US-20120314316-\$ or US-20110170207-\$ or US-20110157732-\$ or US-20100296187-\$ or US-20100195228-\$ or US-20090268321-\$ or US-20090237820-\$ or US-20090040306-\$ or US-20080308219-\$ or US-20080304170-\$ or US-20080225421-\$ or US-20080212189-\$ or US-20060279863-\$ or US-20060268440-\$ or US-20040264011-\$ or US-20040257685-\$ or US-20040165291-\$ or US-20040114260-\$ or US-20030117731-\$ or US-20030031023-\$ or US-20030026012-\$ or US-20020072026-\$ or US-20090115631-\$).did. or (US-20050248859-\$).did. or (US-6522451-\$ or US-5579133-\$ or US-4331382-\$ or US-8562157-\$ or US-7934843-\$ or US-7626749-\$ or US-7420756-\$ or US-7097312-\$ or US-6717712-\$ or US-8267534-\$ or US-7857469-\$ or US-7636188-\$ or US-7391563-\$ or US-7167294-\$ or US-7255451-\$ or US-7126456-\$ or US-7001032-\$ or US-6919796-\$ or US-6511192-\$ or US-6398377-\$ or US-6343402-\$ or US-6315419-\$ or US-6199993-\$ or US-5847889-\$ or US-5793542-\$ or US-5790327-\$).did. or (US-5784211-\$ or US-5296973-\$ or US-5295021-\$ or US-5166833-\$	US-PGPUB; USPAT	ADJ	ON	2013/12/05 21:03

		or US-5085907-\$ or US-5005962-\$ or US-4906075-\$ or US-D297926-\$ or US-4715701-\$ or US-4549786-\$ or US-4526446-\$ or US-4311363-\$ or US-4303308-\$ or US-4293191-\$ or US-4268120-\$ or US-4223983-\$ or US-4200359-\$ or US-3408136-\$ or US-3389952-\$ or US-3375053-\$ or US-2911177-\$ or US-1114559-\$).did.				
S30	27	S29 and overlap\$	US-PGPUB; USPAT	ADJ	ON	2013/12/05 21:04
S31	23	S30 and (plano or planar) and (curv\$ or non?plano or non?planar)	US-PGPUB; USPAT	ADJ	ON	2013/12/05 21:04
S32	248	("1114559" "1672559" "2135262" "2263382" "2279751" "2514989" "2580014" "2636419" "2778273" "2890539" "2911177" "20020036828" "20020048100" "20020072026" "20020105741" "20020159169" "20020159270" "20030026009" "20030026012" "20030031023" "20030043589" "20030117731" "20040032638" "20040032675" "20040032676" "20040114260" "20040165291" "20040257685" "20040264011" "20050078389" "20050083577" "20050099693" "20050134983" "20050232469" "20050248859" "20060050018" "20060061008" "20060125919" "20060126150" "20060171704" "20060184297" "20060268440" "20060279863" "20070058257" "20070285789" "20080212189" "20080225421" "20080304170" "20080308219" "20090040306" "20090115631" "20090237820" "20090268321" "20100195228" "20100296187" "20110157732" "20110170207" "20120314316" "20130188237" "20130188269" "3104274" "3131250" "3146296" "3170985" "3175463" "3266016" "3267806" "3280701" "3337285" "3338655" "3375053" "3389952" "3404935" "3408136" "3424517" "3563638" "3601614" "3610739" "3667833" "3708222" "3759647" "3764201" "3773882" "3806232" "3826563" "3881811" "3884606" "3909117" "4193668" "4200359" "4223983" "4258979" "4264144" "4268120" "4281899" "4293191" "4303308" "4306770" "4311362" "4311363" "4325609" "4331382" "4350412" "4385804" "4435042" "4436371" "4436372" "4439013" "4449786" "4470665" "4499451" "4526446" "4549786" "4555166" "4575202" "4588267" "4609266" "4623222" "4629296" "4630904" "4666264" "4674849" "4674850" "4678294"	US-PGPUB; USPAT	ADJ	ON	2013/12/05 21:04

		"4679906" "4712879" "4715701"				
		"4721364" "4727302" "4733336"				
		"4737188" "4770522" "4773740"				
		"4793690" "4799768" "4824231"				
		"4826289" "4828379" "4853283"				
		"4859046" "4882466" "4882565"				
		"4906075" "4906085" "4913542"				
		"4917485" "4929074" "4932769"				
		"4932770" "4944581" "4948242"				
		"4989964" "5005962" "5014167"				
		"5022747" "5033835" "5044739"				
		"5050977" "5052792" "5066112"				
		"5073012" "5076673" "5078480"				
		"5080492" "5085907" "5107374"				
		"5115346" "5115352" "5117346"				
		"5118540" "5140455" "5142407"				
		"5151816" "5151824" "5166833"				
		"5178448" "5179471" "5183099"				
		"5189537" "5193029" "5207492"				
		"5225943" "5233461" "5237458"				
		"5237459" "5239405" "5247395"				
		"5253109" "5262894" "5285060"				
		"5295021" "5296973" "5313335"				
		"5327288" "5354965" "5355245"				
		"5361172" "5371659" "5406414"				
		"5412512" "5424875" "5432643"				
		"5437931" "5446576" "5481409"				
		"5483386" "5497305" "5497306"				
		"5509606" "5517367" "5523877"				
		"5525264" "5526195" "5530588"				
		"5535056" "5550677" "5557467"				
		"5559640" "5563744" "5567360"				
		"5575552" "5579133" "5587236"				
		"5587699" "5594222" "5594593"				
		"5610756" "5621569" "5621577"				
		"5644442" "5649756" "5668663"				
		"5669698" "5669699" "5669704"				
		"5669705" "5670935" "5689370"				
		"5691855" "5715093" "5722836"				
		"5724187" "5751489" "5760962"				
		"5784211" "5786772" "5788357"				
		"5790298") FN.				
S33	137	("5790327" "5793542" "5796094"	US-	ADJ	ON	2013/12/05
		"5796532" "5805367" "5808777"	PGPUB;			21:04
		"5823654" "5825527" "5835294"	USPAT			
		"5838505" "5847889" "5863116"				
		"5864434" "5877897" "5910854"				
		"5922176" "5929786" "5938320"				
		"5980050" "6001486" "6002511"				
		"6005724" "6007207" "6030084"				
		"6032323" "6033078" "6065840"				
		"6074068" "6097023" "6109586"				
		"6111684" "6116743" "6124647"				
		"6128860" "6154306" "6164564"				
		"6172613" "6176602" "6178034"				
		"6196688" "6198409" "6199993"				
		"6201642" "6207083" "6227689"				
		"6245262" "6250148" "6257746"				
		"6260608" "6270225" "6276821"				
		"6286965" "6294989" "6310611"				
		"6315419" "6318870" "6320282"				
		"6329925" "6341523" "6343402"				
		"6356376" "6390632" "6396397"				
		"6398377" "6409354" "6420036"				

		"6428172" "6441964" "6445287" "6449082" "6472979" "6498620" "6501387" "6511192" "6512624" "6522451" "6537138" "6582109" "6595649" "6615438" "6627918" "6642851" "6648477" "6669109" "6690268" "6709119" "6717610" "6717712" "6719215" "6731205" "6737629" "6742904" "6757109" "6824281" "6831268" "6882287" "6919796" "6932483" "6979090" "7001032" "7005974" "7025469" "7038577" "7097312" "7106392" "7126456" "7167294" "7168830" "7184190" "7195381" "7249860" "7255451" "7267448" "7274501" "7289037" "7338177" "7339149" "7345680" "7370983" "7377675" "7391563" "7400435" "7420756" "7423522" "7492281" "7526103" "7581859" "7626749" "7636188" "7857469" "7934843" "8267534" "8562157" "D297926" "D493131" "D493394" "RE17274").pn.				
S34	385	S32 or S33	US- PGPUB; USPAT	ADJ	ON	2013/12/05 21:04
S35	89	S34 and overlap\$	US- PGPUB; USPAT	ADJ	ON	2013/12/05 21:05
S36	52	S35 and (plano or planar) and (curv\$ or non? plano or non?planar)	US- PGPUB; USPAT	ADJ	ON	2013/12/05 21:05
S37	16	13/776,247.app. or 13/776,091.app. or 13/590,854.app. or 13/336,018.app. or 12/911,274.app. or 12/851,045.app. or 12/197,666.app. or 10/709,434.app.	US- PGPUB; USPAT	ADJ	ON	2013/12/05 21:08
S38	6	S37 and overlap\$.clm.	US- PGPUB; USPAT	ADJ	ON	2013/12/05 21:08

12/ 5/ 2013 9:32:28 PM

C:\Users\kkakalec\Documents\EAST\Workspaces\14054004.wsp

<i>Index of Claims</i> 	Application/Control No. 14054004	Applicant(s)/Patent Under Reexamination LYNAM, NIALL R.
	Examiner KIMBERLY N KAKALEC	Art Unit 2872

✓	Rejected
=	Allowed

-	Cancelled
÷	Restricted

N	Non-Elected
I	Interference

A	Appeal
O	Objected

Claims renumbered in the same order as presented by applicant
 CPA
 T.D.
 R.1.47

CLAIM		DATE							
Final	Original	12/05/2013							
	1	✓							
	2	✓							
	3	✓							
	4	✓							
	5	✓							
	6	✓							
	7	✓							
	8	✓							
	9	✓							
	10	✓							
	11	✓							
	12	✓							
	13	✓							
	14	✓							
	15	✓							
	16	✓							
	17	✓							
	18	✓							
	19	✓							
	20	✓							



UNITED STATES PATENT AND TRADEMARK OFFICE

UNITED STATES DEPARTMENT OF COMMERCE
 United States Patent and Trademark Office
 Address: COMMISSIONER FOR PATENTS
 P.O. Box 1450
 Alexandria, Virginia 22313-1450
 www.uspto.gov

BIB DATA SHEET

CONFIRMATION NO. 4390

SERIAL NUMBER	FILING or 371(c) DATE	CLASS	GROUP ART UNIT	ATTORNEY DOCKET NO.		
14/054,004	10/15/2013	359	2872	DON09 P-2194		
APPLICANTS Donnelly Corporation, Holland, MI, Assignee (with 37 CFR 1.172 Interest); INVENTORS Niall R. Lynam, Holland, MI; ** CONTINUING DATA ***** This application is a CON of 13/776,247 02/25/2013 PAT 8562157 and is a CON of 13/776,091 02/25/2013 PAT 8591047 which is a CON of 13/590,854 08/21/2012 PAT 8550642 which is a CON of 13/336,018 12/23/2011 PAT 8267534 which is a CON of 12/911,274 10/25/2010 PAT 8128243 which is a CON of 12/851,045 08/05/2010 PAT 7934843 which is a CON of 12/197,666 08/25/2008 PAT 7842154 which is a DIV of 10/709,434 05/05/2004 PAT 7420756 which claims benefit of 60/471,872 05/20/2003 ** FOREIGN APPLICATIONS ***** ** IF REQUIRED, FOREIGN FILING LICENSE GRANTED ** 10/28/2013						
Foreign Priority claimed <input type="checkbox"/> Yes <input checked="" type="checkbox"/> No	35 USC 119(a-d) conditions met <input type="checkbox"/> Yes <input checked="" type="checkbox"/> No	<input type="checkbox"/> Met after Allowance	STATE OR COUNTRY	SHEETS DRAWINGS	TOTAL CLAIMS	INDEPENDENT CLAIMS
Verified and /KIMBERLY N KAKALEC/ Acknowledged _____ Examiner's Signature	_____	Initials	MI	19	20	3
ADDRESS						
Gardner, Linn, Burkhart & Flory, LLP 2851 Charlevoix Dr., SE, Suite 207 Grand Rapids, MI 49546 UNITED STATES						
TITLE						
EXTENDED FIELD OF VIEW EXTERIOR MIRROR ELEMENT FOR VEHICLE						
FILING FEE RECEIVED 1600	FEES: Authority has been given in Paper No. _____ to charge/credit DEPOSIT ACCOUNT No. _____ for following:		<input type="checkbox"/> All Fees <input type="checkbox"/> 1.16 Fees (Filing) <input type="checkbox"/> 1.17 Fees (Processing Ext. of time) <input type="checkbox"/> 1.18 Fees (Issue) <input type="checkbox"/> Other _____ <input type="checkbox"/> Credit			

Receipt date: 11/18/2013

14054004 - GAU: 2872

PTO/SB/08A (07-05)

Approved for use through 07/31/2006. OMB 0651-0031
U.S. Patent and Trademark Office; U.S. DEPARTMENT OF COMMERCE

Under the Paperwork Reduction Act of 1995, no persons are required to respond to a collection of information unless it contains a valid OMB control number.

Substitute for form 1449/PTO				Complete if Known	
INFORMATION DISCLOSURE STATEMENT BY APPLICANT <i>(Use as many sheets as necessary)</i>				Application Number	14/054,004
				Filing Date	October 15, 2013
				First Named Inventor	Niall R. Lynam
				Art Unit	2853
				Examiner Name	Alessandro V. Amari
				Attorney Docket Number	DON09 P-2194
Sheet	1	of	13		

U. S. PATENT DOCUMENTS					
Examiner Initials*	Cite No. ¹	Document Number	Publication Date MM-DD-YYYY	Name of Patentee or Applicant of Cited Document	Pages, Columns, Lines, Where Relevant Passages or Relevant Figures Appear
		Number-Kind Code ² (If Known)			

		8,562,157	2013-10-22	Lynam	
		8,267,534	2012-09-18	Lynam	
		7,934,843	2011-05-03	Lynam	
		7,857,469	2010-12-28	Sinelli et al.	
		7,636,188	2009-12-22	Baur et al.	
		7,626,749	2009-12-01	Baur et al.	
		7,581,859	2009-09-01	Lynam	
		7,526,103	2009-04-28	Schofield et al.	
		7,492,281	2009-02-17	Lynam et al.	
		7,423,522	2008-09-09	O'Brien et al.	
		7,420,756	2008-09-02	Lynam	
		7,400,435	2008-07-15	Byers et al.	
		7,391,563	2008-06-24	McCabe et al.	
		7,377,675	2008-05-27	Pastrick et al.	
		7,370,983	2008-05-13	DeWind et al.	
		7,345,680	2008-03-18	David	
		7,339,149	2008-03-04	Schofield et al.	
		7,338,177	2008-03-04	Lynam	
		7,289,037	2007-10-30	Uken et al.	
		7,274,501	2007-09-25	McCabe et al.	
		7,267,448	2007-09-11	Schmidt et al.	
		7,255,451	2007-08-14	McCabe et al.	
		7,249,860	2007-07-31	Kulas et al.	
		7,195,381	2007-03-27	Lynam et al.	
		7,184,190	2007-02-27	McCabe et al.	
		7,168,830	2007-01-30	Pastrick et al.	
		7,167,294	2007-01-23	Lynam et al.	
		7,126,456	2006-10-24	Boddy et al.	
		7,106,392	2006-09-12	You	
		7,097,312	2006-08-29	Platzer, Jr.	
		7,038,577	2006-05-02	Pawlicki et al.	
		7,025,469	2006-04-11	Manfre' et al.	
		7,005,974	2006-02-28	McMahon et al.	
		7,001,032	2006-02-21	Lo	

Examiner Signature	/Kimberly Kakalec/	Date Considered	12/05/2013
--------------------	--------------------	-----------------	------------

*EXAMINER: Initial if reference considered, whether or not citation is in conformance with MPEP 609. Draw line through citation if not in conformance and not considered. Include copy of this form with next communication to applicant. ¹ Applicant's unique citation designation number (optional). ² See Kinds Codes of USPTO Patent Documents at www.uspto.gov or MPEP 901.04. ³ Enter Office that issued the document, by the two-letter code (WIPO Standard ST.3). ⁴ For Japanese patent documents, the indication of the year of the reign of the Emperor must precede the serial number of the patent document. ⁵ Kind of document by the appropriate symbols as indicated on the document under WIPO Standard ST.16 if possible. ⁶ Applicant is to place a check mark here if English language Translation is attached.

This collection of information is required by 37 CFR 1.97 and 1.98. The information is required to obtain or retain a benefit by the public which is filed and by the USPTO to process an application. Confidentiality is not guaranteed. All references considered except where lined through. /K.K./

Confidentiality is not guaranteed. All references considered except where lined through. /K.K./

Commissioner for Patents, P.O. Box 1450, Alexandria, VA 22313-1450. DO NOT SEND FEES OR COMPLETED FORMS TO THIS ADDRESS. SEND TO:

Receipt date: 11/18/2013

14054004 (CAU): 2872

Approved for use through 07/31/2008 OMB 0367-0033
 U.S. Patent and Trademark Office; U.S. DEPARTMENT OF COMMERCE

Under the Paperwork Reduction Act of 1995, no persons are required to respond to a collection of information unless it contains a valid OMB control number.

Substitute for form 1449/PTO		INFORMATION DISCLOSURE STATEMENT BY APPLICANT <i>(Use as many sheets as necessary)</i>		Complete if Known	
				Application Number	14/054,004
		Filing Date	October 15, 2013		
		First Named Inventor	Niall R. Lynam		
		Art Unit	2853		
		Examiner Name	Alessandro V. Amari		
Sheet	2	of	13	Attorney Docket Number	DON09 P-2194

U. S. PATENT DOCUMENTS					
Examiner Initials*	Cite No. ¹	Document Number	Publication Date MM-DD-YYYY	Name of Patentee or Applicant of Cited Document	Pages, Columns, Lines, Where Relevant Passages or Relevant Figures Appear
		Number-Kind Code ² (If Known)			

		6,979,090	2005-12-27	Wnuk	
		6,932,483	2005-08-23	Strumolo et al.	
		6,919,796	2005-07-19	Boddy et al.	
		6,882,287	2005-04-19	Schofield	
		6,831,268	2004-12-14	Bechtel et al.	
		6,824,281	2004-11-30	Schofield et al.	
		6,757,109	2004-06-29	Bos	
		6,742,904	2004-06-01	Bechtel et al.	
		6,737,629	2004-05-18	Nixon et al.	
		6,731,205	2004-05-04	Schofield et al.	
		6,719,215	2004-04-13	Drouillard	
		6,717,712	2004-04-06	Lynam et al.	
		6,717,610	2004-04-06	Bos et al.	
		6,709,119	2004-03-23	Gillich et al.	
		6,690,268	2004-02-10	Schofield et al.	
		6,669,109	2003-12-30	Ivanov et al.	
		6,648,477	2003-11-18	Hutzel et al.	
		6,642,851	2003-11-04	DeLine et al.	
		6,627,918	2003-09-30	Getz et al.	
		6,615,438	2003-09-09	Franco	
		6,595,649	2003-07-22	Hoekstra et al.	
		6,582,109	2003-06-24	Miller	
		6,537,138	2003-03-25	Ohmori et al.	
		6,522,451	2003-02-18	Lynam	
		6,512,624	2003-01-28	Tonar et al.	
		6,511,192	2003-01-28	Henion et al.	
		6,501,387	2002-12-31	Skiver et al.	
		6,498,620	2002-12-24	Schofield et al.	
		6,472,979	2002-10-29	Schofield et al.	
		6,449,082	2002-09-10	Agrawal et al.	
		6,445,287	2002-09-03	Schofield et al.	
		6,441,964	2002-08-27	Chu et al.	
		6,428,172	2002-08-06	Hutzel et al.	
		6,420,036	2002-07-16	Varaprasad et al.	

Examiner Signature	/Kimberly Kakalec/	Date Considered	12/05/2013
--------------------	--------------------	-----------------	------------

*EXAMINER: Initial if reference considered, whether or not citation is in conformance with MPEP 609. Draw line through citation if not in conformance and not considered. Include copy of this form with next communication to applicant. ¹ Applicant's unique citation designation number (optional). ² See Kinds Codes of USPTO Patent Documents at www.uspto.gov or MPEP 901.04. ³ Enter Office that issued the document, by the two-letter code (WIPO Standard ST.3). ⁴ For Japanese patent documents, the indication of the year of the reign of the Emperor must precede the serial number of the patent document. ⁵ Kind of document by the appropriate symbols as indicated on the document under WIPO Standard ST.16 if possible. ⁶ Applicant is to place a check mark here if English language Translation is attached.

This collection of information is required by 37 CFR 1.97 and 1.98. The information is required to obtain or retain a benefit by the public which is filed and by the USPTO to process an application. Confidentiality is not guaranteed. All references considered except where lined through. /K.K./

Confidentiality is not guaranteed. All references considered except where lined through. /K.K./

form to the USPTO. Time will vary depending upon the individual case. Any comments on the amount of time you require to complete this form and/or suggestions for reducing this burden, should be sent to the Chief Information Officer, U.S. Patent and Trademark Office, P.O. Box 1450, Alexandria, VA 22313-1450. DO NOT SEND FEES OR COMPLETED FORMS TO THIS ADDRESS. SEND TO: Commissioner for Patents, P.O. Box 1450, Alexandria, VA 22313-1450.

Receipt date: 11/18/2013

14054004 (CAU): 2872

Approved for use through 07/31/2008 OMB 0357-0033
 U.S. Patent and Trademark Office; U.S. DEPARTMENT OF COMMERCE

Under the Paperwork Reduction Act of 1995, no persons are required to respond to a collection of information unless it contains a valid OMB control number.

Substitute for form 1449/PTO		Complete if Known	
INFORMATION DISCLOSURE STATEMENT BY APPLICANT <i>(Use as many sheets as necessary)</i>		Application Number	14/054,004
		Filing Date	October 15, 2013
		First Named Inventor	Niall R. Lynam
		Art Unit	2853
		Examiner Name	Alessandro V. Amari
		Attorney Docket Number	DON09 P-2194
Sheet	3	of	13

U. S. PATENT DOCUMENTS					
Examiner Initials*	Cite No. ¹	Document Number	Publication Date MM-DD-YYYY	Name of Patentee or Applicant of Cited Document	Pages, Columns, Lines, Where Relevant Passages or Relevant Figures Appear
		Number-Kind Code ² (If Known)			

		6,409,354	2002-06-25	Richard	
		6,398,377	2002-06-04	Chou	
		6,396,397	2002-05-28	Bos et al.	
		6,390,632	2002-05-21	Palathingal	
		6,356,376	2002-03-12	Tonar et al.	
		6,343,402	2002-02-05	Smith et al.	
		6,341,523	2002-01-29	Lynam	
		6,329,925	2001-12-11	Skiver et al.	
		6,320,282	2001-11-20	Caldwell	
		6,318,870	2001-11-20	Spooner et al.	
		6,315,419	2001-11-13	Platzer, Jr.	
		6,310,611	2001-10-30	Caldwell	
		6,294,989	2001-09-25	Schofield et al.	
		6,286,965	2001-09-11	Caskey et al.	
		6,276,821	2001-08-21	Pastrick et al.	
		6,270,225	2001-08-07	Goolsby	
		6,260,608	2001-07-17	Kim	
		6,257,746	2001-07-10	Todd et al.	
		6,250,148	2001-06-26	Lynam	
		6,245,262	2001-06-12	Varaprasad et al.	
		6,227,689	2001-05-08	Miller	
		6,207,083	2001-03-27	Varaprasad et al.	
		6,201,642	2001-03-13	Bos	
		6,199,993	2001-03-13	Mou	
		6,198,409	2001-03-06	Schofield et al.	
		6,196,688	2001-03-06	Caskey et al.	
		6,178,034	2001-01-23	Allemand et al.	
		6,176,602	2001-01-23	Pastrick et al.	
		6,172,613	2001-01-09	DeLine et al.	
		6,164,564	2000-12-26	Franco et al.	
		6,154,306	2000-11-28	Varaprasad et al.	
		6,315,419	2001-11-13	Platzer, Jr.	
		6,128,860	2000-10-10	Repp	
		6,124,647	2000-09-26	Marcus et al.	

Examiner Signature	/Kimberly Kakalec/	Date Considered	12/05/2013
--------------------	--------------------	-----------------	------------

*EXAMINER: Initial if reference considered, whether or not citation is in conformance with MPEP 609. Draw line through citation if not in conformance and not considered. Include copy of this form with next communication to applicant. ¹ Applicant's unique citation designation number (optional). ² See Kinds Codes of USPTO Patent Documents at www.uspto.gov or MPEP 901.04. ³ Enter Office that issued the document, by the two-letter code (WIPO Standard ST.3). ⁴ For Japanese patent documents, the indication of the year of the reign of the Emperor must precede the serial number of the patent document. ⁵ Kind of document by the appropriate symbols as indicated on the document under WIPO Standard ST.16 if possible. ⁶ Applicant is to place a check mark here if English language Translation is attached.

This collection of information is required by 37 CFR 1.97 and 1.98. The information is required to obtain or retain a benefit by the public which is filed by the USPTO to process an application. Confidentiality is not guaranteed. All references considered except where lined through. /K.K./

Confidentiality is not guaranteed. All references considered except where lined through. /K.K./

form to the USPTO. Time will vary depending upon the individual case. Any comments on the amount of time you require to complete this form and/or suggestions for reducing this burden, should be sent to the Chief Information Officer, U.S. Patent and Trademark Office, P.O. Box 1450, Alexandria, VA 22313-1450. DO NOT SEND FEES OR COMPLETED FORMS TO THIS ADDRESS. SEND TO: Commissioner for Patents, P.O. Box 1450, Alexandria, VA 22313-1450.

Receipt date: 11/18/2013

14054004 (CAU): 2872

Approved for use through 07/31/2008 OMB 0367-0034
 U.S. Patent and Trademark Office; U.S. DEPARTMENT OF COMMERCE

Under the Paperwork Reduction Act of 1995, no persons are required to respond to a collection of information unless it contains a valid OMB control number.

Substitute for form 1449/PTO		Complete if Known	
INFORMATION DISCLOSURE STATEMENT BY APPLICANT <i>(Use as many sheets as necessary)</i>		Application Number	14/054,004
		Filing Date	October 15, 2013
		First Named Inventor	Niall R. Lynam
		Art Unit	2853
		Examiner Name	Alessandro V. Amari
		Attorney Docket Number	DON09 P-2194
Sheet	4	of	13

U. S. PATENT DOCUMENTS					
Examiner Initials*	Cite No. ¹	Document Number	Publication Date MM-DD-YYYY	Name of Patentee or Applicant of Cited Document	Pages, Columns, Lines, Where Relevant Passages or Relevant Figures Appear
		Number-Kind Code ² (If Known)			

		6,116,743	2000-09-12	Hoek	
		6,111,684	2000-08-29	Forgette et al.	
		6,109,586	2000-08-29	Hock	
		6,097,023	2000-08-01	Schofield et al.	
		6,074,068	2000-06-13	Palathingal	
		6,065,840	2000-05-23	Caskey et al.	
		6,033,078	2000-03-07	Su et al.	
		6,032,323	2000-03-07	Smith et al.	
		6,030,084	2002-02-29	Schmidt	
		6,002,511	1999-12-14	Varaprasad et al.	
		6,001,486	1999-12-14	Varaprasad et al.	
		6,007,207	1999-12-28	Liu	
		6,005,724	1999-12-21	Todd	
		5,980,050	1999-11-09	McCord	
		5,938,320	1999-08-17	Crandall	
		5,929,786	1999-07-27	Schofield et al.	
		5,922,176	1999-07-13	Caskey	
		5,910,854	1999-06-08	Varaprasad et al.	
		5,877,897	1999-03-02	Schofield et al.	
		5,864,434	1999-01-26	Taylor	
		5,863,116	1999-01-26	Pastrick et al.	
		5,847,889	1998-12-08	Komiyama et al.	
		5,838,505	1998-11-17	Palathingal	
		5,835,294	1998-11-10	Minegishi	
		5,825,527	1998-10-20	Forgette et al.	
		5,823,654	1998-10-20	Pastrick et al.	
		5,808,777	1998-09-15	Lynam et al.	
		5,805,367	1998-09-08	Kanazawa	
		5,796,532	1998-08-18	Kanazawa	
		5,796,094	1998-08-18	Schofield et al.	
		5,793,542	1998-08-11	Kondo et al.	
		5,790,327	1998-08-04	Lee et al.	
		5,790,298	1998-08-04	Tonar	
		5,788,357	1998-08-04	Muth et al.	

Examiner Signature	/Kimberly Kakalec/	Date Considered	12/05/2013
--------------------	--------------------	-----------------	------------

*EXAMINER: Initial if reference considered, whether or not citation is in conformance with MPEP 609. Draw line through citation if not in conformance and not considered. Include copy of this form with next communication to applicant. ¹ Applicant's unique citation designation number (optional). ² See Kinds Codes of USPTO Patent Documents at www.uspto.gov or MPEP 901.04. ³ Enter Office that issued the document, by the two-letter code (WIPO Standard ST.3). ⁴ For Japanese patent documents, the indication of the year of the reign of the Emperor must precede the serial number of the patent document. ⁵ Kind of document by the appropriate symbols as indicated on the document under WIPO Standard ST.16 if possible. ⁶ Applicant is to place a check mark here if English language Translation is attached.

This collection of information is required by 37 CFR 1.97 and 1.98. The information is required to obtain or retain a benefit by the public which is filed by the USPTO to process an application. Confidentiality is not guaranteed. All references considered except where lined through. /K.K./
 Confidentiality is not guaranteed. All references considered except where lined through. /K.K./
 form to the USPTO. Time will vary depending upon the individual case. Any comments on the amount of time you require to complete this form and/or suggestions for reducing this burden, should be sent to the Chief Information Officer, U.S. Patent and Trademark Office, P.O. Box 1450, Alexandria, VA 22313-1450. DO NOT SEND FEES OR COMPLETED FORMS TO THIS ADDRESS. SEND TO: Commissioner for Patents, P.O. Box 1450, Alexandria, VA 22313-1450.

Receipt date: 11/18/2013

14054004 (CAU): 2872

Approved for use through 07/31/2008 OMB 0367-0033
 U.S. Patent and Trademark Office; U.S. DEPARTMENT OF COMMERCE

Under the Paperwork Reduction Act of 1995, no persons are required to respond to a collection of information unless it contains a valid OMB control number.

Substitute for form 1449/PTO		INFORMATION DISCLOSURE STATEMENT BY APPLICANT <i>(Use as many sheets as necessary)</i>		Complete if Known	
				Application Number	14/054,004
		Filing Date	October 15, 2013		
		First Named Inventor	Niall R. Lynam		
		Art Unit	2853		
		Examiner Name	Alessandro V. Amari		
Sheet	5	of	13	Attorney Docket Number	DON09 P-2194

U. S. PATENT DOCUMENTS					
Examiner Initials*	Cite No. ¹	Document Number	Publication Date MM-DD-YYYY	Name of Patentee or Applicant of Cited Document	Pages, Columns, Lines, Where Relevant Passages or Relevant Figures Appear
		Number-Kind Code ² (if known)			

		5,786,772	1998-07-28	Schofield et al.	
		5,784,211	1998-07-21	Mingledorff	
		5,760,962	1998-06-02	Schofield et al.	
		5,751,489	1998-05-12	Caskey et al.	
		5,724,187	1998-03-03	Varaprasad et al.	
		5,722,836	1998-03-03	Yunker	
		5,715,093	1998-02-03	Schierbeek et al.	
		5,691,855	1997-11-25	Lupkas	
		5,689,370	1997-11-18	Tonar et al.	
		5,670,935	1997-09-23	Schofield et al.	
		5,669,705	1997-09-23	Pastrick et al.	
		5,669,704	1997-09-23	Pastrick	
		5,669,699	1997-09-23	Pastrick et al.	
		5,669,698	1997-09-23	Veldman et al.	
		5,668,663	1997-09-16	Varaprasad et al.	
		5,649,756	1997-07-22	Adams et al.	
		5,644,442	1997-07-01	Lemere	
		5,621,577	1997-04-15	Lang et al.	
		5,621,569	1997-04-15	Schlenke	
		5,610,756	1997-03-11	Lynam et al.	
		5,594,593	1997-01-14	Milner	
		5,594,222	1997-01-14	Caldwell	
		5,587,699	1996-12-24	Faloon et al.	
		5,587,236	1996-12-24	Agrawal et al.	
		5,579,133	1996-11-26	Black et al.	
		5,575,552	1996-11-19	Faloon et al.	
		5,567,360	1996-10-22	Varaprasad et al.	
		5,563,744	1996-10-08	Matsumiya	
		5,559,640	1996-09-24	Vachss et al.	
		5,557,467	1996-09-17	McColgan et al.	
		5,550,677	1996-08-27	Schofield et al.	
		5,535,056	1996-07-09	Caskey et al.	
		5,530,588	1996-06-25	Vivier	
		5,526,195	1996-06-11	Thomas	

Examiner Signature	/Kimberly Kakalec/	Date Considered	12/05/2013
--------------------	--------------------	-----------------	------------

*EXAMINER: Initial if reference considered, whether or not citation is in conformance with MPEP 609. Draw line through citation if not in conformance and not considered. Include copy of this form with next communication to applicant. ¹ Applicant's unique citation designation number (optional). ² See Kinds Codes of USPTO Patent Documents at www.uspto.gov or MPEP 901.04. ³ Enter Office that issued the document, by the two-letter code (WIPO Standard ST.3). ⁴ For Japanese patent documents, the indication of the year of the reign of the Emperor must precede the serial number of the patent document. ⁵ Kind of document by the appropriate symbols as indicated on the document under WIPO Standard ST.16 if possible. ⁶ Applicant is to place a check mark here if English language Translation is attached.

This collection of information is required by 37 CFR 1.97 and 1.98. The information is required to obtain or retain a benefit by the public which is filed and by the USPTO to process an application. Confidentiality is not guaranteed. All references considered except where lined through. /K.K./
 Confidentiality is not guaranteed. All references considered except where lined through. /K.K./
 form to the USPTO. Time will vary depending upon the individual case. Any comments on the amount of time you require to complete this form and/or suggestions for reducing this burden, should be sent to the Chief Information Officer, U.S. Patent and Trademark Office, P.O. Box 1450, Alexandria, VA 22313-1450. DO NOT SEND FEES OR COMPLETED FORMS TO THIS ADDRESS. SEND TO: Commissioner for Patents, P.O. Box 1450, Alexandria, VA 22313-1450.

Receipt date: 11/18/2013

14054004 (CAU): 2872

Approved for use through 07/31/2008 OMB 0367-0134
 U.S. Patent and Trademark Office; U.S. DEPARTMENT OF COMMERCE

Under the Paperwork Reduction Act of 1995, no persons are required to respond to a collection of information unless it contains a valid OMB control number.

Substitute for form 1449/PTO		Complete if Known	
INFORMATION DISCLOSURE STATEMENT BY APPLICANT <i>(Use as many sheets as necessary)</i>		Filing Date	October 15, 2013
		First Named Inventor	Niall R. Lynam
		Art Unit	2853
		Examiner Name	Alessandro V. Amari
		Attorney Docket Number	DON09 P-2194
		Sheet	6

U. S. PATENT DOCUMENTS					
Examiner Initials*	Cite No. ¹	Document Number	Publication Date MM-DD-YYYY	Name of Patentee or Applicant of Cited Document	Pages, Columns, Lines, Where Relevant Passages or Relevant Figures Appear
		Number-Kind Code ² (If Known)			

		5,525,264	1996-06-11	Cronin et al.	
		5,523,877	1996-06-04	Lynam	
		5,517,367	1996-05-14	Kim et al.	
		5,509,606	1996-04-23	Breithaupt et al.	
		5,497,306	1996-03-05	Pastrick	
		5,497,305	1996-03-05	Pastrick et al.	
		5,483,386	1996-01-09	Carson	
		5,481,409	1996-01-02	Roberts	
		5,446,576	1995-08-29	Lynam et al.	
		5,437,931	1995-08-01	Tsai et al.	
		5,432,643	1995-07-11	Huang	
		5,424,875	1995-06-13	Davis, II	
		5,412,512	1995-05-02	Zebold et al.	
		5,406,414	1995-04-11	O'Farrell et al.	
		5,371,659	1994-12-06	Pastrick et al.	
		5,361,172	1994-11-01	Schissel et al.	
		5,355,245	1994-10-11	Lynam	
		5,354,965	1994-10-11	Lee	
		5,327,288	1994-07-05	Wellington et al.	
		5,313,335	1994-05-17	Gray et al.	
		5,296,973	1994-03-22	Burke	
		5,295,021	1994-03-15	Swanson	
		5,285,060	1994-02-08	Larson et al.	
		5,262,894	1993-11-16	Wheatley et al.	
		5,253,109	1993-10-12	O'Farrell et al.	
		5,247,395	1993-09-21	Martinez	
		5,239,405	1993-08-24	Varaprasad et al.	
		5,237,459	1993-08-17	Strauss	
		5,237,458	1993-08-17	Polanyi et al.	
		5,233,461	1993-08-03	Dornan et al.	
		5,225,943	1993-07-06	Lupo	
		5,207,492	1993-05-04	Roberts	
		5,193,029	1993-03-09	Schofield et al.	
		5,189,537	1993-02-23	O'Farrell	

Examiner Signature	/Kimberly Kakalec/	Date Considered	12/05/2013
--------------------	--------------------	-----------------	------------

*EXAMINER: Initial if reference considered, whether or not citation is in conformance with MPEP 609. Draw line through citation if not in conformance and not considered. Include copy of this form with next communication to applicant. ¹ Applicant's unique citation designation number (optional). ² See Kinds Codes of USPTO Patent Documents at www.uspto.gov or MPEP 901.04. ³ Enter Office that issued the document, by the two-letter code (WIPO Standard ST.3). ⁴ For Japanese patent documents, the indication of the year of the reign of the Emperor must precede the serial number of the patent document. ⁵ Kind of document by the appropriate symbols as indicated on the document under WIPO Standard ST.16 if possible. ⁶ Applicant is to place a check mark here if English language Translation is attached.

This collection of information is required by 37 CFR 1.97 and 1.98. The information is required to obtain or retain a benefit by the public which is filed by the USPTO to process an application. Confidentiality is not guaranteed. This information includes a patent number, title, inventor, and applicant. It is not to be used for any other purpose. If you have any questions, please contact the Chief Information Officer, U.S. Patent and Trademark Office, P.O. Box 1450, Alexandria, VA 22313-1450. DO NOT SEND FEES OR COMPLETED FORMS TO THIS ADDRESS. SEND TO: Commissioner for Patents, P.O. Box 1450, Alexandria, VA 22313-1450.

ALL REFERENCES CONSIDERED EXCEPT WHERE LINED THROUGH. /K.K./

Receipt date: 11/18/2013

14054004 (CAU): 2872

Approved for use through 07/31/2008 OMB 0367-0133
 U.S. Patent and Trademark Office; U.S. DEPARTMENT OF COMMERCE

Under the Paperwork Reduction Act of 1995, no persons are required to respond to a collection of information unless it contains a valid OMB control number.

Substitute for form 1449/PTO		Complete if Known	
INFORMATION DISCLOSURE STATEMENT BY APPLICANT <i>(Use as many sheets as necessary)</i>		Application Number	14/054,004
		Filing Date	October 15, 2013
		First Named Inventor	Niall R. Lynam
		Art Unit	2853
		Examiner Name	Alessandro V. Amari
		Attorney Docket Number	DON09 P-2194
Sheet	7	of	13

U. S. PATENT DOCUMENTS					
Examiner Initials*	Cite No. ¹	Document Number	Publication Date MM-DD-YYYY	Name of Patentee or Applicant of Cited Document	Pages, Columns, Lines, Where Relevant Passages or Relevant Figures Appear
		Number-Kind Code ² (if known)			

		5,183,099	1993-02-02	Bechu	
		5,179,471	1993-01-12	Caskey et al.	
		5,178,448	1993-01-12	Adams et al.	
		5,166,833	1992-11-24	Shyu	
		5,151,824	1992-09-29	O'Farrell	
		5,151,816	1992-09-29	Varaprasad et al.	
		5,142,407	1992-08-25	Varaprasad et al.	
		5,140,455	1992-08-18	Varaprasad et al.	
		5,118,540	1992-06-02	Hutchison	
		5,117,346	1992-05-26	Gard	
		5,115,352	1992-05-19	do Espirito Santo	
		5,115,346	1992-05-19	Lynam	
		5,107,374	1992-04-21	Lupo et al.	
		5,085,907	1992-02-04	Smith	
		5,080,492	1992-01-14	Platzer, Jr.	
		5,078,480	1992-01-07	Warszawski	
		5,076,673	1991-12-31	Lynam et al.	
		5,073,012	1991-12-17	Lynam	
		5,066,112	1991-11-19	Lynam et al.	
		5,052,792	1991-10-01	McDonough	
		5,050,977	1991-09-24	Platzer, Jr.	
		5,044,739	1991-09-03	do Espirito Santo	
		5,033,835	1991-07-23	Platzer, Jr.	
		5,022,747	1991-06-11	Polanyi et al.	
		5,014,167	1991-05-07	Roberts	
		5,005,962	1991-04-09	Edelman	
		4,989,964	1991-02-05	Meise	
		4,948,242	1990-08-14	Desmond et al.	
		4,944,581	1990-07-31	Ichikawa	
		4,932,770	1990-06-12	Caravaty	
		4,932,769	1990-06-12	Goosen	
		4,929,074	1990-05-29	Urban	
		4,917,485	1990-04-17	Baldwin, Sr.	
		4,913,542	1990-04-03	Adolfsson	

Examiner Signature	/Kimberly Kakalec/	Date Considered	12/05/2013
--------------------	--------------------	-----------------	------------

*EXAMINER: Initial if reference considered, whether or not citation is in conformance with MPEP 609. Draw line through citation if not in conformance and not considered. Include copy of this form with next communication to applicant. ¹ Applicant's unique citation designation number (optional). ² See Kinds Codes of USPTO Patent Documents at www.uspto.gov or MPEP 901.04. ³ Enter Office that issued the document, by the two-letter code (WIPO Standard ST.3). ⁴ For Japanese patent documents, the indication of the year of the reign of the Emperor must precede the serial number of the patent document. ⁵ Kind of document by the appropriate symbols as indicated on the document under WIPO Standard ST.16 if possible. ⁶ Applicant is to place a check mark here if English language Translation is attached.

This collection of information is required by 37 CFR 1.97 and 1.98. The information is required to obtain or retain a benefit by the public which is filed by the USPTO to process an application. Confidentiality is not guaranteed. All references considered except where lined through. /K.K./

Confidentiality is not guaranteed. All references considered except where lined through. /K.K./

form to the USPTO. Time will vary depending upon the individual case. Any comments on the amount of time you require to complete this form and/or suggestions for reducing this burden, should be sent to the Chief Information Officer, U.S. Patent and Trademark Office, P.O. Box 1450, Alexandria, VA 22313-1450. DO NOT SEND FEES OR COMPLETED FORMS TO THIS ADDRESS. SEND TO: Commissioner for Patents, P.O. Box 1450, Alexandria, VA 22313-1450.

Receipt date: 11/18/2013

14054004 (CAU): 2872

Approved for use through 07/31/2008 OMB 0357-0033
 U.S. Patent and Trademark Office; U.S. DEPARTMENT OF COMMERCE

Under the Paperwork Reduction Act of 1995, no persons are required to respond to a collection of information unless it contains a valid OMB control number.

Substitute for form 1449/PTO INFORMATION DISCLOSURE STATEMENT BY APPLICANT <i>(Use as many sheets as necessary)</i>		Complete if Known			
		Application Number	14/054,004		
		Filing Date	October 15, 2013		
		First Named Inventor	Niall R. Lynam		
		Art Unit	2853		
		Examiner Name	Alessandro V. Amari		
Sheet	8	of	13	Attorney Docket Number	DON09 P-2194

U. S. PATENT DOCUMENTS					
Examiner Initials*	Cite No. ¹	Document Number	Publication Date MM-DD-YYYY	Name of Patentee or Applicant of Cited Document	Pages, Columns, Lines, Where Relevant Passages or Relevant Figures Appear
		Number-Kind Code ² (If Known)			

		4,906,085	1990-03-06	Sugihara et al.	
		4,906,075	1990-03-06	Majsumiya	
		4,882,565	1989-11-21	Gallmeyer	
		4,882,466	1989-11-21	Friel	
		4,859,046	1989-08-22	Traynor et al.	
		4,853,283	1989-08-01	Skolnick	
		4,828,379	1989-05-09	Parsons et al.	
		4,826,289	1989-05-02	Vandenbrink et al.	
		4,824,231	1989-04-25	Quintana	
		4,799,768	1989-01-24	Gahan	
		4,793,690	1988-12-27	Gahan et al.	
		4,773,740	1988-09-27	Kawakami et al.	
		4,770,522	1988-09-13	Alten	
		4,737,188	1988-04-12	Bahls	
		4,733,336	1988-03-22	Skogler et al.	
		4,727,302	1988-02-23	Mizuta et al.	
		4,721,364	1988-01-26	Itoh et al.	
		4,715,701	1987-12-29	Urban	
		4,712,879	1987-12-15	Lynam et al.	
		4,679,906	1987-07-14	Brandenburg	
		4,678,294	1987-07-01	Van Nostrand	
		4,674,850	1987-06-23	Blom	
		4,674,849	1987-06-23	Stewart	
		4,666,264	1987-05-19	Yamabe	
		4,630,904	1986-12-23	Pastore	
		4,629,296	1986-12-16	White	
		4,623,222	1986-11-18	Itoh et al.	
		4,609,266	1986-09-02	Blom	
		4,588,267	1986-05-13	Pastore	
		4,575,202	1986-03-11	McGuire	
		4,555,166	1985-11-26	Enomoto	
		4,549,786	1985-10-29	Albers et al.	
		4,526,446	1985-07-02	Adams	
		4,499,451	1985-02-12	Suzuki et al.	

Examiner Signature	/Kimberly Kakalec/	Date Considered	12/05/2013
--------------------	--------------------	-----------------	------------

*EXAMINER: Initial if reference considered, whether or not citation is in conformance with MPEP 609. Draw line through citation if not in conformance and not considered. Include copy of this form with next communication to applicant. ¹ Applicant's unique citation designation number (optional). ² See Kinds Codes of USPTO Patent Documents at www.uspto.gov or MPEP 901.04. ³ Enter Office that issued the document, by the two-letter code (WIPO Standard ST.3). ⁴ For Japanese patent documents, the indication of the year of the reign of the Emperor must precede the serial number of the patent document. ⁵ Kind of document by the appropriate symbols as indicated on the document under WIPO Standard ST.16 if possible. ⁶ Applicant is to place a check mark here if English language Translation is attached.

This collection of information is required by 37 CFR 1.97 and 1.98. The information is required to obtain or retain a benefit by the public which is filed and by the USPTO to process an application. Confidentiality is not guaranteed. All references considered except where lined through. /K.K./

Confidentiality is not guaranteed. All references considered except where lined through. /K.K./

form to the USPTO. Time will vary depending upon the individual case. Any comments on the amount of time you require to complete this form and/or suggestions for reducing this burden, should be sent to the Chief Information Officer, U.S. Patent and Trademark Office, P.O. Box 1450, Alexandria, VA 22313-1450. DO NOT SEND FEES OR COMPLETED FORMS TO THIS ADDRESS. SEND TO: Commissioner for Patents, P.O. Box 1450, Alexandria, VA 22313-1450.

Receipt date: 11/18/2013

14054004 (CAU): 2872

Approved for use through 07/31/2008 OMB 0357-0034
 U.S. Patent and Trademark Office; U.S. DEPARTMENT OF COMMERCE

Under the Paperwork Reduction Act of 1995, no persons are required to respond to a collection of information unless it contains a valid OMB control number.

Substitute for form 1449/PTO		INFORMATION DISCLOSURE STATEMENT BY APPLICANT <i>(Use as many sheets as necessary)</i>		Complete if Known	
				Application Number	14/054,004
		Filing Date	October 15, 2013		
		First Named Inventor	Niall R. Lynam		
		Art Unit	2853		
		Examiner Name	Alessandro V. Amari		
Sheet	9	of	13	Attorney Docket Number	DON09 P-2194

U. S. PATENT DOCUMENTS					
Examiner Initials*	Cite No. ¹	Document Number	Publication Date MM-DD-YYYY	Name of Patentee or Applicant of Cited Document	Pages, Columns, Lines, Where Relevant Passages or Relevant Figures Appear
		Number-Kind Code ² (If Known)			

		4,470,665	1984-09-11	Blom	
		4,449,786	1984-05-22	McCord	
		4,439,013	1984-03-27	Hagn et al.	
		4,436,372	1984-03-13	Schmidt et al.	
		4,436,371	1984-03-13	Wood et al.	
		4,435,042	1984-03-06	Wood et al.	
		4,385,804	1983-05-31	Tamura et al.	
		4,350,412	1982-09-21	Steenblik et al.	
		4,331,382	1982-05-25	Graff	
		4,325,609	1982-04-20	Alford	
		4,311,363	1982-01-19	Marsalka et al.	
		4,311,362	1982-01-19	LaPorte	
		4,306,770	1981-12-22	Marhauer	
		4,303,308	1981-12-01	Kobrin	
		4,293,191	1981-10-06	Kim	
		4,281,899	1981-08-04	Oskam	
		4,268,120	1981-05-19	Jitsumori	
		4,264,144	1981-04-28	McCord	
		4,258,979	1981-03-31	Mahin	
		4,223,983	1980-09-23	Bloom	
		4,200,359	1980-04-29	Lawson	
		4,193,668	1980-03-18	Skinner	
		3,909,117	1975-09-30	Takahashi et al.	
		3,884,606	1975-05-20	Schrenk	
		3,881,811	1975-05-06	French	
		3,826,563	1974-07-30	Davis	
		3,806,232	1974-04-23	Gray	
		3,773,882	1973-11-20	Schrenk	
		3,764,201	1973-10-09	Haile	
		3,759,647	1973-09-18	Schrenk et al.	
		3,708,222	1973-01-02	Stern	
		3,667,833	1972-06-06	Baldwin, Sr.	
		3,610,739	1971-10-05	Seashore	
		3,601,614	1971-08-24	Platzer, Jr.	

Examiner Signature	/Kimberly Kakalec/	Date Considered	12/05/2013
--------------------	--------------------	-----------------	------------

*EXAMINER: Initial if reference considered, whether or not citation is in conformance with MPEP 609. Draw line through citation if not in conformance and not considered. Include copy of this form with next communication to applicant. ¹ Applicant's unique citation designation number (optional). ² See Kinds Codes of USPTO Patent Documents at www.uspto.gov or MPEP 901.04. ³ Enter Office that issued the document, by the two-letter code (WIPO Standard ST.3). ⁴ For Japanese patent documents, the indication of the year of the reign of the Emperor must precede the serial number of the patent document. ⁵ Kind of document by the appropriate symbols as indicated on the document under WIPO Standard ST.16 if possible. ⁶ Applicant is to place a check mark here if English language Translation is attached.

This collection of information is required by 37 CFR 1.97 and 1.98. The information is required to obtain or retain a benefit by the public which is filed and by the USPTO to process an application. Confidentiality of this information is not guaranteed. All references considered except where lined through. /K.K./

Confidentiality of this information is not guaranteed. All references considered except where lined through. /K.K./

form to the USPTO. Time will vary depending upon the individual case. Any comments on the amount of time you require to complete this form and/or suggestions for reducing this burden, should be sent to the Chief Information Officer, U.S. Patent and Trademark Office, P.O. Box 1450, Alexandria, VA 22313-1450. DO NOT SEND FEES OR COMPLETED FORMS TO THIS ADDRESS. SEND TO: Commissioner for Patents, P.O. Box 1450, Alexandria, VA 22313-1450.

Receipt date: 11/18/2013

14054004 (CAU): 2872

Approved for use through 07/31/2008 OMB 0357-0033
 U.S. Patent and Trademark Office; U.S. DEPARTMENT OF COMMERCE

Under the Paperwork Reduction Act of 1995, no persons are required to respond to a collection of information unless it contains a valid OMB control number.

Substitute for form 1449/PTO		Complete if Known	
INFORMATION DISCLOSURE STATEMENT BY APPLICANT <i>(Use as many sheets as necessary)</i>		Application Number	14/054,004
		Filing Date	October 15, 2013
		First Named Inventor	Niall R. Lynam
		Art Unit	2853
		Examiner Name	Alessandro V. Amari
		Attorney Docket Number	DON09 P-2194
Sheet	10	of	13

U. S. PATENT DOCUMENTS					
Examiner Initials*	Cite No. ¹	Document Number	Publication Date MM-DD-YYYY	Name of Patentee or Applicant of Cited Document	Pages, Columns, Lines, Where Relevant Passages or Relevant Figures Appear
		Number-Kind Code ² (If Known)			

		3,563,638	1971-02-16	Panozzo	
		3,424,517	1969-01-28	Budreck	
		3,408,136	1968-10-29	Travis	
		3,404,935	1968-10-08	Creager	
		3,389,952	1968-06-25	Tobin, Jr.	
		3,375,053	1968-03-26	Ward	
		3,338,655	1967-08-29	Young	
		3,337,285	1967-08-22	Travis	
		3,280,701	1966-10-25	Donnelly et al.	
		3,267,806	1966-08-23	Azegami	
		3,266,016	1966-08-09	Maruyama et al.	
		3,175,463	1965-03-30	Seashore	
		3,170,985	1965-02-23	Katulich	
		3,146,296	1964-08-25	Fischer	
		3,131,250	1964-04-28	Ely	
		3,104,274	1963-09-17	King	
		2,911,177	1959-11-03	West	
		2,890,539	1959-06-16	Holt	
		2,279,751	1942-04-14	Elwood	
		2,778,273	1957-01-22	Fellmeth	
		2,636,419	1953-04-28	Kerr	
		2,580,014	1951-12-25	Gazda	
		2,514,989	1950-07-11	Buren	
		2,263,382	1941-11-18	Gotzinger	
		2,135,262	1938-11-01	Schumacher	
		1,672,559	1928-06-05	Doble	
		1,114,559	1914-10-20	Weed	
		D297,926	1988-10-04	Kesler	
		D493,394	2004-07-27	Lawlor et al.	
		D493,131	2004-07-20	Lawlor et al.	
		2002/0036828	2002-03-28	Wong	
		2002/0048100	2002-04-25	Hoek	
		2002/0072026	2002-06-04	Lynam et al.	
		2002/0105741	2002-08-08	Platzer, Jr.	

Examiner Signature	/Kimberly Kakalec/	Date Considered	12/05/2013
--------------------	--------------------	-----------------	------------

*EXAMINER: Initial if reference considered, whether or not citation is in conformance with MPEP 609. Draw line through citation if not in conformance and not considered. Include copy of this form with next communication to applicant. ¹ Applicant's unique citation designation number (optional). ² See Kinds Codes of USPTO Patent Documents at www.uspto.gov or MPEP 901.04. ³ Enter Office that issued the document, by the two-letter code (WIPO Standard ST.3). ⁴ For Japanese patent documents, the indication of the year of the reign of the Emperor must precede the serial number of the patent document. ⁵ Kind of document by the appropriate symbols as indicated on the document under WIPO Standard ST.16 if possible. ⁶ Applicant is to place a check mark here if English language Translation is attached.

This collection of information is required by 37 CFR 1.97 and 1.98. The information is required to obtain or retain a benefit by the public which is filed and by the USPTO to process an application. Confidentiality is not guaranteed. All references considered except where lined through. /K.K./

Confidentiality is not guaranteed. All references considered except where lined through. /K.K./

form to the USPTO. Time will vary depending upon the individual case. Any comments on the amount of time you require to complete this form and/or suggestions for reducing this burden, should be sent to the Chief Information Officer, U.S. Patent and Trademark Office, P.O. Box 1450, Alexandria, VA 22313-1450. DO NOT SEND FEES OR COMPLETED FORMS TO THIS ADDRESS. SEND TO: Commissioner for Patents, P.O. Box 1450, Alexandria, VA 22313-1450.

Receipt date: 11/18/2013

14054004 (SAU): 2872

Approved for use through 07/31/2008. OMB 0957-0034
 U.S. Patent and Trademark Office; U.S. DEPARTMENT OF COMMERCE

Under the Paperwork Reduction Act of 1995, no persons are required to respond to a collection of information unless it contains a valid OMB control number.

Substitute for form 1449/PTO INFORMATION DISCLOSURE STATEMENT BY APPLICANT <i>(Use as many sheets as necessary)</i>		Complete if Known	
		Application Number	14/054,004
		Filing Date	October 15, 2013
		First Named Inventor	Niall R. Lynam
		Art Unit	2853
		Examiner Name	Alessandro V. Amari
Sheet	11	of	13
		Attorney Docket Number	DON09 P-2194

U. S. PATENT DOCUMENTS					
Examiner Initials*	Cite No. ¹	Document Number	Publication Date MM-DD-YYYY	Name of Patentee or Applicant of Cited Document	Pages, Columns, Lines, Where Relevant Passages or Relevant Figures Appear
		Number-Kind Code ² (If Known)			

		2002/0159169	2002-10-31	McCord	
		2002/0159270	2002-10-31	Lynam et al.	
		2003/0026009	2003-02-06	Vandenbrink	
		2003/0026012	2003-02-06	Pavao	
		2003/0031023	2003-02-13	Hutzel	
		2003/0043589	2003-03-06	Blank	
		2003/0117731	2003-06-26	Platzer, Jr.	
		2004/0032675	2004-02-19	Weller et al.	
		2004/0032638	2004-02-19	Tonar et al.	
		2004/0032676	2004-02-19	Drummond et al.	
		2004/0114260	2004-06-17	Bartnick	
		2004/0165291	2004-08-26	Platzer, Jr.	
		2004/0257685	2004-12-23	Minor et al.	
		2004/0264011	2004-12-30	Lynam	
		2005/0078389	2005-04-14	Kulas et al.	
		2005/0083577	2005-04-21	Varaprasad et al.	
		2005/0099693	2005-05-12	Schofield et al.	
		2005/0134983	2005-06-23	Lynam	
		2005/0232469	2005-10-20	Schofield et al.	
		2005/0248859	2005-11-10	Platzer, Jr.	
		2006/0050018	2006-03-09	Hutzel et al.	
		2006/0061008	2006-03-23	Karner et al.	
		2006/0125919	2006-06-15	Camilleri et al.	
		2006/0126150	2006-06-15	Tonar et al.	
		2006/0171704	2006-08-03	Bingle et al.	
		2006/0184297	2006-08-17	Higgins-Luthman	
		2006/0268440	2006-11-30	Platzer, Jr.	
		2006/0279863	2006-12-14	Starbuck	
		2007/0058257	2007-03-15	Lynam	
		2007/0285789	2007-12-13	Lindahl et al.	
		2008/0212189	2008-09-04	Baur et al.	
		2008/0225421	2008-09-18	Platzer	
		2008/0304170	2008-12-11	Zhao	
		2008/0308219	2008-12-18	Lynam	

Examiner Signature	/Kimberly Kakalec/	Date Considered	12/05/2013
--------------------	--------------------	-----------------	------------

*EXAMINER: Initial if reference considered, whether or not citation is in conformance with MPEP 609. Draw line through citation if not in conformance and not considered. Include copy of this form with next communication to applicant. ¹ Applicant's unique citation designation number (optional). ² See Kinds Codes of USPTO Patent Documents at www.uspto.gov or MPEP 901.04. ³ Enter Office that issued the document, by the two-letter code (WIPO Standard ST.3). ⁴ For Japanese patent documents, the indication of the year of the reign of the Emperor must precede the serial number of the patent document. ⁵ Kind of document by the appropriate symbols as indicated on the document under WIPO Standard ST.16 if possible. ⁶ Applicant is to place a check mark here if English language Translation is attached.

This collection of information is required by 37 CFR 1.97 and 1.98. The information is required to obtain or retain a benefit by the public which is filed and by the USPTO to process an application. Confidentiality of this information is not guaranteed. This information includes, but is not limited to, the name and address of the applicant, the name and address of the attorney, and the name and address of the inventor. All references considered except where lined through. /K.K./

Confidentiality of this information is not guaranteed. This information includes, but is not limited to, the name and address of the applicant, the name and address of the attorney, and the name and address of the inventor. All references considered except where lined through. /K.K./

form to the USPTO. Time will vary depending upon the individual case. Any comments on the amount of time you require to complete this form and/or suggestions for reducing this burden, should be sent to the Chief Information Officer, U.S. Patent and Trademark Office, P.O. Box 1450, Alexandria, VA 22313-1450. DO NOT SEND FEES OR COMPLETED FORMS TO THIS ADDRESS. SEND TO: Commissioner for Patents, P.O. Box 1450, Alexandria, VA 22313-1450.

Receipt date: 11/18/2013

14054004 (CAU): 2872

Approved for use through 07/31/2009. OMB 0367-0133
U.S. Patent and Trademark Office; U.S. DEPARTMENT OF COMMERCE

Under the Paperwork Reduction Act of 1995, no persons are required to respond to a collection of information unless it contains a valid OMB control number.

Substitute for form 1449/PTO INFORMATION DISCLOSURE STATEMENT BY APPLICANT <i>(Use as many sheets as necessary)</i>				Complete if Known		
				Application Number	14/054,004	
Sheet		13	of	13	Attorney Docket Number	DON09 P-2194
				Examiner Name	Alessandro V. Amari	
				First Named Inventor	Niall R. Lynam	
				Filing Date	October 15, 2013	
				Art Unit	2853	

FOREIGN PATENT DOCUMENTS							
Examiner initials*	Cite No. ¹	Foreign Patent Document		Publication Date MM-DD-YYYY	Name of Patentee or Applicant of Cited Document	Pages, Columns, Lines, Where Relevant Passages Or Relevant Figures Appear	T ⁶
		Country Code ²	Number ⁴ -Kind Code ⁵ <i>(if known)</i>				

		DE	2409748	1975-09-04	Leitz		
		DE	2550095	1976-05-20	Schiff et al.		
		DE	2647592	1978-04-27	Uta		
		DE	2915521	1980-10-30	Docie		
		DE	3302735	1984-08-02	Schulze		X
		DE	3329998	1985-03-07	Horn		X
		DE	3620228	1987-12-17	Thomen		X
		DE	4026578	1992-04-30	Kramer		X
		EP	0210757	1987-02-04	Von Seidel		X
		EP	0310261	1989-04-05	Britax Wingard Limited		X
		EP	0551802	1992-01-15	Jonsson		X
		EP	0791503	1997-08-27	Gentex Corporation		X
		EP	0917987	1999-05-26	Magneti Marelli France		X
		EP	0356099	1990-02-28	Yamada et al.		X
		EP	0728618	08-28-1996	Gentex Corporation		X
		EP	0729864	09-04-1996	Gentex Corporation		X
		FR	2628042	1988-03-01	Racel		X
		GB	1279158	1972-06-28	Hacker		X
		GB	2048189	1980-12-10	Mirrocraft Inc.		X
		GB	2092534	1982-08-18	Hagiri		X
		JP	0051637	1980-04-15	Katsumata Giken KK		X
		JP	55076721	1980-10-06	Nikken Kogyo KK		X
		JP	1186443	1989-07-25	Kitsumoto Norihiko		X
		JP	1208245	1989-08-22	Moriwake		X
		JP	362075619	1987-04-07	Tomita		X
		JP	62105103	1987-05-15	Miyake Shinya		X
		KR	2002092059	2002-12-11	Jung		X
		NL	7908257	1981-06-01	Bartholomeus		
		TW	424057	2001-03-01	Lin		X
		WO	2001081956	11-01-2001	Platzer, Jr.		X
		WO	2004026633	04-01-2004	Donnelly Corporation		X
		WO	2004047421	06-03-2004	Donnelly Corporation		X
		WO	2004103772	12-02-2004	Donnelly Corporation		X
		WO	2006124682	11-23-2006	Donnelly Corporation		X
		WO	2007005942	01-11-2007	Donnelly Corporation		X
		WO	2008051910	05-02-2008	Donnelly Corporation		X

Examiner Signature	/Kimberly Kakalec/	Date Considered	12/05/2013
--------------------	--------------------	-----------------	------------

*EXAMINER: Initial if reference considered, whether or not citation is in conformance with MPEP 609. Draw line through citation if not in conformance and not considered. Include copy of this form with next communication to applicant. ¹ Applicant's unique citation designation number (optional). ² See Kinds Codes of USPTO Patent Documents at www.uspto.gov or MPEP 901.04. ³ Enter Office that issued the document, by the two-letter code (WIPO Standard ST.3). ⁴ For Japanese patent documents, the indication of the year of the reign of the Emperor must precede the serial number of the patent document. ⁵ Kind of document by the appropriate symbols as indicated on the document under WIPO Standard ST.16 if possible. ⁶ Applicant is to place a check mark here if English language Translation is attached.

This collection of information is required by 37 CFR 1.97 and 1.98. The information is required to obtain certain benefits by the public which is filed by the USPTO to process an application. Confidentiality is not guaranteed. All references considered except where indicated through. /K.K./

Confidentiality is not guaranteed. All references considered except where indicated through. /K.K./

Commissioner for Patents, P.O. Box 1450, Alexandria, VA 22313-1450. DO NOT SEND FEES OR COMPLETED FORMS TO THIS ADDRESS. SEND TO:

Search Notes 	Application/Control No. 14054004	Applicant(s)/Patent Under Reexamination LYNAM, NIALL R.
	Examiner KIMBERLY N KAKALEC	Art Unit 2872

CPC- SEARCHED		
Symbol	Date	Examiner

CPC COMBINATION SETS - SEARCHED		
Symbol	Date	Examiner

US CLASSIFICATION SEARCHED			
Class	Subclass	Date	Examiner
359	838, 850, 864, 868-869, 871-878, 881-884	12/13	KNK
248	466-498	12/13	KNK

SEARCH NOTES		
Search Notes	Date	Examiner
Inventor name search.	12/13	KNK
Reviewed references cited in IDS.	12/13	KNK
EAST search (see attached search history).	12/13	KNK
Consulted with Jennifer Doak.	12/13	KNK

INTERFERENCE SEARCH			
US Class/ CPC Symbol	US Subclass / CPC Group	Date	Examiner

/K.N.K./ Examiner.Art Unit 2872	
------------------------------------	--



UNITED STATES PATENT AND TRADEMARK OFFICE

UNITED STATES DEPARTMENT OF COMMERCE
United States Patent and Trademark Office
Address: COMMISSIONER FOR PATENTS
P.O. Box 1450
Alexandria, Virginia 22313-1450
www.uspto.gov

APPLICATION NUMBER	FILING OR 371(C) DATE	FIRST NAMED APPLICANT	ATTY. DOCKET NO./TITLE
14/054,004	10/15/2013	Niall R. Lynam	DON09 P-2194

CONFIRMATION NO. 4390

15671
Gardner, Linn, Burkhart & Flory, LLP
2851 Charlevoix Dr., SE, Suite 207
Grand Rapids, MI 49546

PUBLICATION NOTICE



Title:EXTENDED FIELD OF VIEW EXTERIOR MIRROR ELEMENT FOR VEHICLE

Publication No.US-2014-0043706-A1

Publication Date:02/13/2014

NOTICE OF PUBLICATION OF APPLICATION

The above-identified application will be electronically published as a patent application publication pursuant to 37 CFR 1.211, et seq. The patent application publication number and publication date are set forth above.

The publication may be accessed through the USPTO's publically available Searchable Databases via the Internet at www.uspto.gov. The direct link to access the publication is currently <http://www.uspto.gov/patft/>.

The publication process established by the Office does not provide for mailing a copy of the publication to applicant. A copy of the publication may be obtained from the Office upon payment of the appropriate fee set forth in 37 CFR 1.19(a)(1). Orders for copies of patent application publications are handled by the USPTO's Office of Public Records. The Office of Public Records can be reached by telephone at (703) 308-9726 or (800) 972-6382, by facsimile at (703) 305-8759, by mail addressed to the United States Patent and Trademark Office, Office of Public Records, Alexandria, VA 22313-1450 or via the Internet.

In addition, information on the status of the application, including the mailing date of Office actions and the dates of receipt of correspondence filed in the Office, may also be accessed via the Internet through the Patent Electronic Business Center at www.uspto.gov using the public side of the Patent Application Information and Retrieval (PAIR) system. The direct link to access this status information is currently <http://pair.uspto.gov/>. Prior to publication, such status information is confidential and may only be obtained by applicant using the private side of PAIR.

Further assistance in electronically accessing the publication, or about PAIR, is available by calling the Patent Electronic Business Center at 1-866-217-9197.

Office of Data Management, Application Assistance Unit (571) 272-4000, or (571) 272-4200, or 1-888-786-0101

IN THE UNITED STATES PATENT AND TRADEMARK OFFICE

Group Art Unit : 2872
Examiner : Kimberly N. Kakalec
Inventor : Niall R. Lynam
Serial No. : 14/054,004
Filed : October 15, 2013
For : EXTENDED FIELD OF VIEW EXTERIOR MIRROR ELEMENT
FOR VEHICLE

Mail Stop Amendment
Commissioner for Patents
P.O. Box 1450
Alexandria, VA 22313-1450

Dear Sir:

REQUEST FOR RECONSIDERATION

Responsive to the Office Action mailed December 17, 2013, Applicant submits the following:

Remarks begin on page 2 of this paper.

Inventor : Niall R. Lynam
Serial No. : 14/054,004
Page : 2

Remarks:

The amendments and remarks presented herein are believed to be fully responsive to the Office Action dated December 17, 2013. Claims 1-20 are pending in the application.

Priority Objection:

The Office Action, at page 2, alleges that the present claims only have priority back to the filing date of the parent patent application Serial No. 12/851,045, filed August 5, 2010. Applicant respectfully traverses. The presently claimed invention is fully supported by the specification and drawings of the entire continuation chain of applications from which the present application claims priority.

The present application is a continuation of U.S. patent application Serial No. 13/776,247, filed February 25, 2013, now U.S. patent No. 8,562,157, which is a continuation of U.S. patent application Serial No. 13/776,091, filed February 25, 2013, now U.S. Pat. No. 8,591,047, which is a continuation of U.S. patent application Serial No. 13/590,854, filed August 21, 2012, now U.S. Patent No. 8,550,642, which is a divisional application of U.S. patent application Serial No. 13/336,018, filed December 23, 2011, now U.S. Patent No. 8,267,534, which is a continuation of U.S. patent application Serial No. 12/911,274, filed October 25, 2010, now U.S. Patent No. 8,128,243, which is a continuation of U.S. patent application Serial No. 12/851,045, filed August 5, 2010, now U.S. Patent No. 7,934,843, which is a continuation of U.S. patent application Serial No. 12/197,666, filed August 25, 2008, now U.S. Patent No. 7,842,154, which is a division of U.S. patent application Serial No. 10/709,434, filed May 5, 2004, now U.S. Patent No. 7,420,756, which claims the benefit of U.S. provisional application, Serial No. 60/471,872, filed May 20, 2003.

In U.S. provisional application Serial No. 60/471,872, at the top of page 5 of the application, the application states:

Inventor : Niall R. Lynam
Serial No. : 14/054,004
Page : 3

Reflective element 12 may comprise an aspheric or multi-radius or wide angle single element reflective element substrate. The reflective element 12 may provide a field of view similar to the plano-auxiliary reflective element assembly disclosed in U.S. Pat. No. 6,522,451, and in U.S. pat. application, Ser. No. 09/745,172, filed Dec. 20, 2000 for EXTERIOR MIRROR PLANO-AUXILIARY REFLECTIVE ELEMENT ASSEMBLY (Attorney Docket DON01 P-842), which are hereby incorporated herein by reference.

U.S. patent application Serial No. 09/745,172 (which published June 13, 2002 as US Publication No. US 2002/0072026 ("Lynam") and issued as U.S. Patent No. 6,717,712), in combination with the specification and drawings as filed in the '872 provisional application, fully supports the claim limitations that are set forth in the Office Action as allegedly unsupported in U.S. patent application Serial No. 12/197,666 and the parent cases from which it claims priority. Thus, because the Lynam '172 patent application was incorporated by reference in the '872 provisional application, the present claims are fully supported in the '872 provisional application filed May 20, 2003.

The Office Action alleges that the first application that provides adequate support and enablement for the claim features is application Serial No. 12/851,045. When the '045 patent application was filed, the Request for Continuation filed with the application stated "[t]he copy of the application includes Figures 9-22 and discussion thereof, which are from U.S. Patent No. 6,717,712, which is incorporated by reference in the present application and its priority applications." Thus, the paragraphs and figures physically added to the '045 application were not new matter, since they were already incorporated into the '045 application and its priority filings back to the '872 provisional application.

Thus, Applicant submits that the presently claimed invention of the present application is entitled to its priority claim back to the May 20, 2003 filing date of the '872 provisional application. Reconsideration and withdrawal of the priority claim objection is respectfully requested.

Inventor : Niall R. Lynam
Serial No. : 14/054,004
Page : 4

Claim Rejections:

Claims 1-20 were rejected under 35 U.S.C. §103(a) as being unpatentable over Lynam et al., U.S. Patent Publication No. 2002/0072026 ("Lynam '026"). Applicant respectfully traverses the rejections under 35 U.S.C. §103 for the reasons set forth below.

As set forth above, the present application is a continuation of U.S. patent application Serial No. 13/776,247, filed February 25, 2013, now U.S. patent No. 8,562,157, which is a continuation of U.S. patent application Serial No. 13/776,091, filed February 25, 2013, now U.S. Pat. No. 8,591,047, which is a continuation of U.S. patent application Serial No. 13/590,854, filed August 21, 2012, now U.S. Patent No. 8,550,642, which is a divisional application of U.S. patent application Serial No. 13/336,018, filed December 23, 2011, now U.S. Patent No. 8,267,534, which is a continuation of U.S. patent application Serial No. 12/911,274, filed October 25, 2010, now U.S. Patent No. 8,128,243, which is a continuation of U.S. patent application Serial No. 12/851,045, filed August 5, 2010, now U.S. Patent No. 7,934,843, which is a continuation of U.S. patent application Serial No. 12/197,666, filed August 25, 2008, now U.S. Patent No. 7,842,154, which is a division of U.S. patent application Serial No. 10/709,434, filed May 5, 2004, now U.S. Patent No. 7,420,756, which claims the benefit of U.S. provisional application, Serial No. 60/471,872, filed May 20, 2003.

Applicant submits that, because the present application has a priority date of May 20, 2003, which is less than one year after the publication date of Lynam '026 (June 13, 2002), and because (as discussed below) the inventor conceived and reduced to practice the invention claimed in at least independent claim 1 prior to the effective date of Lynam '026, Applicant respectfully submits that Lynam '026 is not prior art under 35 U.S.C. §102(a). Moreover, Lynam '026 is not prior art to the present claims under 35 U.S.C. §102(e) or §102(b), and thus, cannot be used against the present claims in a rejection under 35 U.S.C. §103(a).

Inventor : Niall R. Lynam
Serial No. : 14/054,004
Page : 5

As discussed above, the present application incorporates by reference U.S. Patent Nos. 6,522,451 and 6,717,712. See, for example, paragraph [0048] on page 7 of the present application (reproduced below).

[0048] Reflective element 12 may comprise an aspheric or multi-radius or wide angle single element reflective element substrate. The reflective element 12 may provide a field of view similar to the plano-auxiliary reflective element assembly disclosed in U.S. Pat. Nos. 6,522,451 and 6,717,712, which are hereby incorporated herein by reference.

With respect to the priority provisional application Serial No. 60/471,872, this application (as discussed above) similarly incorporates by reference U.S. Patent No. 6,522,451 and U.S. patent application Serial No. 09/745,172, filed December 20, 2000. U.S. patent application Serial No. 09/745,172 issued as U.S. Patent No. 6,717,712. Thus, the present application and each of the priority applications incorporate by reference the same disclosures.

With respect to the rejection in view of Lynam '026, and in accordance with 37 CFR 1.131, Applicant submits herewith a Declaration which declares that the invention claimed in at least independent claim 1 was invented by the inventor prior to the publication date of Lynam '026, namely, June 13, 2002. The specification and drawings (Exhibit A) of U.S. patent application Serial No. 09/478,315, which was filed on January 6, 2000 by Niall R. Lynam (the sole named inventor of the present application), along with U.S. Patent No. 6,522,451 (Exhibit B), which issued to Lynam from U.S. patent application Serial No. 09/478,315, and the specification and drawings (Exhibit C) of U.S. patent application Serial No. 09/745,172, which was filed on December 20, 2000 by Niall R. Lynam et al., along with U.S. Patent No. 6,717,712 (Exhibit D), which issued to Lynam et al. from U.S. patent application Serial No. 09/745,172, are submitted with the Declaration as corroborative evidence that the present invention was reduced to practice prior to the Lynam '026 publication date of June 13, 2002 (and at or prior to the December 20, 2000 filing date of the application that published as Lynam '026). The

Inventor : Niall R. Lynam
Serial No. : 14/054,004
Page : 6

Declaration is signed by the named inventor (Niall R. Lynam) for the present application. The attached specification and drawings of Exhibits A-D clearly corroborate that the invention claimed in at least independent claim 1 was reduced to practice well prior to June 13, 2002, the publication date of Lynam '026, and at or prior to December 20, 2000, the filing date of the application that published as Lynam '026.

Accordingly, the rejection of claims 1-20 under §103(a) in view of Lynam '026 is obviated, and reconsideration and withdrawal of this rejection is respectfully requested.

Claims 1-20 are pending in the application. Applicant respectfully submits that claims 1-20 are in condition for allowance and a notice to that effect is earnestly and respectfully requested.

Respectfully submitted,

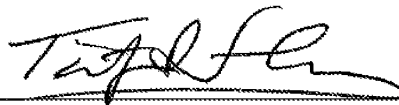

Date: March 17, 2014

Timothy A. Flory
Registration No. 42 540
Gardner, Linn, Burkhart & Flory, LLP
2851 Charlevoix Drive, S.E., Suite 207
Grand Rapids, Michigan 49546
(616) 975-5500

IN THE UNITED STATES PATENT AND TRADEMARK OFFICE

Group Art Unit : 2872
Examiner : Kimberly N. Kakalec
Inventor : Niall R. Lynam
Serial No. : 14/054,004
Filed : October 15, 2013
For : EXTENDED FIELD OF VIEW EXTERIOR MIRROR ELEMENT
FOR VEHICLE

Commissioner for Patents
P.O. Box 1450
Alexandria, VA 22313-1450

DECLARATION UNDER RULE 131(a)

Niall R. Lynam, the inventor and Applicant in the above referenced patent application, declares as follows:

1. Prior to June 13, 2002, the inventor and Applicant conceived of the claimed invention of at least the independent claims as filed in the present application. For example, and with reference to claim 1 of the present application, the inventor and Applicant conceived of an exterior sideview mirror assembly comprising:
 - a. a mirror housing;
 - b. a mirror backing plate element;
 - c. wherein said mirror backing plate element is movable within said mirror housing by an electrically-operable actuator;
 - d. a main plano mirror element fixedly disposed at a first portion of said mirror backing plate element;
 - e. said main plano mirror element having a first primary field of view rearward of a vehicle equipped with said exterior sideview mirror assembly;
 - f. an auxiliary non-plano curved mirror element fixedly disposed at a second portion of said mirror backing plate element;

Applicant : Niall R. Lynam
Serial No. : 14/054,004
Page : 2

- g. wherein said main plano mirror element and said auxiliary non-plano curved mirror element are adjacently disposed at said mirror backing plate element in a side-by-side relationship and are not superimposed with one mirror element on top of the other mirror element;
 - h. said auxiliary non-plano curved mirror element having a second auxiliary field of view rearward of the equipped vehicle;
 - i. wherein said first primary field of view of said main plano mirror element overlaps said second auxiliary field of view of said auxiliary non-plano curved mirror element;
 - j. wherein said auxiliary non-plano curved mirror element that is at said second portion of said mirror backing plate element is angled relative to said main plano mirror element that is at said first portion of said mirror backing plate element;
 - k. wherein said mirror backing plate element mounts to said actuator such that movement of said mirror backing plate element by said actuator simultaneously and similarly moves said main plano mirror element and said auxiliary non-plano curved mirror element;
 - l. wherein said mirror backing plate element comprises a polymeric molding;
 - m. wherein said main plano mirror element comprises a generally flat glass substrate having a surface coated with a metallic reflector coating;
 - n. wherein the overall rearward field of view of said main plano mirror element combined with said auxiliary non-plano curved mirror element is at least about 25 degrees relative to the side of the equipped vehicle; and
 - o. wherein the overall rearward field of view of said main plano mirror element combined with said auxiliary non-plano curved mirror element is less than about 50 degrees relative to the side of the equipped vehicle.
2. The invention of at least the independent claims of the present application was reduced to practice sometime prior to June 13, 2002, as evidenced by the attached specification and drawings (Exhibit A), which were filed with the United States Patent and Trademark Office on January 6, 2000 by Niall R. Lynam, and assigned Serial No. 09/478,315, as evidenced by the

Applicant : Niall R. Lynam
Serial No. : 14/054,004
Page : 3

attached U.S. Patent No. 6,522,451 (Exhibit B), which issued February 18, 2003 from the 09/478,315 application, and as also evidenced by the attached specification and drawings (Exhibit C), which were filed with the United States Patent and Trademark Office on December 20, 2000 by Niall R. Lynam et al. and assigned Serial No. 09/745,172, as evidenced by the attached U.S. Patent No. 6,717,712 (Exhibit D).

3. I am the sole named inventor of U.S. patent application Serial No. 14/054,004 (the present application) and I am the sole named inventor of U.S. patent application Serial No. 09/478,315 (Exhibit A), which issued as U.S. Patent No. 6,522,451 (Exhibit B), and I am a co-inventor of U.S. patent application Serial No. 09/745,172 (Exhibit C), which issued as U.S. Patent No. 6,717,712 (Exhibit D).

I hereby declare that all activities relating to the conception and reduction to practice of the above invention occurred in the United States.

I hereby declare that all statements made herein of my own knowledge are true and that all statements made on information and belief are believed to be true; and further, that the statements are made with the knowledge that willful false statements and the like so made are punishable by fine or imprisonment or both, as set forth under section 1001, title 18, of the United States Code, and that such willful false statements may jeopardize the validity of the application or any patent issuing thereon.

Inventor:

Date:



MARCH 16 2014

Niall R. Lynam

PATENT
DON01 P-793
Express Mail No. EL399135945US

IN THE UNITED STATES PATENT AND TRADEMARK OFFICE

Applicant : Niall R. Lynam
For : EXTERIOR MIRROR PLANO-AUXILIARY
REFLECTIVE ELEMENT ASSEMBLY

Box Patent Application
Assistant Commissioner for Patents
Washington, D.C. 20231

Dear Sir:

CERTIFICATE OF EXPRESS MAIL

I certify that the attached return postcard, Transmittal Letter (in duplicate), Form PTO-1619 Recordation Form Cover Sheet, Assignment, a check in the amount of \$40.00 for the recordal fee, 23 pages of Specification, 12 pages of claims (83 claims), 1 page of Abstract, 7 sheets of drawings (in duplicate), Declaration and Power of Attorney, and a check in the amount of \$1,824.00 for the filing fee are being deposited with the United States Postal Service as Express Mail in an envelope having Express Mail Label Number EL

US addressed to:

Box Patent Application
Assistant Commissioner for Patents
Washington, D.C. 20231

on January 6, 2000.

Lynette M. S. Clark
Lynette M. S. Clark
Van Dyke, Gardner, Linn & Burkhart, LLP
P.O. Box 888695
Grand Rapids, MI 49588-8695
(616) 975-5500

CSC:lmisc
Enclosures

EXHIBIT A

PATENT
DON01 P-793
Express Mail No. EL399135945US

IN THE UNITED STATES PATENT AND TRADEMARK OFFICE

Applicant : Niall R. Lynam
For : EXTERIOR MIRROR PLANO-AUXILIARY
REFLECTIVE ELEMENT ASSEMBLY

BOX PATENT APPLICATION
Assistant Commissioner for Patents
Washington, D.C. 20231

Dear Sir:

Enclosed herewith is the above identified patent application comprising the following parts:

- 1) Postcard
- 2) Assignment, Form PTO-1619 Recordation Form Cover Sheet, and Assignment Recording Fee of \$40.00
- 3) 23 Pages of Specification
- 4) 12 Pages of Claims (83 claims)
- 5) 1 Page of Abstract
- 6) 7 Sheets of Drawings (in duplicate)
- 7) Declaration and Power of Attorney

Filing Fee:

Basic Fee \$690.00	\$690.00
Additional Fees	
Each independent claim in excess of three, times \$78.00	\$
Number of claims in excess of twenty, times \$18.00	\$1,134.00
Filing multiple dependent claims per application \$260.00	\$
Total Filing Fee	<u>\$1,824.00</u>

Checks in the amount of \$1,824.00 and \$40.00 are enclosed to cover the fees noted above.

The Commissioner is hereby authorized to charge payment of the following fees associated with this communication, and during the pendency of this application, or to credit any overpayment, to Deposit Account No. 22-0190. A duplicate copy of this sheet is enclosed.

- 1) Any additional filing fees required under 37 CFR 1.16 for which full payment has not been tendered.
- 2) Any patent application processing fees under 37 CFR 1.17 for which full payment has not been tendered.

Respectfully submitted,

NIALL R. LYNAM

By: Van Dyke, Gardner, Linn & Burkhart, LLP

Date January 6, 2000

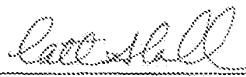
Catherine S. Collins
Registration No. 37 599
P.O. Box 888695
2851 Charlevoix Drive, S.E.
Grand Rapids, MI 49588-8695
(616) 975-5500

CSC:lmsc

**RECORDATION FORM COVER SHEET
PATENTS ONLY**

TO: The Commissioner of Patents and Trademarks: Please record the attached original document(s) or copy(ies).

Submission Type

New
 Resubmission (Non-Recordation)
Document ID#
 Correction of PTO Error
Reel # Frame #
 Corrective Document
Reel # Frame #

Conveyance Type

Assignment Security Agreement
 License Change of Name
 Merger Other
U.S. Government
(For Use ONLY by U.S. Government Agencies)
 Departmental File Secret File

Conveying Party(ies)

Mark if additional names of conveying parties attached
Execution Date
Month Day Year
01/06/2000

Name (line 1) LYNAM, Niall R.

Name (line 2)

Second Party

Name (line 1)

Name (line 2)

Execution Date
Month Day Year

Receiving Party

Mark if additional names of receiving parties attached

Name (line 1) Donnelly Corporation

Name (line 2)

Address (line 1) 414 East Fortieth Street

Address (line 2)

Address (line 3) Holland Michigan 49423
City State/Country Zip Code

If document to be recorded is an assignment and the receiving party is not domiciled in the United States, an appointment of a domestic representative is attached. (Designation must be a separate document from Assignment.)

Domestic Representative Name and Address

Enter for the first Receiving Party only.

Name

Address (line 1)

Address (line 2)

Address (line 3)

Address (line 4)

FOR OFFICE USE ONLY

Public burden reporting for this collection of information is estimated to average approximately 30 minutes per Cover Sheet to be recorded, including time for reviewing the document and gathering the data needed to complete the Cover Sheet. Send comments regarding this burden estimate to the U.S. Patent and Trademark Office, Chief Information Officer, Washington, D.C. 20231 and to the Office of Information and Regulatory Affairs, Office of Management and Budget, Paperwork Reduction Project (0651-0027), Washington, D.C. 20503. See OMB Information Collection Budget Package 0651-0027, Patent and Trademark Assignment Practice. DO NOT SEND REQUESTS TO RECORD ASSIGNMENT DOCUMENTS TO THIS ADDRESS.

Mail documents to be recorded with required cover sheet(s) information to:
Commissioner of Patents and Trademarks, Box Assignments, Washington, D.C. 20231

Correspondent Name and Address Area Code and Telephone Number (616) 975-5500

Name Catherine S. Collins

Address (line 1) Van Dyke, Gardner, Linn & Burkhart, LLP

Address (line 2) 2851 Charlevoix Drive, S.E., Suite 207

Address (line 3) P.O. Box 888695

Address (line 4) Grand Rapids, Michigan 49588-8695

Pages Enter the total number of pages of the attached conveyance document including any attachments. # 1

Application Number(s) or Patent Number(s) Mark if additional numbers attached

Enter either the Patent Application Number or the Patent Number (DO NOT ENTER BOTH numbers for the same property).

Patent Application Number(s) Patent Number(s)

If this document is being filed together with a new Patent Application, enter the date the patent application was signed by the first named executing inventor. Month Day Year 01/06/2000

Patent Cooperation Treaty (PCT) Enter PCT application number only if a U.S. Application Number has not been assigned. PCT PCT PCT

Number of Properties Enter the total number of properties involved. # 1

Fee Amount Fee Amount for Properties Listed (37 CFR 3.41): \$ 40.00 Method of Payment: Enclosed [X] Deposit Account [] Deposit Account Number: # 22-0190 Authorization to charge additional fees: Yes [X] No []

Statement and Signature To the best of my knowledge and belief, the foregoing information is true and correct and any attached copy is a true copy of the original document. Charges to deposit account are authorized, as indicated herein. Catherine S. Collins 37 599 Signature Date January 6, 2000

Express Mail No. EL399135945US
DON01 P-793

ASSIGNMENT

WHEREAS, Niall R. Lynam residing at 248 Foxdown, Holland, Michigan 49424, (hereinafter referred to as Assignor), have invented certain new and useful improvements in EXTERIOR MIRROR PLANO-AUXILIARY REFLECTIVE ELEMENT ASSEMBLY for which an application for United States Letters Patent was executed on even date herewith.

WHEREAS, Donnelly Corporation, a corporation of the State of Michigan, having a place of business at 414 East Fortieth Street, Holland, Michigan 49423 (hereinafter referred to as Assignee), is desirous of acquiring the entire right, title and interest in and to said invention and in and to any Letters Patent that may be granted therefor in the United States and in any and all foreign countries.

NOW, THEREFORE, in consideration of the sum of one dollar (\$1.00), the receipt of which is hereby acknowledged, and for other good and valuable considerations, Assignor hereby sells, assigns and transfers unto said Assignee the full and exclusive right, title and interest to the said invention in the United States and in all foreign countries and the entire right, title and interest in and to any and all Letters Patent which may be granted therefor in the United States and in any and all foreign countries and in and to any and all divisions, reissues, continuations, continuation-in-part, and extensions thereof including the full right to claim for any such applications the benefits of the International Convention.

Assignor hereby authorizes and requests the Patent Office Officials in the United States and in any and all foreign countries to issue any and all of said Letters Patent, when granted, to said Assignee as the owner of the entire right, title and interest in and to the same, for the sole use and behoof of said Assignee, its successors and assigns.

FURTHER, Assignor agrees to communicate to said Assignee or its representatives any facts known to Assignor respecting said invention, and testify in any legal proceeding, sign all lawful papers, execute all divisional, continuation, continuation-in-part, substitution, renewal, and reissue applications, execute all necessary assignment papers to cause any and all of said Letters Patent to be issued to said Assignee, make all rightful oaths and generally do everything possible to aid said Assignee, its successors and assigns, to obtain and enforce proper protection for said invention in the United States and in any and all foreign countries.

IN TESTIMONY WHEREOF, I have hereunto set my hand on the date appearing next to my signature.

Witness:

Donetta D. Vandine

Inventor:

Niall R. Lynam
Niall R. Lynam

Date:

JAN 6 2000

EXTERIOR MIRROR PLANO-AUXILIARY REFLECTIVE ELEMENT ASSEMBLY

TECHNICAL FIELD AND BACKGROUND OF THE INVENTION

The present invention relates to exterior sideview mirror assemblies suitable for use on an automobile, and more specifically, to plano-auxiliary reflective element assemblies
5 for use in automobile exterior sideview mirror assemblies.

Automobiles are typically equipped with an interior rearview mirror assembly (adapted for providing a rearward field of view immediately rearward of the vehicle, typically principally in the road lane the vehicle is traveling in) and at least one exterior sideview mirror assembly attached to the side of the vehicle (typically adjacent a front side
10 window portion). The exterior side view mirror assembly typically comprises a reflective element adapted to provide a rearward field of view of the side lane adjacent the vehicle so as to allow the driver see whether a side approaching vehicle is present when the driver is contemplating a lane change. Conventionally, automobiles are equipped with a driver-side exterior mirror assembly and, very often, with a passenger-side exterior sideview mirror
15 assembly mounted to the side of the automobile body opposite to that of the driver-side assembly. While the combination of an interior rearview mirror with a driver-side exterior mirror (and especially in a three-mirror system comprising an interior rearview mirror with a driver-side exterior mirror and a passenger-side exterior mirror) works well in many driving situations, rear vision blind spots present a potential safety hazard while driving. A rear
20 vision blind spot is an area adjacent the side of an automobile where a view of another vehicle (overtaking on that side) is not captured in the rearward field of view of the exterior mirror reflector on that side. This presents a potential safety hazard as the driver, upon checking the view in the exterior sideview mirror and seeing no overtaking vehicle therein, may deem it safe to initiate a lane change, unaware that there is a vehicle immediately
25 adjacent in a blind-spot of the exterior mirror reflector.

Various attempts have been made conventionally to minimize and/or eliminate exterior mirror blind-spots on vehicles. One approach is to make the exterior mirror reflector larger, and particularly wider with respect to the vehicle body. By increasing the width of the exterior mirror reflector, it has a wider field of view rearwards, and hence the reflector blind-

spot is reduced. While use of a wide exterior mirror reflector is an option for trucks, buses and commercial vehicles, increasing the width of the reflector used in an exterior sideview mirror assembly mounted on automobiles (such as sedans, station wagons, sports cars, convertibles, minivans, sports utility vehicles, pick-up trucks and similar passenger carrying automobiles) is often not an option. In such domestic automobiles, increasing the width of the exterior mirror reflector increases the size of the exterior sideview mirror assembly with a concomitant increase in aerodynamic drag, increase in fuel consumption, increased difficulty in parking in tight parking spaces, and increased reflector vibration. Use of a non-flat, curved exterior mirror reflector is commonly used to increase rearward field of view without increasing reflector size.

While working well to increase field of view, use of a curved reflector (such as a convex, spherically-curved reflector) has disadvantages. The field of view rearward increases as the degree of curvature of the bent substrate increases (i.e., the field of view rearward increases as the radius of curvature of the bent substrate decreases). However, such wide-angle mirrors have non-unit magnification and distance perception rearward is distorted. For this reason, convex (spherically-bent) exterior mirror reflectors are required in some countries (such as the United States) to carry a safety warning "OBJECTS IN MIRROR ARE CLOSER THAN THEY APPEAR". Distance perception is particularly important for a driver-side exterior mirror. Indeed, Federal Vehicle Safety Standard No: 111 in the United States (the entire disclosure of which is hereby incorporated by reference herein) requires that the driver-side exterior mirror reflector exhibit unit magnification, and places restrictions on the radius of curvature allowed for any bent passenger-side mirror as well as requiring a safety warning be placed thereon. As an improvement over spherically bent/convex mirror reflectors, aspherical or multiradius mirror reflectors (such as are disclosed in U.S. Patents 4,449,786 and 5,724,187, the entire disclosures of which are hereby incorporated by reference herein) have been developed. Such mirrors are widely used in Europe and Asia for both driver-side exterior mirror reflectors and for passenger-side exterior mirror reflectors. The aspherical or multiradius mirror reflectors typically have a less curved (larger radius of curvature) reflective region that is inboard or closest to the driver when mounted on a vehicle and, usually separated by a demarcation line or the like, have a more curved (smaller radius of curvature) region that is outboard or farthest from the driver when mounted on a vehicle. However, such aspherical or multiradius reflectors do not have unit

magnification and so cannot be used when unit magnification is mandated (such as by FMVSS 111, referenced above).

To supplement a flat driver-side exterior mirror reflector, an auxiliary and separate bent reflector is sometimes incorporated into the driver-side exterior sideview mirror assembly. However, this is often not suitable for passenger automobiles because of the extra space required in the sideview mirror assembly to accommodate an auxiliary reflector element. Also, in most passenger automobiles, the position of the side view mirror reflector is adjustable by the driver (such as by a hand-adjust, or by a manually adjustable cable such as a Bowden cable or by an electrically operable actuator, as known in the art) in order to provide to that driver his or her desired rearward field of view, which ill-suits use of a separate, auxiliary reflector. Likewise, addition of stick-on blind-spot mirror reflectors (such as are commonly sold in automotive parts stores and the like) onto an automobile exterior sideview mirror reflector has disadvantages, including obscuring field of view of the automobile mirror reflector and adding to mirror element vibration.

There is thus a need to provide an automobile exterior sideview reflective element, and particularly a driver-side automobile exterior sideview reflective element, that overcomes the disadvantages above and that provides the driver of the automobile with a distortion-free field of view with unit magnification that is supplemented with a wide-angle view of a side lane blind spot, and there is a need that this be provided in a unitary reflective element assembly module suitable to mount onto, and be adjusted by, the mirror reflector adjustment mechanism (such as an electrically operated, motorized actuator) provided in the exterior sideview mirror assembly.

BRIEF DESCRIPTION OF THE DRAWINGS

Fig. 1 is a perspective view of an automobile equipped with exterior sideview mirror assemblies according to this present invention;

Fig. 2 is a top plan partial fragmentary view of the driver's side exterior rearview mirror assembly of Fig. 1;

Fig. 3 is an enlarged sectional view of a plano-multiradius reflective element assembly of the mirror assembly in Fig. 2;

Fig. 4 is an enlarged sectional view of a demarcation element of the plano-multiradius reflective element assembly of Fig. 3;

Fig. 5A-5H illustrate views of various locations for a plano reflective element and an auxiliary reflective element according to this present invention;

Fig. 6 is a sectional view of a second embodiment of a plano reflective element assembly according to the present invention including a demarcation element formed as a dividing wall in a backing plate element;

Fig. 6A is a cross-section taken along line XX of Fig.6;

Fig. 6B is a cross-sectional view taken along line YY of Fig.6; and

Fig. 7 is a schematic of a third embodiment of a plano-auxiliary reflective element assembly according to this present invention.

SUMMARY OF THE INVENTION

This invention provides a plano reflective element with unit magnification and an auxiliary reflector element for use in an exterior sideview mirror assembly on an automobile. More specifically, this invention provides a plano-multiradius reflective element assembly suitable for use in an exterior sideview mirror assembly mounted to the side body of an automobile. The plano-multiradius reflective element assembly of this invention is especially suitable for mounting in a driver-side exterior sideview mirror assembly that is mounted to the side of the automobile body adjacent to the seating position of the driver in the front of the interior vehicular cabin. The plano-multiradius reflective element assembly of this invention comprises a plano portion which has a rearward field of view, when mounted in an exterior sideview mirror assembly mounted to the side body of an automobile, with unit magnification. This plano portion comprises a flat substrate, typically a flat glass substrate, provided with a reflective surface. The plano-multiradius reflective element assembly of this invention also includes a multiradius portion with a rearward field of view, when mounted in an exterior sideview mirror assembly mounted to the side body of an automobile, that has non-unit magnification. The plano portion provides a distortion-free rearward field of view and serves as the principal rearward-viewing portion of the plano-multiradius reflective element. The multiradius portion provides a wide angle rearward field of view, and typically supplements the rearward field of view of the plano portion. This multiradius portion comprises a curved substrate, typically a bent glass substrate, provided with a reflective surface. The plano portion and the multiradius portion are demarcated apart by a demarcation element. The demarcation element enables the driver of a vehicle equipped with the plano-multiradius reflective element of this invention to readily delineate a rearward

view in the plano portion from a rearward view in the multiradius portion. The plano portion comprises a flat reflective element and the multiradius portion comprises a bent reflective element. The flat, plano reflective element and the curved, multiradius reflective element are individually and separately manufactured, and are adjacently attached to a single backing plate (which typically comprises a polymeric substrate, most typically a molded polymeric substrate), and with the demarcation element disposed at the joint of the plano, flat reflective element and the multiradius, bent reflective element. The backing plate is fabricated (typically by polymeric molding) to have a flat portion that corresponds to the plano, flat reflective element, and a curved surface that corresponds to the multiradius, curved reflective element. The attachment of the plano reflective element and an auxiliary reflective element to a single backing plate produces a unitary plano-auxiliary reflective element assembly module suitable for mounting in an exterior sideview mirror assembly. By adjusting the position of the backing plate within the exterior sideview mirror assembly, the rearward fields of view of both the plano reflective element and the auxiliary reflective element are simultaneously and similarly aligned.

One embodiment of the invention includes an exterior sideview mirror system suitable for use in an automobile comprising an exterior sideview mirror assembly adapted for attachment to a side of the automobile. The exterior sideview mirror assembly includes a reflective element having a rearward field of view when attached to said side of the automobile. The reflective element is attached to an actuator and is movable by the actuator in order to position the reflective element's rearward field of view in response to a control. The reflective element comprises a plano-multiradius reflective element assembly which comprises a plano reflective element having unit magnification and a separate multiradius reflective element having a multiradius curvature. The plano element and the separate multiradius element of the plano-multiradius reflective element assembly are attached to a backing plate element. The backing plate element is mounted to the actuator such that movement of the backing plate element (and hence the plano-multiradius reflective element assembly) by the actuator simultaneously and similarly moves the plano element and the multiradius element. The plano element and the multiradius element are separately and, preferably, adjacently attached to the backing plate element at a joint.

In a further embodiment, a demarcation element is disposed at this joint to form a demarcation between the plano element and the multiradius element; this demarcation

element having a portion visible to a driver of the automobile. Preferably, the demarcation element is dark colored, such as with a color selected from the group consisting of black, grey, blue and brown. Optionally, there is a space at the joint of the plano element and the multiradius element and the demarcation element is at least partially disposed in said space
5 between said plano element and said multiradius element. The demarcation element can comprise at least one of a polymer material, a tape, a plastic film, a paint, a lacquer and a caulk.

In a further embodiment, the demarcation element comprises a wall on the backing plate element; this wall being located on the backing plate element at the joint of the
10 plano element and the multiradius element, this wall separating the respective elements apart.

In preferred embodiments, the portion of the demarcation element visible to a driver of an automobile equipped with the plano-multiradius reflective element assembly of this invention has a width from about 0.5 mm to about 4 mm.

In preferred embodiments, the plano element is attached to the backing plate
15 element by at least one of an adhesive attachment and a mechanical attachment.

In preferred embodiments, the multiradius element is attached to the backing plate element at a location such that, when the exterior mirror assembly is attached to a side of an automobile, at least portion, and preferably at least a substantial portion, of the plano element is disposed closer to the side of the vehicle than any portion of the multiradius
20 element element.

In preferred embodiments, the multiradius element comprises a bent glass substrate with radii of curvature in the range of from about 4000 mm to about 50 mm, and the ratio of the width of the plano element to the width of the multiradius element is greater than
I.

In preferred embodiments, the principal axis of the rearward field of view of the auxiliary, multiradius element is different from and angled to the principal axis of the rearward field of view of the plano element when both are attached to the backing plate element of the plano-multiradius reflective element assembly and when the plano-multiradius reflective element assembly is mounted in an exterior sideview mirror assembly on an
25 automobile. The principal axis of the rearward field of view of the plano element is directed generally parallel to the longitudinal axis of an automobile equipped with the plano-multiradius reflective element assembly and the principal axis of the rearward field of view
30

of the multiradius element is directed generally at an angle downwards to the longitudinal axis of the vehicle.

In a preferred embodiment, the exterior sideview mirror assembly equipped with the plano-multiradius reflective element assembly comprises a fixedly attached exterior sideview mirror assembly. In another preferred embodiment, the exterior sideview mirror assembly equipped with the plano-multiradius reflective element assembly comprises a break-away exterior sideview mirror assembly. In another preferred embodiment, the exterior sideview mirror assembly equipped with the plano-multiradius reflective element assembly comprises a powerfold exterior sideview mirror assembly. In another preferred embodiment, the actuator of the exterior sideview mirror assembly to which the plano-multiradius reflective element assembly is mounted comprises an electrically operable actuator. In another preferred embodiment, the actuator of the exterior sideview mirror assembly to which the plano-multiradius reflective element assembly is mounted is controlled by a switch or by a memory controller. In another preferred embodiment, the plano element and/or the multiradius element of the plano-multiradius reflective element assembly comprises an electro-optic reflective element, preferably an electrochromic reflective element. In another preferred embodiment, the plano element of the plano-multiradius reflective element assembly comprises an electro-optic reflective element, preferably an electrochromic reflective element, and the multiradius element comprises a fixed reflectance mirror reflector, such as a fixed reflectance mirror reflector comprises a bent glass substrate coated with a metallic reflector coating.

In a preferred embodiment, the plano-auxiliary reflective element assembly is formed in an integral molding operation.

These and other advantages, features, and modifications will become more apparent when reviewed in conjunction with the drawings and the detailed description which follows.

DETAILED DESCRIPTION OF THE PREFERRED EMBODIMENTS

As illustrated in Fig. 1, passenger automobile 10 (which may be a sedan, a station-wagon, a sports car, a convertible, a minivan, a sports utility vehicle, a pick-up truck or a similar passenger carrying non-commercial, personal transportation automobile) includes an interior rearview mirror assembly 18 positioned within interior vehicle cabin 25. Interior vehicle cabin 25 further includes a steering wheel 16, a driver seat 20 positioned at

steering wheel 16, a front passenger seat 21 adjacent to driver seat 20 in the front portion of cabin 25, and a rear passenger seat 23 in the rear portion of cabin 25. Automobile 10 further includes a driver-side exterior sideview mirror assembly 12 and a passenger-side exterior sideview mirror assembly 14, each adapted for attachment to opposing sides of automobile body 11, most preferably adjacent to the seating position of the driver seated in driver seat 20 for driver-side assembly 12 and adjacent to the front passenger seat 21 for passenger-side assembly 14. Exterior sideview mirrors, mounted as shown in Fig. 1 close to the driver seating location, are commonly referred to as door-mounted exterior sideview mirror assemblies. Driver-side exterior sideview mirror assembly 12 includes, as illustrated in Fig. 2, a plano-multiradius exterior sideview reflective element assembly 30. Plano-multiradius reflective element assembly 30 is mounted to a reflective element positioning actuator 36. The orientation of plano-multiradius reflective element assembly 30, and hence its rearward field of view, is adjustable by actuator 36 in response to control 37. Control 37 can comprise a handset control that allows the driver manually move the orientation of plano-multiradius reflective element assembly 30 within exterior mirror housing 40 (such as by a lever control or by a cable control) and hence reposition the rearward field of view of plano-multiradius reflective element assembly 30. Alternately, when actuator 36 comprises an electrically actuated actuator that is electrically operable incorporating at least one motor, control 37 can comprise a switch (which, preferably, is operable under control of the driver seated in cabin 25) or control 37 can comprise a memory controller, as known in the automotive mirror art, that controls actuator 36 to move the position of plano-multiradius reflective element assembly 30 to a pre-set orientation that suits the rearward field of view preference of an individual driver. Actuator 36 is mounted to bracket 38 which attaches to vehicle body side 11. Plano-multiradius reflective element assembly 30 is positionable by actuator 36 within exterior mirror housing 40.

Plano-multiradius reflective element assembly 30, as shown in Fig. 3, comprises a plano element 50 and a separate multiradius element 55. Preferably, plano element 50 is adjacent to multiradius element at a joint. At their joint, plano element 50 and separate multiradius element 55 can touch leaving substantially no gap or space therebetween, or plano element 50 and separate multiradius element 55 can be spaced apart at their joint by a space or gap, as in Fig. 3. Plano element 50 and multiradius element 55 are both mounted to surface 59 of, and are both supported by, a single backing plate element 60.

Plano element 50 and multiradius element 55 are demarcated apart by demarcation element 65. Surface 61 of backing plate element 60 is preferably adapted to attach, such as by attachment member 64, to actuator 36 when plano-multiradius reflective element assembly 30 is mounted in driver-side exterior sideview mirror assembly 12 (and/or in passenger-side exterior side view mirror assembly 14) such that plano element 50 and multiradius element 55 are adjusted and positioned in tandem and simultaneously when the driver (or alternatively, when a mirror memory system, as is conventional in the rearview mirror arts) activates actuator 36 to reposition the rearward field of view of plano-multiradius reflective element assembly 30. Thus, since elements 50, 55 are part of plano-multiradius reflective element assembly 30, movement of plano-multiradius reflective element assembly 30 by actuator 36 simultaneously and similarly moves plano element 50 and multiradius element 55.

Plano element 50 preferably comprises a flat reflector-coated glass substrate having unit magnification, and comprises a reflective surface through which the angular height and width of the image of an object is equal to the angular height and width of the object when viewed at the same distance (except for flaws that do not exceed normal manufacturing tolerances). Plano element 50 may comprise a conventional fixed reflectance mirror reflector or it may comprise a variable reflectance mirror reflector whose reflectivity is electrically adjustable. For example, plano element 50 may comprise a flat glass substrate coated with a metallic reflector coating such as a chromium coating, a titanium coating, a rhodium coating, a metal alloy coating, a nickel-alloy coating, a silver coating, an aluminum coating (or any alloy or combination of these metal reflectors). The metal reflector coating of plano element 50 may be a first surface coating (such as on surface 66) or a second surface coating (such as on surface 67), as such terms are known in the mirror art. The reflector coating on plano element 50 may also comprise a dielectric coating, or a multilayer of dielectric coatings, or a combination of a metal layer and a dielectric layer to form automotive mirror reflectors as known in the automotive mirror art. If a variable reflectance reflector element, plano element 50 preferably comprises an electro-optic reflector element and, most preferably, an electrochromic reflector element.

When mounted into exterior side view mirror assembly 12 and/or 14, plano-multiradius reflective element assembly 30 is preferably orientated so that at least a portion of (more preferably a substantial portion of) the reflector surface of plano element 50 is

positioned closer to the vehicle body (and hence to the driver) than any portion of the reflector surface of multiradius element 55. Thus, and referring to Figure 3, side A of plano element 50 of plano-multiradius reflective element assembly 30 is positioned closer to the driver than side D of multiradius element 55 when plano-multiradius reflective element assembly 30 is mounted on an automobile. Also, when mounted into exterior side view mirror assembly 12 and/or 14, surfaces 66, 68 of plano-multiradius reflective element assembly 30 face rearwardly in terms of the direction of vehicle travel.

Multiradius element 55 of plano-multiradius reflective element assembly 30 preferably comprises a curved/bent mirrored glass substrate. The degree of curvature preferably increases (and hence the local radius of curvature decreases) across the surface of multiradius element 55 with the least curvature (largest radius of curvature) occurring at the side of multiradius element 55 (side C in Fig. 3) positioned adjacent its joint to plano element 50 when both are mounted on backing plate element 60. Thus, and referring to Figure 3, the local radius of curvature at side C of multiradius element 55, when mounted on backing plate element 60, is larger than at side D. Also, the local radius of curvature preferably progressively decreases across multiradius element 55 from side C to side D. Preferably, the local radius of curvature at side C of multiradius element 55 is at least about 1000 mm; more preferably is at least about 2000 mm and most preferably is at least about 3000 mm whereas the local radius of curvature at side D of multiradius element 55 is, preferably, less than about 750 mm, more preferably less than about 350 mm; most preferably less than about 150 mm. Preferably, multiradius element 55 comprises a bent glass substrate with radii of curvature in the range of from about 4000 mm to about 50 mm. The multiradius prescription for the multiradius element to be used in a particular exterior mirror assembly can vary according to the specific field of view needs on a specific automobile model.

The total field of view rearwardly of the automobile of the plano-auxiliary reflective element assembly (which is a combination of the field of view of the plano reflective element and of the auxiliary reflective element) preferably generally subtends an angle of at least about 20 degrees (and more preferably, generally subtends an angle of at least about 25 degrees and most preferably, generally subtends an angle of at least about 30 degrees) with respect to the side of an automobile to which is attached an exterior sideview mirror assembly equipped with the plano-auxiliary reflective element assembly.

Multiradius element 55 may comprise a conventional fixed reflectance mirror reflector or it may comprise a variable reflectance mirror reflector whose reflectivity is electrically adjustable. For example, multiradius element 55 may comprise a flat glass substrate coated with a metallic reflector coating such as a chromium coating, a titanium coating, a rhodium coating, a metal alloy coating, a nickel-alloy coating, a silver coating, an aluminum coating (or any alloy or combination of these metal reflectors). The metal reflector coating of multiradius element 55 may be a first surface coating (such as on surface 68) or a second surface coating (such as on surface 69), as such terms are known in the mirror art. The reflector coating on multiradius element 55 may also comprise a dielectric coating, or a multilayer of dielectric coatings, or a combination of a metal layer and a dielectric layer to form automotive mirror reflectors as known in the automotive mirror art. If a variable reflectance reflector element, multiradius element 55 preferably comprises an electro-optic reflector element and, most preferably, an electrochromic reflector element.

Also, it is preferable that the thickness of plano element 50 and multiradius element 55 be substantially the same in dimension so that their respective outer surfaces, 66 and 68, are substantially coplanar so that a driver can readily view images in either or both elements. The thickness dimension of elements 50,55 is determined by the thickness of the substrate (or in the case of laminate-type electrochromic reflective elements, the thickness of the two substrates between which the electrochromic medium is disposed). For example, plano element 50 and/or multiradius element 55 can comprise a reflector coated glass substrate or panel of thickness preferably equal to or less than about 2.3 mm, more preferably equal to or less than about 1.6 mm, most preferably equal to or less than about 1.1 mm. Use of a thinner substrate is beneficial in terms of improving the overall stability/vibration performance of the image seen in plano-multiradius reflective element assembly 30 when mounted to an automobile.

The reflector area of plano element 50 is preferably larger than that of multiradius element 55. Preferably, the width dimension of plano element 50 is larger than the width dimension of multiradius element 55 (both width dimensions measured at their respective widest dimension and with the width of the respective element being gauged with the respective element oriented as it would be orientated when mounted on the automobile). Thus, and referring to Figure 3, the distance from side A to side B of plano element 50 is larger than the distance from side C to side D of multiradius element 55. Thus, the ratio of

the width of plano element 50 to the width of multiradius element 55 is preferably greater than 1; more preferably greater than 1.5; most preferably greater than 2.5 in order to provide a large, unit magnification plano element 50 as the principal rear viewing portion of plano-multiradius reflective element assembly 30 and providing multiradius element 55 as a smaller, auxiliary, separate, wide-angle viewing portion of plano-multiradius reflective element assembly 30. For plano-multiradius reflective element assemblies to be mounted to the exterior sideview assemblies of passenger automobiles used non-commercially and for non-towing purpose, the width of plano element 50 (at its widest dimension) is preferably in the range of from about 50 mm to about 225 mm; more preferably in the range of from about 75 mm to about 175 mm; most preferably in the range of from about 100 mm to about 150 mm.

Backing plate element 60 is preferably a rigid polymeric substrate capable of supporting plano element 50 and multiradius element 55. Backing plate element 60 comprises a flat portion (generally between E and F as shown in Fig. 3) that corresponds to and is aligned with plano element 50. Backing plate element 60 also comprises a curved portion (generally between G and H as shown in Fig. 3) that corresponds to and is aligned with multiradius element 55. Preferably, curved portion G-H of multiradius element 55 is fabricated with a multiradius prescription that is substantially the same as the multiradius prescription of multiradius element 55. Backing plate element 60 is formed as a single element to which elements 50 and 55 are separately attached. Preferably, backing plate element 60 is formed by injection molding of a thermoplastic or a thermosetting polymer resin. Materials suitable to use for backing plate element 60 include unfilled or filled polymeric materials such as glass and/or mineral filled nylon or glass and/or mineral filled polypropylene, ABS, polyurethane and similar polymeric materials. For example, backing plate element 60 can be formed of ABS in an injection molding operation. Plano element 50 can be cut from a stock lite of flat chromium mirror-coated 1.6 mm thick glass. Multiradius element 55 can be cut from a stock lite of multiradiusly-bent chromium mirror-coated 1.6 mm thick glass. Plano element 50 and multiradius element 55 can then be attached (such as by an adhesive attachment such as an adhesive pad or by mechanical attachment such by clips, fasteners or the like) to the already molded backing plate element 60. Alternatively, plano element 50 and multiradius element 55 can each be individually loaded into an injection molding tool. Once loaded, a polymeric resin (or the monomers to form a

polymeric resin) can be injected into the mold in order to integrally form backing plate element 60 with elements 50, 55 integrally molded thereto. Integral molding of the backing plate element to plano element 50 and multiradius element 55 (along with any other elements such as the demarcation element 65) in a single integral molding operation, is a preferred
5 fabrication process for plano-multiradius reflective element assembly 30.

Plano-multiradius reflective element assembly 30 further preferably includes demarcation element 65 that functions to delineate and demarcate the plano region of the assembly from the wide-angle, multiradius region and also preferably functions to prevent ingress of debris, dirt, water and similar contaminants (such as road splash, car wash spray,
10 rain, snow, ice, leaves, bugs and similar items that plano-multiradius reflective element assembly 30 would be subject to when mounted and used on an automobile) into any gap between plano element 50 and multiradius element 55 when both are attached to backing plate element 60. Optionally, at least a portion of demarcation element 65 can be disposed in any gap between plano element 50 and multiradius element 55 at their joint on backing plate
15 element 60. Preferably, demarcation element 65 is formed of a polymeric material that is dark colored (such as black or dark blue or dark brown or dark grey or a similar dark color) such as a dark colored polypropylene resin or a dark colored nylon resin or a dark colored polyurethane resin or a dark colored polyvinyl chloride resin or a dark colored silicone material. Most preferably demarcation element 65 is formed of an at least partially
20 elastomeric material (such as silicone, or EPDM, or plasticized PVC or the like) in order to provide a degree of vibration dampening for elements 50, 55. As shown in Fig. 4, demarcation element 65 optionally includes a crown portion 70 that includes wing portions 73, 73' and a stem portion 71. Stem portion 71 preferably has a cross-sectional width CCC of less than about 4 mm, more preferably less than about 3 mm and, most preferably less than
25 about 2 mm. Crown portion 70 preferably is dimensioned to not protrude substantially beyond surfaces 66, 68 of elements 50, 55 when demarcation element 65 is installed between elements 50 and 55. Also, wings 73, 73' are preferably dimensioned to protrude (most preferably slightly) onto surfaces 66, 68 of elements 50, 55 when demarcation element 65 is installed between elements 50 and 55 in order to provide a weather barrier seal and/or to at
30 least partially accommodate any dimensional tolerances of elements 50, 55 that could lead to variation in the inter-element gap between sides C and B. While the demarcation element shown in Fig. 4 is one embodiment, other constructions are possible including a demarcation

element that has minimal or no crown portion. Likewise, a demarcation element can have little or no stem portion, especially when the joint between plano element 50 and multiradius element 55 includes no gap to receive a stem. Also, where a gap at the plano to multiradius joint exists, any stem of the demarcation element can at least partially be disposed in such gap so as to at least partially fill the gap (or it can optionally substantially fill the gap).
5
Optionally, demarcation element 65 is fabricated by injection molding of a polymeric resin. After plano element 50 and multiradius element 55 have been attached to backing plate element 60, a separately formed demarcation element 65 can then be inserted (and secured such as by an adhesive or by a mechanical attachment such as by a fastener) into a space
10 between elements 50 and 55. Note that, optionally, side B of plano element 50 and side C of multiradius element 55 can touch (leaving substantially no gap or space therebetween). In such a situation, demarcation element 65 can comprise a dark colored strip such as of a tape or of a plastic film that covers the joint between elements 50 and 55. Alternatively, demarcation element 65 can comprise a preferably dark-colored paint, lacquer, caulk or
15 similar material that can be applied to, and that can preferably fill into, the joint between elements 50 and 55. The width of the portion of demarcation element 65 that is visible to the driver is preferably less than about 4 mm, more preferably less than about 3 mm and most preferably less than about 2 mm, but is equal to or greater than about 0.5 mm, more preferably is equal to or greater than about 0.75 mm, most preferably is equal to or greater
20 than about 1 mm in order to provide adequate demarcation of the plano region from the multiradius radius region without unduly obscuring the rearward field of view of the respective elements. Optionally, demarcation element 65 can be formed as part of backing plate element 60 such as by forming demarcation element 65 as a wall structure of the backing plate element that partitions backing plate element 60 into two regions: A first
25 region adapted to receive plano reflective element 50 and a separate and adjacent second region adapted to receive multiradius reflective element 55.

Thus, and referring to Fig. 6, a second embodiment of plano-multiradius reflective element assembly 130 may include a backing plate element 160 which comprises a plate molded from a polymer resin (such as a polyolefin such as polypropylene or such as
30 ABS or nylon) with a demarcation element 165 that is molded as a wall structure that partitions backing plate element 165 into a first region (from CC to BB) adapted to receive and accommodate plano reflective element 150 and into a second region (from BB to AA)

adapted to receive and accommodate wide-angle optic multiradius reflective element 155. Note that section AA to BB of backing plate element 160 is angled to section BB to CC. Such angling of the auxiliary reflective element relative to the plano element can be advantageous in allowing the auxiliary reflective element view a portion of the road adjacent the automobile that is in a blind spot of the plano reflective element. In this regard, it is preferable that the multiradius element be angled away from the plane of the plano element, as shown in Fig. 6 by the angling of section AA to BB to section BB to CC.

Preferably, demarcation element 65 is formed in an integral molding operation, along with formation of backing plate element 60, and attachment of elements 50, 55 thereto. For example, plano element 50 and multiradius element 55 can each be individually loaded into an injection molding tool. Once loaded, a polymeric resin (or the monomers to form a polymeric resin) can be injected into the mold in order to integrally form backing plate element 60 with elements 50, 55 integrally molded thereto and, in the same molding operation and in the same tool, also form by molding the demarcation element. Integral molding of the backing plate element to plano element 50 and multiradius element 55 along with creation in the single molding operation of demarcation element 65 (along with any other elements such as attachment member 64) in a single integral molding operation, is a preferred fabrication process for plano-multiradius reflective element assembly 30. By loading all the sub components of plano-multiradius reflective element assembly 30 into a molding tool, and then injecting polymeric resin to form the backing plate, demarcation member and any attachment member, a substantially complete or fully complete plano-multiradius reflective element assembly can be unloaded from the tool at the completion of the integral molding operation (as known in the molding art), thus enabling economy in manufacturing and accommodation of any dimensional tolerances in the sub components. Where integral molding is so used, it is preferable to use a reactive molding operation such as reactive injection molding of a urethane as such reactive injection molding operations occur at relatively modest temperatures.

Plano element 50 and/or multiradius element 55 can comprise a heater element, as known in the automotive mirror art, that is operable to deice/demist surfaces 66, 68. Such heater elements are conventional and can comprise a positive temperature coefficient heater pad, a resistive heater element and/or a conductive coating. Plano element 50 and/or multiradius element 55 can also optionally comprise a scatterproofing member, as

known in the automotive mirror art, such as an adhesive tape, to enhance safety in an accident.

Also, plano element 50 and/or multiradius element 55 can comprise a variable reflectance electro-optic element such as an electrochromic mirror reflector. Thus, both element 50 and element 55 can comprise an electrochromic mirror element or either of element 50 and element 55 can comprise an electrochromic mirror element and the other can comprise a fixed reflectance non-variable reflectance mirror element such as a metal reflector coated glass panel such as a chromium coated glass substrate. Also, if both plano element 50 and multiradius element 55 comprise an electro-optic element such as an electrochromic mirror element capable of electrically dimmable reflectivity, both elements 50, 55 can dim together and in tandem under control of a common dimming control signal (typically provided by an electro-optic automatic dimming interior mirror assembly mounted in the cabin of the automobile and equipped with photosensors to detect incident glare and ambient light). Alternately, if both plano element 50 and multiradius element 55 comprise an electro-optic element such as an electrochromic mirror element capable of electrically dimmable reflectivity, element 50 can dim independently of element 55 (such as is disclosed in U.S. Patent No. 5,550,677, the entire disclosure of which is hereby incorporated by reference herein). If either or both of elements 50, 55 comprise an electrochromic element, preferably, the electrochromic reflective element comprises a front substrate and a rear substrate with an electrochromic medium disposed between, such as a solid polymer matrix electrochromic medium such as is disclosed in U.S. patent application Serial No. 09/350,930, filed July 12, 1999, entitled "ELECTROCHROMIC POLYMERIC SOLID FILMS, MANUFACTURING ELECTROCHROMIC DEVICES USING SUCH FILMS, AND PROCESSES FOR MAKING SUCH SOLID FILMS AND DEVICES" to Desaraju V. Varaprasad et al., or such as is disclosed in U.S. Patent Nos. 5,668,663; 5,724,187; 5,910,854; and 5,239,405, the entire disclosures of which are hereby incorporated by reference herein. Most preferably, in such laminate-type electrochromic mirror reflective elements, the front substrate comprises a glass plate of thickness less than about 1.6 mm, most preferably about 1.1 mm thickness or lower, and the rear substrate comprises a glass plate of thickness equal to or greater than about 1.6mm, more preferably greater than about 1.8 mm thickness, most preferably equal to or greater than about 2.0 mm thickness. The rearmost surface of the rear substrate (the fourth surface as known in the mirror art) is reflector coated with a high reflecting metal film such

as of aluminum or silver, or an alloy of aluminum or silver. Most preferably, the front-most surface of the rear substrate (the third surface as known in the mirror art) is reflector coated with a high reflecting metal film such as of aluminum or silver, or an alloy of aluminum or silver.

5 Backing plate element 65 of plano-multiradius reflective element assembly 30 is optionally equipped on its rearmost surface with attachment member 64 to facilitate attachment to the reflector-positioning actuator of the exterior sideview mirror assembly that plano-multiradius reflective element assembly 30 is mounted to. Attachment of plano-multiradius reflective element assembly 30 to the actuator can be by mechanical attachment
10 such as by a tab, clip or fastener, or may be by adhesive attachment such as by a silicone adhesive, a urethane adhesive or a similar adhesive material such as a tape coated on both surfaces with a pressure sensitive adhesive to form a "double-sticky" tape. The exterior sideview mirror assembly, on whose mirror reflector-positioning actuator the plano-multiradius reflective element assembly is mounted, can be a fixedly attached exterior
15 sideview mirror assembly, a break-away exterior sideview mirror assembly and a powerfold exterior sideview mirror assembly, as known in the automotive mirror art.

Figs. 5A-5H shows various arrangements of multiradius reflective element 55 relative to its adjacent plano reflective element 50 (with demarcation element 65 disposed at their joint). In Figs. 5A, 5B, 5C, 5E and 5F, plano element 50 is mounted wholly inboard of
20 multiradius element 55. Thus, in Figs. 5A, 5B, 5C, 5E and 5F, plano element 50 would be disposed closer to the vehicle body (and hence to the driver) than multiradius element 55 when plano-multiradius reflective element assembly 30 was mounted in an exterior sideview mirror attached to a side of an automobile. Therefore, in Figs. 5A, 5B, 5C, 5E and 5F, plano element 50 would be mounted inboard relative to the side of the automobile and multiradius
25 element 55 would be mounted outboard relative to the side of the automobile. In general, the location of the multiradius reflective element in the outboard, upper portion of the plano-multiradius reflective element assembly, as in Figs. 5B and 5E, is preferred as this allows the plano portion provide a desired rearward field of view along the side of the vehicle. The configuration as shown in Fig. 5G (where the multiradius reflective element is along the
30 inboard side of the assembly) is also desirable as this allows the driver view the side of the vehicle (something many drivers desire in order to have a frame of reference for their rearward field of view) while facilitating having a wide field of view for the plano portion.

Unlike trucks, busses and commercial vehicles the size of an exterior sideview mirror assembly suitable for use on an automobile (and especially when the automobile is not towing a trailer or the like) is restricted. Automobiles generally are non-commercial vehicles intended for personal transportation. Automobiles typically carry 5 passengers or less, 5 although minivans and large sports utility vehicles (which are classified herein as automobiles) can have seat accommodation for up to 10 passengers (although accommodation for 7 passengers or less is more common). The tandem mounting of a plano element of unit magnification and a separate auxiliary element onto a common, single backing plate element, and the mounting of this backing plate element onto an actuator of an exterior sideview mirror assembly so that a driver can simultaneously and similarly move the 10 auxiliary element and the plano element so as to position their respective rearward fields of view, and to achieve this within the relatively restricted space available in a standard automobile-sized exterior sideview mirror assembly is an important element of this present invention. By utilizing a plano element of unit magnification in the plano-multiradius 15 reflective element assembly, and by sizing the reflector area of the plano element larger than the reflector area of the multiradius element and, preferably, by sizing the reflector area of the plano element at a sufficiently large size that the rearward field of view provided by the plano element alone meets and satisfies the minimum field of view requirement mandated by an automaker specification and/or a government regulation, the need to provide a safety warning 20 indicia such as "OBJECTS IN MIRROR ARE CLOSER THAN THEY APPEAR" in the plano element and/or in the multiradius element can be obviated. Preferably, the plano element comprises a reflector surface area of a size sufficient, when mounted as part of a plano-multiradius reflective element assembly in a driver-side exterior sideview mirror assembly on an automobile, to provide the driver of the automobile a view of a level road 25 surface extending to the horizon from a line, perpendicular to a longitudinal plane tangent to the driver's side of the automobile at the widest point, extending 8 feet out from the tangent plane 35 feet behind the driver's eyes (at a nominal location appropriate for any 95th percentile male driver or at the driver's eye reference points established in Federal Motor Vehicle Standard No. 104), with the driver seated in the driver's seat and with the driver's 30 seat in the rearmost position. Also, preferably, the aspect ratio of the plano-multiradius reflective element assembly (defined as the ratio of its largest vertical dimension to its largest horizontal dimension, measured with the plano-multiradius reflective element assembly

oriented as it would be oriented when mounted in an exterior sideview mirror assembly on an automobile, and with "horizontal" being generally parallel with the road surface the automobile travels on and "vertical" being generally perpendicular to the road surface the automobile travels on) is preferably less than 1, more preferably less than 0.8, most preferably less than 0.6. Further, it is preferable that the multiradius element be disposed outboard (relative to the side of the vehicle and with the plano-multiradius reflective element assembly oriented as it would be when mounted in an exterior sideview mirror assembly on an automobile) on the plano-multiradius reflective element assembly so that the multiradius element is positioned to provide an auxiliary, wide-angle view of a "blind-spot" region in an adjacent sidelane while the more inboard-disposed plano element with unit magnification provides the principal sideview image to the driver.

Also, it is preferable that the principal axis of the rearward field of view of the multiradius element be different from and angled to the principal axis of the rearward field of view of the plano element when both are attached to the backing plate element of the plano-multiradius reflective element assembly and when the plano-multiradius reflective element assembly is mounted and operated in an exterior sideview mirror assembly on an automobile. Preferably, the principal axis of the rearward field of view of the plano element is directed generally parallel to the road that the automobile equipped with the plano-multiradius reflective element assembly is travelling on (i.e. generally parallel to the longitudinal axis of the automobile) so as to provide the driver with a long-distance view of approaching vehicles in the side lane that the plano element views). However, preferably the principal axis of the rearward field of view of the multiradius element of, for example, a door-mounted driver-side (or passenger-side) exterior sideview mirror assembly in which the plano-multiradius reflective element assembly is mounted is directed generally downwardly towards the road surface adjacent to the driver seating location and/or several feet (such as about 1 foot to about 24 feet; more preferably, about 1 foot to about 12 feet; most preferably about 1 foot to about 8 feet in distance) to its rear (in order to capture a field of view of a rear approaching vehicle that is approaching to overtake, or is about to overtake, or is overtaking the automobile equipped with the plano-multiradius reflective element assembly). Thus, preferably, the principal axis of the rearward field of view of the multiradius element is angled and directed generally downwardly with respect to the longitudinal axis of the automobile and thus is at an angle to the principal axis of the rearward field of view of the

plano element. For example, multiradius element 155 when attached to surface 173 of backing plate 160 (see Fig. 6B) would have its principal axis of rearward view as indicated by 180 as in Fig. 6B, and as such would be canted towards the road surface when mounted in an exterior sideview mirror assembly attached to the side of an automobile. By contrast, 5 plano element 150 when attached to surface 174 of backing plate 160 (see Fig. 6A) would have a principal axis as indicated by 185 as in Fig. 6A and, as such, would be generally parallel to the road surface when mounted in an exterior sideview mirror assembly attached to the side of an automobile. Having the multiradius element canted somewhat downwards towards the road surface assists visual detection by the driver of overtaking vehicles in the 10 traditional "blind-spot" in the adjacent side lane. The angle that the multiradius element is angled on the backing plate element of the plano-multiradius reflective element assembly relative to the plane of the plano reflective element will vary from automobile model to model, but generally is preferred to be in the about 1 degree to about 10 degree range; about 2 degree to about 8 degree range more preferred; and about 3 degree to about 6 degree range 15 most preferred. In order to conveniently achieve an angling of the multiradius portion with respect to the plano portion (and preferably a downward angling), the portion of the backing plate element that the multiradius reflective element is attached to can be angled relative to the adjacent portion of the backing plate element that the plano reflective portion is attached to. Thus, and referring to Fig. 6, plano-multiradius reflective element assembly 130 includes 20 a molded polymeric backing plate element 160 comprising a generally flat portion 162 (between BB and CC in Fig. 6) and an adjacent curved portion 161 (between AA and BB). As indicated by 190 and 195, portion AA to BB of backing plate element 160 is generally angled to portion BB to CC of backing plate 160. Preferably, the portion of backing plate element 160 to which the auxiliary reflective element attaches is angled towards the front 25 (compared to the angling of plano reflective element) of an automobile equipped with the plano-auxiliary reflective element assembly of the present invention. Fig. 6 is a view of plano-multiradius reflective element assembly 130 as it would appear from above the vehicle as it would be orientated in use (with portion 162 closer to the driver than portion 161). The wall section, section XX in Fig. 6, taken through section 162 of backing plate element 160 is 30 of substantially constant dimension (as illustrated in Fig. 6A) whereas the wall section, section YY in Fig. 6B, taken through section 161 of backing plate element 160 is of varying dimension and is angled. Plano reflective element 150 and multiradius reflective element

155 (for example, plano element 150 can comprise an electrochromic mirror element and
multiradius element 155 can comprise a chrome coated glass reflector) are attached to
portions 162 and 161, respectively. By being supported on the angled face 173 (see Fig. 6B)
of portion 161, the principal viewing axis of multiradius reflector element 155 is angled
5 downwards towards the road surface, as compared to the more horizontal-viewing principal
viewing axis of plano element 150, when plano-multiradius reflective element 130 is
mounted in an exterior sideview mirror assembly on an automobile. Demarcation element
165 is preferably molded in the same molding tool as is used to mold backing plate element
160, and so demarcation element 165 is formed as an integral part of backing plate element
10 160, forming a wall thereof that partitions the surface of backing plate element 160 into a
region for receiving the plano reflective element 150 and a region for receiving the auxiliary
reflective element 155. Also, end-caps 170 and 171 are optionally provided. Plano reflective
element 150 can attach into the cavity formed between demarcation element 165 and end-cap
171; multiradius reflective element 155 can attach into the cavity formed between
15 demarcation element 165 and end-cap 170. Note that the portion of the backing plate element
where the wide-angle optic multiradius element attaches can have a thicker wall thickness
than that of the portion of the backing plate element where the unit magnification optic
element attaches in order to allow for the angling of the multiradius element downwardly
relative to the angle of the plano element, as illustrated in Figs. 6A-B. As illustrated in Figs.
20 6A-B, the angle downwards to the longitudinal axis of the vehicle of the multiradius element
can generally be set by an angling of a surface of the backing plate element in order to ensure
that the principal axis of the rearward field of view of the plano element is directed generally
parallel to the longitudinal axis of an automobile equipped with the plano-multiradius
reflective element assembly and that the principal axis of the rearward field of view of the
25 multiradius element is directed generally at an angle downwards to the longitudinal axis of
the automobile.

Note that the provision of the plano-multiradius reflective element assembly
of this invention as a unitary module has manufacturing advantages, particularly for exterior
sideview mirror assembly manufacturers who can procure a plano-multiradius reflective
30 element assembly module from a mirror reflector supplier and then mount the plano-
multiradius reflective element assembly module onto an actuator.

Referring to Fig. 7, a third embodiment 230 of a plano-multiradius reflective element assembly is illustrated. Plano-multiradius reflective element assembly 230 includes a plano reflective element 250 and a separate multiradius reflective element assembly 255, both individually attached to a backing plate element, and with demarcation element 265 disposed at their joint. Plano-multiradius reflective element assembly 230 is about 8.5 inches wide and about 4.25 inches tall (aspect ratio of 0.5), at their largest dimension. Shown as the shaded triangle 240 in plano reflective element 250 is the image of a triangular target object set about 35 feet rearward and of width about 8 feet and of height of about 4.1 feet as would be seen were plano-multiradius reflective element assembly 230 mounted in a driver-side exterior sideview mirror assembly in an automobile such as a sports utility vehicle. In general, it is desirable that the plano reflective element be dimensioned and configured so as to have its rearward field of view capture an image (that is visible, by reflection in the plano reflective element, to a driver seated in the driver's seat in an automobile to which is attached an exterior sideview mirror assembly equipped with the plano-auxiliary reflective element assembly according to this present invention) of a triangular shaped target located about 35 feet rearward of the driver seating location, extending about 8 feet out from the plane defined by the side of the automobile and reaching a height of between about 4 feet and about 5 feet from the road surface at that location 35 feet rearward of the automobile. The total field of view rearwardly of the vehicle of plano-multiradius reflective element assembly 230 (which is a combination of the field of view of plano reflective element 250 and of the auxiliary multiradius reflective element 255) preferably generally subtends an angle of at least about 30 degrees (and more preferably, generally subtends an angle of at least about 35 degrees and most preferably, generally subtends an angle of at least about 40 degrees) with respect to the side of an automobile to which is attached an exterior sideview mirror assembly equipped with plano-multiradius reflective element assembly 230.

Also, although it is preferable to utilize a multiradius or compound curvature reflective element such as an aspherical element or a compound curvature element for the auxiliary mirror element adjacent the plano reflective element (as this enables least discontinuity in image at the joint between the adjacent elements of the assembly), a spherical reflective element (that has substantially only one radius of curvature and, as such, is a section from a sphere) can optionally be used adjacent the plano reflective element instead of, or in addition to, the multiradius reflective element. Also, a plano auxiliary mirror

such as a flat mirrored substrate can be used, less preferably, as a substitute for a multiradius reflective element in those embodiments where the auxiliary reflective element is angled relative to the plane of the principal, plano reflective element so as to view a blind spot region of the principal plano element. Also, the plano-multiradius reflective element assembly can optionally be fixedly attached to an exterior sideview mirror assembly housing that is not movable, or, alternately, the exterior sideview mirror assembly housing to which the plano-multiradius reflective element assembly is fixedly attached can itself be actuated to move, such as by motor action, so that by moving the exterior sideview mirror assembly housing, the field of rearward view of the plano-multiradius reflective element assembly fixedly attached thereto can correspondingly move and be repositioned to suit the field of view need of a particular driver seated in the automobile cabin.

The above description is considered that of the preferred embodiments only. Modification of the invention will occur to those skilled in the art and to those who make or use the invention. Therefore, it is understood that the embodiments shown in the drawings and described above are merely for illustrative purposes and are not intended to limit the scope of the invention, which is defined in the following claims as interpreted according to the principles of patent law, including the doctrine of equivalents.

I claim:

1. An exterior sideview mirror system suitable for use in an automobile, said exterior sideview mirror system comprising:

an exterior sideview mirror assembly adapted for attachment to a side of an automobile;

5 said exterior sideview mirror assembly including a reflective element having a rearward field of view when attached to said side of the automobile;

said reflective element attached to an actuator and movable by said actuator in order to position said rearward field of view in response to a control;

10 wherein said reflective element comprises a plano-multiradius reflective element assembly, said plano-multiradius reflective element assembly comprising a plano reflective element having unit magnification and a separate multiradius reflective element having a multiradius curvature; and

15 said plano reflective element and said multiradius reflective element of said plano-multiradius reflective element assembly attached to a backing plate element, said backing plate element mounting to said actuator such that movement of said backing plate element of said plano-multiradius reflective element assembly by said actuator simultaneously and similarly moves said plano reflective element and said multiradius reflective element.

2. The exterior sideview mirror system of Claim 1, wherein said plano reflective element and said multiradius reflective element are adjacently attached to said backing plate element at a joint, and wherein said plano-multiradius reflective element assembly includes a demarcation element, said demarcation element disposed at said joint to form a demarcation
5 between said plano reflective element and said multiradius reflective element, said demarcation element having a portion visible to a driver of the automobile.

3. The exterior sideview mirror system of Claim 2, wherein said demarcation element is dark colored.

4. The exterior sideview mirror system of Claim 3, wherein said demarcation element is dark colored with a color selected from the group consisting of black, grey, blue and brown.
5. The exterior sideview mirror system of Claim 2, wherein said joint comprises a space between said plano reflective element and said multiradius reflective element.
6. The exterior sideview mirror system of Claim 5, wherein said demarcation element is at least partially disposed in said space between said plano reflective element and said multiradius reflective element.
7. The exterior sideview mirror system of Claim 3, wherein said demarcation element comprises at least one of a polymer material, a tape, a plastic film, a paint, a lacquer and a caulk.
8. The exterior sideview mirror system of Claim 7, wherein said demarcation element comprises a polymer material.
9. The exterior sideview mirror system of Claim 2, wherein said demarcation element comprises a wall on said backing plate element, said wall located on said backing plate element at said joint, said wall separating said plano reflective element from said multiradius reflective element.
10. The exterior sideview mirror system of Claim 2, wherein said portion visible to a driver of the automobile has a width less than about 4 mm.
11. The exterior sideview mirror system of Claim 2, wherein said portion visible to a driver of the automobile has a width less than about 3 mm.
12. The exterior sideview mirror system of Claim 2, wherein said portion visible to a driver of the automobile has a width less than about 2 mm.

13. The exterior sideview mirror system of Claim 2, wherein said portion visible to a driver of the automobile has a width greater than about 0.5 mm.

14. The exterior sideview mirror system of Claim 2, wherein said portion visible to a driver of the automobile has a width greater than about 0.75 mm.

15. The exterior sideview mirror system of Claim 2, wherein said portion visible to a driver of the automobile has a width greater than about 1 mm.

16. The exterior sideview mirror system of Claim 1, wherein said plano reflective element is attached to said backing plate element by at least one of an adhesive attachment and a mechanical attachment.

17. The exterior sideview mirror system of Claim 1, wherein said multiradius reflective element is attached to said backing plate element by at least one of an adhesive attachment and a mechanical attachment.

18. The exterior sideview mirror system of Claim 1, wherein said multiradius reflective element is attached to said backing plate element at a location such that, when said exterior mirror assembly is attached to a side of an automobile, at least a portion of said plano reflective element is disposed closer to said side of the automobile than any portion of said
5 multiradius reflective element.

19. The exterior sideview mirror system of Claim 1, wherein said multiradius reflective element comprises a bent glass substrate with radii of curvature in the range of from about 4000 mm to about 50 mm.

20. The exterior sideview mirror system of Claim 1, wherein the ratio of the width of said plano reflective element to the width of said multiradius reflective element is greater than 1.

21. The exterior sideview mirror system of Claim 1, wherein the ratio of the width of said plano reflective element to the width of said multiradius reflective element is greater than 1.5.

22. The exterior sideview mirror system of Claim 1, wherein the ratio of the width of said plano reflective element to the width of said multiradius reflective element is greater than 2.5.

23. The exterior sideview mirror system of Claim 1, wherein the principal axis of the rearward field of view of said multiradius reflective element is different from and angled to the principal axis of the rearward field of view of said plano reflective element when both are attached to said backing plate element of said plano-multiradius reflective element
5 assembly and when said plano-multiradius reflective element assembly is mounted in said exterior sideview mirror assembly on an automobile.

24. The exterior sideview mirror system of Claim 23, wherein the principal axis of the rearward field of view of said plano reflective element is directed generally parallel to the longitudinal axis of an automobile equipped with the plano-multiradius reflective element assembly and wherein the principal axis of the rearward field of view of said multiradius
5 reflective element is directed generally at an angle downwards to the longitudinal axis of the automobile.

25. The exterior sideview mirror system of Claim 24, wherein said angle downwards to the longitudinal axis of the automobile is in the range from about 1 degree to about 10 degrees.

26. The exterior sideview mirror system of Claim 24, wherein said angle downwards to the longitudinal axis of the automobile is in the range from about 2 degrees to about 8 degrees.

27. The exterior sideview mirror system of Claim 24, wherein said angle downwards to the longitudinal axis of the automobile is in the range from about 3 degrees to about 6 degrees.

28. The exterior sideview mirror system of Claim 24, wherein said angle downwards to the longitudinal axis of the automobile is generally set by an angling of a surface of said backing plate element.

29. The exterior sideview mirror system of Claim 24, wherein said exterior sideview mirror assembly comprises a door-mounted exterior sideview mirror assembly adapted for attachment to a side of the automobile adjacent a driver seating location of a driver of the automobile and wherein the principal axis of the rearward field of view of said
5 multiradius reflective element is directed generally downwardly towards the road surface adjacent to the driver seating location at a distance in the range of about 1 foot to about 24 feet to the rear of the driver seating location.

30. The exterior sideview mirror system of Claim 24, wherein said exterior sideview mirror assembly comprises a door-mounted exterior sideview mirror assembly adapted for attachment to a side of the automobile adjacent a driver seating location of a driver of the automobile and wherein the principal axis of the rearward field of view of said
5 multiradius reflective element is directed generally downwardly towards the road surface adjacent to the driver seating location at a distance in the range of about 1 foot to about 12 feet to the rear of the driver seating location.

31. The exterior sideview mirror system of Claim 24, wherein said exterior sideview mirror assembly comprises a door-mounted exterior sideview mirror assembly adapted for attachment to a side of the automobile adjacent a driver seating location of a driver of the automobile and wherein the principal axis of the rearward field of view of said
5 multiradius reflective element is directed generally downwardly towards the road surface adjacent to the driver seating location at a distance in the range of about 1 foot to about 8 feet to the rear of the driver seating location.

32. The exterior sideview mirror system of Claim 1, wherein said exterior sideview mirror assembly comprises a fixedly attached exterior sideview mirror assembly.
33. The exterior sideview mirror system of Claim 1, wherein said exterior sideview mirror assembly comprises a break-away exterior sideview mirror assembly.
34. The exterior sideview mirror system of Claim 1, wherein said exterior sideview mirror assembly comprises a powerfold exterior sideview mirror assembly.
35. The exterior sideview mirror system of Claim 1, wherein said actuator comprises an electrically operable actuator.
36. The exterior sideview mirror system of Claim 1, wherein said control comprises a memory controller.
37. The exterior sideview mirror system of Claim 1, wherein at least one of said plano reflective element and said multiradius reflective element comprises an electro-optic reflective element.
38. The exterior sideview mirror system of Claim 1, wherein both said plano reflective element and said multiradius reflective element comprise an electro-optic reflective element.
39. The exterior sideview mirror system of Claim 1, wherein said plano reflective element comprises an electro-optical reflective element.
40. The exterior sideview mirror system of Claim 39, wherein said electro-optical reflective element comprises an electrochromic reflective element.
41. The exterior sideview mirror system of Claim 40, wherein said multiradius reflective element comprises a fixed reflectance mirror reflector.

42. The exterior sideview mirror system of Claim 41, wherein said fixed reflectance mirror reflector comprises a bent glass substrate coated with a metallic reflector coating.

43. The exterior sideview mirror system of Claim 1, wherein said plano-multiradius reflective element assembly is formed in an integral molding operation.

44. An exterior sideview mirror system suitable for use in an automobile, said exterior sideview mirror system comprising:

an exterior sideview mirror assembly adapted for attachment to a side of an automobile;

5 said exterior sideview mirror assembly including a reflective element having a rearward field of view when attached to said side of the automobile;

said reflective element attached to an electrically operable actuator and movable by said actuator in order to position said rearward field of view in response to a control;

10 wherein said reflective element comprises a plano reflective element having unit magnification and a separate auxiliary reflective element;

said plano reflective element and said auxiliary reflective element attached to a backing plate element, said backing plate element mounting to said actuator such that movement of said backing plate element by said actuator simultaneously and similarly moves
15 said plano reflective element and said auxiliary reflective element; and

wherein said plano reflective element and said auxiliary reflective element are adjacently attached to said backing plate element at a joint, and wherein a demarcation element is disposed at said joint to form a demarcation between said plano reflective element and said auxiliary reflective element, said demarcation element having a portion visible to a
20 driver of the automobile.

45. The exterior sideview mirror system of Claim 44, wherein demarcation element is dark colored.

46. The exterior sideview mirror system of Claim 44, wherein said demarcation element is dark colored with a color selected from the group consisting of black, grey, blue and brown.
47. The exterior sideview mirror system of Claim 44, wherein said joint comprises a space between said plano reflective element and said auxiliary reflective element.
48. The exterior sideview mirror system of Claim 47, wherein said demarcation element is at least partially disposed in said space between said plano reflective element and said auxiliary reflective element.
49. The exterior sideview mirror system of Claim 44, wherein said demarcation element comprises at least one of a polymer material, a tape, a plastic film, a paint, a lacquer and a caulk.
50. The exterior sideview mirror system of Claim 44, wherein said demarcation element comprises a polymer material.
51. The exterior sideview mirror system of Claim 44, wherein said demarcation element comprises a wall on said backing plate element, said wall located on said backing plate element at said joint, said wall separating said plano reflective element from said auxiliary reflective element.
52. The exterior sideview mirror system of Claim 44, wherein said portion visible to a driver of the automobile has a width less than about 4 mm.
53. The exterior sideview mirror system of Claim 44, wherein said portion visible to a driver of the automobile has a width less than about 3 mm.
54. The exterior sideview mirror system of Claim 44, wherein said portion visible to a driver of the automobile has a width less than about 2 mm.

55. The exterior sideview mirror system of Claim 44, wherein said portion visible to a driver of the automobile has a width greater than about 0.5 mm.

56. The exterior sideview mirror system of Claim 44, wherein said portion visible to a driver of the automobile has a width greater than about 0.75 mm.

57. The exterior sideview mirror system of Claim 44, wherein said portion visible to a driver of the automobile has a width greater than about 1 mm.

58. The exterior sideview mirror system of Claim 44, wherein said plano reflective element is attached to said backing plate element by at least one of an adhesive attachment and a mechanical attachment.

59. The exterior sideview mirror system of Claim 44, wherein said auxiliary reflective element is attached to said backing plate element by at least one of an adhesive attachment and a mechanical attachment.

60. The exterior sideview mirror system of Claim 44, wherein said auxiliary reflective element is attached to said backing plate element at a location such that, when said exterior mirror assembly is attached to a side of an automobile, at least a portion of said plano reflective element is disposed closer to said side of the automobile than any portion of said auxiliary reflective element.

61. The exterior sideview mirror system of Claim 44, wherein said auxiliary reflective element comprises one of a flat glass substrate and a bent glass substrate

62. The exterior sideview mirror system of Claim 44, wherein the ratio of the width of said plano reflective element to the width of said auxiliary reflective element is greater than 1.

63. The exterior sideview mirror system of Claim 44, wherein the ratio of the width of said plano reflective element to the width of said auxiliary reflective element is greater than 1.5.

64. The exterior sideview mirror system of Claim 44, wherein the ratio of the width of said plano reflective element to the width of said auxiliary reflective element is greater than 2.5.

65. The exterior sideview mirror system of Claim 44, wherein the principal axis of the rearward field of view of said auxiliary reflective element is different from and angled to the principal axis of the rearward field of view of said plano reflective element when both are attached to said backing plate element and are mounted in said exterior sideview mirror
5 assembly on an automobile.

66. The exterior sideview mirror system of Claim 65, wherein the principal axis of the rearward field of view of said plano reflective element is directed generally parallel to the longitudinal axis of an automobile equipped with said reflective element and wherein the principal axis of the rearward field of view of said auxiliary reflective element is directed
5 generally at an angle downwards to the longitudinal axis of an automobile equipped with said reflective element.

67. The exterior sideview mirror system of Claim 66, wherein said angle downwards to the longitudinal axis of the automobile is in the range from about 1 degree to about 10 degrees.

68. The exterior sideview mirror system of Claim 66, wherein said angle downwards to the longitudinal axis of the automobile is in the range from about 2 degrees to about 8 degrees.

69. The exterior sideview mirror system of Claim 66, wherein said angle downwards to the longitudinal axis of the automobile is in the range from about 3 degrees to about 6 degrees.

70. The exterior sideview mirror system of Claim 66, wherein said angle downwards to the longitudinal axis of the automobile is generally set by an angling of a surface of said backing plate element.

71. The exterior sideview mirror system of Claim 66, wherein said exterior sideview mirror assembly comprises a door-mounted exterior sideview mirror assembly adapted for attachment to a side of the automobile adjacent a driver seating location of a driver of the automobile and wherein the principal axis of the rearward field of view of said
5 auxiliary reflective element is directed generally downwardly towards the road surface adjacent to the driver seating location at a distance in the range of about 1 foot to about 24 feet to the rear of the driver seating location.

72. The exterior sideview mirror system of Claim 66, wherein said exterior sideview mirror assembly comprises a door-mounted exterior sideview mirror assembly adapted for attachment to a side of the automobile adjacent a driver seating location of a driver of the automobile and wherein the principal axis of the rearward field of view of said
5 auxiliary reflective element is directed generally downwardly towards the road surface adjacent to the driver seating location at a distance in the range of about 1 foot to about 12 feet to the rear of the driver seating location.

73. The exterior sideview mirror system of Claim 66, wherein said exterior sideview mirror assembly comprises a door-mounted exterior sideview mirror assembly adapted for attachment to a side of the automobile adjacent a driver seating location of a driver of the automobile and wherein the principal axis of the rearward field of view of said
5 auxiliary reflective element is directed generally downwardly towards the road surface adjacent to the driver seating location at a distance in the range of about 1 foot to about 8 feet to the rear of the driver seating location.

74. The exterior sideview mirror system of Claim 44, wherein said exterior sideview mirror assembly comprises a fixedly attached exterior sideview mirror assembly.

75. The exterior sideview mirror system of Claim 44, wherein said exterior sideview mirror assembly comprises a break-away exterior sideview mirror assembly.
76. The exterior sideview mirror system of Claim 44, wherein said exterior sideview mirror assembly comprises a powerfold exterior sideview mirror assembly.
77. The exterior sideview mirror system of Claim 44, wherein said control comprises a memory controller.
78. The exterior sideview mirror system of Claim 44, wherein at least one of said plano reflective element and said auxiliary reflective element comprises an electro-optic reflective element.
79. The exterior sideview mirror system of Claim 44, wherein both said plano reflective element and said auxiliary reflective element comprise an electro-optic reflective element.
80. The exterior sideview mirror system of Claim 44, wherein said plano reflective element comprises an electro-optical reflective element.
81. The exterior sideview mirror system of Claim 80, wherein said electro-optical reflective element comprises and electrochromic reflective element.
82. The exterior sideview mirror system of Claim 81, wherein said auxiliary reflective element comprises a fixed reflectance mirror reflector.
83. The exterior sideview mirror system of Claim 82, wherein said fixed reflectance mirror reflector comprises a bent glass substrate coated with a metallic reflector coating.

EXTERIOR MIRROR PLANO-AUXILIARY REFLECTIVE ELEMENT ASSEMBLY

ABSTRACT

This invention provides a plano-multiradius reflective element assembly suitable for use in an exterior sideview mirror assembly mounted to the side body of an automobile. The plano-multiradius reflective element assembly includes a plano reflective element which has a rearward field of view, when mounted in an exterior sideview mirror assembly mounted to the side body of an automobile, with unit magnification. The plano-multiradius reflective element assembly also includes an auxiliary reflective element including a multiradius portion with a rearward field of view. The plano reflective element provides a distortion-free rearward field of view and serves as the principal rearward-viewing portion of the plano-multiradius reflective element assembly. The multiradius portion provides a wide angle rearward field of view, and typically supplements the rearward field of view of the plano portion. The plano reflective element and the multiradius portion are separated by a demarcation element which enables the driver to readily delineate a rearward view in the plano portion from a rearward view in the multiradius portion. The plano reflective element and the multiradius reflective element are individually, separately, and adjacently attached to a single backing plate which is mounted to an actuator of the exterior sideview mirror assembly. By adjusting the position of the backing plate within the housing of the exterior sideview mirror assembly via the actuator, the rearward field of view of both the plano reflective element and the multiradius reflective element are simultaneously and similarly aligned.

DON01 P-793

Express Mail No. EL399135945US

DECLARATION AND POWER OF ATTORNEY

As a below named inventor, I hereby declare:

My residence, post office address and citizenship are as stated below next to my name.

I believe I am the original, first and sole inventor, if only one name is listed below, or an original, first and joint inventor, if plural names are listed below, of the subject matter which is claimed and for which a patent is sought on the invention entitled EXTERIOR MIRROR PLANO-AUXILIARY REFLECTIVE ELEMENT ASSEMBLY, the specification of which is attached hereto.

I have reviewed and understand the contents of the above-identified specification, including the claims, as amended by any amendment referred to above.

I acknowledge the duty to disclose to the United States Patent and Trademark Office (the Office), all information which is known by me to be material to patentability as defined in Title 37, Code of Federal Regulations (C.F.R.), Section 1.56.

CLAIM OF PRIORITY

I hereby claim foreign benefits under Title 35, United States Code (U.S.C.), Section 119, of any foreign application(s) for patent or inventor's certificate listed below and have also identified below any foreign application for patent or inventor's certificate having a filing date before that of the application on which priority is claimed.

Application Ser. No. None, filed in (country) _____ on _____.

I hereby claim the benefit under 35 U.S.C. § 120, of any United States application(s) listed below and, insofar as the above-identified specification, including claims, discloses and claims subject matter in addition to that disclosed in the prior pending application(s), listed below, I acknowledge the duty to disclose to the Office, all information which is known by me to be material to patentability as defined in 37 C.F.R. § 1.56, which became available between the filing date of the prior application and the national or PCT international filing date of this application.

U.S. Serial No. None, filed on _____, and now (status) _____.

I hereby claim the benefit under Title 35, United States Code, § 119(e) of any United States provisional application(s) listed below:

U.S. Serial No. None, filed on _____.

POWER OF ATTORNEY

I hereby appoint the patent law firm of Van Dyke, Gardner, Linn & Burkhardt, LLP, 2851 Charlevoix Drive, S.E., Suite 207, Grand Rapids, Michigan 49546, telephone number 616/975-5500, facsimile number 616/975-5505, and the individual patent attorneys and patent agents at such patent law firm, namely, Daniel Van Dyke, Reg. No. 25 046; Donald S. Gardner, Reg. No. 25 975; Terence J. Linn, Reg. No. 30 283; Frederick S. Burkhardt, Reg. No. 29 288; Catherine S. Collins, Reg. No. 37 599; Matthew L. Goska, Reg. No. 42 594; Anthony A. Bisulca, Reg. No. 40 913; and Timothy A. Flory, Reg. No. 42 540, my attorney(s) or agent(s) with full power of substitution and revocation, to prosecute this application and to transact all business in and to receive all correspondence from the Patent and Trademark Office connected therewith.

All statements made herein of my own knowledge are true and all statements made on information and belief are believed to be true, and further, these statements are made with the knowledge that willful false statements and the like are punishable by fine or imprisonment, or both, under 18 U.S.C. § 1001, and that such willful false statements may jeopardize the validity of this application or any patent issued thereon.

Sole inventor:

Niall R. Lynam JAN 6 2000
Niall R. Lynam Date

Citizenship: USA

Residence: 248 Foxdown

Holland, Michigan 49424

Post Office Address: Same as above.

10

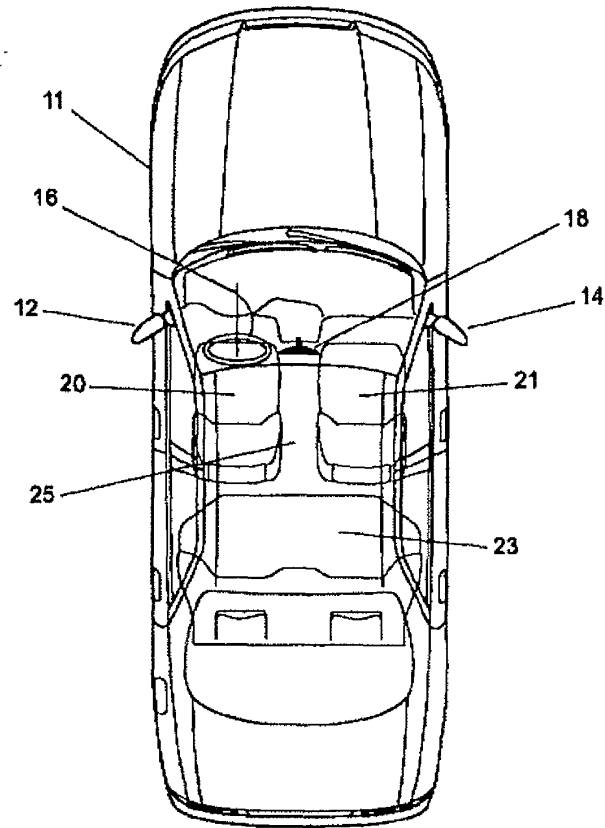

Figure 1

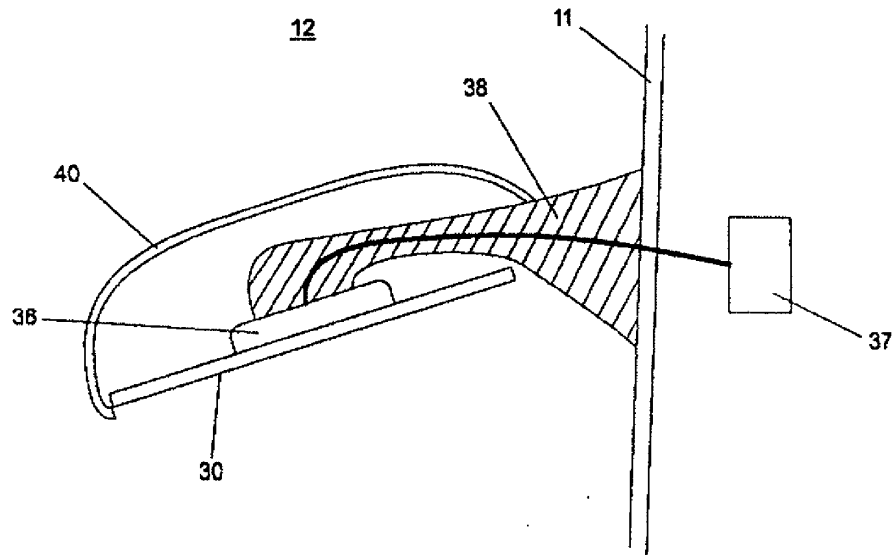

Figure 2

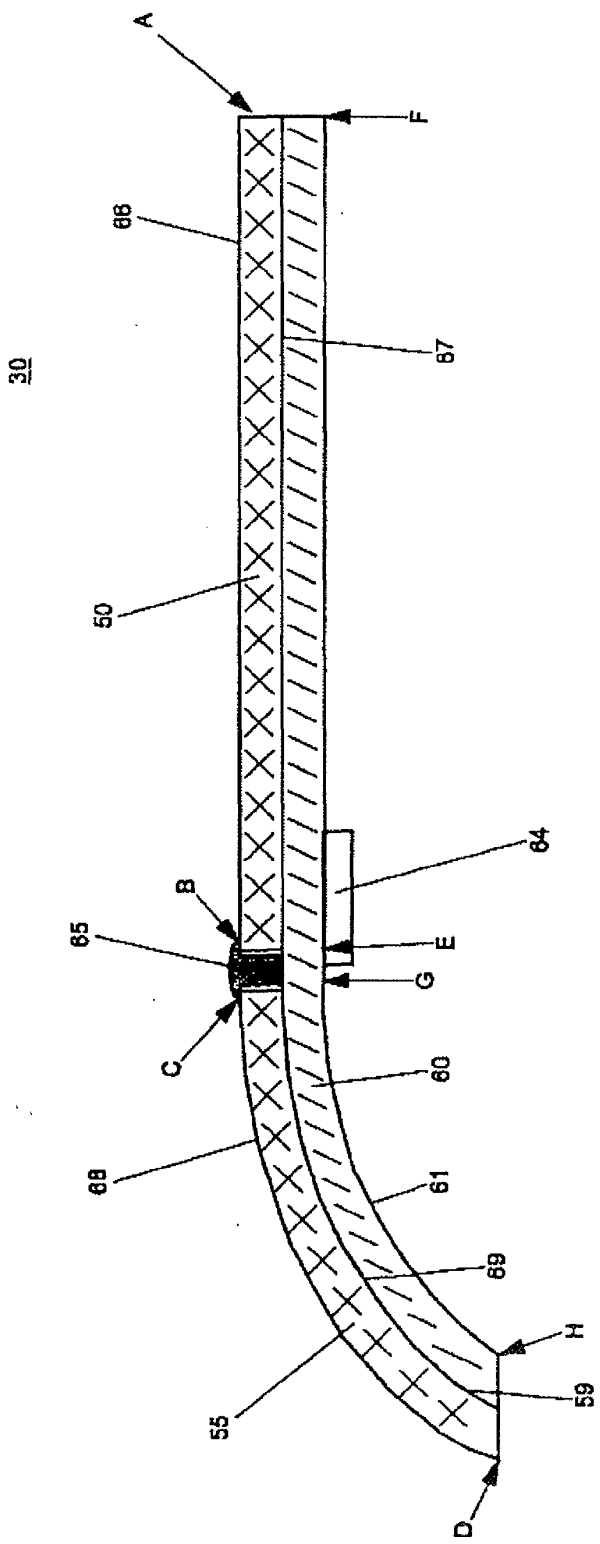

Figure 3

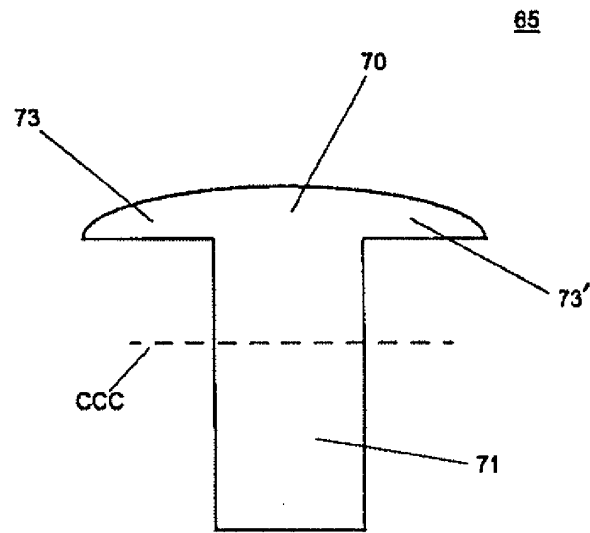

Figure 4

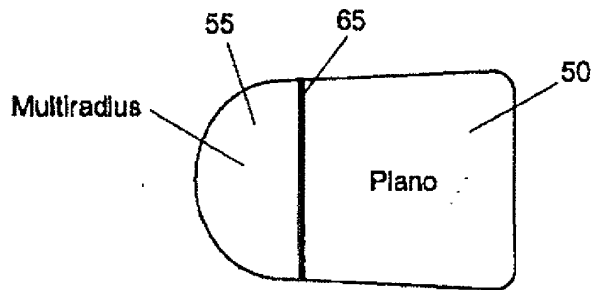

FIG. 5A

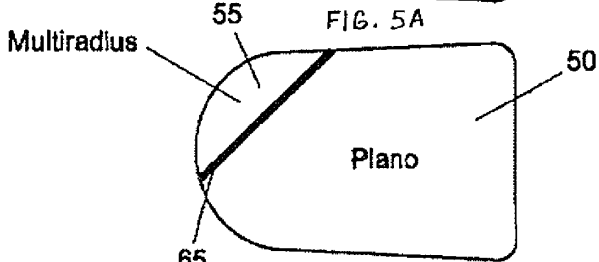

FIG. 5B

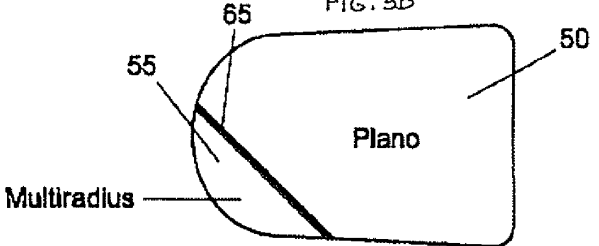

FIG. 5C

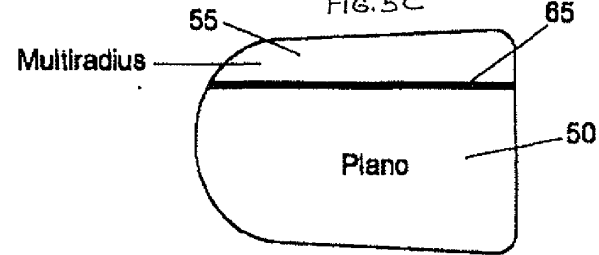

FIG. 5D

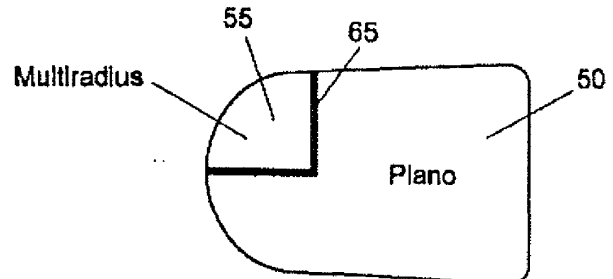

FIG. 5E

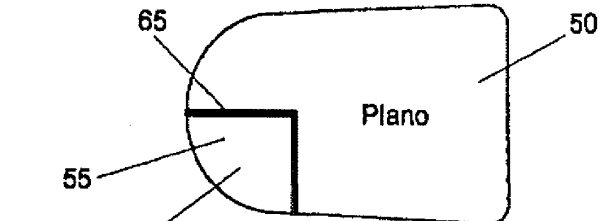

FIG. 5F

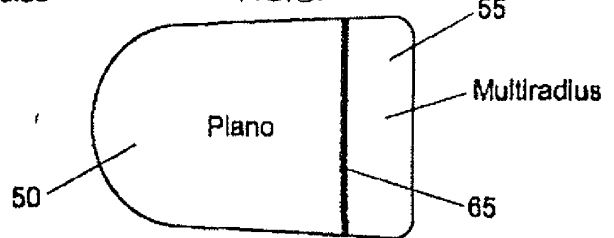

FIG. 5G

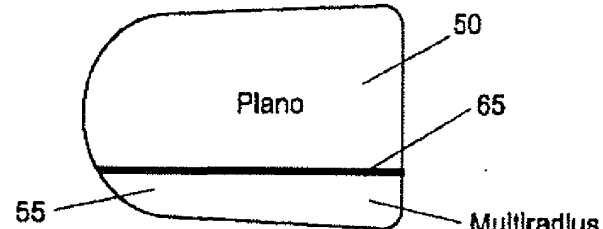

FIG. 5H

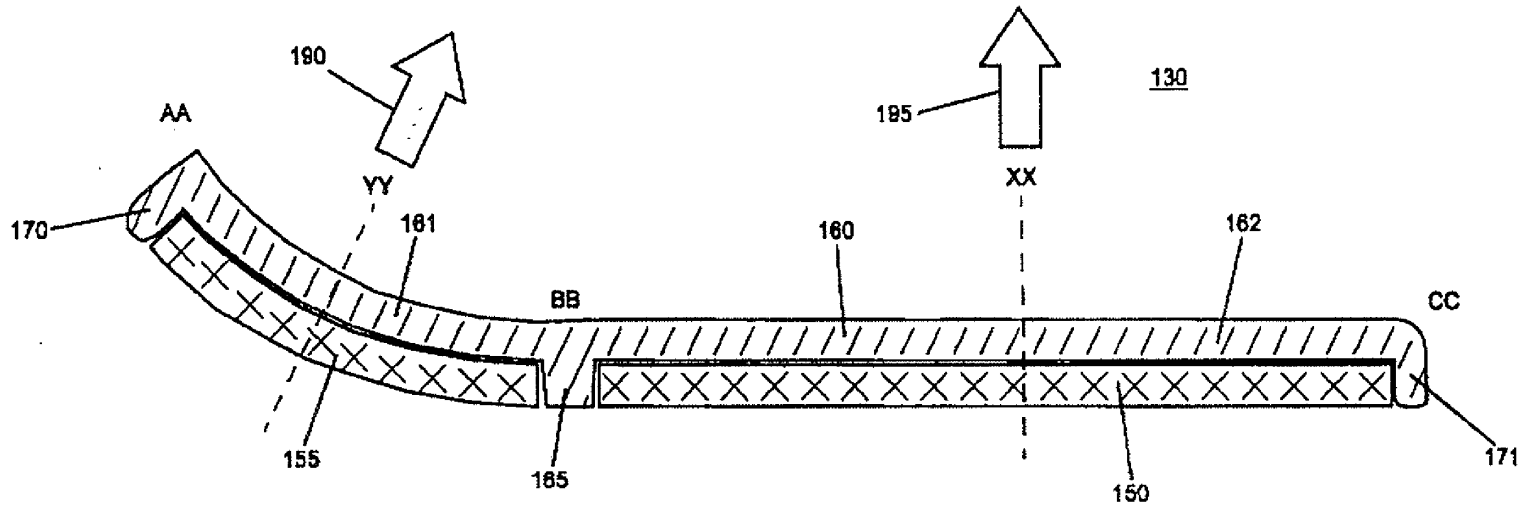

Figure 6

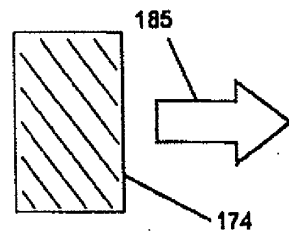

Figure 6A

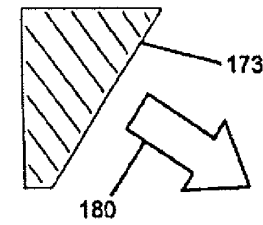

Figure 6B

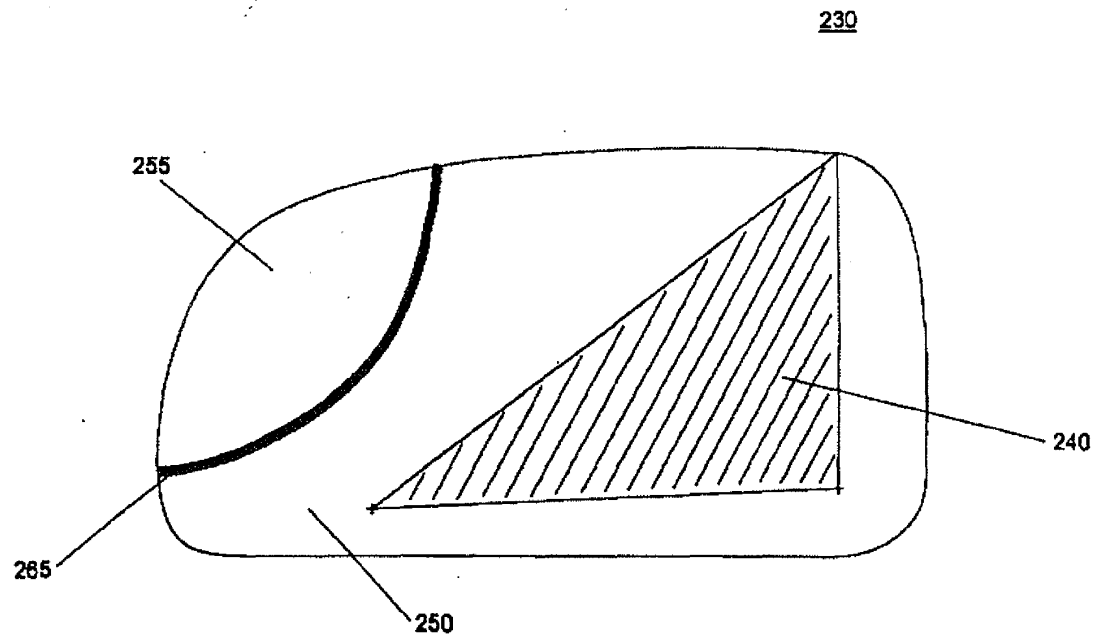

Figure 7



US006522451B1

(12) **United States Patent**
Lynam

(10) **Patent No.:** **US 6,522,451 B1**
(45) **Date of Patent:** **Feb. 18, 2003**

(54) **EXTERIOR MIRROR PLANO-AUXILIARY REFLECTIVE ELEMENT ASSEMBLY**

- (75) Inventor: **Niall R. Lynam**, Holland, MI (US)
- (73) Assignee: **Donnelly Corporation**, Holland, MI (US)
- (*) Notice: Subject to any disclaimer, the term of this patent is extended or adjusted under 35 U.S.C. 154(b) by 0 days.

- (21) Appl. No.: **09/478,315**
- (22) Filed: **Jan. 6, 2000**
- (51) Int. Cl.⁷ **G02F 1/15**; G02B 5/08; G02B 5/10; G02B 7/182; B60R 1/06
- (52) U.S. Cl. **359/265**; 359/267; 359/841; 359/850; 359/864; 359/866; 359/868; 359/872; 359/877; 248/549; 248/900
- (58) Field of Search 359/841, 850, 359/851, 855, 864, 865, 866, 868, 872, 877, 265, 267; 248/549, 900

(56) **References Cited**

U.S. PATENT DOCUMENTS

2,911,177	A	*	11/1959	West	
3,104,274	A	*	9/1963	King	359/864
3,170,985	A	*	2/1965	Katulich	
3,375,053	A		5/1968	Ward	350/293
3,389,952	A	*	6/1968	Tobin, Jr.	359/864
3,764,201	A	*	10/1973	Haile	

(List continued on next page.)

FOREIGN PATENT DOCUMENTS

DE	2409748		9/1975		
DE	3302735	*	8/1984		359/866
DE	4026578	*	4/1992		359/850
EP	0210757	*	2/1987		359/864
EP	0310261	A1	4/1989		
EP	0551802	*	1/1992		359/864

(List continued on next page.)

OTHER PUBLICATIONS

U.S. Pat. Ser. No. 09/350,930, filed Jul. 12, 1999, entitled Electrochromic Polymer Solid Films, Manufacturing Electrochromic Devices Using Such Films, and Processes for Making Such Solid Films and Devices, by Applicants Desraj V. Varaprasad et al.

Primary Examiner—Ricky D. Shafer
(74) *Attorney, Agent, or Firm*—Van Dyke, Gardner, Linn & Burkhart, LLP

(57) **ABSTRACT**

This invention provides a plano-multiradius reflective element assembly suitable for use in an exterior sideview mirror assembly mounted to the side body of an automobile. The plano-multiradius reflective element assembly includes a plano reflective element which has a rearward field of view, when mounted in an exterior sideview mirror assembly mounted to the side body of an automobile, with unit magnification. The plano-multiradius reflective element assembly also includes an auxiliary reflective element including a multiradius portion with a rearward field of view. The plano reflective element provides a distortion-free rearward field of view and serves as the principal rearward-viewing portion of the plano-multiradius reflective element assembly. The multiradius portion provides a wide angle rearward field of view, and typically supplements the rearward field of view of the plano portion. The plano reflective element and the multiradius portion are separated by a demarcation element which enables the driver to readily delineate a rearward view in the plano portion from a rearward view in the multiradius portion. The plano reflective element and the multiradius reflective element are individually, separately, and adjacently attached to a single backing plate which is mounted to an actuator of the exterior sideview mirror assembly. By adjusting the position of the backing plate within the housing of the exterior sideview mirror assembly via the actuator, the rearward field of view of both the plano reflective element and the multiradius reflective element are simultaneously and similarly aligned.

40 Claims, 8 Drawing Sheets

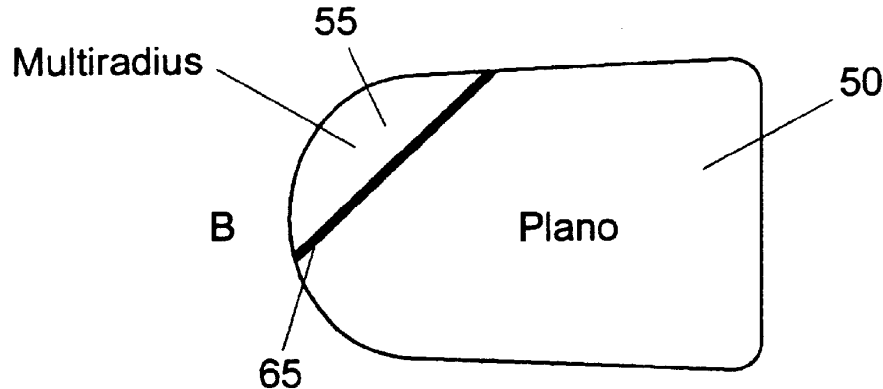

EXHIBIT B

US 6,522,451 B1

Page 2

U.S. PATENT DOCUMENTS

4,258,979	A	*	3/1981	Mahin	359/868
4,268,120	A		5/1981	Jitsumori	350/302
4,281,899	A	*	8/1981	Oskam		
4,306,770	A	*	12/1981	Marhauer	359/866
4,311,362	A	*	1/1982	LaPorte	359/864
4,331,382	A	*	5/1982	Graff	359/868
4,449,786	A		5/1984	McCord	350/293
4,555,166	A	*	11/1985	Enomoto	359/877
4,678,294	A	*	7/1987	Van Nostrand	359/864
4,727,302	A	*	2/1988	Mizuta et al.	359/877
4,770,522	A	*	9/1988	Alten	359/877
4,859,046	A	*	8/1989	Traynor et al.	359/866
4,917,485	A	*	4/1990	Baldwin, Sr.		
5,005,962	A	*	4/1991	Edelman	359/864
5,052,792	A	*	10/1991	McDonough	359/866
5,107,374	A	*	4/1992	Lupo et al.	359/841
5,115,352	A	*	5/1992	Do Espirito Santo	359/864
5,166,833	A	*	11/1992	Shyu		
5,225,943	A	*	7/1993	Lupo	359/841
5,239,405	A		8/1993	Varaprasad et al.	359/272
5,432,643	A	*	7/1995	Huang	359/864
5,550,677	A		8/1996	Schofield et al.	359/604

5,579,133	A	*	11/1996	Black et al.	359/866
5,621,569	A	*	4/1997	Schlenke	359/868
5,668,663	A		9/1997	Varaprasad et al.	359/608
5,724,187	A		3/1998	Varaprasad et al.	359/608
5,751,489	A		5/1998	Caskey et al.	359/603
5,793,542	A	*	8/1998	Kondo et al.	359/866
5,796,532	A	*	8/1998	Kanazawa	359/864
5,910,854	A		6/1999	Varaprasad et al.	359/273
6,032,323	A	*	3/2000	Smith et al.	359/877
6,199,993	B1	*	3/2001	Mou	359/864

FOREIGN PATENT DOCUMENTS

FR	2628042		9/1929			
GB	1279158	*	6/1972		359/868
GB	2048189	*	12/1980		359/868
GB	2092534	*	8/1982		359/868
JP	0051637	*	4/1980		359/866
JP	62-105103	*	5/1987			
JP	1186443		7/1989			
JP	1-208245	*	8/1989		359/871
NL	7908257	*	6/1981		359/864

* cited by examiner

10

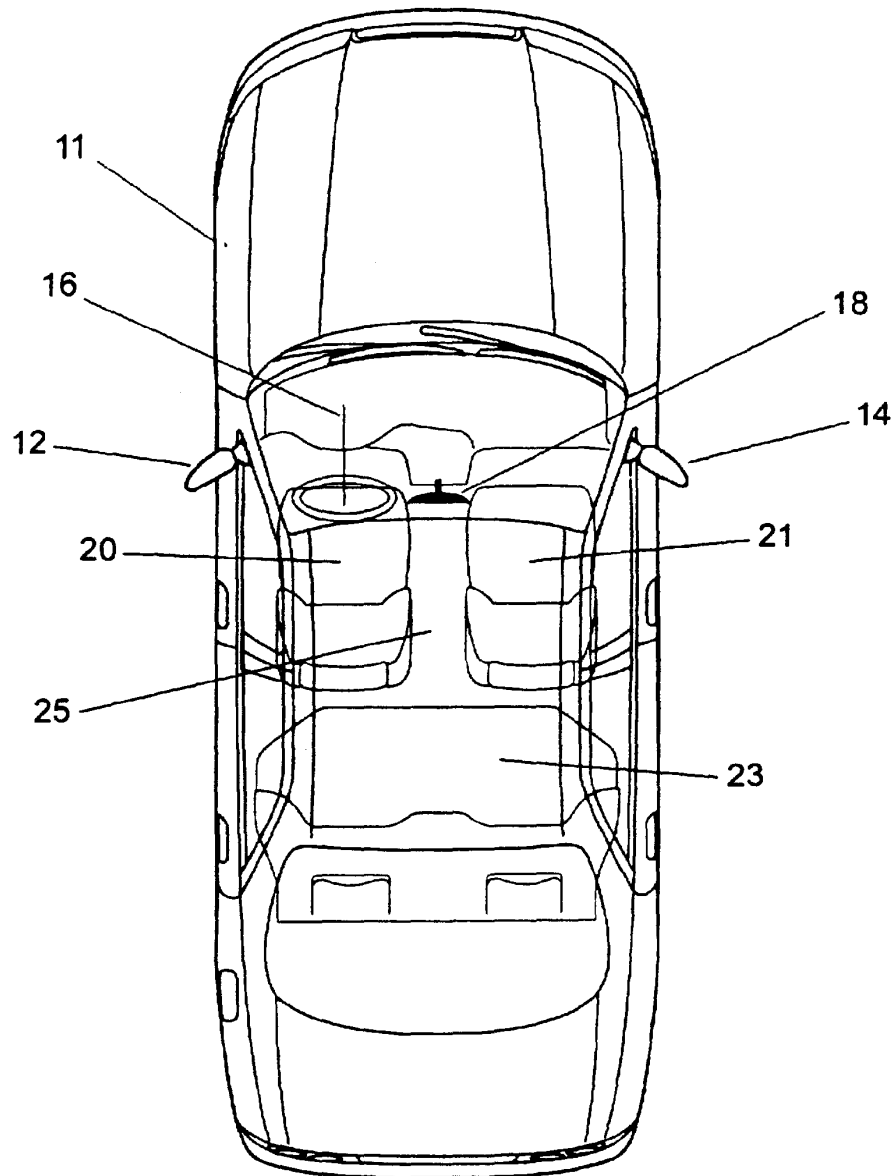

Figure 1

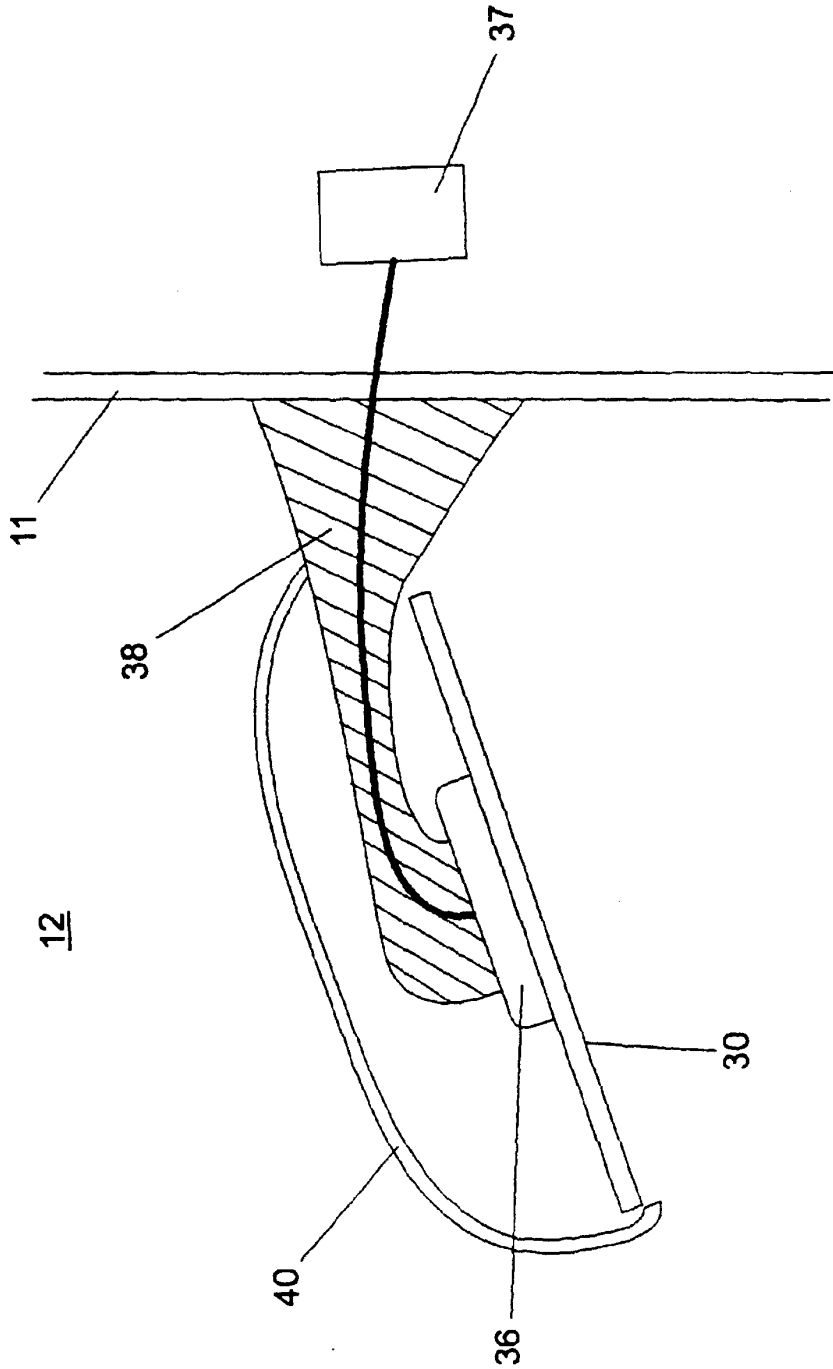

Figure 2

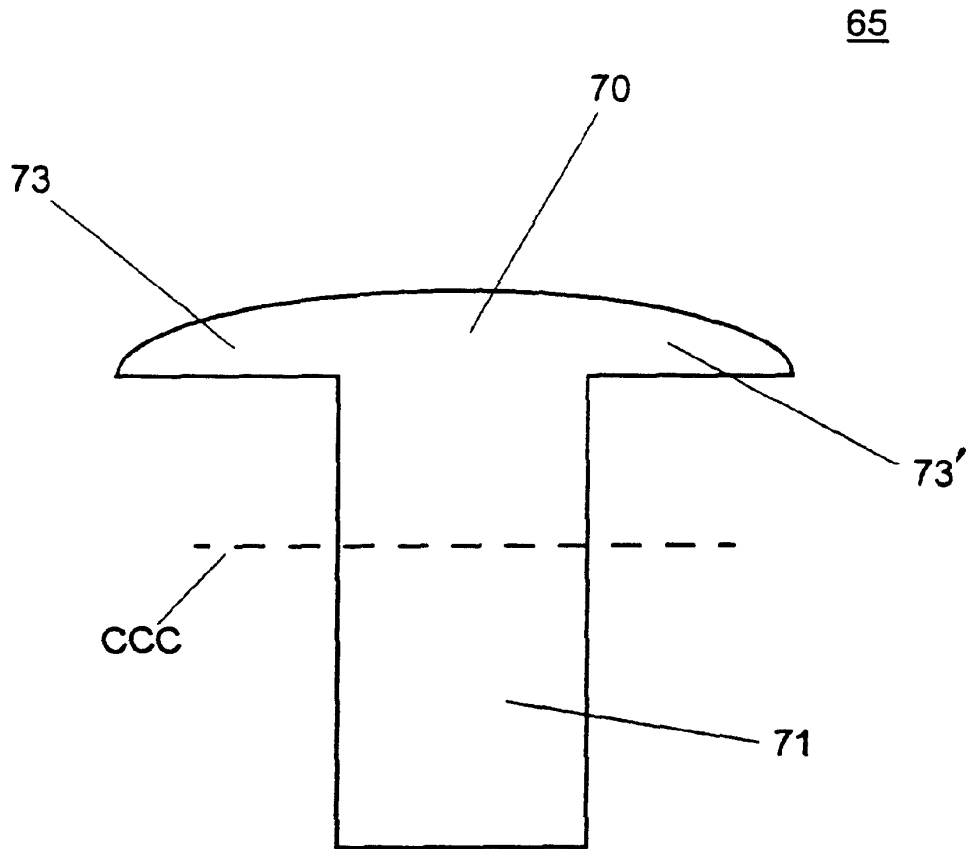
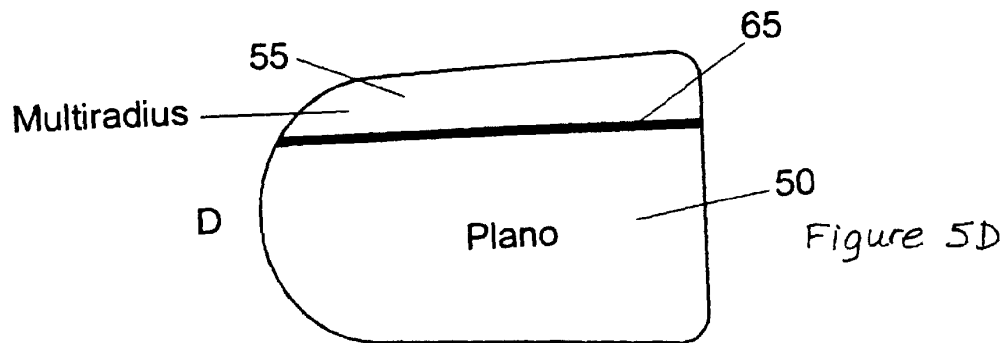
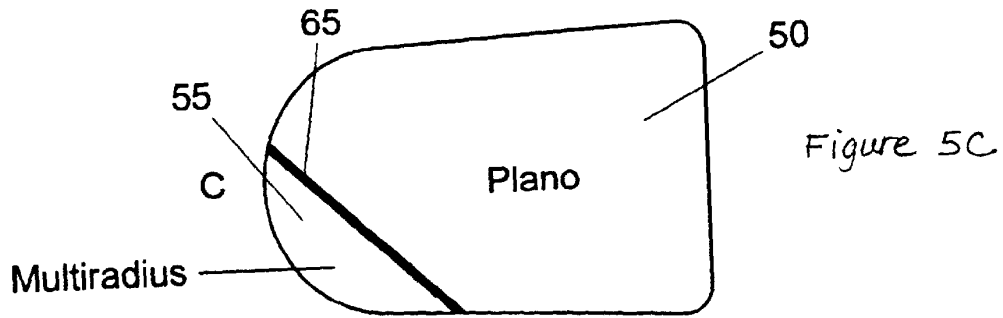
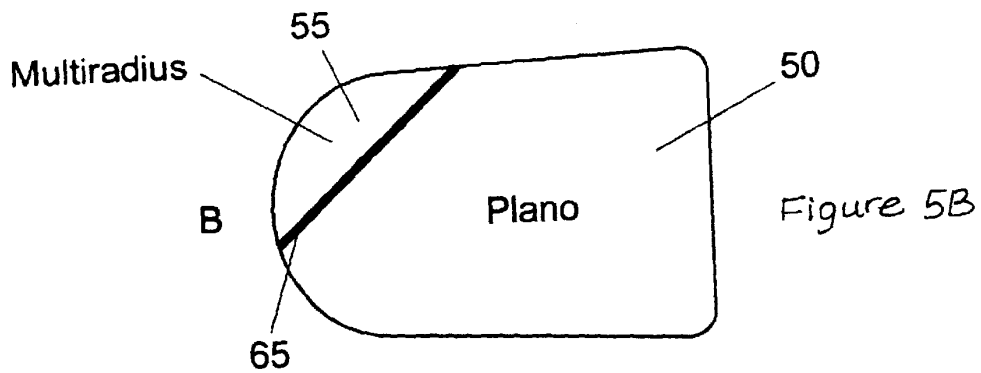
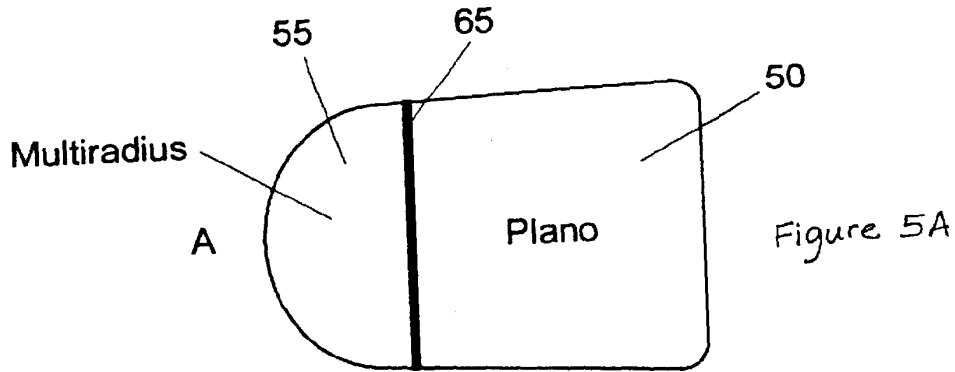
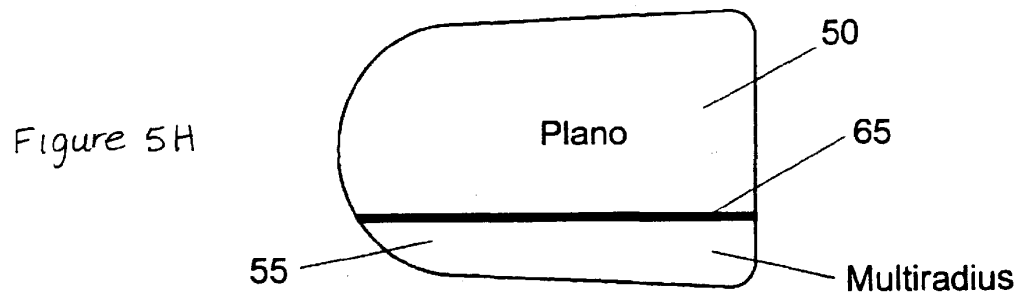
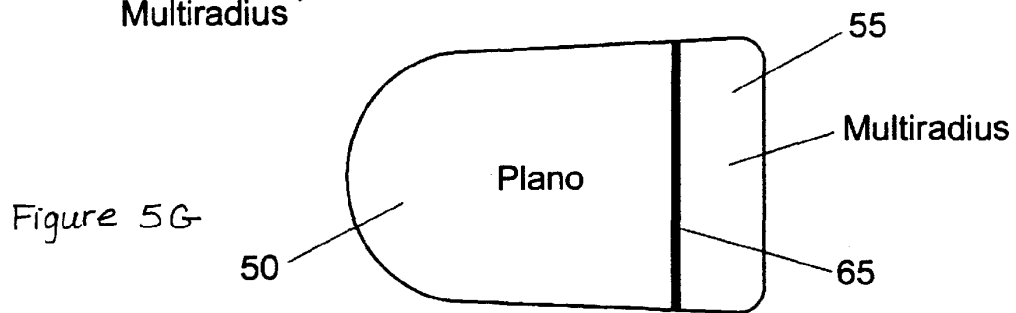
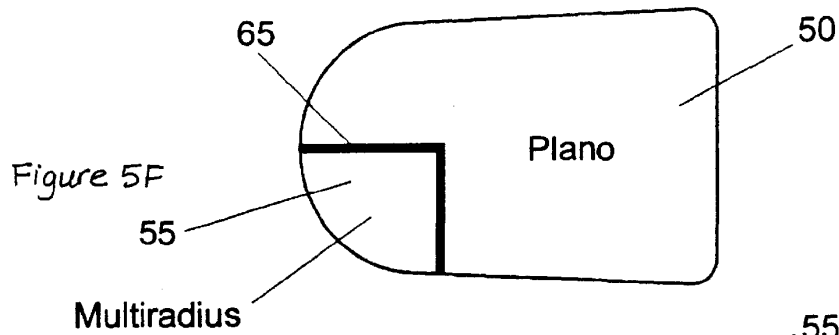
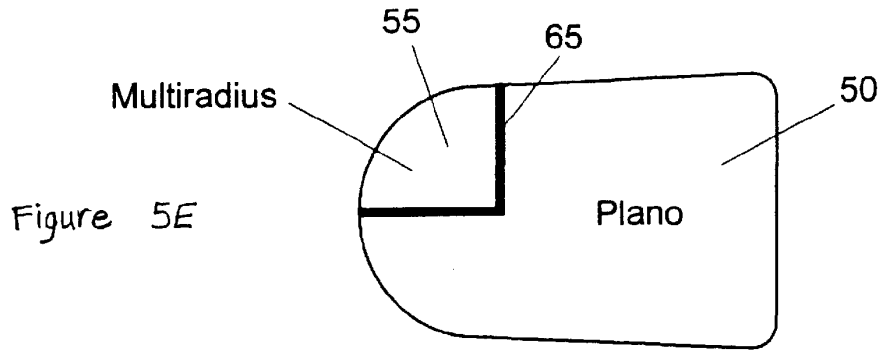

Figure 4





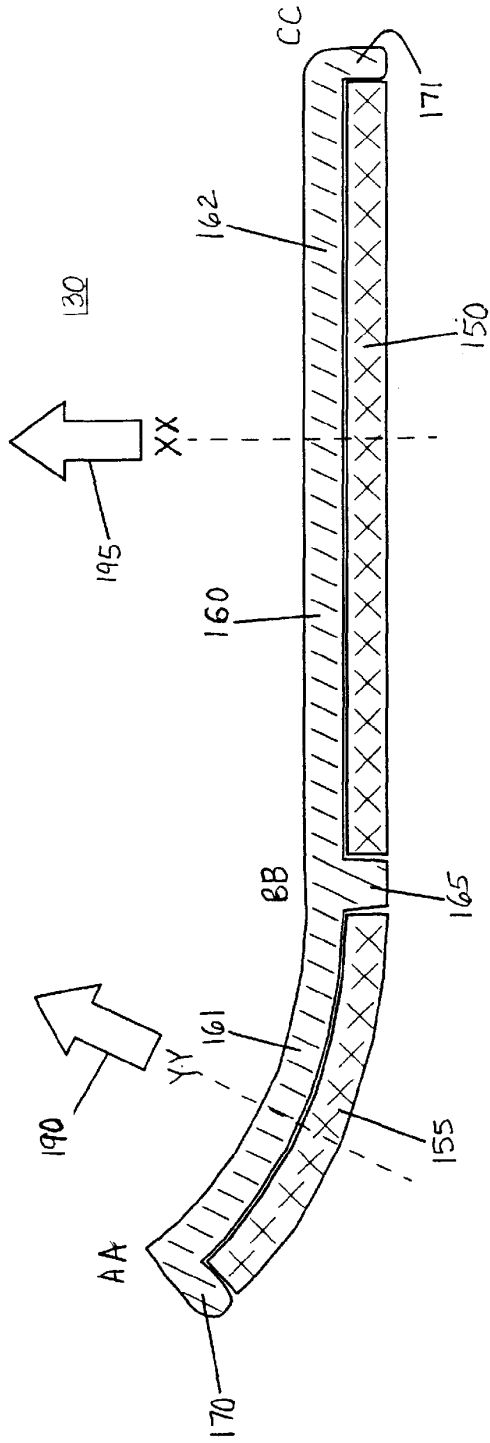

Figure 6

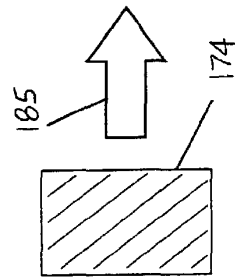

Figure 6A

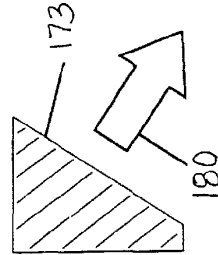

Figure 6B

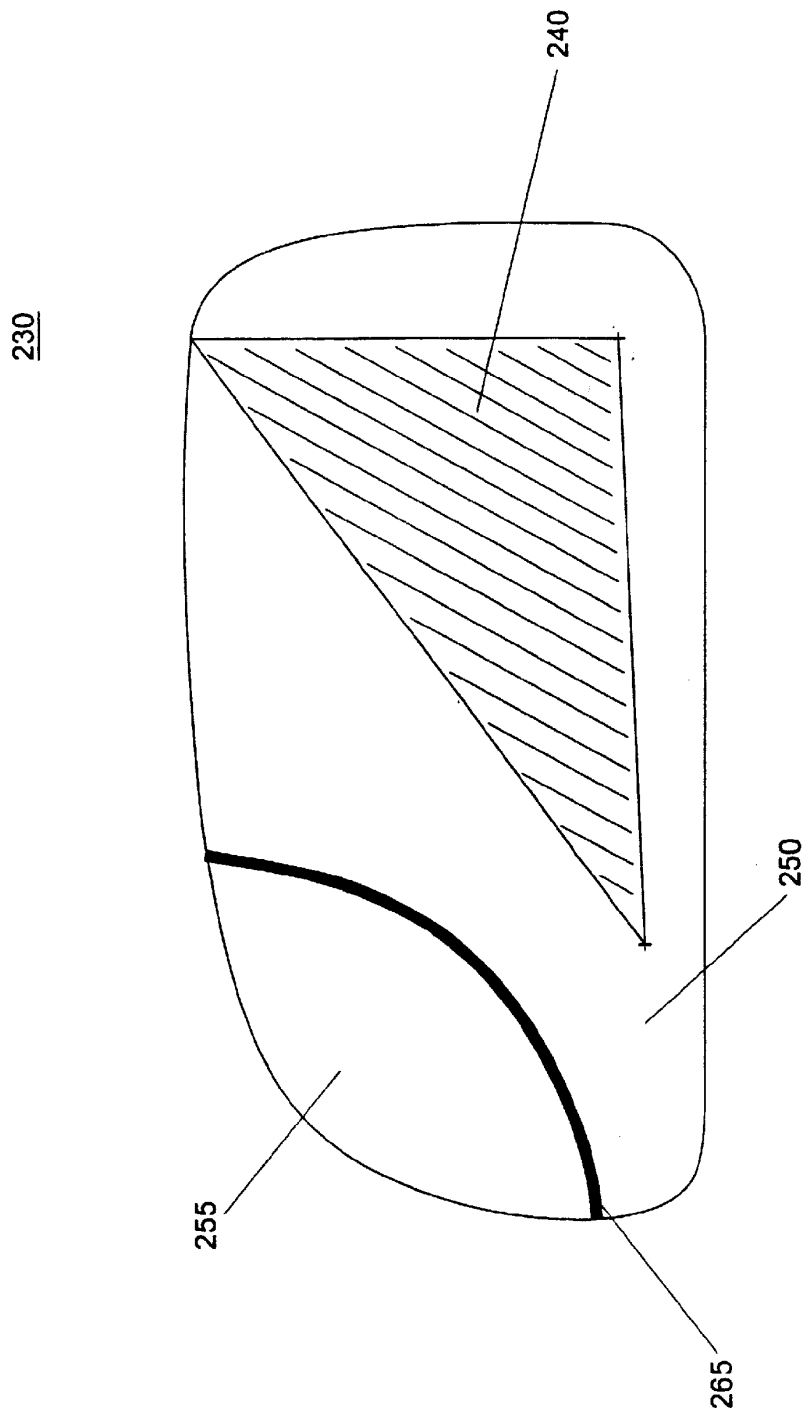

Figure 7

1

EXTERIOR MIRROR PLANO-AUXILIARY REFLECTIVE ELEMENT ASSEMBLY

TECHNICAL FIELD AND BACKGROUND OF THE INVENTION

The present invention relates to exterior sideview mirror assemblies suitable for use on an automobile, and more specifically, to plano-auxiliary reflective element assemblies for use in automobile exterior sideview mirror assemblies.

Automobiles are typically equipped with an interior rearview mirror assembly (adapted for providing a rearward field of view immediately rearward of the vehicle, typically principally in the road lane the vehicle is traveling in) and at least one exterior sideview mirror assembly attached to the side of the vehicle (typically adjacent a front side window portion). The exterior side view mirror assembly typically comprises a reflective element adapted to provide a rearward field of view of the side lane adjacent the vehicle so as to allow the driver see whether a side approaching vehicle is present when the driver is contemplating a lane change. Conventionally, automobiles are equipped with a driver-side exterior mirror assembly and, very often, with a passenger-side exterior sideview mirror assembly mounted to the side of the automobile body opposite to that of the driver-side assembly. While the combination of an interior rearview mirror with a driver-side exterior mirror (and especially in a three-mirror system comprising an interior rearview mirror with a driver-side exterior mirror and a passenger-side exterior mirror) works well in many driving situations, rear vision blind spots present a potential safety hazard while driving. A rear vision blind spot is an area adjacent the side of an automobile where a view of another vehicle (overtaking on that side) is not captured in the rearward field of view of the exterior mirror reflector on that side. This presents a potential safety hazard as the driver, upon checking the view in the exterior sideview mirror and seeing no overtaking vehicle therein, may deem it safe to initiate a lane change, unaware that there is a vehicle immediately adjacent in a blind-spot of the exterior mirror reflector.

Various attempts have been made conventionally to minimize and/or eliminate exterior mirror blind-spots on vehicles. One approach is to make the exterior mirror reflector larger, and particularly wider with respect to the vehicle body. By increasing the width of the exterior mirror reflector, it has a wider field of view rearwards, and hence the reflector blind-spot is reduced. While use of a wide exterior mirror reflector is an option for trucks, buses and commercial vehicles, increasing the width of the reflector used in an exterior sideview mirror assembly mounted on automobiles (such as sedans, station wagons, sports cars, convertibles, minivans, sports utility vehicles, pick-up trucks and similar passenger carrying automobiles) is often not an option. In such domestic automobiles, increasing the width of the exterior mirror reflector increases the size of the exterior sideview mirror assembly with a concomitant increase in aerodynamic drag, increase in fuel consumption, increased difficulty in parking in tight parking spaces, and increased reflector vibration. Use of a non-flat, curved exterior mirror reflector is commonly used to increase rearward field of view without increasing reflector size.

While working well to increase field of view, use of a curved reflector (such as a convex, spherically-curved reflector) has disadvantages. The field of view rearward increases as the degree of curvature of the bent substrate increases (i.e., the field of view rearward increases as the

2

radius of curvature of the bent substrate decreases). However, such wide-angle mirrors have non-unit magnification and distance perception rearward is distorted. For this reason, convex (spherically-bent) exterior mirror reflectors are required in some countries (such as the United States) to carry a safety warning "OBJECTS IN MIRROR ARE CLOSER THAN THEY APPEAR". Distance perception is particularly important for a driver-side exterior mirror. Indeed, Federal Vehicle Safety Standard No. 111 in the United States (the entire disclosure of which is hereby incorporated by reference herein) requires that the driver-side exterior mirror reflector exhibit unit magnification, and places restrictions on the radius of curvature allowed for any bent passenger-side mirror as well as requiring a safety warning be placed thereon. As an improvement over spherically bent/convex mirror reflectors, aspherical or multiradius mirror reflectors (such as are disclosed in U.S. Pat. Nos. 4,449,786 and 5,724,187, the entire disclosures of which are hereby incorporated by reference herein) have been developed. Such mirrors are widely used in Europe and Asia for both driver-side exterior mirror reflectors and for passenger-side exterior mirror reflectors. The aspherical or multiradius mirror reflectors typically have a less curved (larger radius of curvature) reflective region that is inboard or closest to the driver when mounted on a vehicle and, usually separated by a demarcation line or the like, have a more curved (smaller radius of curvature) region that is outboard or farthest from the driver when mounted on a vehicle. However, such aspherical or multiradius reflectors do not have unit magnification and so cannot be used when unit magnification is mandated (such as by FMVSS 111, referenced above).

To supplement a flat driver-side exterior mirror reflector, an auxiliary and separate bent reflector is sometimes incorporated into the driver-side exterior sideview mirror assembly. However, this is often not suitable for passenger automobiles because of the extra space required in the sideview mirror assembly to accommodate an auxiliary reflector element. Also, in most passenger automobiles, the position of the side view mirror reflector is adjustable by the driver (such as by a hand-adjust, or by a manually adjustable cable such as a Bowden cable or by an electrically operable actuator, as known in the art) in order to provide to that driver his or her desired rearward field of view, which ill-suits use of a separate, auxiliary reflector. Likewise, addition of stick-on blind-spot mirror reflectors (such as are commonly sold in automotive parts stores and the like) onto an automobile exterior sideview mirror reflector has disadvantages, including obscuring field of view of the automobile mirror reflector and adding to mirror element vibration.

There is thus a need to provide an automobile exterior sideview reflective element, and particularly a driver-side automobile exterior sideview reflective element, that overcomes the disadvantages above and that provides the driver of the automobile with a distortion-free field of view with unit magnification that is supplemented with a wide-angle view of a side lane blind spot, and there is a need that this be provided in a unitary reflective element assembly module suitable to mount onto, and be adjusted by, the mirror reflector adjustment mechanism (such as an electrically operated, motorized actuator) provided in the exterior sideview mirror assembly.

BRIEF DESCRIPTION OF THE DRAWINGS

FIG. 1 is a perspective view of an automobile equipped with exterior sideview mirror assemblies according to this present invention;

3

FIG. 2 is a top plan partial fragmentary view of the driver's side exterior rearview mirror assembly of FIG. 1;

FIG. 3 is an enlarged sectional view of a plano-multiradius reflective element assembly of the mirror assembly in FIG. 2;

FIG. 4 is an enlarged sectional view of a demarcation element of the plano-multiradius reflective element assembly of FIG. 3;

FIGS. 5A-5H illustrate views of various locations for a plano reflective element and an auxiliary reflective element according to this present invention;

FIG. 6 is a sectional view of a second embodiment of a plano reflective element assembly according to the present invention including a demarcation element formed as a dividing wall in a backing plate element;

FIG. 6A is a cross-section taken along line XX of FIG. 6;

FIG. 6B is a cross-sectional view taken along line YY of FIG. 6; and

FIG. 7 is a schematic of a third embodiment of a plano-auxiliary reflective element assembly according to this present invention.

SUMMARY OF THE INVENTION

This invention provides a plano reflective element with unit magnification and an auxiliary reflector element for use in an exterior sideview mirror assembly on an automobile. More specifically, this invention provides a plano-multiradius reflective element assembly suitable for use in an exterior sideview mirror assembly mounted to the side body of an automobile. The plano-multiradius reflective element assembly of this invention is especially suitable for mounting in a driver-side exterior sideview mirror assembly that is mounted to the side of the automobile body adjacent to the seating position of the driver in the front of the interior vehicular cabin. The plano-multiradius reflective element assembly of this invention comprises a plano portion which has a rearward field of view, when mounted in an exterior sideview mirror assembly mounted to the side body of an automobile, with unit magnification. This plano portion comprises a flat substrate, typically a flat glass substrate, provided with a reflective surface. The plano-multiradius reflective element assembly of this invention also includes a multiradius portion with a rearward field of view, when mounted in an exterior sideview mirror assembly mounted to the side body of an automobile, that has non-unit magnification. The plano portion provides a distortion-free rearward field of view and serves as the principal rearward-viewing portion of the plano-multiradius reflective element. The multiradius portion provides a wide angle rearward field of view, and typically supplements the rearward field of view of the plano portion. This multiradius portion comprises a curved substrate, typically a bent glass substrate, provided with a reflective surface. The plano portion and the multiradius portion are demarcated apart by a demarcation element. The demarcation element enables the driver of a vehicle equipped with the plano-multiradius reflective element of this invention to readily delineate a rearward view in the plano portion from a rearward view in the multiradius portion. The plano portion comprises a flat reflective element and the multiradius portion comprises a bent reflective element. The flat, plano reflective element and the curved, multiradius reflective element are individually and separately manufactured, and are adjacently attached to a single backing plate (which typically comprises a polymeric substrate, most typically a molded polymeric substrate), and with the demarcation element disposed at the joint of the

4

plano, flat reflective element and the multiradius, bent reflective element. The backing plate is fabricated (typically by polymeric molding) to have a flat portion that corresponds to the plano, flat reflective element, and a curved surface that corresponds to the multiradius, curved reflective element. The attachment of the plano reflective element and an auxiliary reflective element to a single backing plate produces a unitary plano-auxiliary reflective element assembly module suitable for mounting in an exterior sideview mirror assembly. By adjusting the position of the backing plate within the exterior sideview mirror assembly, the rearward fields of view of both the plano reflective element and the auxiliary reflective element are simultaneously and similarly aligned.

One embodiment of the invention includes an exterior sideview mirror system suitable for use in an automobile comprising an exterior sideview mirror assembly adapted for attachment to a side of the automobile. The exterior sideview mirror assembly includes a reflective element having a rearward field of view when attached to said side of the automobile. The reflective element is attached to an actuator and is movable by the actuator in order to position the reflective element's rearward field of view in response to a control. The reflective element comprises a plano-multiradius reflective element assembly which comprises a plano reflective element having unit magnification and a separate multiradius reflective element having a multiradius curvature. The plano element and the separate multiradius element of the plano-multiradius reflective element assembly are attached to a backing plate element. The backing plate element is mounted to the actuator such that movement of the backing plate element (and hence the plano-multiradius reflective element assembly) by the actuator simultaneously and similarly moves the plano element and the multiradius element. The plano element and the multiradius element are separately and, preferably, adjacently attached to the backing plate element at a joint.

In a further embodiment, a demarcation element is disposed at this joint to form a demarcation between the plano element and the multiradius element; this demarcation element having a portion visible to a driver of the automobile. Preferably, the demarcation element is dark colored, such as with a color selected from the group consisting of black, grey, blue and brown. Optionally, there is a space at the joint of the plano element and the multiradius element and the demarcation element is at least partially disposed in said space between said plano element and said multiradius element. The demarcation element can comprise at least one of a polymer material, a tape, a plastic film, a paint, a lacquer and a caulk.

In a further embodiment, the demarcation element comprises a wall on the backing plate element; this wall being located on the backing plate element at the joint of the plano element and the multiradius element, this wall separating the respective elements apart.

In preferred embodiments, the portion of the demarcation element visible to a driver of an automobile equipped with the plano-multiradius reflective element assembly of this invention has a width from about 0.5 mm to about 4 mm.

In preferred embodiments, the plano element is attached to the backing plate element by at least one of an adhesive attachment and a mechanical attachment.

In preferred embodiments, the multiradius element is attached to the backing plate element at a location such that, when the exterior mirror assembly is attached to a side of an automobile, at least portion, and preferably at least a sub-

5

stantial portion, of the plano element is disposed closer to the side of the vehicle than any portion of the multiradius element.

In preferred embodiments, the multiradius element comprises a bent glass substrate with radii of curvature in the range of from about 4000 mm to about 50 mm, and the ratio of the width of the plano element to the width of the multiradius element is greater than 1.

In preferred embodiments, the principal axis of the rearward field of view of the auxiliary, multiradius element is different from and angled to the principal axis of the rearward field of view of the plano element when both are attached to the backing plate element of the plano-multiradius reflective element assembly and when the plano-multiradius reflective element assembly is mounted in an exterior sideview mirror assembly on an automobile. The principal axis of the rearward field of view of the plano element is directed generally parallel to the longitudinal axis of an automobile equipped with the plano-multiradius reflective element assembly and the principal axis of the rearward field of view of the multiradius element is directed generally at an angle downwards to the longitudinal axis of the vehicle.

In a preferred embodiment, the exterior sideview mirror assembly equipped with the plano-multiradius reflective element assembly comprises a fixedly attached exterior sideview mirror assembly. In another preferred embodiment, the exterior sideview mirror assembly equipped with the plano-multiradius reflective element assembly comprises a break-away exterior sideview mirror assembly. In another preferred embodiment, the exterior sideview mirror assembly equipped with the plano-multiradius reflective element assembly comprises a powerfold exterior sideview mirror assembly. In another preferred embodiment, the actuator of the exterior sideview mirror assembly to which the plano-multiradius reflective element assembly is mounted comprises an electrically operable actuator. In another preferred embodiment, the actuator of the exterior sideview mirror assembly to which the plano-multiradius reflective element assembly is mounted is controlled by a switch or by a memory controller. In another preferred embodiment, the plano element and/or the multiradius element of the plano-multiradius reflective element assembly comprises an electro-optic reflective element, preferably an electrochromic reflective element. In another preferred embodiment, the plano element of the plano-multiradius reflective element assembly comprises an electro-optic reflective element, preferably an electrochromic reflective element, and the multiradius element comprises a fixed reflectance mirror reflector, such as a fixed reflectance mirror reflector comprises a bent glass substrate coated with a metallic reflector coating.

In a preferred embodiment, the plano-auxiliary reflective element assembly is formed in an integral molding operation.

These and other advantages, features, and modifications will become more apparent when reviewed in conjunction with the drawings and the detailed description which follows.

DETAILED DESCRIPTION OF THE PREFERRED EMBODIMENTS

As illustrated in FIG. 1, passenger automobile 10 (which may be a sedan, a station-wagon, a sports car, a convertible, a minivan, a sports utility vehicle, a pick-up truck or a similar passenger carrying non-commercial, personal trans-

6

portation automobile) includes an interior rearview mirror assembly 18 positioned within interior vehicle cabin 25. Interior vehicle cabin 25 further includes a steering wheel 16, a driver seat 20 positioned at steering wheel 16, a front passenger seat 21 adjacent to driver seat 20 in the front portion of cabin 25, and a rear passenger seat 23 in the rear portion of cabin 25. Automobile 10 further includes a driver-side exterior sideview mirror assembly 12 and a passenger-side exterior sideview mirror assembly 14, each adapted for attachment to opposing sides of automobile body 11, most preferably adjacent to the seating position of the driver seated in driver seat 20 for driver-side assembly 12 and adjacent to the front passenger seat 21 for passenger-side assembly 14. Exterior sideview mirrors, mounted as shown in FIG. 1 close to the driver seating location, are commonly referred to as door-mounted exterior sideview mirror assemblies. Driver-side exterior sideview mirror assembly 12 includes, as illustrated in FIG. 2, a plano-multiradius exterior sideview reflective element assembly 30. Plano-multiradius reflective element assembly 30 is mounted to a reflective element positioning actuator 36. The orientation of plano-multiradius reflective element assembly 30, and hence its rearward field of view, is adjustable by actuator 36 in response to control 37. Control 37 can comprise a handset control that allows the driver manually move the orientation of plano-multiradius reflective element assembly 30 within exterior mirror housing 40 (such as by a lever control or by a cable control) and hence reposition the rearward field of view of plano-multiradius reflective element assembly 30. Alternately, when actuator 36 comprises an electrically actuated actuator that is electrically operable incorporating at least one motor, control 37 can comprise a switch (which, preferably, is operable under control of the driver seated in cabin 25) or control 37 can comprise a memory controller, as known in the automotive mirror art, that controls actuator 36 to move the position of plano-multiradius reflective element assembly 30 to a pre-set orientation that suits the rearward field of view preference of an individual driver. Actuator 36 is mounted to bracket 38 which attaches to vehicle body side 11. Plano-multiradius reflective element assembly 30 is positionable by actuator 36 within exterior mirror housing 40.

Plano-multiradius reflective element assembly 30, as shown in FIG. 3, comprises a plano element 50 and a separate multiradius element 55. Preferably, plano element 50 is adjacent to multiradius element at a joint. At their joint, plano element 50 and separate multiradius element 55 can touch leaving substantially no gap or space therebetween, or plano element 50 and separate multiradius element 55 can be spaced apart at their joint by a space or gap, as in FIG. 3. Plano element 50 and multiradius element 55 are both mounted to surface 59 of, and are both supported by, a single backing plate element 60. Plano element 50 and multiradius element 55 are demarcated apart by demarcation element 65. Surface 61 of backing plate element 60 is preferably adapted to attach, such as by attachment member 64, to actuator 36 when plano-multiradius reflective element assembly 30 is mounted in driver-side exterior sideview mirror assembly 12 (and/or in passenger-side exterior side view mirror assembly 14) such that plano element 50 and multiradius element 55 are adjusted and positioned in tandem and simultaneously when the driver (or alternatively, when a mirror memory system, as is conventional in the rearview mirror arts) activates actuator 36 to reposition the rearward field of view of plano-multiradius reflective element assembly 30. Thus, since elements 50, 55 are part of plano-multiradius reflective element assembly 30, movement of plano-multiradius

reflective element assembly **30** by actuator **36** simultaneously and similarly moves plano element **50** and multiradius element **55**.

Plano element **50** preferably comprises a flat reflector-coated glass substrate having unit magnification, and comprises a reflective surface through which the angular height and width of the image of an object is equal to the angular height and width of the object when viewed at the same distance (except for flaws that do not exceed normal manufacturing tolerances). Plano element **50** may comprise a conventional fixed reflectance mirror reflector or it may comprise a variable reflectance mirror reflector whose reflectivity is electrically adjustable. For example, plano element **50** may comprise a flat glass substrate coated with a metallic reflector coating such as a chromium coating, a titanium coating, a rhodium coating, a metal alloy coating, a nickel-alloy coating, a silver coating, an aluminum coating (or any alloy or combination of these metal reflectors). The metal reflector coating of plano element **50** may be a first surface coating (such as on surface **66**) or a second surface coating (such as on surface **67**), as such terms are known in the mirror art. The reflector coating on plano element **50** may also comprise a dielectric coating, or a multilayer of dielectric coatings, or a combination of a metal layer and a dielectric layer to form automotive mirror reflectors as known in the automotive mirror art. If a variable reflectance reflector element, plano element **50** preferably comprises an electro-optic reflector element and, most preferably, an electrochromic reflector element.

When mounted into exterior side view mirror assembly **12** and/or **14**, plano-multiradius reflective element assembly **30** is preferably orientated so that at least a portion of (more preferably a substantial portion of) the reflector surface of plano element **50** is positioned closer to the vehicle body (and hence to the driver) than any portion of the reflector surface of multiradius element **55**. Thus, and referring to FIG. 3, side A of plano element **50** of plano-multiradius reflective element assembly **30** is positioned closer to the driver than side D of multiradius element **55** when plano-multiradius reflective element assembly **30** is mounted on an automobile. Also, when mounted into exterior side view mirror assembly **12** and/or **14**, surfaces **66**, **68** of plano-multiradius reflective element assembly **30** face rearwardly in terms of the direction of vehicle travel.

Multiradius element **55** of plano-multiradius reflective element assembly **30** preferably comprises a curved/bent mirrored glass substrate. The degree of curvature preferably increases (and hence the local radius of curvature decreases) across the surface of multiradius element **55** with the least curvature (largest radius of curvature) occurring at the side of multiradius element **55** (side C in FIG. 3) positioned adjacent its joint to plano element **50** when both are mounted on backing plate element **60**. Thus, and referring to FIG. 3, the local radius of curvature at side C of multiradius element **55**, when mounted on backing plate element **60**, is larger than at side D. Also, the local radius of curvature preferably progressively decreases across multiradius element **55** from side C to side D. Preferably, the local radius of curvature at side C of multiradius element **55** is at least about 1000 mm; more preferably is at least about 2000 mm and most preferably is at least about 3000 mm whereas the local radius of curvature at side D of multiradius element **55** is, preferably, less than about 750 mm, more preferably less than about 350 mm; most preferably less than about 150 mm. Preferably, multiradius element **55** comprises a bent glass substrate with radii of curvature in the range of from about 4000 mm to about 50 mm. The multiradius prescription for the multira-

dius element to be used in a particular exterior mirror assembly can vary according to the specific field of view needs on a specific automobile model.

The total field of view rearwardly of the automobile of the plano-auxiliary reflective element assembly (which is a combination of the field of view of the plano reflective element and of the auxiliary reflective element) preferably generally subtends an angle of at least about 20 degrees (and more preferably, generally subtends an angle of at least about 25 degrees and most preferably, generally subtends an angle of at least about 30 degrees) with respect to the side of an automobile to which is attached an exterior sideview mirror assembly equipped with the plano-auxiliary reflective element assembly.

Multiradius element **55** may comprise a conventional fixed reflectance mirror reflector or it may comprise a variable reflectance mirror reflector whose reflectivity is electrically adjustable. For example, multiradius element **55** may comprise a flat glass substrate coated with a metallic reflector coating such as a chromium coating, a titanium coating, a rhodium coating, a metal alloy coating, a nickel-alloy coating, a silver coating, an aluminum coating (or any alloy or combination of these metal reflectors). The metal reflector coating of multiradius element **55** may be a first surface coating (such as on surface **68**) or a second surface coating (such as on surface **69**), as such terms are known in the mirror art. The reflector coating on multiradius element **55** may also comprise a dielectric coating, or a multilayer of dielectric coatings, or a combination of a metal layer and a dielectric layer to form automotive mirror reflectors as known in the automotive mirror art. If a variable reflectance reflector element, multiradius element **55** preferably comprises an electro-optic reflector element and, most preferably, an electrochromic reflector element.

Also, it is preferable that the thickness of plano element **50** and multiradius element **55** be substantially the same in dimension so that their respective outer surfaces, **66** and **68**, are substantially coplanar so that a driver can readily view images in either or both elements. The thickness dimension of elements **50,55** is determined by the thickness of the substrate (or in the case of laminate-type electrochromic reflective elements, the thickness of the two substrates between which the electrochromic medium is disposed). For example, plano element **50** and/or multiradius element **55** can comprise a reflector coated glass substrate or panel of thickness preferably equal to or less than about 2.3 mm, more preferably equal to or less than about 1.6 mm, most preferably equal to or less than about 1.1 mm. Use of a thinner substrate is beneficial in terms of improving the overall stability/vibration performance of the image seen in plano-multiradius reflective element assembly **30** when mounted to an automobile.

The reflector area of plano element **50** is preferably larger than that of multiradius element **55**. Preferably, the width dimension of plano element **50** is larger than the width dimension of multiradius element **55** (both width dimensions measured at their respective widest dimension and with the width of the respective element being gauged with the respective element oriented as it would be orientated when mounted on the automobile). Thus, and referring to FIG. 3, the distance from side A to side B of plano element **50** is larger than the distance from side C to side D of multiradius element **55**. Thus, the ratio of the width of plano element **50** to the width of multiradius element **55** is preferably greater than 1; more preferably greater than 1.5; most preferably greater than 2.5 in order to provide a large, unit magnification plano element **50** as the principal rear

viewing portion of plano-multiradius reflective element assembly **30** and providing multiradius element **55** as a smaller, auxiliary, separate, wide-angle viewing portion of plano-multiradius reflective element assembly **30**. For plano-multiradius reflective element assemblies to be mounted to the exterior sideview assemblies of passenger automobiles used non-commercially and for non-towing purpose, the width of plano element **50** (at its widest dimension) is preferably in the range of from about 50 mm to about 225 mm; more preferably in the range of from about 75 mm to about 175 mm; most preferably in the range of from about 100 mm to about 150 mm.

Backing plate element **60** is preferably a rigid polymeric substrate capable of supporting plano element **50** and multiradius element **55**. Backing plate element **60** comprises a flat portion (generally between E and F as shown in FIG. 3) that corresponds to and is aligned with plano element **50**. Backing plate element **60** also comprises a curved portion (generally between G and H as shown in FIG. 3) that corresponds to and is aligned with multiradius element **55**. Preferably, curved portion G-H of multiradius element **55** is fabricated with a multiradius prescription that is substantially the same as the multiradius prescription of multiradius element **55**. Backing plate element **60** is formed as a single element to which elements **50** and **55** are separately attached. Preferably, backing plate element **60** is formed by injection molding of a thermoplastic or a thermosetting polymer resin. Materials suitable to use for backing plate element **60** include unfilled or filled polymeric materials such as glass and/or mineral filled nylon or glass and/or mineral filled polypropylene, ABS, polyurethane and similar polymeric materials. For example, backing plate element **60** can be formed of ABS in an injection molding operation. Plano element **50** can be cut from a stock lite of flat chromium mirror-coated 1.6 mm thick glass. Multiradius element **55** can be cut from a stock lite of multiradiusly-bent chromium mirror-coated 1.6 mm thick glass. Plano element **50** and multiradius element **55** can then be attached (such as by an adhesive attachment such as an adhesive pad or by mechanical attachment such by clips, fasteners or the like) to the already molded backing plate element **60**. Alternatively, plano element **50** and multiradius element **55** can each be individually loaded into an injection molding tool. Once loaded, a polymeric resin (or the monomers to form a polymeric resin) can be injected into the mold in order to integrally form backing plate element **60** with elements **50**, **55** integrally molded thereto. Integral molding of the backing plate element to plano element **50** and multiradius element **55** (along with any other elements such as the demarcation element **65**) in a single integral molding operation, is a preferred fabrication process for plano-multiradius reflective element assembly **30**.

Plano-multiradius reflective element assembly **30** further preferably includes demarcation element **65** that functions to delineate and demarcate the plano region of the assembly from the wide-angle, multiradius region and also preferably functions to prevent ingress of debris, dirt, water and similar contaminants (such as road splash, car wash spray, rain, snow, ice, leaves, bugs and similar items that plano-multiradius reflective element assembly **30** would be subject to when mounted and used on an automobile) into any gap between plano element **50** and multiradius element **55** when both are attached to backing plate element **60**. Optionally, at least a portion of demarcation element **65** can be disposed in any gap between plano element **50** and multiradius element **55** at their joint on backing plate element **60**. Preferably, demarcation element **65** is formed of a polymeric material

that is dark colored (such as black or dark blue or dark brown or dark grey or a similar dark color) such as a dark colored polypropylene resin or a dark colored nylon resin or a dark colored polyurethane resin or a dark colored polyvinyl chloride resin or a dark colored silicone material. Most preferably demarcation element **65** is formed of an at least partially elastomeric material (such as silicone, or EPDM, or plasticized PVC or the like) in order to provide a degree of vibration dampening for elements **50**, **55**. As shown in FIG. 4, demarcation element **65** optionally includes a crown portion **70** that includes wing portions **73**, **73'** and a stem portion **71**. Stem portion **71** preferably has a cross-sectional width CCC of less than about 4 mm, more preferably less than about 3 mm and, most preferably less than about 2 mm. Crown portion **70** preferably is dimensioned to not protrude substantially beyond surfaces **66**, **68** of elements **50**, **55** when demarcation element **65** is installed between elements **50** and **55**. Also, wings **73**, **73'** are preferably dimensioned to protrude (most preferably slightly) onto surfaces **66**, **68** of elements **50**, **55** when demarcation element **65** is installed between elements **50** and **55** in order to provide a weather barrier seal and/or to at least partially accommodate any dimensional tolerances of elements **50**, **55** that could lead to variation in the inter-element gap between sides C and B. While the demarcation element shown in FIG. 4 is one embodiment, other constructions are possible including a demarcation element that has minimal or no crown portion. Likewise, a demarcation element can have little or no stem portion, especially when the joint between plano element **50** and multiradius element **55** includes no gap to receive a stem. Also, where a gap at the plano to multiradius joint exists, any stem of the demarcation element can at least partially be disposed in such gap so as to at least partially fill the gap (or it can optionally substantially fill the gap). Optionally, demarcation element **65** is fabricated by injection molding of a polymeric resin. After plano element **50** and multiradius element **55** have been attached to backing plate element **60**, a separately formed demarcation element **65** can then be inserted (and secured such as by an adhesive or by a mechanical attachment such as by a fastener) into a space between elements **50** and **55**. Note that, optionally, side B of plano element **50** and side C of multiradius element **55** can touch (leaving substantially no gap or space therebetween). In such a situation, demarcation element **65** can comprise a dark colored strip such as of a tape or of a plastic film that covers the joint between elements **50** and **55**. Alternatively, demarcation element **65** can comprise a preferably dark-colored paint, lacquer, caulk or similar material that can be applied to, and that can preferably fill into, the joint between elements **50** and **55**. The width of the portion of demarcation element **65** that is visible to the driver is preferably less than about 4 mm, more preferably less than about 3 mm and most preferably less than about 2 mm, but is equal to or greater than about 0.5 mm, more preferably is equal to or greater than about 0.75 mm, most preferably is equal to or greater than about 1 mm in order to provide adequate demarcation of the plano region from the multiradius radius region without unduly obscuring the rearward field of view of the respective elements. Optionally, demarcation element **65** can be formed as part of backing plate element **60** such as by forming demarcation element **65** as a wall structure of the backing plate element that partitions backing plate element **60** into two regions: A first region adapted to receive plano reflective element **50** and a separate and adjacent second region adapted to receive multiradius reflective element **55**.

Thus, and referring to FIG. 6, a second embodiment of plano-multiradius reflective element assembly **130** may

11

include a backing plate element **160** which comprises a plate molded from a polymer resin (such as a polyolefin such as polypropylene or such as ABS or nylon) with a demarcation element **165** that is molded as a wall structure that partitions backing plate element **165** into a first region (from CC to BB) adapted to receive and accommodate plano reflective element **150** and into a second region (from BB to AA) adapted to receive and accommodate wide-angle optic multiradius reflective element **155**. Note that section AA to BB of backing plate element **160** is angled to section BB to CC. Such angling of the auxiliary reflective element relative to the plano element can be advantageous in allowing the auxiliary reflective element view a portion of the road adjacent the automobile that is in a blind spot of the plano reflective element. In this regard, it is preferable that the multiradius element be angled away from the plane of the plano element, as shown in FIG. 6 by the angling of section AA to BB to section BB to CC.

Preferably, demarcation element **65** is formed in an integral molding operation, along with formation of backing plate element **60**, and attachment of elements **50**, **55** thereto. For example, plano element **50** and multiradius element **55** can each be individually loaded into an injection molding tool. Once loaded, a polymeric resin (or the monomers to form a polymeric resin) can be injected into the mold in order to integrally form backing plate element **60** with elements **50**, **55** integrally molded thereto and, in the same molding operation and in the same tool, also form by molding the demarcation element. Integral molding of the backing plate element to plano element **50** and multiradius element **55** along with creation in the single molding operation of demarcation element **65** (along with any other elements such as attachment member **64**) in a single integral molding operation, is a preferred fabrication process for plano-multiradius reflective element assembly **30**. By loading all the sub components of plano-multiradius reflective element assembly **30** into a molding tool, and then injecting polymeric resin to form the backing plate, demarcation member and any attachment member, a substantially complete or fully complete plano-multiradius reflective element assembly can be unloaded from the tool at the completion of the integral molding operation (as known in the molding art), thus enabling economy in manufacturing and accommodation of any dimensional tolerances in the sub components. Where integral molding is so used, it is preferable to use a reactive molding operation such as reactive injection molding of a urethane as such reactive injection molding operations occur at relatively modest temperatures.

Plano element **50** and/or multiradius element **55** can comprise a heater element, as known in the automotive mirror art, that is operable to deice/demist surfaces **66**, **68**. Such heater elements are conventional and can comprise a positive temperature coefficient heater pad, a resistive heater element and/or a conductive coating. Plano element **50** and/or multiradius element **55** can also optionally comprise a scatterproofing member, as known in the automotive mirror art, such as an adhesive tape, to enhance safety in an accident.

Also, plano element **50** and/or multiradius element **55** can comprise a variable reflectance electro-optic element such as an electrochromic mirror reflector. Thus, both element **50** and element **55** can comprise an electrochromic mirror element or either of element **50** and element **55** can comprise an electrochromic mirror element and the other can comprise a fixed reflectance non-variable reflectance mirror element such as a metal reflector coated glass panel such as a chromium coated glass substrate. Also, if both plano

12

element **50** and multiradius element **55** comprise an electro-optic element such as an electrochromic mirror element capable of electrically dimmable reflectivity, both elements **50**, **55** can dim together and in tandem under control of a common dimming control signal (typically provided by an electro-optic automatic dimming interior mirror assembly mounted in the cabin of the automobile and equipped with photosensors to detect incident glare and ambient light). Alternately, if both plano element **50** and multiradius element **55** comprise an electro-optic element such as an electrochromic mirror element capable of electrically dimmable reflectivity, element **50** can dim independently of element **55** (such as is disclosed in U.S. Pat. No. 5,550,677, the entire disclosure of which is hereby incorporated by reference herein). If either or both of elements **50**, **55** comprise an electrochromic element, preferably, the electrochromic reflective element comprises a front substrate and a rear substrate with an electrochromic medium disposed between, such as a solid polymer matrix electrochromic medium such as is disclosed in U.S. patent application Ser. No. 09/350,930, filed Jul. 12, 1999, entitled "ELECTROCHROMIC POLYMERIC SOLID FILMS, MANUFACTURING ELECTROCHROMIC DEVICES USING SUCH FILMS, AND PROCESSES FOR MAKING SUCH SOLID FILMS AND DEVICES" to Desaraju V. Varaprasad et al., now U.S. Pat. No. 6,154,306, or such as is disclosed in U.S. Pat. Nos. 5,668,663; 5,724,187; 5,910,854; and 5,239,405, the entire disclosures of which are hereby incorporated by reference herein. Most preferably, in such laminate-type electrochromic mirror reflective elements, the front substrate comprises a glass plate of thickness less than about 1.6 mm, most preferably about 1.1 mm thickness or lower, and the rear substrate comprises a glass plate of thickness equal to or greater than about 1.6 mm, more preferably greater than about 1.8 mm thickness, most preferably equal to or greater than about 2.0 mm thickness. The rearmost surface of the rear substrate (the fourth surface as known in the mirror art) is reflector coated with a high reflecting metal film such as of aluminum or silver, or an alloy of aluminum or silver. Most preferably, the front-most surface of the rear substrate (the third surface as known in the mirror art) is reflector coated with a high reflecting metal film such as of aluminum or silver, or an alloy of aluminum or silver.

Backing plate element **65** of plano-multiradius reflective element assembly **30** is optionally equipped on its rearmost surface with attachment member **64** to facilitate attachment to the reflector-positioning actuator of the exterior sideview mirror assembly that plano-multiradius reflective element assembly **30** is mounted to. Attachment of plano-multiradius reflective element assembly **30** to the actuator can be by mechanical attachment such as by a tab, clip or fastener, or may be by adhesive attachment such as by a silicone adhesive, a urethane adhesive or a similar adhesive material such as a tape coated on both surfaces with a pressure sensitive adhesive to form a "double-sticky" tape. Exterior sideview mirror assembly **12** and/or **14**, on whose mirror reflector-positioning actuator the plano-multiradius reflective element assembly is mounted, can be a fixedly attached exterior sideview mirror assembly, a break-away exterior sideview mirror assembly and a powerfold exterior sideview mirror assembly, as known in the automotive mirror art.

FIGS. 5A–5H shows various arrangements of multiradius reflective element **55** relative to its adjacent plano reflective element **50** (with demarcation element **65** disposed at their joint). In FIGS. 5A, 5B, 5C, 5E and 5F, plano element **50** is mounted wholly inboard of multiradius element **55**. Thus, in

13

FIGS. 5A, 5B, 5C, 5E and 5F, plano element 50 would be disposed closer to the vehicle body (and hence to the driver) than multiradius element 55 when plano-multiradius reflective element assembly 30 was mounted in an exterior sideview mirror attached to a side of an automobile. Therefore, in FIGS. 5A, 5B, 5C, 5E and 5F, plano element 50 would be mounted inboard relative to the side of the automobile and multiradius element 55 would be mounted outboard relative to the side of the automobile. In general, the location of the multiradius reflective element in the outboard, upper portion of the plano-multiradius reflective element assembly, as in FIGS. 5B and 5E, is preferred as this allows the plano portion provide a desired rearward field of view along the side of the vehicle. The configuration as shown in FIG. 5G (where the multiradius reflective element is along the inboard side of the assembly) is also desirable as this allows the driver view the side of the vehicle (something many drivers desire in order to have a frame of reference for their rearward field of view) while facilitating having a wide field of view for the plano portion.

Unlike trucks, busses and commercial vehicles the size of an exterior sideview mirror assembly suitable for use on an automobile (and especially when the automobile is not towing a trailer or the like) is restricted. Automobiles generally are non-commercial vehicles intended for personal transportation. Automobiles typically carry 5 passengers or less, although minivans and large sports utility vehicles (which are classified herein as automobiles) can have seat accommodation for up to 10 passengers (although accommodation for 7 passengers or less is more common). The tandem mounting of a plano element of unit magnification and a separate auxiliary element onto a common, single backing plate element, and the mounting of this backing plate element onto an actuator of an exterior sideview mirror assembly so that a driver can simultaneously and similarly move the auxiliary element and the plano element so as to position their respective rearward fields of view, and to achieve this within the relatively restricted space available in a standard automobile-sized exterior sideview mirror assembly is an important element of this present invention. By utilizing a plano element of unit magnification in the plano-multiradius reflective element assembly, and by sizing the reflector area of the plano element larger than the reflector area of the multiradius element and, preferably, by sizing the reflector area of the plano element at a sufficiently large size that the rearward field of view provided by the plano element alone meets and satisfies the minimum field of view requirement mandated by an automaker specification and/or a government regulation, the need to provide a safety warning indicia such as "OBJECTS IN MIRROR ARE CLOSER THAN THEY APPEAR" in the plano element and/or in the multiradius element can be obviated. Preferably, the plano element comprises a reflector surface area of a size sufficient, when mounted as part of a plano-multiradius reflective element assembly in a driver-side exterior sideview mirror assembly on an automobile, to provide the driver of the automobile a view of a level road surface extending to the horizon from a line, perpendicular to a longitudinal plane tangent to the driver's side of the automobile at the widest point, extending 8 feet out from the tangent plane 35 feet behind the driver's eyes (at a nominal location appropriate for any 95th percentile male driver or at the driver's eye reference points established in Federal Motor Vehicle Standard No. 104), with the driver seated in the driver's seat and with the driver's seat in the rearmost position. Also, preferably, the aspect ratio of the plano-multiradius reflective element assembly (defined as the ratio

14

of its largest vertical dimension to its largest horizontal dimension, measured with the plano-multiradius reflective element assembly oriented as it would be oriented when mounted in an exterior sideview mirror assembly on an automobile, and with "horizontal" being generally parallel with the road surface the automobile travels on and "vertical" being generally perpendicular to the road surface the automobile travels on) is preferably less than 1, more preferably less than 0.8, most preferably less than 0.6. Further, it is preferable that the multiradius element be disposed outboard (relative to the side of the vehicle and with the plano-multiradius reflective element assembly oriented as it would be when mounted in an exterior sideview mirror assembly on an automobile) on the plano-multiradius reflective element assembly so that the multiradius element is positioned to provide an auxiliary, wide-angle view of a "blind-spot" region in an adjacent sidlane while the more inboard-disposed plano element with unit magnification provides the principal sideview image to the driver.

Also, it is preferable that the principal axis of the rearward field of view of the multiradius element be different from and angled to the principal axis of the rearward field of view of the plano element when both are attached to the backing plate element of the plano-multiradius reflective element assembly and when the plano-multiradius reflective element assembly is mounted and operated in an exterior sideview mirror assembly on an automobile. Preferably, the principal axis of the rearward field of view of the plano element is directed generally parallel to the road that the automobile equipped with the plano-multiradius reflective element assembly is travelling on (i.e. generally parallel to the longitudinal axis of the automobile) so as to provide the driver with a long-distance view of approaching vehicles in the side lane that the plano element views). However, preferably the principal axis of the rearward field of view of the multiradius element of, for example, a door-mounted driver-side (or passenger-side) exterior sideview mirror assembly in which the plano-multiradius reflective element assembly is mounted is directed generally downwardly towards the road surface adjacent to the driver seating location and/or several feet (such as about 1 foot to about 24 feet; more preferably, about 1 foot to about 12 feet; most preferably about 1 foot to about 8 feet in distance) to its rear (in order to capture a field of view of a rear approaching vehicle that is approaching to overtake, or is about to overtake, or is overtaking the automobile equipped with the plano-multiradius reflective element assembly). Thus, preferably, the principal axis of the rearward field of view of the multiradius element is angled and directed generally downwardly with respect to the longitudinal axis of the automobile and thus is at an angle to the principal axis of the rearward field of view of the plano element. For example, multiradius element 155 when attached to surface 173 of backing plate 160 (see FIG. 6B) would have its principal axis of rearward view as indicated by 180 as in FIG. 6B, and as such would be canted towards the road surface when mounted in an exterior sideview mirror assembly attached to the side of an automobile. By contrast, plano element 150 when attached to surface 174 of backing plate 160 (see FIG. 6A) would have a principal axis as indicated by 185 as in FIG. 6A and, as such, would be generally parallel to the road surface when mounted in an exterior sideview mirror assembly attached to the side of an automobile. Having the multiradius element canted somewhat downwards towards the road surface assists visual detection by the driver of overtaking vehicles in the traditional "blind-spot" in the adjacent side lane. The angle that the multiradius element is

15

angled on the backing plate element of the plano-multiradius reflective element assembly relative to the plane of the plano reflective element will vary from automobile model to model, but generally is preferred to be in the about 1 degree to about 10 degree range; about 2 degree to about 8 degree range more preferred; and about 3 degree to about 6 degree range most preferred. In order to conveniently achieve an angling of the multiradius portion with respect to the plano portion (and preferably a downward angling), the portion of the backing plate element that the multiradius reflective element is attached to can be angled relative to the adjacent portion of the backing plate element that the plano reflective element is attached to. Thus, and referring to FIG. 6, plano-multiradius reflective element assembly 130 includes a molded polymeric backing plate element 160 comprising a generally flat portion 162 (between BB and CC in FIG. 6) and an adjacent curved portion 161 (between AA and BB). As indicated by 190 and 195, portion AA to BB of backing plate element 160 is generally angled to portion BB to CC of backing plate 160. Preferably, the portion of backing plate element 160 to which the auxiliary reflective element attaches is angled towards the front (compared to the angling of plano reflective element) of an automobile equipped with the plano-auxiliary reflective element assembly of the present invention. FIG. 6 is a view of plano-multiradius reflective element assembly 130 as it would appear from above the vehicle as it would be orientated in use (with portion 162 closer to the driver than portion 161). The wall section, section XX in FIG. 6, taken through section 162 of backing plate element 160 is of substantially constant dimension (as illustrated in FIG. 6A) whereas the wall section, section YY in FIG. 6B, taken through section 161 of backing plate element 160 is of varying dimension and is angled. Plano reflective element 150 and multiradius reflective element 155 (for example, plano element 150 can comprise an electrochromic mirror element and multiradius element 155 can comprise a chrome coated glass reflector) are attached to portions 162 and 161, respectively. By being supported on the angled face 173 (see FIG. 6B) of portion 161, the principal viewing axis of multiradius reflector element 155 is angled downwards towards the road surface, as compared to the more horizontal-viewing principal viewing axis of plano element 150, when plano-multiradius reflective element 130 is mounted in an exterior sideview mirror assembly on an automobile. Demarcation element 165 is preferably molded in the same molding tool as is used to mold backing plate element 160, and so demarcation element 165 is formed as an integral part of backing plate element 160, forming a wall thereof that partitions the surface of backing plate element 160 into a region for receiving the plano reflective element 150 and a region for receiving the auxiliary reflective element 155. Also, end-caps 170 and 171 are optionally provided. Plano reflective element 150 can attach into the cavity formed between demarcation element 165 and end-cap 171; multiradius reflective element 155 can attach into the cavity formed between demarcation element 165 and end-cap 170. Note that the portion of the backing plate element where the wide-angle optic multiradius element attaches can have a thicker wall thickness than that of the portion of the backing plate element where the unit magnification optic element attaches in order to allow for the angling of the multiradius element downwardly relative to the angle of the plano element, as illustrated in FIGS. 6A–B. As illustrated in FIGS. 6A–B, the angle downwards to the longitudinal axis of the vehicle of the multiradius element can generally be set by an angling of a surface of the backing plate element in

16

order to ensure that the principal axis of the rearward field of view of the plano element is directed generally parallel to the longitudinal axis of an automobile equipped with the plano-multiradius reflective element assembly and that the principal axis of the rearward field of view of the multiradius element is directed generally at an angle downwards to the longitudinal axis of the automobile.

Note that the provision of the plano-multiradius reflective element assembly of this invention as a unitary module has manufacturing advantages, particularly for exterior sideview mirror assembly manufacturers who can procure a plano-multiradius reflective element assembly module from a mirror reflector supplier and then mount the plano-multiradius reflective element assembly module onto an actuator.

Referring to FIG. 7, a third embodiment 230 of a plano-multiradius reflective element assembly is illustrated. Plano-multiradius reflective element assembly 230 includes a plano reflective element 250 and a separate multiradius reflective element assembly 255, both individually attached to a backing plate element, and with demarcation element 265 disposed at their joint. Plano-multiradius reflective element assembly 230 is about 8.5 inches wide and about 4.25 inches tall (aspect ratio of 0.5), at their largest dimension. Shown as the shaded triangle 240 in plano reflective element 250 is the image of a triangular target object set about 35 feet rearward and of width about 8 feet and of height of about 4.1 feet as would be seen were plano-multiradius reflective element assembly 230 mounted in a driver-side exterior sideview mirror assembly in an automobile such as a sports utility vehicle. In general, it is desirable that the plano reflective element be dimensioned and configured so as to have its rearward field of view capture an image (that is visible, by reflection in the plano reflective element, to a driver seated in the driver's seat in an automobile to which is attached an exterior sideview mirror assembly equipped with the plano-auxiliary reflective element assembly according to this present invention) of a triangular shaped target located about 35 feet rearward of the driver seating location, extending about 8 feet out from the plane defined by the side of the automobile and reaching a height of between about 4 feet and about 5 feet from the road surface at that location 35 feet rearward of the automobile. The total field of view rearwardly of the vehicle of plano-multiradius reflective element assembly 230 (which is a combination of the field of view of plano reflective element 250 and of the auxiliary multiradius reflective element 255) preferably generally subtends an angle of at least about 30 degrees (and more preferably, generally subtends an angle of at least about 35 degrees and most preferably, generally subtends an angle of at least about 40 degrees) with respect to the side of an automobile to which is attached an exterior sideview mirror assembly equipped with plano-multiradius reflective element assembly 230.

Also, although it is preferable to utilize a multiradius or compound curvature reflective element such as an aspherical element or a compound curvature element for the auxiliary mirror element adjacent the plano reflective element (as this enables least discontinuity in image at the joint between the adjacent elements of the assembly), a spherical reflective element (that has substantially only one radius of curvature and, as such, is a section from a sphere) can optionally be used adjacent the plano reflective element instead of, or in addition to, the multiradius reflective element. Also, a plano auxiliary mirror such as a flat mirrored substrate can be used, less preferably, as a substitute for a multiradius reflective element in those embodiments where the auxiliary reflective

17

element is angled relative to the plane of the principal, plano reflective element so as to view a blind spot region of the principal plano element. Also, the plano-multiradius reflective element assembly can optionally be fixedly attached to an exterior sideview mirror assembly housing that is not 5 movable, or, alternately, the exterior sideview mirror assembly housing to which the plano-multiradius reflective element assembly is fixedly attached can itself be actuated to move, such as by motor action, so that by moving the exterior sideview mirror assembly housing, the field of 10 rearward view of the plano-multiradius reflective element assembly fixedly attached thereto can correspondingly move and be repositioned to suit the field of view need of a particular driver seated in the automobile cabin.

The above description is considered that of the preferred 15 embodiments only. Modification of the invention will occur to those skilled in the art and to those who make or use the invention. Therefore, it is understood that the embodiments shown in the drawings and described above are merely for illustrative purposes and are not intended to limit the scope of the invention, which is defined in the following claims as 20 interpreted according to the principles of patent law, including the doctrine of equivalents.

I claim:

1. An exterior sideview mirror system suitable for use on an automobile, said exterior sideview mirror system comprising:

an exterior sideview mirror assembly adapted for attachment to a side of an automobile;

said exterior sideview mirror assembly including a reflective element having a rearward field of view when attached to the side of the automobile;

said reflective element attached to an electrically-operated actuator and movable by said actuator in order to position said rearward field of view in response to a control;

wherein said reflective element comprises a plano-multiradius reflective element assembly, said plano-multiradius reflective element assembly comprising a 40 plano reflective element having unit magnification and a separate multiradius reflective element having a multiradius curvature, said plano reflective element having a rearward field of view with a principal axis;

said plano reflective element and said multiradius reflective 45 element of said plano-multiradius reflective element assembly mounted adjacently in said plano-multiradius reflective element assembly in a side-by-side relationship and not superimposed with one reflective element on top of the other reflective element, and supported by a backing plate element, said backing plate element mounting to said actuator such that movement of said backing plate element of said plano-multiradius reflective element assembly by said actuator simultaneously and similarly moves said plano 50 reflective element and said multiradius reflective element, said multiradius reflective element having a rearward field of view with a principal axis, said backing plate element have a first support portion supporting said plano-reflective element and a second support portion supporting said multiradius reflective element, said second support portion tilted forward with respect to said first support portion whereby said principal axis of said rearward field of view of said multiradius reflective element is angled downwardly 65 and outwardly with respect to said principal axis of said rearward field of view of said plano reflective element

18

when said multiradius reflective element and said plano reflective element are supported by said backing plate element of said plano-multiradius reflective element assembly and when said plano-multiradius reflective element assembly is mounted in said exterior sideview mirror assembly on the automobile, and said principal axis of said rearward field of view of said plano reflective element being directed generally parallel to the longitudinal axis of the automobile equipped with the plano-multiradius reflective element assembly and wherein said principal axis of said rearward field of view of said multiradius reflective element is directed generally at an angle downwards to the longitudinal axis of the automobile; and

said multiradius reflective element being positioned diagonally at an outboard upper portion of said plano-multiradius reflective element assembly when said exterior sideview mirror assembly is mounted to the side of the automobile.

2. The exterior sideview mirror system of claim 1, wherein said plano reflective element and said multiradius reflective element are adjacently attached to said backing plate element at a joint, and wherein said plano-multiradius reflective element assembly includes a demarcation element, said demarcation element disposed at said joint to form a demarcation between said plano reflective element and said multiradius reflective element, said demarcation element having a portion visible to a driver of the automobile.

3. The exterior sideview mirror system of claim 2, wherein said demarcation element is dark colored.

4. The exterior sideview mirror system of claim 3, wherein said demarcation element is dark colored with a color selected from the group consisting of black, grey, blue and brown.

5. The exterior sideview mirror system of claim 3, wherein said demarcation element comprises at least one of a polymer material, a tape, a plastic film, a paint, a lacquer and a caulk.

6. The exterior sideview mirror system of claim 5, wherein said demarcation element comprises a polymer material.

7. The exterior sideview mirror system of claim 2, wherein said joint comprises a space between said plano reflective element and said multiradius reflective element.

8. The exterior sideview mirror system of claim 7, wherein said demarcation element is at least partially disposed in said space between said plano reflective element and said multiradius reflective element.

9. The exterior sideview mirror system of claim 2, wherein said demarcation element comprises a wall on said backing plate element, said wall located on said backing plate element at said joint, said wall separating said plano reflective element from said multiradius reflective element.

10. The exterior sideview mirror system of claim 2, wherein said portion visible to a driver of the automobile has a width less than about 4 mm.

11. The exterior sideview mirror system of claim 2, wherein said portion visible to a driver of the automobile has a width less than about 3 mm.

12. The exterior sideview mirror system of claim 2, wherein said portion visible to a driver of the automobile has a width less than about 2 mm.

13. The exterior sideview mirror system of claim 2, wherein said portion visible to a driver of the automobile has a width greater than about 0.5 mm.

14. The exterior sideview mirror system of claim 2, wherein said portion visible to a driver of the automobile has a width greater than about 0.75 mm.

15. The exterior sideview mirror system of claim 2, wherein said portion visible to a driver of the automobile has a width greater than about 1 mm.

16. The exterior sideview mirror system of claim 1, wherein said plano reflective element is supported by said backing plate element by at least one of an adhesive attachment and a mechanical attachment.

17. The exterior sideview mirror system of claim 1, wherein said multiradius reflective element is supported by said backing plate element by at least one of an adhesive attachment and a mechanical attachment.

18. The exterior sideview mirror system of claim 1, wherein said multiradius reflective element is supported by said backing plate element at a location such that, when said exterior mirror assembly is attached to a side of an automobile, at least a portion of said plano reflective element is disposed closer to said side of the automobile than any portion of said multiradius reflective element.

19. The exterior sideview mirror system of claim 1, wherein said multiradius reflective element comprises a bent glass substrate with radii of curvature in the range of from about 4.000 mm to about 50 mm.

20. The exterior sideview mirror system of claim 1, wherein the ratio of the width of said plano reflective element to the width of said multiradius reflective element is greater than 1.

21. The exterior sideview mirror system of claim 1, wherein the ratio of the width of said plano reflective element to the width of said multiradius reflective element is greater than 1.5.

22. The exterior sideview mirror system of claim 1, wherein the ratio of the width of said plano reflective element to the width of said multiradius reflective element is greater than 2.5.

23. The exterior sideview mirror system of claim 1, wherein said angle downwards to the longitudinal axis of the automobile is in the range from about 1 degree to about 10 degrees.

24. The exterior sideview mirror system of claim 1, wherein said angle downwards to the longitudinal axis of the automobile is in the range from about 2 degrees to about 8 degrees.

25. The exterior sideview mirror system of claim 1, wherein said angle downwards to the longitudinal axis of the automobile is in the range from about 3 degrees to about 6 degrees.

26. The exterior sideview mirror system of claim 1, wherein said angle downwards to the longitudinal axis of the automobile is generally set by an angling of a surface of said backing plate element.

27. The exterior sideview mirror system of claim 1, wherein said exterior sideview mirror assembly comprises a door-mounted exterior sideview mirror assembly adapted for attachment to a side of the automobile adjacent a driver seating location of a driver of the automobile and wherein the principal axis of the rearward field of view of said multiradius reflective element is directed generally downwardly towards the road surface adjacent to the driver

seating location at a distance in the range of about 1 foot to about 24 feet to the rear of the driver seating location.

28. The exterior sideview mirror system of claim 1, wherein said exterior sideview mirror assembly comprises a door-mounted exterior sideview mirror assembly adapted for attachment to a side of the automobile adjacent a driver seating location of a driver of the automobile and wherein the principal axis of the rearward field of view of said multiradius reflective element is directed generally downwardly towards the road surface adjacent to the driver seating location at a distance in the range of about 1 foot to about 12 feet to the rear of the driver seating location.

29. The exterior sideview mirror system of claim 1, wherein said exterior sideview mirror assembly comprises a door-mounted exterior sideview mirror assembly adapted for attachment to a side of the automobile adjacent a driver seating location of a driver of the automobile and wherein the principal axis of the rearward field of view of said multiradius reflective element is directed generally downwardly towards the road surface adjacent to the driver seating location at a distance in the range of about 1 foot to about 8 feet to the rear of the driver seating location.

30. The exterior sideview mirror system of claim 1, wherein said exterior sideview mirror assembly comprises a fixedly attached exterior sideview mirror assembly.

31. The exterior sideview mirror system of claim 1, wherein said exterior sideview mirror assembly comprises a break-away exterior sideview mirror assembly.

32. The exterior sideview mirror system of claim 1, wherein said exterior sideview mirror assembly comprises a powerfold exterior sideview mirror assembly.

33. The exterior sideview mirror system of claim 1, wherein said control comprises a memory controller.

34. The exterior sideview mirror system of claim 1, wherein at least one of said plano reflective element and said multiradius reflective element comprises an electro-optic reflective element.

35. The exterior sideview mirror system of claim 1, wherein both said plano reflective element and said multiradius reflective element comprise an electro-optic reflective element.

36. The exterior sideview mirror system of claim 1, wherein said plano reflective element comprises an electro-optical reflective element.

37. The exterior sideview mirror system of claim 36, wherein said electro-optical reflective element comprises an electrochromic reflective element.

38. The exterior sideview mirror system of claim 37, wherein said multiradius reflective element comprises a fixed reflectance mirror reflector.

39. The exterior sideview mirror system of claim 38, wherein said fixed reflectance mirror reflector comprises a bent glass substrate coated with a metallic reflector coating.

40. The exterior sideview mirror system of claim 1, wherein said plano-multiradius reflective element assembly is formed in an integral molding operation.

* * * * *

EXTERIOR MIRROR PLANO-AUXILIARY REFLECTIVE ELEMENT ASSEMBLY

This is a continuation-in-part of U.S. Pat. application Ser. No. 09/478,315, filed Jan. 6, 2000, entitled "EXTERIOR MIRROR PLANO-AUXILIARY REFLECTIVE ELEMENT ASSEMBLY", which is incorporated by reference herein in its entirety.

5

TECHNICAL FIELD AND BACKGROUND OF THE INVENTION

The present invention relates to exterior sideview mirror assemblies suitable for use on an automobile, and more specifically, to plano-auxiliary reflective element assemblies for use in automobile exterior sideview mirror assemblies.

Automobiles are typically equipped with an interior rearview mirror assembly
10 (adapted for providing a rearward field of view immediately rearward of the vehicle, typically principally in the road lane the vehicle is traveling in) and at least one exterior sideview mirror assembly attached to the side of the vehicle (typically adjacent a front side window portion). The exterior side view mirror assembly typically comprises a reflective element adapted to provide a rearward field of view of the side lane adjacent the vehicle so as
15 to allow the driver see whether a side approaching vehicle is present when the driver is contemplating a lane change. Conventionally, automobiles are equipped with a driver-side exterior mirror assembly and, very often, with a passenger-side exterior sideview mirror assembly mounted to the side of the automobile body opposite to that of the driver-side assembly. While the combination of an interior rearview mirror with a driver-side exterior
20 mirror (and especially in a three-mirror system comprising an interior rearview mirror with a driver-side exterior mirror and a passenger-side exterior mirror) works well in many driving situations, rear vision blind spots present a potential safety hazard while driving. A rear vision blind spot is an area adjacent the side of an automobile where a view of another vehicle (overtaking on that side) is not captured in the rearward field of view of the exterior
25 mirror reflector on that side. This presents a potential safety hazard as the driver, upon checking the view in the exterior sideview mirror and seeing no overtaking vehicle therein, may deem it safe to initiate a lane change, unaware that there is a vehicle immediately adjacent in a blind-spot of the exterior mirror reflector.

EXHIBIT C

Various attempts have been made conventionally to minimize and/or eliminate exterior mirror blind-spots on vehicles. One approach is to make the exterior mirror reflector larger, and particularly wider with respect to the vehicle body. By increasing the width of the exterior mirror reflector, it has a wider field of view rearwards, and hence the reflector blind-spot is reduced. While use of a wide exterior mirror reflector is an option for trucks, buses and commercial vehicles, increasing the width of the reflector used in an exterior sideview mirror assembly mounted on automobiles (such as sedans, station wagons, sports cars, convertibles, minivans, sports utility vehicles, pick-up trucks and similar passenger carrying automobiles) is often not an option. In such domestic automobiles, increasing the width of the exterior mirror reflector increases the size of the exterior sideview mirror assembly with a concomitant increase in aerodynamic drag, increase in fuel consumption, increased difficulty in parking in tight parking spaces, and increased reflector vibration. Use of a non-flat, curved exterior mirror reflector is commonly used to increase rearward field of view without increasing reflector size.

While working well to increase field of view, use of a curved reflector (such as a convex, spherically-curved reflector) has disadvantages. The field of view rearward increases as the degree of curvature of the bent substrate increases (i.e., the field of view rearward increases as the radius of curvature of the bent substrate decreases). However, such wide-angle mirrors have non-unit magnification and distance perception rearward is distorted. For this reason, convex (spherically-bent) exterior mirror reflectors are required in some countries (such as the United States) to carry a safety warning "OBJECTS IN MIRROR ARE CLOSER THAN THEY APPEAR". Distance perception is particularly important for a driver-side exterior mirror. Indeed, Federal Vehicle Safety Standard No: 111 in the United States (the entire disclosure of which is hereby incorporated by reference herein) requires that the driver-side exterior mirror reflector exhibit unit magnification, and places restrictions on the radius of curvature allowed for any bent passenger-side mirror as well as requiring a safety warning be placed thereon. As an improvement over spherically bent/convex mirror reflectors, aspherical or multiradius mirror reflectors (such as are disclosed in U.S. Pat. Nos. 4,449,786 and 5,724,187, the entire disclosures of which are hereby incorporated by reference herein) have been developed. Such mirrors are widely used in Europe and Asia for both driver-side exterior mirror reflectors and for passenger-side exterior mirror reflectors. The aspherical or multiradius mirror reflectors typically have a

less curved (larger radius of curvature) reflective region that is inboard or closest to the driver when mounted on a vehicle and, usually separated by a demarcation line or the like, have a more curved (smaller radius of curvature) region that is outboard or farthest from the driver when mounted on a vehicle. However, such aspherical or multiradius reflectors do not have unit magnification and so cannot be used when unit magnification is mandated (such as by
5 FMVSS 111, referenced above).

To supplement a flat driver-side exterior mirror reflector, an auxiliary and separate bent reflector is sometimes incorporated into the driver-side exterior sideview mirror assembly. However, this is often not suitable for passenger automobiles because of the extra
10 space required in the sideview mirror assembly to accommodate an auxiliary reflector element. Also, in most passenger automobiles, the position of the side view mirror reflector is adjustable by the driver (such as by a hand-adjust, or by a manually adjustable cable such as a Bowden cable or by an electrically operable actuator, as known in the art) in order to provide to that driver his or her desired rearward field of view, which ill-suits use of a
15 separate, auxiliary reflector. Likewise, addition of stick-on blind-spot mirror reflectors (such as are commonly sold in automotive parts stores and the like) onto an automobile exterior sideview mirror reflector has disadvantages, including obscuring field of view of the automobile mirror reflector and adding to mirror element vibration.

There is thus a need to provide an automobile exterior sideview reflective
20 element, and particularly a driver-side automobile exterior sideview reflective element, that overcomes the disadvantages above and that provides the driver of the automobile with a distortion-free field of view with unit magnification that is supplemented with a wide-angle view of a side lane blind spot, and there is a need that this be provided in a unitary reflective element assembly module suitable to mount onto, and be adjusted by, the mirror reflector
25 adjustment mechanism (such as an electrically operated, motorized actuator) provided in the exterior sideview mirror assembly.

SUMMARY OF THE INVENTION

According to the present invention, an automobile exterior sideview mirror system includes an exterior sideview mirror assembly having a reflective element assembly.
30 The reflective element assembly includes a first reflective element and a second reflective element, which together provide an increased field of view for the exterior side mirror assembly.

In one form of the invention, an automobile exterior side mirror system includes an exterior side mirror assembly, which is adapted for attachment to a side of an automobile. The exterior sideview mirror assembly includes a reflective element assembly having a plano reflective element, which forms a first reflective element, and a multiradiused reflective element which forms a second reflective element. The reflective element assembly is mounted to an actuator, which moves the reflective element assembly to position the rearward field of view of the reflective element assembly. The reflective element assembly further includes a frame element assembly to which the first and second reflective elements are mounted and which orients the second reflective element such that it has a viewing range which spans outwardly and downwardly with respect to the first reflective element to thereby provide an increased field of view for the exterior sideview mirror assembly.

In one aspect, the first reflective element and the second reflective element are adjacently attached to the frame element assembly at a joint. The reflective element assembly further includes a demarcation element disposed at its joint to form a demarcation between the first and second reflective elements that is visible to the driver. In a further aspect, the frame element assembly includes a bezel portion which extends around the first reflective element, with the demarcation element comprising a segment of the first bezel portion.

In another aspect, the second reflective element comprises a bent glass substrate with radii of curvature in the range of about 4000 mm to about 100 mm.

In yet another aspect, the frame element assembly includes a frame, with the first and second reflective elements being mounted in the frame. The multiradiused reflective element is mounted to the frame at an outboard position, with the plano reflective element being positioned adjacent the multiradiused reflective element and at an inboard position with respect to the multiradiused reflective element when the exterior side mirror assembly is mounted to an automobile. In a further aspect, the plano reflective element is mounted to the frame by a backing plate, which is preferably adapted to mount to the actuator.

In other aspects, the first reflective element includes a rearward field of view having a principal axis, which is different from and angled to a principal axis of the rearward field of view of the second reflective element when the reflective element assembly is mounted in the exterior sideview mirror assembly. The principal axis of the rearward field of view of the second reflective element is directed generally outwardly and downwardly with

respect to a longitudinal axis of the automobile when the exterior side mirror system is mounted to an automobile. For example, the principal axis of the rearward field of view of the second reflective element may form a downward angle with respect to the principal axis of the rearward field of view of the first reflective element in the range from about .75° to about 5°, or in a range of about 1.5° to about 3.5°, in a range of about 2° to about 3°.

In other aspects, the principal axis of the second reflective element forms an outward angle with respect to the principal axis of the rearward field of view of the first reflective element in a range of about 0.75° to about 5°, or in a range of about 1° to about 3°, or in a range of about 1.25° to about 2.5°.

According to another form of the invention, an automobile exterior side mirror system includes an exterior side mirror assembly, which is adapted for attachment to a side of an automobile. The exterior side mirror assembly includes a mirror casing, a reflective element assembly, and an actuator. The reflective element assembly includes a frame element assembly, a first reflective element having a unit magnification, and a second reflective element having a multiradiused curvature. The frame element assembly mounts the first reflective element and the second reflective element in the mirror casing and is adapted to mount to the actuator, which adjusts the orientation of the reflective element assembly. The first reflective element has a first rearward field of view with a first principal axis, and the second reflective element has a second rearward field of view with a second principal axis, with the second principal axis being angled outwardly and downwardly with respect to the first principal axis.

In one aspect, the second principal axis is angled outwardly from the first principal axis at an angle in a range of about 0.75° to about 5°, or in a range of approximately 1° to about 3°, or at an angle in a range of about 1.25° to about 2.5°.

In another aspect, the second principal axis is angled downwardly from the first principal axis at an angle in a range of approximately 0.75° to about 5°, or in a range of about 1.5° to about 3.5°, or at an angle in a range of about 2° to about 3°.

In another aspect, the frame includes a support surface for the second reflective element, with the support surface angling the second principal axis of the second reflective element.

In yet another form of the invention, an automobile exterior sideview mirror system includes an exterior sideview mirror assembly, which is adapted for attachment to a

side of an automobile. The mirror assembly includes an actuator and a reflective element assembly. The reflective element assembly includes a frame element assembly, a first reflective element, and a second reflective element. The frame element assembly is adapted to mount to the actuator and includes a frame and a support surface for the second reflective element. The actuator adjusts the position of the reflective element assembly to thereby adjust the viewing angle of the sideview mirror system. The support surface angles the second reflective element downwardly and forwardly of the first reflective element when the mirror assembly is mounted to an automobile whereby the second reflective element provides a viewing range which spans outwardly and downwardly with respect to the automobile to thereby provide an increased field of view for the exterior sideview mirror assembly.

In one aspect, the support surface is provided by a plate element, for example a solid plate element or a foraminous plate element. In other aspects, the support surface is provided by a frame.

In further aspects, the frame includes a first bezel portion and a second bezel portion, with the first bezel portion extending around the first reflective element, and the second bezel portion extending around the second reflective element. In one form, the second bezel portion is angled forwardly with respect to the first bezel portion when said exterior sideview mirror assembly is mounted to a side of an automobile.

In another aspect, the second reflective element is located outboard of the first reflective element.

These and other advantages, features, and modifications will become more apparent when reviewed in conjunction with the drawings and the detailed description which follows.

BRIEF DESCRIPTION OF THE DRAWINGS

FIG. 1 is a perspective view of an automobile equipped with exterior sideview mirror assemblies according to this present invention;

FIG. 2 is a top plan partial fragmentary view of the driver's side exterior rearview mirror assembly of FIG. 1;

FIG. 3 is an enlarged sectional view of a plano-multiradius reflective element assembly of the mirror assembly in FIG. 2;

FIG. 4 is an enlarged sectional view of a demarcation element of the plano-multiradius reflective element assembly of FIG. 3;

FIG. 5A-5H illustrate views of various locations for a plano reflective element and an auxiliary reflective element according to this present invention;

FIG. 6 is a sectional view of a second embodiment of a plano reflective element assembly according to the present invention including a demarcation element formed as a dividing wall in a backing plate element;

FIG. 6A is a cross-section taken along line XX of FIG.6;

FIG. 6B is a cross-sectional view taken along line YY of FIG.6;

FIG. 7 is a schematic of a third embodiment of a plano-auxiliary reflective element assembly according to this present invention;

FIG. 8 is a front elevation view of another embodiment of a plano reflective element assembly according to the present invention;

FIG. 9 is an exploded perspective view of the plano reflective element assembly of FIG. 8;

FIG. 10 is an end view of the plano reflective element assembly of FIG. 8 as viewed from line X-X of FIG. 8;

FIG. 11 is a top view of the plano reflective element assembly of FIG. 8 as viewed from line XI-XI of FIG. 8;

FIG. 12 is a schematic representation of the plano reflective element assembly of FIG. 8 illustrating the orientation of the reflective element;

FIG. 13 is another schematic representation of the orientation of the reflective elements of the plano reflective element in FIG. 8;

FIG. 14 is a diagram illustrating the range of viewing of the reflective elements of the plano reflective element assembly of FIG. 8; and

FIG. 15 is a perspective view of another embodiment of an exterior rearview mirror system of the present invention.

DETAILED DESCRIPTION OF THE PREFERRED EMBODIMENTS

As illustrated in FIG. 1, passenger automobile 10 (which may be a sedan, a station-wagon, a sports car, a convertible, a minivan, a sports utility vehicle, a pick-up truck or a similar passenger carrying non-commercial, personal transportation automobile) includes an interior rearview mirror assembly 18 positioned within interior vehicle cabin 25. Interior vehicle cabin 25 further includes a steering wheel 16, a driver seat 20 positioned at

steering wheel 16, a front passenger seat 21 adjacent to driver seat 20 in the front portion of cabin 25, and a rear passenger seat 23 in the rear portion of cabin 25. Automobile 10 further includes a driver-side exterior sideview mirror assembly 12 and a passenger-side exterior sideview mirror assembly 14, each adapted for attachment to opposing sides of automobile body 11, most preferably adjacent to the seating position of the driver seated in driver seat 20 for driver-side assembly 12 and adjacent to the front passenger seat 21 for passenger-side assembly 14. Exterior sideview mirrors, mounted as shown in FIG. 1 close to the driver seating location, are commonly referred to as door-mounted exterior sideview mirror assemblies. Driver-side exterior sideview mirror assembly 12 includes, as illustrated in FIG. 2, a plano-multiradius exterior sideview reflective element assembly 30. Plano-multiradius reflective element assembly 30 is mounted to a reflective element positioning actuator 36. The orientation of plano-multiradius reflective element assembly 30, and hence its rearward field of view, is adjustable by actuator 36 in response to control 37. Control 37 can comprise a handset control that allows the driver manually move the orientation of plano-multiradius reflective element assembly 30 within exterior mirror housing 40 (such as by a lever control or by a cable control) and hence reposition the rearward field of view of plano-multiradius reflective element assembly 30. Alternately, when actuator 36 comprises an electrically actuated actuator that is electrically operable incorporating at least one motor, control 37 can comprise a switch (which, preferably, is operable under control of the driver seated in cabin 25) or control 37 can comprise a memory controller, as known in the automotive mirror art, that controls actuator 36 to move the position of plano-multiradius reflective element assembly 30 to a pre-set orientation that suits the rearward field of view preference of an individual driver. Actuator 36 is mounted to bracket 38 which attaches to vehicle body side 11. Plano-multiradius reflective element assembly 30 is positionable by actuator 36 within exterior mirror housing 40.

Plano-multiradius reflective element assembly 30, as shown in FIG. 3, comprises a plano element 50 and a separate multiradius element 55. Preferably, plano element 50 is adjacent to multiradius element at a joint. At their joint, plano element 50 and separate multiradius element 55 can touch leaving substantially no gap or space therebetween, or plano element 50 and separate multiradius element 55 can be spaced apart at their joint by a space or gap, as in FIG. 3. Plano element 50 and multiradius element 55 are both mounted to surface 59 of, and are both supported by, a single backing plate element 60.

Plano element 50 and multiradius element 55 are demarcated apart by demarcation element 65. Surface 61 of backing plate element 60 is preferably adapted to attach, such as by attachment member 64, to actuator 36 when plano-multiradius reflective element assembly 30 is mounted in driver-side exterior sideview mirror assembly 12 (and/or in passenger-side exterior side view mirror assembly 14) such that plano element 50 and multiradius element 55 are adjusted and positioned in tandem and simultaneously when the driver (or alternatively, when a mirror memory system, as is conventional in the rearview mirror arts) activates actuator 36 to reposition the rearward field of view of plano-multiradius reflective element assembly 30. Thus, since elements 50, 55 are part of plano-multiradius reflective element assembly 30, movement of plano-multiradius reflective element assembly 30 by actuator 36 simultaneously and similarly moves plano element 50 and multiradius element 55.

Plano element 50 preferably comprises a flat reflector-coated glass substrate having unit magnification, and comprises a reflective surface through which the angular height and width of the image of an object is equal to the angular height and width of the object when viewed at the same distance (except for flaws that do not exceed normal manufacturing tolerances). Plano element 50 may comprise a conventional fixed reflectance mirror reflector or it may comprise a variable reflectance mirror reflector whose reflectivity is electrically adjustable. For example, plano element 50 may comprise a flat glass substrate coated with a metallic reflector coating such as a chromium coating, a titanium coating, a rhodium coating, a metal alloy coating, a nickel-alloy coating, a silver coating, an aluminum coating (or any alloy or combination of these metal reflectors). The metal reflector coating of plano element 50 may be a first surface coating (such as on surface 66) or a second surface coating (such as on surface 67), as such terms are known in the mirror art. The reflector coating on plano element 50 may also comprise a dielectric coating, or a multilayer of dielectric coatings, or a combination of a metal layer and a dielectric layer to form automotive mirror reflectors as known in the automotive mirror art. If a variable reflectance reflector element, plano element 50 preferably comprises an electro-optic reflector element and, most preferably, an electrochromic reflector element.

When mounted into exterior side view mirror assembly 12 and/or 14, plano-multiradius reflective element assembly 30 is preferably orientated so that at least a portion of (more preferably a substantial portion of) the reflector surface of plano element 50 is

positioned closer to the vehicle body (and hence to the driver) than any portion of the reflector surface of multiradius element 55. Thus, and referring to FIG. 3, side A of plano element 50 of plano-multiradius reflective element assembly 30 is positioned closer to the driver than side D of multiradius element 55 when plano-multiradius reflective element
5 assembly 30 is mounted on an automobile. Also, when mounted into exterior side view mirror assembly 12 and/or 14, surfaces 66, 68 of plano-multiradius reflective element assembly 30 face rearwardly in terms of the direction of vehicle travel.

Multiradius element 55 of plano-multiradius reflective element assembly 30 preferably comprises a curved/bent mirrored glass substrate. The degree of curvature
10 preferably increases (and hence the local radius of curvature decreases) across the surface of multiradius element 55 with the least curvature (largest radius of curvature) occurring at the side of multiradius element 55 (side C in FIG. 3) positioned adjacent its joint to plano element 50 when both are mounted on backing plate element 60. Thus, and referring to FIG. 3, the local radius of curvature at side C of multiradius element 55, when mounted on
15 backing plate element 60, is larger than at side D. Also, the local radius of curvature preferably progressively decreases across multiradius element 55 from side C to side D. Preferably, the local radius of curvature at side C of multiradius element 55 is at least about 1000 mm; more preferably is at least about 2000 mm and most preferably is at least about 3000 mm whereas the local radius of curvature at side D of multiradius element 55 is,
20 preferably, less than about 750 mm, more preferably less than about 350 mm; most preferably less than about 150 mm. Preferably, multiradius element 55 comprises a bent glass substrate with radii of curvature in the range of from about 4000 mm to about 50 mm. The multiradius prescription for the multiradius element to be used in a particular exterior mirror assembly can vary according to the specific field of view needs on a specific automobile model.

25 The total field of view rearwardly of the automobile of the plano-auxiliary reflective element assembly (which is a combination of the field of view of the plano reflective element and of the auxiliary reflective element) preferably generally subtends an angle of at least about 20° (and more preferably, generally subtends an angle of at least about 25° and most preferably, generally subtends an angle of at least about 30°) with respect to the
30 side of an automobile to which is attached an exterior sideview mirror assembly equipped with the plano-auxiliary reflective element assembly.

Multiradius element 55 may comprise a conventional fixed reflectance mirror reflector or it may comprise a variable reflectance mirror reflector whose reflectivity is electrically adjustable. For example, multiradius element 55 may comprise a flat glass substrate coated with a metallic reflector coating such as a chromium coating, a titanium coating, a rhodium coating, a metal alloy coating, a nickel-alloy coating, a silver coating, an aluminum coating (or any alloy or combination of these metal reflectors). The metal reflector coating of multiradius element 55 may be a first surface coating (such as on surface 68) or a second surface coating (such as on surface 69), as such terms are known in the mirror art. The reflector coating on multiradius element 55 may also comprise a dielectric coating, or a multilayer of dielectric coatings, or a combination of a metal layer and a dielectric layer to form automotive mirror reflectors as known in the automotive mirror art. If a variable reflectance reflector element, multiradius element 55 preferably comprises an electro-optic reflector element and, most preferably, an electrochromic reflector element.

Also, it is preferable that the thickness of plano element 50 and multiradius element 55 be substantially the same in dimension so that their respective outer surfaces, 66 and 68, are substantially coplanar so that a driver can readily view images in either or both elements. The thickness dimension of elements 50, 55 is determined by the thickness of the substrate (or in the case of laminate-type electrochromic reflective elements, the thickness of the two substrates between which the electrochromic medium is disposed). For example, plano element 50 and/or multiradius element 55 can comprise a reflector coated glass substrate or panel of thickness preferably equal to or less than about 2.3 mm, more preferably equal to or less than about 1.6 mm, most preferably equal to or less than about 1.1 mm. Use of a thinner substrate is beneficial in terms of improving the overall stability/vibration performance of the image seen in plano-multiradius reflective element assembly 30 when mounted to an automobile.

The reflector area of plano element 50 is preferably larger than that of multiradius element 55. Preferably, the width dimension of plano element 50 is larger than the width dimension of multiradius element 55 (both width dimensions measured at their respective widest dimension and with the width of the respective element being gauged with the respective element oriented as it would be orientated when mounted on the automobile). Thus, and referring to FIG. 3, the distance from side A to side B of plano element 50 is larger than the distance from side C to side D of multiradius element 55. Thus, the ratio of the

width of plano element 50 to the width of multiradius element 55 is preferably greater than 1; more preferably greater than 1.5; most preferably greater than 2.5 in order to provide a large, unit magnification plano element 50 as the principal rear viewing portion of plano-multiradius reflective element assembly 30 and providing multiradius element 55 as a smaller, auxiliary, separate, wide-angle viewing portion of plano-multiradius reflective element assembly 30. For plano-multiradius reflective element assemblies to be mounted to the exterior sideview assemblies of passenger automobiles used non-commercially and for non-towing purpose, the width of plano element 50 (at its widest dimension) is preferably in the range of from about 50 mm to about 225 mm; more preferably in the range of from about 75 mm to about 175 mm; most preferably in the range of from about 100 mm to about 150 mm.

Backing plate element 60 is preferably a rigid polymeric substrate capable of supporting plano element 50 and multiradius element 55. Backing plate element 60 comprises a flat portion (generally between E and F as shown in FIG. 3) that corresponds to and is aligned with plano element 50. Backing plate element 60 also comprises a curved portion (generally between G and H as shown in FIG. 3) that corresponds to and is aligned with multiradius element 55. Preferably, curved portion G-H of multiradius element 55 is fabricated with a multiradius prescription that is substantially the same as the multiradius prescription of multiradius element 55. Backing plate element 60 is formed as a single element to which elements 50 and 55 are separately attached. Preferably, backing plate element 60 is formed by injection molding of a thermoplastic or a thermosetting polymer resin. Materials suitable to use for backing plate element 60 include unfilled or filled polymeric materials such as glass and/or mineral filled nylon or glass and/or mineral filled polypropylene, ABS, polyurethane and similar polymeric materials. For example, backing plate element 60 can be formed of ABS in an injection molding operation. Plano element 50 can be cut from a stock lite of flat chromium mirror-coated 1.6 mm thick glass. Multiradius element 55 can be cut from a stock lite of multiradiusly-bent chromium mirror-coated 1.6 mm thick glass. Plano element 50 and multiradius element 55 can then be attached (such as by an adhesive attachment such as an adhesive pad or by mechanical attachment such by clips, fasteners or the like) to the already molded backing plate element 60. Alternatively, plano element 50 and multiradius element 55 can each be individually loaded into an injection molding tool. Once loaded, a polymeric resin (or the monomers to form a

polymeric resin) can be injected into the mold in order to integrally form backing plate element 60 with elements 50, 55 integrally molded thereto. Integral molding of the backing plate element to plano element 50 and multiradius element 55 (along with any other elements such as the demarcation element 65) in a single integral molding operation, is a preferred
5 fabrication process for plano-multiradius reflective element assembly 30.

Plano-multiradius reflective element assembly 30 further preferably includes demarcation element 65 that functions to delineate and demarcate the plano region of the assembly from the wide-angle, multiradius region and also preferably functions to prevent ingress of debris, dirt, water and similar contaminants (such as road splash, car wash spray,
10 rain, snow, ice, leaves, bugs and similar items that plano-multiradius reflective element assembly 30 would be subject to when mounted and used on an automobile) into any gap between plano element 50 and multiradius element 55 when both are attached to backing plate element 60. Optionally, at least a portion of demarcation element 65 can be disposed in any gap between plano element 50 and multiradius element 55 at their joint on backing plate
15 element 60. Preferably, demarcation element 65 is formed of a polymeric material that is dark colored (such as black or dark blue or dark brown or dark grey or a similar dark color) such as a dark colored polypropylene resin or a dark colored nylon resin or a dark colored polyurethane resin or a dark colored polyvinyl chloride resin or a dark colored silicone material. Most preferably demarcation element 65 is formed of an at least partially
20 elastomeric material (such as silicone, or EPDM, or plasticized PVC or the like) in order to provide a degree of vibration dampening for elements 50, 55. As shown in FIG. 4, demarcation element 65 optionally includes a crown portion 70 that includes wing portions 73, 73' and a stem portion 71. Stem portion 71 preferably has a cross-sectional width CCC of less than about 4 mm, more preferably less than about 3 mm and, most preferably less than
25 about 2 mm. Crown portion 70 preferably is dimensioned to not protrude substantially beyond surfaces 66, 68 of elements 50, 55 when demarcation element 65 is installed between elements 50 and 55. Also, wings 73, 73' are preferably dimensioned to protrude (most preferably slightly) onto surfaces 66, 68 of elements 50, 55 when demarcation element 65 is installed between elements 50 and 55 in order to provide a weather barrier seal and/or to at
30 least partially accommodate any dimensional tolerances of elements 50, 55 that could lead to variation in the inter-element gap between sides C and B. While the demarcation element shown in FIG. 4 is one embodiment, other constructions are possible including a demarcation

element that has minimal or no crown portion. Likewise, a demarcation element can have little or no stem portion, especially when the joint between plano element 50 and multiradius element 55 includes no gap to receive a stem. Also, where a gap at the plano to multiradius joint exists, any stem of the demarcation element can at least partially be disposed in such gap so as to at least partially fill the gap (or it can optionally substantially fill the gap).
5
Optionally, demarcation element 65 is fabricated by injection molding of a polymeric resin. After plano element 50 and multiradius element 55 have been attached to backing plate element 60, a separately formed demarcation element 65 can then be inserted (and secured such as by an adhesive or by a mechanical attachment such as by a fastener) into a space
10 between elements 50 and 55. Note that, optionally, side B of plano element 50 and side C of multiradius element 55 can touch (leaving substantially no gap or space therebetween). In such a situation, demarcation element 65 can comprise a dark colored strip such as of a tape or of a plastic film that covers the joint between elements 50 and 55. Alternatively, demarcation element 65 can comprise a preferably dark-colored paint, lacquer, caulk or
15 similar material that can be applied to, and that can preferably fill into, the joint between elements 50 and 55. The width of the portion of demarcation element 65 that is visible to the driver is preferably less than about 4 mm, more preferably less than about 3 mm and most preferably less than about 2 mm, but is equal to or greater than about 0.5 mm, more preferably is equal to or greater than about 0.75 mm, most preferably is equal to or greater
20 than about 1 mm in order to provide adequate demarcation of the plano region from the multiradius radius region without unduly obscuring the rearward field of view of the respective elements. Optionally, demarcation element 65 can be formed as part of backing plate element 60 such as by forming demarcation element 65 as a wall structure of the backing plate element that partitions backing plate element 60 into two regions: A first
25 region adapted to receive plano reflective element 50 and a separate and adjacent second region adapted to receive multiradius reflective element 55.

Thus, and referring to FIG. 6, a second embodiment of plano-multiradius reflective element assembly 130 may include a backing plate element 160 which comprises a plate molded from a polymer resin (such as a polyolefin such as polypropylene or such as
30 ABS or nylon) with a demarcation element 165 that is molded as a wall structure that partitions backing plate element 165 into a first region (from CC to BB) adapted to receive and accommodate plano reflective element 150 and into a second region (from BB to AA)

adapted to receive and accommodate wide-angle optic multiradius reflective element 155. Note that section AA to BB of backing plate element 160 is angled to section BB to CC. Such angling of the auxiliary reflective element relative to the plano element can be advantageous in allowing the auxiliary reflective element view a portion of the road adjacent the automobile that is in a blind spot of the plano reflective element. In this regard, it is preferable that the multiradius element be angled away from the plane of the plano element, as shown in FIG. 6 by the angling of section AA to BB to section BB to CC.

Preferably, demarcation element 65 is formed in an integral molding operation, along with formation of backing plate element 60, and attachment of elements 50, 55 thereto. For example, plano element 50 and multiradius element 55 can each be individually loaded into an injection molding tool. Once loaded, a polymeric resin (or the monomers to form a polymeric resin) can be injected into the mold in order to integrally form backing plate element 60 with elements 50, 55 integrally molded thereto and, in the same molding operation and in the same tool, also form by molding the demarcation element. Integral molding of the backing plate element to plano element 50 and multiradius element 55 along with creation in the single molding operation of demarcation element 65 (along with any other elements such as attachment member 64) in a single integral molding operation, is a preferred fabrication process for plano-multiradius reflective element assembly 30. By loading all the sub components of plano-multiradius reflective element assembly 30 into a molding tool, and then injecting polymeric resin to form the backing plate, demarcation member and any attachment member, a substantially complete or fully complete plano-multiradius reflective element assembly can be unloaded from the tool at the completion of the integral molding operation (as known in the molding art), thus enabling economy in manufacturing and accommodation of any dimensional tolerances in the sub components. Where integral molding is so used, it is preferable to use a reactive molding operation such as reactive injection molding of a urethane as such reactive injection molding operations occur at relatively modest temperatures.

Plano element 50 and/or multiradius element 55 can comprise a heater element, as known in the automotive mirror art, that is operable to deice/demist surfaces 66, 68. Such heater elements are conventional and can comprise a positive temperature coefficient heater pad, a resistive heater element and/or a conductive coating. Plano element 50 and/or multiradius element 55 can also optionally comprise a scatterproofing member, as

known in the automotive mirror art, such as an adhesive tape, to enhance safety in an accident.

Also, plano element 50 and/or multiradius element 55 can comprise a variable reflectance electro-optic element such as an electrochromic mirror reflector. Thus, both
5 element 50 and element 55 can comprise an electrochromic mirror element or either of element 50 and element 55 can comprise an electrochromic mirror element and the other can comprise a fixed reflectance non-variable reflectance mirror element such as a metal reflector coated glass panel such as a chromium coated glass substrate. Also, if both plano element 50 and multiradius element 55 comprise an electro-optic element such as an electrochromic
10 mirror element capable of electrically dimmable reflectivity, both elements 50, 55 can dim together and in tandem under control of a common dimming control signal (typically provided by an electro-optic automatic dimming interior mirror assembly mounted in the cabin of the automobile and equipped with photosensors to detect incident glare and ambient light). Alternately, if both plano element 50 and multiradius element 55 comprise an electro-
15 optic element such as an electrochromic mirror element capable of electrically dimmable reflectivity, element 50 can dim independently of element 55 (such as is disclosed in U.S. Pat. No. 5,550,677, the entire disclosure of which is hereby incorporated by reference herein). If either or both of elements 50, 55 comprise an electrochromic element, preferably, the electrochromic reflective element comprises a front substrate and a rear substrate with an
20 electrochromic medium disposed between, such as a solid polymer matrix electrochromic medium such as is disclosed in U.S. Pat. application Ser. No. 09/350,930, filed July 12, 1999, entitled "ELECTROCHROMIC POLYMERIC SOLID FILMS, MANUFACTURING ELECTROCHROMIC DEVICES USING SUCH FILMS, AND PROCESSES FOR MAKING SUCH SOLID FILMS AND DEVICES" to Desaraju V. Varaprasad et al., or such
25 as is disclosed in U.S. Pat. Nos. 5,668,663; 5,724,187; 5,910,854; and 5,239,405, the entire disclosures of which are hereby incorporated by reference herein. Most preferably, in such laminate-type electrochromic mirror reflective elements, the front substrate comprises a glass plate of thickness less than about 1.6 mm, most preferably about 1.1 mm thickness or lower, and the rear substrate comprises a glass plate of thickness equal to or greater than about
30 1.6mm, more preferably greater than about 1.8 mm thickness, most preferably equal to or greater than about 2.0 mm thickness. The rearmost surface of the rear substrate (the fourth surface as known in the mirror art) is reflector coated with a high reflecting metal film such

as of aluminum or silver, or an alloy of aluminum or silver. Most preferably, the front-most surface of the rear substrate (the third surface as known in the mirror art) is reflector coated with a high reflecting metal film such as of aluminum or silver, or an alloy of aluminum or silver.

5 Backing plate element 65 of plano-multiradius reflective element assembly 30 is optionally equipped on its rearmost surface with attachment member 64 to facilitate attachment to the reflector-positioning actuator of the exterior sideview mirror assembly that plano-multiradius reflective element assembly 30 is mounted to. Attachment of plano-multiradius reflective element assembly 30 to the actuator can be by mechanical attachment
10 such as by a tab, clip or fastener, or may be by adhesive attachment such as by a silicone adhesive, a urethane adhesive or a similar adhesive material such as a tape coated on both surfaces with a pressure sensitive adhesive to form a “double-sticky” tape. The exterior sideview mirror assembly, on whose mirror reflector-positioning actuator the plano-multiradius reflective element assembly is mounted, can be a fixedly attached exterior
15 sideview mirror assembly, a break-away exterior sideview mirror assembly and a powerfold exterior sideview mirror assembly, as known in the automotive mirror art.

FIGS. 5A-5H shows various arrangements of multiradius reflective element 55 relative to its adjacent plano reflective element 50 (with demarcation element 65 disposed at their joint). In FIGS. 5A, 5B, 5C, 5E and 5F, plano element 50 is mounted wholly inboard of
20 multiradius element 55. Thus, in FIGS. 5A, 5B, 5C, 5E and 5F, plano element 50 would be disposed closer to the vehicle body (and hence to the driver) than multiradius element 55 when plano-multiradius reflective element assembly 30 was mounted in an exterior sideview mirror attached to a side of an automobile. Therefore, in FIGS. 5A, 5B, 5C, 5E and 5F, plano element 50 would be mounted inboard relative to the side of the automobile and
25 multiradius element 55 would be mounted outboard relative to the side of the automobile. In general, the location of the multiradius reflective element in the outboard, upper portion of the plano-multiradius reflective element assembly, as in FIGS. 5B and 5E, is preferred as this allows the plano portion provide a desired rearward field of view along the side of the vehicle. The configuration as shown in FIG. 5G (where the multiradius reflective element is
30 along the inboard side of the assembly) is also desirable as this allows the driver view the side of the vehicle (something many drivers desire in order to have a frame of reference for

their rearward field of view) while facilitating having a wide field of view for the plano portion.

5 Unlike trucks, busses and commercial vehicles the size of an exterior sideview mirror assembly suitable for use on an automobile (and especially when the automobile is not towing a trailer or the like) is restricted. Automobiles generally are non-commercial vehicles intended for personal transportation. Automobiles typically carry 5 passengers or less, although minivans and large sports utility vehicles (which are classified herein as automobiles) can have seat accommodation for up to 10 passengers (although accommodation for 7 passengers or less is more common). The tandem mounting of a plano element of unit magnification and a separate auxiliary element onto a common, single 10 backing plate element, and the mounting of this backing plate element onto an actuator of an exterior sideview mirror assembly so that a driver can simultaneously and similarly move the auxiliary element and the plano element so as to position their respective rearward fields of view, and to achieve this within the relatively restricted space available in a standard automobile-sized exterior sideview mirror assembly is an important element of this present 15 invention. By utilizing a plano element of unit magnification in the plano-multiradius reflective element assembly, and by sizing the reflector area of the plano element larger than the reflector area of the multiradius element and, preferably, by sizing the reflector area of the plano element at a sufficiently large size that the rearward field of view provided by the plano element alone meets and satisfies the minimum field of view requirement mandated by an 20 automaker specification and/or a government regulation, the need to provide a safety warning indicia such as "OBJECTS IN MIRROR ARE CLOSER THAN THEY APPEAR" in the plano element and/or in the multiradius element can be obviated. Preferably, the plano element comprises a reflector surface area of a size sufficient, when mounted as part of a plano-multiradius reflective element assembly in a driver-side exterior sideview mirror 25 assembly on an automobile, to provide the driver of the automobile a view of a level road surface extending to the horizon from a line, perpendicular to a longitudinal plane tangent to the driver's side of the automobile at the widest point, extending 8 feet out from the tangent plane 35 feet behind the driver's eyes (at a nominal location appropriate for any 95th percentile male driver or at the driver's eye reference points established in Federal Motor Vehicle Standard No. 104), with the driver seated in the driver's seat and with the driver's 30 seat in the rearmost position. Also, preferably, the aspect ratio of the plano-multiradius

reflective element assembly (defined as the ratio of its largest vertical dimension to its largest horizontal dimension, measured with the plano-multiradius reflective element assembly oriented as it would be oriented when mounted in an exterior sideview mirror assembly on an automobile, and with “horizontal” being generally parallel with the road surface the automobile travels on and “vertical” being generally perpendicular to the road surface the automobile travels on) is preferably less than 1, more preferably less than 0.8, most preferably less than 0.6. Further, it is preferable that the multiradius element be disposed outboard (relative to the side of the vehicle and with the plano-multiradius reflective element assembly oriented as it would be when mounted in an exterior sideview mirror assembly on an automobile) on the plano-multiradius reflective element assembly so that the multiradius element is positioned to provide an auxiliary, wide-angle view of a “blind-spot” region in an adjacent sidelane while the more inboard-disposed plano element with unit magnification provides the principal sideview image to the driver.

Also, it is preferable that the principal axis of the rearward field of view of the multiradius element be different from and angled to the principal axis of the rearward field of view of the plano element when both are attached to the backing plate element of the plano-multiradius reflective element assembly and when the plano-multiradius reflective element assembly is mounted and operated in an exterior sideview mirror assembly on an automobile. Preferably, the principal axis of the rearward field of view of the plano element is directed generally parallel to the road that the automobile equipped with the plano-multiradius reflective element assembly is travelling on (i.e. generally parallel to the longitudinal axis of the automobile) so as to provide the driver with a long-distance view of approaching vehicles in the side lane that the plano element views). However, preferably the principal axis of the rearward field of view of the multiradius element of, for example, a door-mounted driver-side (or passenger-side) exterior sideview mirror assembly in which the plano-multiradius reflective element assembly is mounted is directed generally downwardly towards the road surface adjacent to the driver seating location and/or several feet (such as about 1 foot to about 24 feet; more preferably, about 1 foot to about 12 feet; most preferably about 1 foot to about 8 feet in distance) to its rear (in order to capture a field of view of a rear approaching vehicle that is approaching to overtake, or is about to overtake, or is overtaking the automobile equipped with the plano-multiradius reflective element assembly). Thus, preferably, the principal axis of the rearward field of view of the multiradius element is

angled and directed generally downwardly with respect to the longitudinal axis of the automobile and thus is at an angle to the principal axis of the rearward field of view of the plano element. For example, multiradius element 155 when attached to surface 173 of backing plate 160 (see FIG. 6B) would have its principal axis of rearward view as indicated by 180 as in FIG. 6B, and as such would be canted towards the road surface when mounted in an exterior sideview mirror assembly attached to the side of an automobile. By contrast, plano element 150 when attached to surface 174 of backing plate 160 (see FIG. 6A) would have a principal axis as indicated by 185 as in FIG. 6A and, as such, would be generally parallel to the road surface when mounted in an exterior sideview mirror assembly attached to the side of an automobile. Having the multiradius element canted somewhat downwards towards the road surface assists visual detection by the driver of overtaking vehicles in the traditional “blind-spot” in the adjacent side lane. The angle that the multiradius element is angled on the backing plate element of the plano-multiradius reflective element assembly relative to the plane of the plano reflective element will vary from automobile model to model, but generally is preferred to be in the about 1° to about 10° range; about 2° to about 8° range more preferred; and about 3° to about 6° range most preferred. In order to conveniently achieve an angling of the multiradius portion with respect to the plano portion (and preferably a downward angling), the portion of the backing plate element that the multiradius reflective element is attached to can be angled relative to the adjacent portion of the backing plate element that the plano reflective portion is attached to. Thus, and referring to FIG. 6, plano-multiradius reflective element assembly 130 includes a molded polymeric backing plate element 160 comprising a generally flat portion 162 (between BB and CC in FIG. 6) and an adjacent curved portion 161 (between AA and BB). As indicated by 190 and 195, portion AA to BB of backing plate element 160 is generally angled to portion BB to CC of backing plate 160. Preferably, the portion of backing plate element 160 to which the auxiliary reflective element attaches is angled towards the front (compared to the angling of plano reflective element) of an automobile equipped with the plano-auxiliary reflective element assembly of the present invention. FIG. 6 is a view of plano-multiradius reflective element assembly 130 as it would appear from above the vehicle as it would be orientated in use (with portion 162 closer to the driver than portion 161). The wall section, section XX in FIG. 6, taken through section 162 of backing plate element 160 is of substantially constant dimension (as illustrated in FIG. 6A) whereas the wall section, section YY in FIG. 6B, taken

through section 161 of backing plate element 160 is of varying dimension and is angled. Plano reflective element 150 and multiradius reflective element 155 (for example, plano element 150 can comprise an electrochromic mirror element and multiradius element 155 can comprise a chrome coated glass reflector) are attached to portions 162 and 161, respectively.

5 By being supported on the angled face 173 (see FIG. 6B) of portion 161, the principal viewing axis of multiradius reflector element 155 is angled downwards towards the road surface, as compared to the more horizontal-viewing principal viewing axis of plano element 150, when plano-multiradius reflective element 130 is mounted in an exterior sideview mirror assembly on an automobile. Demarcation element 165 is preferably molded in the same

10 molding tool as is used to mold backing plate element 160, and so demarcation element 165 is formed as an integral part of backing plate element 160, forming a wall thereof that partitions the surface of backing plate element 160 into a region for receiving the plano reflective element 150 and a region for receiving the auxiliary reflective element 155. Also, end-caps 170 and 171 are optionally provided. Plano reflective element 150 can attach into

15 the cavity formed between demarcation element 165 and end-cap 171; multiradius reflective element 155 can attach into the cavity formed between demarcation element 165 and end-cap 170. Note that the portion of the backing plate element where the wide-angle optic multiradius element attaches can have a thicker wall thickness than that of the portion of the backing plate element where the unit magnification optic element attaches in order to allow

20 for the angling of the multiradius element downwardly relative to the angle of the plano element, as illustrated in FIGS. 6A-B. As illustrated in FIGS. 6A-B, the angle downwards to the longitudinal axis of the vehicle of the multiradius element can generally be set by an angling of a surface of the backing plate element in order to ensure that the principal axis of the rearward field of view of the plano element is directed generally parallel to the

25 longitudinal axis of an automobile equipped with the plano-multiradius reflective element assembly and that the principal axis of the rearward field of view of the multiradius element is directed generally at an angle downwards to the longitudinal axis of the automobile.

Note that the provision of the plano-multiradius reflective element assembly of this invention as a unitary module has manufacturing advantages, particularly for exterior

30 sideview mirror assembly manufacturers who can procure a plano-multiradius reflective element assembly module from a mirror reflector supplier and then mount the plano-multiradius reflective element assembly module onto an actuator.

Referring to FIG. 7, a third embodiment 230 of a plano-multiradius reflective element assembly is illustrated. Plano-multiradius reflective element assembly 230 includes a plano reflective element 250 and a separate multiradius reflective element assembly 255, both individually attached to a backing plate element, and with demarcation element 265
5 disposed at their joint. Plano-multiradius reflective element assembly 230 is about 8.5 inches wide and about 4.25 inches tall (aspect ratio of 0.5), at their largest dimension. Shown as the shaded triangle 240 in plano reflective element 250 is the image of a triangular target object set about 35 feet rearward and of width about 8 feet and of height of about 4.1 feet as would be seen were plano-multiradius reflective element assembly 230 mounted in a driver-side
10 exterior sideview mirror assembly in an automobile such as a sports utility vehicle. In general, it is desirable that the plano reflective element be dimensioned and configured so as to have its rearward field of view capture an image (that is visible, by reflection in the plano reflective element, to a driver seated in the driver's seat in an automobile to which is attached an exterior sideview mirror assembly equipped with the plano-auxiliary reflective element
15 assembly according to this present invention) of a triangular shaped target located about 35 feet rearward of the driver seating location, extending about 8 feet out from the plane defined by the side of the automobile and reaching a height of between about 4 feet and about 5 feet from the road surface at that location 35 feet rearward of the automobile. The total field of view rearwardly of the vehicle of plano-multiradius reflective element assembly 230 (which
20 is a combination of the field of view of plano reflective element 250 and of the auxiliary multiradius reflective element 255) preferably generally subtends an angle of at least about 30° (and more preferably, generally subtends an angle of at least about 35° and most preferably, generally subtends an angle of at least about 40°) with respect to the side of an automobile to which is attached an exterior sideview mirror assembly equipped with plano-
25 multiradius reflective element assembly 230.

Referring to FIG. 8, another embodiment 310 of the plano-auxiliary reflective element assembly of the present invention is illustrated. Plano-auxiliary reflective element assembly 310 includes a first reflective element 312 and a second or auxiliary, separate reflective element 314 which are together supported in a frame element assembly 316. As
30 will be more fully described below, frame element assembly 316 is adapted such that when reflective elements 312 and 314 are placed, or otherwise positioned, in frame element assembly 316, the angular orientation of each reflective element is pre-established such that

during assembly, the assembler need simply place the reflective elements in frame element assembly 316.

In the illustrated embodiment, frame element assembly 316 includes a frame 318 with a forward facing open portion 318a (FIG. 9) (and thus when frame element
5 assembly 316 is mounted in a vehicle-mounted exterior sideview mirror assembly, the forward facing open portion (318a) is facing to the front of the vehicle) through which a reflective element subassembly 317a, which includes reflective element 312, is positioned in frame element assembly 316 and a rearward facing open portion 318b (FIG. 8) (which faces
10 the rear of the vehicle when frame element assembly 316 is mounted in a vehicle mounted exterior sideview mirror assembly) in which a second reflective element subassembly 317b, which includes reflective element 314, is positioned in frame element assembly 316. Frame 318 preferably comprises a molded member formed from a plastic material, such as a reinforced nylon.

In preferred form, first reflective element 312 comprises a plano reflective
15 element 350, such as a flat reflector coated glass substrate, with a reflective surface through which the angular height and width of an image of an object is equal to the angular height and width of the object when viewed to the same distance (except for flaws that do not exceed normal manufacturing tolerances) so as to have a unit magnification. Similar to the previous embodiment, plano reflective element 350 may comprise a conventional fixed
20 reflectance reflective element or may comprise a variable reflectance reflective element who's reflectivity is electrically adjustable, as is known in the art. For example, plano reflective element 350 may comprise a flat glass substrate coated with metallic reflector coating, such as a chromium coating, titanium coating, rhodium coating, metal alloy coating, nickel alloy coating, silver coating, aluminum coating, or any alloy or composition of these
25 metal reflectors. For further details of plano reflective element 350, reference is made to the previous embodiments.

In the illustrated embodiment, reflective element 312 comprises an electrochromic reflective element and includes a first substrate 312a and a second substrate 312b with an electrochromic medium 312c disposed between first and second substrates
30 312a, 312b. Such suitable electrochromic media include, for example, a solid polymer matrix electrochromic medium as noted in reference to the previous embodiments. Electrical connectors 320a and 320b are coupled to the electrochromic medium 312c to provide a

potential across the electrochromic medium which induces the electrochromic medium to darken, as is known in the art. In the illustrated embodiment, reflective element subassembly 317a also includes an optional heater pad 322, which is disposed behind reflective element 312, and a vibration reducing element, such as a foam pad 326, positioned behind heater pad 322, which absorbs vibration of reflective element 312.

Referring again to FIG. 9, frame 318 is adapted to receive and support reflective element subassembly 317a, which is mounted to frame 318 by a backing plate 324, such as a plastic backing plate. In the illustrated embodiment, backing plate 324 mounts to the inner perimeter portion of frame 318 using conventional techniques, such as by adhesive bonding, heatstaking, snap-fit coupling, welding, or the like, to form part of frame element assembly 316. Alternatively, backing plate 324 may mount onto foam pad 326, for example, by an adhesive attachment, such as double sided sticky tape. In which case, reflective element 312 may be mounted to an inner surface of frame 318, such as by an adhesive attachment, including for example a silicone adhesive, with heater pad 322 mounted to reflective element 312, such as by an adhesive attachment, and foam pad 326 mounted to heater pad 322, such as by an adhesive attachment including, for example, double-sided sticky tape.

Frame element assembly 316 mounts reflective element assembly 310 in the mirror casing and preferably on an actuator, such as an electric actuator, which permits adjustment to the orientation of reflective element assembly 310 about one or more axis. Examples of suitable actuators are described in U.S. Pat. Nos. 5,900,999; 5,986,364; 6,132,052; 6,037,689; and 6,094,027 and copending applications Ser. No. 09/277,632, filed Mar. 26, 1999, and Ser. No. 09/408,867, filed Sept. 29, 1999, which are incorporated herein by reference in their entireties. Optionally and preferably, backing plate 324 is adapted to engage or be engaged by the actuator for repositioning of plano-auxiliary reflective element assembly 310 about one or more axes. In this manner, the orientation of both reflective element 312 and reflective element 314 are simultaneously adjusted by the actuator. As best seen in FIG. 9, forward facing side 324a of backing plate 324 includes mounting structures 324b which are engaged by the actuator to thereby mount reflective element assembly 310 in the mirror casing.

Referring again to FIG. 8, frame 318 is a unitary frame and includes a first bezel portion 330 which extends around reflective element 312 and a second bezel portion

332 which extends around reflective element 314 to provide styling utility as well as functional utility. In this manner, a portion of forward facing side of frame 318 forms a support surface for reflective element 312, while a portion of rearward facing side of frame 318 forms first bezel portion 330. Similarly, another portion of the rearward facing side of frame provides support for reflective element 314 and also provides bezel portion 332. In addition, a portion of frame 318 forms a demarcation element at the juncture of reflective elements 312 and 314. In the illustrated embodiment, the demarcation element is formed by a section or portion of bezel portion 330, which will be described in greater detail in reference to bezel portion 330. Thus, frame element assembly 316 provides a support function, a positioning function, including an angling function, while also serving to provide styling utility and a demarcation function.

Second reflective element 314 comprises a radiused reflective element and, more preferably, a multiradiused reflective element 355 having a multiradiused curvature. For example, the radii of curvature of reflective element 314 may range from about 4000 mm to about 100 mm and, preferably, range from about 3000 mm to about 150 mm, and, most preferably, range from about 2000 mm to about 200 mm. In addition, reflective element 314 may comprise a fixed reflectance reflective element or may comprise a variable reflectance reflective element whose reflectivity is electrically adjustable. Preferably, reflective elements 312 and 314 include glass substrates, with at least the outer surface of each reflective element comprising glass. However, metalized plastic reflectors may also be used which is especially suitable for reflective element 314. In which case, the reflective element (314) would be especially suitable for molding in or along with frame 318, with the preformed metalized substrate forming reflective element 314 being placed into the mold forming frame 318. For further details of other suitable reflective elements, reference is made to the previous embodiments. In addition to reflective element 314, reflective element subassembly 317b includes a vibration reducing element, such as a foam pad 314a, which is positioned behind reflective element 314. Similar to reflective element 312, foam pad 314a is attached to reflective element 314 by an adhesive attachment, such as a double-sided sticky tape and, similarly, is attached to frame 318 as will be more fully described below.

As noted above, frame 318 includes a first bezel portion 330 and a second bezel portion 332. In addition, frame 318 includes an auxiliary support element 320 that provides a mounting surface or support surface for reflective element subassembly 317b. As

best seen in FIGS. 9 and 10, support element 320 includes a recessed support surface 328 which is angled to provide an angled support surface for reflective element subassembly 317b. Thus, when reflective subassembly 317b is positioned on and mounted on support surface 328, such as by an adhesive attachment between foam pad 314a and support surface 328, the orientation of reflective element 314 is established by the angle of the support surface. Optionally, support element 320 includes gussets 321a and 321b which project forwardly from the forward facing side of frame 318 to thereby reinforce support surface 328.

Referring to FIG. 8, first bezel portion 330 includes an upper portion 330a, two side portions 330b and 330c, and a lower portion 330d. Side portion 330b forms an acute angle with respect to the lower portion 330d and an obtuse angle with respect to upper portion 330a and together with upper portion 330a, side portion 330c, and lower portion 330d form a perimeter around reflective element 312 to thereby form a styling feature. Second bezel portion 332 extends outwardly from upper portion 330a and downwardly to lower portion 330d of first perimeter portion 330 and together with side portion 330b forms a perimeter around second reflective element 314. Support element 320 extends behind and between side portion 330b and second bezel portion 332 so that reflective element 314 is recessed behind side portion 330b and bezel portion 332.

As best seen in FIG. 10, upper portion 330a, side portions 330b and 330c, and lower portion 330d are substantially coplanar and together define an outer surface below which reflective element 312 is recessed when reflective element 312 is mounted in frame 318. In contrast, perimeter portion 332 is angled forwardly with respect to the plane in which upper portion 330a, side portions 330b and 330c, and lower portion 330d lie. It should be understood that the terms “forwardly”, “rearwardly” and “downwardly”, are used in reference to when the mirror system is mounted in an automobile. Therefore, “forwardly” is a direction heading toward the front of the automobile, “rearwardly” is a direction heading to the rear of the automobile, “outwardly” is a direction away from the side of the vehicle on which the mirror assembly is mounted, and “downwardly” is a direction heading toward the surface on which the vehicle is positioned (such as a ground or road surface). Similarly as noted above, reflective element 314 is recessed below an outer surface of perimeter portion 332 and also below the outer surface of side portion 330b when mounted in frame 318.

As would be understood from FIGS. 9-11, support surface 328 is also angled forwardly with respect to back plate 324 and/or reflective element 312 when frame element

assembly 316 is mounted in an automobile mounted exterior sideview mirror system. In addition, support surface 328 is also angled or tilted downwardly with respect to reflective element 312 and/or backing plate 324 such that when reflective element 314 is supported on support surface 328, reflective element 314 provides an increased field of view extending
5 laterally or outwardly from the longitudinal axis of the automobile and also downwardly of the longitudinal axis of the automobile.

Referring to FIGS. 13 and 14, support surface 328 is configured such that reflective element 314 is tilted forwardly at an angle α with respect to the X-axis of reflective element 312. In one form, angle α is in a range of about 0.75° to about 5° . In another form,
10 angle α is in a range of about 1° to about 3° . In yet another form, angle α is in a range of about 1.25° to about 2.5° . Reflective element 314 is also tilted downwardly with respect to the Y-axis of reflective element 312 at an angle β . In one form, angle β is in a range of about 0.75° to about 5° . In another form, angle β is in a range of about 1.5° to about 3.5° . In yet another form, angle β is in a range of about 2° to about 3° . With the tilted orientation of
15 reflective element 314, reflective element 314 provides a field of view with a principal axis that sweeps outwardly and downwardly with respect to the principal axis of the field of view of reflective element 312.

In the illustrated embodiment, support surface 328 is provided by a plate member 321. Plate member 321 may comprise a solid plate member or a foraminous plate
20 member. In the illustrated embodiment, plate member 321 is integrally formed with perimeter portions 330 and 332 during the molding process of frame 318. As previously noted, frame 318 includes a rearwardly facing opening 318b through which reflective element 314 is inserted for placement on support surface 328. For example, reflective element 314 may be positioned in frame 318 on support surface 328 during the molding
25 process of frame 318, such as by insert molding, or may be inserted into frame 318 before the plastic material forming frame 318 is fully cured and is still pliable. In which case, reflective element subassembly 317b is mounted to auxiliary support 320 by an adhesive attachment or a mechanical attachment. Alternatively, support surface 328 may be formed by peripheral flange or a frame. In this manner, reflective element subassembly 317b may be placed in
30 frame 318 from its forward facing side.

Referring to FIG. 14, when reflective element assembly 310 is mounted in a vehicle reflective element 312 has a field of view 360 which forms an angle A with respect to

the longitudinal center line of the vehicle in a range of about 8° to about 20°. In another form, angle A is in a range of about 10° to about 18°. In yet another form, angle A is in a range of about 12° to about 16°. Similarly, reflective element 314 has a field of view 362 which forms an angle C in range of about 15° to about 50°. In another form, angle C is in a range of about 15° to about 35°. In yet another form, angle C is in a range of about 15° to about 25°. Consequently, the overall field of view of reflective elements 312 and 314 extends over an angle B, which ranges from about 8° to about 50° in one form, about 10° to about 35° in another form, and about 12° to about 25° in yet another form. Furthermore, field of views 360 and 362 overlap over a range having angle D in a range of about 20° to about 2°, or in a range of about 15° to about 5°. In another form, angle D is in a range of about 10° to about 8°.

From the foregoing, it can be appreciated that reflective elements 312 and 314 provide a wider field of view than a wholly planar rearview mirror element that fully accommodates an equivalent frame having similar dimensions. In addition, because reflective elements 312 and 314 have overlapping field of views, an image in the field of view of reflective element 314 will transition or move between the reflective elements and appear in both reflective elements during the transition to thereby enable the driver of the automobile to view or be conscious of the object continuously. In the illustrated embodiment, reflective element 314 is positioned in an outboard position relative to reflective element 312; therefore, when a vehicle or object that is approaching the automobile from the rear and to some extent from the side, the image of the approaching object will first appear in reflective element 312, then appear in both reflective elements 314 and 312, and then move to reflective element 314 so that the driver will be initially aware of the approaching object when its image first appears in reflective element 312 and continue to be aware of the object as it moves closer to the automobile, thus increasing the range of viewing of the driver. Since the image transitions smoothly from reflective element 312 to reflective element 314, the driver's awareness of the object is continuous and, further, the driver is not distracted from sudden transitions that often occur with conventional spotter mirrors. Typically, when an object "falls" or "drops" out, a driver's consciousness of the object reduces significantly, if not ceases, which is one of the causes of many automobile blind spot accidents. Hence, when combined with the field of view of an interior rearview mirror system, the present invention reduces, if not eliminates, an automobile's blind spot. For

further discussion of blind spots in vehicle rearview mirror systems, reference is made to copending U.S. provisional application entitled VEHICULAR REARVIEW MIRROR SYSTEM, filed November 20, 2000 by Robert E. Schnell, David K. Willmore, and Richard J. Weber (Attorney Docket DON01 P-840), which is herein incorporated by reference in its entirety. Thus, the plano-auxiliary reflective element assembly provides a seamless rearvision function whereby the image of a side approaching/side overtaking other vehicle is substantially seamlessly maintained as the image of the overtaking or approaching vehicle transitions from being principally and substantially viewed by the driver of the vehicle (the vehicle mounted with the mirror system of the present invention) in the plano reflective element to be seen in the auxiliary reflective element.

Referring to FIG. 15, the numeral 410 generally designates yet another embodiment of an automobile exterior sideview mirror system of the present invention. Exterior sideview mirror system 410 includes a housing 412, a first reflective element 414, and a second or auxiliary, separate reflective element 416, which together provide an increase field of view over conventional planar reflectors mounted in a frame of equivalent dimensions to the combined lateral dimensions of reflective element 414 and 416.

Housing 412 includes a mirror casing 417 and a sail 418, which mounts casing 412 to a side of an automobile. Though illustrated as a fixed mounting arrangement, it should be understood that mirror system 410, like the previous embodiments, may comprise a break-away mirror system or a powerfold mirror system.

In the illustrated embodiment, reflective element 414 comprises a plano reflective element having a unit magnification, similar to the plano reflective elements described in reference to the previous embodiments. Reflective element 416 preferably comprises a wide-angle reflector, such as a convex or aspheric reflector, and may include a multiradiused curvature. For further description of suitable reflectors, reference is made to the previous embodiment.

In the illustrated embodiment, reflective element 416 is mounted in an outboard position relative to reflective element 414 and is fixedly mounted to bezel 420 of mirror casing 417. In addition, reflective element 416 is preferably angled downwardly and forwardly relative to first reflective element 414 when mirror system 410 is mounted to an automobile to thereby increase the field of view of mirror system 410. Optionally and preferably, reflective element 416 is detachably mounted to bezel 420, such as by mechanical

fasteners, including clips, so that reflective element 416 can be removed, such as for replacement.

Reflective element 414 preferably comprises an independently positionable reflective element and is mounted by a backing member, such as a backing plate, to an actuator, which provides multi-axis positioning of reflective element 414. In this manner, reflective element 414 and reflective element 416 are separately and independently mounted in housing 412. In addition, reflective element 414 optionally extends behind reflective element 416 in order to maintain the overlap of the field of views of reflective elements 414 and 416 even when reflective element 414 is moved by the actuator. Similar to the previous embodiment, when an object moves toward the automobile, in which mirror system 410 is mounted, from the rear of the automobile or laterally with respect to the automobile, the image of the object will appear initially in reflective element 414. As the object moves closer to the automobile, the image of the object will move from reflective element 414 to reflective element 416 such that when the image transitions between reflective element 414 and reflective element 416, the image will appear in both reflective elements.

Also, although it is preferable to utilize a multiradius or compound curvature reflective element, such as an aspherical element or a compound curvature element, for the second or auxiliary mirror element adjacent the plano or first reflective element (as this enables least discontinuity in image at the joint between the adjacent elements of the assembly), a spherical reflective element (that has substantially only one radius of curvature and, as such, is a section from a sphere) can optionally be used adjacent the plano reflective element instead of, or in addition to, the multiradius reflective element. Also, a plano auxiliary mirror such as a flat mirrored substrate can be used, less preferably, as a substitute for a multiradius reflective element in those embodiments where the auxiliary reflective element is angled relative to the plane of the principal, plano reflective element so as to view a blind spot region of the principal plano element. Also, the plano-multiradius reflective element assembly can optionally be fixedly attached to an exterior sideview mirror assembly housing that is not movable, or, alternately, the exterior sideview mirror assembly housing to which the plano-multiradius reflective element assembly is fixedly attached can itself be actuated to move, such as by motor action, so that by moving the exterior sideview mirror assembly housing, the field of rearward view of the plano-multiradius reflective element

assembly fixedly attached thereto can correspondingly move and be repositioned to suit the field of view need of a particular driver seated in the automobile cabin.

The above description is considered that of the preferred embodiments only. Modification of the invention will occur to those skilled in the art and to those who make or
5 use the invention. Therefore, it is understood that the embodiments shown in the drawings and described above are merely for illustrative purposes and are not intended to limit the scope of the invention, which is defined in the following claims as interpreted according to the principles of patent law, including the doctrine of equivalents.

We claim:

1. An exterior sideview mirror system suitable for use in an automobile, said exterior sideview mirror system comprising:

an exterior sideview mirror assembly adapted for attachment to a side of an automobile;

5 said exterior sideview mirror assembly including a reflective element assembly having a rearward field of view when attached to said side of the automobile;

wherein said reflective element assembly comprises a plano reflective element having unit magnification and a separate multiradius reflective element having a multiradius curvature; and

10 said reflective element assembly further including a frame element assembly, said plano reflective element and said multiradius reflective element of said plano-multiradius reflective element assembly being mounted to said frame element assembly, said frame element assembly mounting to an actuator and movable by said actuator in order to position said rearward field of view, and said frame element assembly being adapted to orient
15 said multiradius reflective element such that said multiradius reflective element has a viewing range which fans outwardly and downwardly with respect to a viewing range of said plano reflective element to thereby provide an increased field of view for said exterior sideview mirror assembly.

2. The exterior sideview mirror system of Claim 1, wherein said plano reflective element and said multiradius reflective element are adjacently attached to said frame element assembly at a joint, and wherein said reflective element assembly includes a demarcation element, said demarcation element disposed at said joint to form a demarcation between said
5 plano reflective element and said multiradius reflective element, said demarcation element having a portion visible to a driver of the automobile.

3. The exterior sideview mirror system of Claim 2, wherein said demarcation element is dark colored.

4. The exterior sideview mirror system of Claim 3, wherein said frame element assembly includes a first bezel portion extending around said plano reflective element, said demarcation element comprising a segment of said first bezel portion.
5. The exterior sideview mirror system of Claim 4, wherein said multiradiused reflective element comprises a bent glass substrate with radii of curvature in the range of about 4000 mm to about 100 mm.
6. The exterior sideview mirror system of Claim 1, wherein said frame element assembly includes a frame, said first and second reflective elements being mounted in said frame.
7. The exterior sideview mirror system of Claim 6, wherein said multiradiused reflective element is mounted to said frame at an outboard position, and said plano reflective element is positioned adjacent said multiradiused reflective element and at an inboard position with respect to said multiradiused reflective element when said exterior sideview mirror assembly is mounted to an automobile.
8. The exterior sideview mirror system of Claim 7, wherein said plano reflective element is mounted to said frame by a backing plate.
9. The exterior sideview mirror system of Claim 8, wherein said backing plate is adapted to mount to said actuator.
10. The exterior sideview mirror system of Claim 9, wherein said actuator comprises an electrical actuator.
11. The exterior sideview mirror system of Claim 6, wherein said plano reflective element and said multiradiused reflective element are adjacently attached to said frame, said frame including a first perimeter portion and a second perimeter portion, said first perimeter portion extending around said plano reflective element, and said second perimeter portion extending around said multiradiused reflective element.

12. The exterior sideview mirror system of Claim 11, wherein a side portion of said first perimeter portion of said frame provides a demarcation between said plano reflective element and said multiradiused reflective element.
13. The exterior sideview mirror system of Claim 11, wherein said second perimeter portion is angled downwardly and forwardly with respect to said first perimeter portion when said mirror assembly is mounted to an automobile.
14. The exterior sideview mirror system of Claim 6, wherein said multiradiused reflective element is attached to said frame by at least one of an adhesive attachment and a mechanical attachment.
15. The exterior sideview mirror system of Claim 6, wherein said backing plate is attached to one side of said first reflective element and said frame by one of an adhesive attachment, a welded attachment, and a mechanical attachment.
16. The exterior sideview mirror system of Claim 15, wherein an opposed side of said frame forms a bezel around said plano reflective element.
17. The exterior sideview mirror system of Claim 1, wherein said plano reflective element includes a rearward field of view having a principal axis different from and angled to a principal axis of the rearward field of view of said multiradiused reflective element when mounted in said exterior sideview mirror assembly.
18. The exterior sideview mirror system of Claim 17, wherein said principal axis of the rearward field of view of said multiradiused reflective element is directed generally outwardly and downwardly with respect to a longitudinal axis of the automobile.
19. The exterior sideview mirror system of Claim 18, wherein said principal axis of the rearward field of said multiradiused reflective element forms a downward angle with respect to the longitudinal axis of the automobile in the range from about $.75^\circ$ to about 5° .

20. The exterior sideview mirror system of Claim 19, wherein said downward angle is in a range from about 1.5° to about 3.5°.
21. The exterior sideview mirror system of Claim 20, wherein said downward angle is in a range of about 2° to about 3°.
22. The exterior sideview mirror system of Claim 18, wherein said principal axis of said multiradiused reflective element forms an outward angle with respect to the longitudinal axis of the automobile in a range of about 0.75° to about 5°.
23. The exterior sideview mirror system of Claim 22, wherein said outward angle is in a range of about 1° to about 3°.
24. The exterior sideview mirror system of Claim 23, wherein said outward angle is in a range of about 1.25° to about 2.5°.
25. The exterior sideview mirror system of Claim 1, wherein said exterior sideview mirror assembly comprises a fixedly attached exterior sideview mirror assembly.
26. The exterior sideview mirror system of Claim 1, wherein said exterior sideview mirror assembly comprises a break-away exterior sideview mirror assembly.
27. The exterior sideview mirror system of Claim 1, wherein said exterior sideview mirror assembly comprises a powerfold exterior sideview mirror assembly.
28. The exterior sideview mirror system of Claim 1, wherein at least one of said plano reflective element and said multiradiused reflective element comprises a variable reflectance reflective element.

29. The exterior sideview mirror system of Claim 28, wherein each of said plano reflective element and said multiradiused reflective element comprises a variable reflectance reflective element.

30. The exterior sideview mirror system of Claim 1, wherein said plano reflective element comprises an electrochromic reflective element.

31. An automobile exterior sideview mirror system comprising:

an exterior sideview mirror assembly adapted for attachment to a side of an automobile;

5 said exterior sideview mirror assembly including a mirror casing, a reflective element assembly, and an actuator; and

10 said reflective element assembly including a frame element assembly, a first reflective element having unit magnification, and a second reflective element having a multiradiused curvature, said frame element assembly mounting said first reflective element and said second reflective element in said mirror casing and being adapted to mount to said actuator, said actuator adjusting the orientation of said reflective element assembly, said first reflective element having a first rearward field of view with a first principal axis, said second reflective element having a second rearward field of view with a second principal axis, and said frame element assembly angling said second principal axis outwardly and downwardly with respect to said first principal axis.

32. The exterior sideview mirror system of Claim 31, wherein said second principal axis is angled outwardly from said first principal axis at an angle in a range of about 0.75° to about 5°.

33. The exterior sideview mirror system of Claim 32, wherein said second principal axis is angled outwardly from said first principal axis at an angle in a range of about 1° to about 3°.

34. The exterior sideview mirror system of Claim 33, wherein said second principal axis is angled outwardly from said first principal axis at an angle in a range of about 1.25° to about 2.5°.

35. The exterior sideview mirror system of Claim 31, wherein said second principal axis is angled downwardly from said first principal axis at an angle in a range of approximately 0.75° to about 5°.

36. The exterior sideview mirror system of Claim 35, wherein said second principal axis is angled downwardly from said first principal axis at an angle in a range of about 1.5° to about 3.5°.

37. The exterior sideview mirror system of Claim 36, wherein said second principal axis is angled downwardly from said first principal axis at an angle in a range of about 2° to about 3°.

38. The exterior sideview mirror system of Claim 31, wherein said second principal axis is directed generally outwardly and downwardly with respect to a longitudinal axis of an automobile when said mirror assembly is mounted to the automobile.

39. The exterior sideview mirror system of Claim 31, wherein said frame element assembly includes a support surface for said second reflective element, said support surface angling said second principal axis of said second reflective element.

40. The exterior sideview mirror system of Claim 31, wherein said second reflective element is outboard of said first reflective element.

41. The exterior sideview mirror system of Claim 31, wherein frame element assembly includes a first open portion and a second open portion, said first open portion receiving said first reflective element, and said second open portion receiving said second reflective element.

42. The exterior sideview mirror system of Claim 41, wherein said second open portion comprises a rearwardly facing open portion when said mirror assembly is mounted to the automobile.

43. The exterior sideview mirror system of Claim 42, wherein said first open portion comprises a forwardly facing open portion when said mirror assembly is mounted to the automobile.

44. The exterior sideview mirror system of Claim 31, wherein at least one of said reflective elements comprises a variable reflectance reflective element.

45. The exterior sideview mirror system of Claim 31, wherein at least one of said first reflective element and said second reflective element comprises an electro-optic reflective element.

46. An automobile exterior sideview mirror system comprising:

an exterior sideview mirror assembly adapted for attachment to a side of an automobile; and

said exterior sideview mirror assembly including an actuator and a reflective element assembly, said reflective element assembly having a frame element assembly, a first reflective element, and a second reflective element, said first reflective element comprising a plano reflective element, said second reflective element comprising a multiradiused reflective element having a multiradiused curvature, said frame element assembly being adapted to mount to said actuator and including a frame and a support surface for said second reflective element, said actuator adjusting an orientation of said reflective element assembly, said support surface orienting said second reflective element downwardly and forwardly of said first reflective element when said mirror assembly is mounted to an automobile whereby said second reflective element provides a viewing range which spans outwardly and downwardly with respect to the automobile to thereby provide an increased field of view for said exterior sideview mirror assembly.

47. The exterior sideview mirror system of Claim 46, wherein said frame forms a bezel portion around said first reflective element.
48. The exterior sideview mirror system of Claim 47, wherein said frame forms a bezel portion around said second reflective element.
49. The exterior sideview mirror system of Claim 46, wherein a portion of said frame forms a demarcation between said first and second reflective elements.
50. The exterior sideview mirror system of Claim 46, wherein said support surface comprises a plate element.
51. The exterior sideview mirror system of Claim 50, wherein said plate element comprises a solid plate element.
52. The exterior sideview mirror system of Claim 50, wherein said plate element comprises a foraminous plate element.
53. The exterior sideview mirror system of Claim 46, wherein said support surface comprises a frame.
54. The exterior sideview mirror system of Claim 46, wherein said frame includes a first bezel portion and a second bezel portion, said first bezel portion extending around said first reflective element, and said second bezel portion extending around said second reflective element.
55. The exterior sideview mirror system of Claim 54, wherein said second bezel portion is angled forwardly with respect to said first bezel portion when said exterior sideview mirror assembly is mounted to a side of an automobile.
56. The exterior sideview mirror system of Claim 46, wherein said first reflective has a substantially unit magnification.

57. The exterior sideview mirror system of Claim 46, wherein said frame includes a forward facing open portion and a rearward facing open portion when said mirror assembly is mounted to an automobile, said first forward facing open portion receiving said first reflective element, and said rearward facing open portion receiving said second reflective
5 element.

58. The exterior sideview mirror system of Claim 57, wherein a rearward facing side of said forward facing open portion defining a bezel around said first reflective element.

59. The exterior sideview mirror system of Claim 58, wherein said frame includes a bezel around said second reflective element at said rearward facing open portion.

EXTERIOR MIRROR PLANO-AUXILIARY REFLECTIVE ELEMENT ASSEMBLY

ABSTRACT

This invention provides a reflective element assembly suitable for use in an exterior sideview mirror assembly mounted to the side body of an automobile. The reflective element assembly includes a first reflective element and a second reflective element. The
5 second reflective element is angled downwardly and forwardly with respect to the first reflective element when the mirror assembly is mounted to a side of an automobile to provide an increased field of view. In one form, both reflective elements are commonly supported on a bezel, which is mounted to the mirror assembly casing. In another form, the reflective
10 elements are separately mounted, with the second reflective element fixedly mounted to the casing and the first reflective element movably supported in the mirror casing, for example, on an actuator.

10

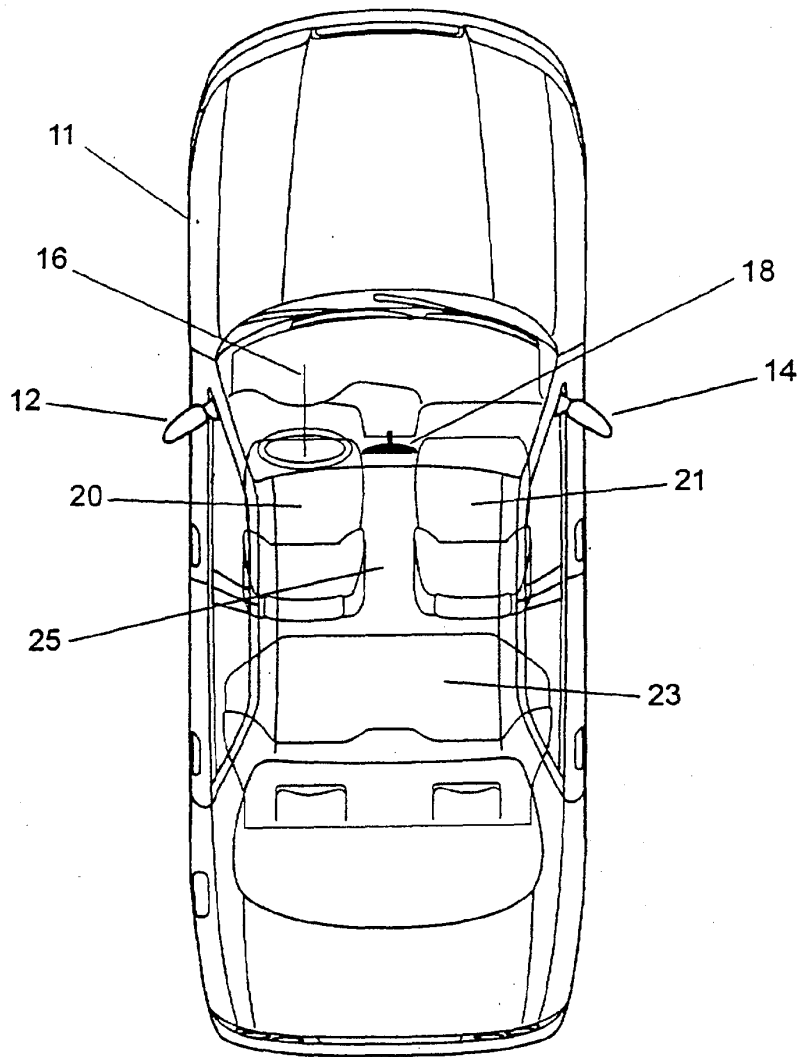

Figure 1

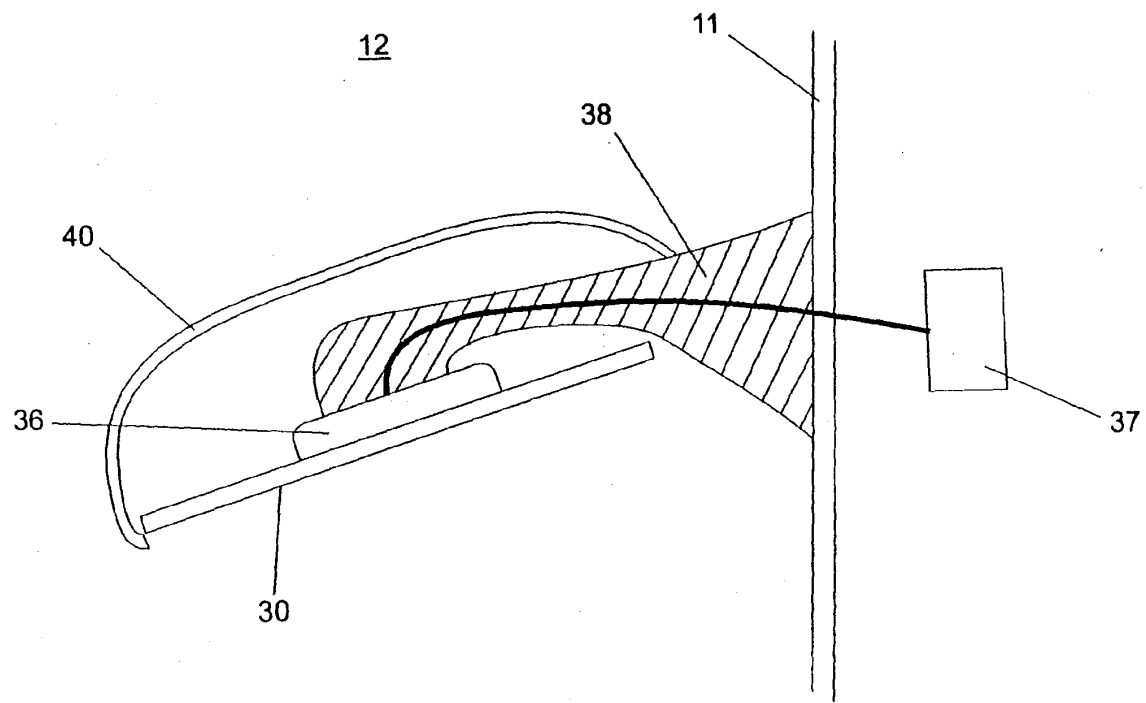

Figure 2

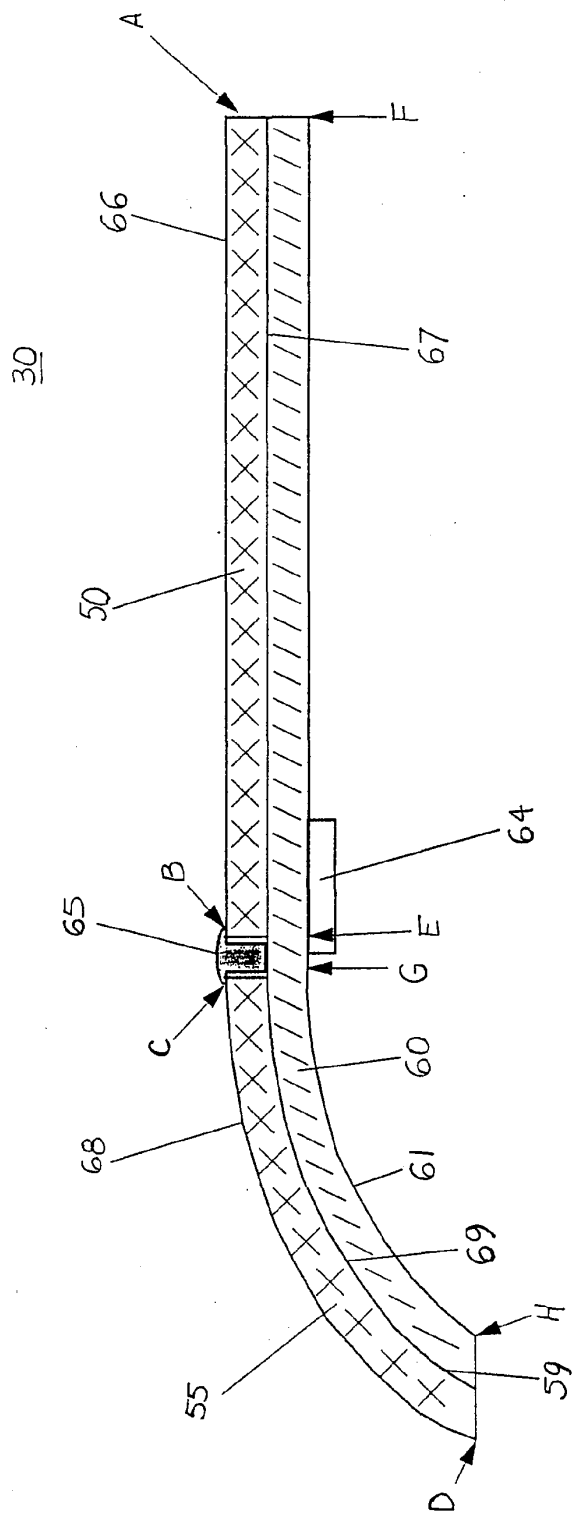

Figure 3

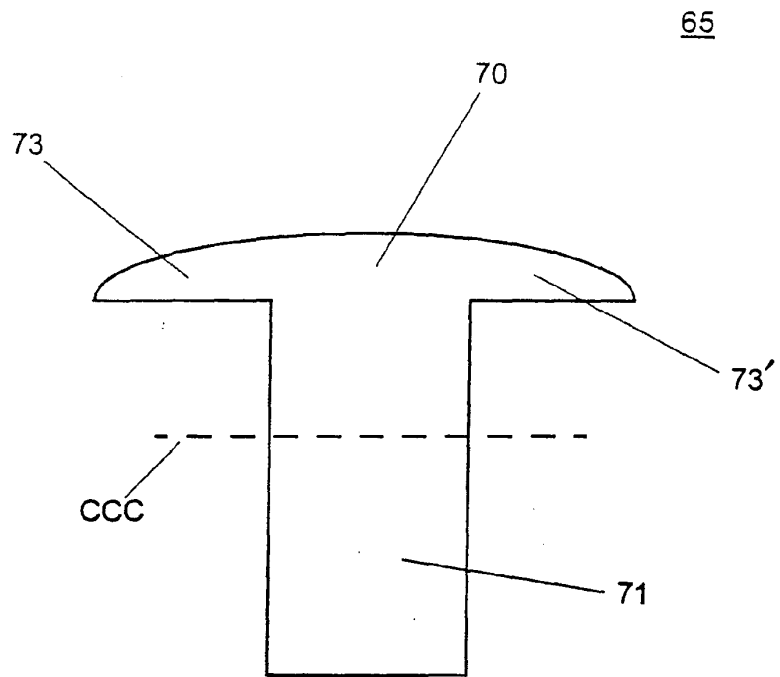
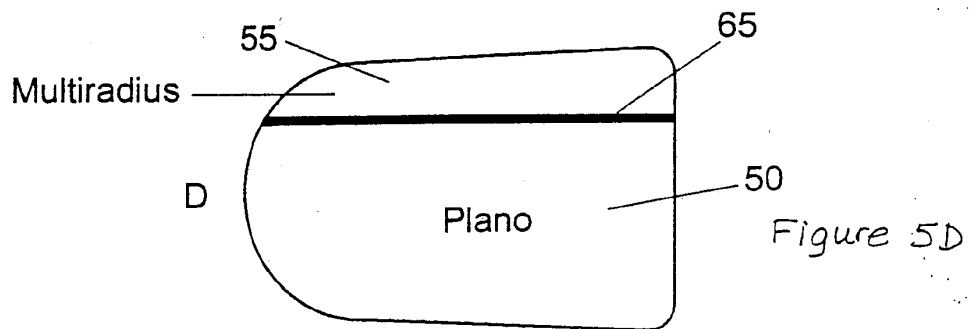
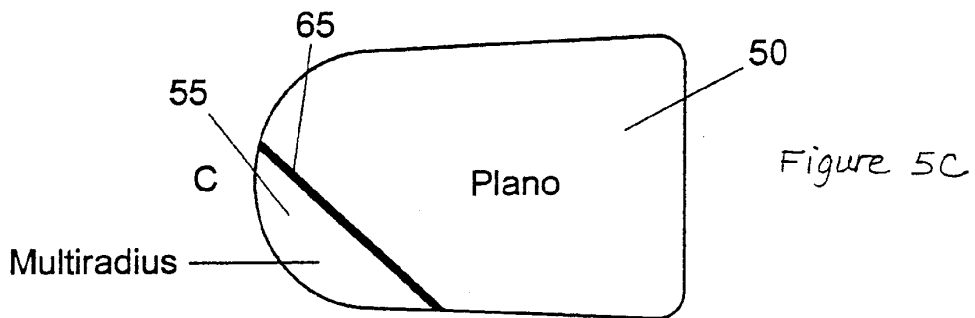
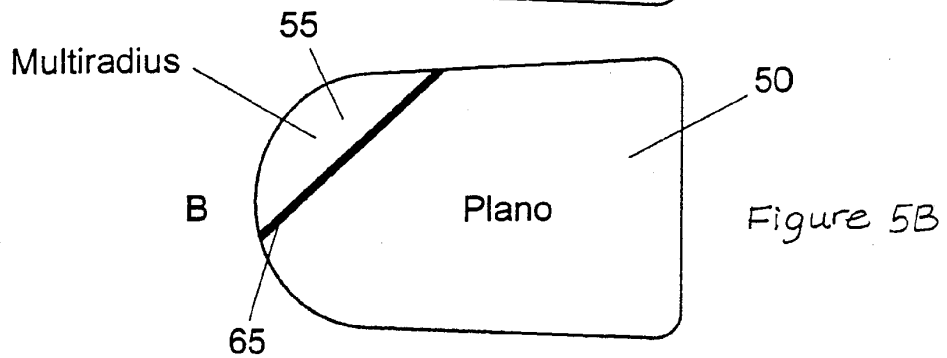
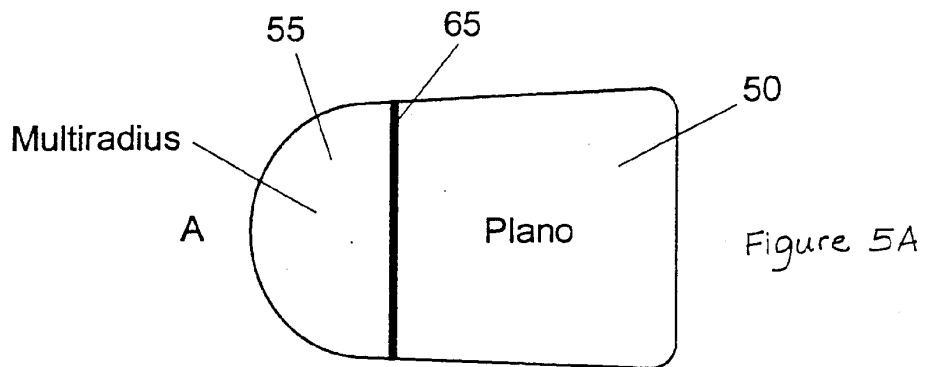
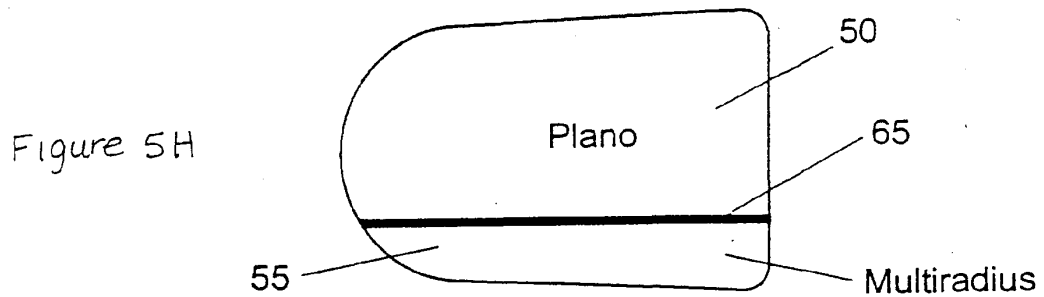
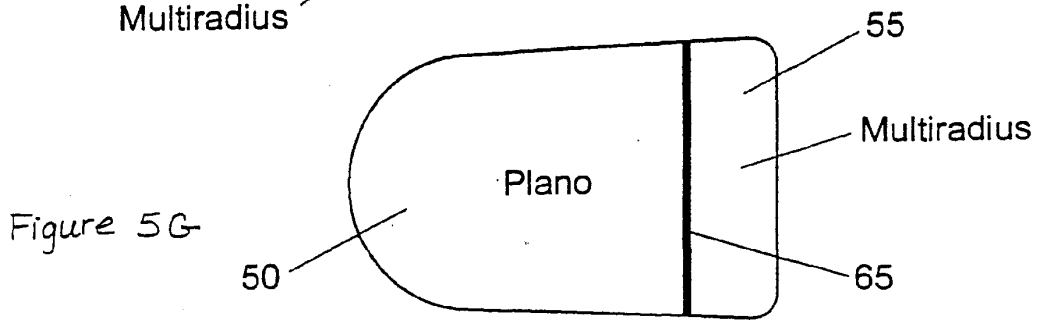
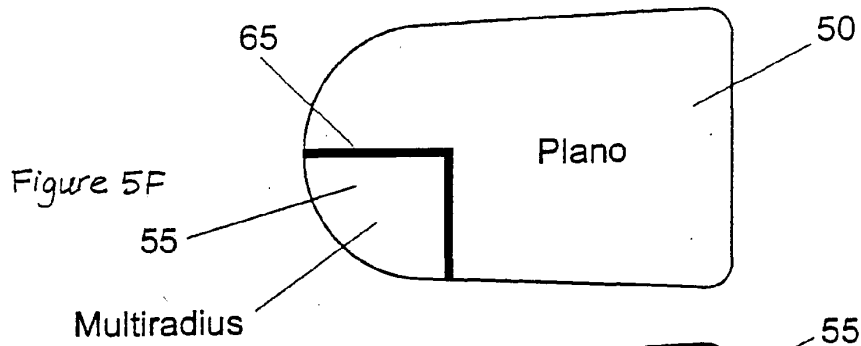
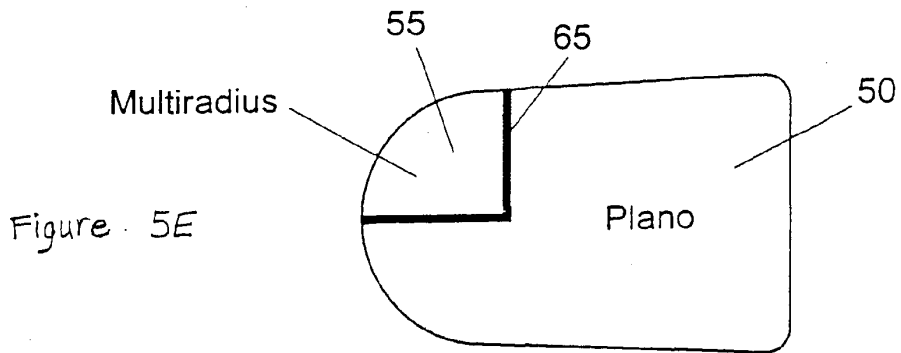

Figure 4





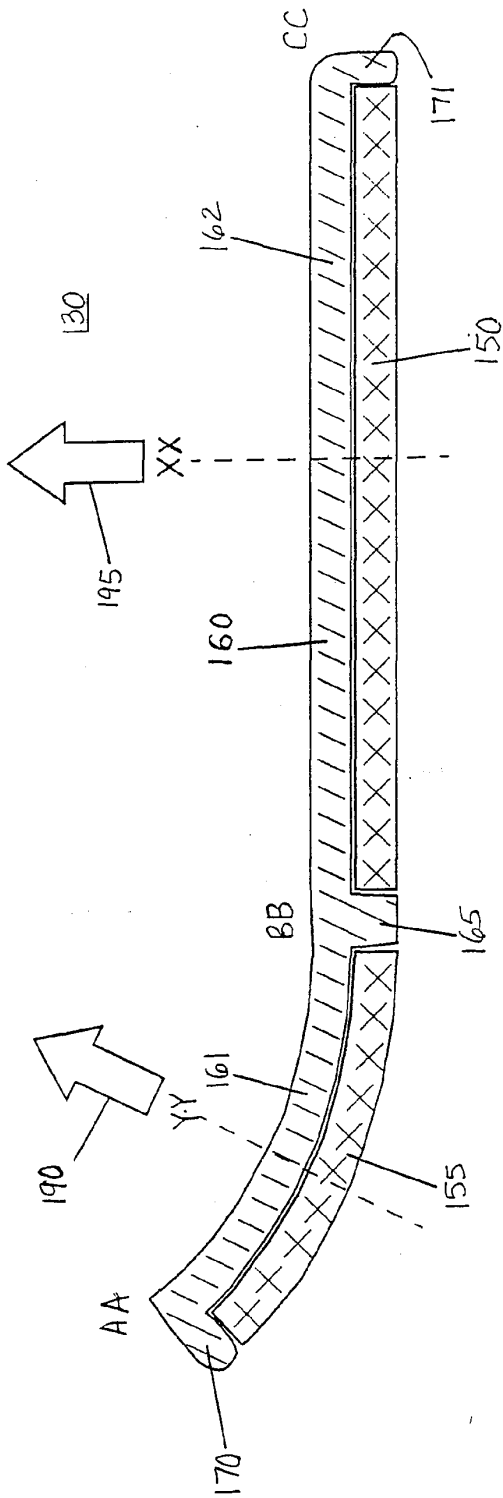

Figure 6

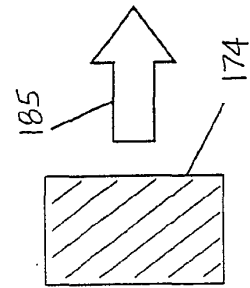

Figure 6A

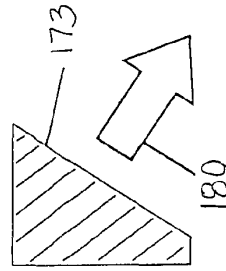

Figure 6B

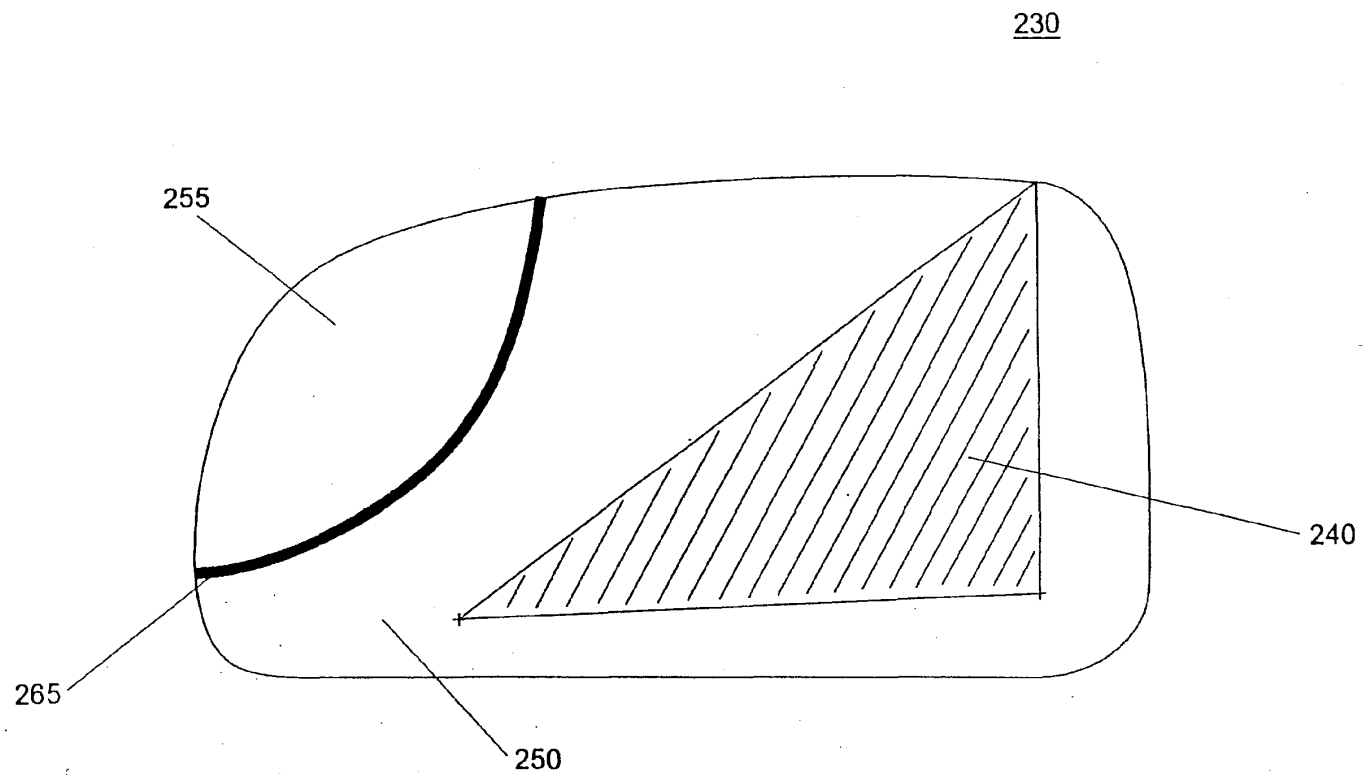

Figure 7

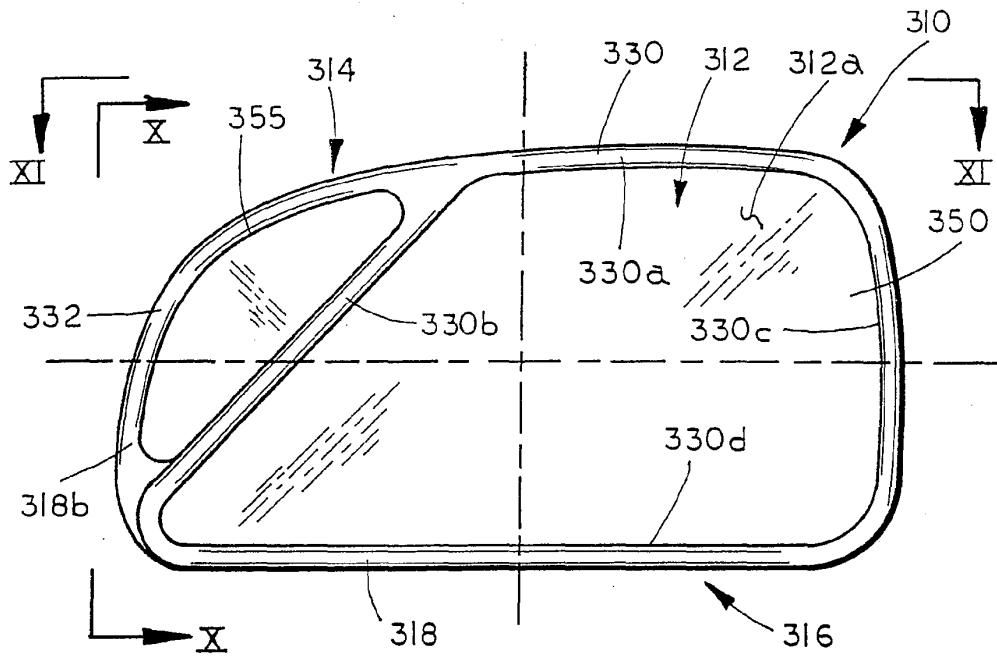

FIG. 8

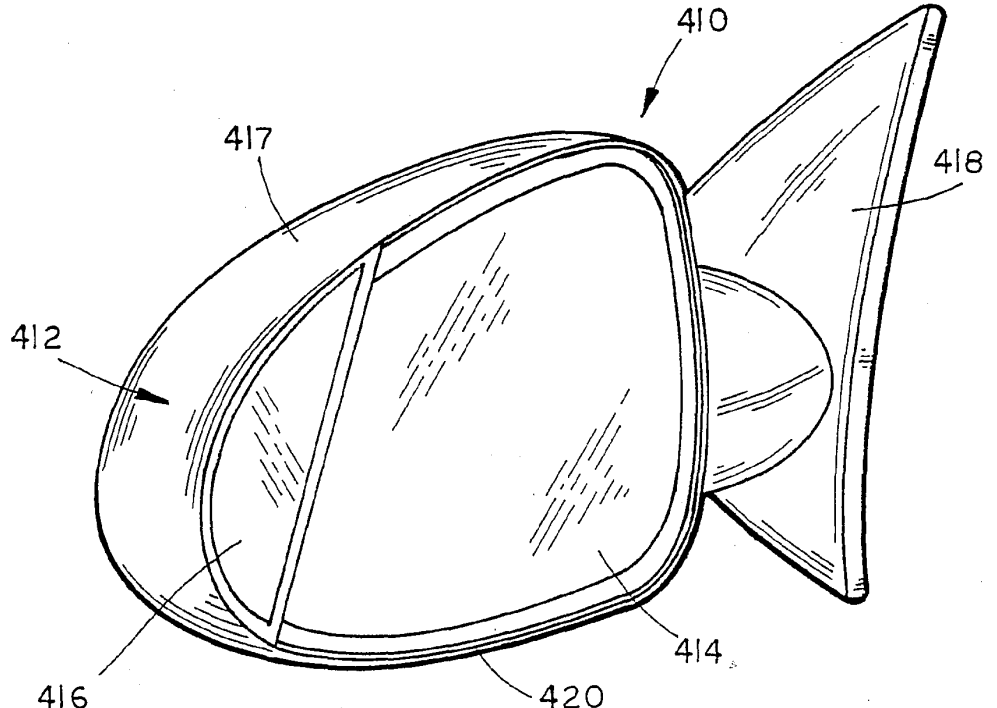

FIG. 15

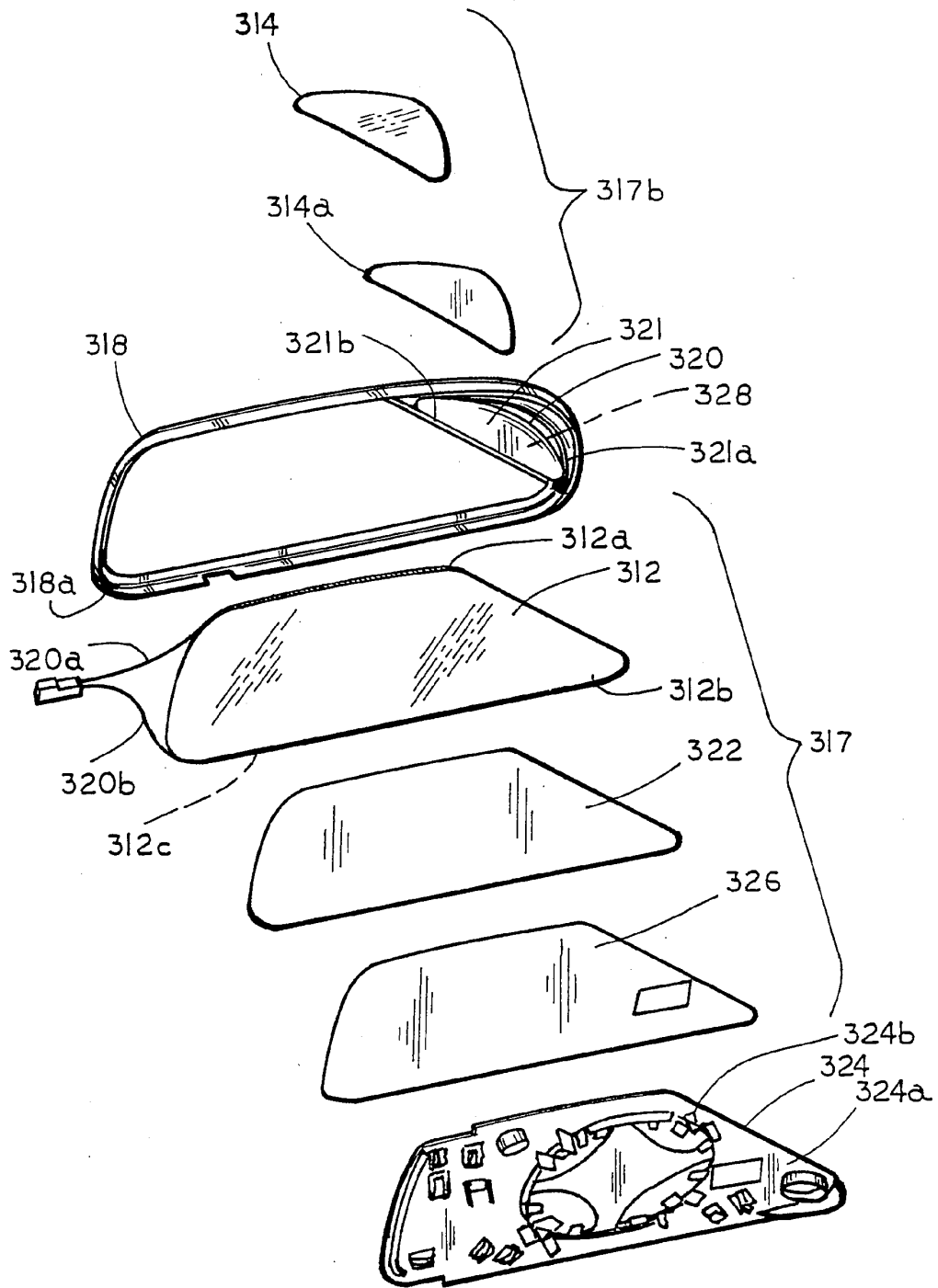

FIG. 9

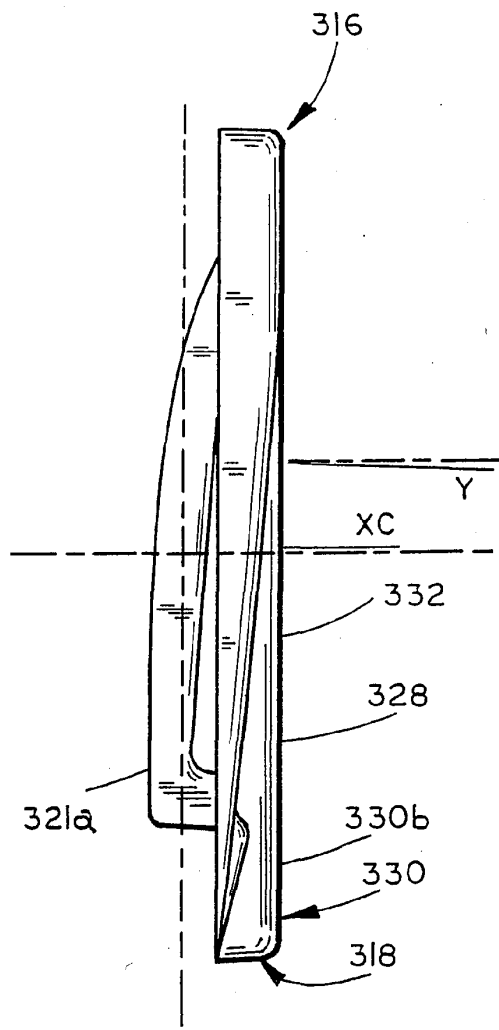

FIG. 10

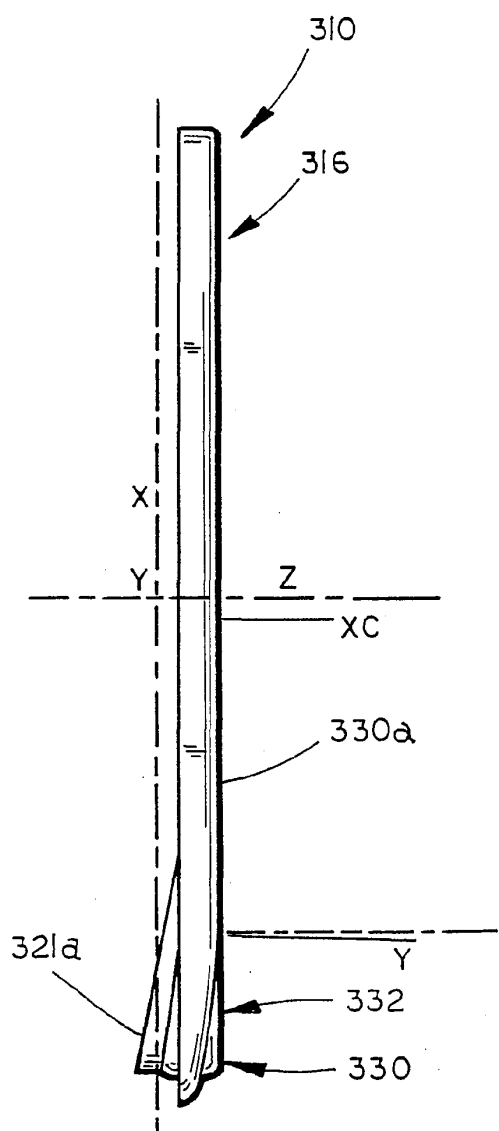
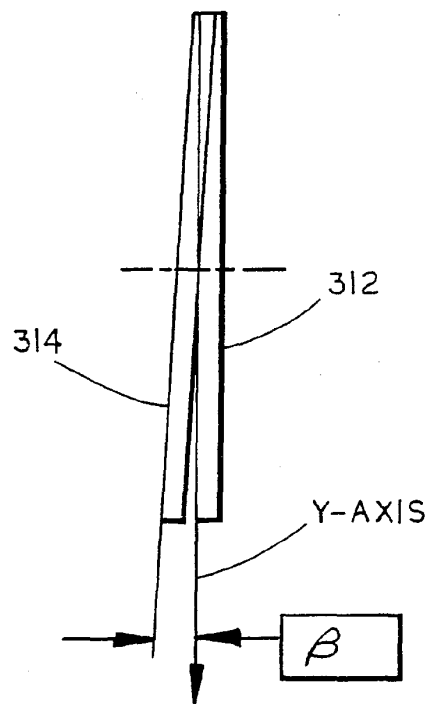
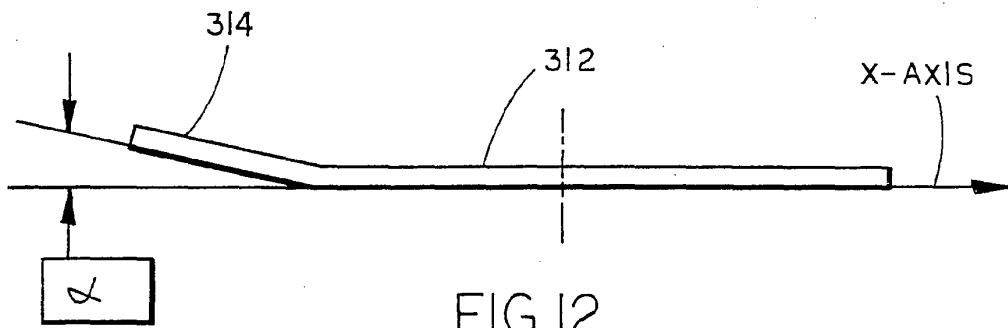

FIG. 11



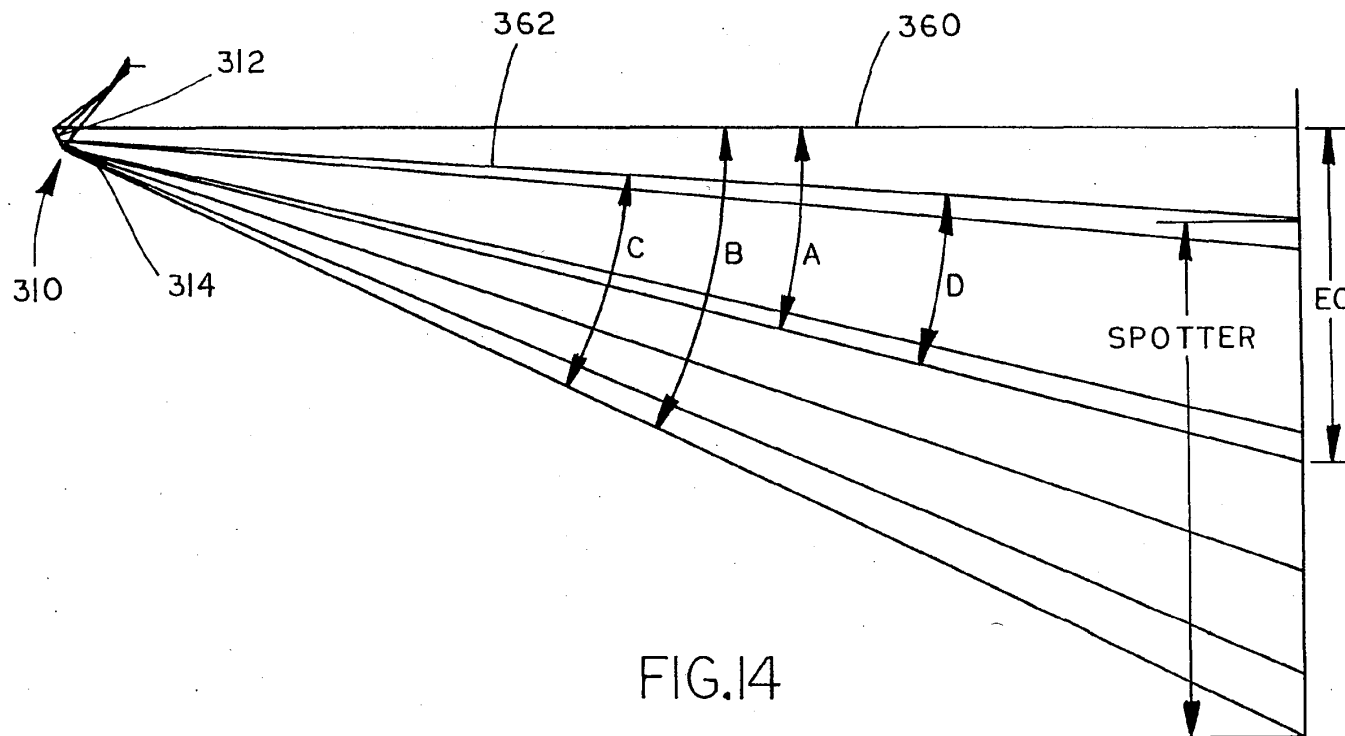

FIG.14



US006717712B2

(12) **United States Patent**
Lynam et al.

(10) **Patent No.:** **US 6,717,712 B2**
(45) **Date of Patent:** **Apr. 6, 2004**

(54) **EXTERIOR MIRROR PLANO-AUXILIARY REFLECTIVE ELEMENT ASSEMBLY**

(75) Inventors: **Niall R. Lynam**, Holland, MI (US);
John O. Lindahl, Fruitport, MI (US);
Hahns Yoachim Fuchs, Holland, MI (US)

(73) Assignee: **Donnelly Corporation**, Holland, MI (US)

(*) Notice: Subject to any disclaimer, the term of this patent is extended or adjusted under 35 U.S.C. 154(b) by 84 days.

(21) Appl. No.: **09/745,172**

(22) Filed: **Dec. 20, 2000**

(65) **Prior Publication Data**

US 2002/0072026 A1 Jun. 13, 2002

Related U.S. Application Data

(63) Continuation-in-part of application No. 09/478,315, filed on Jan. 6, 2000, now Pat. No. 6,522,451.

(51) **Int. Cl.**⁷ **G02F 1/15**; G02B 5/08; G02B 5/10; G02B 7/182; B60R 1/06

(52) **U.S. Cl.** **359/265**; 359/267; 359/841; 359/850; 359/864; 359/866; 359/868; 359/872; 359/877; 248/549; 248/900

(58) **Field of Search** 359/841, 850, 359/851, 854, 855, 864, 865, 866, 868, 872, 877, 265, 267; 248/549, 900

(56) **References Cited**

U.S. PATENT DOCUMENTS

- 3,338,655 A * 8/1967 Young
- 3,375,053 A 3/1968 Ward 350/293
- 3,389,952 A * 6/1968 Tobin, Jr.
- 4,268,120 A 5/1981 Jitsumori 350/302
- 4,449,786 A 5/1984 McCord 350/293
- 4,678,294 A * 7/1987 Van Nostrand
- 4,917,485 A * 4/1990 Baldwin, Sr.
- 5,239,405 A 8/1993 Varaprasad et al. 359/272
- 5,412,512 A * 5/1995 Zebold et al.

- 5,550,677 A 8/1996 Schofield et al. 359/604
- 5,557,467 A * 9/1996 McColgan et al.
- 5,621,577 A * 4/1997 Lang et al.
- 5,668,663 A 9/1997 Varaprasad et al. 359/608
- 5,724,187 A 3/1998 Varaprasad et al. 359/608
- 5,751,489 A 5/1998 Caskey et al. 359/603
- 5,784,211 A * 7/1998 Mingleedorff
- 5,793,542 A * 8/1998 Kondo et al.
- 5,805,367 A * 9/1998 Kanazawa
- 5,910,854 A 6/1999 Varaprasad et al. 359/273
- 6,116,743 A * 9/2000 Hoek
- 6,154,306 A 11/2000 Varaprasad et al. 359/273
- 6,511,192 B1 * 1/2003 Henion et al.
- 6,522,451 B1 * 2/2003 Lynam

FOREIGN PATENT DOCUMENTS

- DE 2409748 9/1975 B60R/1/02
- DE 3620228 * 12/1987
- DE 4026578 * 4/1992
- EP 0310261 A1 9/1988 B60R/1/08
- EP 0729864 * 9/1996
- EP 0917987 * 5/1999
- FR 2628042 9/1999 B60R/1/06
- GB 2092534 * 8/1982
- JP 1186443 7/1989 B60R/1/06

* cited by examiner

Primary Examiner—Ricky D. Shafer

(74) *Attorney, Agent, or Firm*—Van Dyke, Gardner, Linn & Burkhart, LLP

(57) **ABSTRACT**

This invention provides a reflective element assembly suitable for use in an exterior sideview mirror assembly mounted to the side body of an automobile. The reflective element assembly includes a first reflective element and a second reflective element. The second reflective element is angled downwardly and forwardly with respect to the first reflective element when the mirror assembly is mounted to a side of an automobile to provide an increased field of view. In one form, both reflective elements are commonly supported on a bezel, which is mounted to the mirror assembly casing. In another form, the reflective elements are separately mounted, with the second reflective element fixedly mounted to the casing and the first reflective element movably supported in the mirror casing, for example, on an actuator.

54 Claims, 13 Drawing Sheets

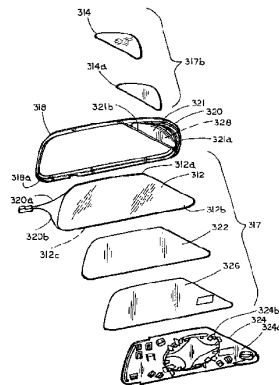

EXHIBIT D

10

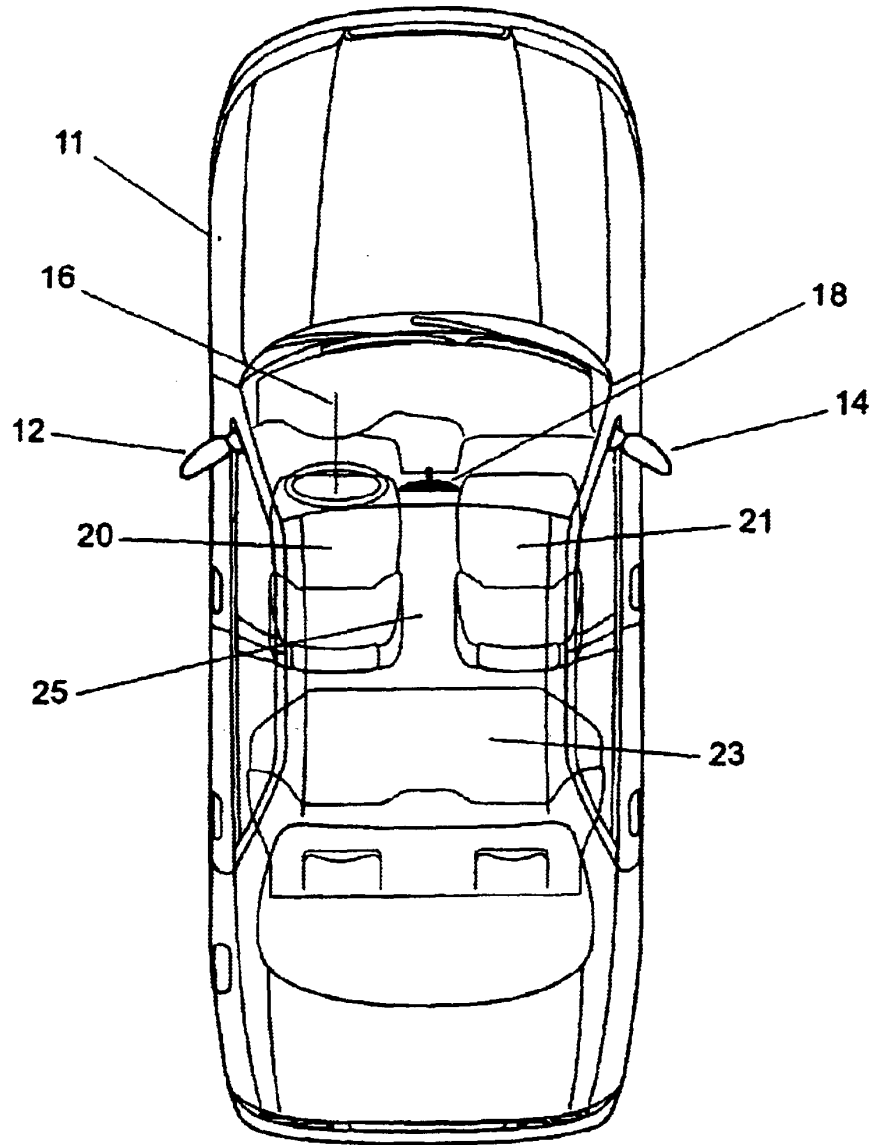

Figure 1

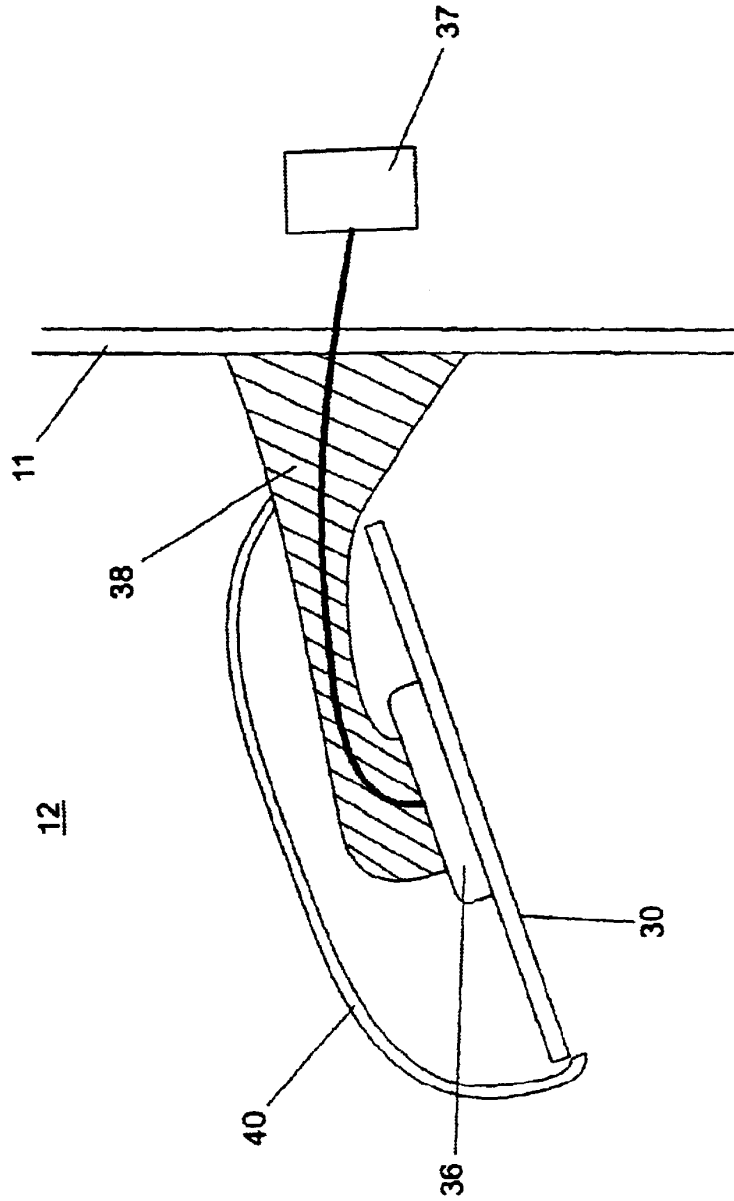

Figure 2

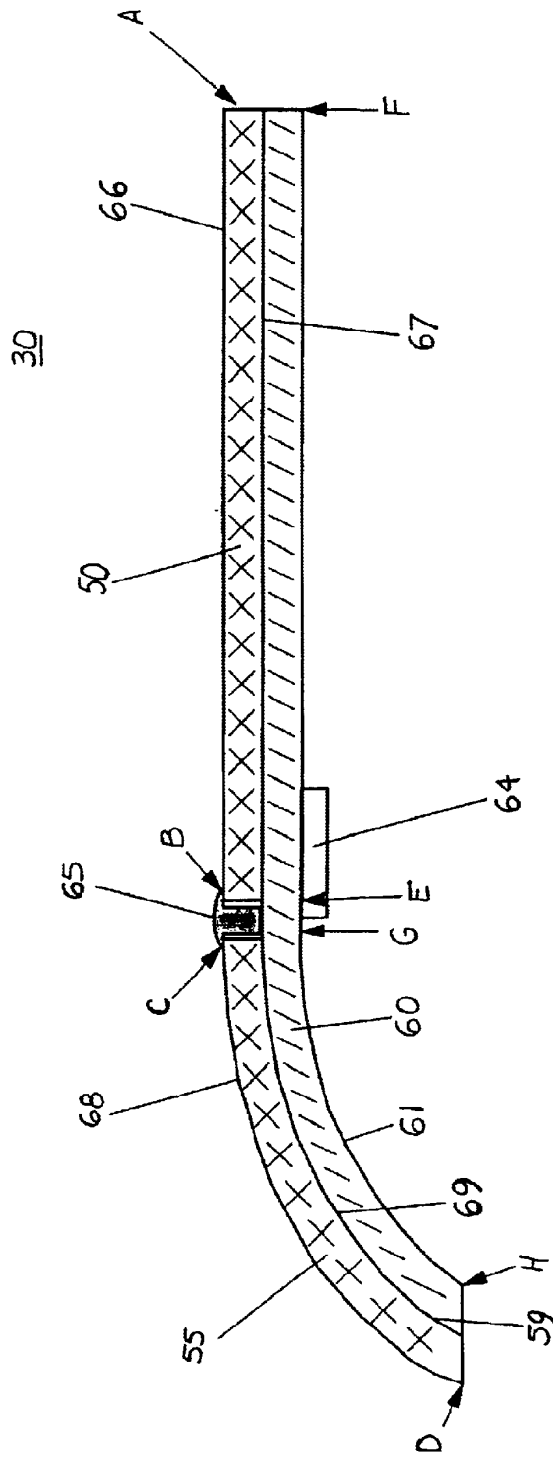

Figure 3

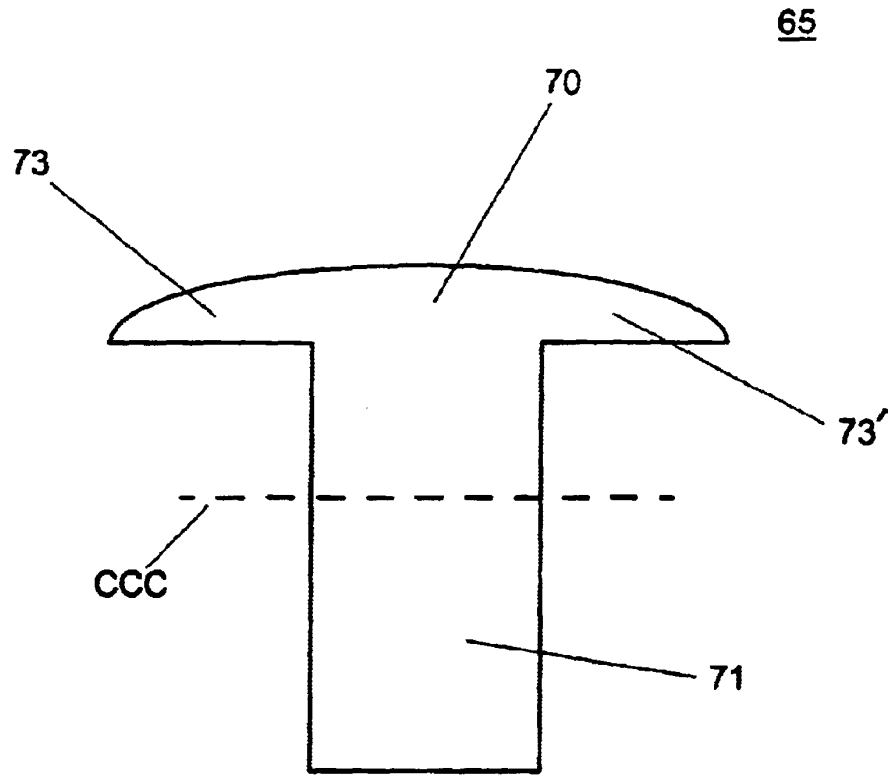
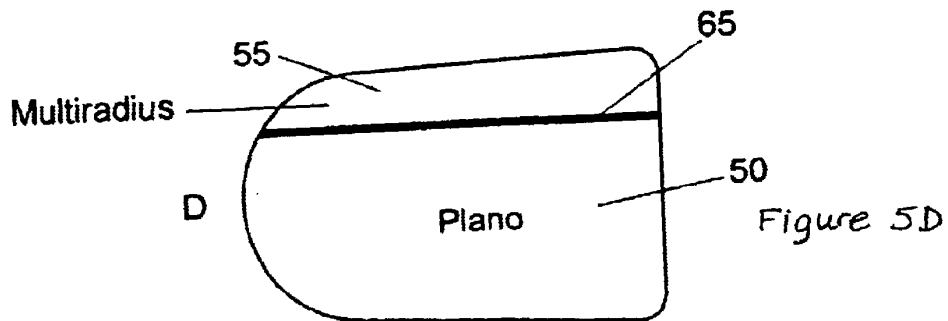
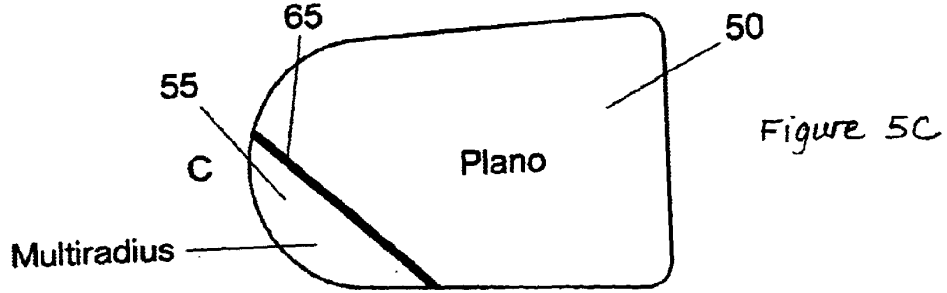
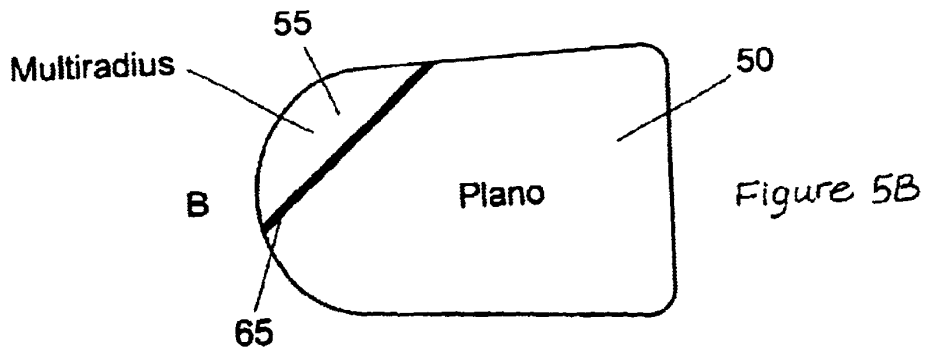
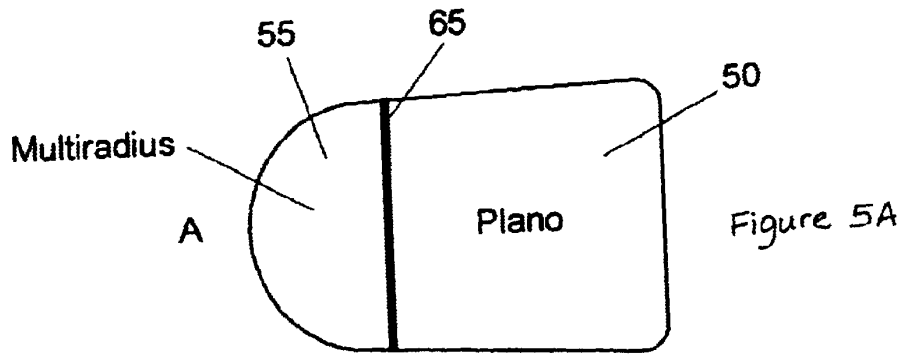
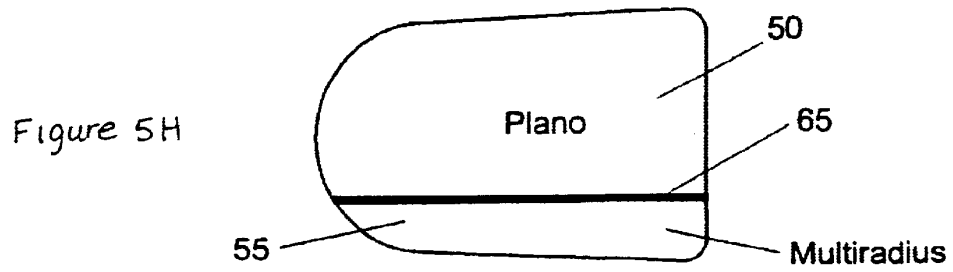
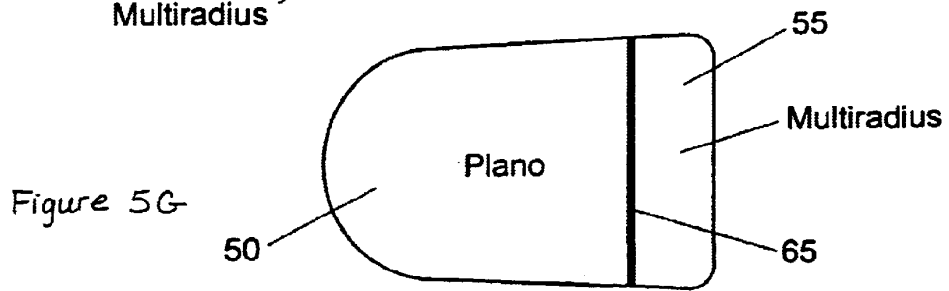
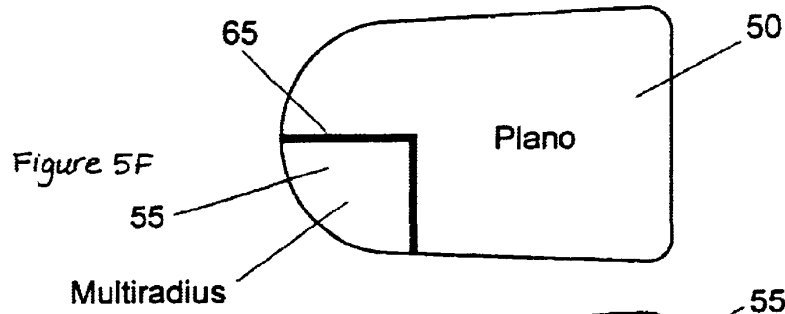
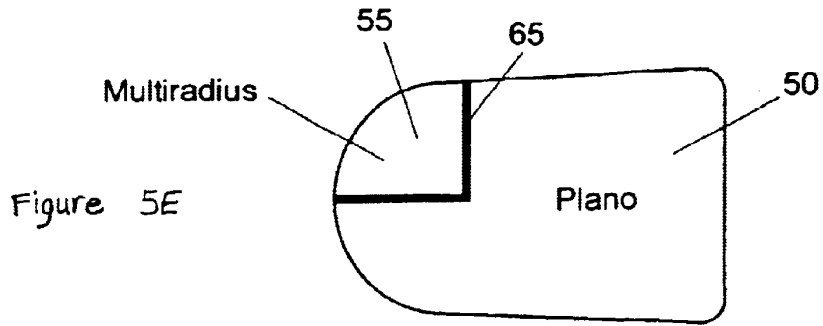

Figure 4





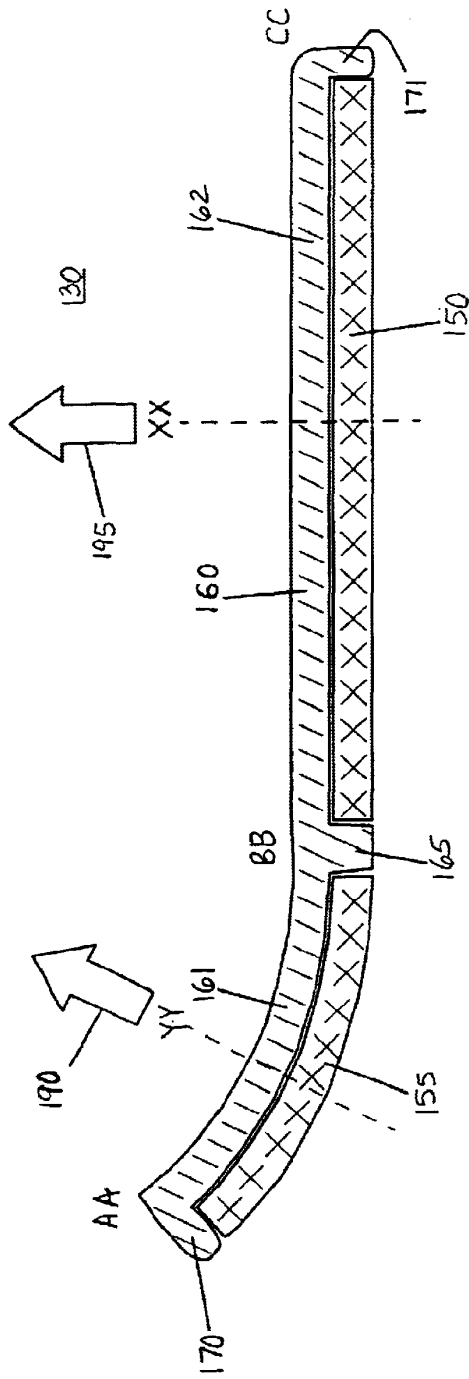

Figure 6

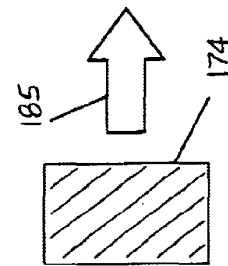

Figure 6A

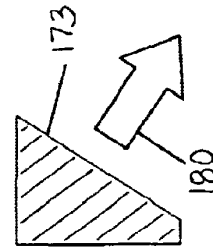

Figure 6B

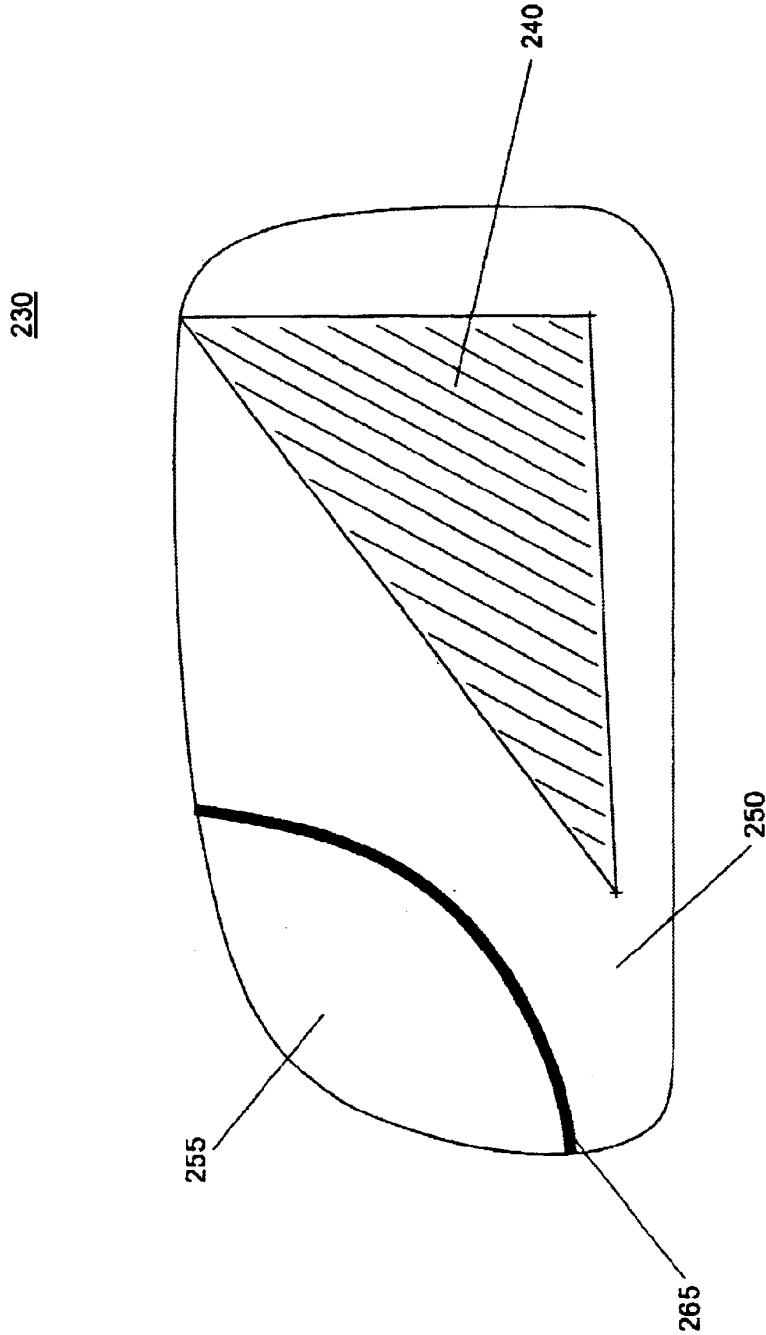

Figure 7

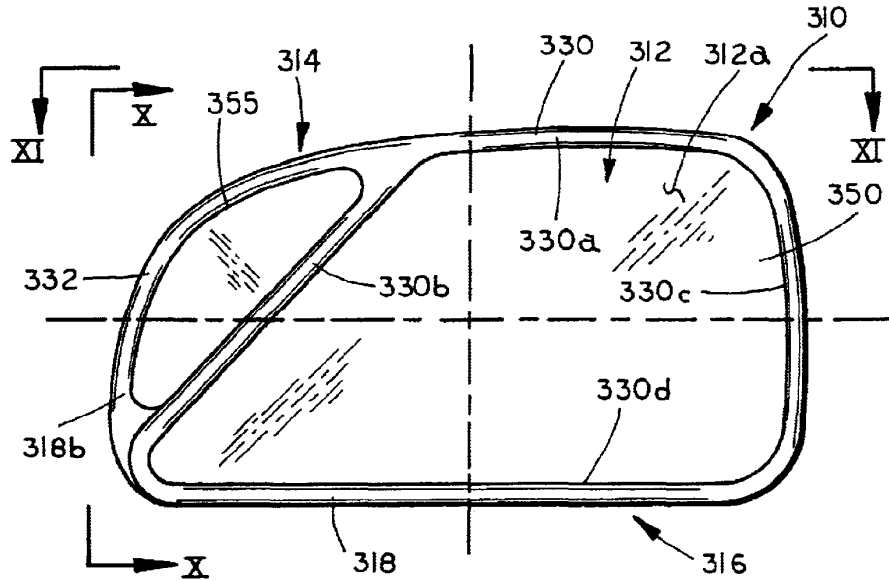

FIG. 8

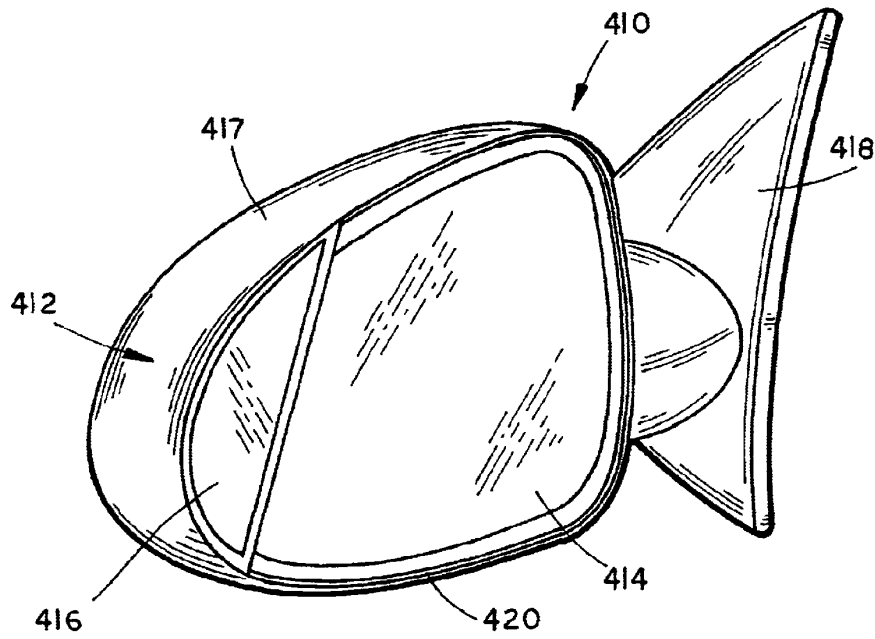

FIG. 15

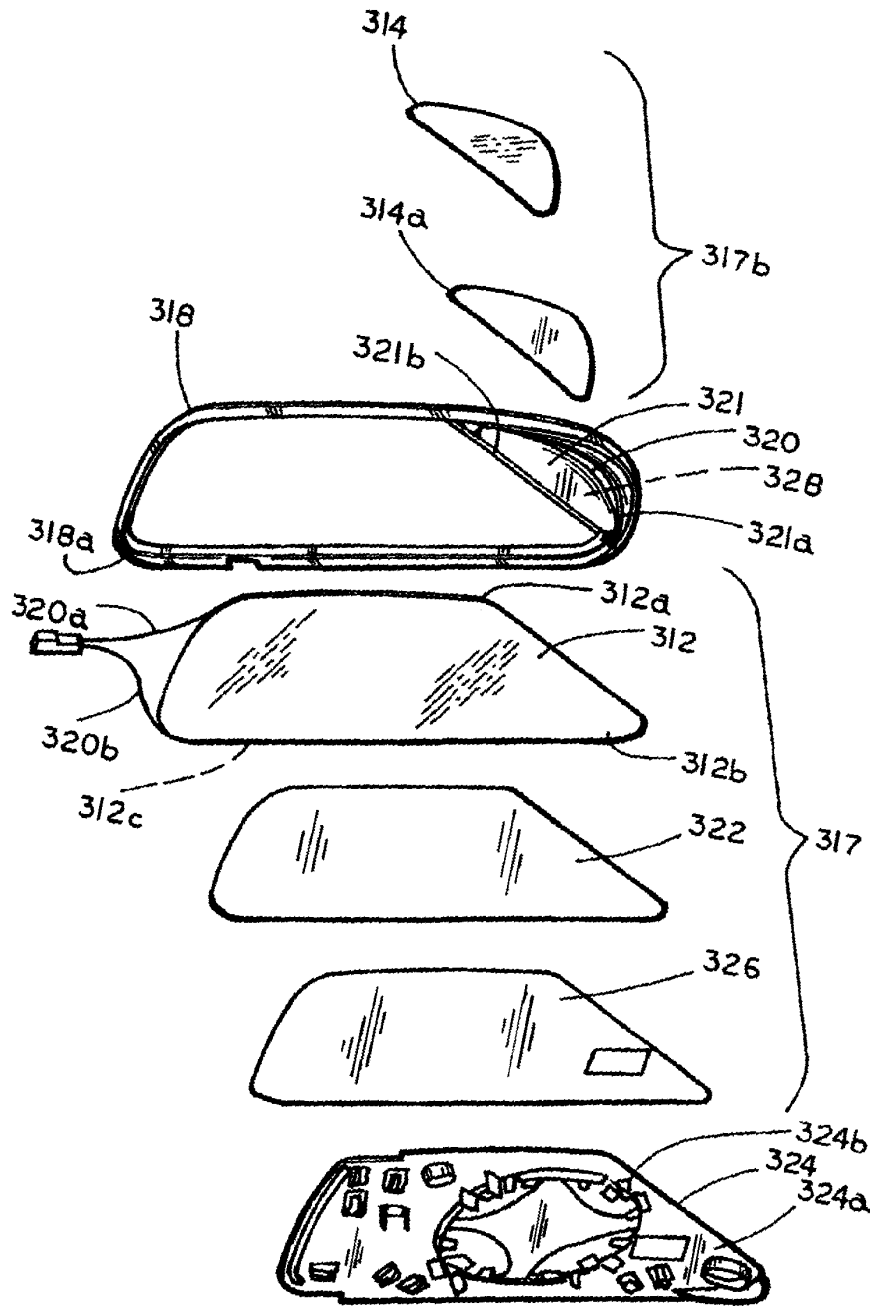

FIG.9

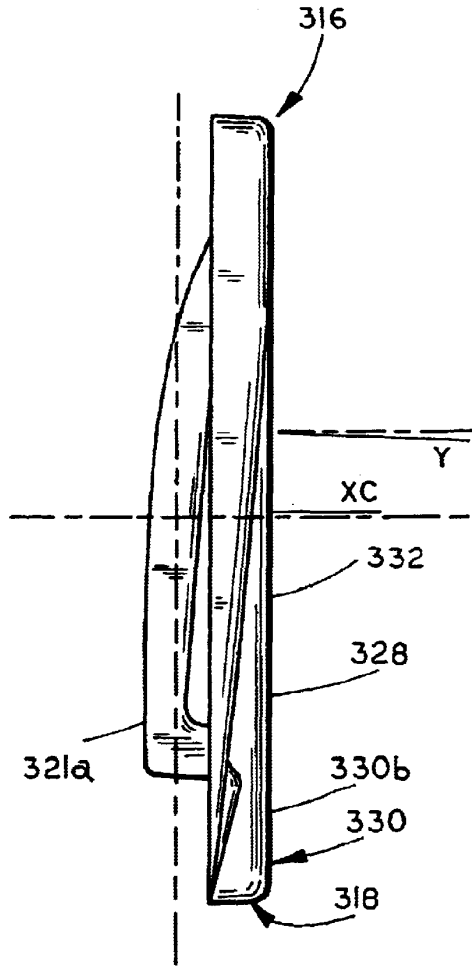

FIG. 10

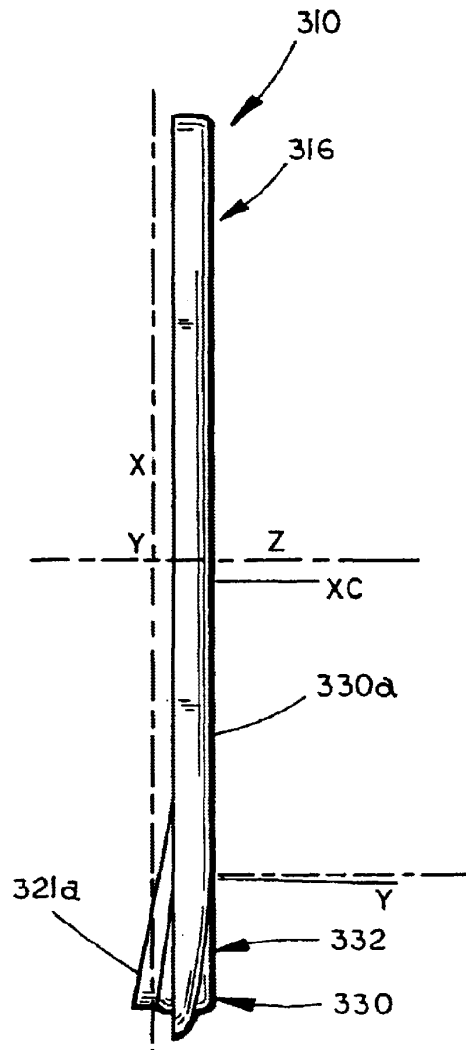
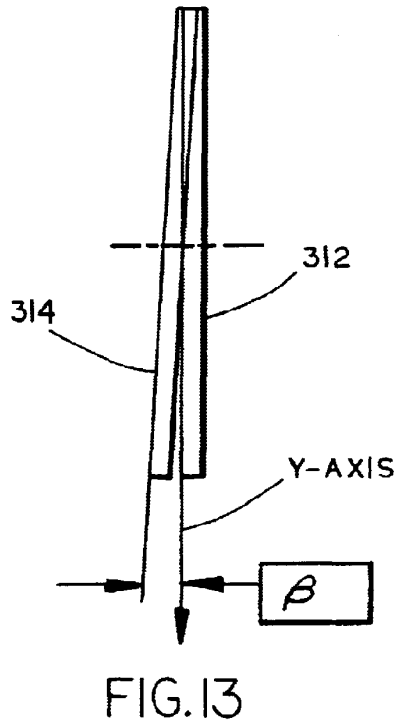
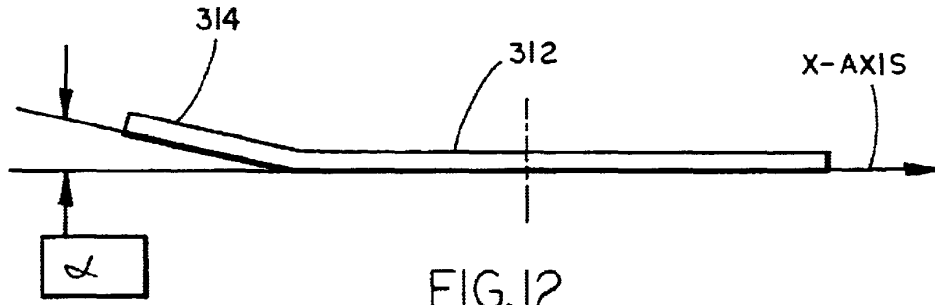

FIG. 11



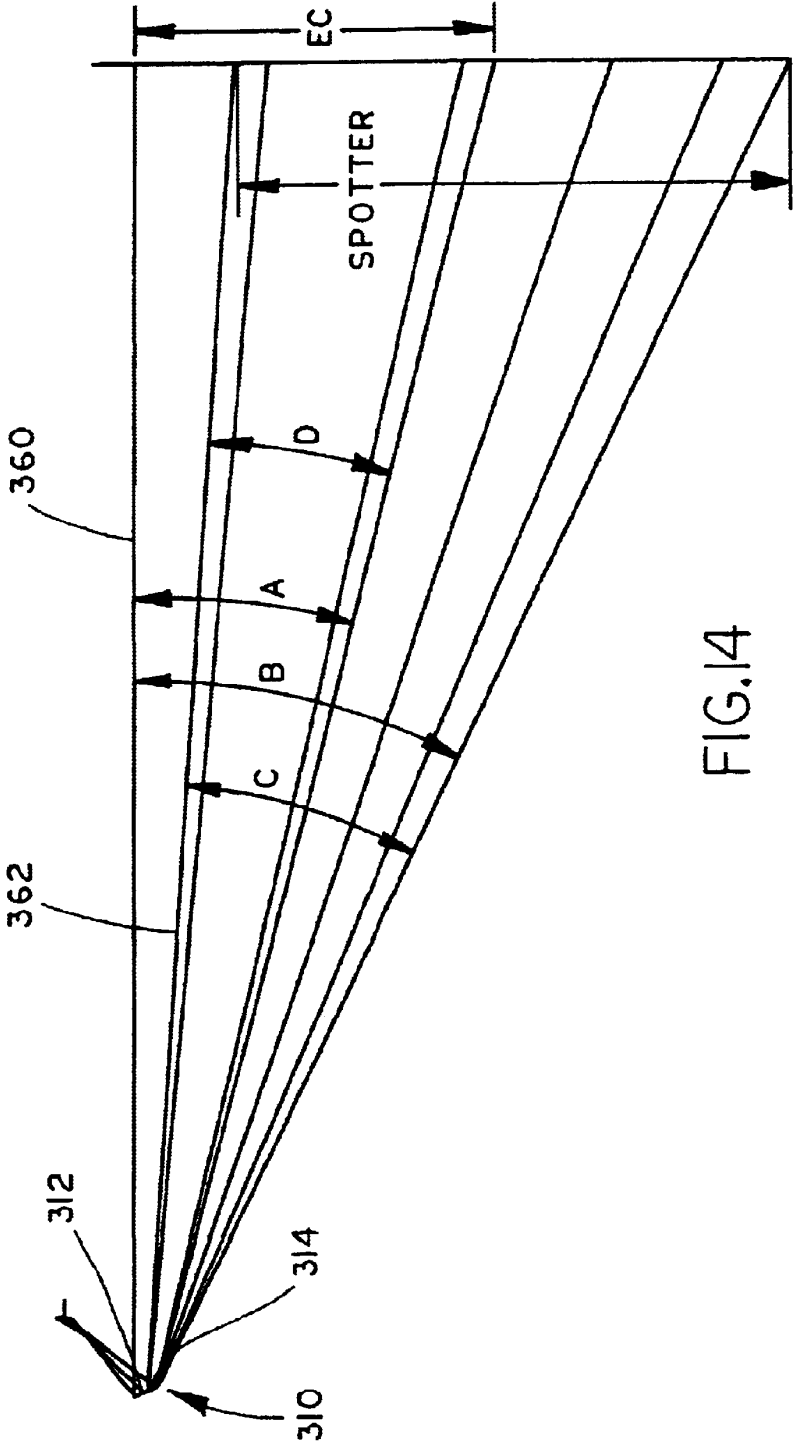

FIG. 14

1

EXTERIOR MIRROR PLANO-AUXILIARY REFLECTIVE ELEMENT ASSEMBLY

This is a continuation-in-part of U.S. patent application Ser. No. 09/478,315, filed Jan. 6, 2000, entitled "EXTE- 5
RIOR MIRROR PLANO-AUXILIARY REFLECTIVE
ELEMENT ASSEMBLY", now U.S. Pat. No. 6,522,451,
which is incorporated by reference herein in its entirety.

TECHNICAL FIELD AND BACKGROUND OF THE INVENTION

The present invention relates to exterior sideview mirror assemblies suitable for use on an automobile, and more specifically, to plano-auxiliary reflective element assemblies for use in automobile exterior sideview mirror assemblies.

Automobiles are typically equipped with an interior rearview mirror assembly (adapted for providing a rearward field of view immediately rearward of the vehicle, typically principally in the road lane the vehicle is traveling in) and at least one exterior sideview mirror assembly attached to the side of the vehicle (typically adjacent a front side window portion). The exterior side view mirror assembly typically comprises a reflective element adapted to provide a rearward field of view of the side lane adjacent the vehicle so as to allow the driver see whether a side approaching vehicle is present when the driver is contemplating a lane change. Conventionally, automobiles are equipped with a driver-side exterior mirror assembly and, very often, with a passenger-side exterior sideview mirror assembly mounted to the side of the automobile body opposite to that of the driver-side assembly. While the combination of an interior rearview mirror with a driver-side exterior mirror (and especially in a three-mirror system comprising an interior rearview mirror with a driver-side exterior mirror and a passenger-side exterior mirror) works well in many driving situations, rear vision blind spots present a potential safety hazard while driving. A rear vision blind spot is an area adjacent the side of an automobile where a view of another vehicle (overtaking on that side) is not captured in the rearward field of view of the exterior mirror reflector on that side. This presents a potential safety hazard as the driver, upon checking the view in the exterior sideview mirror and seeing no overtaking vehicle therein, may deem it safe to initiate a lane change, unaware that there is a vehicle immediately adjacent in a blind-spot of the exterior mirror reflector.

Various attempts have been made conventionally to minimize and/or eliminate exterior mirror blind-spots on vehicles. One approach is to make the exterior mirror reflector larger, and particularly wider with respect to the vehicle body. By increasing the width of the exterior mirror reflector, it has a wider field of view rearwards, and hence the reflector blindspot is reduced. While use of a wide exterior mirror reflector is an option for trucks, buses and commercial vehicles, increasing the width of the reflector used in an exterior sideview mirror assembly mounted on automobiles (such as sedans, station wagons, sports cars, convertibles, minivans, sports utility vehicles, pick-up trucks and similar passenger carrying automobiles) is often not an option. In such domestic automobiles, increasing the width of the exterior mirror reflector increases the size of the exterior sideview mirror assembly with a concomitant increase in aerodynamic drag, increase in fuel consumption, increased difficulty in parking in tight parking spaces, and increased reflector vibration. Use of a non-flat, curved exterior mirror reflector is commonly used to increase rearward field of view without increasing reflector size.

2

While working well to increase field of view, use of a curved reflector (such as a convex, spherically-curved reflector) has disadvantages. The field of view rearward increases as the degree of curvature of the bent substrate increases (i.e., the field of view rearward increases as the radius of curvature of the bent substrate decreases). However, such wide-angle mirrors have non-unit magnification and distance perception rearward is distorted. For this reason, convex (spherically-bent) exterior mirror reflectors are required in some countries (such as the United States) to carry a safety warning "OBJECTS IN MIRROR ARE CLOSER THAN THEY APPEAR". Distance perception is particularly important for a driver-side exterior mirror. Indeed, Federal Vehicle Safety Standard No: 111 in the United States (the entire disclosure of which is hereby incorporated by reference herein) requires that the driver-side exterior mirror reflector exhibit unit magnification, and places restrictions on the radius of curvature allowed for any bent passenger-side mirror as well as requiring a safety warning be placed thereon. As an improvement over spherically bent/convex mirror reflectors, aspherical or multiradius mirror reflectors (such as are disclosed in U.S. Pat. Nos. 4,449,786 and 5,724,187, the entire disclosures of which are hereby incorporated by reference herein) have been developed. Such mirrors are widely used in Europe and Asia for both driver-side exterior mirror reflectors and for passenger-side exterior mirror reflectors. The aspherical or multiradius mirror reflectors typically have a less curved (larger radius of curvature) reflective region that is inboard or closest to the driver when mounted on a vehicle and, usually separated by a demarcation line or the like, have a more curved (smaller radius of curvature) region that is outboard or farthest from the driver when mounted on a vehicle. However, such aspherical or multiradius reflectors do not have unit magnification and so cannot be used when unit magnification is mandated (such as by FMVSS 111, referenced above).

To supplement a flat driver-side exterior mirror reflector, an auxiliary and separate bent reflector is sometimes incorporated into the driver-side exterior sideview mirror assembly. However, this is often not suitable for passenger automobiles because of the extra space required in the sideview mirror assembly to accommodate an auxiliary reflector element. Also, in most passenger automobiles, the position of the side view mirror reflector is adjustable by the driver (such as by a hand-adjust, or by a manually adjustable cable such as a Bowden cable or by an electrically operable actuator, as known in the art) in order to provide to that driver his or her desired rearward field of view, which ill-suits use of a separate, auxiliary reflector. Likewise, addition of stick-on blind-spot mirror reflectors (such as are commonly sold in automotive parts stores and the like) onto an automobile exterior sideview mirror reflector has disadvantages, including obscuring field of view of the automobile mirror reflector and adding to mirror element vibration.

There is thus a need to provide an automobile exterior sideview reflective element, and particularly a driver-side automobile exterior sideview reflective element, that overcomes the disadvantages above and that provides the driver of the automobile with a distortion-free field of view with unit magnification that is supplemented with a wide-angle view of a side lane blind spot, and there is a need that this be provided in a unitary reflective element assembly module suitable to mount onto, and be adjusted by, the mirror reflector adjustment mechanism (such as an electrically operated, motorized actuator) provided in the exterior sideview mirror assembly.

SUMMARY OF THE INVENTION

According to the present invention, an automobile exterior sideview mirror system includes an exterior sideview mirror assembly having a reflective element assembly. The reflective element assembly includes a first reflective element and a second reflective element, which together provide an increased field of view for the exterior side mirror assembly.

In one form of the invention, an automobile exterior side mirror system includes an exterior side mirror assembly, which is adapted for attachment to a side of an automobile. The exterior sideview mirror assembly includes a reflective element assembly having a plano reflective element, which forms a first reflective element, and a multiradiused reflective element which forms a second reflective element. The reflective element assembly is mounted to an actuator, which moves the reflective element assembly to position the rearward field of view of the reflective element assembly. The reflective element assembly further includes a frame element assembly to which the first and second reflective elements are mounted and which orients the second reflective element such that it has a viewing range which spans outwardly and downwardly with respect to the first reflective element to thereby provide an increased field of view for the exterior sideview mirror assembly.

In one aspect, the first reflective element and the second reflective element are adjacently attached to the frame element assembly at a joint. The reflective element assembly further includes a demarcation element disposed at its joint to form a demarcation between the first and second reflective elements that is visible to the driver. In a further aspect, the frame element assembly includes a bezel portion which extends around the first reflective element, with the demarcation element comprising a segment of the first bezel portion.

In another aspect, the second reflective element comprises a bent glass substrate with radii of curvature in the range of about 4000 mm to about 100 mm.

In yet another aspect, the frame element assembly includes a frame, with the first and second reflective elements being mounted in the frame. The multiradiused reflective element is mounted to the frame at an outboard position, with the plano reflective element being positioned adjacent the multiradiused reflective element and at an inboard position with respect to the multiradiused reflective element when the exterior side mirror assembly is mounted to an automobile. In a further aspect, the plano reflective element is mounted to the frame by a backing plate, which is preferably adapted to mount to the actuator.

In other aspects, the first reflective element includes a rearward field of view having a principal axis, which is different from and angled to a principal axis of the rearward field of view of the second reflective element when the reflective element assembly is mounted in the exterior sideview mirror assembly. The principal axis of the rearward field of view of the second reflective element is directed generally outwardly and downwardly with respect to a longitudinal axis of the automobile when the exterior side mirror system is mounted to an automobile. For example, the principal axis of the rearward field of view of the second reflective element may form a downward angle with respect to the principal axis of the rearward field of view of the first reflective element in the range from about 0.75° to about 5°, or in a range of about 1.5° to about 3.5°, in a range of about 2° to about 3°.

In other aspects, the principal axis of the second reflective element forms an outward angle with respect to the principal

axis of the rearward field of view of the first reflective element in a range of about 0.75° to about 5°, or in a range of about 1° to about 3°, or in a range of about 1.25° to about 2.5°.

According to another form of the invention, an automobile exterior side mirror system includes an exterior side mirror assembly, which is adapted for attachment to a side of an automobile. The exterior side mirror assembly includes a mirror casing, a reflective element assembly, and an actuator. The reflective element assembly includes a frame element assembly, a first reflective element having a unit magnification, and a second reflective element having a multiradiused curvature. The frame element assembly mounts the first reflective element and the second reflective element in the mirror casing and is adapted to mount to the actuator, which adjusts the orientation of the reflective element assembly. The first reflective element has a first rearward field of view with a first principal axis, and the second reflective element has a second rearward field of view with a second principal axis, with the second principal axis being angled outwardly and downwardly with respect to the first principal axis.

In one aspect, the second principal axis is angled outwardly from the first principal axis at an angle in a range of about 0.75° to about 5°, or in a range of approximately 1° to about 3°, or at an angle in a range of about 1.25° to about 2.5°.

In another aspect, the second principal axis is angled downwardly from the first principal axis at an angle in a range of approximately 0.75° to about 5°, or in a range of about 1.5° to about 3.5°, or at an angle in a range of about 2° to about 3°.

In another aspect, the frame includes a support surface for the second reflective element, with the support surface angling the second principal axis of the second reflective element.

In yet another form of the invention, an automobile exterior sideview mirror system includes an exterior sideview mirror assembly, which is adapted for attachment to a side of an automobile. The mirror assembly includes an actuator and a reflective element assembly. The reflective element assembly includes a frame element assembly, a first reflective element, and a second reflective element. The frame element assembly is adapted to mount to the actuator and includes a frame and a support surface for the second reflective element. The actuator adjusts the position of the reflective element assembly to thereby adjust the viewing angle of the sideview mirror system. The support surface angles the second reflective element downwardly and forwardly of the first reflective element when the mirror assembly is mounted to an automobile whereby the second reflective element provides a viewing range which spans outwardly and downwardly with respect to the automobile to thereby provide an increased field of view for the exterior sideview mirror assembly.

In one aspect, the support surface is provided by a plate element, for example a solid plate element or a foraminous plate element. In other aspects, the support surface is provided by a frame.

In further aspects, the frame includes a first bezel portion and a second bezel portion, with the first bezel portion extending around the first reflective element, and the second bezel portion extending around the second reflective element. In one form, the second bezel portion is angled forwardly with respect to the first bezel portion when said exterior sideview mirror assembly is mounted to a side of an automobile.

5

In another aspect, the second reflective element is located outboard of the first reflective element.

These and other advantages, features, and modifications will become more apparent when reviewed in conjunction with the drawings and the detailed description which follows.

BRIEF DESCRIPTION OF THE DRAWINGS

FIG. 1 is a perspective view of an automobile equipped with exterior sideview mirror assemblies according to this present invention;

FIG. 2 is a top plan partial fragmentary view of the driver's side exterior rearview mirror assembly of FIG. 1;

FIG. 3 is an enlarged sectional view of a plano-multiradius reflective element assembly of the mirror assembly in FIG. 2;

FIG. 4 is an enlarged sectional view of a demarcation element of the plano-multiradius reflective element assembly of FIG. 3;

FIGS. 5A-5H illustrate views of various locations for a plano reflective element and an auxiliary reflective element according to this present invention;

FIG. 6 is a sectional view of a second embodiment of a plano reflective element assembly according to the present invention including a demarcation element formed as a dividing wall in a backing plate element;

FIG. 6A is a cross-section taken along line XX of FIG. 6;

FIG. 6B is a cross-sectional view taken along line YY of FIG. 6;

FIG. 7 is a schematic of a third embodiment of a plano-auxiliary reflective element assembly according to this present invention;

FIG. 8 is a front elevation view of another embodiment of a plano reflective element assembly according to the present invention;

FIG. 9 is an exploded perspective view of the plano reflective element assembly of FIG. 8;

FIG. 10 is an end view of the plano reflective element assembly of FIG. 8 as viewed from line X-X of FIG. 8;

FIG. 11 is a top view of the plano reflective element assembly of FIG. 8 as viewed from line XI-XI of FIG. 8;

FIG. 12 is a schematic representation of the plano reflective element assembly of FIG. 8 illustrating the orientation of the reflective element;

FIG. 13 is another schematic representation of the orientation of the reflective elements of the plano reflective element in FIG. 8;

FIG. 14 is a diagram illustrating the range of viewing of the reflective elements of the plano reflective element assembly of FIG. 8; and

FIG. 15 is a perspective view of another embodiment of an exterior rearview mirror system of the present invention.

DETAILED DESCRIPTION OF THE PREFERRED EMBODIMENTS

As illustrated in FIG. 1, passenger automobile 10 (which may be a sedan, a station-wagon, a sports car, a convertible, a minivan, a sports utility vehicle, a pick-up truck or a similar passenger carrying non-commercial, personal transportation automobile) includes an interior rearview mirror assembly 18 positioned within interior vehicle cabin 25. Interior vehicle cabin 25 further includes a steering wheel 16, a driver seat 20 positioned at steering wheel 16, a front

6

passenger seat 21 adjacent to driver seat 20 in the front portion of cabin 25, and a rear passenger seat 23 in the rear portion of cabin 25. Automobile 10 further includes a driver-side exterior sideview mirror assembly 12 and a passenger-side exterior sideview mirror assembly 14, each adapted for attachment to opposing sides of automobile body 11, most preferably adjacent to the seating position of the driver seated in driver seat 20 for driver-side assembly 12 and adjacent to the front passenger seat 21 for passenger-side assembly 14. Exterior sideview mirrors, mounted as shown in FIG. 1 close to the driver seating location, are commonly referred to as door-mounted exterior sideview mirror assemblies. Driver-side exterior sideview mirror assembly 12 includes, as illustrated in FIG. 2, a plano-multiradius exterior sideview reflective element assembly 30. Plano-multiradius reflective element assembly 30 is mounted to a reflective element positioning actuator 36. The orientation of plano-multiradius reflective element assembly 30, and hence its rearward field of view, is adjustable by actuator 36 in response to control 37. Control 37 can comprise a handset control that allows the driver manually move the orientation of plano-multiradius reflective element assembly 30 within exterior mirror housing 40 (such as by a lever control or by a cable control) and hence reposition the rearward field of view of plano-multiradius reflective element assembly 30. Alternately, when actuator 36 comprises an electrically actuated actuator that is electrically operable incorporating at least one motor, control 37 can comprise a switch (which, preferably, is operable under control of the driver seated in cabin 25) or control 37 can comprise a memory controller, as known in the automotive mirror art, that controls actuator 36 to move the position of plano-multiradius reflective element assembly 30 to a pre-set orientation that suits the rearward field of view preference of an individual driver. Actuator 36 is mounted to bracket 38 which attaches to vehicle body side 11. Plano-multiradius reflective element assembly 30 is positionable by actuator 36 within exterior mirror housing 40.

Plano-multiradius reflective element assembly 30, as shown in FIG. 3, comprises a plano element 50 and a separate multiradius element 55. Preferably, plano element 50 is adjacent to multiradius element 55 at a joint. At their joint, plano element 50 and separate multiradius element 55 can touch leaving substantially no gap or space therebetween, or plano element 50 and separate multiradius element 55 can be spaced apart at their joint by a space or gap, as in FIG. 3. Plano element 50 and multiradius element 55 are both mounted to surface 59 of, and are both supported by, a single backing plate element 60. Plano element 50 and multiradius element 55 are demarcated apart by demarcation element 65. Surface 61 of backing plate element 60 is preferably adapted to attach, such as by attachment member 64, to actuator 36 when plano-multiradius reflective element assembly 30 is mounted in driver-side exterior sideview mirror assembly 12 (and/or in passenger-side exterior side view mirror assembly 14) such that plano element 50 and multiradius element 55 are adjusted and positioned in tandem and simultaneously when the driver (or alternatively, when a mirror memory system, as is conventional in the rearview mirror arts) activates actuator 36 to reposition the rearward field of view of plano-multiradius reflective element assembly 30. Thus, since elements 50, 55 are part of plano-multiradius reflective element assembly 30, movement of plano-multiradius reflective element assembly 30 by actuator 36 simultaneously and similarly moves plano element 50 and multiradius element 55.

Plano element 50 preferably comprises a flat reflector-coated glass substrate having unit magnification, and com-

prises a reflective surface through which the angular height and width of the image of an object is equal to the angular height and width of the object when viewed at the same distance (except for flaws that do not exceed normal manufacturing tolerances). Plano element **50** may comprise a conventional fixed reflectance mirror reflector or it may comprise a variable reflectance mirror reflector whose reflectivity is electrically adjustable. For example, plano element **50** may comprise a flat glass substrate coated with a metallic reflector coating such as a chromium coating, a titanium coating, a rhodium coating, a metal alloy coating, a nickel-alloy coating, a silver coating, an aluminum coating (or any alloy or combination of these metal reflectors). The metal reflector coating of plano element **50** may be a first surface coating (such as on surface **66**) or a second surface coating (such as on surface **67**), as such terms are known in the mirror art. The reflector coating on plano element **50** may also comprise a dielectric coating, or a multilayer of dielectric coatings, or a combination of a metal layer and a dielectric layer to form automotive mirror reflectors as known in the automotive mirror art. If a variable reflectance reflector element, plano element **50** preferably comprises an electro-optic reflector element and, most preferably, an electrochromic reflector element.

When mounted into exterior side view mirror assembly **12** and/or **14**, plano-multiradius reflective element assembly **30** is preferably orientated so that at least a portion of (more preferably a substantial portion of) the reflector surface of plano element **50** is positioned closer to the vehicle body (and hence to the driver) than any portion of the reflector surface of multiradius element **55**. Thus, and referring to FIG. **3**, side A of plano element **50** of plano-multiradius reflective element assembly **30** is positioned closer to the driver than side D of multiradius element **55** when plano-multiradius reflective element assembly **30** is mounted on an automobile. Also, when mounted into exterior side view mirror assembly **12** and/or **14**, surfaces **66**, **68** of plano-multiradius reflective element assembly **30** face rearwardly in terms of the direction of vehicle travel.

Multiradius element **55** of plano-multiradius reflective element assembly **30** preferably comprises a curved/bent mirrored glass substrate. The degree of curvature preferably increases (and hence the local radius of curvature decreases) across the surface of multiradius element **55** with the least curvature (largest radius of curvature) occurring at the side of multiradius element **55** (side C in FIG. **3**) positioned adjacent its joint to plano element **50** when both are mounted on backing plate element **60**. Thus, and referring to FIG. **3**, the local radius of curvature at side C of multiradius element **55**, when mounted on backing plate element **60**, is larger than at side D. Also, the local radius of curvature preferably progressively decreases across multiradius element **55** from side C to side D. Preferably, the local radius of curvature at side C of multiradius element **55** is at least about 1000 mm; more preferably is at least about 2000 mm and most preferably is at least about 3000 mm whereas the local radius of curvature at side D of multiradius element **55** is, preferably, less than about 750 mm, more preferably less than about 350 mm; most preferably less than about 150 mm. Preferably, multiradius element **55** comprises a bent glass substrate with radii of curvature in the range of from about 4000 mm to about 50 mm. The multiradius prescription for the multiradius element to be used in a particular exterior mirror assembly can vary according to the specific field of view needs on a specific automobile model.

The total field of view rearwardly of the automobile of the plano-auxiliary reflective element assembly (which is a

combination of the field of view of the plano reflective element and of the auxiliary reflective element) preferably generally subtends an angle of at least about 20° (and more preferably, generally subtends an angle of at least about 25° and most preferably, generally subtends an angle of at least about 30°) with respect to the side of an automobile to which is attached an exterior sideview mirror assembly equipped with the plano-auxiliary reflective element assembly.

Multiradius element **55** may comprise a conventional fixed reflectance mirror reflector or it may comprise a variable reflectance mirror reflector whose reflectivity is electrically adjustable. For example, multiradius element **55** may comprise a flat glass substrate coated with a metallic reflector coating such as a chromium coating, a titanium coating, a rhodium coating, a metal alloy coating, a nickel-alloy coating, a silver coating, an aluminum coating (or any alloy or combination of these metal reflectors). The metal reflector coating of multiradius element **55** may be a first surface coating (such as on surface **68**) or a second surface coating (such as on surface **69**), as such terms are known in the mirror art. The reflector coating on multiradius element **55** may also comprise a dielectric coating, or a multilayer of dielectric coatings, or a combination of a metal layer and a dielectric layer to form automotive mirror reflectors as known in the automotive mirror art. If a variable reflectance reflector element, multiradius element **55** preferably comprises an electro-optic reflector element and, most preferably, an electrochromic reflector element.

Also, it is preferable that the thickness of plano element **50** and multiradius element **55** be substantially the same in dimension so that their respective outer surfaces, **66** and **68**, are substantially coplanar so that a driver can readily view images in either or both elements. The thickness dimension of elements **50**, **55** is determined by the thickness of the substrate (or in the case of laminate-type electrochromic reflective elements, the thickness of the two substrates between which the electrochromic medium is disposed). For example, plano element **50** and/or multiradius element **55** can comprise a reflector coated glass substrate or panel of thickness preferably equal to or less than about 2.3 mm, more preferably equal to or less than about 1.6 mm, most preferably equal to or less than about 1.1 mm. Use of a thinner substrate is beneficial in terms of improving the overall stability/vibration performance of the image seen in plano-multiradius reflective element assembly **30** when mounted to an automobile.

The reflector area of plano element **50** is preferably larger than that of multiradius element **55**. Preferably, the width dimension of plano element **50** is larger than the width dimension of multiradius element **55** (both width dimensions measured at their respective widest dimension and with the width of the respective element being gauged with the respective element oriented as it would be orientated when mounted on the automobile). Thus, and referring to FIG. **3**, the distance from side A to side B of plano element **50** is larger than the distance from side C to side D of multiradius element **55**. Thus, the ratio of the width of plano element **50** to the width of multiradius element **55** is preferably greater than 1; more preferably greater than 1.5; most preferably greater than 2.5 in order to provide a large, unit magnification plano element **50** as the principal rear viewing portion of plano-multiradius reflective element assembly **30** and providing multiradius element **55** as a smaller, auxiliary, separate, wide-angle viewing portion of plano-multiradius reflective element assemblies to be mounted to the exterior sideview assemblies of passenger

automobiles used non-commercially and for non-towing purpose, the width of plano element 50 (at its widest dimension) is preferably in the range of from about 50 mm to about 225 mm; more preferably in the range of from about 75 mm to about 175 mm; most preferably in the range of

5 from about 100 mm to about 150 mm.

Backing plate element 60 is preferably a rigid polymeric substrate capable of supporting plano element 50 and multiradius element 55. Backing plate element 60 comprises a flat portion (generally between E and F as shown in FIG. 3) that corresponds to and is aligned with plano element 50. Backing plate element 60 also comprises a curved portion (generally between G and H as shown in FIG. 3) that corresponds to and is aligned with multiradius element 55. Preferably, curved portion G-H of multiradius element 55 is fabricated with a multiradius prescription that is substantially the same as the multiradius prescription of multiradius element 55. Backing plate element 60 is formed as a single element to which elements 50 and 55 are separately attached. Preferably, backing plate element 60 is formed by injection molding of a thermoplastic or a thermosetting polymer resin. Materials suitable to use for backing plate element 60 include unfilled or filled polymeric materials such as glass and/or mineral filled nylon or glass and/or mineral filled polypropylene, ABS, polyurethane and similar polymeric materials. For example, backing plate element 60 can be formed of ABS in an injection molding operation. Plano element 50 can be cut from a stock lite of flat chromium mirror-coated 1.6 mm thick glass. Multiradius element 55 can be cut from a stock lite of multiradiusly-bent chromium mirror-coated 1.6 mm thick glass. Plano element 50 and multiradius element 55 can then be attached (such as by an adhesive attachment such as an adhesive pad or by mechanical attachment such by clips, fasteners or the like) to the already molded backing plate element 60. Alternatively, plano element 50 and multiradius element 55 can each be individually loaded into an injection molding tool. Once loaded, a polymeric resin (or the monomers to form a polymeric resin) can be injected into the mold in order to integrally form backing plate element 60 with elements 50, 55 integrally molded thereto. Integral molding of the backing plate element to plano element 50 and multiradius element 55 (along with any other elements such as the demarcation element 65) in a single integral molding operation, is a preferred fabrication process for plano-multiradius reflective element assembly 30.

Plano-multiradius reflective element assembly 30 further preferably includes demarcation element 65 that functions to delineate and demarcate the plano region of the assembly from the wide-angle, multiradius region and also preferably functions to prevent ingress of debris, dirt, water and similar contaminants (such as road splash, car wash spray, rain, snow, ice, leaves, bugs and similar items that plano-multiradius reflective element assembly 30 would be subject to when mounted and used on an automobile) into any gap between plano element 50 and multiradius element 55 when both are attached to backing plate element 60. Optionally, at least a portion of demarcation element 65 can be disposed in any gap between plano element 50 and multiradius element 55 at their joint on backing plate element 60. Preferably, demarcation element 65 is formed of a polymeric material that is dark colored (such as black or dark blue or dark brown or dark grey or a similar dark color) such as a dark colored polypropylene resin or a dark colored nylon resin or a dark colored polyurethane resin or a dark colored polyvinyl chloride resin or a dark colored silicone material. Most preferably demarcation element 65 is formed of an at least

partially elastomeric material (such as silicone, or EPDM, or plasticized PVC or the like) in order to provide a degree of vibration dampening for elements 50, 55. As shown in FIG. 4, demarcation element 65 optionally includes a crown portion 70 that includes wing portions 73, 73' and a stem portion 71. Stem portion 71 preferably has a cross-sectional width CCC of less than about 4 mm, more preferably less than about 3 mm and, most preferably less than about 2 mm. Crown portion 70 preferably is dimensioned to not protrude substantially beyond surfaces 66, 68 of elements 50, 55 when demarcation element 65 is installed between elements 50 and 55. Also, wings 73, 73' are preferably dimensioned to protrude (most preferably slightly) onto surfaces 66, 68 of elements 50, 55 when demarcation element 65 is installed between elements 50 and 55 in order to provide a weather barrier seal and/or to at least partially accommodate any dimensional tolerances of elements 50, 55 that could lead to variation in the inter-element gap between sides C and B. While the demarcation element shown in FIG. 4 is one embodiment, other constructions are possible including a demarcation element that has minimal or no crown portion. Likewise, a demarcation element can have little or no stem portion, especially when the joint between plano element 50 and multiradius element 55 includes no gap to receive a stem. Also, where a gap at the plano to multiradius joint exists, any stem of the demarcation element can at least partially be disposed in such gap so as to at least partially fill the gap (or it can optionally substantially fill the gap). Optionally, demarcation element 65 is fabricated by injection molding of a polymeric resin. After plano element 50 and multiradius element 55 have been attached to backing plate element 60, a separately formed demarcation element 65 can then be inserted (and secured such as by an adhesive or by a mechanical attachment such as by a fastener) into a space between elements 50 and 55. Note that, optionally, side B of plano element 50 and side C of multiradius element 55 can touch (leaving substantially no gap or space therebetween). In such a situation, demarcation element 65 can comprise a dark colored strip such as of a tape or of a plastic film that covers the joint between elements 50 and 55. Alternatively, demarcation element 65 can comprise a preferably dark-colored paint, lacquer, caulk or similar material that can be applied to, and that can preferably fill into, the joint between elements 50 and 55. The width of the portion of demarcation element 65 that is visible to the driver is preferably less than about 4 mm, more preferably less than about 3 mm and most preferably less than about 2 mm, but is equal to or greater than about 0.5 mm, more preferably is equal to or greater than about 0.75 mm, most preferably is equal to or greater than about 1 mm in order to provide adequate demarcation of the plano region from the multiradius radius region without unduly obscuring the rearward field of view of the respective elements. Optionally, demarcation element 65 can be formed as part of backing plate element 60 such as by forming demarcation element 65 as a wall structure of the backing plate element that partitions backing plate element 60 into two regions: A first region adapted to receive plano reflective element 50 and a separate and adjacent second region adapted to receive multiradius reflective element 55.

Thus, and referring to FIG. 6, a second embodiment of plano-multiradius reflective element assembly 130 may include a backing plate element 160 which comprises a plate molded from a polymer resin (such as a polyolefin such as polypropylene or such as ABS or nylon) with a demarcation element 165 that is molded as a wall structure that partitions backing plate element 165 into a first region (from CC to

11

BB) adapted to receive and accommodate plano reflective element **150** and into a second region (from BB to AA) adapted to receive and accommodate wide-angle optic multiradius reflective element **155**. Note that section AA to BB of backing plate element **160** is angled to section BB to CC. Such angling of the auxiliary reflective element relative to the plano element can be advantageous in allowing the auxiliary reflective element view a portion of the road adjacent the automobile that is in a blind spot of the plano reflective element. In this regard, it is preferable that the multiradius element be angled away from the plane of the plano element, as shown in FIG. 6 by the angling of section AA to BB to section BB to CC.

Preferably, demarcation element **65** is formed in an integral molding operation, along with formation of backing plate element **60**, and attachment of elements **50**, **55** thereto. For example, plano element **50** and multiradius element **55** can each be individually loaded into an injection molding tool. Once loaded, a polymeric resin (or the monomers to form a polymeric resin) can be injected into the mold in order to integrally form backing plate element **60** with elements **50**, **55** integrally molded thereto and, in the same molding operation and in the same tool, also form by molding the demarcation element. Integral molding of the backing plate element to plano element **50** and multiradius element **55** along with creation in the single molding operation of demarcation element **65** (along with any other elements such as attachment member **64**) in a single integral molding operation, is a preferred fabrication process for plano-multiradius reflective element assembly **30**. By loading all the sub components of plano-multiradius reflective element assembly **30** into a molding tool, and then injecting polymeric resin to form the backing plate, demarcation member and any attachment member, a substantially complete or fully complete plano-multiradius reflective element assembly can be unloaded from the tool at the completion of the integral molding operation (as known in the molding art), thus enabling economy in manufacturing and accommodation of any dimensional tolerances in the sub components. Where integral molding is so used, it is preferable to use a reactive molding operation such as reactive injection molding of a urethane as such reactive injection molding operations occur at relatively modest temperatures.

Plano element **50** and/or multiradius element **55** can comprise a heater element, as known in the automotive mirror art, that is operable to deice/demist surfaces **66**, **68**. Such heater elements are conventional and can comprise a positive temperature coefficient heater pad, a resistive heater element and/or a conductive coating. Plano element **50** and/or multiradius element **55** can also optionally comprise a scatterproofing member, as known in the automotive mirror art, such as an adhesive tape, to enhance safety in an accident.

Also, plano element **50** and/or multiradius element **55** can comprise a variable reflectance electro-optic element such as an electrochromic mirror reflector. Thus, both element **50** and element **55** can comprise an electrochromic mirror element or either of element **50** and element **55** can comprise an electrochromic mirror element and the other can comprise a fixed reflectance non-variable reflectance mirror element such as a metal reflector coated glass panel such as a chromium coated glass substrate. Also, if both plano element **50** and multiradius element **55** comprise an electro-optic element such as an electrochromic mirror element capable of electrically dimmable reflectivity, both elements **50**, **55** can dim together and in tandem under control of a common dimming control signal (typically provided by an

12

electro-optic automatic dimming interior mirror assembly mounted in the cabin of the automobile and equipped with photosensors to detect incident glare and ambient light). Alternately, if both plano element **50** and multiradius element **55** comprise an electrooptic element such as an electrochromic mirror element capable of electrically dimmable reflectivity, element **50** can dim independently of element **55** (such as is disclosed in U.S. Pat. No. 5,550,677, the entire disclosure of which is hereby incorporated by reference herein). If either or both of elements **50**, **55** comprise an electrochromic element, preferably, the electrochromic reflective element comprises a front substrate and a rear substrate with an electrochromic medium disposed between, such as a solid polymer matrix electrochromic medium such as is disclosed in U.S. patent application Ser. No. 09/350,930, filed Jul. 12, 1999, entitled "ELECTROCHROMIC POLYMERIC SOLID FILMS, MANUFACTURING ELECTROCHROMIC DEVICES USING SUCH FILMS, AND PROCESSES FOR MAKING SUCH SOLID FILMS AND DEVICES" to Desaraju V. Varaprasad et al., or such as is disclosed in U.S. Pat. Nos. 5,668,663; 5,724,187; 5,910,854; and 5,239,405, the entire disclosures of which are hereby incorporated by reference herein. Most preferably, in such laminate-type electrochromic mirror reflective elements, the front substrate comprises a glass plate of thickness less than about 1.6 mm, most preferably about 1.1 mm thickness or lower, and the rear substrate comprises a glass plate of thickness equal to or greater than about 1.6 mm, more preferably greater than about 1.8 mm thickness, most preferably equal to or greater than about 2.0 mm thickness. The rearmost surface of the rear substrate (the fourth surface as known in the mirror art) is reflector coated with a high reflecting metal film such as of aluminum or silver, or an alloy of aluminum or silver. Most preferably, the front-most surface of the rear substrate (the third surface as known in the mirror art) is reflector coated with a high reflecting metal film such as of aluminum or silver, or an alloy of aluminum or silver.

Backing plate element **65** of plano-multiradius reflective element assembly **30** is optionally equipped on its rearmost surface with attachment member **64** to facilitate attachment to the reflector-positioning actuator of the exterior sideview mirror assembly that plano-multiradius reflective element assembly **30** is mounted to. Attachment of plano-multiradius reflective element assembly **30** to the actuator can be by mechanical attachment such as by a tab, clip or fastener, or may be by adhesive attachment such as by a silicone adhesive, a urethane adhesive or a similar adhesive material such as a tape coated on both surfaces with a pressure sensitive adhesive to form a "double-sticky" tape. The exterior sideview mirror assembly, on whose mirror reflector-positioning actuator the plano-multiradius reflective element assembly is mounted, can be a fixedly attached exterior sideview mirror assembly, a break-away exterior sideview mirror assembly and a powerfold exterior sideview mirror assembly, as known in the automotive mirror art.

FIGS. 5A-5H shows various arrangements of multiradius reflective element **55** relative to its adjacent plano reflective element **50** (with demarcation element **65** disposed at their joint). In FIGS. 5A, 5B, 5C, 5E and 5F, plano element **50** is mounted wholly inboard of multiradius element **55**. Thus, in FIGS. 5A, 5B, 5C, 5E and 5F, plano element **50** would be disposed closer to the vehicle body (and hence to the driver) than multiradius element **55** when plano-multiradius reflective element assembly **30** was mounted in an exterior sideview mirror attached to a side of an automobile. Therefore, in FIGS. 5A, 5B, 5C, 5E and 5F, plano element

50 would be mounted inboard relative to the side of the automobile and multiradius element **55** would be mounted outboard relative to the side of the automobile. In general, the location of the multiradius reflective element in the outboard, upper portion of the plano-multiradius reflective element assembly, as in FIGS. **5B** and **5E**, is preferred as this allows the plano portion provide a desired rearward field of view along the side of the vehicle. The configuration as shown in FIG. **5G** (where the multiradius reflective element is along the inboard side of the assembly) is also desirable as this allows the driver view the side of the vehicle (something many drivers desire in order to have a frame of reference for their rearward field of view) while facilitating having a wide field of view for the plano portion.

Unlike trucks, busses and commercial vehicles the size of an exterior sideview mirror assembly suitable for use on an automobile (and especially when the automobile is not towing a trailer or the like) is restricted. Automobiles generally are non-commercial vehicles intended for personal transportation. Automobiles typically carry 5 passengers or less, although minivans and large sports utility vehicles (which are classified herein as automobiles) can have seat accommodation for up to 10 passengers (although accommodation for 7 passengers or less is more common). The tandem mounting of a plano element of unit magnification and a separate auxiliary element onto a common, single backing plate element, and the mounting of this backing plate element onto an actuator of an exterior sideview mirror assembly so that a driver can simultaneously and similarly move the auxiliary element and the plano element so as to position their respective rearward fields of view, and to achieve this within the relatively restricted space available in a standard automobile-sized exterior sideview mirror assembly is an important element of this present invention. By utilizing a plano element of unit magnification in the plano-multiradius reflective element assembly, and by sizing the reflector area of the plano element larger than the reflector area of the multiradius element and, preferably, by sizing the reflector area of the plano element at a sufficiently large size that the rearward field of view provided by the plano element alone meets and satisfies the minimum field of view requirement mandated by an automaker specification and/or a government regulation, the need to provide a safety warning indicia such as "OBJECTS IN MIRROR ARE CLOSER THAN THEY APPEAR" in the plano element and/or in the multiradius element can be obviated. Preferably, the plano element comprises a reflector surface area of a size sufficient, when mounted as part of a plano-multiradius reflective element assembly in a driver-side exterior sideview mirror assembly on an automobile, to provide the driver of the automobile a view of a level road surface extending to the horizon from a line, perpendicular to a longitudinal plane tangent to the driver's side of the automobile at the widest point, extending 8 feet out from the tangent plane 35 feet behind the driver's eyes (at a nominal location appropriate for any 95th percentile male driver or at the driver's eye reference points established in Federal Motor Vehicle Standard No. 104), with the driver seated in the driver's seat and with the driver's seat in the rearmost position. Also, preferably, the aspect ratio of the plano-multiradius reflective element assembly (defined as the ratio of its largest vertical dimension to its largest horizontal dimension, measured with the plano-multiradius reflective element assembly oriented as it would be oriented when mounted in an exterior sideview mirror assembly on an automobile, and with "horizontal" being generally parallel with the road surface the automobile travels on and "verti-

cal" being generally perpendicular to the road surface the automobile travels on) is preferably less than 1, more preferably less than 0.8, most preferably less than 0.6. Further, it is preferable that the multiradius element be disposed outboard (relative to the side of the vehicle and with the plano-multiradius reflective element assembly oriented as it would be when mounted in an exterior sideview mirror assembly on an automobile) on the plano-multiradius reflective element assembly so that the multiradius element is positioned to provide an auxiliary, wide-angle view of a "blind-spot" region in an adjacent sidelane while the more inboard-disposed plano element with unit magnification provides the principal sideview image to the driver.

Also, it is preferable that the principal axis of the rearward field of view of the multiradius element be different from and angled to the principal axis of the rearward field of view of the plano element when both are attached to the backing plate element of the plano-multiradius reflective element assembly and when the plano-multiradius reflective element assembly is mounted and operated in an exterior sideview mirror assembly on an automobile. Preferably, the principal axis of the rearward field of view of the plano element is directed generally parallel to the road that the automobile equipped with the plano-multiradius reflective element assembly is travelling on (i.e. generally parallel to the longitudinal axis of the automobile) so as to provide the driver with a long-distance view of approaching vehicles in the side lane that the plano element views). However, preferably the principal axis of the rearward field of view of the multiradius element of, for example, a door-mounted driver-side (or passenger-side) exterior sideview mirror assembly in which the plano-multiradius reflective element assembly is mounted is directed generally downwardly towards the road surface adjacent to the driver seating location and/or several feet (such as about 1 foot to about 24 feet; more preferably, about 1 foot to about 12 feet; most preferably about 1 foot to about 8 feet in distance) to its rear (in order to capture a field of view of a rear approaching vehicle that is approaching to overtake, or is about to overtake, or is overtaking the automobile equipped with the plano-multiradius reflective element assembly). Thus, preferably, the principal axis of the rearward field of view of the multiradius element is angled and directed generally downwardly with respect to the longitudinal axis of the automobile and thus is at an angle to the principal axis of the rearward field of view of the plano element. For example, multiradius element **155** when attached to surface **173** of backing plate **160** (see FIG. **6B**) would have its principal axis of rearward view as indicated by **180** as in FIG. **6B**, and as such would be canted towards the road surface when mounted in an exterior sideview mirror assembly attached to the side of an automobile. By contrast, plano element **150** when attached to surface **174** of backing plate **160** (see FIG. **6A**) would have a principal axis as indicated by **185** as in FIG. **6A** and, as such, would be generally parallel to the road surface when mounted in an exterior sideview mirror assembly attached to the side of an automobile. Having the multiradius element canted somewhat downwards towards the road surface assists visual detection by the driver of overtaking vehicles in the traditional "blind-spot" in the adjacent side lane. The angle that the multiradius element is angled on the backing plate element of the plano-multiradius reflective element assembly relative to the plane of the plano reflective element will vary from automobile model to model, but generally is preferred to be in the about 1° to about 10° range; about 2° to about 8° range more preferred; and about 3° to about 6° range most preferred. In order to

15

conveniently achieve an angling of the multiradius portion with respect to the plano portion (and preferably a downward angling), the portion of the backing plate element that the multiradius reflective element is attached to can be angled relative to the adjacent portion of the backing plate element that the plano reflective portion is attached to. Thus, and referring to FIG. 6, plano-multiradius reflective element assembly 130 includes a molded polymeric backing plate element 160 comprising a generally flat portion 162 (between BB and CC in FIG. 6) and an adjacent curved portion 161 (between AA and BB). As indicated by 190 and 195, portion AA to BB of backing plate element 160 is generally angled to portion BB to CC of backing plate 160. Preferably, the portion of backing plate element 160 to which the auxiliary reflective element attaches is angled towards the front (compared to the angling of plano reflective element) of an automobile equipped with the plano-auxiliary reflective element assembly of the present invention. FIG. 6 is a view of plano-multiradius reflective element assembly 130 as it would appear from above the vehicle as it would be orientated in use (with portion 162 closer to the driver than portion 161). The wall section, section XX in FIG. 6, taken through section 162 of backing plate element 160 is of substantially constant dimension (as illustrated in FIG. 6A) whereas the wall section, section YY in FIG. 6B, taken through section 161 of backing plate element 160 is of varying dimension and is angled. Plano reflective element 150 and multiradius reflective element 155 (for example, plano element 150 can comprise an electrochromic mirror element and multiradius element 155 can comprise a chrome coated glass reflector) are attached to portions 162 and 161, respectively. By being supported on the angled face 173 (see FIG. 6B) of portion 161, the principal viewing axis of multiradius reflector element 155 is angled downwards towards the road surface, as compared to the more horizontal-viewing principal viewing axis of plano element 150, when plano-multiradius reflective element 130 is mounted in an exterior sideview mirror assembly on an automobile. Demarcation element 165 is preferably molded in the same molding tool as is used to mold backing plate element 160, and so demarcation element 165 is formed as an integral part of backing plate element 160, forming a wall thereof that partitions the surface of backing plate element 160 into a region for receiving the plano reflective element 150 and a region for receiving the auxiliary reflective element 155. Also, end-caps 170 and 171 are optionally provided. Plano reflective element 150 can attach into the cavity formed between demarcation element 165 and end-cap 171; multiradius reflective element 155 can attach into the cavity formed between demarcation element 165 and end-cap 170. Note that the portion of the backing plate element where the wide-angle optic multiradius element attaches can have a thicker wall thickness than that of the portion of the backing plate element where the unit magnification optic element attaches in order to allow for the angling of the multiradius element downwardly relative to the angle of the plano element, as illustrated in FIGS. 6A-B. As illustrated in FIGS. 6A-B, the angle downwards to the longitudinal axis of the vehicle of the multiradius element can generally be set by an angling of a surface of the backing plate element in order to ensure that the principal axis of the rearward field of view of the plano element is directed generally parallel to the longitudinal axis of an automobile equipped with the plano-multiradius reflective element assembly and that the principal axis of the rearward field of view of the multiradius element is directed generally at an angle downwards to the longitudinal axis of the automobile.

16

Note that the provision of the plano-multiradius reflective element assembly of this invention as a unitary module has manufacturing advantages, particularly for exterior sideview mirror assembly manufacturers who can procure a plano-multiradius reflective element assembly module from a mirror reflector supplier and then mount the plano-multiradius reflective element assembly module onto an actuator.

Referring to FIG. 7, a third embodiment 230 of a plano-multiradius reflective element assembly is illustrated. Plano-multiradius reflective element assembly 230 includes a plano reflective element 250 and a separate multiradius reflective element assembly 255, both individually attached to a backing plate element, and with demarcation element 265 disposed at their joint. Plano-multiradius reflective element assembly 230 is about 8.5 inches wide and about 4.25 inches tall (aspect ratio of 0.5), at their largest dimension. Shown as the shaded triangle 240 in plano reflective element 250 is the image of a triangular target object set about 35 feet rearward and of width about 8 feet and of height of about 4.1 feet as would be seen were plano-multiradius reflective element assembly 230 mounted in a driver-side exterior sideview mirror assembly in an automobile such as a sports utility vehicle. In general, it is desirable that the plano reflective element be dimensioned and configured so as to have its rearward field of view capture an image (that is visible, by reflection in the plano reflective element, to a driver seated in the driver's seat in an automobile to which is attached an exterior sideview mirror assembly equipped with the plano-auxiliary reflective element assembly according to this present invention) of a triangular shaped target located about 35 feet rearward of the driver seating location, extending about 8 feet out from the plane defined by the side of the automobile and reaching a height of between about 4 feet and about 5 feet from the road surface at that location 35 feet rearward of the automobile. The total field of view rearwardly of the vehicle of plano-multiradius reflective element assembly 230 (which is a combination of the field of view of plano reflective element 250 and of the auxiliary multiradius reflective element 255) preferably generally subtends an angle of at least about 30° (and more preferably, generally subtends an angle of at least about 35° and most preferably, generally subtends an angle of at least about 40°) with respect to the side of an automobile to which is attached an exterior sideview mirror assembly equipped with plano-multiradius reflective element assembly 230.

Referring to FIG. 8, another embodiment 310 of the plano-auxiliary reflective element assembly of the present invention is illustrated. Plano-auxiliary reflective element assembly 310 includes a first reflective element 312 and a second or auxiliary, separate reflective element 314 which are together supported in a frame element assembly 316. As will be more fully described below, frame element assembly 316 is adapted such that when reflective elements 312 and 314 are placed, or otherwise positioned, in frame element assembly 316, the angular orientation of each reflective element is pre-established such that during assembly, the assembler need simply place the reflective elements in frame element assembly 316.

In the illustrated embodiment, frame element assembly 316 includes a frame 318 with a forward facing open portion 318a (FIG. 9) (and thus when frame element assembly 316 is mounted in a vehicle-mounted exterior sideview mirror assembly, the forward facing open portion (318a) is facing to the front of the vehicle) through which a reflective element subassembly 317a, which includes reflective ele-

17

ment **312**, is positioned in frame element assembly **316** and a rearward facing open portion **318b** (FIG. **8**) (which faces the rear of the vehicle when frame element assembly **316** is mounted in a vehicle mounted exterior sideview mirror assembly) in which a second reflective element subassembly **317b**, which includes reflective element **314**, is positioned in frame element assembly **316**. Frame **318** preferably comprises a molded member formed from a plastic material, such as a reinforced nylon.

In preferred form, first reflective element **312** comprises a plano reflective element **350**, such as a flat reflector coated glass substrate, with a reflective surface through which the angular height and width of an image of an object is equal to the angular height and width of the object when viewed to the same distance (except for flaws that do not exceed normal manufacturing tolerances) so as to have a unit magnification. Similar to the previous embodiment, plano reflective element **350** may comprise a conventional fixed reflectance reflective element or may comprise a variable reflectance reflective element whose reflectivity is electrically adjustable, as is known in the art. For example, plano reflective element **350** may comprise a flat glass substrate coated with metallic reflector coating, such as a chromium coating, titanium coating, rhodium coating, metal alloy coating, nickel alloy coating, silver coating, aluminum coating, or any alloy or composition of these metal reflectors. For further details of plano reflective element **350**, reference is made to the previous embodiments.

In the illustrated embodiment, reflective element **312** comprises an electrochromic reflective element and includes a first substrate **312a** and a second substrate **312b** with an electrochromic medium **312c** disposed between first and second substrates **312a**, **312b**. Such suitable electrochromic media include, for example, a solid polymer matrix electrochromic medium as noted in reference to the previous embodiments. Electrical connectors **320a** and **320b** are coupled to the electrochromic medium **312c** to provide a potential across the electrochromic medium which induces the electrochromic medium to darken, as is known in the art. In the illustrated embodiment, reflective element subassembly **317a** also includes an optional heater pad **322**, which is disposed behind reflective element **312**, and a vibration reducing element, such as a foam pad **326**, positioned behind heater pad **322**, which absorbs vibration of reflective element **312**.

Referring again to FIG. **9**, frame **318** is adapted to receive and support reflective element subassembly **317a**, which is mounted to frame **318** by a backing plate **324**, such as a plastic backing plate. In the illustrated embodiment, backing plate **324** mounts to the inner perimeter portion of frame **318** using conventional techniques, such as by adhesive bonding, heatstaking, snap-fit coupling, welding, or the like, to form part of frame element assembly **316**. Alternatively, backing plate **324** may mount onto foam pad **326**, for example, by an adhesive attachment, such as double sided sticky tape. In which case, reflective element **312** may be mounted to an inner surface of frame **318**, such as by an adhesive attachment, including for example a silicone adhesive, with heater pad **322** mounted to reflective element **312**, such as by an adhesive attachment, and foam pad **326** mounted to heater pad **322**, such as by an adhesive attachment including, for example, double-sided sticky tape.

Frame element assembly **316** mounts reflective element assembly **310** in the mirror casing and preferably on an actuator, such as an electric actuator, which permits adjustment to the orientation of reflective element assembly **310** about one or more axis. Examples of suitable actuators are

18

described in U.S. Pat. Nos. 5,900,999; 5,986,364; 6,132,052; 6,037,689; and 6,094,027 and copending applications Ser. No. 09/277,632, filed Mar. 26, 1999, now U.S. Pat. No. 6,229,226, and Ser. No. 09/408,867, filed Sep. 29, 1999, now U.S. Pat. No. 6,243,218, which are incorporated herein by reference in their entireties. Optionally and preferably, backing plate **324** is adapted to engage or be engaged by the actuator for repositioning of plano-auxiliary reflective element assembly **310** about one or more axes. In this manner, the orientation of both reflective element **312** and reflective element **314** are simultaneously adjusted by the actuator. As best seen in FIG. **9**, forward facing side **324a** of backing plate **324** includes mounting structures **324b** which are engaged by the actuator to thereby mount reflective element assembly **310** in the mirror casing.

Referring again to FIG. **8**, frame **318** is a unitary frame and includes a first bezel portion **330** which extends around reflective element **312** and a second bezel portion **332** which extends around reflective element **314** to provide styling utility as well as functional utility. In this manner, a portion of forward facing side of frame **318** forms a support surface for reflective element **312**, while a portion of rearward facing side of frame **318** forms first bezel portion **330**. Similarly, another portion of the rearward facing side of frame provides support for reflective element **314** and also provides bezel portion **332**. In addition, a portion of frame **318** forms a demarcation element at the juncture of reflective elements **312** and **314**. In the illustrated embodiment, the demarcation element is formed by a section or portion of bezel portion **330**, which will be described in greater detail in reference to bezel portion **330**. Thus, frame element assembly **316** provides a support function, a positioning function, including an angling function, while also serving to provide styling utility and a demarcation function.

Second reflective element **314** comprises a radiused reflective element and, more preferably, a multiradiused reflective element **355** having a multiradiused curvature. For example, the radii of curvature of reflective element **314** may range from about 4000 mm to about 100 mm and, preferably, range from about 3000 mm to about 150 mm, and, most preferably, range from about 2000 mm to about 200 mm. In addition, reflective element **314** may comprise a fixed reflectance reflective element or may comprise a variable reflectance reflective element whose reflectivity is electrically adjustable. Preferably, reflective elements **312** and **314** include glass substrates, with at least the outer surface of each reflective element comprising glass. However, metalized plastic reflectors may also be used which is especially suitable for reflective element **314**. In which case, the reflective element (**314**) would be especially suitable for molding in or along with frame **318**, with the preformed metalized substrate forming reflective element **314** being placed into the mold forming frame **318**. For further details of other suitable reflective elements, reference is made to the previous embodiments. In addition to reflective element **314**, reflective element subassembly **317b** includes a vibration reducing element, such as a foam pad **314a**, which is positioned behind reflective element **314**. Similar to reflective element **312**, foam pad **314a** is attached to reflective element **314** by an adhesive attachment, such as a double-sided sticky tape and, similarly, is attached to frame **318** as will be more fully described below.

As noted above, frame **318** includes a first bezel portion **330** and a second bezel portion **332**. In addition, frame **318** includes an auxiliary support element **320** that provides a mounting surface or support surface for reflective element subassembly **317b**. As best seen in FIGS. **9** and **10**, support

element 320 includes a recessed support surface 328 which is angled to provide an angled support surface for reflective element subassembly 317b. Thus, when reflective subassembly 317b is positioned on and mounted on support surface 328, such as by an adhesive attachment between foam pad 314a and support surface 328, the orientation of reflective element 314 is established by the angle of the support surface. Optionally, support element 320 includes gussets 321a and 321b which project forwardly from the forward facing side of frame 318 to thereby reinforce support surface 328.

Referring to FIG. 8, first bezel portion 330 includes an upper portion 330a, two side portions 330b and 330c, and a lower portion 330d. Side portion 330b forms an acute angle with respect to the lower portion 330d and an obtuse angle with respect to upper portion 330a and together with upper portion 330a, side portion 330c, and lower portion 330d form a perimeter around reflective element 312 to thereby form a styling feature. Second bezel portion 332 extends outwardly from upper portion 330a and downwardly to lower portion 330d of first perimeter portion 330 and together with side portion 330b forms a perimeter around second reflective element 314. Support element 320 extends behind and between side portion 330b and second bezel portion 332 so that reflective element 314 is recessed behind side portion 330b and bezel portion 332.

As best seen in FIG. 10, upper portion 330a, side portions 330b and 330c, and lower portion 330d are substantially coplanar and together define an outer surface below which reflective element 312 is recessed when reflective element 312 is mounted in frame 318. In contrast, perimeter portion 332 is angled forwardly with respect to the plane in which upper portion 330a, side portions 330b and 330c, and lower portion 330d lie. It should be understood that the terms "forwardly", "rearwardly" and "downwardly", are used in reference to when the mirror system is mounted in an automobile. Therefore, "forwardly" is a direction heading toward the front of the automobile, "rearwardly" is a direction heading to the rear of the automobile, "outwardly" is a direction away from the side of the vehicle on which the mirror assembly is mounted, and "downwardly" is a direction heading toward the surface on which the vehicle is positioned (such as a ground or road surface). Similarly as noted above, reflective element 314 is recessed below an outer surface of perimeter portion 332 and also below the outer surface of side portion 330b when mounted in frame 318.

As would be understood from FIGS. 9-11, support surface 328 is also angled forwardly with respect to back plate 324 and/or reflective element 312 when frame element assembly 316 is mounted in an automobile mounted exterior sideview mirror system. In addition, support surface 328 is also angled or tilted downwardly with respect to reflective element 312 and/or backing plate 324 such that when reflective element 314 is supported on support surface 328, reflective element 314 provides an increased field of view extending laterally or outwardly from the longitudinal axis of the automobile and also downwardly of the longitudinal axis of the automobile.

Referring to FIGS. 13 and 14, support surface 328 is configured such that reflective element 314 is tilted forwardly at an angle α with respect to the X-axis of reflective element 312. In one form, angle α is in a range of about 0.75° to about 5°. In another form, angle α is in a range of about 1° to about 3°. In yet another form, angle α is in a range of about 1.25° to about 2.5°. Reflective element 314 is also tilted downwardly with respect to the Y-axis of

reflective element 312 at an angle β . In one form, angle β is in a range of about 0.75° to about 5°. In another form, angle β is in a range of about 1.5° to about 3.5°. In yet another form, angle β is in a range of about 2° to about 3°. With the tilted orientation of reflective element 314, reflective element 314 provides a field of view with a principal axis that sweeps outwardly and downwardly with respect to the principal axis of the field of view of reflective element 312.

In the illustrated embodiment, support surface 328 is provided by a plate member 321. Plate member 321 may comprise a solid plate member or a foraminous plate member. In the illustrated embodiment, plate member 321 is integrally formed with perimeter portions 330 and 332 during the molding process of frame 318. As previously noted, frame 318 includes a rearwardly facing opening 318b through which reflective element 314 is inserted for placement on support surface 328. For example, reflective element 314 may be positioned in frame 318 on support surface 328 during the molding process of frame 318, such as by insert molding, or may be inserted into frame 318 before the plastic material forming frame 318 is fully cured and is still pliable. In which case, reflective element subassembly 317b is mounted to auxiliary support 320 by an adhesive attachment or a mechanical attachment. Alternatively, support surface 328 may be formed by peripheral flange or a frame. In this manner, reflective element subassembly 317b may be placed in frame 318 from its forward facing side.

Referring to FIG. 14, when reflective element assembly 310 is mounted in a vehicle reflective element 312 has a field of view 360 which forms an angle A with respect to the longitudinal center line of the vehicle in a range of about 8° to about 20°. In another form, angle A is in a range of about 10° to about 18°. In yet another form, angle A is in a range of about 12° to about 16°. Similarly, reflective element 314 has a field of view 362 which forms an angle C in range of about 15° to about 50°. In another form, angle C is in a range of about 15° to about 35°. In yet another form, angle C is in a range of about 15° to about 25°. Consequently, the overall field of view of reflective elements 312 and 314 extends over an angle B, which ranges from about 8° to about 50° in one form, about 10° to about 35° in another form, and about 12° to about 25° in yet another form. Furthermore, field of views 360 and 362 overlap over a range having angle D in a range of about 20° to about 2°, or in a range of about 15° to about 5°. In another form, angle D is in a range of about 10° to about 8°.

From the foregoing, it can be appreciated that reflective elements 312 and 314 provide a wider field of view than a wholly planar rearview mirror element that fully accommodates an equivalent frame having similar dimensions. In addition, because reflective elements 312 and 314 have overlapping field of views, an image in the field of view of reflective element 314 will transition or move between the reflective elements and appear in both reflective elements during the transition to thereby enable the driver of the automobile to view or be conscious of the object continuously. In the illustrated embodiment, reflective element 314 is positioned in an outboard position relative to reflective element 312; therefore, when a vehicle or object that is approaching the automobile from the rear and to some extent from the side, the image of the approaching object will first appear in reflective element 312, then appear in both reflective elements 314 and 312, and then move to reflective element 314 so that the driver will be initially aware of the approaching object when its image first appears in reflective element 312 and continue to be aware of the object as it moves closer to the automobile, thus increasing the range of

21

viewing of the driver. Since the image transitions smoothly from reflective element 312 to reflective element 314, the driver's awareness of the object is continuous and, further, the driver is not distracted from sudden transitions that often occur with conventional spotter mirrors. Typically, when an object "falls" or "drops" out, a driver's consciousness of the object reduces significantly, if not ceases, which is one of the causes of many automobile blind spot accidents. Hence, when combined with the field of view of an interior rearview mirror system, the present invention reduces, if not eliminates, an automobile's blind spot. For further discussion of blind spots in vehicle rearview mirror systems, reference is made to copending U.S. provisional application entitled VEHICULAR REARVIEW MIRROR SYSTEM, Ser. No. 60/252,149, filed Nov. 20, 2000 by Robert E. Schnell, David K. Willmore, and Richard J. Weber (Attorney Docket DON01 P-840), which is herein incorporated by reference in its entirety. Thus, the plano-auxiliary reflective element assembly provides a seamless rearvision function whereby the image of a side approaching/side overtaking other vehicle is substantially seamlessly maintained as the image of the overtaking or approaching vehicle transitions from being principally and substantially viewed by the driver of the vehicle (the vehicle mounted with the mirror system of the present invention) in the plano reflective element to be seen in the auxiliary reflective element.

Referring to FIG. 15, the numeral 410 generally designates yet another embodiment of an automobile exterior sideview mirror system of the present invention. Exterior sideview mirror system 410 includes a housing 412, a first reflective element 414, and a second or auxiliary, separate reflective element 416, which together provide an increase field of view over conventional planar reflectors mounted in a frame of equivalent dimensions to the combined lateral dimensions of reflective element 414 and 416.

Housing 412 includes a mirror casing 417 and a sail 418, which mounts casing 412 to a side of an automobile. Though illustrated as a fixed mounting arrangement, it should be understood that mirror system 410, like the previous embodiments, may comprise a break-away mirror system or a powerfold mirror system.

In the illustrated embodiment, reflective element 414 comprises a plano reflective element having a unit magnification, similar to the plano reflective elements described in reference to the previous embodiments. Reflective element 416 preferably comprises a wide-angle reflector, such as a convex or aspheric reflector, and may include a multiradiused curvature. For further description of suitable reflectors, reference is made to the previous embodiment.

In the illustrated embodiment, reflective element 416 is mounted in an outboard position relative to reflective element 414 and is fixedly mounted to bezel 420 of mirror casing 417. In addition, reflective element 416 is preferably angled downwardly and forwardly relative to first reflective element 414 when mirror system 410 is mounted to an automobile to thereby increase the field of view of mirror system 410. Optionally and preferably, reflective element 416 is detachably mounted to bezel 420, such as by mechanical fasteners, including clips, so that reflective element 416 can be removed, such as for replacement.

Reflective element 414 preferably comprises an independently positionable reflective element and is mounted by a backing member, such as a backing plate, to an actuator, which provides multi-axis positioning of reflective element 414. In this manner, reflective element 414 and reflective

22

element 416 are separately and independently mounted in housing 412. In addition, reflective element 414 optionally extends behind reflective element 416 in order to maintain the overlap of the field of views of reflective elements 414 and 416 even when reflective element 414 is moved by the actuator. Similar to the previous embodiment, when an object moves toward the automobile, in which mirror system 410 is mounted, from the rear of the automobile or laterally with respect to the automobile, the image of the object will appear initially in reflective element 414. As the object moves closer to the automobile, the image of the object will move from reflective element 414 to reflective element 416 such that when the image transitions between reflective element 414 and reflective element 416, the image will appear in both reflective elements.

Also, although it is preferable to utilize a multiradius or compound curvature reflective element, such as an aspherical element or a compound curvature element, for the second or auxiliary mirror element adjacent the plano or first reflective element (as this enables least discontinuity in image at the joint between the adjacent elements of the assembly), a spherical reflective element (that has substantially only one radius of curvature and, as such, is a section from a sphere) can optionally be used adjacent the plano reflective element instead of, or in addition to, the multiradius reflective element. Also, a plano auxiliary mirror such as a flat mirrored substrate can be used, less preferably, as a substitute for a multiradius reflective element in those embodiments where the auxiliary reflective element is angled relative to the plane of the principal, plano reflective element so as to view a blind spot region of the principal plano element. Also, the plano-multiradius reflective element assembly can optionally be fixedly attached to an exterior sideview mirror assembly housing that is not movable, or, alternately, the exterior sideview mirror assembly housing to which the plano-multiradius reflective element assembly is fixedly attached can itself be actuated to move, such as by motor action, so that by moving the exterior sideview mirror assembly housing, the field of rearward view of the plano-multiradius reflective element assembly fixedly attached thereto can correspondingly move and be repositioned to suit the field of view need of a particular driver seated in the automobile cabin.

The above description is considered that of the preferred embodiments only. Modification of the invention will occur to those skilled in the art and to those who make or use the invention. Therefore, it is understood that the embodiments shown in the drawings and described above are merely for illustrative purposes and are not intended to limit the scope of the invention, which is defined in the following claims as interpreted according to the principles of patent law, including the doctrine of equivalents.

We claim:

1. An automobile exterior sideview mirror system comprising:

an exterior sideview mirror assembly adapted for attachment to a side of an automobile;

said exterior sideview mirror assembly including a mirror casing, a reflective element assembly, and an actuator; and

said reflective element assembly including a frame element assembly, a first reflective element having unit magnification, and a second reflective element having a multiradiused curvature, said frame element assembly mounting said first reflective element and said second reflective element in said mirror casing and being

23

adapted to mount to said actuator, said actuator adjusting the orientation or said reflective element assembly, said frame element assembly including a first open portion and a second open portion, said first open portion receiving said first reflective element, said second open portion receiving said second reflective element, said second open portion comprising a rearward facing open portion when said mirror assembly is mounted to the automobile, and said first open portion comprising a forwardly facing open portion when said mirror assembly is mounted to the automobile, said first reflective element having a first rearward field of view with a first principal axis, said second reflective element having a second rearward field of view with a second principal axis, and said frame element assembly angling said second principal axis outwardly and downwardly with respect to said first principal axis.

2. The exterior sideview mirror system of claim 1, wherein

said first reflective element comprises a plano reflective element having said unit magnification, and said second reflective element comprises a multiradius reflective element having said multiradiused curvature.

3. The exterior sideview mirror system of claim 2, wherein said plano reflective element and said multiradius reflective element are adjacently attached to said frame element assembly at a joint, and wherein said reflective element assembly includes a demarcation element, said demarcation element disposed at said joint to form a demarcation between said plano reflective element and said multiradius reflective element, said demarcation element having a portion visible to a driver of the automobile.

4. The exterior sideview mirror system of claim 3, wherein said demarcation element is dark colored.

5. The exterior sideview mirror system of claim 4, wherein said frame element assembly includes a first bezel portion extending around said plano reflective element, said demarcation element comprising a segment of said first bezel portion.

6. The exterior sideview mirror system of claim 5, wherein said multiradiused reflective element comprises a bent glass substrate with radii of curvature in the range of about 4000 mm to about 100 mm.

7. The exterior sideview mirror system of claim 2, wherein said frame element assembly includes a frame, said first and second reflective elements being mounted in said frame.

8. The exterior sideview mirror system of claim 7, wherein said multiradiused reflective element is mounted to said frame at an outboard position, and said plano reflective element is positioned adjacent said multiradiused reflective element and at an inboard position with respect to said multiradiused reflective element when said exterior sideview mirror assembly is mounted to the automobile.

9. The exterior sideview mirror system of claim 8, wherein said plano reflective element is mounted to said frame by a backing plate.

10. The exterior sideview mirror system of claim 9, wherein said backing plate is adapted to mount to said actuator.

11. The exterior sideview mirror system of claim 10, wherein said actuator comprises an electrical actuator.

12. The exterior sideview mirror system of claim 9, wherein said backing plate is attached to one side of said first reflective element and said frame by one of an adhesive attachment, a welded attachment, and a mechanical attachment.

24

13. The exterior sideview mirror system of claim 12, wherein an opposed side of said frame forms a bezel around said plano reflective element.

14. The exterior sideview mirror system of claim 7, wherein said plano reflective element and said multiradiused reflective element are adjacently attached to said frame, said frame including a first perimeter portion and a second perimeter portion, said first perimeter portion extending around said plano reflective element, and said second perimeter portion extending around said multiradiused reflective element.

15. The exterior sideview mirror system of claim 14, wherein a side portion of said first perimeter portion of said frame provides a demarcation between said plano reflective element and said multiradiused reflective element.

16. The exterior sideview mirror system of claim 14, wherein said second perimeter portion is angled downwardly and forwardly with respect to said first perimeter portion when said mirror assembly is mounted to the automobile.

17. The exterior sideview mirror system of claim 7, wherein said multiradiused reflective element is attached to said frame by at least one of an adhesive attachment and a mechanical attachment and a mechanical attachment.

18. The exterior sideview mirror system of claim 2, wherein at least one of said plano reflective element and said multiradiused reflective element comprises a variable reflectance reflective element.

19. The exterior sideview mirror system of claim 18, wherein each of said plano reflective element and said multiradiused reflective element comprises a variable reflectance reflective element.

20. The exterior sideview mirror system of claim 2, wherein said plano reflective element comprises an electrochromic reflective element.

21. The exterior sideview mirror system of claim 1, wherein said exterior sideview mirror assembly comprises a fixedly attached exterior sideview mirror assembly.

22. The exterior sideview mirror system of claim 1, wherein said exterior sideview mirror assembly comprises a break-away exterior sideview mirror assembly.

23. The exterior sideview mirror system of claim 1, wherein said exterior sideview mirror assembly comprises a powerfold exterior sideview mirror assembly.

24. The exterior sideview mirror system of claim 1, wherein said second principal axis is angled downwardly from said first principal axis at an angle in a range of approximately 0.75° to about 5°.

25. The exterior sideview mirror system of claim 24, wherein said second principal axis is angled downwardly from said first principal axis at an angle in a range of about 1.5° to about 3.5°.

26. The exterior sideview mirror system of claim 25, wherein said second principal axis is angled downwardly from said first principal axis at an angle in a range of about 2° to about 3°.

27. The exterior sideview mirror system of claim 1, wherein said second principal axis is directed generally outwardly and downwardly with respect to a longitudinal axis of an automobile when said mirror assembly is mounted to the automobile.

28. The exterior sideview mirror system of claim 1, wherein said frame element assembly includes a support surface for said second reflective element, said support surface angling said second principal axis of said second reflective element.

29. The exterior sideview mirror system of claim 1, wherein said second reflective element is outboard of said first reflective element.

25

30. The exterior sideview mirror system of claim 1, wherein at least one of said reflective elements comprises a variable reflectance reflective element.

31. The exterior sideview mirror system of claim 1, wherein at least one of said first reflective element and said second reflective element comprises an electro-optic reflective element.

32. An automobile exterior sideview mirror system comprising:

an exterior sideview mirror assembly adapted for attachment to a side of an automobile; and

said exterior sideview mirror assembly including an actuator and a reflective element assembly, said reflective element assembly having a frame element assembly, a first reflective element, and a second reflective element, said first reflective element comprising a plano reflective element, said second reflective element comprising a multiradiused reflective element having a multiradiused curvature, said frame element assembly being adapted to mount to said actuator and including a frame and a support surface for said second reflective element said frame including a forward facing open portion and a rearward facing open portion when said mirror assembly is mounted to the automobile, said first forward facing open portion receiving said first reflective element, and said rearward facing open portion receiving said second reflective element, said actuator adjusting an orientation of said reflective element assembly, said support surface orienting said second reflective element downwardly and forwardly of said first reflective element when said mirror assembly is mounted to the automobile whereby said second reflective element provides a viewing range which spans outwardly and downwardly with respect to the automobile to thereby provide an increased field of view for said exterior sideview mirror assembly.

33. The exterior sideview mirror system of claim 32, wherein said plano reflective element includes a rearward field of view having a principal axis different from and angled to a principal axis of the rearward field of view of said multiradiused reflective element when mounted in said exterior sideview mirror assembly.

34. The exterior sideview mirror system of claim 33, wherein said principal axis of the rearward field of view of said multiradiused reflective element is directed generally outwardly and downwardly with respect to a longitudinal axis of the automobile.

35. The exterior sideview mirror system of claim 34, wherein said principal axis of the rearward field of said multiradiused reflective element forms a downward angle with respect to the longitudinal axis of the automobile in the range from about 0.75° to about 5°.

36. The exterior sideview mirror system of claim 35, wherein said downward angle is in a range from about 1.5° to about 3.5°.

37. The exterior sideview mirror system of claim 36, wherein said downward angle is in a range of about 2° to about 3°.

38. The exterior sideview mirror system of claim 34, wherein said principal axis of said multiradiused reflective

26

element forms an outward angle with respect to the longitudinal axis of the automobile in a range of about 0.75° to about 5°.

39. The exterior mirror system of claim 38, wherein said outward angle is in range of about 1° to about 3°.

40. The exterior sideview mirror system of claim 39, wherein said outward angle is in a range of about 1.25° to about 2.5°.

41. The exterior sideview mirror system of claim 32, wherein said first reflective element has a first principal axis and said second reflective element has a second principal axis, said second principal axis is angled outwardly from said first principal axis at an angle in a range of about 0.75° to about 5°.

42. The exterior sideview mirror system of claim 41, wherein said second principal axis is angled outwardly from said first principal axis at an angle in a range of about 1° to about 3°.

43. The exterior sideview mirror system of claim 42, wherein said second principal axis is angled outwardly from said first principal axis at an angle in a range of about 1.25° to about 2.5°.

44. The exterior sideview mirror system of claim 32, wherein said frame forms a bezel portion around said first reflective element.

45. The exterior sideview mirror system of claim 44, wherein said frame forms a bezel portion around said second reflective element.

46. The exterior sideview mirror system of claim 32, wherein a portion of said frame forms a demarcation between said first and second reflective elements.

47. The exterior sideview mirror system of claim 32, wherein said support surface comprises a plate element.

48. The exterior sideview mirror system of claim 47, wherein said plate element comprises a solid plate element.

49. The exterior sideview mirror system of claim 47, wherein said plate element comprises foraminous plate element.

50. The exterior sideview mirror system of claim 32, wherein said frame includes a first bezel portion and a second bezel portion, said first bezel portion extending around said first reflective element, and said second bezel portion extending around said second reflective element.

51. The exterior sideview mirror system of claim 50, wherein said second bezel portion is angled forwardly with respect to said first bezel portion when said exterior sideview mirror assembly is mounted to the side of an automobile.

52. The exterior sideview mirror system of claim 32, wherein said first reflective has a substantially unit magnification.

53. The exterior sideview mirror system of claim 32, wherein a rearward facing side of said forward facing open portion defining a bezel around said first reflective element.

54. The exterior sideview mirror system of claim 53, wherein said frame includes a bezel around said second reflective element at said rearward facing open portion.

* * * * *

UNITED STATES PATENT AND TRADEMARK OFFICE
CERTIFICATE OF CORRECTION

PATENT NO. : 6,717,712 B2
APPLICATION NO. : 09/745172
DATED : April 6, 2004
INVENTOR(S) : Niall R. Lynam, John O. Lindahl and Hahns Joachim Fuchs

Page 1 of 2

It is certified that error appears in the above-identified patent and that said Letters Patent is hereby corrected as shown below:

Title page Item (75) Inventors:

“Hahns Yoachim Fuchs” should be --**Hahns Joachim Fuchs**--

Column 12:

Line 5, “electrooptic” should be --electro-optic--

Column 23:

Line 2, Claim 1, “or” should be --of--

Line 3, Claim 1, Insert --first reflective element having a first rearward field of view with a first principal axis, said-- after “said”

Line 23, Claim 2, “multiradiused” should be --multiradius--

Line 37, Claim 5, “piano” should be --plano--

Line 49, Claim 8, “piano” should be --plano--

Line 53, Claim 8, “the” should be --an--

Column 24:

Line 9, Claim 14, “piano” should be --plano--

Line 19, Claim 16, “the” should be --an--

Line 24, Claim 17, Delete --and a mechanical attachment-- in the second occurrence

Line 55, Claim 26, “am” should be --an--

Line 59, Claim 27, “wit” should be --with--

Column 25:

Line 22, Claim 32, Insert --,-- after “element”

Line 24, Claim 32, “the” should be --an--

Line 32, Claim 32, “the” should be --an--

Line 60, Claim 38, “mulliradiused” should be --multiradiused--

UNITED STATES PATENT AND TRADEMARK OFFICE
CERTIFICATE OF CORRECTION

PATENT NO. : 6,717,712 B2
APPLICATION NO. : 09/745172
DATED : April 6, 2004
INVENTOR(S) : Niall R. Lynam, John O. Lindahl and Hahns Joachim Fuchs

Page 2 of 2

It is certified that error appears in the above-identified patent and that said Letters Patent is hereby corrected as shown below:

Column 26:

Line 4, Claim 39, Insert --sideview-- after "exterior"

Line 5, Claim 39, Insert --a-- after "in"

Line 37, Claim 49, Insert --a-- after "comprises"

Line 47, Claim 21, "the" should be --a--

Signed and Sealed this

Seventeenth Day of June, 2008

A handwritten signature in black ink that reads "Jon W. Dudas". The signature is written in a cursive style with a large, looped initial "J".

JON W. DUDAS
Director of the United States Patent and Trademark Office

Electronic Acknowledgement Receipt

EFS ID:	18488722
Application Number:	14054004
International Application Number:	
Confirmation Number:	4390
Title of Invention:	EXTENDED FIELD OF VIEW EXTERIOR MIRROR ELEMENT FOR VEHICLE
First Named Inventor/Applicant Name:	Niall R. Lynam
Customer Number:	15671
Filer:	Timothy A. Flory/Amanda Sytsma
Filer Authorized By:	Timothy A. Flory
Attorney Docket Number:	DON09 P-2194
Receipt Date:	17-MAR-2014
Filing Date:	15-OCT-2013
Time Stamp:	10:12:35
Application Type:	Utility under 35 USC 111(a)

Payment information:

Submitted with Payment	no
------------------------	----

File Listing:

Document Number	Document Description	File Name	File Size(Bytes)/ Message Digest	Multi Part /.zip	Pages (if appl.)
1	Transmittal Letter	TransmittalForm.pdf	117667 114e6ae4a63b83cbbd7954473a7c8d9c49e14106	no	1

Warnings:

Information:

2	Amendment/Req. Reconsideration-After Non-Final Reject	ResponseA.pdf	35789 <small>4d8935a29d99bc05b1ff4925dbd67eab535 efdb6</small>	no	6
Warnings:					
Information:					
3	Affidavit-Rule 131-pre-AIA (FTI) ONLY	LynamDeclarationandExhibits. pdf	13565346 <small>40df1146bc23dc27105676a8ce0d8e4e257 a6987</small>	no	156
Warnings:					
Information:					
Total Files Size (in bytes):			13718802		
<p>This Acknowledgement Receipt evidences receipt on the noted date by the USPTO of the indicated documents, characterized by the applicant, and including page counts, where applicable. It serves as evidence of receipt similar to a Post Card, as described in MPEP 503.</p> <p><u>New Applications Under 35 U.S.C. 111</u> If a new application is being filed and the application includes the necessary components for a filing date (see 37 CFR 1.53(b)-(d) and MPEP 506), a Filing Receipt (37 CFR 1.54) will be issued in due course and the date shown on this Acknowledgement Receipt will establish the filing date of the application.</p> <p><u>National Stage of an International Application under 35 U.S.C. 371</u> If a timely submission to enter the national stage of an international application is compliant with the conditions of 35 U.S.C. 371 and other applicable requirements a Form PCT/DO/EO/903 indicating acceptance of the application as a national stage submission under 35 U.S.C. 371 will be issued in addition to the Filing Receipt, in due course.</p> <p><u>New International Application Filed with the USPTO as a Receiving Office</u> If a new international application is being filed and the international application includes the necessary components for an international filing date (see PCT Article 11 and MPEP 1810), a Notification of the International Application Number and of the International Filing Date (Form PCT/RO/105) will be issued in due course, subject to prescriptions concerning national security, and the date shown on this Acknowledgement Receipt will establish the international filing date of the application.</p>					

Under the Paperwork Reduction Act of 1995, no persons are required to respond to a collection of information unless it displays a valid OMB control number.

<h2>TRANSMITTAL FORM</h2> <p><i>(to be used for all correspondence after initial filing)</i></p>	Application Number	14/054,004
	Filing Date	October 15, 2013
	First Named Inventor	Niall R. Lynam
	Art Unit	2872
	Examiner Name	
Total Number of Pages in This Submission	Attorney Docket Number	DON09 P-2194

ENCLOSURES (Check all that apply)		
<input type="checkbox"/> Fee Transmittal Form	<input type="checkbox"/> Drawing(s)	<input type="checkbox"/> After Allowance Communication to TC
<input type="checkbox"/> Fee Attached	<input type="checkbox"/> Licensing-related Papers	<input type="checkbox"/> Appeal Communication to Board of Appeals and Interferences
<input checked="" type="checkbox"/> Amendment/Reply	<input type="checkbox"/> Petition	<input type="checkbox"/> Appeal Communication to TC (Appeal Notice, Brief, Reply Brief)
<input type="checkbox"/> After Final	<input type="checkbox"/> Petition to Convert to a Provisional Application	<input type="checkbox"/> Proprietary Information
<input checked="" type="checkbox"/> Affidavits/declaration(s)	<input type="checkbox"/> Power of Attorney, Revocation	<input type="checkbox"/> Status Letter
<input type="checkbox"/> Extension of Time Request	<input type="checkbox"/> Change of Correspondence Address	<input type="checkbox"/> Other Enclosure(s) (please Identify below):
<input type="checkbox"/> Express Abandonment Request	<input type="checkbox"/> Terminal Disclaimer	
<input type="checkbox"/> Information Disclosure Statement	<input type="checkbox"/> Request for Refund	
<input type="checkbox"/> Certified Copy of Priority Document(s)	<input type="checkbox"/> CD, Number of CD(s) _____	
<input type="checkbox"/> Reply to Missing Parts/ Incomplete Application	<input type="checkbox"/> Landscape Table on CD	
<input type="checkbox"/> Reply to Missing Parts under 37 CFR 1.52 or 1.53	Remarks	

SIGNATURE OF APPLICANT, ATTORNEY, OR AGENT			
Firm Name	GARDNER, LINN, BURKHART & FLORY, LLP		
Signature	/taf/		
Printed name	Timothy A. Flory		
Date	March 17, 2014	Reg. No.	42540

CERTIFICATE OF TRANSMISSION/MAILING			
I hereby certify that this correspondence is being facsimile transmitted to the USPTO or deposited with the United States Postal Service with sufficient postage as first class mail in an envelope addressed to: Commissioner for Patents, P.O. Box 1450, Alexandria, VA 22313-1450 on the date shown below:			
Signature	/ars/		
Typed or printed name	Amanda R. Sytsma	Date	March 17, 2014

This collection of information is required by 37 CFR 1.5. The information is required to obtain or retain a benefit by the public which is to file (and by the USPTO to process) an application. Confidentiality is governed by 35 U.S.C. 122 and 37 CFR 1.11 and 1.14. This collection is estimated to 2 hours to complete, including gathering, preparing, and submitting the completed application form to the USPTO. Time will vary depending upon the individual case. Any comments on the amount of time you require to complete this form and/or suggestions for reducing this burden, should be sent to the Chief Information Officer, U.S. Patent and Trademark Office, U.S. Department of Commerce, P.O. Box 1450, Alexandria, VA 22313-1450. DO NOT SEND FEES OR COMPLETED FORMS TO THIS ADDRESS. SEND TO: **Commissioner for Patents, P.O. Box 1450, Alexandria, VA 22313-1450.**

If you need assistance in completing the form, call 1-800-PTO-9199 and select option 2.

Under the Paperwork Reduction Act of 1995, no persons are required to respond to a collection of information unless it displays a valid OMB control number.

PATENT APPLICATION FEE DETERMINATION RECORD Substitute for Form PTO-875			Application or Docket Number 14/054,004	Filing Date 10/15/2013	<input type="checkbox"/> To be Mailed
ENTITY: <input checked="" type="checkbox"/> LARGE <input type="checkbox"/> SMALL <input type="checkbox"/> MICRO					
APPLICATION AS FILED – PART I					
(Column 1)			(Column 2)		
FOR	NUMBER FILED	NUMBER EXTRA	RATE (\$)	FEE (\$)	
<input type="checkbox"/> BASIC FEE <small>(37 CFR 1.16(a), (b), or (c))</small>	N/A	N/A	N/A		
<input type="checkbox"/> SEARCH FEE <small>(37 CFR 1.16(k), (i), or (m))</small>	N/A	N/A	N/A		
<input type="checkbox"/> EXAMINATION FEE <small>(37 CFR 1.16(o), (p), or (q))</small>	N/A	N/A	N/A		
TOTAL CLAIMS <small>(37 CFR 1.16(i))</small>	minus 20 =	*	X \$ =		
INDEPENDENT CLAIMS <small>(37 CFR 1.16(h))</small>	minus 3 =	*	X \$ =		
<input type="checkbox"/> APPLICATION SIZE FEE <small>(37 CFR 1.16(s))</small>	If the specification and drawings exceed 100 sheets of paper, the application size fee due is \$310 (\$155 for small entity) for each additional 50 sheets or fraction thereof. See 35 U.S.C. 41(a)(1)(G) and 37 CFR 1.16(s).				
<input type="checkbox"/> MULTIPLE DEPENDENT CLAIM PRESENT <small>(37 CFR 1.16(j))</small>					
* If the difference in column 1 is less than zero, enter "0" in column 2.			TOTAL		

APPLICATION AS AMENDED – PART II								
(Column 1)		(Column 2)		(Column 3)				
AMENDMENT	03/17/2014	CLAIMS REMAINING AFTER AMENDMENT		HIGHEST NUMBER PREVIOUSLY PAID FOR	PRESENT EXTRA	RATE (\$)	ADDITIONAL FEE (\$)	
	<small>Total (37 CFR 1.16(i))</small>	* 20	Minus	** 20	= 0	X \$80 =	0	
	<small>Independent (37 CFR 1.16(h))</small>	* 3	Minus	***3	= 0	X \$420 =	0	
	<input type="checkbox"/> Application Size Fee (37 CFR 1.16(s))							
	<input type="checkbox"/> FIRST PRESENTATION OF MULTIPLE DEPENDENT CLAIM (37 CFR 1.16(j))							
TOTAL ADD'L FEE						0		

(Column 1)		(Column 2)		(Column 3)				
AMENDMENT		CLAIMS REMAINING AFTER AMENDMENT		HIGHEST NUMBER PREVIOUSLY PAID FOR	PRESENT EXTRA	RATE (\$)	ADDITIONAL FEE (\$)	
	<small>Total (37 CFR 1.16(i))</small>	*	Minus	**	=	X \$ =		
	<small>Independent (37 CFR 1.16(h))</small>	*	Minus	***	=	X \$ =		
	<input type="checkbox"/> Application Size Fee (37 CFR 1.16(s))							
	<input type="checkbox"/> FIRST PRESENTATION OF MULTIPLE DEPENDENT CLAIM (37 CFR 1.16(j))							
TOTAL ADD'L FEE								
* If the entry in column 1 is less than the entry in column 2, write "0" in column 3. ** If the "Highest Number Previously Paid For" IN THIS SPACE is less than 20, enter "20". *** If the "Highest Number Previously Paid For" IN THIS SPACE is less than 3, enter "3". The "Highest Number Previously Paid For" (Total or Independent) is the highest number found in the appropriate box in column 1.						LIE /MOLIKI MAY/		

This collection of information is required by 37 CFR 1.16. The information is required to obtain or retain a benefit by the public which is to file (and by the USPTO to process) an application. Confidentiality is governed by 35 U.S.C. 122 and 37 CFR 1.14. This collection is estimated to take 12 minutes to complete, including gathering, preparing, and submitting the completed application form to the USPTO. Time will vary depending upon the individual case. Any comments on the amount of time you require to complete this form and/or suggestions for reducing this burden, should be sent to the Chief Information Officer, U.S. Patent and Trademark Office, U.S. Department of Commerce, P.O. Box 1450, Alexandria, VA 22313-1450. DO NOT SEND FEES OR COMPLETED FORMS TO THIS ADDRESS. **SEND TO: Commissioner for Patents, P.O. Box 1450, Alexandria, VA 22313-1450.**
 If you need assistance in completing the form, call 1-800-PTO-9199 and select option 2.



UNITED STATES PATENT AND TRADEMARK OFFICE

UNITED STATES DEPARTMENT OF COMMERCE
United States Patent and Trademark Office
Address: COMMISSIONER FOR PATENTS
P.O. Box 1450
Alexandria, Virginia 22313-1450
www.uspto.gov

NOTICE OF ALLOWANCE AND FEE(S) DUE

15671 7590 06/10/2014
Gardner, Linn, Burkhardt & Flory, LLP
2851 Charlevoix Dr., SE, Suite 207
Grand Rapids, MI 49546

EXAMINER

KAKALEC, KIMBERLY N

ART UNIT PAPER NUMBER

2872

DATE MAILED: 06/10/2014

Table with 5 columns: APPLICATION NO., FILING DATE, FIRST NAMED INVENTOR, ATTORNEY DOCKET NO., CONFIRMATION NO.
14/054,004 10/15/2013 Niall R. Lynam DON09 P-2194 4390

TITLE OF INVENTION: EXTENDED FIELD OF VIEW EXTERIOR MIRROR ELEMENT FOR VEHICLE

Table with 7 columns: APPLN. TYPE, ENTITY STATUS, ISSUE FEE DUE, PUBLICATION FEE DUE, PREV. PAID ISSUE FEE, TOTAL FEE(S) DUE, DATE DUE
nonprovisional UNDISCOUNTED \$960 \$0 \$0 \$960 09/10/2014

THE APPLICATION IDENTIFIED ABOVE HAS BEEN EXAMINED AND IS ALLOWED FOR ISSUANCE AS A PATENT. PROSECUTION ON THE MERITS IS CLOSED. THIS NOTICE OF ALLOWANCE IS NOT A GRANT OF PATENT RIGHTS. THIS APPLICATION IS SUBJECT TO WITHDRAWAL FROM ISSUE AT THE INITIATIVE OF THE OFFICE OR UPON PETITION BY THE APPLICANT. SEE 37 CFR 1.313 AND MPEP 1308.

THE ISSUE FEE AND PUBLICATION FEE (IF REQUIRED) MUST BE PAID WITHIN THREE MONTHS FROM THE MAILING DATE OF THIS NOTICE OR THIS APPLICATION SHALL BE REGARDED AS ABANDONED. THIS STATUTORY PERIOD CANNOT BE EXTENDED. SEE 35 U.S.C. 151. THE ISSUE FEE DUE INDICATED ABOVE DOES NOT REFLECT A CREDIT FOR ANY PREVIOUSLY PAID ISSUE FEE IN THIS APPLICATION. IF AN ISSUE FEE HAS PREVIOUSLY BEEN PAID IN THIS APPLICATION (AS SHOWN ABOVE), THE RETURN OF PART B OF THIS FORM WILL BE CONSIDERED A REQUEST TO REAPPLY THE PREVIOUSLY PAID ISSUE FEE TOWARD THE ISSUE FEE NOW DUE.

HOW TO REPLY TO THIS NOTICE:

I. Review the ENTITY STATUS shown above. If the ENTITY STATUS is shown as SMALL or MICRO, verify whether entitlement to that entity status still applies.

If the ENTITY STATUS is the same as shown above, pay the TOTAL FEE(S) DUE shown above.

If the ENTITY STATUS is changed from that shown above, on PART B - FEE(S) TRANSMITTAL, complete section number 5 titled "Change in Entity Status (from status indicated above)".

For purposes of this notice, small entity fees are 1/2 the amount of undiscounted fees, and micro entity fees are 1/2 the amount of small entity fees.

II. PART B - FEE(S) TRANSMITTAL, or its equivalent, must be completed and returned to the United States Patent and Trademark Office (USPTO) with your ISSUE FEE and PUBLICATION FEE (if required). If you are charging the fee(s) to your deposit account, section "4b" of Part B - Fee(s) Transmittal should be completed and an extra copy of the form should be submitted. If an equivalent of Part B is filed, a request to reapply a previously paid issue fee must be clearly made, and delays in processing may occur due to the difficulty in recognizing the paper as an equivalent of Part B.

III. All communications regarding this application must give the application number. Please direct all communications prior to issuance to Mail Stop ISSUE FEE unless advised to the contrary.

IMPORTANT REMINDER: Utility patents issuing on applications filed on or after Dec. 12, 1980 may require payment of maintenance fees. It is patentee's responsibility to ensure timely payment of maintenance fees when due.

PART B - FEE(S) TRANSMITTAL

**Complete and send this form, together with applicable fee(s), to: Mail Mail Stop ISSUE FEE
 Commissioner for Patents
 P.O. Box 1450
 Alexandria, Virginia 22313-1450
 or Fax (571)-273-2885**

INSTRUCTIONS: This form should be used for transmitting the ISSUE FEE and PUBLICATION FEE (if required). Blocks 1 through 5 should be completed where appropriate. All further correspondence including the Patent, advance orders and notification of maintenance fees will be mailed to the current correspondence address as indicated unless corrected below or directed otherwise in Block 1, by (a) specifying a new correspondence address; and/or (b) indicating a separate "FEE ADDRESS" for maintenance fee notifications.

CURRENT CORRESPONDENCE ADDRESS (Note: Use Block 1 for any change of address)

15671 7590 06/10/2014
 Gardner, Linn, Burkhardt & Flory, LLP
 2851 Charlevoix Dr., SE, Suite 207
 Grand Rapids, MI 49546

Note: A certificate of mailing can only be used for domestic mailings of the Fee(s) Transmittal. This certificate cannot be used for any other accompanying papers. Each additional paper, such as an assignment or formal drawing, must have its own certificate of mailing or transmission.

Certificate of Mailing or Transmission

I hereby certify that this Fee(s) Transmittal is being deposited with the United States Postal Service with sufficient postage for first class mail in an envelope addressed to the Mail Stop ISSUE FEE address above, or being facsimile transmitted to the USPTO (571) 273-2885, on the date indicated below.

_____ (Depositor's name)
_____ (Signature)
_____ (Date)

APPLICATION NO.	FILING DATE	FIRST NAMED INVENTOR	ATTORNEY DOCKET NO.	CONFIRMATION NO.
14/054,004	10/15/2013	Niall R. Lynam	DON09 P-2194	4390

TITLE OF INVENTION: EXTENDED FIELD OF VIEW EXTERIOR MIRROR ELEMENT FOR VEHICLE

APPLN. TYPE	ENTITY STATUS	ISSUE FEE DUE	PUBLICATION FEE DUE	PREV. PAID ISSUE FEE	TOTAL FEE(S) DUE	DATE DUE
nonprovisional	UNDISCOUNTED	\$960	\$0	\$0	\$960	09/10/2014

EXAMINER	ART UNIT	CLASS-SUBCLASS
KAKALEC, KIMBERLY N	2872	359-866000

<p>1. Change of correspondence address or indication of "Fee Address" (37 CFR 1.363).</p> <p><input type="checkbox"/> Change of correspondence address (or Change of Correspondence Address form PTO/SB/122) attached.</p> <p><input type="checkbox"/> "Fee Address" indication (or "Fee Address" Indication form PTO/SB/47; Rev 03-02 or more recent) attached. Use of a Customer Number is required.</p>	<p>2. For printing on the patent front page, list</p> <p>(1) The names of up to 3 registered patent attorneys or agents OR, alternatively, _____ 1</p> <p>(2) The name of a single firm (having as a member a registered attorney or agent) and the names of up to 2 registered patent attorneys or agents. If no name is listed, no name will be printed. _____ 2</p> <p>_____ 3</p>
---	---

3. ASSIGNEE NAME AND RESIDENCE DATA TO BE PRINTED ON THE PATENT (print or type)

PLEASE NOTE: Unless an assignee is identified below, no assignee data will appear on the patent. If an assignee is identified below, the document has been filed for recordation as set forth in 37 CFR 3.11. Completion of this form is NOT a substitute for filing an assignment.

(A) NAME OF ASSIGNEE _____ (B) RESIDENCE: (CITY and STATE OR COUNTRY) _____

Please check the appropriate assignee category or categories (will not be printed on the patent): Individual Corporation or other private group entity Government

<p>4a. The following fee(s) are submitted:</p> <p><input type="checkbox"/> Issue Fee</p> <p><input type="checkbox"/> Publication Fee (No small entity discount permitted)</p> <p><input type="checkbox"/> Advance Order - # of Copies _____</p>	<p>4b. Payment of Fee(s): (Please first reapply any previously paid issue fee shown above)</p> <p><input type="checkbox"/> A check is enclosed.</p> <p><input type="checkbox"/> Payment by credit card. Form PTO-2038 is attached.</p> <p><input type="checkbox"/> The Director is hereby authorized to charge the required fee(s), any deficiency, or credits any overpayment, to Deposit Account Number _____ (enclose an extra copy of this form).</p>
---	--

5. **Change in Entity Status** (from status indicated above)

Applicant certifying micro entity status. See 37 CFR 1.29

Applicant asserting small entity status. See 37 CFR 1.27

Applicant changing to regular undiscounted fee status.

NOTE: Absent a valid certification of Micro Entity Status (see forms PTO/SB/15A and 15B), issue fee payment in the micro entity amount will not be accepted at the risk of application abandonment.

NOTE: If the application was previously under micro entity status, checking this box will be taken to be a notification of loss of entitlement to micro entity status.

NOTE: Checking this box will be taken to be a notification of loss of entitlement to small or micro entity status, as applicable.

NOTE: This form must be signed in accordance with 37 CFR 1.31 and 1.33. See 37 CFR 1.4 for signature requirements and certifications.

Authorized Signature _____	Date _____
Typed or printed name _____	Registration No. _____



UNITED STATES PATENT AND TRADEMARK OFFICE

UNITED STATES DEPARTMENT OF COMMERCE
United States Patent and Trademark Office
Address: COMMISSIONER FOR PATENTS
P.O. Box 1450
Alexandria, Virginia 22313-1450
www.uspto.gov

Table with 5 columns: APPLICATION NO., FILING DATE, FIRST NAMED INVENTOR, ATTORNEY DOCKET NO., CONFIRMATION NO.

15671 7590 06/10/2014
Gardner, Linn, Burkhardt & Flory, LLP
2851 Charlevoix Dr., SE, Suite 207
Grand Rapids, MI 49546

EXAMINER

KAKALEC, KIMBERLY N

ART UNIT PAPER NUMBER

2872

DATE MAILED: 06/10/2014

Determination of Patent Term Adjustment under 35 U.S.C. 154 (b)
(Applications filed on or after May 29, 2000)

The Office has discontinued providing a Patent Term Adjustment (PTA) calculation with the Notice of Allowance.

Section 1(h)(2) of the AIA Technical Corrections Act amended 35 U.S.C. 154(b)(3)(B)(i) to eliminate the requirement that the Office provide a patent term adjustment determination with the notice of allowance. See Revisions to Patent Term Adjustment, 78 Fed. Reg. 19416, 19417 (Apr. 1, 2013). Therefore, the Office is no longer providing an initial patent term adjustment determination with the notice of allowance. The Office will continue to provide a patent term adjustment determination with the Issue Notification Letter that is mailed to applicant approximately three weeks prior to the issue date of the patent, and will include the patent term adjustment on the patent. Any request for reconsideration of the patent term adjustment determination (or reinstatement of patent term adjustment) should follow the process outlined in 37 CFR 1.705.

Any questions regarding the Patent Term Extension or Adjustment determination should be directed to the Office of Patent Legal Administration at (571)-272-7702. Questions relating to issue and publication fee payments should be directed to the Customer Service Center of the Office of Patent Publication at 1-(888)-786-0101 or (571)-272-4200.

OMB Clearance and PRA Burden Statement for PTOL-85 Part B

The Paperwork Reduction Act (PRA) of 1995 requires Federal agencies to obtain Office of Management and Budget approval before requesting most types of information from the public. When OMB approves an agency request to collect information from the public, OMB (i) provides a valid OMB Control Number and expiration date for the agency to display on the instrument that will be used to collect the information and (ii) requires the agency to inform the public about the OMB Control Number's legal significance in accordance with 5 CFR 1320.5(b).

The information collected by PTOL-85 Part B is required by 37 CFR 1.311. The information is required to obtain or retain a benefit by the public which is to file (and by the USPTO to process) an application. Confidentiality is governed by 35 U.S.C. 122 and 37 CFR 1.14. This collection is estimated to take 12 minutes to complete, including gathering, preparing, and submitting the completed application form to the USPTO. Time will vary depending upon the individual case. Any comments on the amount of time you require to complete this form and/or suggestions for reducing this burden, should be sent to the Chief Information Officer, U.S. Patent and Trademark Office, U.S. Department of Commerce, P.O. Box 1450, Alexandria, Virginia 22313-1450. DO NOT SEND FEES OR COMPLETED FORMS TO THIS ADDRESS. SEND TO: Commissioner for Patents, P.O. Box 1450, Alexandria, Virginia 22313-1450. Under the Paperwork Reduction Act of 1995, no persons are required to respond to a collection of information unless it displays a valid OMB control number.

Privacy Act Statement

The Privacy Act of 1974 (P.L. 93-579) requires that you be given certain information in connection with your submission of the attached form related to a patent application or patent. Accordingly, pursuant to the requirements of the Act, please be advised that: (1) the general authority for the collection of this information is 35 U.S.C. 2(b)(2); (2) furnishing of the information solicited is voluntary; and (3) the principal purpose for which the information is used by the U.S. Patent and Trademark Office is to process and/or examine your submission related to a patent application or patent. If you do not furnish the requested information, the U.S. Patent and Trademark Office may not be able to process and/or examine your submission, which may result in termination of proceedings or abandonment of the application or expiration of the patent.

The information provided by you in this form will be subject to the following routine uses:

1. The information on this form will be treated confidentially to the extent allowed under the Freedom of Information Act (5 U.S.C. 552) and the Privacy Act (5 U.S.C. 552a). Records from this system of records may be disclosed to the Department of Justice to determine whether disclosure of these records is required by the Freedom of Information Act.
2. A record from this system of records may be disclosed, as a routine use, in the course of presenting evidence to a court, magistrate, or administrative tribunal, including disclosures to opposing counsel in the course of settlement negotiations.
3. A record in this system of records may be disclosed, as a routine use, to a Member of Congress submitting a request involving an individual, to whom the record pertains, when the individual has requested assistance from the Member with respect to the subject matter of the record.
4. A record in this system of records may be disclosed, as a routine use, to a contractor of the Agency having need for the information in order to perform a contract. Recipients of information shall be required to comply with the requirements of the Privacy Act of 1974, as amended, pursuant to 5 U.S.C. 552a(m).
5. A record related to an International Application filed under the Patent Cooperation Treaty in this system of records may be disclosed, as a routine use, to the International Bureau of the World Intellectual Property Organization, pursuant to the Patent Cooperation Treaty.
6. A record in this system of records may be disclosed, as a routine use, to another federal agency for purposes of National Security review (35 U.S.C. 181) and for review pursuant to the Atomic Energy Act (42 U.S.C. 218(c)).
7. A record from this system of records may be disclosed, as a routine use, to the Administrator, General Services, or his/her designee, during an inspection of records conducted by GSA as part of that agency's responsibility to recommend improvements in records management practices and programs, under authority of 44 U.S.C. 2904 and 2906. Such disclosure shall be made in accordance with the GSA regulations governing inspection of records for this purpose, and any other relevant (i.e., GSA or Commerce) directive. Such disclosure shall not be used to make determinations about individuals.
8. A record from this system of records may be disclosed, as a routine use, to the public after either publication of the application pursuant to 35 U.S.C. 122(b) or issuance of a patent pursuant to 35 U.S.C. 151. Further, a record may be disclosed, subject to the limitations of 37 CFR 1.14, as a routine use, to the public if the record was filed in an application which became abandoned or in which the proceedings were terminated and which application is referenced by either a published application, an application open to public inspection or an issued patent.
9. A record from this system of records may be disclosed, as a routine use, to a Federal, State, or local law enforcement agency, if the USPTO becomes aware of a violation or potential violation of law or regulation.

Notice of Allowability	Application No. 14/054,004	Applicant(s) LYNAM, NIAL R.	
	Examiner KIMBERLY N. KAKALEC	Art Unit 2872	AIA (First Inventor to File) Status No

-- The MAILING DATE of this communication appears on the cover sheet with the correspondence address--

All claims being allowable, PROSECUTION ON THE MERITS IS (OR REMAINS) CLOSED in this application. If not included herewith (or previously mailed), a Notice of Allowance (PTOL-85) or other appropriate communication will be mailed in due course. **THIS NOTICE OF ALLOWABILITY IS NOT A GRANT OF PATENT RIGHTS.** This application is subject to withdrawal from issue at the initiative of the Office or upon petition by the applicant. See 37 CFR 1.313 and MPEP 1308.

1. This communication is responsive to response of 3/17/2014.
 A declaration(s)/affidavit(s) under **37 CFR 1.130(b)** was/were filed on _____.
2. An election was made by the applicant in response to a restriction requirement set forth during the interview on _____; the restriction requirement and election have been incorporated into this action.
3. The allowed claim(s) is/are 1-20. As a result of the allowed claim(s), you may be eligible to benefit from the **Patent Prosecution Highway** program at a participating intellectual property office for the corresponding application. For more information, please see http://www.uspto.gov/patents/init_events/pph/index.jsp or send an inquiry to PPHfeedback@uspto.gov.
4. Acknowledgment is made of a claim for foreign priority under 35 U.S.C. § 119(a)-(d) or (f).

Certified copies:

- a) All b) Some *c) None of the:
1. Certified copies of the priority documents have been received.
 2. Certified copies of the priority documents have been received in Application No. _____.
 3. Copies of the certified copies of the priority documents have been received in this national stage application from the International Bureau (PCT Rule 17.2(a)).

* Certified copies not received: _____.

Applicant has THREE MONTHS FROM THE "MAILING DATE" of this communication to file a reply complying with the requirements noted below. Failure to timely comply will result in ABANDONMENT of this application.

THIS THREE-MONTH PERIOD IS NOT EXTENDABLE.

5. CORRECTED DRAWINGS (as "replacement sheets") must be submitted.
 including changes required by the attached Examiner's Amendment / Comment or in the Office action of Paper No./Mail Date _____.
Identifying indicia such as the application number (see 37 CFR 1.84(c)) should be written on the drawings in the front (not the back) of each sheet. Replacement sheet(s) should be labeled as such in the header according to 37 CFR 1.121(d).
6. DEPOSIT OF and/or INFORMATION about the deposit of BIOLOGICAL MATERIAL must be submitted. Note the attached Examiner's comment regarding REQUIREMENT FOR THE DEPOSIT OF BIOLOGICAL MATERIAL.

Attachment(s)

- | | |
|---|---|
| <ol style="list-style-type: none"> 1. <input type="checkbox"/> Notice of References Cited (PTO-892) 2. <input type="checkbox"/> Information Disclosure Statements (PTO/SB/08), Paper No./Mail Date _____ 3. <input type="checkbox"/> Examiner's Comment Regarding Requirement for Deposit of Biological Material 4. <input type="checkbox"/> Interview Summary (PTO-413), Paper No./Mail Date _____ | <ol style="list-style-type: none"> 5. <input type="checkbox"/> Examiner's Amendment/Comment 6. <input checked="" type="checkbox"/> Examiner's Statement of Reasons for Allowance 7. <input type="checkbox"/> Other _____ |
|---|---|

--	--

DETAILED ACTION

Notice of Pre-AIA or AIA Status

The present application is being examined under the pre-AIA first to invent provisions.

Response to Declaration

The declaration filed on March 17, 2014 under 37 CFR 1.131(a) is sufficient to overcome the Lynam et al. reference (US 2002/0072026 A1), and to demonstrate that Applicant is entitled to the benefit of the earlier filing date of prior-filed Application No. 12/197,666 (and its parent Application 10/709,434 and Provisional Application No. 60/471,872).

Allowable Subject Matter

Claims 1-20 are allowed.

Claim 1 is allowable for at least the reason “wherein said main plano mirror element and said auxiliary non-plano curved mirror element are adjacently disposed at said mirror backing plate element in a side-by-side relationship and are not superimposed with one mirror element on top of the other mirror element; said auxiliary non-plano curved mirror element having a second auxiliary field of view rearward of the equipped vehicle; wherein said first primary field of view of said main plano mirror element overlaps said second auxiliary field of view of said auxiliary non-plano curved mirror element; wherein said auxiliary non-plano curved mirror element that is at said second portion of said mirror backing plate element is angled relative to said main plano mirror element that is at said first portion of said mirror backing plate element,” as set forth in the claimed combination.

Claims 2-14 are allowable due to their dependence on Claim 1.

Claim 15 is allowable for at least the reason “wherein said main plano mirror element and said auxiliary non-plano curved mirror element are adjacently disposed at said mirror backing plate element in a side-by-side relationship and are not superimposed with one mirror element on top of the other mirror element; wherein said second portion of said mirror backing plate element has a curvature at least partially matching the curvature of said auxiliary non-plano curved mirror element; said auxiliary non-plano curved mirror element having a second auxiliary field of view rearward of the equipped vehicle; wherein said first primary field of view of said main plano mirror element overlaps said second auxiliary field of view of said auxiliary non-plano curved mirror element; wherein said auxiliary non-plano curved mirror element that is at said second portion of said mirror backing plate element is angled relative to said main plano mirror element that is at said first portion of said mirror backing plate element,” as set forth in the claimed combination.

Claims 16-17 are allowable due to their dependence on Claim 15.

Claim 18 is allowable for at least the reason “wherein said main plano mirror element and said auxiliary non-plano curved mirror element are adjacently disposed at said mirror backing plate element in a side-by-side relationship and are not superimposed with one mirror element on top of the other mirror element; said auxiliary non-plano curved mirror element having a second auxiliary field of view rearward of the equipped vehicle; wherein said first primary field of view of said main plano mirror element overlaps said second auxiliary field of view of said auxiliary non-plano curved mirror element by between about 2 degrees and about 20 degrees; wherein said auxiliary non-plano curved mirror element that is at said second portion of said mirror backing

plate element is angled relative to said main plano mirror element that is at said first portion of said mirror backing plate element," as set forth in the claimed combination.

Claims 19-20 are allowable due to their dependence on Claim 18.

Any comments considered necessary by applicant must be submitted no later than the payment of the issue fee and, to avoid processing delays, should preferably accompany the issue fee. Such submissions should be clearly labeled "Comments on Statement of Reasons for Allowance."

Response to Arguments

Applicant's arguments, see p.3, filed March 17, 2014, with respect to the priority objection and the rejection over Lynam et al. have been fully considered and are persuasive. The priority objection and the rejections of claims 1-20 have been withdrawn.

Conclusion

Any inquiry concerning this communication or earlier communications from the examiner should be directed to KIMBERLY N. KAKALEC whose telephone number is (571)270-5802. The examiner can normally be reached on Monday through Thursday, 8:30 am to 6:00 pm EST, Alt. Fridays 8:30 am to 5:00 pm EST.

If attempts to reach the examiner by telephone are unsuccessful, the examiner's supervisor, Stephone B. Allen can be reached on (571)272-2434. The fax phone number for the organization where this application or proceeding is assigned is 571-273-8300.

Information regarding the status of an application may be obtained from the Patent Application Information Retrieval (PAIR) system. Status information for published applications may be obtained from either Private PAIR or Public PAIR. Status information for unpublished applications is available through Private PAIR only. For more information about the PAIR system, see <http://pair-direct.uspto.gov>. Should you have questions on access to the Private PAIR system, contact the Electronic Business Center (EBC) at 866-217-9197 (toll-free). If you would like assistance from a USPTO Customer Service Representative or access to the automated information system, call 800-786-9199 (IN USA OR CANADA) or 571-272-1000.

/K. N. K./
Examiner, Art Unit 2872

/STEPHONE B. ALLEN/
Supervisory Patent Examiner, Art Unit 2872

Search Notes 	Application/Control No. 14054004	Applicant(s)/Patent Under Reexamination LYNAM, NIALL R.
	Examiner KIMBERLY N KAKALEC	Art Unit 2872

CPC- SEARCHED		
Symbol	Date	Examiner
B60R1/\$	5/14	KNK
G92B5/08\$	5/14	KNK

CPC COMBINATION SETS - SEARCHED		
Symbol	Date	Examiner

US CLASSIFICATION SEARCHED			
Class	Subclass	Date	Examiner
359	838, 850, 864, 868-869, 871-878, 881-884	12/13	KNK
248	466-498	12/13	KNK
	modified by text: (plano or planar) and (curv\$ or non?plano or non?planar)		

SEARCH NOTES		
Search Notes	Date	Examiner
Inventor name search.	12/13	KNK
Reviewed references cited in IDS.	12/13	KNK
EAST search (see attached search history).	12/13	KNK
Consulted with Jennifer Doak.	12/13	KNK
Updated EAST search (see attached search history).	5/14	KNK
Consulted with Jennifer Doak.	5/14	KNK

INTERFERENCE SEARCH			
US Class/ CPC Symbol	US Subclass / CPC Group	Date	Examiner
	PG-Pub/USPAT/UPAD text search.	5/14	KNK

/K.N.K./ Examiner.Art Unit 2872	
------------------------------------	--

Issue Classification 	Application/Control No. 14054004	Applicant(s)/Patent Under Reexamination LYNAM, NIALL R.
	Examiner KIMBERLY N KAKALEC	Art Unit 2872

<input checked="" type="checkbox"/> Claims renumbered in the same order as presented by applicant <input type="checkbox"/> CPA <input type="checkbox"/> T.D. <input type="checkbox"/> R.1.47															
Final	Original	Final	Original	Final	Original	Final	Original	Final	Original	Final	Original	Final	Original	Final	Original
1	1	17	17												
2	2	18	18												
3	3	19	19												
4	4	20	20												
5	5														
6	6														
7	7														
8	8														
9	9														
10	10														
11	11														
12	12														
13	13														
14	14														
15	15														
16	16														

/KIMBERLY N KAKALEC/ Examiner.Art Unit 2872 (Assistant Examiner)	5/14/2014 (Date)	Total Claims Allowed: 20	
/STEPHONE B ALLEN/ Supervisory Patent Examiner.Art Unit 2872 (Primary Examiner)	05/28/2014 (Date)	O.G. Print Claim(s) 1	O.G. Print Figure 11

EAST Search History

EAST Search History (Prior Art)

Ref #	Hits	Search Query	DBs	Default Operator	Plurals	Time Stamp
S1	2	10/709,434.app.	US-PGPUB; USPAT	ADJ	ON	2013/12/05 10:28
S2	218	"10/709,434"	US-PGPUB; USPAT	ADJ	ON	2013/12/05 10:28
S3	97	"10/709,434"	USPAT	ADJ	ON	2013/12/05 10:30
S4	2	(plano mirror and auxiliary non?plano curved mirror).clm.	USPAT	ADJ	ON	2013/12/05 10:30
S5	713	((NIALL) near2 (LYNAM)).INV.	US-PGPUB; USPAT	ADJ	ON	2013/12/05 10:35
S6	282	S5 and (plano or planar) and (curv\$ or non?plano or non?planar)	US-PGPUB; USPAT	ADJ	ON	2013/12/05 10:40
S7	6322	359/838,850,864,868-869,871-878,881-884.ccls.	US-PGPUB; USPAT	ADJ	ON	2013/12/05 10:42
S8	2951	S7 and (vehicle or automobile or car or truck or van)	US-PGPUB; USPAT	ADJ	ON	2013/12/05 10:42
S9	435	S8 and (plano or planar) and (curv\$ or non?plano or non?planar)	US-PGPUB; USPAT	ADJ	ON	2013/12/05 10:43
S10	248	"1114559" "1672559" "2135262" "2263382" "2279751" "2514989" "2580014" "2636419" "2778273" "2890539" "2911177" "20020036828" "20020048100" "20020072026" "20020105741" "20020159169" "20020159270" "20030026009" "20030026012" "20030031023" "20030043589" "20030117731" "20040032638" "20040032675" "20040032676" "20040114260" "20040165291" "20040257685" "20040264011" "20050078389" "20050083577" "20050099693" "20050134983" "20050232469" "20050248859" "20060050018" "20060061008" "20060125919" "20060126150" "20060171704" "20060184297" "20060268440" "20060279863" "20070058257" "20070285789" "20080212189" "20080225421" "20080304170" "20080308219" "20090040306" "20090115631" "20090237820" "20090268321" "20100195228"	US-PGPUB; USPAT	ADJ	ON	2013/12/05 10:53

"20100296187"	"20110157732"	
"20110170207"	"20120314316"	
"20130188237"	"20130188269"	
"3104274"	"3131250"	"3146296"
"3170985"	"3175463"	"3266016"
"3267806"	"3280701"	"3337285"
"3338655"	"3375053"	"3389952"
"3404935"	"3408136"	"3424517"
"3563638"	"3601614"	"3610739"
"3667833"	"3708222"	"3759647"
"3764201"	"3773882"	"3806232"
"3826563"	"3881811"	"3884606"
"3909117"	"4193668"	"4200359"
"4223983"	"4258979"	"4264144"
"4268120"	"4281899"	"4293191"
"4303308"	"4306770"	"4311362"
"4311363"	"4325609"	"4331382"
"4350412"	"4385804"	"4435042"
"4436371"	"4436372"	"4439013"
"4449786"	"4470665"	"4499451"
"4526446"	"4549786"	"4555166"
"4575202"	"4588267"	"4609266"
"4623222"	"4629296"	"4630904"
"4666264"	"4674849"	"4674850"
"4678294"	"4679906"	"4712879"
"4715701"	"4721364"	"4727302"
"4733336"	"4737188"	"4770522"
"4773740"	"4793690"	"4799768"
"4824231"	"4826289"	"4828379"
"4853283"	"4859046"	"4882466"
"4882565"	"4906075"	"4906085"
"4913542"	"4917485"	"4929074"
"4932769"	"4932770"	"4944581"
"4948242"	"4989964"	"5005962"
"5014167"	"5022747"	"5033835"
"5044739"	"5050977"	"5052792"
"5066112"	"5073012"	"5076673"
"5078480"	"5080492"	"5085907"
"5107374"	"5115346"	"5115352"
"5117346"	"5118540"	"5140455"
"5142407"	"5151816"	"5151824"
"5166833"	"5178448"	"5179471"
"5183099"	"5189537"	"5193029"
"5207492"	"5225943"	"5233461"
"5237458"	"5237459"	"5239405"
"5247395"	"5253109"	"5262894"
"5285060"	"5295021"	"5296973"
"5313335"	"5327288"	"5354965"
"5355245"	"5361172"	"5371659"
"5406414"	"5412512"	"5424875"
"5432643"	"5437931"	"5446576"
"5481409"	"5483386"	"5497305"
"5497306"	"5509606"	"5517367"
"5523877"	"5525264"	"5526195"
"5530588"	"5535056"	"5550677"
"5557467"	"5559640"	"5563744"
"5567360"	"5575552"	"5579133"
"5587236"	"5587699"	"5594222"
"5594593"	"5610756"	"5621569"
"5621577"	"5644442"	"5649756"
"5668663"	"5669698"	"5669699"
"5669704"	"5669705"	"5670935"
"5689370"	"5691855"	"5715093"
"5722836"	"5724187"	"5751489"

		"5760962" "5784211" "5786772" "5788357" "5790298"). PN.				
S11	137	("5790327" "5793542" "5796094" "5796532" "5805367" "5808777" "5823654" "5825527" "5835294" "5838505" "5847889" "5863116" "5864434" "5877897" "5910854" "5922176" "5929786" "5938320" "5980050" "6001486" "6002511" "6005724" "6007207" "6030084" "6032323" "6033078" "6065840" "6074068" "6097023" "6109586" "6111684" "6116743" "6124647" "6128860" "6154306" "6164564" "6172613" "6176602" "6178034" "6196688" "6198409" "6199993" "6201642" "6207083" "6227689" "6245262" "6250148" "6257746" "6260608" "6270225" "6276821" "6286965" "6294989" "6310611" "6315419" "6318870" "6320282" "6329925" "6341523" "6343402" "6356376" "6390632" "6396397" "6398377" "6409354" "6420036" "6428172" "6441964" "6445287" "6449082" "6472979" "6498620" "6501387" "6511192" "6512624" "6522451" "6537138" "6582109" "6595649" "6615438" "6627918" "6642851" "6648477" "6669109" "6690268" "6709119" "6717610" "6717712" "6719215" "6731205" "6737629" "6742904" "6757109" "6824281" "6831268" "6882287" "6919796" "6932483" "6979090" "7001032" "7005974" "7025469" "7038577" "7097312" "7106392" "7126456" "7167294" "7168830" "7184190" "7195381" "7249860" "7255451" "7267448" "7274501" "7289037" "7338177" "7339149" "7345680" "7370983" "7377675" "7391563" "7400435" "7420756" "7423522" "7492281" "7526103" "7581859" "7626749" "7636188" "7857469" "7934843" "8267534" "8562157" "D297926" "D493131" "D493394" "RE17274"). pn.	US- PGPUB; USPAT	ADJ	ON	2013/12/05 10:54
S12	385	S10 or S11	US- PGPUB; USPAT	ADJ	ON	2013/12/05 10:54
S13	248	("1114559" "1672559" "2135262" "2263382" "2279751" "2514989" "2580014" "2636419" "2778273" "2890539" "2911177" "20020036828" "20020048100" "20020072026" "20020105741" "20020159169" "20020159270" "20030026009" "20030026012" "20030031023" "20030043589" "20030117731" "20040032638" "20040032675" "20040032676" "20040114260" "20040165291" "20040257685"	US- PGPUB; USPAT	ADJ	ON	2013/12/05 14:53

"20040264011"	"20050078389"	
"20050083577"	"20050099693"	
"20050134983"	"20050232469"	
"20050248859"	"20060050018"	
"20060061008"	"20060125919"	
"20060126150"	"20060171704"	
"20060184297"	"20060268440"	
"20060279863"	"20070058257"	
"20070285789"	"20080212189"	
"20080225421"	"20080304170"	
"20080308219"	"20090040306"	
"20090115631"	"20090237820"	
"20090268321"	"20100195228"	
"20100296187"	"20110157732"	
"20110170207"	"20120314316"	
"20130188237"	"20130188269"	
"3104274"	"3131250"	"3146296"
"3170985"	"3175463"	"3266016"
"3267806"	"3280701"	"3337285"
"3338655"	"3375053"	"3389952"
"3404935"	"3408136"	"3424517"
"3563638"	"3601614"	"3610739"
"3667833"	"3708222"	"3759647"
"3764201"	"3773882"	"3806232"
"3826563"	"3881811"	"3884606"
"3909117"	"4193668"	"4200359"
"4223983"	"4258979"	"4264144"
"4268120"	"4281899"	"4293191"
"4303308"	"4306770"	"4311362"
"4311363"	"4325609"	"4331382"
"4350412"	"4385804"	"4435042"
"4436371"	"4436372"	"4439013"
"4449786"	"4470665"	"4499451"
"4526446"	"4549786"	"4555166"
"4575202"	"4588267"	"4609266"
"4623222"	"4629296"	"4630904"
"4666264"	"4674849"	"4674850"
"4678294"	"4679906"	"4712879"
"4715701"	"4721364"	"4727302"
"4733336"	"4737188"	"4770522"
"4773740"	"4793690"	"4799768"
"4824231"	"4826289"	"4828379"
"4853283"	"4859046"	"4882466"
"4882565"	"4906075"	"4906085"
"4913542"	"4917485"	"4929074"
"4932769"	"4932770"	"4944581"
"4948242"	"4989964"	"5005962"
"5014167"	"5022747"	"5033835"
"5044739"	"5050977"	"5052792"
"5066112"	"5073012"	"5076673"
"5078480"	"5080492"	"5085907"
"5107374"	"5115346"	"5115352"
"5117346"	"5118540"	"5140455"
"5142407"	"5151816"	"5151824"
"5166833"	"5178448"	"5179471"
"5183099"	"5189537"	"5193029"
"5207492"	"5225943"	"5233461"
"5237458"	"5237459"	"5239405"
"5247395"	"5253109"	"5262894"
"5285060"	"5295021"	"5296973"
"5313335"	"5327288"	"5354965"
"5355245"	"5361172"	"5371659"
"5406414"	"5412512"	"5424875"
"5432643"	"5437931"	"5446576"

EAST Search History

		"5481409" "5483386" "5497305" "5497306" "5509606" "5517367" "5523877" "5525264" "5526195" "5530588" "5535056" "5550677" "5557467" "5559640" "5563744" "5567360" "5575552" "5579133" "5587236" "5587699" "5594222" "5594593" "5610756" "5621569" "5621577" "5644442" "5649756" "5668663" "5669698" "5669699" "5669704" "5669705" "5670935" "5689370" "5691855" "5715093" "5722836" "5724187" "5751489" "5760962" "5784211" "5786772" "5788357" "5790298") .PN.				
S14	137	("5790327" "5793542" "5796094" "5796532" "5805367" "5808777" "5823654" "5825527" "5835294" "5838505" "5847889" "5863116" "5864434" "5877897" "5910854" "5922176" "5929786" "5938320" "5980050" "6001486" "6002511" "6005724" "6007207" "6030084" "6032323" "6033078" "6065840" "6074068" "6097023" "6109586" "6111684" "6116743" "6124647" "6128860" "6154306" "6164564" "6172613" "6176602" "6178034" "6196688" "6198409" "6199993" "6201642" "6207083" "6227689" "6245262" "6250148" "6257746" "6260608" "6270225" "6276821" "6286965" "6294989" "6310611" "6315419" "6318870" "6320282" "6329925" "6341523" "6343402" "6356376" "6390632" "6396397" "6398377" "6409354" "6420036" "6428172" "6441964" "6445287" "6449082" "6472979" "6498620" "6501387" "6511192" "6512624" "6522451" "6537138" "6582109" "6595649" "6615438" "6627918" "6642851" "6648477" "6669109" "6690268" "6709119" "6717610" "6717712" "6719215" "6731205" "6737629" "6742904" "6757109" "6824281" "6831268" "6882287" "6919796" "6932483" "6979090" "7001032" "7005974" "7025469" "7038577" "7097312" "7106392" "7126456" "7167294" "7168830" "7184190" "7195381" "7249860" "7255451" "7267448" "7274501" "7289037" "7338177" "7339149" "7345680" "7370983" "7377675" "7391563" "7400435" "7420756" "7423522" "7492281" "7526103" "7581859" "7626749" "7636188" "7857469" "7934843" "8267534" "8562157" "D297926" "D493131" "D493394" "RE17274") .pn.	US- PGPUB; USPAT	ADJ	ON	2013/12/05 14:53
S15	385	S13 or S14	US- PGPUB; USPAT	ADJ	ON	2013/12/05 14:53

S16	130	S15 and (plano or planar) and (curv\$ or non?plano or non?planar)	US-PGPUB; USPAT	ADJ	ON	2013/12/05 14:53
S17	4	13/776,247.app. or 13/776,091.app.	US-PGPUB; USPAT	ADJ	ON	2013/12/05 15:09
S18	12	13/590,854.app. or 13/336,018.app. or 12/911,274.app. or 12/851,045.app. or 12/197,666.app. or 10/709,434.app.	US-PGPUB; USPAT	ADJ	ON	2013/12/05 15:11
S19	8	S18 and overlap\$	US-PGPUB; USPAT	ADJ	ON	2013/12/05 15:11
S20	2	12/197,666.app.	US-PGPUB; USPAT	ADJ	ON	2013/12/05 15:13
S21	16	13/776,247.app. or 13/776,091.app. or 13/590,854.app. or 13/336,018.app. or 12/911,274.app. or 12/851,045.app. or 12/197,666.app. or 10/709,434.app.	US-PGPUB; USPAT	ADJ	ON	2013/12/05 15:24
S24	1	"20020072026".pn.	US-PGPUB; USPAT	ADJ	ON	2013/12/05 15:30
S25	16	S21 and auxiliary	US-PGPUB; USPAT	ADJ	ON	2013/12/05 15:51
S26	4536	248/466-498.ccls.	US-PGPUB; USPAT	ADJ	ON	2013/12/05 21:01
S27	1266	S26 and (vehide or automobile or car or truck or van)	US-PGPUB; USPAT	ADJ	ON	2013/12/05 21:02
S28	91	S27 and (plano or planar) and (curv\$ or non?plano or non?planar)	US-PGPUB; USPAT	ADJ	ON	2013/12/05 21:02
S29	75	(US-20030039039-\$ or US-20020105741-\$ or US-20130188237-\$ or US-20120314316-\$ or US-20110170207-\$ or US-20110157732-\$ or US-20100296187-\$ or US-20100195228-\$ or US-20090268321-\$ or US-20090237820-\$ or US-20090040306-\$ or US-20080308219-\$ or US-20080304170-\$ or US-20080225421-\$ or US-20080212189-\$ or US-20060279863-\$ or US-20060268440-\$ or US-20040264011-\$ or US-20040257685-\$ or US-20040165291-\$ or US-20040114260-\$ or US-20030117731-\$ or US-20030031023-\$ or US-20030026012-\$ or US-20020072026-\$ or US-20090115631-\$).did. or (US-20050248859-\$).did. or (US-6522451-\$ or US-5579133-\$ or US-4331382-\$ or US-8562157-\$ or US-7934843-\$ or US-7626749-\$ or US-7420756-\$ or US-7097312-\$ or US-6717712-\$ or US-8267534-\$ or US-7857469-\$ or US-7636188-\$ or US-7391563-\$ or US-7167294-\$ or US-7255451-\$ or US-7126456-\$ or US-7001032-\$ or US-6919796-\$ or US-6511192-\$ or US-	US-PGPUB; USPAT	ADJ	ON	2013/12/05 21:03

		6398377-\$ or US-6343402-\$ or US-6315419-\$ or US-6199993-\$ or US-5847889-\$ or US-5793542-\$ or US-5790327-\$).did. or (US-5784211-\$ or US-5296973-\$ or US-5295021-\$ or US-5166833-\$ or US-5085907-\$ or US-5005962-\$ or US-4906075-\$ or US-D297926-\$ or US-4715701-\$ or US-4549786-\$ or US-4526446-\$ or US-4311363-\$ or US-4303308-\$ or US-4293191-\$ or US-4268120-\$ or US-4223983-\$ or US-4200359-\$ or US-3408136-\$ or US-3389952-\$ or US-3375053-\$ or US-2911177-\$ or US-1114559-\$).did.				
S30	27	S29 and overlap\$	US-PGPUB; USPAT	ADJ	ON	2013/12/05 21:04
S31	23	S30 and (plano or planar) and (curv\$ or non?plano or non?planar)	US-PGPUB; USPAT	ADJ	ON	2013/12/05 21:04
S32	248	"1114559" "1672559" "2135262" "2263382" "2279751" "2514989" "2580014" "2636419" "2778273" "2890539" "2911177" "20020036828" "20020048100" "20020072026" "20020105741" "20020159169" "20020159270" "20030026009" "20030026012" "20030031023" "20030043589" "20030117731" "20040032638" "20040032675" "20040032676" "20040114260" "20040165291" "20040257685" "20040264011" "20050078389" "20050083577" "20050099693" "20050134983" "20050232469" "20050248859" "20060050018" "20060061008" "20060125919" "20060126150" "20060171704" "20060184297" "20060268440" "20060279863" "20070058257" "20070285789" "20080212189" "20080225421" "20080304170" "20080308219" "20090040306" "20090115631" "20090237820" "20090268321" "20100195228" "20100296187" "20110157732" "20110170207" "20120314316" "20130188237" "20130188269" "3104274" "3131250" "3146296" "3170985" "3175463" "3266016" "3267806" "3280701" "3337285" "3338655" "3375053" "3389952" "3404935" "3408136" "3424517" "3563638" "3601614" "3610739" "3667833" "3708222" "3759647" "3764201" "3773882" "3806232" "3826563" "3881811" "3884606" "3909117" "4193668" "4200359" "4223983" "4258979" "4264144" "4268120" "4281899" "4293191" "4303308" "4306770" "4311362" "4311363" "4325609" "4331382"	US-PGPUB; USPAT	ADJ	ON	2013/12/05 21:04

		"4350412"	"4385804"	"4435042"				
		"4436371"	"4436372"	"4439013"				
		"4449786"	"4470665"	"4499451"				
		"4526446"	"4549786"	"4555166"				
		"4575202"	"4588267"	"4609266"				
		"4623222"	"4629296"	"4630904"				
		"4666264"	"4674849"	"4674850"				
		"4678294"	"4679906"	"4712879"				
		"4715701"	"4721364"	"4727302"				
		"4733336"	"4737188"	"4770522"				
		"4773740"	"4793690"	"4799768"				
		"4824231"	"4826289"	"4828379"				
		"4853283"	"4859046"	"4882466"				
		"4882565"	"4906075"	"4906085"				
		"4913542"	"4917485"	"4929074"				
		"4932769"	"4932770"	"4944581"				
		"4948242"	"4989964"	"5005962"				
		"5014167"	"5022747"	"5033835"				
		"5044739"	"5050977"	"5052792"				
		"5066112"	"5073012"	"5076673"				
		"5078480"	"5080492"	"5085907"				
		"5107374"	"5115346"	"5115352"				
		"5117346"	"5118540"	"5140455"				
		"5142407"	"5151816"	"5151824"				
		"5166833"	"5178448"	"5179471"				
		"5183099"	"5189537"	"5193029"				
		"5207492"	"5225943"	"5233461"				
		"5237458"	"5237459"	"5239405"				
		"5247395"	"5253109"	"5262894"				
		"5285060"	"5295021"	"5296973"				
		"5313335"	"5327288"	"5354965"				
		"5355245"	"5361172"	"5371659"				
		"5406414"	"5412512"	"5424875"				
		"5432643"	"5437931"	"5446576"				
		"5481409"	"5483386"	"5497305"				
		"5497306"	"5509606"	"5517367"				
		"5523877"	"5525264"	"5526195"				
		"5530588"	"5535056"	"5550677"				
		"5557467"	"5559640"	"5563744"				
		"5567360"	"5575552"	"5579133"				
		"5587236"	"5587699"	"5594222"				
		"5594593"	"5610756"	"5621569"				
		"5621577"	"5644442"	"5649756"				
		"5668663"	"5669698"	"5669699"				
		"5669704"	"5669705"	"5670935"				
		"5689370"	"5691855"	"5715093"				
		"5722836"	"5724187"	"5751489"				
		"5760962"	"5784211"	"5786772"				
		"5788357"	"5790298")	PN.				
S33	137	("5790327"	"5793542"	"5796094"	US-	ADJ	ON	2013/12/05
		"5796532"	"5805367"	"5808777"	PGPUB;			21:04
		"5823654"	"5825527"	"5835294"	USPAT			
		"5838505"	"5847889"	"5863116"				
		"5864434"	"5877897"	"5910854"				
		"5922176"	"5929786"	"5938320"				
		"5980050"	"6001486"	"6002511"				
		"6005724"	"6007207"	"6030084"				
		"6032323"	"6033078"	"6065840"				
		"6074068"	"6097023"	"6109586"				
		"6111684"	"6116743"	"6124647"				
		"6128860"	"6154306"	"6164564"				
		"6172613"	"6176602"	"6178034"				
		"6196688"	"6198409"	"6199993"				
		"6201642"	"6207083"	"6227689"				

		"6245262" "6250148" "6257746" "6260608" "6270225" "6276821" "6286965" "6294989" "6310611" "6315419" "6318870" "6320282" "6329925" "6341523" "6343402" "6356376" "6390632" "6396397" "6398377" "6409354" "6420036" "6428172" "6441964" "6445287" "6449082" "6472979" "6498620" "6501387" "6511192" "6512624" "6522451" "6537138" "6582109" "6595649" "6615438" "6627918" "6642851" "6648477" "6669109" "6690268" "6709119" "6717610" "6717712" "6719215" "6731205" "6737629" "6742904" "6757109" "6824281" "6831268" "6882287" "6919796" "6932483" "6979090" "7001032" "7005974" "7025469" "7038577" "7097312" "7106392" "7126456" "7167294" "7168830" "7184190" "7195381" "7249860" "7255451" "7267448" "7274501" "7289037" "7338177" "7339149" "7345680" "7370983" "7377675" "7391563" "7400435" "7420756" "7423522" "7492281" "7526103" "7581859" "7626749" "7636188" "7857469" "7934843" "8267534" "8562157" "D297926" "D493131" "D493394" "RE17274") .pn.				
S34	385	S32 or S33	US- PGPUB; USPAT	ADJ	ON	2013/12/05 21:04
S35	89	S34 and overlap\$	US- PGPUB; USPAT	ADJ	ON	2013/12/05 21:05
S36	52	S35 and (plano or planar) and (curv\$ or non?plano or non?planar)	US- PGPUB; USPAT	ADJ	ON	2013/12/05 21:05
S37	16	13/776,247.app. or 13/776,091.app. or 13/590,854.app. or 13/336,018.app. or 12/911,274.app. or 12/851,045.app. or 12/197,666.app. or 10/709,434.app.	US- PGPUB; USPAT	ADJ	ON	2013/12/05 21:08
S38	6	S37 and overlap\$.clm.	US- PGPUB; USPAT	ADJ	ON	2013/12/05 21:08
S41	8654	B60R1/\$.cpc.	US- PGPUB; USPAT	ADJ	ON	2014/05/13 07:21
S42	345316	(plano or planar) and (curv\$ or non?plano or non?planar)	US- PGPUB; USPAT	ADJ	ON	2014/05/13 07:21
S43	983	S41 and S42	US- PGPUB; USPAT	ADJ	ON	2014/05/13 07:21
S44	110	"4,449,786"	US- PGPUB; USPAT	ADJ	ON	2014/05/13 07:23
S45	1	"4,449,786".pn.	US-	ADJ	ON	2014/05/13

			PGPUB; USPAT			07:23
S46	2361	G02B5/08\$.cpc.	US- PGPUB; USPAT	ADJ	ON	2014/05/13 07:42
S47	2175079	(vehicle or automobile or car or truck or van)	US- PGPUB; USPAT	ADJ	ON	2014/05/13 07:42
S48	594	S46 and S47	US- PGPUB; USPAT	ADJ	ON	2014/05/13 07:42
S49	142	S42 and S48	US- PGPUB; USPAT	ADJ	ON	2014/05/13 07:42
S50	1506	donnely.as.	US- PGPUB; USPAT	ADJ	ON	2014/05/13 07:43
S51	1453	S47 and S50	US- PGPUB; USPAT	ADJ	ON	2014/05/13 07:43
S52	476	S42 and S51	US- PGPUB; USPAT	ADJ	ON	2014/05/13 07:43
S53	152	S52 and overlap\$	US- PGPUB; USPAT	ADJ	ON	2014/05/13 07:48
S54	6426	359/838,850,864,868-869,871-878,881-884.ccls.	US- PGPUB; USPAT	ADJ	ON	2014/05/13 07:51
S55	3002	S54 and (vehicle or automobile or car or truck or van)	US- PGPUB; USPAT	ADJ	ON	2014/05/13 07:51
S56	452	S55 and (plano or planar) and (curv\$ or non?plano or non?planar)	US- PGPUB; USPAT	ADJ	ON	2014/05/13 07:51
S57	248	"1114559" "1672559" "2135262" "2263382" "2279751" "2514989" "2580014" "2636419" "2778273" "2890539" "2911177" "20020036828" "20020048100" "20020072026" "20020105741" "20020159169" "20020159270" "20030026009" "20030026012" "20030031023" "20030043589" "20030117731" "20040032638" "20040032675" "20040032676" "20040114260" "20040165291" "20040257685" "20040264011" "20050078389" "20050083577" "20050099693" "20050134983" "20050232469" "20050248859" "20060050018" "20060061008" "20060125919" "20060126150" "20060171704" "20060184297" "20060268440" "20060279863" "20070058257" "20070285789" "20080212189" "20080225421" "20080304170" "20080308219" "20090040306" "20090115631" "20090237820" "20090268321" "20100195228"	US- PGPUB; USPAT	ADJ	ON	2014/05/13 07:51

"20100296187"	"20110157732"	
"20110170207"	"20120314316"	
"20130188237"	"20130188269"	
"3104274"	"3131250"	"3146296"
"3170985"	"3175463"	"3266016"
"3267806"	"3280701"	"3337285"
"3338655"	"3375053"	"3389952"
"3404935"	"3408136"	"3424517"
"3563638"	"3601614"	"3610739"
"3667833"	"3708222"	"3759647"
"3764201"	"3773882"	"3806232"
"3826563"	"3881811"	"3884606"
"3909117"	"4193668"	"4200359"
"4223983"	"4258979"	"4264144"
"4268120"	"4281899"	"4293191"
"4303308"	"4306770"	"4311362"
"4311363"	"4325609"	"4331382"
"4350412"	"4385804"	"4435042"
"4436371"	"4436372"	"4439013"
"4449786"	"4470665"	"4499451"
"4526446"	"4549786"	"4555166"
"4575202"	"4588267"	"4609266"
"4623222"	"4629296"	"4630904"
"4666264"	"4674849"	"4674850"
"4678294"	"4679906"	"4712879"
"4715701"	"4721364"	"4727302"
"4733336"	"4737188"	"4770522"
"4773740"	"4793690"	"4799768"
"4824231"	"4826289"	"4828379"
"4853283"	"4859046"	"4882466"
"4882565"	"4906075"	"4906085"
"4913542"	"4917485"	"4929074"
"4932769"	"4932770"	"4944581"
"4948242"	"4989964"	"5005962"
"5014167"	"5022747"	"5033835"
"5044739"	"5050977"	"5052792"
"5066112"	"5073012"	"5076673"
"5078480"	"5080492"	"5085907"
"5107374"	"5115346"	"5115352"
"5117346"	"5118540"	"5140455"
"5142407"	"5151816"	"5151824"
"5166833"	"5178448"	"5179471"
"5183099"	"5189537"	"5193029"
"5207492"	"5225943"	"5233461"
"5237458"	"5237459"	"5239405"
"5247395"	"5253109"	"5262894"
"5285060"	"5295021"	"5296973"
"5313335"	"5327288"	"5354965"
"5355245"	"5361172"	"5371659"
"5406414"	"5412512"	"5424875"
"5432643"	"5437931"	"5446576"
"5481409"	"5483386"	"5497305"
"5497306"	"5509606"	"5517367"
"5523877"	"5525264"	"5526195"
"5530588"	"5535056"	"5550677"
"5557467"	"5559640"	"5563744"
"5567360"	"5575552"	"5579133"
"5587236"	"5587699"	"5594222"
"5594593"	"5610756"	"5621569"
"5621577"	"5644442"	"5649756"
"5668663"	"5669698"	"5669699"
"5669704"	"5669705"	"5670935"
"5689370"	"5691855"	"5715093"
"5722836"	"5724187"	"5751489"

		"5760962" "5784211" "5786772" "5788357" "5790298"). PN.				
S58	137	("5790327" "5793542" "5796094" "5796532" "5805367" "5808777" "5823654" "5825527" "5835294" "5838505" "5847889" "5863116" "5864434" "5877897" "5910854" "5922176" "5929786" "5938320" "5980050" "6001486" "6002511" "6005724" "6007207" "6030084" "6032323" "6033078" "6065840" "6074068" "6097023" "6109586" "6111684" "6116743" "6124647" "6128860" "6154306" "6164564" "6172613" "6176602" "6178034" "6196688" "6198409" "6199993" "6201642" "6207083" "6227689" "6245262" "6250148" "6257746" "6260608" "6270225" "6276821" "6286965" "6294989" "6310611" "6315419" "6318870" "6320282" "6329925" "6341523" "6343402" "6356376" "6390632" "6396397" "6398377" "6409354" "6420036" "6428172" "6441964" "6445287" "6449082" "6472979" "6498620" "6501387" "6511192" "6512624" "6522451" "6537138" "6582109" "6595649" "6615438" "6627918" "6642851" "6648477" "6669109" "6690268" "6709119" "6717610" "6717712" "6719215" "6731205" "6737629" "6742904" "6757109" "6824281" "6831268" "6882287" "6919796" "6932483" "6979090" "7001032" "7005974" "7025469" "7038577" "7097312" "7106392" "7126456" "7167294" "7168830" "7184190" "7195381" "7249860" "7255451" "7267448" "7274501" "7289037" "7338177" "7339149" "7345680" "7370983" "7377675" "7391563" "7400435" "7420756" "7423522" "7492281" "7526103" "7581859" "7626749" "7636188" "7857469" "7934843" "8267534" "8562157" "D297926" "D493131" "D493394" "RE17274"). pn.	US- PGPUB; USPAT	ADJ	ON	2014/05/13 07:51
S59	385	S57 or S58	US- PGPUB; USPAT	ADJ	ON	2014/05/13 07:51
S60	130	S59 and (plano or planar) and (curv\$ or non?plano or non?planar)	US- PGPUB; USPAT	ADJ	ON	2014/05/13 07:51
S61	4579	248/466-498.ccls.	US- PGPUB; USPAT	ADJ	ON	2014/05/13 07:51
S62	1286	S61 and (vehicle or automobile or car or truck or van)	US- PGPUB; USPAT	ADJ	ON	2014/05/13 07:51
S63	91	S62 and (plano or planar) and (curv\$ or non?plano or non?planar)	US- PGPUB;	ADJ	ON	2014/05/13 07:51

EAST Search History

			USPAT			
S64	17	(S56 or S60 or S63) and @pd> = "20131205"	US-PGPUB; USPAT	ADJ	ON	2014/05/13 07:51

EAST Search History (Interference)

Ref #	Hits	Search Query	DBs	Default Operator	Plurals	Time Stamp
S39	2	(mirror and housing and plate and (plano or planar) and curv\$ and actuat\$3 and overlap\$ and field and view and superimpos\$).clm.	US-PGPUB; USPAT; UPAD	ADJ	ON	2013/12/05 21:00
S40	1	"Term Removed"	US-PGPUB	ADJ	ON	2013/12/05 21:03
S65	3	(mirror and housing and plate and (plano or planar) and curv\$ and actuat\$3 and overlap\$ and field and view and superimpos\$).clm.	US-PGPUB; USPAT; UPAD	ADJ	ON	2014/05/13 07:53

5/ 14/ 2014 8:33:09 AM

C:\Users\kkakalec\Documents\EAST\Workspaces\14054004.wsp

PART B - FEE(S) TRANSMITTAL

**Complete and send this form, together with applicable fee(s), to: Mail Mail Stop ISSUE FEE
 Commissioner for Patents
 P.O. Box 1450
 Alexandria, Virginia 22313-1450
 or Fax (571)-273-2885**

INSTRUCTIONS: This form should be used for transmitting the ISSUE FEE and PUBLICATION FEE (if required). Blocks 1 through 5 should be completed where appropriate. All further correspondence including the Patent, advance orders and notification of maintenance fees will be mailed to the current correspondence address as indicated unless corrected below or directed otherwise in Block 1, by (a) specifying a new correspondence address; and/or (b) indicating a separate "FEE ADDRESS" for maintenance fee notifications.

CURRENT CORRESPONDENCE ADDRESS (Note: Use Block 1 for any change of address)

15671 7590 06/10/2014
 Gardner, Linn, Burkhardt & Flory, LLP
 2851 Charlevoix Dr., SE, Suite 207
 Grand Rapids, MI 49546

Note: A certificate of mailing can only be used for domestic mailings of the Fee(s) Transmittal. This certificate cannot be used for any other accompanying papers. Each additional paper, such as an assignment or formal drawing, must have its own certificate of mailing or transmission.

Certificate of Mailing or Transmission

I hereby certify that this Fee(s) Transmittal is being deposited with the United States Postal Service with sufficient postage for first class mail in an envelope addressed to the Mail Stop ISSUE FEE address above, or being facsimile transmitted to the USPTO (571) 273-2885, on the date indicated below.

Amanda R. Sytsma	(Depositor's name)
/ars/	(Signature)
June 11, 2014	(Date)

APPLICATION NO.	FILING DATE	FIRST NAMED INVENTOR	ATTORNEY DOCKET NO.	CONFIRMATION NO.
14/054,004	10/15/2013	Niall R. Lynam	DON09 P-2194	4390

TITLE OF INVENTION: EXTENDED FIELD OF VIEW EXTERIOR MIRROR ELEMENT FOR VEHICLE

APPLN. TYPE	ENTITY STATUS	ISSUE FEE DUE	PUBLICATION FEE DUE	PREV. PAID ISSUE FEE	TOTAL FEE(S) DUE	DATE DUE
nonprovisional	UNDISCOUNTED	\$960	\$0	\$0	\$960	09/10/2014

EXAMINER	ART UNIT	CLASS-SUBCLASS
KAKALEC, KIMBERLY N	2872	359-866000

<p>1. Change of correspondence address or indication of "Fee Address" (37 CFR 1.363).</p> <p><input type="checkbox"/> Change of correspondence address (or Change of Correspondence Address form PTO/SB/122) attached.</p> <p><input type="checkbox"/> "Fee Address" indication (or "Fee Address" Indication form PTO/SB/47; Rev 03-02 or more recent) attached. Use of a Customer Number is required.</p>	<p>2. For printing on the patent front page, list <u>GARDNER, LINN, BURKHART & FLORY, LLP</u></p> <p>(1) The names of up to 3 registered patent attorneys or agents OR, alternatively, _____</p> <p>(2) The name of a single firm (having as a member a registered attorney or agent) and the names of up to 2 registered patent attorneys or agents. If no name is listed, no name will be printed. _____</p>
---	--

3. ASSIGNEE NAME AND RESIDENCE DATA TO BE PRINTED ON THE PATENT (print or type)

PLEASE NOTE: Unless an assignee is identified below, no assignee data will appear on the patent. If an assignee is identified below, the document has been filed for recordation as set forth in 37 CFR 3.111. Completion of this form is NOT a substitute for filing an assignment.

(A) NAME OF ASSIGNEE: DONNELLY CORPORATION

(B) RESIDENCE: (CITY and STATE OR COUNTRY) HOLLAND, MI

Please check the appropriate assignee category or categories (will not be printed on the patent): Individual Corporation or other private group entity Government

<p>4a. The following fee(s) are submitted:</p> <p><input checked="" type="checkbox"/> Issue Fee</p> <p><input type="checkbox"/> Publication Fee (No small entity discount permitted)</p> <p><input type="checkbox"/> Advance Order - # of Copies _____</p>	<p>4b. Payment of Fee(s): (Please first reapply any previously paid issue fee shown above)</p> <p><input type="checkbox"/> A check is enclosed.</p> <p><input type="checkbox"/> Payment by credit card. Form PTO-2038 is attached.</p> <p><input checked="" type="checkbox"/> The Director is hereby authorized to charge the required fee(s), any deficiency, or credits any overpayment, to Deposit Account Number <u>50-5553</u> (enclose an extra copy of this form).</p>
--	--

5. **Change in Entity Status** (from status indicated above)

Applicant certifying micro entity status. See 37 CFR 1.29

Applicant asserting small entity status. See 37 CFR 1.27

Applicant changing to regular undiscounted fee status.

NOTE: Absent a valid certification of Micro Entity Status (see forms PTO/SB/15A and 15B), issue fee payment in the micro entity amount will not be accepted at the risk of application abandonment.

NOTE: If the application was previously under micro entity status, checking this box will be taken to be a notification of loss of entitlement to micro entity status.

NOTE: Checking this box will be taken to be a notification of loss of entitlement to small or micro entity status, as applicable.

NOTE: This form must be signed in accordance with 37 CFR 1.31 and 1.33. See 37 CFR 1.4 for signature requirements and certifications.

Authorized Signature  Date June 11, 2014

Typed or printed name Timothy A. Flory Registration No. 42540

Electronic Patent Application Fee Transmittal

Application Number:	14054004			
Filing Date:	15-Oct-2013			
Title of Invention:	EXTENDED FIELD OF VIEW EXTERIOR MIRROR ELEMENT FOR VEHICLE			
First Named Inventor/Applicant Name:	Niall R. Lynam			
Filer:	Timothy A. Flory/Amanda Sytsma			
Attorney Docket Number:	DON09 P-2194			
Filed as Large Entity				
Utility under 35 USC 111(a) Filing Fees				
Description	Fee Code	Quantity	Amount	Sub-Total in USD(\$)
Basic Filing:				
Pages:				
Claims:				
Miscellaneous-Filing:				
Petition:				
Patent-Appeals-and-Interference:				
Post-Allowance-and-Post-Issuance:				
Utility Appl Issue Fee	1501	1	960	960
Extension-of-Time:				

Description	Fee Code	Quantity	Amount	Sub-Total in USD(\$)
Miscellaneous:				
Total in USD (\$)				960

Electronic Acknowledgement Receipt

EFS ID:	19268180
Application Number:	14054004
International Application Number:	
Confirmation Number:	4390
Title of Invention:	EXTENDED FIELD OF VIEW EXTERIOR MIRROR ELEMENT FOR VEHICLE
First Named Inventor/Applicant Name:	Niall R. Lynam
Customer Number:	15671
Filer:	Timothy A. Flory/Amanda Sytsma
Filer Authorized By:	Timothy A. Flory
Attorney Docket Number:	DON09 P-2194
Receipt Date:	11-JUN-2014
Filing Date:	15-OCT-2013
Time Stamp:	11:09:43
Application Type:	Utility under 35 USC 111(a)

Payment information:

Submitted with Payment	yes
Payment Type	Credit Card
Payment was successfully received in RAM	\$960
RAM confirmation Number	8621
Deposit Account	
Authorized User	

File Listing:

Document Number	Document Description	File Name	File Size(Bytes)/ Message Digest	Multi Part /.zip	Pages (if appl.)
-----------------	----------------------	-----------	-------------------------------------	------------------	------------------

1	Issue Fee Payment (PTO-85B)	IssueFeeTransmittal.pdf	168423	no	1
			47651f8bd42b4936a6007821a14ead9771508b8		
Warnings:					
Information:					
2	Fee Worksheet (SB06)	fee-info.pdf	30286	no	2
			317524be7c754315a77724f6a07db576f13134da		
Warnings:					
Information:					
Total Files Size (in bytes):				198709	
<p>This Acknowledgement Receipt evidences receipt on the noted date by the USPTO of the indicated documents, characterized by the applicant, and including page counts, where applicable. It serves as evidence of receipt similar to a Post Card, as described in MPEP 503.</p> <p><u>New Applications Under 35 U.S.C. 111</u> If a new application is being filed and the application includes the necessary components for a filing date (see 37 CFR 1.53(b)-(d) and MPEP 506), a Filing Receipt (37 CFR 1.54) will be issued in due course and the date shown on this Acknowledgement Receipt will establish the filing date of the application.</p> <p><u>National Stage of an International Application under 35 U.S.C. 371</u> If a timely submission to enter the national stage of an international application is compliant with the conditions of 35 U.S.C. 371 and other applicable requirements a Form PCT/DO/EO/903 indicating acceptance of the application as a national stage submission under 35 U.S.C. 371 will be issued in addition to the Filing Receipt, in due course.</p> <p><u>New International Application Filed with the USPTO as a Receiving Office</u> If a new international application is being filed and the international application includes the necessary components for an international filing date (see PCT Article 11 and MPEP 1810), a Notification of the International Application Number and of the International Filing Date (Form PCT/RO/105) will be issued in due course, subject to prescriptions concerning national security, and the date shown on this Acknowledgement Receipt will establish the international filing date of the application.</p>					



UNITED STATES PATENT AND TRADEMARK OFFICE

UNITED STATES DEPARTMENT OF COMMERCE
United States Patent and Trademark Office
Address: COMMISSIONER FOR PATENTS
P. O. Box 1450
Alexandria, Virginia 22313-1450
www.uspto.gov

APPLICATION NO.	ISSUE DATE	PATENT NO.	ATTORNEY DOCKET NO.	CONFIRMATION NO.
14/054,004	07/22/2014	8783882	DON09 P-2194	4390

15671 7590 07/02/2014
Gardner, Linn, Burkhardt & Flory, LLP
2851 Charlevoix Dr., SE, Suite 207
Grand Rapids, MI 49546

ISSUE NOTIFICATION

The projected patent number and issue date are specified above.

Determination of Patent Term Adjustment under 35 U.S.C. 154 (b)
(application filed on or after May 29, 2000)

The Patent Term Adjustment is 0 day(s). Any patent to issue from the above-identified application will include an indication of the adjustment on the front page.

If a Continued Prosecution Application (CPA) was filed in the above-identified application, the filing date that determines Patent Term Adjustment is the filing date of the most recent CPA.

Applicant will be able to obtain more detailed information by accessing the Patent Application Information Retrieval (PAIR) WEB site (<http://pair.uspto.gov>).

Any questions regarding the Patent Term Extension or Adjustment determination should be directed to the Office of Patent Legal Administration at (571)-272-7702. Questions relating to issue and publication fee payments should be directed to the Application Assistance Unit (AAU) of the Office of Data Management (ODM) at (571)-272-4200.

APPLICANT(s) (Please see PAIR WEB site <http://pair.uspto.gov> for additional applicants):

Donnelly Corporation, Holland, MI, Assignee (with 37 CFR 1.172 Interest);
Niall R. Lynam, Holland, MI;

The United States represents the largest, most dynamic marketplace in the world and is an unparalleled location for business investment, innovation, and commercialization of new technologies. The USA offers tremendous resources and advantages for those who invest and manufacture goods here. Through SelectUSA, our nation works to encourage and facilitate business investment. To learn more about why the USA is the best country in the world to develop technology, manufacture products, and grow your business, visit SelectUSA.gov.

UNITED STATES PATENT AND TRADEMARK OFFICE CERTIFICATE OF CORRECTION

Page 1 of 1

PATENT NO. : 8,783,882

APPLICATION NO.: 14/054,004

ISSUE DATE : July 22, 2014

INVENTOR(S) : Niall R. Lynam

It is certified that an error appears or errors appear in the above-identified patent and that said Letters Patent is hereby corrected as shown below:

Column 7

Lines 6-7, "ejectrochromic" should be --electrochromic--
 Line 9, "plano-muitiradius" should be --plano-multiradius--
 Line 21, "rearwardiy" should be --rearwardly--
 Line 49, "rearwardiy" should be --rearwardly--

Column 28

Line 60, Insert --%-- after "80"

Column 32

Line 9, "embodiment" should be --embodiments--

MAILING ADDRESS OF SENDER (Please do not use customer number below):

GARDNER, LINN, BURKHART & FLORY, LLP
 2851 Charlevoix Dr., S.E., Suite 207
 Grand Rapids, MI 49546

This collection of information is required by 37 CFR 1.322, 1.323, and 1.324. The information is required to obtain or retain a benefit by the public which is to file (and by the USPTO to process) an application. Confidentiality is governed by 35 U.S.C. 122 and 37 CFR 1.14. This collection is estimated to take 1.0 hour to complete, including gathering, preparing, and submitting the completed application form to the USPTO. Time will vary depending upon the individual case. Any comments on the amount of time you require to complete this form and/or suggestions for reducing this burden, should be sent to the Chief Information Officer, U.S. Patent and Trademark Office, U.S. Department of Commerce, P.O. Box 1450, Alexandria, VA 22313-1450. DO NOT SEND FEES OR COMPLETED FORMS TO THIS ADDRESS. SEND TO: **Attention Certificate of Corrections Branch, Commissioner for Patents, P.O. Box 1450, Alexandria, VA 22313-1450.**

If you need assistance in completing the form, call 1-800-PTO-9199 and select option 2.

Electronic Acknowledgement Receipt

EFS ID:	21986706
Application Number:	14054004
International Application Number:	
Confirmation Number:	4390
Title of Invention:	EXTENDED FIELD OF VIEW EXTERIOR MIRROR ELEMENT FOR VEHICLE
First Named Inventor/Applicant Name:	Niall R. Lynam
Customer Number:	15671
Filer:	Timothy A. Flory/Amanda Sytsma
Filer Authorized By:	Timothy A. Flory
Attorney Docket Number:	DON09 P-2194
Receipt Date:	07-APR-2015
Filing Date:	15-OCT-2013
Time Stamp:	08:21:27
Application Type:	Utility under 35 USC 111(a)

Payment information:

Submitted with Payment	no
------------------------	----

File Listing:

Document Number	Document Description	File Name	File Size(Bytes)/ Message Digest	Multi Part /.zip	Pages (if appl.)
1	Transmittal Letter	P2194TransmittalForm.pdf	129049 697bcfaf9813ade328246c1ec292b09e5ce857c2	no	1

Warnings:

Information:

2	Request for Certificate of Correction	P2194RequestforCertificateofCorrection.pdf	93510 63efcaa9aefad86a9f8a5e1276151aa7e09b5829	no	1
---	---------------------------------------	--	---	----	---

Warnings:

Information:

Total Files Size (in bytes):	222559
-------------------------------------	--------

This Acknowledgement Receipt evidences receipt on the noted date by the USPTO of the indicated documents, characterized by the applicant, and including page counts, where applicable. It serves as evidence of receipt similar to a Post Card, as described in MPEP 503.

New Applications Under 35 U.S.C. 111

If a new application is being filed and the application includes the necessary components for a filing date (see 37 CFR 1.53(b)-(d) and MPEP 506), a Filing Receipt (37 CFR 1.54) will be issued in due course and the date shown on this Acknowledgement Receipt will establish the filing date of the application.

National Stage of an International Application under 35 U.S.C. 371

If a timely submission to enter the national stage of an international application is compliant with the conditions of 35 U.S.C. 371 and other applicable requirements a Form PCT/DO/EO/903 indicating acceptance of the application as a national stage submission under 35 U.S.C. 371 will be issued in addition to the Filing Receipt, in due course.

New International Application Filed with the USPTO as a Receiving Office

If a new international application is being filed and the international application includes the necessary components for an international filing date (see PCT Article 11 and MPEP 1810), a Notification of the International Application Number and of the International Filing Date (Form PCT/RO/105) will be issued in due course, subject to prescriptions concerning national security, and the date shown on this Acknowledgement Receipt will establish the international filing date of the application.

Under the Paperwork Reduction Act of 1995, no persons are required to respond to a collection of information unless it displays a valid OMB control number.

TRANSMITTAL FORM <small>(to be used for all correspondence after initial filing)</small>	Application Number	14/054,004
	Filing Date	October 15, 2013
	First Named Inventor	Niall R. Lynam
	Art Unit	2872
	Examiner Name	Kimberly N. Kakalec
Total Number of Pages in This Submission	Attorney Docket Number	DON09 P-2194

ENCLOSURES (Check all that apply)				
<input type="checkbox"/> Fee Transmittal Form <input type="checkbox"/> Fee Attached <input type="checkbox"/> Amendment/Reply <input type="checkbox"/> After Final <input type="checkbox"/> Affidavits/declaration(s) <input type="checkbox"/> Extension of Time Request <input type="checkbox"/> Express Abandonment Request <input type="checkbox"/> Information Disclosure Statement <input type="checkbox"/> Certified Copy of Priority Document(s) <input type="checkbox"/> Reply to Missing Parts/ Incomplete Application <input type="checkbox"/> Reply to Missing Parts under 37 CFR 1.52 or 1.53	<input type="checkbox"/> Drawing(s) <input type="checkbox"/> Licensing-related Papers <input type="checkbox"/> Petition <input type="checkbox"/> Petition to Convert to a Provisional Application <input type="checkbox"/> Power of Attorney, Revocation <input type="checkbox"/> Change of Correspondence Address <input type="checkbox"/> Terminal Disclaimer <input type="checkbox"/> Request for Refund <input type="checkbox"/> CD, Number of CD(s) _____ <input type="checkbox"/> Landscape Table on CD	<input type="checkbox"/> After Allowance Communication to TC <input type="checkbox"/> Appeal Communication to Board of Appeals and Interferences <input type="checkbox"/> Appeal Communication to TC (Appeal Notice, Brief, Reply Brief) <input type="checkbox"/> Proprietary Information <input type="checkbox"/> Status Letter <input checked="" type="checkbox"/> Other Enclosure(s) (please identify below): -Request for Certificate of Correction		
<table border="1" style="width: 100%; border-collapse: collapse;"> <tr> <td style="width: 100px;">Remarks</td> <td></td> </tr> </table>			Remarks	
Remarks				

SIGNATURE OF APPLICANT, ATTORNEY, OR AGENT			
Firm Name	GARDNER, LINN, BURKHART & FLORY, LLP		
Signature	/taf/		
Printed name	Timothy A. Flory		
Date	April 7, 2015	Reg. No.	42540

CERTIFICATE OF TRANSMISSION/MAILING			
I hereby certify that this correspondence is being facsimile transmitted to the USPTO or deposited with the United States Postal Service with sufficient postage as first class mail in an envelope addressed to: Commissioner for Patents, P.O. Box 1450, Alexandria, VA 22313-1450 on the date shown below:			
Signature	/ars/		
Typed or printed name	Amanda R. Sytsma	Date	April 7, 2015

This collection of information is required by 37 CFR 1.5. The information is required to obtain or retain a benefit by the public which is to file (and by the USPTO to process) an application. Confidentiality is governed by 35 U.S.C. 122 and 37 CFR 1.11 and 1.14. This collection is estimated to 2 hours to complete, including gathering, preparing, and submitting the completed application form to the USPTO. Time will vary depending upon the individual case. Any comments on the amount of time you require to complete this form and/or suggestions for reducing this burden, should be sent to the Chief Information Officer, U.S. Patent and Trademark Office, U.S. Department of Commerce, P.O. Box 1450, Alexandria, VA 22313-1450. DO NOT SEND FEES OR COMPLETED FORMS TO THIS ADDRESS. SEND TO: **Commissioner for Patents, P.O. Box 1450, Alexandria, VA 22313-1450.**

If you need assistance in completing the form, call 1-800-PTO-9199 and select option 2.

AO 120 (Rev. 08/10)

TO: Mail Stop 8 Director of the U.S. Patent and Trademark Office P.O. Box 1450 Alexandria, VA 22313-1450	REPORT ON THE FILING OR DETERMINATION OF AN ACTION REGARDING A PATENT OR TRADEMARK
---	---

In Compliance with 35 U.S.C. § 290 and/or 15 U.S.C. § 1116 you are hereby advised that a court action has been filed in the U.S. District Court Western District of Michigan on the following

Trademarks or Patents. (the patent action involves 35 U.S.C. § 292.):

DOCKET NO. 1:15-cv-183	DATE FILED 2/19/2015	U.S. DISTRICT COURT Western District of Michigan
PLAINTIFF Magna Mirrors of America, Inc.		DEFENDANT Ficosa International S.A.; Ficosa North America Corporation; Ficosa North America S.A. de C.V.; and Fico Mirrors, S.A.
PATENT OR TRADEMARK NO.	DATE OF PATENT OR TRADEMARK	HOLDER OF PATENT OR TRADEMARK
1		SEE ATTCHED LIST
2		
3		
4		
5		

In the above—entitled case, the following patent(s)/ trademark(s) have been included:

DATE INCLUDED	INCLUDED BY <input type="checkbox"/> Amendment <input type="checkbox"/> Answer <input type="checkbox"/> Cross Bill <input type="checkbox"/> Other Pleading	
PATENT OR TRADEMARK NO.	DATE OF PATENT OR TRADEMARK	HOLDER OF PATENT OR TRADEMARK
1		
2		
3		
4		
5		

In the above—entitled case, the following decision has been rendered or judgement issued:

DECISION/JUDGEMENT

CLERK TRACEY CORDES, CLERK OF COURT	(BY) DEPUTY CLERK /s/ Paula J. Woods	DATE 2/20/1015
--	---	-------------------

Copy 1—Upon initiation of action, mail this copy to Director Copy 3—Upon termination of action, mail this copy to Director
 Copy 2—Upon filing document adding patent(s), mail this copy to Director Copy 4—Case file copy

Patent No.	Date of Patent	Holder
U.S. Patent 7,934,843	May 3, 2011	Magna Mirrors of America, Inc.
U.S. Patent 8,128,243	March 6, 2012	Magna Mirrors of America, Inc.
U.S. Patent 8,128,244	March 6, 2012	Magna Mirrors of America, Inc.
U.S. Patent 8,147,077	April 3, 2012	Magna Mirrors of America, Inc.
U.S. Patent 8,267,534	September 18, 2012	Magna Mirrors of America, Inc.
U.S. Patent 8,550,642	October 8, 2013	Magna Mirrors of America, Inc.
U.S. Patent 8,591,047	November 26, 2013	Magna Mirrors of America, Inc.
U.S. Patent 8,783,882	July 22, 2014	Magna Mirrors of America, Inc.
U.S. Patent 8,899,762	December 2, 2014	Magna Mirrors of America, Inc.

UNITED STATES PATENT AND TRADEMARK OFFICE
CERTIFICATE OF CORRECTION

PATENT NO. : 8,783,882 B2
APPLICATION NO. : 14/054004
DATED : July 22, 2014
INVENTOR(S) : Niall R. Lynam

Page 1 of 1

It is certified that error appears in the above-identified patent and that said Letters Patent is hereby corrected as shown below:

In the Specification

Column 7

Lines 6-7, "ejectrochromic" should be --electrochromic--
Line 9, "plano-muitiradius" should be --plano-multiradius--
Line 21, "rearwardiy" should be --rearwardly--
Line 49, "rearwardiy" should be --rearwardly--

Column 28

Line 60, Insert --%-- after "80"

In the Claims

Column 32

Line 9, "embodiment" should be --embodiments--

Signed and Sealed this
Thirtieth Day of June, 2015



Michelle K. Lee
Director of the United States Patent and Trademark Office

AO 120 (Rev. 08/10)

TO: Mail Stop 8 Director of the U.S. Patent and Trademark Office P.O. Box 1450 Alexandria, VA 22313-1450	REPORT ON THE FILING OR DETERMINATION OF AN ACTION REGARDING A PATENT OR TRADEMARK
---	--

In Compliance with 35 U.S.C. § 290 and/or 15 U.S.C. § 1116 you are hereby advised that a court action has been filed in the U.S. District Court Western District of Michigan on the following

Trademarks or Patents. (the patent action involves 35 U.S.C. § 292.);

DOCKET NO. 1:15-cv-183	DATE FILED 2/19/2015	U.S. DISTRICT COURT Western District of Michigan
PLAINTIFF Magna Mirrors of America, Inc.		DEFENDANT Ficosa International S.A., et al
PATENT OR TRADEMARK NO.	DATE OF PATENT OR TRADEMARK	HOLDER OF PATENT OR TRADEMARK
1		SEE ATTACHED LIST
2		
3		
4		
5		

In the above—entitled case, the following patent(s)/ trademark(s) have been included:

DATE INCLUDED	INCLUDED BY	<input type="checkbox"/> Amendment <input type="checkbox"/> Answer <input type="checkbox"/> Cross Bill <input type="checkbox"/> Other Pleading
PATENT OR TRADEMARK NO.	DATE OF PATENT OR TRADEMARK	HOLDER OF PATENT OR TRADEMARK
1		
2		
3		
4		
5		

In the above—entitled case, the following decision has been rendered or judgement issued:

DECISION/JUDGEMENT Voluntarily Dismissed on 3/23/2016
--

CLERK Clerk of Court	(BY) DEPUTY CLERK /s/ Paula J. Woods	DATE 3/24/2016
-------------------------	---	-------------------

Copy 1—Upon initiation of action, mail this copy to Director Copy 3—Upon termination of action, mail this copy to Director
 Copy 2—Upon filing document adding patent(s), mail this copy to Director Copy 4—Case file copy

Patent No.	Date of Patent	Holder
U.S. Patent 7,934,843	May 3, 2011	Magna Mirrors of America, Inc.
U.S. Patent 8,128,243	March 6, 2012	Magna Mirrors of America, Inc.
U.S. Patent 8,128,244	March 6, 2012	Magna Mirrors of America, Inc.
U.S. Patent 8,147,077	April 3, 2012	Magna Mirrors of America, Inc.
U.S. Patent 8,267,534	September 18, 2012	Magna Mirrors of America, Inc.
U.S. Patent 8,550,642	October 8, 2013	Magna Mirrors of America, Inc.
U.S. Patent 8,591,047	November 26, 2013	Magna Mirrors of America, Inc.
U.S. Patent 8,783,882	July 22, 2014	Magna Mirrors of America, Inc.
U.S. Patent 8,899,762	December 2, 2014	Magna Mirrors of America, Inc.

AO 120 (Rev. 08/10)

TO: Mail Stop 8 Director of the U.S. Patent and Trademark Office P.O. Box 1450 Alexandria, VA 22313-1450	REPORT ON THE FILING OR DETERMINATION OF AN ACTION REGARDING A PATENT OR TRADEMARK
---	--

In Compliance with 35 U.S.C. § 290 and/or 15 U.S.C. § 1116 you are hereby advised that a court action has been filed in the U.S. District Court Western District of Michigan on the following

Trademarks or Patents. (the patent action involves 35 U.S.C. § 292.);

DOCKET NO. 1:17-cv-77	DATE FILED 1/23/2017	U.S. DISTRICT COURT Western District of Michigan
PLAINTIFF MAGNA MIRRORS OF AMERICA, INC.		DEPENDANT SAMVARDHANA MOTHERSON REFLECTEC GROUP HOLDINGS LIMITED, et al.
PATENT OR TRADEMARK NO.	DATE OF PATENT OR TRADEMARK	HOLDER OF PATENT OR TRADEMARK
1		SEE ATTACHED
2		
3		
4		
5		

In the above—entitled case, the following patent(s)/ trademark(s) have been included:

DATE INCLUDED	INCLUDED BY <input type="checkbox"/> Amendment <input type="checkbox"/> Answer <input type="checkbox"/> Cross Bill <input type="checkbox"/> Other Pleading		
PATENT OR TRADEMARK NO.	DATE OF PATENT OR TRADEMARK	HOLDER OF PATENT OR TRADEMARK	
1			
2			
3			
4			
5			

In the above—entitled case, the following decision has been rendered or judgement issued:

DECISION/JUDGEMENT

CLERK Thomas L. Dorwin, Clerk of Court	(BY) DEPUTY CLERK /s/ P. Woods	DATE 1/25/2017
---	-----------------------------------	-------------------

Copy 1—Upon initiation of action, mail this copy to Director Copy 3—Upon termination of action, mail this copy to Director
 Copy 2—Upon filing document adding patent(s), mail this copy to Director Copy 4—Case file copy

Patent No.	Date of Patent	Holder
U.S. Patent 7,934,843	May 3, 2011	Magna Mirrors of America, Inc.
U.S. Patent 8,128,243	March 6, 2012	Magna Mirrors of America, Inc.
U.S. Patent 8,128,244	March 6, 2012	Magna Mirrors of America, Inc.
U.S. Patent 8,147,077	April 3, 2012	Magna Mirrors of America, Inc.
U.S. Patent 8,267,534	September 18, 2012	Magna Mirrors of America, Inc.
U.S. Patent 8,550,642	October 8, 2013	Magna Mirrors of America, Inc.
U.S. Patent 8,591,047	November 26, 2013	Magna Mirrors of America, Inc.
U.S. Patent 8,783,882	July 22, 2014	Magna Mirrors of America, Inc.
U.S. Patent 8,899,762	December 2, 2014	Magna Mirrors of America, Inc.