

SUBSTITUTE SHEET (RULE 26)

2. STATEMENT CONCERNING NON-PREJUDICIAL DISCLOSURES OR EXCEPTIONS TO LACK OF NOVELTY

Due to a possible disclosure by the inventors on or after October 1, 1998, the applicant respectfully requests that the subject international application be granted the respective provisions under National laws concerning Exceptions to Lack of Novelty in each of the designated countries. This is not an admission that the subject invention lacks novelty or inventive step over this disclosure. Exception to Lack of Novelty is hereby requested for purposes of disclosure and precautionary measures.

INTERNATIONAL SEARCH REPORT

International Application No
PCT/US 99/22709

A. CLASSIFICATION OF SUBJECT MATTER IPC 7 G06K9/00		
According to International Patent Classification (IPC) or to both national classification and IPC		
B. FIELDS SEARCHED		
Minimum documentation searched (classification system followed by classification symbols) IPC 7 G06K		
Documentation searched other than minimum documentation to the extent that such documents are included in the fields searched		
Electronic data base consulted during the international search (name of data base and, where practical, search terms used) INSPEC, WPI Data, IBM-TDB, PAJ, EPO-Internal, COMPENDEX		
C. DOCUMENTS CONSIDERED TO BE RELEVANT		
Category *	Citation of document, with indication, where appropriate, of the relevant passages	Relevant to claim No.
Y	GB 2 313 441 A (MOTOROLA ISRAEL LTD) 26 November 1997 (1997-11-26) abstract	1-10
Y	PATENT ABSTRACTS OF JAPAN vol. 1998, no. 14, 31 December 1998 (1998-12-31) & JP 10 262071 A (FUJI PHOTO FILM CO LTD), 29 September 1998 (1998-09-29) abstract	1-10
<p align="center">--- -/--</p>		
<input checked="" type="checkbox"/> Further documents are listed in the continuation of box C. <input checked="" type="checkbox"/> Patent family members are listed in annex.		
* Special categories of cited documents :		
"A" document defining the general state of the art which is not considered to be of particular relevance "E" earlier document but published on or after the international filing date "L" document which may throw doubts on priority claim(s) or which is cited to establish the publication date of another citation or other special reason (as specified) "O" document referring to an oral disclosure, use, exhibition or other means "P" document published prior to the international filing date but later than the priority date claimed "T" later document published after the international filing date or priority date and not in conflict with the application but cited to understand the principle or theory underlying the invention "X" document of particular relevance; the claimed invention cannot be considered novel or cannot be considered to involve an inventive step when the document is taken alone "Y" document of particular relevance; the claimed invention cannot be considered to involve an inventive step when the document is combined with one or more other such documents, such combination being obvious to a person skilled in the art. "&" document member of the same patent family		
Date of the actual completion of the international search 10 July 2000		Date of mailing of the international search report 20/07/2000
Name and mailing address of the ISA European Patent Office, P.B. 5618 Patentlaan 2 NL - 2280 HV Rijswijk Tel. (+31-70) 340-2040, Tx. 31 651 epo nl, Fax: (+31-70) 340-3016		Authorized officer Granger, B

Form PCT/ISA/210 (second sheet) (July 1992)

INTERNATIONAL SEARCH REPORT

International Application No
PCT/US 99/22709

C.(Continuation) DOCUMENTS CONSIDERED TO BE RELEVANT		
Category	Citation of document, with indication, where appropriate, of the relevant passages	Relevant to claim No.
P, X	<p>SLUIJS F ET AL: "An on-chip USB-powered three-phase up/down DC/DC converter in a standard 3.3 V CMOS process" 2000 IEEE INTERNATIONAL SOLID-STATE CIRCUITS CONFERENCE. DIGEST OF TECHNICAL PAPERS (CAT. NO.00CH37056), 2000 IEEE INTERNATIONAL SOLID-STATE CIRCUITS CONFERENCE. DIGEST OF TECHNICAL PAPERS, SAN FRANCISCO, CA, USA, 7-9 FEB. 2000, pages 440-441, XP000923437 2000, Piscataway, NJ, USA, IEEE, USA ISBN: 0-7803-5853-8 the whole document</p>	1-10
P, X	<p>PATENT ABSTRACTS OF JAPAN vol. 1999, no. 14, 22 December 1999 (1999-12-22) & JP 11 252489 A (MINOLTA CO LTD), 17 September 1999 (1999-09-17) abstract</p>	1-10

Form PCT/ISA/210 (continuation of second sheet) (July 1992)

INTERNATIONAL SEARCH REPORT

Information on patent family members

International Application No

PCT/US 99/22709

Patent document cited in search report	Publication date	Patent family member(s)	Publication date
GB 2313441 A	26-11-1997	NONE	
JP 10262071 A	29-09-1998	NONE	
JP 11252489 A	17-09-1999	NONE	

Form PCT/ISA/210 (patent family annex) (July 1992)

FISI00001115



Europäisches Patentamt
 European Patent Office
 Office européen des brevets



(11) EP 1 198 049 A1

(12) EUROPEAN PATENT APPLICATION

(43) Date of publication:
 17.04.2002 Bulletin 2002/16

(51) Int Cl.7: H02J 7/00

(21) Application number: 00122142.3

(22) Date of filing: 12.10.2000

(84) Designated Contracting States:
 AT BE CH CY DE DK ES FI FR GB GR IE IT LI LU
 MC NL PT SE
 Designated Extension States:
 AL LT LV MK RO SI

(74) Representative: Körber, Martin, Dipl.-Phys. et al
 Mitscherlich & Partner
 Patentanwälte
 Sonnenstrasse 33
 80331 München (DE)

(71) Applicant: Sony International (Europe) GmbH
 10785 Berlin (DE)

Remarks:
 The application is published incomplete as filed
 (Article 93 (2) EPC). Claim number 7 is missing.

(72) Inventor: Tong, Zhao, c/o Digital Telecom. Europe
 85609 Aschheim (DE)

(54) Charging circuit for charging a mobile terminal through an USB interface

(57) The present invention relates to a charging circuit (1) for charging a mobile terminal (2) of a wireless telecommunication system through a USB interface of a computer (3), with first connection means (4) for connection with the USB interface of a computer (3), second connection means (5) for connection with a mobile terminal (2) to be charged, and adaptation means (6; 7; 8)

for adapting power received from the USB interface to the power requirements of a mobile terminal to be charged. The present invention further relates to a mobile terminal (2) adapted to be connected and charged by such a charging circuit (1). The present invention enables charging of a mobile terminal through a USB interface of a computer in a simple and flexible way.

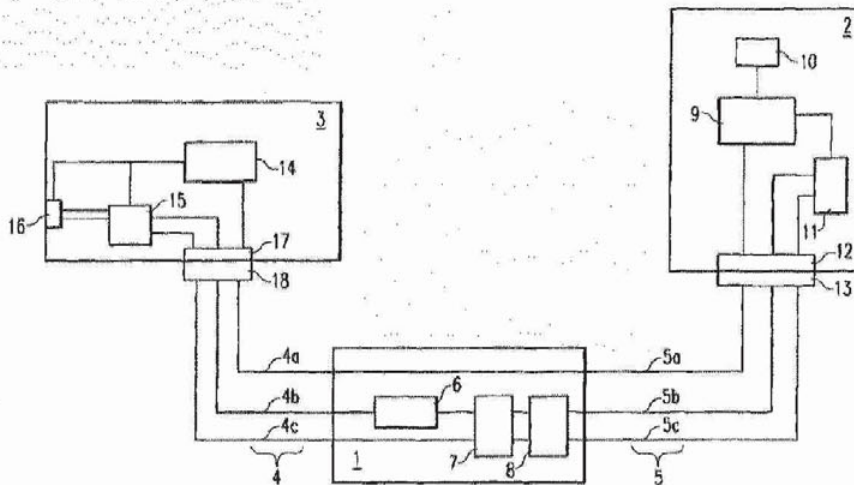

Fig. 1

Printed by Jouve, 75001 PARIS (FR)

EP 1 198 049 A1

FISI00001116

Description

[0001] The present invention relates to a charging circuit for charging a mobile terminal of a wireless telecommunication system through a USB interface of a computer and to a mobile terminal for a wireless telecommunication system adapted to be connected to and charged by such a charging circuit.

[0002] Charging circuits for charging batteries or accumulators of mobile terminals are known in the art. For example, US 5,870,615 discloses a specially designed PCMCIA card comprising a charging circuit for charging the battery of a cellular phone and an adapter cable having a battery characteristic encoder integrated at one end. However, a PCMCIA card can only be used with portable computers, such as laptops, notebooks or the like so that the proposed way of charging a mobile terminal is limited to these applications.

[0003] The object of the present invention is therefore to propose a charging circuit for charging a mobile terminal of a wireless telecommunication system and a mobile terminal adapted to be connected to and charged by such a charging circuit, which can be used with different kinds of computers in a simple and effective way.

[0004] The above object is achieved by a charging circuit for charging a mobile terminal of a wireless telecommunication system through a USB interface of a computer, with first connection means for a connection with the USB interface of a computer, second connection means for a connection with a mobile terminal to be charged, and adaptation means for adapting power received from said USB interface to the power requirements of a mobile terminal to be charged.

[0005] Most of the available computers, such as PCs, laptops, notebooks and the like, are equipped with a USB interface (universal serial bus interface) for connection with other devices. The USB interface is realised with a standardised USB port in the computers, to which a corresponding USB plug from a USB data cable is connected. The USB interface comprises four lines, namely two data lines, one power line and one ground line. The charging circuit according to the present invention therefore presents a very flexible and universally usable way of charging a mobile terminal of a wireless telecommunication system. Particularly, the charging circuit according to the present invention has the advantage that a mobile terminal for a wireless telecommunication system can be charged at any place of the world with only a single charging circuit. Normal charging cables for mobile terminals are only adapted to the specific power supply system used in the respective country. A USB interface, however, is an internationally used and standardised way of connecting devices to computers.

[0006] Advantageously, the adaptation means of the charging circuit according to the present invention comprises a current limiter to limit the current received from the USB interface to a maximum charging current of the mobile terminal. The current limiter is advantageous in

respect of protection against TDMA bursts and other kinds of bursts used in the mobile terminal for the wireless transmission of data. Further advantageously, the adaptation means comprises a short circuit protection means for protecting the mobile terminal and/or the computer against short circuits. Further advantageously, the adaptation means comprises a voltage regulator for regulating the voltage received from the USB interface to the charging requirements of the mobile terminal. The voltage regulator is particularly advantageous for stabilising the voltage supplied to the mobile terminal.

[0007] It has to be understood, that in the present application, the expression charging a mobile terminal means charging of the battery or the accumulator of a mobile terminal.

[0008] Further advantageously, the first connection means is a USB cable for connection with a USB port of the computer and the second connection means is a mobile terminal cable for connection with a corresponding data input/output and charge port of the mobile terminal. Here, the charging circuit according to the present invention is an independent device with respective cables for the connection with the computer and the mobile terminal. Alternatively, the charging circuit according to the present invention can be built in the mobile terminal or the computer to that an integrated solution is realised. In further alternative solutions, the charging circuit according to the present invention could have a USB port as the first connection means and/or a respective mobile terminal cable port as the second connection means. Here, standardised cables and plugs could be used as the cable connections between the computer as a charging circuit and the charging circuit and the mobile terminal. A further advantage of this solution is that the charging circuit according to the present invention could be used with different kinds of mobile terminals having different kinds of data input/output and charge ports for the connection with the charging circuit.

[0009] Further, the charging circuit according to the present invention advantageously comprises a data line for transmitting power supply status information from the computer to the mobile terminal. The charging circuit according to the present invention as described above does not necessarily need to enable a data transfer between the computer and the mobile terminal and the conversion and adaptation of power received from the computer to the power requirements for charging the mobile terminal is generally sufficient for the purpose of the present invention. However, the communication of data between the computer and the mobile terminal is necessary for embodiments in which the charging of the mobile terminal is controlled in dependence of the status of the power supply of the computer.

[0010] The above object is further achieved by a mobile terminal for a wireless telecommunication system according to claim 8, which comprises a battery providing power supply, connection means adapted to be con-

nected to a charging circuit of the above described kind, and control means for controlling the charging of the battery from a USB interface of a computer.

[0011] The battery of the mobile terminal according to the present invention which is to be charged by the charging circuit as above described, is for example part of a removable battery pack or accumulator of the mobile terminal. The connection means of the mobile terminal adapted to be connected to the inventive charging circuit is for example a data input/output and charge port of the mobile terminal, which serves also for other purposes, such as connecting a hands free kit or the like. The control means for controlling the charging of the battery is for example the central control microchip or microprocessor of the mobile terminal responsible for controlling the common functionalities. The wireless telecommunication system, in which the mobile terminal according to the present invention operates, can for example be the GSM and/or the UMTS and/or any other wireless telecommunication system.

[0012] Advantageously, the control means of the mobile terminal detects the charge level of the battery and controls the charging of the battery from a USB interface through a connected charging circuit on the basis of the detected charge level. Hereby, the control means advantageously charges the battery if the detected charge level is below a pre-set value. This value can for example be about 5% of the entire battery capacity. In this example of the mobile terminal according to the present invention, charging of the battery is performed only on the basis of the charge level of the battery and no further other information is used. Thus, the charging circuit can be reduced to the pure power conversion and adaptation function in order to deliver the specific voltage and current to the mobile terminal. The charging process is only controlled by the mobile terminal itself and not by the computer or the user. Alternatively, the charging circuit can, additionally to the power lines, comprise data lines for communicating data between the computer and the mobile terminal. In this way, the mobile terminal can be charged via the USB interface, while at the same time the data communication, for example for downloading or uploading data from and to the computer, can be performed.

[0013] In a further alternative example of the mobile terminal according to the present invention, the control means is adapted to receive a power supply status information of a computer through a connected charging circuit and controls the charging of the battery from a USB interface of the computer through the connected charging circuit on the basis of the received power supply status information. Here, charging of the battery of the mobile terminal is performed only if the received power supply status information indicates that the power supply status of the computer allows charging of the battery of the mobile terminal. Advantageously, the control means charges the battery if the received power supply status information indicates that the computer is con-

nected to and powered by an external power supply. In this case, the battery of the mobile terminal is thus charged through the external power supply of the computer in any case in which the battery of the mobile terminal is not fully charged. Further advantageously, the control means is adapted to detect the charge level of the battery and charges the battery if the received power supply status information indicates that the computer is powered by an internal power supply and that the detected charge level is below a pre-set value. The pre-set value is advantageously about 5% of the entire battery capacity. Here, in order to save power for the computer, the battery is only charged if its charge level is so low that there is a risk that the mobile terminal cannot be further operated due to a lack of power. The last case is particularly applicable to mobile computers, such as laptops, notebooks and the like, which have an internal power supply in form of a detachable battery pack, an accumulator or the like. Here it is very important that the power resources of the computer as well as the mobile terminal are carefully controlled to ensure proper operation.

[0014] It is to be noted that in the example of the mobile terminal controlling the charging of its battery on the basis of a power supply status information received from the computer, the computer needs an appropriate driver software which detects the power status of the computer and transmits a corresponding information via the USB interface to the mobile terminal. Hereby, the data line of the charging circuit according to the present invention used for the transmission of the power supply status information between the computer and the mobile terminal can also be used for the communication of download/upload data and the like.

[0015] In the following description, the present invention is explained in more detail in relation to the enclosed only Figure 1, which shows a schematic block diagram of a charging circuit and a mobile terminal according to the present invention being connected to a computer.

[0016] Particularly, Fig. 1 shows a block diagram of a charging circuit 1 according to the present invention for charging a mobile terminal 2 of a wireless telecommunication system through a USB interface of a computer 3. Fig. 1 thereby shows an embodiment in which the charging circuit 1 comprises a connection cable 4 connected to the computer 3 and a connection cable 5 connected to the mobile terminal 2. In another embodiment of the charging circuit 1 according to the present invention, the connection cables 4 and 5 can be separate devices to be detachably connected to the charging circuit 1.

[0017] The connection cable 5 connecting the charging circuit 1 and the computer 3 is a USB data cable (universal serial bus data cable), which comprises at least one data line 4a, one power line 4b and one ground line 4c. The power line 4b is considered for powering USB devices and delivers usually $5V \pm 5\%$ voltage and 500mA/100mA current so that the charging specifica-

tions of most mobile terminals for wireless telecommunication systems, such as the UMTS and/or the GSM system, are met.

[0018] The charging circuit 1 comprises adaptation means for adapting the power received from the USB interface of the computer 3 to the power requirements of the mobile terminal 2 to be charged. The adaptation means hereby comprise a current limiter 6 to limit the current in the power line 4b to the maximum charging current of the mobile terminal 2. The adaptation means further comprise a short circuit protection means 7 for protecting the mobile terminal 2 and/or the computer 3 against short circuits. The voltage received from the USB interface is regulated by a voltage regulator 8 to meet the charging requirements of the mobile terminal 2.

[0019] The connection cable 5 between the charging circuit 1 and the mobile terminal 2 comprises at least one data line 5a which is connected to the data line 4a of the connection cable 4 so that data are communicated between the computer 3 and the mobile terminal 2 via the data line 4a and the data line 5a. The connection cable 5 comprises a connector plug 13 for connection with an input/output and charge board 12 of the mobile terminal 2. Hereby, the power line 5b and the ground line 5c are connected to a battery 11 of the mobile terminal 2. The battery 11 can be an integral battery or a removable battery/accumulator. Further, the data line 5a is herewith connected to a control means 9 of the mobile terminal 2, which is connected to a memory means 10 for storing data and/or software application programs. The control means 9 controls the charging of the battery 11 from the USB interface of the computer 3 through the charging circuit 1.

[0020] The USB interface of the computer 3 is realised in a USB port 17, to which a USB plug 18 of the connection cable 4 of the charging circuit 1 is connected. Hereby, the power line 4b and the ground line 4c are connected to either an internal battery/accumulator 15 of the computer means 3 or to an external power supply socket 16, to which an external power source for the computer 3 can be connected. Thus, the battery 11 of the mobile terminal 2 is either charged from the internal battery/accumulator 15 of the computer 3 or an external power supply connected to the external power supply socket 16 of the computer 3.

[0021] The control means 9 of the mobile terminal 2 can control the charging process of the battery 11 in two ways. The first way is that the charging process is exclusively controlled by the control means 9, which, after detection that the mobile terminal 2 is connected to a USB interface of a computer 3 and that the battery level of the battery 11 is below a pre-set value starts to charge the battery 11. The charging circuit 1 will then deliver the specific voltage and current through the power lines 4b, 5b and the ground lines 4c, 5c to the battery 11. The current limiter and the voltage regulator are thereby set to the specific power requirements of the battery 11. In

case that the charging circuit 1 is to be used with different kinds of mobile terminals 2, the necessary current and voltage values could for example be externally set by a user through a corresponding input means to the charging circuit 1. The power control software for controlling the charging of the battery is implemented in the memory 10 of the mobile terminal 2 and used by the control means 9 for detecting if the mobile terminal 2 is connected to an USB interface of a computer 3, to detect the charge level of the battery 11 and to control the charging process correspondingly. The pre-set value, from which charging of the battery 11 starts, can for example be 5% of the entire battery capacity. The control means 9 is for example a microchip or a microprocessor of the mobile terminal 2 which also controls other important functions of the mobile terminal.

[0022] In a second way of controlling the charging process of the battery 11 of the mobile terminal 2, the control means 9 receives a power supply status information of the computer 3 through the data lines 4a and 5a and controls the charging of the battery on the basis of the received power supply information. The power supply status information received from the computer 3 indicates if the computer 3 is connected to an internal battery/accumulator 15 or to an external power supply via the external power supply socket 16. The power supply status information is thereby detected in the computer 3 by a control means 14 and supplied via the data line 4a and the data line 5a to the control means 9 of the mobile terminal 2. In case that the received power supply status information indicates that the computer 3 is connected to an external power supply, the control means 9 charges the battery 11 independent of its charge level. If, on the other hand, the power control status information indicates that the computer 3 is only connected to and powered by an internal power supply, such as the battery/accumulator 15, the control means 9 detects the charge level of the battery 11 and only starts charging of the battery 11 via the charging circuit 1 if the charge level is below a pre-set value, as for example 5% of the entire battery capacity. Here, the control means 14 of the computer 3 may for example use the Microsoft Power Manager and a further special software application, as for example a USB data cable driver, to detect the power supply status of the computer 3 and supply a corresponding power status information to a connected mobile terminal 2. Each time a USB cable, as for example a connection cable 4 of the charging circuit 1 is connected to the USB port 17 of the computer 3, the USB data cable driver will start automatically and activate the Microsoft Power Manager to get the status of the power supply of the computer 3. After the USB cable is disconnected, the USB data cable driver will be automatically closed. Thus, no further special applications or software is needed on the computer 3 and the charging circuit 1 can be used as a so-called plug and play device. Further, the USB data cable driver only runs when a USB data cable is connected to the USB port

17, instead running the whole time in the background. Hereby, computer resources are saved. The USB data cable driver could also protect itself at queuing and sending power supply information to a mobile terminal 2 by other drivers of other manufacturers.

[0023] The present invention is particularly advantageous, since the battery 11 of the mobile terminal 2 can be charged while the user works on the basis of the data connection between the mobile terminal 2 and the computer 3, for example while down- or uploading data or the like.

Claims

1. Charging circuit (1) for charging a mobile terminal (2) of a wireless telecommunication system through a USB interface of a computer (3), with first connection means (4) for connection with the USB interface of a computer (3), second connection means (5) for connection with a mobile terminal (2) to be charged, and adaptation means (6, 7, 8) for adapting power received from said USB interface to the power requirements of a mobile terminal to be charged.

2. Charging circuit (1) according to claim 1, **characterized in,** that said adaptation means comprises a current limiter (6) to limit the current received from the USB interface to a maximum charging current of the mobile terminal (2).

3. Charging circuit (1) according to claim 1 or 2, **characterized in,** that said adaptation means comprises a short circuit protection means (7) for protecting the mobile terminal (2) and/or the computer (3) against short circuits.

4. Charging circuit (1) according to claim 1, 2 or 3, **characterized in,** that said adaptation means comprises a voltage regulator (8) for regulating the voltage received from the USB interface to the charging requirements of the mobile terminal (2).

5. Charging circuit (1) according to one of the claims 1 to 4, **characterized in,** that said first connection means (4) is a USB cable for connection with a USB port (17) of the computer and said second connection means (5) is a mobile terminal cable for connection with a corresponding data input/output and charge port (12) of the mobile terminal (2).

6. Charging circuit (1) according to one of the claims

1 to 5,

characterized by

a data line (4a, 5a) for transmitting power supply status information from the computer (3) to the mobile terminal (2).

8. Mobile terminal (2) for a wireless telecommunication system, comprising

a battery (11) providing power supply, connection means (12) adapted to be connected to a charging circuit (1) according to one of the claims 1 to 6, and control means (9) for controlling the charging of the battery (11) from a USB interface of a computer (3).

9. Mobile terminal (2) according to claim 8, **characterized in,** that the control means (9) detects the charge level of the battery (11) and controls the charging of the battery (11) from a USB interface through a connected charging circuit (1) on the basis of the detected charge level.

10. Mobile terminal (2) according to claim 9, **characterized in,** that the control means (9) charges said battery (11) if the detected charge level is below a preset value.

11. Mobile terminal (2) according to claim 10, **characterized in,** that the control means (9) charges said battery if the detected charge level is below about 5% of the entire battery capacity.

12. Mobile terminal (2) according to claim 8, **characterized in,** that the control means (9) is adapted to receive a power supply status information of a computer (3) through a connected charging circuit (1) and controls the charging of the battery from a USB interface of the computer (3) through the connected charging circuit (1) on the basis of the received power supply status information.

13. Mobile terminal (2) according to claim 12, **characterized in,** that the control means (9) charges said battery if the received power supply status information indicates that the computer (3) is connected to an external power supply.

14. Mobile terminal (2) according to claim 12 or 13, **characterized in,** that the control means (9) is adapted to detect the charge level of said battery and charges said battery if the received power supply status information

indicates that the computer (3) is powered by an internal power supply and that the detected charge level is below a preset value.

15. Mobile terminal (2) according to claim 14, characterized in, that the preset value is about 5% of the entire battery capacity.

5

10

15

20

25

30

35

40

45

50

55

6

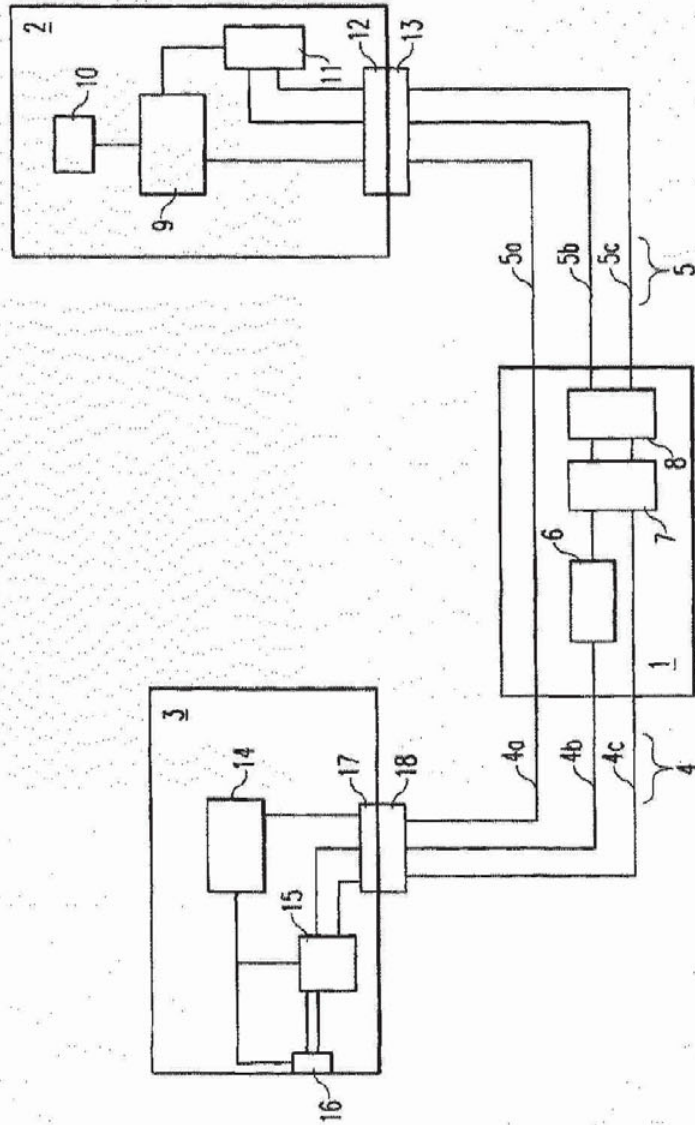

Fig. 1



European Patent Office

EUROPEAN SEARCH REPORT

Application Number
EP 00 12 2142

DOCUMENTS CONSIDERED TO BE RELEVANT			
Category	Citation of document with indication, where appropriate, of relevant passages	Relevant to claim	CLASSIFICATION OF THE APPLICATION (Int.Cl.7)
X	DE 200 04 691 U (YANG WEN CHIN) 29 June 2000 (2000-06-29) * page 1, paragraph 3 - paragraph 4 *	1,3-5, 8-10	H02J7/00
Y	* page 4, line 28 - line 30 *	6,12	
Y	PATENT ABSTRACTS OF JAPAN vol. 1998, no. 12, 31 October 1998 (1998-10-31) & JP 10 201127 A (NEC CORP), 31 July 1998 (1998-07-31) * abstract *	6,12	
A	PATENT ABSTRACTS OF JAPAN vol. 2000, no. 09, 13 October 2000 (2000-10-13) & JP 2000 165513 A (KYOCERA CORP), 16 June 2000 (2000-06-16) * abstract *	6,12-14	
A	PATENT ABSTRACTS OF JAPAN vol. 2000, no. 04, 31 August 2000 (2000-08-31) & JP 2000 020176 A (MINOLTA CO LTD), 21 January 2000 (2000-01-21) * abstract *	12-14	TECHNICAL FIELDS SEARCHED (Int.Cl.7) H02J H01M H04B H04M
A	PATENT ABSTRACTS OF JAPAN vol. 2000, no. 08, 6 October 2000 (2000-10-06) & JP 2000 139032 A (KYOCERA CORP), 16 May 2000 (2000-05-16) * abstract *	1-15	

The present search report has been drawn up for all claims			
Place of search		Date of completion of the search	Examiner
THE HAGUE		13 March 2001	Moyle, J
CATEGORY OF CITED DOCUMENTS		T : theory or principle underlying the invention E : earlier patent document, but published on, or after the filing date D : document cited in the application L : document cited for other reasons & : member of the same patent family, corresponding document	
X : particularly relevant if taken alone Y : particularly relevant if combined with another document of the same category A : technological background O : non-written disclosure □ : intermediate document			

EPO FORM 1503 (12.02.99) (P0003)

**ANNEX TO THE EUROPEAN SEARCH REPORT
ON EUROPEAN PATENT APPLICATION NO.**

EP 00 12 2142

This annex lists the patent family members relating to the patent documents cited in the above-mentioned European search report. The members are as contained in the European Patent Office EDP file on The European Patent Office is in no way liable for these particulars which are merely given for the purpose of information.

13-03-2001

Patent document cited in search report	Publication date	Patent family member(s)	Publication date
DE 20004691 U	29-06-2000	NONE	
JP 10201127 A	31-07-1998	JP 3085226 B	04-09-2000
JP 2000165513 A	16-06-2000	NONE	
JP 2000020176 A	21-01-2000	NONE	
JP 2000139032 A	16-05-2000	NONE	

EP FORM 1/1948

For more details about this annex : see Official Journal of the European Patent Office, No. 12/82

Electronic Patent Application Fee Transmittal				
Application Number:				
Filing Date:				
Title of Invention:		System and Method for Charging a Battery in a Mobile Device		
First Named Inventor/Applicant Name:		Daniel M. Fischer		
Filer:		J. Robert Brown/Karen Harris		
Attorney Docket Number:		10254-US-CNT4 4214-01509		
Filed as Large Entity				
Utility under 35 USC 111(a) Filing Fees				
Description	Fee Code	Quantity	Amount	Sub-Total in USD(\$)
Basic Filing:				
Utility application filing	1011	1	330	330
Utility Search Fee	1111	1	540	540
Utility Examination Fee	1311	1	220	220
Pages:				
Claims:				
Independent claims in excess of 3	1201	1	220	220
Miscellaneous-Filing:				
Petition:				

FISI00001125

Description	Fee Code	Quantity	Amount	Sub-Total in USD(\$)
Patent-Appeals-and-Interference:				
Post-Allowance-and-Post-Issuance:				
Extension-of-Time:				
Miscellaneous:				
Total in USD (\$)				1310

Electronic Acknowledgement Receipt	
EFS ID:	7101776
Application Number:	12714204
International Application Number:	
Confirmation Number:	6230
Title of Invention:	System and Method for Charging a Battery in a Mobile Device
First Named Inventor/Applicant Name:	Daniel M. Fischer
Customer Number:	30652
Filer:	J. Robert Brown/Karen Harris
Filer Authorized By:	J. Robert Brown
Attorney Docket Number:	10254-US-CNT4 4214-01509
Receipt Date:	26-FEB-2010
Filing Date:	
Time Stamp:	18:14:20
Application Type:	Utility under 35 USC 111(a)

Payment information:

Submitted with Payment	yes
Payment Type	Deposit Account
Payment was successfully received in RAM	\$1310
RAM confirmation Number	5472
Deposit Account	501515
Authorized User	
<p>The Director of the USPTO is hereby authorized to charge indicated fees and credit any overpayment as follows:</p> <ul style="list-style-type: none"> Charge any Additional Fees required under 37 C.F.R. Section 1.16 (National application filing, search, and examination fees) Charge any Additional Fees required under 37 C.F.R. Section 1.17 (Patent application and reexamination processing fees) 	

FISI00001127

Charge any Additional Fees required under 37 C.F.R. Section 1.19 (Document supply fees)
 Charge any Additional Fees required under 37 C.F.R. Section 1.20 (Post Issuance fees)
 Charge any Additional Fees required under 37 C.F.R. Section 1.21 (Miscellaneous fees and charges)

File Listing:

Document Number	Document Description	File Name	File Size(Bytes)/ Message Digest	Multi Part /.zip	Pages (if appl.)
1		4214-01509_Specification.pdf	746959 51f05042401bee61e2db2ac694937a5e899219/3	yes	29
Multipart Description/PDF files in .zip description					
	Document Description		Start		End
	Specification		1		23
	Claims		24		28
	Abstract		29		29
Warnings:					
Information:					
2	Drawings-only black and white line drawings	4214-01509_Drawings.pdf	74324 5b53cee9393590e5d5e11a8b0274607de884371	no	4
Warnings:					
Information:					
3	Oath or Declaration filed	4214-01509_Declaration.pdf	232778 9402cc13f115335f4b0192b16401748a97fbb78d	no	8
Warnings:					
Information:					
4	Application Data Sheet	4214-01509_ApplicationDataSheet.pdf	1554444 3a298b74c17702a739b70a368f561bedf0280	no	6
Warnings:					
Information:					
5	Information Disclosure Statement (IDS) Filed (SB/08)	4214-01509_InformationDisclosureStatement.pdf	1017396 497fec1cfa06189b4d0b61b90b2c9c02f66c07a	no	7
Warnings:					
Information:					
6	Foreign Reference	EP684680.pdf	46100 d8a03474d1518b8bf5c903c0c0194ebf83917a	no	7
Warnings:					

FISI00001128

Information:					
7	Foreign Reference	WO200101330.pdf	802574 185b2119f8bccc34e7d4b60708d50ecc099 99dc	no	22
Warnings:					
Information:					
8	Foreign Reference	EP1198049.pdf	160110 cbf5e2d75eb7ec36711e66e04e025e11d3 898305	no	9
Warnings:					
Information:					
9	NPL Documents	ElectricDoublelayerCapacitors. PDF	1323773 c6e129f0c9d531e325943037785101d3 0077	no	40
Warnings:					
Information:					
10	NPL Documents	Supercapacitor.PDF	2441473 95717d6e9d500a05c298f0bd3237dca13 23b09	no	47
Warnings:					
Information:					
11	NPL Documents	ChargingBigSupercaps.PDF	66023 c121a072d07d39c64a21d63931581d736 27c77	no	1
Warnings:					
Information:					
12	Fee Worksheet (PTO-875)	fee-info.pdf	36213 27bc514e828312111c3c9962e097e06740f 6210f	no	2
Warnings:					
Information:					
Total Files Size (in bytes):				8502367	

This Acknowledgement Receipt evidences receipt on the noted date by the USPTO of the indicated documents, characterized by the applicant, and including page counts, where applicable. It serves as evidence of receipt similar to a Post Card, as described in MPEP 503.

New Applications Under 35 U.S.C. 111

If a new application is being filed and the application includes the necessary components for a filing date (see 37 CFR 1.53(b)-(d) and MPEP 506), a Filing Receipt (37 CFR 1.54) will be issued in due course and the date shown on this Acknowledgement Receipt will establish the filing date of the application.

National Stage of an International Application under 35 U.S.C. 371

If a timely submission to enter the national stage of an international application is compliant with the conditions of 35 U.S.C. 371 and other applicable requirements a Form PCT/DO/EO/903 indicating acceptance of the application as a national stage submission under 35 U.S.C. 371 will be issued in addition to the Filing Receipt, in due course.

New International Application Filed with the USPTO as a Receiving Office

If a new international application is being filed and the international application includes the necessary components for an international filing date (see PCT Article 11 and MPEP 1810), a Notification of the International Application Number and of the International Filing Date (Form PCT/RO/105) will be issued in due course, subject to prescriptions concerning national security, and the date shown on this Acknowledgement Receipt will establish the international filing date of the application.

System and Method for Charging a Battery in a Mobile Device

CROSS-REFERENCE TO RELATED APPLICATIONS

[0001] This is a continuation application of U.S. Patent Application No. 12/268,297 filed November 10, 2008 by Daniel M. Fischer, et al. and entitled "System and Method for Charging a Battery in a Mobile Device", which claims priority from U.S. Patent No. 7,453,233 issued on November 18, 2008 by Daniel M. Fischer, et al. and entitled "Multifunction Charger System and Method", which claims priority from U.S. Patent No. 7,239,111 issued on July 3, 2007, by Daniel M. Fischer, et al. and entitled "Universal Serial Bus Adapter for a Mobile Device", which claims priority from U.S. Patent No. 6,936,936 issued on August 30, 2005, by Daniel M. Fischer, et al. and entitled "Multifunctional Charger System and Method", which claims priority from U.S. Provisional Application No. 60/273,021 filed March 1, 2001, by Daniel M. Fischer, et al. and entitled "System and Method for Adapting a USB to Provide Power for Charging a Mobile Device" and U.S. Provisional Application No. 60/330,486 filed October 23, 2001, by Daniel M. Fischer, et al. and entitled "Multifunctional Charger System and Method" and all incorporated herein by reference for all purposes.

BACKGROUND

[0002] This invention relates generally to power adapters. More particularly, the invention relates to power adapters for use with mobile devices.

[0003] Providing an external source of power to a mobile device, such as a personal digital assistants ("PDA"), mobile communication device, cellular phone, wireless two-way e-mail communication device, and others, requires design considerations with

respect to both the mobile device and the power source. With regard to the mobile device, most mobile devices provide a distinct power interface for receiving power from a power source, for instance to recharge a battery, and a separate data interface for communicating. For example, many mobile devices presently use USB (Universal Serial Bus) interfaces for communicating and use a separate power interface, such as a barrel connector, for receiving power.

[0004] It is desirable, however, to have a combined power and data interface. The mobile devices that do have combined power and data interfaces typically use non-standard and sometimes proprietary interfaces. Consequently, combined interfaces for a particular manufacturer's mobile device may not be compatible with combined interfaces for mobile devices provided by other manufacturers.

[0005] Although the USB interface can be used as a power interface, the USB is typically not used for that purpose by mobile devices. In accordance with the USB specification, typical USB power source devices, such as hubs and hosts, require that a USB device participate in a host-initiated process called enumeration in order to be compliant with the current USB specification in drawing power from the USB interface. Although a mobile device could be adapted to participate in enumeration when drawing power over the USB interface, it would be preferable in many situations, such as when a host would not be available, as often happens during normal use of a mobile device, to be able to utilize alternate power sources such as conventional AC outlets and DC car sockets that are not capable of participating in enumeration to supply power to the mobile device via a USB interface.

SUMMARY

[0006] An adapter for providing a source of power to a mobile device through an industry standard port is provided. In accordance with one aspect of the invention, the adapter comprises a plug unit, a power converter, a primary connector, and an identification subsystem. The plug unit is operative to couple the adapter to a power socket and operative to receive energy from the power socket. The power converter is electrically coupled to the plug unit and is operable to regulate the received energy from the power socket and to output a power requirement to the mobile device. The primary connector is electrically coupled to the power converter and is operative to couple to the mobile device and to deliver the outputted power requirement to the mobile device. The identification subsystem is electrically coupled to the primary connector and is operative to provide an identification signal.

[0007] In accordance with another aspect, a USB adapter for providing a source of power to a mobile device through a USB port is provided. The USB adapter comprises a plug unit, a power converter, a primary USB connector, and an identification subsystem. The plug unit is operative to couple the USB adapter to a power socket and operative to receive energy from the power socket. The power converter is electrically coupled to the plug unit and is operable to regulate the received energy from the power socket and to output a power requirement to the mobile device. The primary USB connector is electrically coupled to the power converter and is operative to couple to the mobile device and to deliver the outputted power requirement to the mobile device. The identification subsystem is electrically coupled to the primary connector and is operative to provide an identification signal.

[0008] Another aspect provides a USB adapter for providing a source of power to a mobile device through a USB port. The USB adapter comprises a plug unit, a power converter, a primary USB connector, and an auxiliary USB adapter. The plug unit is operative to couple the USB adapter to a power socket and operative to receive energy from the power socket. The power converter is electrically coupled to the plug unit and is operable to regulate the received energy from the power socket and to output a power requirement to the mobile device. The primary USB connector is electrically coupled to the power converter and is operative to couple to the mobile device and to deliver the outputted power requirement to the mobile device. The auxiliary USB connector has data lines that are electrically coupled to the data lines of the primary USB connector.

[0009] Yet another aspect provides a method for providing energy to a mobile device using a USB adapter that comprises a plug unit, a primary USB connector, a power converter electrically coupled between the plug unit and the primary USB connector, and an identification subsystem electrically coupled to the primary USB connector. The method comprising the steps of coupling the USB connector to the mobile device, coupling the plug unit to a power socket, outputting a power requirement to the mobile device via the power converter and the USB connector, and providing an identification signal to the mobile device, via the identification subsystem and the USB connector, that is operative to inform the mobile device that the USB adapter is not limited by the power limits imposed by the USB specification.

[0010] In accordance with another aspect, a powering system for a mobile device having a USB connector is provided. The powering system comprises a power distribution subsystem in the mobile device that is operable to receive energy through

the USB connector and to distribute the energy to at least one component in the mobile device and a USB adapter that is operative to couple to the USB connector. The USB adapter comprises a plug unit for coupling to a power socket and that is operable to receive energy from the power socket, a power converter electrically coupled to the plug unit for regulating the received energy and for providing a power requirement to the power distribution subsystem, and an identification subsystem that is operable to transmit an identification signal that is operative to identify the USB adapter as not being limited by the power limits imposed by the USB specification.

BRIEF DESCRIPTION OF THE DRAWINGS

[0011] In order that the invention identified in the claims may be more clearly understood, preferred embodiments thereof will be described in detail by way of example, with reference to the accompanying drawings, in which:

[0012] Fig. 1 is a schematic diagram of an exemplary mobile device which has an industry standard interface;

[0013] Fig. 2 is a schematic diagram of a first embodiment of a USB adapter that is coupled to an exemplary mobile device;

[0014] Fig. 3 is a flow chart illustrating an exemplary use of a USB adapter with a mobile device; and

[0015] Fig. 4 is a schematic diagram of an additional exemplary embodiment of a USB adapter that is coupled to both an exemplary mobile device and an external battery.

DETAILED DESCRIPTION

Exemplary Mobile Device

[0016] Turning now to the drawing figures, shown in Fig. 1 is a schematic diagram of an exemplary mobile communication device 10 which has an industry standard interface. The mobile communication device 10 is preferably a two-way communication device having at least voice or data communication capabilities. Preferably, the mobile device 10 is also capable of communicating over the Internet, for example, via a radio frequency ("RF") link. Examples of types of devices that could be classified as a mobile device 10 include a data messaging device, a two-way pager, a cellular telephone with data messaging capabilities, a wireless Internet appliance, a data communication device (with or without telephony capabilities), a personal digital assistants ("PDA"), a wireless two-way e-mail communication device, and others.

[0017] The exemplary mobile device 10 comprises a microprocessor 12, a communication subsystem 14, input/output ("I/O") devices 16, an industry standard interface 18 which in this example is a USB port, and a power subsystem 20. The microprocessor 12 controls the overall operation of the mobile device 10. The communication subsystem 14 provides the mobile device 10 with the ability to communicate wirelessly with external devices such as other mobile devices and other computers. The I/O devices 16 provide the mobile device 10 with input/output capabilities for use with a device user. The USB port 18 provides the mobile device 10 with a serial port for linking directly with other computers and/or a means for receiving power from an external power source. The power subsystem 20 provides the mobile device 10 with a local power source.

[0018] The exemplary communication subsystem **14** comprises components such as a receiver **22**, a transmitter **24**, antenna elements **26** and **28**, local oscillators (LOs) **30**, and a processing module such as a digital signal processor (DSP) **32**. The particular design of the communication subsystem **14** and the components used therein can vary. It would be apparent to one of ordinary skill in the art to design an appropriate communication subsystem using conventional methods and components to operate over a communication network **34** based on the parameters necessary to operate over that communication network. For example, a mobile device **10** geographically located in North America may include a communication subsystem **14** designed to operate within the Mobitex™ mobile communication system or DataTAC™ mobile communication system, whereas a mobile device **10** intended for use in Europe may incorporate a General Packet Radio Service (GPRS) communication subsystem **14**.

[0019] Network access requirements will also vary depending upon the type of network **34**. For example, in the Mobitex and DataTAC networks, mobile devices **10** are registered on the network using a unique personal identification number or PIN associated with each device. In GPRS networks however, network access is associated with a subscriber or user of a mobile device **10**. A GPRS device therefore requires a subscriber identity module (not shown), commonly referred to as a SIM card, in order to operate on a GPRS network. Without a SIM card, a GPRS device will not be fully functional. Local or non-network communication functions (if any) may be operable, but the mobile device **10** will be unable to carry out any functions involving communications over the network **34**.

[0020] When required, after the network registration or activation procedures have been completed, a mobile device **10** may send and receive communication signals over the network **34**. Signals received by the receiver antenna **26** through a communication network **34** are input to the receiver **22**, which may perform such common receiver functions as signal amplification, frequency down conversion, filtering, channel selection and the like, and in the exemplary system shown in Fig. 1, analog to digital conversion. Analog to digital conversion of a received signal allows more complex communication functions such as demodulation and decoding to be performed in a DSP **32**. Similarly, signals to be transmitted are processed, including modulation and encoding for example, by the DSP **32** and input to the transmitter **24** for digital to analog conversion, frequency up conversion, filtering, amplification and transmission over the communication network **34** via the transmitter antenna **28**.

[0021] Also, in the exemplary communication subsystem **14**, the DSP **32** processes communication signals and also provides for receiver and transmitter control. For example, the gains applied to communication signals in the receiver **22** and transmitter **24** may be adaptively controlled through automatic gain control algorithms implemented in the DSP **32**.

[0022] In implementing its control function, the microprocessor **12** in the exemplary mobile device **10** executes an operating system. The operating system software used by the microprocessor **12** is preferably stored in a persistent store such as flash memory **36**, or alternatively read only memory (ROM) or similar storage element. The microprocessor **12** may also enable the execution of specific device applications, which preferably are also stored in a persistent store. The operating system, specific device

applications, or parts thereof, may also be temporarily loaded into a volatile store such as in RAM 38.

[0023] A predetermined set of applications which control basic device operations, including at least data and voice communication applications for example, will normally be installed on the mobile device 10 during manufacture. One such application loaded on the mobile device 10 could be a personal information manager (PIM) application. The PIM application preferably is an application for organizing and managing user inputted data items such as e-mail, calendar events, voice mails, appointments, and task items. The PIM data items may be stored in the RAM 38 and/or the flash memory 36.

[0024] The PIM application preferably has the ability to send and receive data items, via the wireless network 34. The PIM data items are preferably seamlessly integrated, synchronized and updated, via the wireless network 34, with corresponding data items stored or associated with a host computer system (not shown) used by the device user. The synchronization of PIM data items is a process by which the PIM data items on the mobile device 10 and the PIM data items on the host computer system can be made to mirror each other.

[0025] There are several possible mechanisms for loading applications onto the mobile device 10. For example, applications may be loaded onto the mobile device 10 through the wireless network 34, an auxiliary I/O subsystem 40, the serial port 18, a short-range communications subsystem 42, such as an infrared ("IR") communication system, or any other suitable subsystem 44. When loading the applications onto the mobile device 10, the device user may install the applications in the RAM 38, the flash

memory 36, or preferably a non-volatile store (not shown) such as ROM for execution by the microprocessor 12. The available application installation mechanisms can increase the utility of the mobile device 10 by providing the device user with a way of upgrading the mobile device 10 with additional and/or enhanced on-device functions, communication-related functions, or both. For example, a secure communication application may be loaded onto the mobile device 10 that allows for electronic commerce functions or other financial transactions to be performed using the mobile device 10.

[0026] The I/O devices 16 may be used to display and/or compose data communication messages. In one mode of operation, a signal received by the mobile device 10, such as a text message or web page download, will be received and processed by the communication subsystem 14, forwarded to the microprocessor 12, which will preferably further process the received signal, and provide the processed signal to one or more of the I/O devices 16 such as a display 46. Alternatively, a received signal such as a voice signal can be provided to a speaker 48, or alternatively to an auxiliary I/O device 40. In another mode of operation a device user may compose a data item such as an e-mail message using a keyboard 50 in cooperation with the display 46 and possibly an auxiliary I/O device 40. Alternatively, a device user may compose a voice message via a microphone 52. The composed data item may then be transmitted over a communication network 34 using the communication subsystem 14.

[0027] A short-range communications subsystem 42 may be provided in the mobile device 10 to allow the mobile device 10 to communicate with other systems or devices, which need not necessarily be similar to device 10. For example, the short-range

communications subsystem 42 may include an infrared device and associated circuitry and components or a Bluetooth™ communication module to allow the device 10 to communicate with similarly-enabled systems and devices.

[0028] The USB port 18 provides the mobile device 10 with a serial port for linking directly with other computers to exchange data and/or to receive power. The USB port 18 also provides the mobile device 10 with a means for receiving power from an external power source. For example, in a personal digital assistant (PDA)-type communication device, the USB port 18 could be used to allow the mobile device 10 to synchronize data with a user's desktop computer (not shown). The USB port 18 could also enable a user to set parameters in the mobile device 10 such as preferences through the use of an external device or software application. In addition the USB port 18 may also be used to provide a means for downloading information or software to the mobile device 10 without using the wireless communication network 34. The USB port 18 can provide a direct and thus reliable and trusted connection that may for example be used to load an encryption key onto the mobile device 10 thereby enabling secure device communication.

[0029] Coupled to the USB port 18 is a USB connector 54. The USB connector 54 is the physical component that couples the USB port to the outside world. In the exemplary mobile device 10, the USB connector 54 is used to transmit and receive data from an external data/power source 56, receive power from the external data/power source 56, direct the transmitted/received data from/to the USB port 18, and direct the received power to the power subsystem 20.

[0030] The exemplary power subsystem **20** comprises a charging and power distribution subsystem **58** and a battery **60**. The charging and power distribution subsystem **58** performs many functions. It may be used to transfer energy to the battery **60** from the external data/power source **56** to charge the battery **60** and also to distribute power to the many power requiring components within the mobile device **10**. The charging subsystem **58** may be capable of determining the presence of a battery **60** and/or a power circuit coupled to the mobile device **10**, such as an AC adapter, USB connection, or car adapter, which alternatively can act as power sources **56** to provide power for the mobile device **10** and to charge the battery **60**. Additionally, the charging subsystem **58** may have the ability to determine if a power source **56** is coupled to the mobile device **10** and, in the absence of such a coupling, cause the mobile device **10** to be powered by the battery **60**.

[0031] The power distributed by the charging and power distribution subsystem **58** may be derived from energy stored in the battery **60** and/or energy received from the external data/power source **56**. When the battery **60** is depleted, the charging and power distribution subsystem **58** transfers energy from the power source **56** to recharge the battery **60**. Optionally, the charging and power distribution subsystem **58** may also transfer energy from the power source **56** to other components in the mobile device **10** to power the mobile device **10** when the battery **60** has been depleted and is recharging. When the data/power source **56** is not connected to the mobile device **10**, power for the device **10** is derived from the battery **60**.

Exemplary USB Adapter

[0032] Fig. 2 is a schematic diagram of a first embodiment of an adapter **100** that can be used to couple the mobile device **10** of fig. 1 to the data/power source **56** of fig. 1. In this example the adapter **100** is a USB adapter **100** that comprises a primary USB connector **102**, a power converter **104**, a plug unit **106**, and an identification subsystem **108**. The power converter is a known element in the art and typically includes at least one of the following components: switching converter, transformer, DC source, voltage regulator, linear regulator and rectifier. In the embodiment shown in fig. 2, the USB adapter **100** is shown coupling a mobile device **10** to one of one or more types of power sockets **110N**, **110D**, **110B**, and **100**. Also shown in fig. 2 is an optional auxiliary USB connector **112** that can be used to couple the mobile device **10** to a data source (not shown) such as a personal computer.

[0033] In the embodiment shown in fig. 2, the primary USB connector **102** is configured to mate with the USB connector **54** of the mobile device **10**. The USB adapter **100** is operable to provide power to the mobile device **10** through the Vbus and Gnd power pins in the USB connectors **54** and **102**. The USB adapter **100** also optionally provides a communication path for data across the D+ and D- data pins in the USB connectors **54** and **102**.

[0034] The plug unit **106** is preferably a conventional plug unit that can be used to couple with a conventional power socket to receive power therefrom. For example, the plug unit **106** can be a two prong or three prong plug of the type used in North America that can couple to a North American AC power socket **110N** that provides 115 VAC. In the embodiment shown in figure 2, the plug unit **106** can accept one or more types of

plug adapters **114N**, **114B**, **114D**, and **114** that are configured to couple to the plug unit **106** and are further configured to directly mate with one or more types of power sockets **110N**, **110D**, **110B**, and **100**. The plug unit **106** can be configured to receive energy from a power socket **110N**, **110D**, **110B**, or **100**, either directly or through the use of a plug adapter, and is operative to transfer the received energy to the power converter **104**.

[0035] The power converter **104** is operative to receive energy from a power socket **110N**, **110D**, **110B**, or **100** and to convert that received energy to a form that can be used by the mobile device **10**. For example, the power converter **104** can be of conventional construction such as a switching power converter that converts 115 VAC to 5 VDC. Also, the power converter **104** could comprise a D.C. regulator circuit that converts a D.C. input to a D.C. output. The power converter **104** could also be adapted to accept a wide range of input energy levels and frequencies. Alternatively, the power converter **104** could be adapted to accept a limited range of input energy levels and frequencies, wherein the plug adapters are operable to convert the possible input energy levels and frequencies to a range that the power converter can accommodate. The power converter **104** provides its energy output to the mobile device **10** via the Vbus and Gnd pins of the primary USB connector **102**.

[0036] Through the use of a variety of different types of plug adapters, the USB adapter **100** can be adapted to receive energy from various types of power sockets **110N**, **110D**, **110B**, or **100**. For example, using the appropriate plug adapter **114**, **114B**, **114D**, and **114N**, the USB adapter **100** can receive energy from a power socket such as

an 115 VAC North American power socket **110N**, or a 12 VDC automobile power socket, or an air power socket, or others.

[0037] For example, in North America, a type "N" power socket is commonly available. The plug adapter **114N** can be releasably attached to the plug unit **106** thereby allowing any North American power socket **114N** to be used as a power source. When traveling to a locale which does not have the North American power socket **114N**, an alternate plug adapter such as adapters **114**, **114B**, or **114D** may be selected by the user, according to the power socket **110D**, **110B**, or **100** available at the locale. The plug adapter **114**, **114B**, or **114D** may then be releasably attached to plug unit **106** in place of the plug adapter **114N**, thereby allowing the USB power adapter **100** to connect to a local power supply via the local power socket. Various other plug adapters are envisioned that can be configured to operate with alternate power sources such as for instance car sockets.

[0038] The power distribution and charging subsystem **58** of the mobile device **10** can selectively use the power provided on the Vbus and Gnd lines of the USB connector **54** to provide power to the mobile device **10**, charge the battery **60**, or both. A more detailed discussion of how the charging function of mobile device **10** can be implemented is described in United States Provisional Application No. 60/273021 filed on March 1st, 2001 and entitled "System and Method for Adapting a USB to Provide Power for Charging a Mobile Device" which has been incorporated herein by reference.

[0039] Typically when a mobile device **10** receives power over the USB from a USB host, it is required to draw power in accordance with the USB specification. The USB

specification specifies a process for transferring energy across the USB called enumeration and limits the electrical current that can flow across the USB.

[0040] The USB adapter **100** contributes to a system wherein a device **10** that follows the USB specification when coupled to a typical USB host via its USB port can be informed that the USB adapter **100** has been coupled to the device **10** and that the device **10** can now draw power without regard to the USB specification and the USB specification imposed limits.

[0041] The identification subsystem **108** provides an identification signal to the mobile device **10** that the power source is not a USB limited source. The identification signal could be the communication of a single voltage on one or more of the USB data lines, different voltages on the two data lines, a series of pulses or voltage level changes, or other types of electrical signals. The identification subsystem **108** that generates the identification signal could have multiple types of configurations. In one embodiment, the identification subsystem **108** comprises a hard-wired connection of a single voltage level to both data lines. In another embodiment, the identification subsystem **108** comprises a USB controller that is operable to communicate an identification signal to the mobile device. Additional embodiments are contemplated. The identification subsystem **108** may optionally be configured to have the capability of electrically connecting or disconnecting the power output from the power converter **104** from the USB connector **102** and/or to connect or disconnect any data inputs from the USB adapter **100** to the USB connector **102**.

[0042] In addition to providing power to the mobile device **10** over the primary USB connector **102**, the USB adapter **100** may optionally be equipped with an auxiliary USB

connector **112** that allows the USB adapter **100** to create a communication path between the mobile device **10** and some other device capable of communicating over the USB such as a personal computer, another mobile device or some other type of device.

[0043] The USB adapter **100** preferably provides a communication path between the D+ and D- pins of the Primary USB connector **102** and the D+ and D- pins of the auxiliary USB connector **112**. In the embodiment shown, the communication path also traverses the identification subsystem **108**. Alternatively, the communication path could bypass the identification subsystem **108**. The USB adapter **100** can thus act as a pass through device for communication between a USB hub or host and a mobile device **10**.

[0044] Optionally, the USB adapter **100** could also transfer energy from the power converter **104** to the auxiliary USB connector **112** thereby providing a device coupled to the auxiliary USB connector **112** with power. In this arrangement, the identification subsystem **108** could also provide an identification signal to the device coupled to the auxiliary USB connector **112** to inform that device that the power source is not a USB limited source.

Exemplary Illustration Of The Use of A USB Adapter With A Mobile Device

[0045] When a USB adapter **100** is connected to a mobile device **10**, the identification subsystem **108** of the USB adapter **100** preferably provides an identification signal to the mobile device **10** to notify the mobile device **10** that the device **10** is connected to a power source that is not subject to the power limits imposed by the USB specification. Preferably, the mobile device **10** is programmed to recognize the identification signal and therefore recognizes that an identification signal has been

transmitted by the USB adapter **100**. After recognizing a valid identification signal, the mobile device **10**, draws power through the USB adapter **100** without waiting for enumeration or charge negotiation.

[0046] The detection of the identification signal may be accomplished using a variety of methods. For example, the microprocessor **12** may detect the identification signal by detecting the presence of an abnormal data line condition at the USB port **18**. The detection may also be accomplished through the use of other device subsystems **44** in the mobile device **10**. The preferred identification signal results from the application of voltage signals greater than 2 volts to both the D+ and D- lines in the USB connector. The preferred method of identification is described below in greater detail with reference to Fig. 3.

[0047] At step **210**, the mobile device **10** detects the presence of a voltage on the Vbus line of the USB connector **54** via the USB port **18**. At step **220**, the mobile device checks the state of the D+ and D- lines of the USB connector. In the example shown in the drawings, the D+ and D- lines are compared to a 2V reference. Also, in this example, the identification subsystem **108** of the USB adapter **100** may have applied a logic high signal, such as +5V reference, to both the D+ and D- lines to identify the attached device as a USB adapter **100**. If the voltages on both the D+ and D- lines of the USB connector are greater than 2 Volts (step **220**), then the mobile device **10** determines that the device connected to the USB connector **54** is not a typical USB host or hub and that a USB adapter **100** has been detected (step **230**). The mobile device **10** can then charge the battery or otherwise use power provided via the Vbus and Gnd lines in the USB connector **54** (step **260**) without waiting for enumeration.

[0048] If, however, after the mobile device **10** detects the presence of a voltage on the Vbus line of the USB connector **54** and determines that the voltages on both the D+ and D- lines of the USB connector are not greater than 2 Volts (step **220**), then the mobile device **10** determines that a USB host or hub has been detected (step **240**). A typical USB host or hub weakly holds its D+ and D- lines at zero volts when it is not connected to another device. The mobile device **10** can then signal the USB host or hub to initiate the enumeration process (step **250**) and can charge the battery or otherwise use power provided via the Vbus and Gnd lines in the USB connector (step **260**) in accordance with the power limits imposed by the USB specification. The enumeration process is typically initiated after the mobile device **10** applies approximately zero volts to the D- line and approximately 5 volts to the D+ line to inform the host of the mobile device's **10** presence and communication speed.

[0049] Therefore, when a USB adapter **100** is coupled to the mobile device **10** and has been identified as a USB adapter **100**, the mobile device **10** can forego the enumeration process and charge negotiation process and immediately draw energy from the USB power adapter **100** at a desired rate, for instance at 5 unit loads, i.e. 500mA. While the mobile device **10** charges its battery using the USB adapter **100**, the mobile device **10** can disable its typical USB functions. If, however, the mobile device **10** detects that a USB host or hub is coupled to the mobile device **10**, the mobile device **10** can apply a voltage to the D+ line to indicate to the USB host or hub that the mobile device **10** is coupled thereto and await enumeration and USB charge negotiation.

[0050] If the USB adapter **100**, is coupled to the mobile device **10**, and the mobile device **10** does not identify the USB adapter **100** through communications with the

identification module **108**, the mobile device **10** may stop drawing energy from the Vbus and Gnd lines of the USB connector **54**. This may occur, for example, if the mobile device **10** is not programmed to identify the USB adapter **100**. The mobile device **10** may mistakenly identify the USB adapter **100** as a typical USB host or hub and await enumeration before drawing substantial energy. To guard against this, the USB adapter **100** can optionally be adapted to function with mobile devices that are not programmed to recognize the USB adapter **100**.

[0051] In that scenario, the USB adapter **100** can be adapted to provide energy to a mobile device by using the knowledge that the mobile device will draw energy from a connected device for a period of time before it stops drawing energy due to lack of enumeration. The USB adapter **100** can optionally provide power for charging a battery **60** in a mobile device by periodically switching the voltages on the Vbus and Gnd lines between on and off states. When the USB adapter **100** is coupled to the mobile device, the identification subsystem **108** can apply an on-voltage (5 V for example) between the Vbus and Gnd lines. The mobile device will draw energy while awaiting enumeration. After a period of time, the identification subsystem **108** can apply an off-voltage (0 volts) between the Vbus and Gnd lines thereby fooling the mobile device into determining that the unidentified USB device has been disconnected from the mobile device. The identification subsystem **108** can then reapply an on-voltage between the Vbus and Gnd lines. The mobile device will draw energy again while awaiting enumeration. This cycle can be repeated to periodically apply energy to the mobile device, for example, to recharge the battery **60** of the mobile device.

Additional Exemplary Embodiments Of USB Adapters

[0052] Shown in fig. 4 is a schematic diagram of an additional exemplary embodiment of a USB adapter **300** that is coupled to a mobile device **10**. The exemplary USB adapter **300** comprises a USB connector **302**, a power converter **304**, a plug unit **306**, and an identification subsystem **308**. The USB connector **302**, plug unit **306**, and identification subsystem **308**, preferably correspond to the USB connector **102**, plug unit **106**, and identification subsystem **108** which were described earlier with respect to the first embodiment. Similar to the first embodiment, the additional embodiment may optionally be equipped with various plug adapters **314N**, **314D**, **314B**, and **314** that preferably are releasably attachable to plug unit **306** so that the appropriate plug adapter **314N**, **314D**, **314B**, or **314** can be selected by a user to allow the USB adapter **300** to couple to and receive energy from an available power socket **310N**, **310D**, **310B**, or **310**. The exemplary USB power converter **300** further comprises a charging subsystem **316** and battery receptacle **318** for coupling the USB adapter **300** to an external battery **320** that may be optionally coupled thereto.

[0053] The battery receptacle **318** provide a location for releasably coupling an external battery **320** thereto so that the external battery can be charged via the USB adapter **300**. This provides the USB adapter **300** with a mechanism for charging, for example, a mobile device's primary or spare battery when the battery has been separated from or is not coupled to the mobile device **10**.

[0054] To accommodate this functionality, the power converter **304** is capable of providing the proper voltage levels for the USB connector **302** and also capable of providing necessary voltage and current levels to drive a battery charging subsystem

316. The power converter **304** is preferably a dual power converter that may be constructed using conventional or non-conventional architectures. With respect to the portion of the power converter **304** that provides energy to the USB connector **302**, that portion is preferably similar in construction and function to the power converter **104** of the first embodiment.

[0055] Preferably, the charging subsystem **316** performs in a substantially similar manner to charging subsystem **58** of the mobile device **10**. But, for efficiency and simplicity of design, certain aspects of the dual power converter **304** and the charging subsystem **316** may be combined, as both are local to the USB adapter **300**.

[0056] Other alternative embodiments of the USB adapter may include various combinations of components described above with respect to the first and additional embodiments. Another embodiment of the USB adapter may include a second or more auxiliary USB connectors. A USB adapter having one or more auxiliary USB connectors may optionally be configured such that one or more of the auxiliary USB connectors may have power from the USB adapter's power converter made available to it so that multiple USB devices may draw power simultaneously. Preferably, a USB adapter having multiple auxiliary USB connectors will be configured such that the data lines in the auxiliary connectors can, on a selective basis, be electrically connected to or disconnected from the data lines in the primary USB connector. This allows a mobile device connected to the primary USB connector to receive energy from the adapter regardless of whether a USB host or hub is connected to an auxiliary USB connector. It is also contemplated that a USB adapter may be embodied in a USB host or hub.

Conclusion

[0057] The embodiments described herein are examples of structures, systems or methods having elements corresponding to the elements of the invention recited in the claims. This written description may enable those skilled in the art to make and use embodiments having alternative elements that likewise correspond to the elements of the invention recited in the claims. The intended scope of the invention thus includes other structures, systems or methods that do not differ from the literal language of the claims, and further includes other structures, systems or methods with insubstantial differences from the literal language of the claims. Although the embodiments have been described with reference to the USB interface, it is contemplated that the invention could be applicable to devices and systems that use other standard interfaces such as the IEEE 1394 interface.

CLAIMS

What is claimed is:

1. A mobile device, the mobile device configurable for use in a wireless telecommunications network, comprising:

a Universal Serial Bus ("USB") interface configured to allow reception of a USB cable;

a charging subsystem, the charging subsystem operably connected to the USB interface V-bus power line;

the charging subsystem operably connectable to a battery, and configured to charge a battery if a battery is operably connected;

the charging system further configured to use power from the V-bus power line for the charging of a battery; and,

where the mobile device is configured to detect an identification signal at a D+ and a D- data line of the USB interface, the identification signal being different than USB enumeration.

2. The mobile device of claim 1 wherein the identification signal comprises a voltage level that is applied to at least one data line in the USB connector.

3. The mobile device of claim 1 wherein the identification signal is a result of using a resistance between the D+ and D- data lines.

4. The mobile device of claim 1 wherein the identification subsystem comprises a hard-wired connection of a voltage level to one or more data lines in the USB connector.

5. A mobile device, the mobile device configurable for use in a wireless telecommunications network, comprising:

a Universal Serial Bus ("USB") interface configured to allow reception of a USB cable;

a charging subsystem, the charging subsystem operably connected to the USB interface V-bus power line;

the charging subsystem operably connectable to a battery, and configurable to charge a battery;

the charging system further configured to use power from the V-bus power line for the charging of a battery;

where data lines D+ and D- at the USB interface are configured to receive signals;

a microprocessor and memory usable to process the received signals, configured such that before USB enumeration an identification signal received at the D+ and D- lines indicating a charging connection is available is recognized by the device.

6. The mobile device of claim 5 wherein the identification signal comprises a voltage level that is applied to at least one data line in the USB connector.

7. The mobile device of claim 5 wherein the identification signal is a result of using a resistance between the D+ and D- data lines.

8. A method of charging a battery in a mobile device, the mobile device configurable for use in a wireless telecommunications network, comprising:

providing a Universal Serial Bus ("USB") interface configured to allow reception of a USB cable, and, receiving power on a V-bus power line at the USB interface;

providing an operable connection between the power received at the USB interface on the V-bus power line and a charging subsystem;

having a battery in operable connection to the charging subsystem;

providing power to the battery using the charger subsystem; and,

detecting an identification signal at a D+ and a D- data line of the USB interface, the identification signal being different than USB enumeration.

9. The method claim 8 wherein the identification signal comprises a voltage level at least one data line in the USB connector.

10. The method claim 8 wherein the identification signal is a result of using a resistance between the D+ and D- data lines.

11. A method for charging a battery in a mobile device, the mobile device configurable for use in a wireless telecommunications network, comprising:

providing a Universal Serial Bus ("USB") interface configured to allow reception of a USB cable, and, to receiving power on a V-bus power line at the USB interface;

providing an operable connection between the power received at the USB interface on the V-bus power line and a charging subsystem;

having a battery in operable connection to the charging subsystem;

providing power to the battery using the charger subsystem in one of a plurality of charge modes;

using a microprocessor and memory to process the signals received on the USB interface data lines, such that an identification signal received at the D+ and D- lines indicating a charging connection is available is recognized by the device.

12. The method claim 11 wherein the identification signal comprises a voltage level at least one data line in the USB connector.

13. The method claim 11 wherein the identification signal is a result of using a resistance between the D+ and D- data lines.

ABSTRACT

An adapter for providing a source of power to a mobile device through an industry standard port is provided. In accordance with one aspect of the invention, the adapter comprises a plug unit, a power converter, a primary connector, and an identification subsystem. The plug unit is operative to couple the adapter to a power socket and operative to receive energy from the power socket. The power converter is electrically coupled to the plug unit and is operable to regulate the received energy from the power socket and to output a power requirement to the mobile device. The primary connector is electrically coupled to the power converter and is operative to couple to the mobile device and to deliver the outputted power requirement to the mobile device. The identification subsystem is electrically coupled to the primary connector and is operative to provide an identification signal.

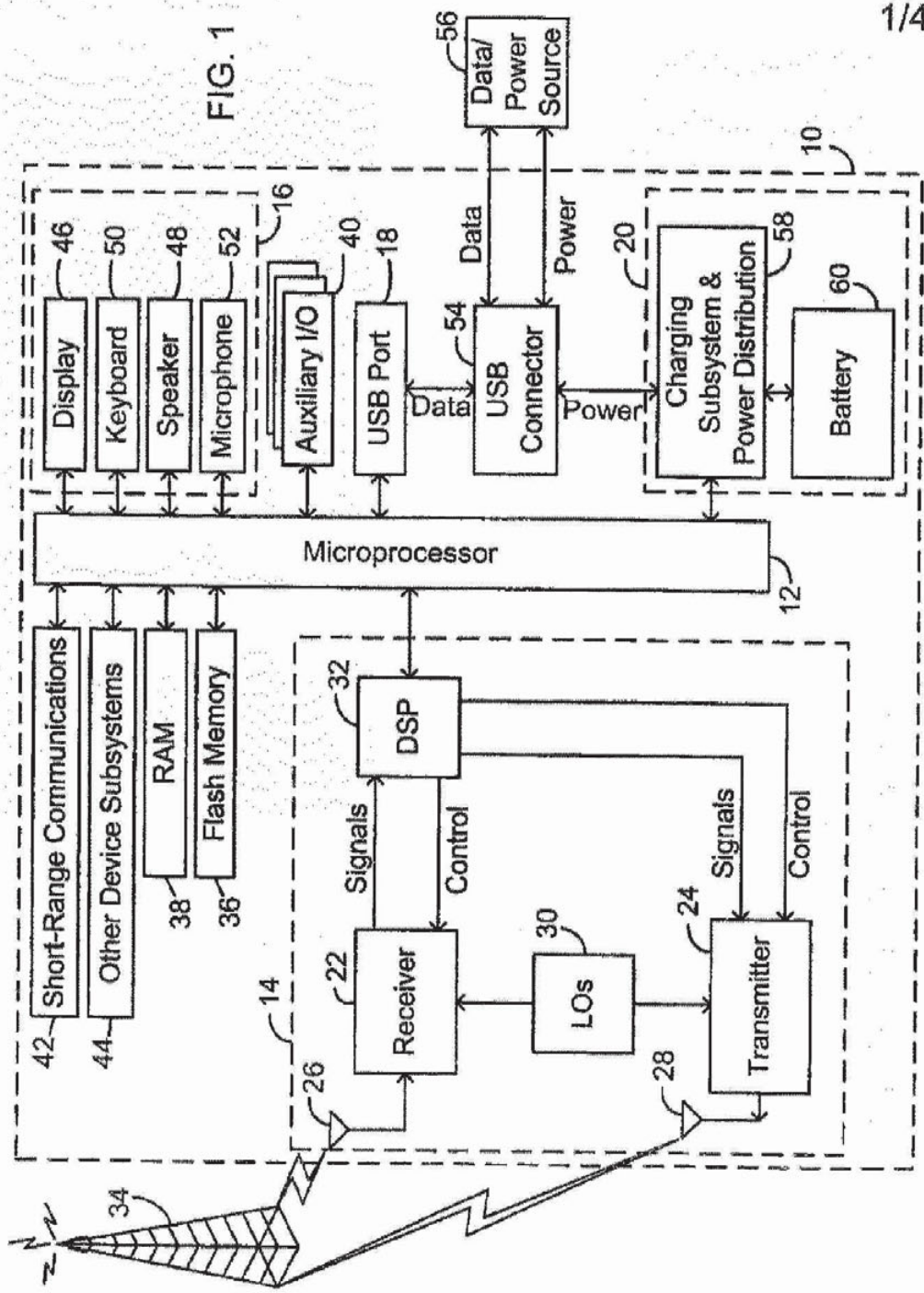

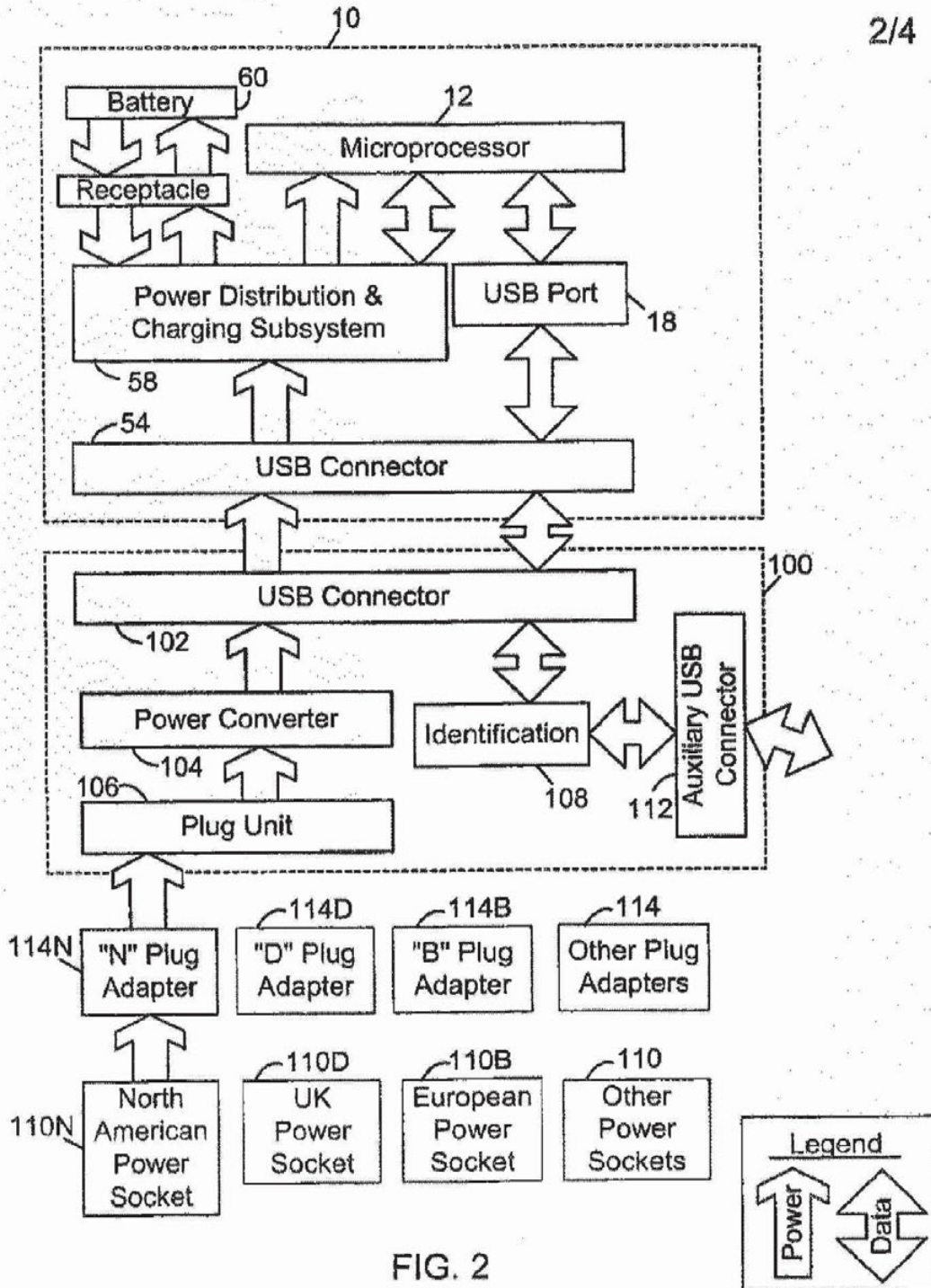

FIG. 2

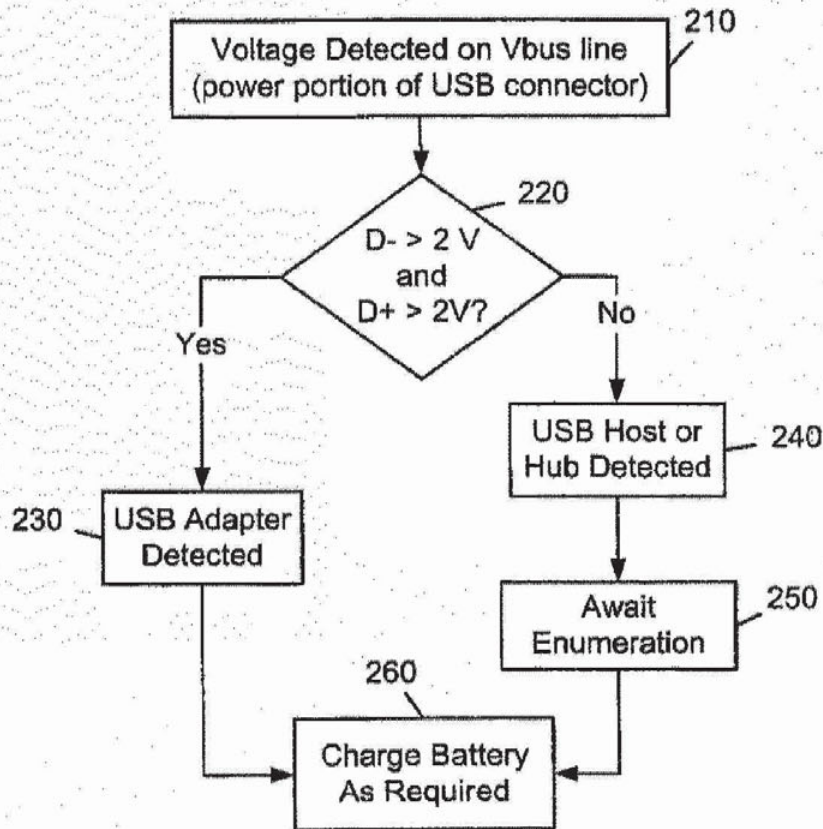
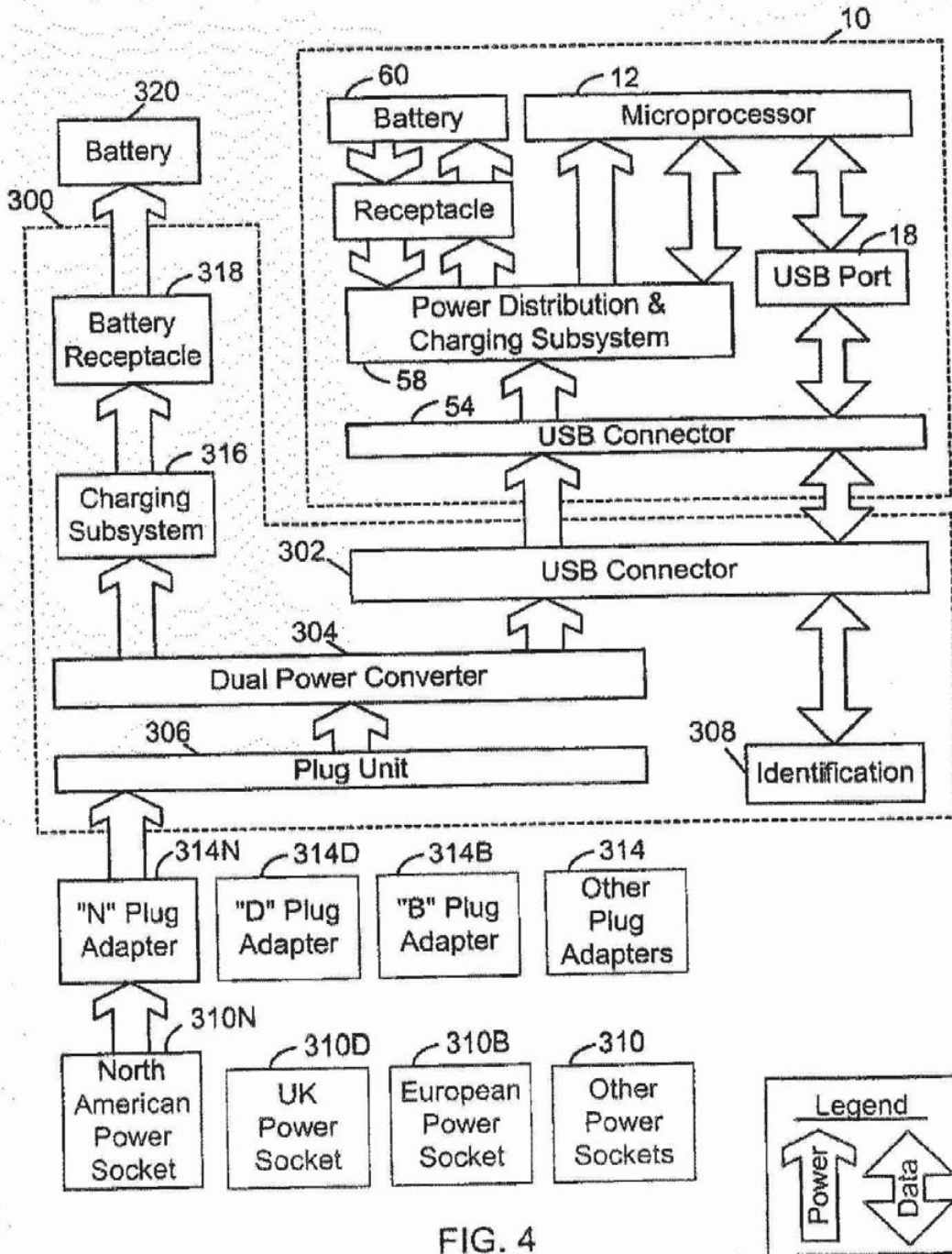

FIG. 3



DECLARATION FOR UTILITY OR DESIGN PATENT APPLICATION (37 CFR 1.63)	Attorney Docket Number 555255012294	
	First Named Inventor Daniel M. FISCHER	
	COMPLETE IF KNOWN	
	Application Number 10 / 087/629	
	Filing Date March 01/02	
	Group Art Unit	
<input type="checkbox"/> Declaration Submitted with Initial Filing	OR	<input checked="" type="checkbox"/> Declaration Submitted after Initial Filing (surcharge (37 CFR 1.16 (e)) required)
Examiner Name		

As a below named inventor, I hereby declare that:

My residence, mailing address, and citizenship are as stated below next to my name.

I believe I am the original, first and sole inventor (if only one name is listed below) or an original, first and joint inventor (if plural names are listed below) of the subject matter which is claimed and for which a patent is sought on the invention entitled:

MULTIFUNCTIONAL CHARGER SYSTEM AND METHOD

(Title of the Invention)

the specification of which

is attached hereto

OR

was filed on (MM/DD/YYYY) 03/01/2002 as United States Application Number or PCT International

Application Number 10/087,629 and was amended on (MM/DD/YYYY) (if applicable).

I hereby state that I have reviewed and understand the contents of the above identified specification, including the claims, as amended by any amendment specifically referred to above.

I acknowledge the duty to disclose information which is material to patentability as defined in 37 CFR 1.56, including for continuation-in-part applications, material information which became available between the filing date of the prior application and the national or PCT international filing date of the continuation-in-part application.

I hereby claim foreign priority benefits under 35 U.S.C. 119(a)-(d) or (f), or 356(b) of any foreign application(s) for patent, inventor's or plant breeder's rights certificate(s), or 365(a) of any PCT International application which designated at least one country other than the United States of America, listed below and have also identified below, by checking the box, any foreign application for patent, inventor's or plant breeder's rights certificate(s), or any PCT international application having a filing date before that of the application on which priority is claimed.

Prior Foreign Application Number(s)	Country	Foreign Filing Date (MM/DD/YYYY)	Priority Not Claimed	Certified Copy Attached?	
				YES	NO
			<input type="checkbox"/>	<input type="checkbox"/>	<input type="checkbox"/>
			<input type="checkbox"/>	<input type="checkbox"/>	<input type="checkbox"/>
			<input type="checkbox"/>	<input type="checkbox"/>	<input type="checkbox"/>
			<input type="checkbox"/>	<input type="checkbox"/>	<input type="checkbox"/>

Additional foreign application numbers are listed on a supplemental priority data sheet PTO/SB/02B attached hereto:

Burden Hour Statement: This form is estimated to take 21 minutes to complete. Time will vary depending upon the needs of the individual case. Any comments on the amount of time you are required to complete this form should be sent to the Chief Information Officer, U.S. Patent and Trademark Office, Washington, DC 20231. DO NOT SEND FEES OR COMPLETED FORMS TO THIS ADDRESS. SEND TO: Assistant Commissioner for Patents, Washington, DC 20231.

Under the Paperwork Reduction Act of 1995, no persons are required to respond to a collection of information unless it contains a valid OMB control number.

DECLARATION — Utility or Design Patent Application

Direct all correspondence to: Customer Number or Bar Code Label OR Correspondence address below

Name **F. Drexel Feeling, Esq.**

Address **Jones, Day, Reavis & Pogue
 North Point, 901 Lakeside Avenue**

City **Cleveland** State **Ohio** ZIP **44114-1180**

Country **USA** Telephone **(216) 586-3939** Fax **(216) 579-0212**

I hereby declare that all statements made herein of my own knowledge are true and that all statements made on information and belief are believed to be true; and further that these statements were made with the knowledge that willful false statements and the like so made are punishable by fine or imprisonment, or both, under 18 U.S.C. 1001 and that such willful false statements may jeopardize the validity of the application or any patent issued thereon.

NAME OF SOLE OR FIRST INVENTOR: A petition has been filed for this unsigned inventor

Given Name **Daniel M.** Family Name **FISCHER**
 (first and middle (if any)) (first and middle (if any)) or Surname

Inventor's Signature *D M Fischer* Date *Mar 1, 2002*

Residence: City **Waterloo** State **Ontario** Country **CANADA** Citizenship **Canadian**

Mailing Address **295 Phillip Street**

City **Waterloo** State **Ontario** ZIP **N2L 3W8** Country **CANADA**

NAME OF SECOND INVENTOR: A petition has been filed for this unsigned inventor

Given Name **Dan G.** Family Name **RADUT**
 (first and middle (if any)) (first and middle (if any)) or Surname

Inventor's Signature _____ Date _____

Residence: City **Waterloo** State **Ontario** Country **CANADA** Citizenship **Canadian**

Mailing Address **295 Phillip Street**

City **Waterloo** State **Ontario** ZIP **N2L 3W8** Country **CANADA**

Additional inventors are being named on the 2 supplemental Additional Inventor(s) sheet(s) PTO/SB/02A attached hereto.

Under the Paperwork Reduction Act of 1995, no persons are required to respond to a collection of information unless it contains a valid OMB control number.

DECLARATION	ADDITIONAL INVENTOR(S) Supplemental Sheet Page <u>1</u> of <u>2</u>
--------------------	---

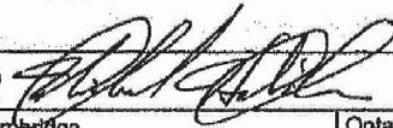
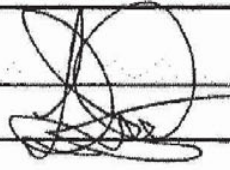
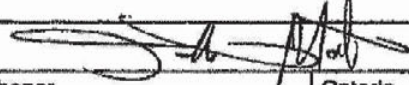
Name of Additional Joint Inventor, if any:		<input type="checkbox"/> A petition has been filed for this unsigned inventor	
Michael F. Given Name		HABICHER Family Name or Surname	
 Inventor's Signature		2002 - Feb - 28, Date	
Cambridge Residence: City	Ontario State	CANADA Country	Canadian Citizenship
295 Phillip Street Mailing Address			
Mailing Address			
Waterloo City	Ontario State	N2L 3W8 ZIP	CANADA Country
Name of Additional Joint Inventor, if any:		<input type="checkbox"/> A petition has been filed for this unsigned inventor	
Quang A. Given Name		LUONG Family Name or Surname	
 Inventor's Signature		Date Feb 28, 2002	
Kitchener Residence: City	Ontario State	CANADA Country	Canadian Citizenship
295 Phillip Street Mailing Address			
Mailing Address			
Waterloo City	Ontario State	N2L 3W8 ZIP	CANADA Country
Name of Additional Joint Inventor, if any:		<input type="checkbox"/> A petition has been filed for this unsigned inventor	
Jonathan T. Given Name		MALTON Family Name or Surname	
 Inventor's Signature		Date Feb 28 / 2002	
Kitchener Residence: City	Ontario State	CANADA Country	Canadian Citizenship
295 Phillip Street Mailing Address			
Mailing Address			
Waterloo City	Ontario State	N2L 3W8 ZIP	CANADA Country

Burden Hour Statement: This form is estimated to take 21 minutes to complete. Time will vary depending upon the needs of the individual case. Any comments on the amount of time you are required to complete this form should be sent to the Chief Information Officer, U.S. Patent and Trademark Office, Washington, DC 20231. DO NOT SEND FEES OR COMPLETED FORMS TO THIS ADDRESS. SEND TO: Assistant Commissioner for Patents, Washington, DC 20231.



UNITED STATES PATENT AND TRADEMARK OFFICE

S-0539
555255-012-294 C

COMMISSIONER FOR PATENTS
UNITED STATES PATENT AND TRADEMARK OFFICE
WASHINGTON, D.C. 20231
www.uspto.gov

DAN G. RADUT
300 REGINA STREET, NORTH
BUILDING 1, APT. 1207
WATERLOO, ONTARIO N2J 3B8
CANADA

COPY MAILED

SEP 09 2002

In re Application of
Fischer, et al.
Application No. 10/087,629
Filed: March 1, 2002
Attorney Docket No. 555255012294
For: MULTIFUNCTIONAL CHARGER SYSTEM:
AND METHOD

LETTER

OFFICE OF PETITIONS

Dear Sir:

You are named as an inventor in the above-identified United States patent application filed under the provisions of 35 U.S.C. 116 (United States Code) and 37 C.F.R. § 1.47(a), Rules of Practice in Patent Cases. Should a patent be granted on the application you will be designated therein as a joint inventor.

As a named inventor you are entitled to inspect any paper in the file wrapper of the application, order copies of all or any part thereof (at a prepaid cost as per 37 C.F.R. § 1.19) or make your position of record in the application. Alternatively, you may arrange to do any of the preceding through a registered patent attorney or agent presenting written authorization from you. If you care to join the application, counsel of record (see below) would presumably assist you. Joining in the application would entail the filing of an appropriate oath or declaration by you pursuant to 37 C.F.R. § 1.63.

Telephone inquiries regarding this communication should be directed to the undersigned at (703) 305-0310. Requests for information regarding your application should be directed to the File Information Unit at (703) 308-2733. Information regarding how to pay for and order a copy of the application, or a specific paper in the application, should be directed to Certification Division at (703) 308-9726 or 1-800-972-6382 (outside the Washington D.C. area).

Alesia M. Brown
Petitions Attorney
Office of Petitions
Office of the Deputy Commissioner
for Patent Examination Policy

CC: F. Drexel Feeling, Esq.
Jones, Day, Reavis & Pogue
901 Lakeside Avenue/North Point
Cleveland, OH 44114

**DOCKETED
COPY TO CLIENT**

FISI00001167

PATENT

Attorney Docket No. 555255012294

IN THE UNITED STATES PATENT AND TRADEMARK OFFICE

In re application of: Daniel M. Fischer, Dan G. Radut, Michael F. Habicher, Quang A. Luong, Jonathan T. Malton
Serial No.: 10/087,629
Filed: March 1, 2002
For: MULTIFUNCTIONAL CHARGER SYSTEM AND METHOD
Art Unit: Not yet assigned
Examiner: Not yet assigned

ASSISTANT COMMISSIONER OF PATENTS
WASHINGTON, D.C. 20231

PETITION FOR FILING BY OTHER THAN
ALL THE INVENTORS UNDER 37 CFR § 1.47

In accordance with 37 CFR § 1.47 and MPEP §409.03(a) and (d), applicants Fischer, Habicher, Luong, and Malton hereby petition the Assistant Commissioner to accept the filing of this patent application on behalf of themselves and the joint inventor, Dan G. Radut, who refuses to join in the application for patent. The petition fee of \$130 under 37 CFR § 1.17(I) accompanies this petition.

CERTIFICATE OF MAILING

I hereby certify that this correspondence is being deposited with the United States Postal Service as first class mail in an envelope addressed to: Commissioner for Patents, Washington, D.C. 20231 on the date indicated below.

Debra L. Pejeau
Name

July 29, 2002
Date

Debra L. Pejeau
Signature

Page 1 of 2

CL-692976v1

FISI00001168

Huawei v. FISI Exhibit No. 1002 - 198/208

As required by MPEP § 409.03(d), applicants enclose herein proof of the refusal of Mr. Radut to execute the application papers, in the form of a Declaration of David B. Cochran to whom the refusal to sign was made. In the Declaration, Mr. Cochran states that a bona fide attempt was made to present a copy of the application papers to Mr. Radut, and that Mr. Radut refused to sign the application papers. The Declaration by Mr. Cochran is deemed by the applicants to be sufficient proof of the refusal of Mr. Radut to sign.

In accordance with MPEP § 409.03(a) and (d), a Declaration signed by Messrs./Mmes. Fischer, Habicher, Luong and Malton with the signature block of Mr. Radut left blank is enclosed herein. The last known address of Mr. Radut is "300 Regina Street, North, Building 1, Apt. 1207, Waterloo, Ontario N2J 3B8 Canada."

The Assistant Commissioner is hereby authorized to charge any additional fees which may be required by this paper only to Jones, Day Reavis & Pogue Deposit Account No. 501432, order no. 555255012294.

Respectfully Submitted,

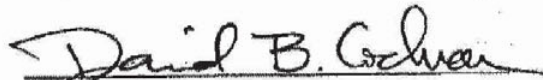

David B. Cochran
Registration No. 39,142
JONES, DAY, REAVIS & POGUE
901 Lakeside Avenue/North Point
Cleveland, OH 44114
(216) 586-3939

Date: 7/29/02

Page 2 of 2

CL-692976v1

FISI00001169

Huawei v. FISI Exhibit No. 1002 - 199/208

PATENT

Attorney Docket No. 555255012294

IN THE UNITED STATES PATENT AND TRADEMARK OFFICE

In re application of: Daniel M. Fischer, Dan G. Radut, Michael F. Habicher, Quang A. Luong, Jonathan T. Malton
Serial No.: 10/087,629
Filed: March 1, 2002
For: MULTIFUNCTIONAL CHARGER SYSTEM AND METHOD
Art Unit: Not yet assigned
Examiner: Not yet assigned

ASSISTANT COMMISSIONER OF PATENTS
WASHINGTON, D.C. 20231

DECLARATION OF DAVID B. COCHRAN

I hereby declare and state as follows:

1. I represent Research In Motion Limited ("RIM") in connection with the above-referenced patent application. This application names five inventors, Daniel M. Fischer, Dan G. Radut, Michael F. Habicher, Quang A. Luong, and Jonathan T. Malton.

2. Four of these inventors, Fischer, Habicher, Luong, and Malton, have signed the Declaration and Power of Attorney documents, which is being submitted to the USPTO along with this paper. Mr. Radut, however, who is no longer in the employ of RIM, refuses to sign the documents despite the fact that he signed an employment contract when beginning his employ obligating him to assist RIM in pursuing any such applications, even after his employment had ceased.

3. Prior to filing this application, a copy thereof was provided to each of the named inventors for their review and approval, including Mr. Radut.

Page 1 of 2

CL-692970v1

FISI00001170

Huawei v. FISI Exhibit No. 1002 - 200/208

4. On May 2, 2002, another copy of the application, along with the Declaration and Power of Attorney, was mailed to Mr. Radut's home address. Mr. Radut refused to sign the documents.

5. Between May 8 and May 15, 2002, Mr. Radut was contacted by telephone on several occasions regarding his willingness to sign the Declaration and Power of Attorney, and he refused to do so.

6. On June 19, 2002, I forwarded another copy of the application and the Declaration and Power of Attorney to Mr. Radut, again asking that he sign and return the papers, by June 27, 2002. I also called him on his home phone number to inquire as to whether he would be signing and returning the papers. He has refused to return any of my phone calls or to return the papers.

7. The last known address of Mr. Radut is 300 Regina Street, North, Building 1, Apt. 1207, Waterloo, Ontario N2J 3B8.

8. I hereby declare that all statements made herein of my own knowledge are true and that all statements made on information and belief are believed to be true; and further that these statements were made with knowledge that willful false statements and the like so made are punishable by fine or imprisonment, or both, under Section 1001 of Title 18 of the United States Code, and the such willful false testimony may jeopardize the validity of the application or any patent issuing thereon.

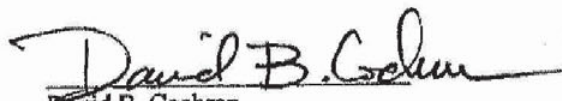
David B. Cochran

Under the Paperwork Reduction Act of 1995, no persons are required to respond to a collection of information unless it contains a valid OMB control number.

Application Data Sheet 37 CFR 1.76	Attorney Docket Number	10254-US-CNT4(4214-01509)
	Application Number	
Title of Invention	System and Method for Charging a Battery in a Mobile Device	
The application data sheet is part of the provisional or nonprovisional application for which it is being submitted. The following form contains the bibliographic data arranged in a format specified by the United States Patent and Trademark Office as outlined in 37 CFR 1.76. This document may be completed electronically and submitted to the Office in electronic format using the Electronic Filing System (EFS) or the document may be printed and included in a paper filed application.		

Secrecy Order 37 CFR 5.2

- Portions or all of the application associated with this Application Data Sheet may fall under a Secrecy Order pursuant to 37 CFR 5.2 (Paper filers only. Applications that fall under Secrecy Order may not be filed electronically.)

Applicant Information:

Applicant 1					Remove
Applicant Authority <input checked="" type="radio"/> Inventor		<input type="radio"/> Legal Representative under 35 U.S.C. 117		<input type="radio"/> Party of Interest under 35 U.S.C. 118	
Prefix	Given Name	Middle Name	Family Name	Suffix	
	Daniel	M.	FISCHER		
Residence Information (Select One) <input type="radio"/> US Residency <input checked="" type="radio"/> Non US Residency <input type="radio"/> Active US Military Service					
City	Waterloo	Country Of Residence¹	CA		
Citizenship under 37 CFR 1.41(b)¹		CA			
Mailing Address of Applicant:					
Address 1	295 Phillip Street				
Address 2					
City	Waterloo	State/Province	ON		
Postal Code	N2L 3W8	Country¹	CA		
Applicant 2					Remove
Applicant Authority <input checked="" type="radio"/> Inventor		<input type="radio"/> Legal Representative under 35 U.S.C. 117		<input type="radio"/> Party of Interest under 35 U.S.C. 118	
Prefix	Given Name	Middle Name	Family Name	Suffix	
	Dan	G.	RADUT		
Residence Information (Select One) <input type="radio"/> US Residency <input checked="" type="radio"/> Non US Residency <input type="radio"/> Active US Military Service					
City	Waterloo	Country Of Residence¹	CA		
Citizenship under 37 CFR 1.41(b)¹		CA			
Mailing Address of Applicant:					
Address 1	295 Phillip Street				
Address 2					
City	Waterloo	State/Province	ON		
Postal Code	N2L 3W8	Country¹	CA		
Applicant 3					Remove
Applicant Authority <input checked="" type="radio"/> Inventor		<input type="radio"/> Legal Representative under 35 U.S.C. 117		<input type="radio"/> Party of Interest under 35 U.S.C. 118	
Prefix	Given Name	Middle Name	Family Name	Suffix	
	Michael	F.	HABICHER		
Residence Information (Select One) <input type="radio"/> US Residency <input checked="" type="radio"/> Non US Residency <input type="radio"/> Active US Military Service					
City	Cambridge	Country Of Residence¹	CA		

Application Data Sheet 37 CFR 1.76		Attorney Docket Number	10254-US-CNT4(4214-01509)	
		Application Number		
Title of Invention	System and Method for Charging a Battery in a Mobile Device			
Citizenship under 37 CFR 1.41(b) i	CA			
Mailing Address of Applicant:				
Address 1	295 Phillip Street			
Address 2				
City	Waterloo	State/Province	ON	
Postal Code	N2L 3W8	Country ⁱ	CA	
Applicant 4				<input type="button" value="Remove"/>
Applicant Authority <input checked="" type="radio"/> Inventor <input type="radio"/> Legal Representative under 35 U.S.C. 117 <input type="radio"/> Party of Interest under 35 U.S.C. 118				
Prefix	Given Name	Middle Name	Family Name	Suffix
	Quang	A.	LUONG	
Residence Information (Select One) <input type="radio"/> US Residency <input checked="" type="radio"/> Non US Residency <input type="radio"/> Active US Military Service				
City	Kitchener	Country Of Residence ⁱ	CA	
Citizenship under 37 CFR 1.41(b) i		CA		
Mailing Address of Applicant:				
Address 1	295 Phillip Street			
Address 2				
City	Waterloo	State/Province	ON	
Postal Code	N2L 3W8	Country ⁱ	CA	
Applicant 5				<input type="button" value="Remove"/>
Applicant Authority <input checked="" type="radio"/> Inventor <input type="radio"/> Legal Representative under 35 U.S.C. 117 <input type="radio"/> Party of Interest under 35 U.S.C. 118				
Prefix	Given Name	Middle Name	Family Name	Suffix
	Jonathan	T.	MALTON	
Residence Information (Select One) <input type="radio"/> US Residency <input checked="" type="radio"/> Non US Residency <input type="radio"/> Active US Military Service				
City	Kitchener	Country Of Residence ⁱ	CA	
Citizenship under 37 CFR 1.41(b) i		CA		
Mailing Address of Applicant:				
Address 1	295 Phillip Street			
Address 2				
City	Waterloo	State/Province	ON	
Postal Code	N2L 3W8	Country ⁱ	CA	
All Inventors Must Be Listed - Additional Inventor Information blocks may be generated within this form by selecting the <input type="button" value="Add"/> button.				

Correspondence Information:

Enter either Customer Number or complete the Correspondence Information section below.
For further information see 37 CFR 1.33(a).

An Address is being provided for the correspondence information of this application.

Customer Number 30652

Application Data Sheet 37 CFR 1.76		Attorney Docket Number	10254-US-CNT4(4214-01509)
		Application Number	
Title of Invention	System and Method for Charging a Battery in a Mobile Device		
Email Address		<input type="button" value="Add Email"/>	<input type="button" value="Remove Email"/>

Application Information:

Title of the Invention	System and Method for Charging a Battery in a Mobile Device		
Attorney Docket Number	10254-US-CNT4(4214-01509)	Small Entity Status Claimed	<input type="checkbox"/>
Application Type	Nonprovisional		
Subject Matter	Utility		
Suggested Class (if any)		Sub Class (if any)	
Suggested Technology Center (if any)			
Total Number of Drawing Sheets (if any)	4	Suggested Figure for Publication (if any)	2

Publication Information:

<input type="checkbox"/>	Request Early Publication (Fee required at time of Request 37 CFR 1.219)
<input type="checkbox"/>	Request Not to Publish. I hereby request that the attached application not be published under 35 U.S.C. 122(b) and certify that the invention disclosed in the attached application has not and will not be the subject of an application filed in another country, or under a multilateral international agreement, that requires publication at eighteen months after filing.

Representative Information:

Representative information should be provided for all practitioners having a power of attorney in the application. Providing this information in the Application Data Sheet does not constitute a power of attorney in the application (see 37 CFR 1.32). Enter either Customer Number or complete the Representative Name section below. If both sections are completed the Customer Number will be used for the Representative Information during processing.			
Please Select One:	<input checked="" type="radio"/> Customer Number	<input type="radio"/> US Patent Practitioner	<input type="radio"/> Limited Recognition (37 CFR 11.9)
Customer Number	30652		

Domestic Benefit/National Stage Information:

This section allows for the applicant to either claim benefit under 35 U.S.C. 119(e), 120, 121, or 365(c) or indicate National Stage entry from a PCT application. Providing this information in the application data sheet constitutes the specific reference required by 35 U.S.C. 119(e) or 120, and 37 CFR 1.78(a)(2) or CFR 1.78(a)(4), and need not otherwise be made part of the specification.					
Prior Application Status		Patented	<input type="button" value="Remove"/>		
Application Number	Continuity Type	Prior Application Number	Filing Date (YYYY-MM-DD)	Patent Number	Issue Date (YYYY-MM-DD)
	Continuation of	11749680	2007-05-16	7453233	2008-11-18
Prior Application Status		Patented	<input type="button" value="Remove"/>		
Application Number	Continuity Type	Prior Application Number	Filing Date (YYYY-MM-DD)	Patent Number	Issue Date (YYYY-MM-DD)
11749680	Continuation of	11175885	2005-07-06	7239111	2007-07-03

Application Data Sheet 37 CFR 1.76		Attorney Docket Number	10254-US-CNT4(4214-01509)		
		Application Number			
Title of Invention		System and Method for Charging a Battery in a Mobile Device			
Prior Application Status		Pending		<input type="button" value="Remove"/>	
Application Number		Continuity Type		Prior Application Number	
		Continuation of		12268297	
Filing Date (YYYY-MM-DD)				2008-11-10	
Prior Application Status		Patented		<input type="button" value="Remove"/>	
Application Number		Continuity Type		Prior Application Number	
		Continuation of		11749680	
Filing Date (YYYY-MM-DD)				2007-05-16	
Patent Number				7453233	
Issue Date (YYYY-MM-DD)				2008-11-18	
Prior Application Status		Patented		<input type="button" value="Remove"/>	
Application Number		Continuity Type		Prior Application Number	
11749680		Continuation of		11175885	
Filing Date (YYYY-MM-DD)				2005-07-06	
Patent Number				7239111	
Issue Date (YYYY-MM-DD)				2007-07-03	
Prior Application Status		Patented		<input type="button" value="Remove"/>	
Application Number		Continuity Type		Prior Application Number	
10087692		non provisional of		60273021	
Filing Date (YYYY-MM-DD)				2001-03-01	
Patent Number				6936936	
Issue Date (YYYY-MM-DD)				2005-08-30	
Prior Application Status		Patented		<input type="button" value="Remove"/>	
Application Number		Continuity Type		Prior Application Number	
10087692		non provisional of		60330486	
Filing Date (YYYY-MM-DD)				2001-10-23	
Patent Number				6936936	
Issue Date (YYYY-MM-DD)				2005-08-30	
Additional Domestic Benefit/National Stage Data may be generated within this form by selecting the <input type="button" value="Add"/> button.					

Foreign Priority Information:

This section allows for the applicant to claim benefit of foreign priority and to identify any prior foreign application for which priority is not claimed. Providing this information in the application data sheet constitutes the claim for priority as required by 35 U.S.C. 119(b) and 37 CFR 1.55(a).

<input type="button" value="Remove"/>			
Application Number	Country ⁱ	Parent Filing Date (YYYY-MM-DD)	Priority Claimed
			<input type="radio"/> Yes <input checked="" type="radio"/> No
Additional Foreign Priority Data may be generated within this form by selecting the <input type="button" value="Add"/> button.			

Assignee Information:

Providing this information in the application data sheet does not substitute for compliance with any requirement of part 3 of Title 37 of the CFR to have an assignment recorded in the Office.

<input type="button" value="Remove"/>	
Assignee 1	
If the Assignee is an Organization check here. <input checked="" type="checkbox"/>	
Organization Name	Research In Motion Limited

Application Data Sheet 37 CFR 1.76		Attorney Docket Number	10254-US-CNT4(4214-01509)
		Application Number	
Title of Invention	System and Method for Charging a Battery in a Mobile Device		

Mailing Address Information:			
Address 1	295 Phillip Street		
Address 2			
City	Waterloo	State/Province	ON
Country	CA	Postal Code	N2L 3W8
Phone Number		Fax Number	
Email Address			
Additional Assignee Data may be generated within this form by selecting the Add button.			
			<input type="button" value="Add"/>

Signature:

A signature of the applicant or representative is required in accordance with 37 CFR 1.33 and 10.18. Please see 37 CFR 1.4(d) for the form of the signature.					
Signature	/J. Robert Brown, Jr./		Date (YYYY-MM-DD)	2010-02-26	
First Name	J. Robert	Last Name	Brown, Jr.	Registration Number	45438

This collection of information is required by 37 CFR 1.76. The information is required to obtain or retain a benefit by the public which is to file (and by the USPTO to process) an application. Confidentiality is governed by 35 U.S.C. 122 and 37 CFR 1.14. This collection is estimated to take 23 minutes to complete, including gathering, preparing, and submitting the completed application data sheet form to the USPTO. Time will vary depending upon the individual case. Any comments on the amount of time you require to complete this form and/or suggestions for reducing this burden, should be sent to the Chief Information Officer, U.S. Patent and Trademark Office, U.S. Department of Commerce, P.O. Box 1450, Alexandria, VA 22313-1450. DO NOT SEND FEES OR COMPLETED FORMS TO THIS ADDRESS. **SEND TO: Commissioner for Patents, P.O. Box 1450, Alexandria, VA 22313-1450.**

Privacy Act Statement

The Privacy Act of 1974 (P.L. 93-579) requires that you be given certain information in connection with your submission of the attached form related to a patent application or patent. Accordingly, pursuant to the requirements of the Act, please be advised that: (1) the general authority for the collection of this information is 35 U.S.C. 2(b)(2); (2) furnishing of the information solicited is voluntary; and (3) the principal purpose for which the information is used by the U.S. Patent and Trademark Office is to process and/or examine your submission related to a patent application or patent. If you do not furnish the requested information, the U.S. Patent and Trademark Office may not be able to process and/or examine your submission, which may result in termination of proceedings or abandonment of the application or expiration of the patent.

The information provided by you in this form will be subject to the following routine uses:

1. The information on this form will be treated confidentially to the extent allowed under the Freedom of Information Act (5 U.S.C. 552) and the Privacy Act (5 U.S.C. 552a). Records from this system of records may be disclosed to the Department of Justice to determine whether the Freedom of Information Act requires disclosure of these records.
2. A record from this system of records may be disclosed, as a routine use, in the course of presenting evidence to a court, magistrate, or administrative tribunal, including disclosures to opposing counsel in the course of settlement negotiations.
3. A record in this system of records may be disclosed, as a routine use, to a Member of Congress submitting a request involving an individual, to whom the record pertains, when the individual has requested assistance from the Member with respect to the subject matter of the record.
4. A record in this system of records may be disclosed, as a routine use, to a contractor of the Agency having need for the information in order to perform a contract. Recipients of information shall be required to comply with the requirements of the Privacy Act of 1974, as amended, pursuant to 5 U.S.C. 552a(m).
5. A record related to an International Application filed under the Patent Cooperation Treaty in this system of records may be disclosed, as a routine use, to the International Bureau of the World Intellectual Property Organization, pursuant to the Patent Cooperation Treaty.
6. A record in this system of records may be disclosed, as a routine use, to another federal agency for purposes of National Security review (35 U.S.C. 181) and for review pursuant to the Atomic Energy Act (42 U.S.C. 218(c)).
7. A record from this system of records may be disclosed, as a routine use, to the Administrator, General Services, or his/her designee, during an inspection of records conducted by GSA as part of that agency's responsibility to recommend improvements in records management practices and programs, under authority of 44 U.S.C. 2904 and 2906. Such disclosure shall be made in accordance with the GSA regulations governing inspection of records for this purpose, and any other relevant (i.e., GSA or Commerce) directive. Such disclosure shall not be used to make determinations about individuals.
8. A record from this system of records may be disclosed, as a routine use, to the public after either publication of the application pursuant to 35 U.S.C. 122(b) or issuance of a patent pursuant to 35 U.S.C. 151. Further, a record may be disclosed, subject to the limitations of 37 CFR 1.14, as a routine use, to the public if the record was filed in an application which became abandoned or in which the proceedings were terminated and which application is referenced by either a published application, an application open to public inspections or an issued patent.
9. A record from this system of records may be disclosed, as a routine use, to a Federal, State, or local law enforcement agency, if the USPTO becomes aware of a violation or potential violation of law or regulation.

Date: 02/26/10

Approved for use through 7/31/2006. OMB 0651-0032

U.S. Patent and Trademark Office; U.S. DEPARTMENT OF COMMERCE

Under the Paperwork Reduction Act of 1995, no persons are required to respond to a collection of information unless it displays a valid OMB control number.

PATENT APPLICATION FEE DETERMINATION RECORD Substitute for Form PTO-875				Application or Docket Number 12/714,204					
APPLICATION AS FILED - PART I (Column 1) (Column 2)				SMALL ENTITY		OR		OTHER THAN SMALL ENTITY	
	FOR	NUMBER FILED	NUMBER EXTRA	RATE (\$)	FEE (\$)		RATE (\$)	FEE (\$)	
	BASIC FEE (37 CFR 1.18(a), (b), or (c))	N/A	N/A	N/A			N/A	330	
	SEARCH FEE (37 CFR 1.18(k), (l), or (m))	N/A	N/A	N/A			N/A	540	
	EXAMINATION FEE (37 CFR 1.18(o), (p), or (q))	N/A	N/A	N/A			N/A	220	
	TOTAL CLAIMS (37 CFR 1.18(j))	13 minus 20 =		x\$26			x\$52		
	INDEPENDENT CLAIMS (37 CFR 1.18(n))	4 minus 3 =	1	x\$110			x\$220	220	
	APPLICATION SIZE FEE (37 CFR 1.16(s))	If the specification and drawings exceed 100 sheets of paper, the application size fee due is \$260 (\$130 for small entity) for each additional 50 sheets or fraction thereof. See 35 U.S.C. 41(a)(1)(G) and 37 CFR							
	MULTIPLE DEPENDENT CLAIM PRESENT (37 CFR 1.16(j))			195			390		
				TOTAL			TOTAL	1310	
* If the difference in column 1 is less than zero, enter "0" in column 2.									
APPLICATION AS AMENDED - PART II (Column 1) (Column 2) (Column 3)				SMALL ENTITY		OR		OTHER THAN SMALL ENTITY	
AMENDMENT A		CLAIMS REMAINING AFTER AMENDMENT	HIGHEST NUMBER PREVIOUSLY PAID FOR	PRESENT EXTRA	RATE (\$)	ADDITIONAL FEE (\$)	RATE (\$)	ADDITIONAL FEE (\$)	
	Total (37 CFR 1.16(i))	Minus **	=		X =		X =		
	Independent (37 CFR 1.16(h))	Minus ***	=		X =		X =		
	Application Size Fee (37 CFR 1.16(s))				N/A		N/A		
	FIRST PRESENTATION OF MULTIPLE DEPENDENT CLAIM (37 CFR 1.16(j))								
				TOTAL ADD'T FEE			TOTAL ADD'T FEE		
AMENDMENT B		CLAIMS REMAINING AFTER AMENDMENT	HIGHEST NUMBER PREVIOUSLY PAID FOR	PRESENT EXTRA	RATE (\$)	ADDITIONAL FEE (\$)	RATE (\$)	ADDITIONAL FEE (\$)	
	Total (37 CFR 1.16(i))	Minus **	=		X =		X =		
	Independent (37 CFR 1.16(h))	Minus ***	=		X =		X =		
	Application Size Fee (37 CFR 1.16(s))				N/A		N/A		
	FIRST PRESENTATION OF MULTIPLE DEPENDENT CLAIM (37 CFR 1.16(j))								
				TOTAL ADD'T FEE			TOTAL ADD'T FEE		
<p>* If the entry in column 1 is less than the entry in column 2, write "0" in column 3.</p> <p>** If the "Highest Number Previously Paid For" IN THIS SPACE is less than 20, enter "20".</p> <p>*** If the "Highest Number Previously Paid For" IN THIS SPACE is less than 3, enter "3".</p> <p>The "Highest Number Previously Paid For" (Total or Independent) is the highest number found in the appropriate box in column 1.</p>									

This collection of information is required by 37 CFR 1.16. The information is required to obtain or retain a benefit by the public which is to file (and by the USPTO to process) an application. Confidentiality is governed by 35 U.S.C 122 and 37 CFR 1.14. This collection is estimated to take 12 minutes to complete, including gathering, preparing, and submitting the completed application form to the USPTO. Time will vary depending upon the individual case. Any comments on the amount of time you require to complete this form and/or suggestions for reducing this burden, should be sent to the Chief Information Officer, U.S. Patent and Trademark Office, U.S. Department of Commerce, P.O. Box 1450, Alexandria, VA 22313-1450. DO NOT SEND FEES OR COMPLETED FORMS TO THIS ADDRESS. SEND TO: Commissioner for Patents, P.O. Box 1450, Alexandria, VA 22313-1450.

If you need assistance in completing the form, call 1-800-PTO-9199 and select option 2.