

04-22-03

10439621 1042103

04/21/03
1055 U.S. PTO

10439621
10/449621
1055 U.S. PTO
04/21/03

IN THE UNITED STATES PATENT AND TRADEMARK OFFICE UTILITY PATENT APPLICATION TRANSMITTAL

(For new non-provisional applications under 37 CFR § 1.53(b))

Atty. Dkt. No: 5266-06201 §
§
Inventor(s): §
Alain Delpuch §
James Whitledge §
Jean-Rene Menand §
Emmanuel Barbier §
Kevin Hausman §
Debra Hensgen §
Dongmin Su §
Title: SUPPORTING COMMON §
INTERACTIVE TELEVISION §
FUNCTIONALITY §
THROUGH PRESENTATION §
ENGINE SYNTAX §

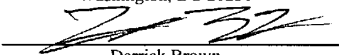
CERTIFICATE OF EXPRESS MAIL UNDER 37 C.F.R. §1.10	
"Express Mail" mailing label number:	EV 249056147 US
DATE OF DEPOSIT:	April 21, 2003
I hereby certify that this paper or fee is being deposited with the United States Postal Service "Express Mail Post Office to Addressee" service under 37 C.F.R. §1.10 on the date indicated above and is addressed to:	
Commissioner for Patents Box Patent Application Washington, DC 20231	
	
Derrick Brown	

Application Elements

1. Filing Fee
The filing fee is calculated as shown below.

Total Claims	23	- 20	=	3	x	\$18.00 =	\$54.00
Independent Claims	4	- 3	=	1	x	\$84.00 =	\$ 84.00
Multiple Dependent Claims	Fee:						
	Basic Fee:						\$ 750.00
	Total:						\$ 888.00

- The Commissioner is hereby authorized to charge the filing fee and any other fees which may be required or credit any overpayment to Meyertons, Hood, Kivlin, Kowert & Goetzl, P.C. Deposit Account No. 501505/5266-06201/RDR.
2. Specification
97 page(s) of specification; 4 page(s) of claims, 1 page(s) of abstract
3. Drawings
Formal Figure(s) 1-5 on 5 sheet(s)
4. Oath or Declaration
 Newly executed
 Copy from a prior application (see 37 C.F.R. § 1.63(d))
 Deletion of Inventor(s) (in continuation or divisional applications):
 Delete the following inventor(s) named in the prior non-provisional application:

 The inventor(s) to be deleted are set forth on a signed sheet attached hereto.
5. The entire disclosure of the prior application referred to above is considered to be part of the accompanying application and is hereby incorporated by reference herein.

- 6. Microfiche Computer Program (Appendix)
- 7. Nucleotide and/or Amino Acid Sequence Submission (if applicable, all necessary)
 - Computer Readable copy
 - Paper Copy (identical to computer copy)
 - Statement verifying identity of above copies
- 8. Assignment Papers
 - Copy from a prior application (see 37 C.F.R. § 1.63(d)).
- 9. Power of Attorney
 - Is attached.
 - The power of attorney appears in the original papers of the prior application.
 - Since the power does not appear in the original papers, a copy of the power in the prior application is enclosed.
- 10. Information Disclosure Statement (IDS)
 - Copies of IDS Citations
- 11. Amendments
 - A preliminary amendment is enclosed.
 - Cancel in this application claim(s) _____ before calculating the filing fee. At least one independent claim is retained for filing purposes.
 - Amend the specification by inserting before the first line the sentence: **This application claims the benefit of U.S. Provisional Application No. 60/373,883 entitled "Supporting Common Interactive Television Functionality Through Presentation Engine Syntax", filed April 19, 2002.**
- 12. Return Receipt Postcard
- 13. Small Entity Status
 - A small entity statement is enclosed.
 - A small entity statement was filed in the prior non-provisional application and such status is still proper and desired.
 - Is no longer claimed.
- 14. Priority of provisional application number 60/373,883, filed on April 19, 2002 is claimed under 35 U.S.C. §§ 119(a)-(e)
- 15. Petition under 37 C.F.R. § 136 for Extension of Time
- 16. Fee Authorization form

Address all future correspondence to:
 Rory D. Rankin
 Meyertons, Hood, Kivlin, Kowert & Goetzel, P.C.
Customer ID #35690
 P.O. Box 398
 Austin, Texas 78767
 (512) 853-8800; Fax (512) 853-8801

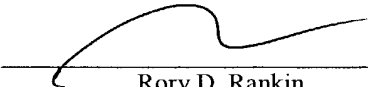
Signature	
Name	_____ Rory D. Rankin
Registration No.	47,884
Date	_____ 4/21/03

**IN THE UNITED STATES PATENT AND TRADEMARK OFFICE
UTILITY PATENT APPLICATION TRANSMITTAL**

(For new non-provisional applications under 37 CFR § 1.53(b))

Atty. Dkt. No: 5266-06201 §
 Inventor(s): §
 Alain Delpuch §
 James Whitledge §
 Jean-Rene Menand §
 Emmanuel Barbier §
 Kevin Hausman §
 Debra Hensgen §
 Dongmin Su §
 Title: SUPPORTING COMMON §
 INTERACTIVE TELEVISION §
 FUNCTIONALITY §
 THROUGH PRESENTATION §
 ENGINE SYNTAX §

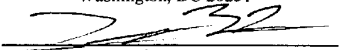
<p>CERTIFICATE OF EXPRESS MAIL UNDER 37 C.F.R. §1.10</p> <p>"Express Mail" mailing label number: <u>EV 249056147 US</u> DATE OF DEPOSIT: <u>April 21, 2003</u></p> <p>I hereby certify that this paper or fee is being deposited with the United States Postal Service "Express Mail Post Office to Addressee" service under 37 C.F.R. §1.10 on the date indicated above and is addressed to:</p> <p align="center">Commissioner for Patents Box Patent Application Washington, DC 20231</p>  Derrick Brown
--

FEE AUTHORIZATION

Commissioner for Patents
Washington, D.C. 20231

The Commissioner is hereby authorized to charge the following fee to Meyertons, Hood, Kivlin, Kowert & Goetzl, P.C. Deposit Account Number 501505/5266-06201/RDR:

Total Claims	23	- 20	= 3	x	\$18.00	=	\$54.00
Independent Claims	4	- 3	= 1	x	\$84.00	=	\$ 84.00
Multiple Dependent Claims					Fee:		
					Basic Fee:		\$ 750.00
					Total:		\$ 888.00

Attorney Docket No.: 5266-06201

The Commissioner is also authorized to charge any extension fee or other fees which may be necessary to the same account number.

Signature _____
 Name Rory D. Rankin
 Registration No. 47,884
 Date 4/21/03

04-22-03

10419621 104210

04/21/03
11055 U.S. PTO

11036 U.S. PTO
10/449621
04/21/03

IN THE UNITED STATES PATENT AND TRADEMARK OFFICE
UTILITY PATENT APPLICATION TRANSMITTAL
(For new non-provisional applications under 37 CFR § 1.53(b))

Atty. Dkt. No: 5266-06201 §
Inventor(s): §
Alain Delpuch §
James Whitledge §
Jean-Rene Menand §
Emmanuel Barbier §
Kevin Hausman §
Debra Hensgen §
Dongmin Su §
Title: SUPPORTING COMMON §
INTERACTIVE TELEVISION §
FUNCTIONALITY §
THROUGH PRESENTATION §
ENGINE SYNTAX §

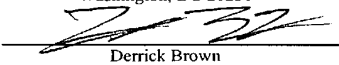
CERTIFICATE OF EXPRESS MAIL
UNDER 37 C.F.R. §1.10
"Express Mail" mailing label number: EV 249056147 US
DATE OF DEPOSIT: April 21, 2003
I hereby certify that this paper or fee is being deposited with the United States Postal Service "Express Mail Post Office to Addressee" service under 37 C.F.R. §1.10 on the date indicated above and is addressed to:
Commissioner for Patents
Box Patent Application
Washington, DC 20231

Derrick Brown

Application Elements

1. Filing Fee
The filing fee is calculated as shown below.

Total Claims	23	- 20	= 3	x	\$18.00 =	\$54.00
Independent Claims	4	- 3	= 1	x	\$84.00 =	\$ 84.00
Multiple Dependent Claims					Fee:	
					Basic Fee:	\$ 750.00
					Total:	\$ 888.00

- The Commissioner is hereby authorized to charge the filing fee and any other fees which may be required or credit any overpayment to Meyertons, Hood, Kivlin, Kowert & Goetzel, P.C. Deposit Account No. 501505/5266-06201/RDR.
2. Specification
97 page(s) of specification; 4 page(s) of claims, 1 page(s) of abstract
3. Drawings
Formal Figure(s) 1-5 on 5 sheet(s)
4. Oath or Declaration
 Newly executed
 Copy from a prior application (see 37 C.F.R. § 1.63(d))
Deletion of Inventor(s) (in continuation or divisional applications):
 Delete the following inventor(s) named in the prior non-provisional application:

 The inventor(s) to be deleted are set forth on a signed sheet attached hereto.
5. The entire disclosure of the prior application referred to above is considered to be part of the accompanying application and is hereby incorporated by reference herein.

- 6. Microfiche Computer Program (Appendix)
- 7. Nucleotide and/or Amino Acid Sequence Submission (if applicable, all necessary)
 - Computer Readable copy
 - Paper Copy (identical to computer copy)
 - Statement verifying identity of above copies
- 8. Assignment Papers
 - Copy from a prior application (see 37 C.F.R. § 1.63(d)).
- 9. Power of Attorney
 - Is attached.
 - The power of attorney appears in the original papers of the prior application.
 - Since the power does not appear in the original papers, a copy of the power in the prior application is enclosed.
- 10. Information Disclosure Statement (IDS)
 - Copies of IDS Citations
- 11. Amendments
 - A preliminary amendment is enclosed.
 - Cancel in this application claim(s) _____ before calculating the filing fee. At least one independent claim is retained for filing purposes.
 - Amend the specification by inserting before the first line the sentence: **This application claims the benefit of U.S. Provisional Application No. 60/373,883 entitled "Supporting Common Interactive Television Functionality Through Presentation Engine Syntax", filed April 19, 2002.**
- 12. Return Receipt Postcard
- 13. Small Entity Status
 - A small entity statement is enclosed.
 - A small entity statement was filed in the prior non-provisional application and such status is still proper and desired.
 - Is no longer claimed.
- 14. Priority of provisional application number 60/373,883, filed on April 19, 2002 is claimed under 35 U.S.C. §§ 119(a)-(e)
- 15. Petition under 37 C.F.R. § 136 for Extension of Time
- 16. Fee Authorization form

Address all future correspondence to:
 Rory D. Rankin
 Meyertons, Hood, Kivlin, Kowert & Goetzel, P.C.
Customer ID #35690
 P.O. Box 398
 Austin, Texas 78767
 (512) 853-8800; Fax (512) 853-8801

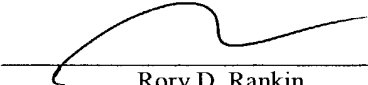
Signature	
Name	Rory D. Rankin
Registration No.	47,884
Date	4/21/03

**IN THE UNITED STATES PATENT AND TRADEMARK OFFICE
UTILITY PATENT APPLICATION TRANSMITTAL**

(For new non-provisional applications under 37 CFR § 1.53(b))

Atty. Dkt. No: 5266-06201 §
 Inventor(s): §
 Alain Delpuch §
 James Whitlege §
 Jean-Rene Menand §
 Emmanuel Barbier §
 Kevin Hausman §
 Debra Hensgen §
 Dongmin Su §
 Title: SUPPORTING COMMON §
 INTERACTIVE TELEVISION §
 FUNCTIONALITY §
 THROUGH PRESENTATION §
 ENGINE SYNTAX §

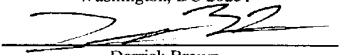
<p>CERTIFICATE OF EXPRESS MAIL UNDER 37 C.F.R. §1.10</p> <p>"Express Mail" mailing label number: <u>EV 249056147 US</u> DATE OF DEPOSIT: <u>April 21, 2003</u></p> <p>I hereby certify that this paper or fee is being deposited with the United States Postal Service "Express Mail Post Office to Addressee" service under 37 C.F.R. §1.10 on the date indicated above and is addressed to:</p> <p align="center">Commissioner for Patents Box Patent Application Washington, DC 20231</p> <p align="center"> Derrick Brown</p>

FEE AUTHORIZATION

Commissioner for Patents
Washington, D.C. 20231

The Commissioner is hereby authorized to charge the following fee to Meyertons, Hood, Kivlin, Kowert & Goetzel, P.C. Deposit Account Number 501505/5266-06201/RDR:

Total Claims	23	- 20	= 3	x	\$18.00	=	\$54.00
Independent Claims	4	- 3	= 1	x	\$84.00	=	\$ 84.00
Multiple Dependent Claims	Fee:						
	Basic Fee:						\$ 750.00
	Total:						\$ 888.00

Attorney Docket No.: 5266-06201

The Commissioner is also authorized to charge any extension fee or other fees which may be necessary to the same account number.

Signature _____
 Name Rory D. Rankin
 Registration No. 47,884
 Date 4/21/03

**PATENT
5266-06201
OPTV-187**

"EXPRESS MAIL" MAILING LABEL
NUMBER EV 249056147 US
DATE OF DEPOSIT APRIL 21, 2003

I HEREBY CERTIFY THAT THIS PAPER OR
FEE IS BEING DEPOSITED WITH THE
UNITED STATES POSTAL SERVICE
"EXPRESS MAIL POST OFFICE TO
ADDRESSEE" SERVICE UNDER 37 C.F.R. §
1.10 ON THE DATE INDICATED ABOVE
AND IS ADDRESSED TO THE
COMMISSIONER OF PATENTS AND
TRADEMARKS, WASHINGTON, D.C. 20231

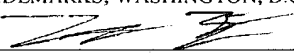
DERRICK BROWN

**Supporting Common Interactive Television Functionality
Through Presentation Engine Syntax**

By:

Alain Delpuch
James Whitledge
Jean-Rene Menand
Emmanuel Barbier
Kevin Hausman
Debra Hensgen
Dongmin Su

BACKGROUND OF THE INVENTION

Field of the Invention

The invention relates generally to interactive television systems and more particularly to a system and method for creating and controlling interactive television content.

Description of Related Art

Interactive television systems provide a means to deliver interactive content as well as ordinary television audio and video to a large number of subscribers. Programs broadcast by these systems may incorporate television audio and video, still images, text, interactive graphics and applications, and many other components. They may also provide a number of services, such as commerce via the television, electronic program guides (EPGs), video-on-demand, and other interactive applications to viewers. The interactive content of the interactive television signal may therefore include application code, data associated with the audio and video, control signals, raw data and many other types of information. This information can be combined into a single signal or several signals for transmission to a receiver connected to the viewer's television or the provider can include only a subset of the information.

The interactive functionality of the television is generally controlled by an integrated receiver/decoder (IRD) or similar mechanism, frequently incorporated into a set-top box, connected to the television. The IRD receives the signal provided by a broadcast service provider or system operator and separates the interactive portion from the audio-video portion. The IRD uses the interactive information to, for example, execute an application while the audio-video information is transmitted to the television. The IRD may combine the audio-video information with interactive graphics or audio

generated by the interactive application prior to transmitting the information to the television.

Interactive content such as application code or information relating to television programs may be broadcast in a cyclical or repeating format. The pieces of information which are broadcast in this manner form what may be referred to as a "carousel." A carousel may include multiple modules of data, including a directory module which indicates the particular modules which correspond to a given application. Frequently, a single carousel is transported as a contiguous data stream. However, it is also possible to multiplex two or more carousels in a single data stream. As an alternative to using a carousel format, some systems may utilize a return path to request and/or receive interactive content.

Broadcast systems may transmit information in a carousel format in order to allow receivers in the system to selectively obtain particular pieces of information in the carousel without requiring a return path from the receivers to the server. If a particular receiver needs a particular piece of information, it can simply wait until the next time that piece of information is broadcast, and then extract the information from the broadcast data stream. By employing carousels to broadcast information, the system may eliminate the need to connect each of the receivers with a server and further eliminate the need for the server to process individual requests for information.

The pieces of information, or data objects, in a carousel may be intended to be combined in a single object data stream to form a program. This program may also contain streaming data such as audio or video. For example, an interactive television game show may combine television audio and video with interactive content such as application code which allows users to answer questions. Another example would be a news program which combines audio and video with application code that inserts current stock prices in a banner at the bottom of the screen. Typically, each program is associated with a corresponding channel and, when a channel containing a particular

program is selected by the interactive television receiver, the data which is being broadcast on that channel is downloaded and the program is started.

As television receivers become more sophisticated, and include the ability to access a wider range of data and resources, efforts have been made to develop mechanisms to handle these additional resources. For example, the DVB MHP 1.1 specification and DAVIC 1.4.1 Part 9 specification define a URL scheme to access broadcast services. Since DAVIC broadcast networks carry Service Information (SI) that contains globally unique parameters for locating the services in a broadcast network, their URL scheme is able to address services in a physical network independent manner.

Unfortunately, such schemes may not work on ATSC networks or other networks that define different or even proprietary signaling formats. Therefore, a new more flexible scheme is desired.

SUMMARY OF THE INVENTION

A method and mechanism are described which enable content authors to use directives, such as HTML, scripting languages, or other languages, with television extensions to create and/or control interactive television content. The method and mechanism may be utilized with digitally recorded programs as well as with live broadcasts.

In one embodiment, a device in an interactive television system is configured to receive one or more directives provided by a content author which describe or otherwise indicate an audio and/or video presentation. Included among these directives are one or more directives which indicate that a particular subset of resources required for the presentation are deemed prerequisites. In response to detecting these directives, the providing of the presentation is withheld until the prerequisite resources are obtained.

In one embodiment, the directives are received by a centrally located proxy server which may be configured to receive, transcode and convey transcoded web based content to client devices. Upon detecting directives which indicate prerequisite resources for a presentation, the proxy server separately conveys to the client devices signals, or some other indication, that these resources are prerequisites. In response, the client device receiving the conveyed signals may take actions to prefetch these resources.

BRIEF DESCRIPTION OF THE DRAWINGS

Fig. 1 is a diagram of one embodiment of a broadcast television system.

Fig. 2 is a diagram of one embodiment of a headend.

Fig. 3 is a block diagram of one embodiment of a client device.

Fig. 4 is a diagram of one embodiment of a television system.

Fig. 5 illustrates one embodiment of a method utilizing prerequisite directives.

DETAILED DESCRIPTION

0. System Overview

Referring to Fig. 1, one embodiment of a television system 100 is shown. In the embodiment shown, receiving devices 30 are coupled to several sources of programming and/or interactive content. Each of receiving devices 30 may comprise any suitable device, such as a set-top box (STB), a television (TV), a video cassette recorder (VCR), a digital video recorder (DVR), a personal digital assistant (PDA), a personal computer (PC), a video game console, or a mobile/cell phone.

Included in the embodiment of Fig. 1 is a broadcast station 16 coupled to receiver(s) 30 via a transmission medium 17 and back channel 26. In addition, receiver(s) 30 are coupled to a source 18 and source 19 via a network 20. Further, broadcast station 16 is coupled to a remote source 13, and Internet 60. In the embodiment shown, broadcast station 16 includes sources 14 and 15 and transmitter 22. Transmission medium 17 may comprise a satellite based system 23, a cable based system 24, a terrestrial or multiple multi-point distribution service (MMDS) based system 25, a combination of these systems, or some other suitable system of transmission.

In the embodiment of Fig. 1, broadcast station 16 may include a variety of sources of content 14, 15, and 60 to be utilized and conveyed by transmitter 22. Content sources 14 and 15 may include databases, application servers, other audio/video sources, or other data sources. In one embodiment, content may be created at a source 14 which may include an authoring station configured to create such content. An authoring station may include a computer workstation configured with software which aids in the development of interactive content. An authoring station may be part of broadcast station 16 in which case the conveyance of the created content may be through a local computing network, or similar configuration. Alternatively, an authoring station may be remotely located 13 from broadcast station 16. In an embodiment where authoring station is not directly

coupled to broadcast station 16, the content created by a source 13 may be conveyed to broadcast station 16 via Internet, broadcast, cable, etc. In some cases, content created by at a remote location 13 may first be transferred to a storage medium, such as a CD-RW, DVD, or flash memory device, and transported to broadcast station 16 via more conventional means where it may be stored in a database or other storage device.

Subsequent to its creation, content from sources 13, 14, 15 and 60 may be delivered to receiver(s) 30 through a broadcast transmission network. This network consists essentially of broadcast station 16 which assembles the content from sources 13, 14, 15 and 60 and processes the content as appropriate (e.g., digitizes, compresses, packetizes), and a transmission network 17 which receives the content 40 from broadcast station 16 and conveys it 42 to receiving device(s) 30. In one embodiment, broadcast station 16 includes software and/or hardware which is configured to process the content conveyed by sources 13, 14, 15 and 60 as described above. A second delivery mechanism may include a direct point-to-point connection 138 between receiver(s) 30 and source 18 which may be some type of server. This connection 138 may be made via an ordinary telephone line, cable, wireless, or otherwise. A third delivery mechanism may also be a point-to-point connection 136, but transmission of the content from a source 19 to receiver(s) 30 is made via one or more shared networks (e.g., over the Internet).

Fig. 1 also illustrates broadcast station 16 may be optionally coupled to source 18 and/or source 19. Such a coupling may enable broadcast station 16 to work cooperatively with source 18 or source 19 in conveying content to receiver(s) 30. Also illustrated in Fig. 1 is a back channel (or return path) 26 by which receiver(s) 30 may convey to and/or receive data from broadcast station 16. Back channel 26 may comprise a telephone line, cable, wireless, or other connection.

One delivery mechanism, the direct point-to-point connection to a source of content, may comprise communication via an ordinary telephone line. This type of connection is typically initiated by the receiver(s) 30 to convey information to, or retrieve information from, a data server. Another delivery mechanism, the point-to-point

connection through one or more networks, may comprise a typical connection between nodes on the Internet. Because data may be routed through many different shared networks in this case, it may be read, stored and written many times as it is transmitted from source 19 to receiver(s) 30. The third delivery mechanism may include a satellite, cable or terrestrial broadcast network 17. Information may be transmitted from and to receiver(s) 30 both in real time or store and forward.

In one embodiment, broadcast station 16 further includes a proxy server 21 which is configured to transcode received content to a format compatible with one or more of client devices 30. For example, proxy 21 may receive web based content including directives written in HTML, JavaScript™ (JavaScript is a trademark of Sun Microsystems, Inc), CSS, or other languages, and transcode the received content to a format compatible with clients 30. In alternative embodiment, clients may be configured to directly process such directives. In such a case, proxy 21 may be configured to perform certain types of preprocessing of the content prior to conveyance to the clients.

Turning now to Fig. 2, an overview of one embodiment of a broadcast station (head-end) 16 is shown. The broadcast station 16 of Fig. 2 includes an application server 250 and a database 230 which may contain previously created interactive content. Also shown in Fig. 2 is a source 13 of content (e.g., the Internet) which is external to broadcast station 16 and coupled to broadcast station 16. Database 230, server 250, Internet 60, and source 13 are coupled to a content processing mechanism 200 which is configured to process the content received and convey the processed content to a multiplexor 220. In the exemplary embodiment of Fig. 2, proxy server 21 includes server 250 and processing mechanism 200.

In one embodiment, content processing mechanism 200 comprises a computer coupled to receive and convey content from source 13, database 230, or server 250. Processing mechanism 200 is configured to convey the processed content to multiplexor 220. Multiplexor 220 is also coupled to receive audio/video signals 240. Multiplexor 220 multiplexes the received signals and conveys the multiplexed signal to network

communications operator 17 where it is subsequently conveyed to a receiving device. As noted above, proxy 21 may be configured to process received content prior to conveying the content to client devices. For example, proxy 21 may be configured to receive requests from clients for web based content, obtain the requested content, and transcode the received content to an alternate format prior to conveyance to the requesting client. Finally, in addition to the above, broadcast station 16 includes a return data processor 210 coupled to back channel 26. In one embodiment, return data processor 210 may comprise a modem which receives data for further processing within broadcast station 16.

While the above description describes a source of interactive content as being at a broadcast station 16, in an alternative embodiment database 230 and content processing mechanism 200 may reside at the location of a network communications operator 17. An example of such an alternative embodiment may be a cable station which inserts interactive content into a broadcast signal prior to transmission. Numerous such alternatives are possible and are contemplated.

Turning now to Fig. 3, one embodiment of a receiving/initiating device 1012, hereinafter referred to as a “client” is shown. While Fig. 3 illustrates the client 1012 in the form of a set top box 1012, client 1012 may comprise other devices as well. Generally speaking, client 1012 is configured to receive a first signal 1070, such as a broadcast signal, and convey a second signal 1080, such as to a display or recording device. While in the embodiment shown, client 1012 is shown coupled to an external mass storage device 1018, such storage may be internal to the client 1012 itself. Client 1012 includes a control unit 1030, front end 1026, return channel 1038, transport stage 1028, and AV stage 1034. Also represented in Fig. 3 is a memory 1080 which includes OS and/or middleware 1044, message processing engine 1036, and applications 1042. Also shown is an I/O interface 1040 and conditional access (CA) module(s) 1032. I/O interface 1040 may be configured to detect user interaction via a remote control, keyboard, or other device. Control unit 1030 may comprise a microprocessor, memory (e.g., RAM), and other components which are necessary to perform ordinary general purpose computing.

In one embodiment, applications 1042, OS/middleware 1044, CA module(s) 1032, and message processing engine 1036 comprise code which may be stored in a memory device of set-top box 1012. Additionally, CA module(s) 1032 may comprise system software configured to control access to particular programs or services which are accessible by set-top box 1012. While message processing engine 1036 is shown as program code which may be stored in memory 1090 and executed by control unit 1030, it is understood that other embodiments are possible and are contemplated. For example, message processing engine 1036 may comprise circuitry or a combination of hardware and software. For example, message processing engine 1036 may comprise a processing device executing program instructions. Further, message processing engine 1036 may be configured as an external device which may be coupled to a receiving unit. For example, such an external device may comprise an expansion module which is configured to add message processing functionality to a preexisting device.

Generally speaking, client 1012 is operable to receive and decompress signals which may include digital data. The decompressed signals may be converted into analog signals such as PAL, SECAM, or NTSC format signals for television display, or may be in digital format for use by a digital television display. As shown in Fig. 3, client 1012 includes front end circuitry 1026 operable to receive audio, video, and other data from a received signal 1070. The received signal 1070 is fed into the client 1012 at the front end 1026, which may comprise an analog to digital (A/D) converter and tuner/demodulators (not shown). Front end 1026 may select and pass a particular frequency, demodulate it, and convert analog signals to a digital format. While analog data may be converted to digital data, as noted above a received signal may comprise digital data which may require no such conversion. The digitized output may then be conveyed to a transport stage 1028 which further processes the data, conveying a portion of the data to an audio-visual (AV) stage 1034 for display and another portion to control processor 1030. In addition, CA module 1032 may receive data from transport stage 1028 and may conditionally convey a descrambled or other signal to AV stage 1034. Signaling and

control information may also be included in the broadcast along with the audio-video data and may be manipulated by software within the client 1012.

Audio-video signals and program control signals received by the client 1012 may include television programs, metadata, and menu selections accessible by a viewer through a user interface, as well as applications that may be executed. A viewer may control the client 1012 in a variety of ways, including through an infrared remote control unit, a control panel on the client, or a device that is used to choose from a menu displayed on the television screen. Selections and entries made by the viewer may be intended for one or more of several applications that are executing on the client. As mentioned above, broadcast signals 1070 are received via front end 1026 and are filtered by transport stage 1028. Unicast or multicast signals may generally be received via return channel 1038. Applications 1042 which execute on the client 1012 may arrive there in a variety of ways. For example, applications may be received via a broadcast signal 1070, via the return channel resource interface 1038, or via storage device 1018. Applications received via storage device 1018 may have been shipped originally with the client 1012 or may have been downloaded previously from another source and stored on storage 1018.

In one embodiment, client 1012 may be configured as a digital set top box for use with a satellite receiver or satellite integrated decoder/receiver that is capable of decoding MPEG video, audio, and data. For example, client 1012 may be configured to receive digital video channels that support broadband communications using Quadrature Amplitude Modulation (QAM), Quadrature Phase Shift Keying (QPSK), Coded Orthogonal Frequency Division Multiplexing (COFDM), or 8-vestigial side band (VSB), and to control channels for two-way signaling and messaging. The digital channels may carry compressed and encoded multiprogram MPEG (Motion Picture Expert Group) transport streams. Transport stage 1028 extracts the desired program from the transport stream and separates the audio, video, and data components, which are routed to devices that process the streams, such as one or more audio decoders, one or more video

decoders, and optionally to RAM (or other form of memory) or a hard drive. It is to be understood that the client 1012 and storage device 1018 (as well as any data and signals from the broadcast service provider) may be configured to accommodate analog, digital, or both analog and digital data. For storage of received analog data, conversion to digital format may be performed.

Storage device 1018 is optionally coupled to the client 1012 and may be configured to store video, audio, executable code, metadata, and other data. Storage device 1018 may be internal to client 1012 or connected externally (e.g., through an IEEE 1394-1995 connection) with either a permanent connection or a removable connection. Further, storage device 1018 may comprise any suitable type of storage, such as a hard disk drive, a recordable DVD drive, magnetic tape, optical disk, magneto-optical disk, flash memory, or solid state memory. In addition, more than one storage device such as device 1018 may be attached to the client 1012. The client 1012 and/or storage device 1018 may further be incorporated into a television set. Executable data, such as program instructions, which is stored within storage device 1018 may be retrieved and executed. In one embodiment, retrieved data may be executed or otherwise utilized in synchronization with other applications or received signals, for example corresponding to a game show, commercial, or Internet based on-line game. Alternatively, retrieved data may be executed or utilized independently, such as for video-on-demand, banking, e-mail, a web browser, or an electronic program guide (EPG).

It is to be understood that the client 1012 and system 100 described herein are intended to be exemplary only. Broadcast network system 100 and client 1012 may be different than described herein without departing from the scope of the invention. Further, various components depicted in the client 1012 of Fig. 3 may be combined, such as the placement of the integration of storage device 1018 within client 1012. Numerous alternatives are possible and are contemplated.

1. APPLICATION MODEL AND LIFE CYCLE

Generally speaking, an interactive television application may start in either a maximized state or a minimized state, depending upon how it is authored. Signaling in the directory may indicate to the system whether the application is starting in the minimized state or the maximized state. From a system's perspective, the difference between the minimized state and the maximized state is that applications which are in the minimized state may not receive a notification when a viewer presses keys. Alternatively, when in a maximized state, applications may present a filter to the system that tells the system to notify them when keys designated in the filter are pressed. While not necessarily required, an application executing in a minimized state typically reduces its usage of resources. For example, it may present an icon on the screen rather than extended graphics.

In addition to the above, an application running in either a minimized state or a maximized state may be suspended. Upon suspension, an application is not generally notified, but rather no cpu time is allocated to the application. At the termination of the suspension, an application returns to the state it was in prior to suspension. In either case, the system may invoke a function in the application to notify that application that it had been suspended so that it may take any actions necessary to ensure internal consistency.

Applications may terminate normally or may be asked by the system to terminate, for example, if a new application appears in the broadcast stream. Because an application may be in a state where termination would be disruptive to the viewer, the application may deny a request to terminate immediately. For example, a viewer may be in the middle of an online transaction to purchase an advertised product. When an application does terminate, the system is notified so that it can determine, typically working together with the network-provided control task, which application to execute next.

Transitions between states may be responses to a variety of stimuli including broadcast signaling, viewer button presses, and decisions made by the system or the

applications themselves. As noted above, the initial state of an application may be determined by broadcast signaling. A button press may be used to cause an application to move from the minimized state to the maximized state. The application itself may decide when to transition to the terminated state and when to transition to the minimized state. The system may suspend an application in order to execute another application. Further, broadcast signaling can cause the system to request that an application exit.

While the life cycle defined above may represent a default life cycle, modifications to the life cycle may be provided by calls in a network provider control task. For example, one need not even load an application until the viewer responds with an appropriate button selection in response to the presentation of an icon. Further, the above life cycle may generally correspond to a model in which only a single application is executable at a time. However, in order to support multiple applications concurrently, the application model and life cycle definition may be more complex. For example, priorities may be signaled so that the implementation may determine which applications may execute in the event that the hardware is not capable of supporting all of the signaled applications simultaneously.

Applications developed for use in interactive television systems may generally include programming code similar to that of programming languages such as C, C++, etc. However, with the proliferation of the World Wide Web (Web), and the desire to take advantage of Web and Web like resources in interactive television systems, the use of other languages such as HTML and the JavascriptTM (JS) language may be useful. However, while the use of HTML applications may be desired, the life cycle of HTML applications in an interactive television environment may be complicated by several factors.

First, HTML/JS content may be more dynamic than persistent. For example, in a current interactive television environment, an application may be configured to only execute code or use data that is packaged within the carousel in the same directory as the first program module. Hence, for security reasons the directory contents may clearly

define the application boundary and the permissions signaled within the directory may be applied to the entire contents of the directory. However, HTML/JS content may refer to other content (e.g., via a link) that is to be acquired from some location other than the carousel and the content that is referred to may replace the initial content. It is not clear that it is safe in this case to apply the same security permissions to such replacing content. Therefore, due to this dynamic nature, it is more difficult to define an “application boundary.”

Second, even when a product does not support multiple concurrent applications and restricts the application to only that content carried within the same directory in the carousel, there may be life cycle issues that affect the way that a content author designs the HTML/JS content. For example, if it is determined that the broadcaster can signal that an application may quit, it may be useful to invoke a handler written by the content author to respond to such an event. Similarly, there may be other states which might best be handled by an application-specific handler. For example, if the viewer is in the middle of a transaction involving an application, that application may wish to delay its termination until the transaction completes. Therefore, an application may be notified by the system when a broadcaster signals a new application available in the broadcast. In one embodiment, the application may be notified via an event, such as the `O_exit` event identified below. An application that determines that it does not want to exit immediately may extend its life by calling a defined event function such `preventDefault()`.

`O_exit`

```
Bubbles      : yes      -- (see DOM event model)
Cancelable   : yes
context info: the reason for exiting.
```

2. TUNING AND STREAM SELECTION

In one embodiment, two different ways for broadcast signal tuning and stream selection are provided. The first uses a markup language, such as HTML, and assumes that the content author has sufficient a priori knowledge as described below. The second uses a scripting language such as Javascript, does not assume the same a priori knowledge, and is generic enough to be applicable to stream selection from a local hard drive or VOD. Both make use of a new URL defined here known as the “broadcast:” URL. First, the URL which is used in both methods is described.

URL which can be used for tuning and stream selection

In some broadcast environments, such as MPEG based environment, it may be possible to associate a globally (or at least network) unique identifier with a broadcast stream. Use of such a unique identifier within a URL scheme may allow the unique identification of resources within that stream. A syntax of a broadcast Url scheme is provided below. Generally speaking, this scheme may provide a general mechanism for identifying broadcast resources in a manner that is network independent and platform independent. This scheme may work with digitally recorded programs as well as with live broadcasts.

The following is a formal syntax, in BNF like grammar, for a “broadcast:” URL. In the following, note that rules are separated from definitions by an equal “=”, “|” is used to designate alternatives, literals are quoted with “”, parentheses “(” and “)” are used to group elements, optional elements are enclosed in “[” and “]” brackets, and elements may be preceded with <n>* to designate n or more repetitions of the following element where n defaults to 0.

broadcast_url	= broadcast_scheme “:” [broadcast_hier_part]
broadcast_scheme	= “broadcast”
broadcast_hier_part	= broadcast_net_path broadcast_abs_path
broadcast_net_path	= “//” service_address [component_list] [broadcast_abs_path]

service_address	= channel_name "current"
channel_name	= *(domainlabel ".") toplabel
domainlabel	= alphanum alphanum *(alphanum "-") alphanum
toplabel	= alpha alpha *(alphanum "-") alphanum
alphanum	(may be as defined in RFC 2396)
alpha	(may be as defined in RFC 2396)
component_list	= "," component *("," component)
component	= stream_selector
stream_selector	= stream_type "=" stream_id
stream_type	= "video" "audio" "data" "subtitle" "teletext"
stream_id	= 1*alphanum "default" "current" "none"
broadcast_abs_path	= "/" path_segments
path_segments	(may be as defined in RFC 2396)

Given the above definition, one example of a summary of usage may be represented:

broadcast : { //<service_address>{ ;<component_list> }

Where *service_address* is defined as follows:

service_address ::= *channel_name* | current

where:

channel_name specifies a DNS-style name that uniquely identifies the channel.

current specifies the service currently selected.

The *component_list* is a comma-separated list identifying specific components in the stream and may be defined as follows:

```

component_list ::= component *( “,” component )
component ::= stream_type “=” ( track_tag | “default” ) |
stream_type ::= “video” | “audio” | ...

```

A *track_tag* may be defined as an ASCII string of arbitrary length, typically between 1 and 4 bytes. A *track_tag* of “0” is equivalent to the default component of the specified stream type. For example, the URL “broadcast://tf1.fr; video=0, audio=eng” identifies the default video stream and the English audio stream on the channel named “tf1.fr”.

A/V MIME Types Associated With The Broadcast: Url

While the following discussion primarily describes the semantics associated with video and audio stream types, other stream types are permitted within the URL and are discussed in the section entitled “Obtaining Applications and Data” below. In either case, in one embodiment, , the following events may be dispatched during a service selection.

Stream Selection Events

- Click** The selection occurred as a result of a click event. Default action is to request the specified service. Note that this event is generally a user-input event.
- Load** If the request succeeds, a load event will be dispatched. Normally such an event is dispatched after the URL is finished loading, but indefinite video and audio streams would never finish loading. Hence, it is appropriate to dispense this event once processing of the requested audio and video

streams has been successfully initiated through all of the hardware involved in the processing pipe.

- Error** If the request is denied or otherwise invalid an error event is dispatched.
- Abort** If the user aborts the request before the load event is dispatched, an abort event is dispatched.
- Unload** If the request replaces an existing target an unload event is dispatched.

When no component list is specified, the MIME type corresponding to the broadcast: URL may be application/mpeg.service and this type may correspond to a service as defined an MPEG standard. Hence, such a MIME type would contain not only video, audio, and subtitles, but also the data that is multiplexed on the same service with them, e.g., html and/or other applications.

When a video component is specified, the MIME type corresponding to the broadcast: URL is video/mpeg. Similarly, when an audio component is specified, the MIME type corresponding to the broadcast: URL is audio/mpeg.

As shown in the examples below, it is possible to refer to multiple elementary streams in a single URL. If the streams referred to include only a single video stream and a single audio stream which is synchronized with that video stream, then the resulting streams will be considered to be of type video/mpeg; otherwise, the type of the multiple streams will be type application/mpeg.service.

Examples

This section explains the meaning of several example URLs, which, in some cases, if used as in the complete example shown in the next section, could result in tuning and/or stream selection.

`broadcast :`

Identifies the currently tuned service_address and component_list for the *primary pipe* (see *JS Tuning and Stream Selection below*). This usage is similar to “tv:” in the DASE specification and “dvb://current.av” in the MHP specification. So, for example, this may be used within an HTML element to re-size and re-locate the currently playing video.

`broadcast ://cnn.com`

Identifies the CNN TV channel and all of its component streams. This form of the URL can be used to request that the TV tuner switch channels. This URL in a service selection context causes the automatic selection of the default streams. That is, when used in a service selection context, the user-agent will (if the application is appropriately authorized) tune to the new channel and automatically select the default video stream, select the default audio stream (based on the preferred language), select the default sub-titles and teletext if identified in the user’s current preferences, and select the default data carousel.

`broadcast ://cnn.com;audio=eng`

Identifies the CNN TV channel and explicitly selects only the English audio stream. Documents use this form of the URL to explicitly reference a specific elementary stream.

`broadcast ://current;audio=eng,video=current`

Selects the English audio stream on the current service. This URL allows the author to switch the current audio stream without explicitly knowing the current service address, and without changing the currently selected video stream.

2.1 HTML Tuning and Stream Selection

When the content author has knowledge of the DNS name that corresponds to a given channel, they may use HTML to cause tuning to that channel. For example, the following HTML allows the HTML document to present a link, “my_link”, which requests the tuner to select a new service.

```
<A ID="my_link" HREF="broadcast://cnn.com">Click Me</A>
```

If the request is authorized and resolves to a valid channel_name, then the HTML document will be unloaded and replaced with a TV media handler playing the default video and audio streams associated with the cnn.com service.

In one embodiment, HTML applications may permit the use of URLs that reference MPEG video or audio streams or MPEG-2 services as illustrated in the following HTML elements and CSS attributes. If use of the URLs result in component selection from the currently tuned service, only the Load, Error, or Abort events could occur.

Attribute	HTML element		
	video/mpeg	audio/mpeg	application/mpeg.service
background-image	yes		yes
background-video	yes		yes

a.href	yes	yes	yes
img.src	yes	yes	yes
input.src	yes	yes	yes
object.data	yes	yes	yes

In Addition, URLs may cause service selection when referenced via the location object in a scripting document object model as described below or when used as a parameter in a “goto” dialog.

2.2 JavaScript Tuning and Stream Selection

A second way to enable signal tuning and stream selection utilizes a scripting language such as JavaScript to allow the content developer to explicitly control virtual pipes that exist between sources of audio and video (e.g., tuner, local hard drive) and their destinations (e.g., screen, local hard drive). This section describes how a JavaScript programmer can exert fine-grained control over not only which streams are chosen for display, but also which streams may be recorded onto a hard drive and the speed and direction with which recorded streams are displayed.

An abstraction, known as a pipe, may be used used to embody the association between the source of a stream (e.g., a tuner or a file containing a recording on a hard drive) and the ultimate destination (e.g., the display or a file on the hard drive), including, for example, any resources that are required between the source and destination (e.g., Conditional Access hardware, I/O buffers).

When receiver software boots up, a set (or array) of pipes may be defined. In one embodiment, this array of pipes represents all of the possible connections between stream sources and destinations that may be represented on a particular hardware platform. Other embodiments may represent fewer than all possible connections. Because these are abstractions, it is possible to have a defined pipe without having all of the hardware which is required by the pipe currently allocated to that particular pipe. A defined pipe where less than all of the hardware has been allocated to it is said to be in an “unrealized” state. A pipe is “realized” when all required hardware has been allocated to that pipe.

The programmer may use the defined pipes array to:

- select a pipe
- set the source of a pipe
- set the destination of a pipe if it is a file
- control the speed of a pipe, if the source is thus controllable, and also be able to set the location when such is possible
- select the components of a stream that will be sent to the destination
- add or remove event listeners
- and request that a new pipe be started for recording purposes.

In addition, the programmer may determine which pipe is being used for a given image by using the *id* which is associated with that image. For example, if there is an HTML snippet included that states

```

```

then, the JS programmer may refer to *foo.pipe* and invoke any of the methods which are described below and may read/write the values in the attributes as permitted by the definition below.

The Pipes Collection And The Tvpipes Object

Object Model Reference:

```
[window].navigator.tv.pipes[i]
[window].navigator.tv.pipes.primary
```

The pipes array above is a collection of TvPipe objects as described below. The primary object is a reference to a pipe object that can be settable or gettable in javascript. The TvPipe object has the following properties, methods, and collections.

The TVPipe Object

Properties:

name	String that identifies this pipe in the pipes[] array. (Read-only)
src	URL corresponding to the current channel (read/write) -- may correspond to either a file: or broadcast: url
realized	“true” “false” (read-only)
status	“connected” “connecting” “disconnected” “disconnecting” -- (read-only)
destination	only if pipe is currently being used for recording (read/write) -- url corresponding to file:
type	“record” “display” (read-only)

position unsigned int (read-write)
 -- # of ms into the event

speed int (read-write)
 -- 100 is normal speed
 -- 0 is still
 -- 500 is 5 times normal speed
 -- -100 is normal speed, backwards
 -- -500 is 5 times normal speed, backwards
 -- 50 is half speed, forwards, etc.

event_info name-value pairs about the current event (read-only)

Collections:

Components[] array of component objects (see **TvComponent** below)
 indicating those which are currently selected

Methods:

record(uri) Starts the recording to the file named in the uri if sufficient
 resources exist.

addEventListener()

removeEventListener()

dispatchEvent()

The TvComponent object

A TvComponent object represents a data stream which may be carrying video, audio, interactive data, subtitles, or other content types.

Object Model Reference:

```
[window].navigator.tv.pipes[i].components[i]
```

Properties:

name	String that represents the name (i.e., the value of the track_tag) of the component (read-only)
selected	“true” “false” (read/write) -- boolean indicating that this component has been selected
type	“audio” ”video” ”data” ”subtitles” ”teletext” ... (read-only)

3. CONTROLLING THE DISPLAY AND PLAYING OF VIDEO, GRAPHICS, AND AUDIO IN HTML/JS

This section describes how graphics may be positioned and sized on top of video, how the video itself can be positioned and sized, and how the audio can be controlled. Transparency between the graphics plane and the video plane, palette-based color, and the MPEG I-Frame are discussed here as well.

In one embodiment, a receiver may be configured to support multiple graphics and video layers. In such an embodiment, there may be a bottommost layer that is used to display video and an interactive layer (OSD) on top of that which is used to display

text and graphics. Rendering of video, both stills (e.g., I-frames) and in-motion video, may be supported by a hardware MPEG decoder.

In addition to the above, an extension may support a layer on top of the OSD layer called the subtitle layer. A further extension may be used to support a multi-plane graphics layer. In one embodiment, this layer may lie logically between the bottommost layer and the interactive layer. This multi-plane graphics layer may be used to display still pictures such as JPEG, MPEG, or other images. Included below is a discussion of support for images in the multi-plane graphics layer.

3.1 Color and transparency

Various models exist for specifying how color information is represented. For example, a “color space” is a model for representing color in terms of intensity values. Examples of color spaces include RGB which is commonly used for computer displays, CMYK which is used for color printers, and YUV which is traditionally used for television.

The number of bits used to define a pixel's color may be referred to as its bit-depth. True color, sometimes referred to as 24-bit color, is the specification of the color of a pixel on a display screen using a 24-bit value. By using 24-bits to specify color, up to 16,777,216 colors are possible. Display systems vary in their ability to support color. For example, some color display systems offer a 32-bit color mode. In a 32-bit color display system, the extra byte, called the alpha channel, may be used for control and special effects information.

Because lower end set-top boxes may not have sufficient memory to support true color, palette-based models may be used. With a palette based model, the color of a pixel is represented by an index into a color palette. In such a model, content authors may define their own color palettes containing colors of their own choosing. The actual colors

in a palette are typically represented as 48-bit numbers with the first three of those numbers representing the actual color and the fourth of the numbers representing the amount of transparency in the color.

In a system where there is sufficient memory to support true color, multiple applications can share the screen with little or no problem because the fixed color palette is large enough to accommodate the multiple different hues required by each application. However, in a system where the number of colors supportable is limited, if multiple applications sharing the screen declare their own color palette, the viewer experience can be disturbing.

Often devices where graphics overlay video (such as less expensive set-top boxes) have palettes with limited built-in transparency models. Two common models where transparency is limited include the following:

- a. Only a single non-opaque element in the palette is supported. For example, that element could be completely transparent, or it could be pink that is 50% transparent, etc. In either case all other elements must be opaque.
- b. A single element in the palette that can be an semi-transparent or completely transparent is supported. All other elements in the palette can be either completely opaque or have a particular, fixed amount of transparency. For example, a palette that can hold n colors could contain a single color that is 30% transparent, m ($m > 1$) colors that are 50% transparent – in this case the remaining $n-(m+1)$ colors must be either 50% transparent or completely opaque. In other words, there cannot be 3 non-opaque colors in a palette all having a different level of transparency.

In order to maximize the availability of the transparency values for the author's use, a system may be defined that allows an author to specify a region, including both its location and dimensions, which they want to contain overlay graphics. Were the author

not able to specify this region, they would have to “waste” (the) one transparent color by painting the area outside of the graphics region with the (sometimes only) transparent color available in the palette. (This also reduces the amount of space required to store the On-screen display graphics.) Subsequently, the an application may be configured to dynamically change its region (even when that application is transcoded prior to broadcasting).

Fixed-Variable Palette

In one embodiment, a combination fixed-variable palette may be used where the variable components are specified by the application. The first m of n colors may be chosen to be fixed with the 0th color being fully transparent. For example, in a 256 color palette where there are 8 bits available for color, the first 188 colors may be as specified in an existing or proposed standard, such as the DVB MHP color palette. The remaining 68 colors may be taken from colors specified by the color palette accompanying the image. In one embodiment, these 68 colors may be selected from the first 68 colors specified in the image palette. Therefore, an application content designer should ensure that the most important colors are placed first in the palette.

If it is necessary to support multiple applications, each of which brings its own color palette, then the system may choose to place into the palette a mixture of the first colors in each of the application/image specific palettes. Similarly, any time it is expected that multiple images will be sharing the screen, the author of those applications may get best results by using only the fixed colors in one of the images or the same palette for both of the images.

Transparency between the graphics and video plane may be important in interactive television, as the viewer often wants to be able to see the video that is running under the interactive text or images. In one embodiment, the Porter-Duff SRC composition rules may be used for composing graphics with each other. Generally, the

underlying video is opaque, hence the video shows through the graphics when they are transparent. The Porter-Duff SRC rule is relatively easy to compute because the transparency of one object over the top of another chooses the alpha (transparency) value of the object on top as the transparency of the composed objects. While in some cases this result may appear somewhat un-natural looking, graphic artists are accustomed to planning their layout with this rule in mind.

Because it may be computationally complex to compute the resulting alpha value, set-top boxes may be permitted to approximate the SRC-Over rule using the SRC rule (unless the object on top is completely transparent, in which case, the pixel values for the transparent object should not be applied). In one embodiment, HTML applications may specify a particular default composition rule, such as SRC-Over. However, in those cases in which a set-top box does not have sufficient computational power to compute the SRC-Over composition, an approximation of the SRC-Over rule may be used (e.g., using the Porter-Duff SRC rule.)

3.1.1 The clut property

The palette format discussed below allows images whose colors are specified using an index into a palette to also specify per-pixel transparency values through the use of an alpha channel. However, for other images, backgrounds, etc., another method may be required for specifying the transparency. Therefore, new properties which allow the specification of these alpha values is described in the subsection below entitled “Alpha Properties.”

An application author may specify that a particular palette (often referred to as a color lookup table or “clut” for short) may be useful in rendering objects in the body of an HTML page. This palette could be used in one of several ways. For example, in a vertical network the author may specify both a palette and the colors of objects using only that palette because they know that all receivers have similar color capabilities.

Alternatively, when the author expects that their application may be used in a network that includes receivers of varying capabilities, this palette may serve as a hint as to the best colors to use. In either case the author may specify a color palette by using the ‘clut’ property documented below.

‘clut’

Value	: <url> none
Initial	: selected default
Applies to	: body
Inherited	: yes
Percentage Values	: N/A
Media type	: tv

The <url> value above may be used to identify the location of the actual palette. If no <url> value is specified, or there is no ‘clut’ property in the style sheet or inline, a default palette may be used.

In the table which follows, one embodiment of a palette format is presented. In one embodiment, the MIME type associated with a url that contains a palette in the format defined by the table below may be “application/clut,” with an extension of “.clt”. In addition, user agents and HTML applications may accept cluts in the format used by “png” images. The types of these cluts may be the same as entire png images.

Usage example (using inline style):

```
<BODY style="http://cnn.com/demoClut.clt">
```

Format of palettes of type application/clut:

	No. of bits	Identifier	Notes
PaletteResource() {			
color_model	8	uimsbf	The value of 1 for the color model may be used to indicate RGB, whereas the value 2 is used to indicate YUV.
nb_colors	16	uimsbf	The value in nb_colors is the number of colors in the palette.
first_color	8	uimsbf	The purpose of the first_color value is to allow multiple resources, each specifying their own palette, to share the color space.
for (i=0; i<n; i++) {			The first, second, and third amounts (amt_first, etc.) refer to the amount of RGB or YUV, depending upon the value of color_model. The value in alpha (amt_transparency) represents transparency with 0 being transparent and 255 being opaque.
amt_first	8	uimsbf	
amt_second	8	uimsbf	
amt_third	8	uimsbf	
amt_transparency	8	uimsbf	
}			

}			
---	--	--	--

3.1.2 Alpha Properties

Use of an application-specific palette allows an author to specify the alpha channel corresponding to a particular index. Below is one embodiment illustrating how alpha properties may be specified.

'alpha'

Value	:	<hexadecimal-integer> <percentage> <normalized-number>
Initial	:	#FF
Applies to	:	All elements
Inherited	:	yes
Percentage Values	:	percent opacity
Media type	:	tv

Usage example:

```
<EM color=#008080 style="alpha:#C0">
```

In one embodiment, the value #FF is fully opaque and the value #00 is fully transparent. The normalized-number may range between 0.0 (fully transparent) and 1.0 (fully opaque). Similarly, 0% may indicate full transparency and 100% fully opaque. These same terms may be used with similar meanings in the additional properties illustrated below.

‘background-alpha’

Value: <hexadecimal-integer> | <percentage> |
 <normalized-number>

Initial: #FF
Applies to: All elements
Inherited: no
Percentage Values: percent opacity
Media type: tv

Usage example:

<BODY style="background: black; background-alpha:#00">

‘border-alpha’

Value: <hexadecimal-integer> | <percentage> |
 <normalized-number>

Initial: #FF
Applies to: All elements
Inherited: no
Percentage Values: percent opacity
Media type: tv

‘border-top-alpha’

Value: <hexadecimal-integer> | <percentage> |
 <normalized-number>

Initial: #FF
 Applies to: All elements
 Inherited: no
 Percentage Values: percent opacity
 Media type: tv

‘border-bottom-alpha’

Value: <hexadecimal-integer> | <percentage> |
 <normalized-number>

Initial: #FF
 Applies to: All elements
 Inherited: no
 Percentage Values: percent opacity
 Media type: tv

‘border-left-alpha’

Value: <hexadecimal-integer> | <percentage> |
 <normalized-number>

Initial: #FF
 Applies to: All elements
 Inherited: no
 Percentage Values: percent opacity
 Media type: tv

'border-right-alpha'

Value: <hexadecimal-integer> | <percentage> |
<normalized-number>

Initial: #FF
 Applies to: All elements
 Inherited: no
 Percentage Values: percent opacity
 Media type: tv

'outline-alpha'

Value: <hexadecimal-integer> | <percentage> |
<normalized-number>

Initial: #FF
 Applies to: All elements
 Inherited: no
 Percentage Values: percent opacity
 Media type: tv

3.2 Positioning of Graphics on top of Video

An HTML developer may use Cascading Style Sheets (CSS) to specify relative or absolute positioning of graphics on top of video. Additionally, CSS may be used to specify other characteristics as well, such as a border, associated with the visual appearance of a graphic or text block.

In one embodiment, the size of the OSD may be defined as the size of the block (div) whose name has been defined to be "osd." If there are no such blocks, the size may be the size of the first division in a top level window. Where a set-top box cannot create an OSD of exactly that size, the closest available size to the specified size may be used. The examples below illustrate how graphics may be positioned relative to background video. The resulting display for each of the examples is the same, given the assumptions stated below in the descriptions.

In this first example, the background is set to a broadcast video via a url by using a background-image attribute. In this case it is assumed that the application has been granted the tuning privilege and therefore the tuner is tuned to the station carrying the Family-Videos network and the default video and audio is displayed.

First Example of Positioning images on top of video

```
<html>
<head>
<title>example</title>
</head>
<body style="background-image: url(broadcast://family-videos.com)>
<div style="position: absolute; left: 200px; top: 80px; color=gray; border: thin
solid red">
<div style="position: absolute; left: 10px; top: 10px; font-size=18pt;
    line-height=120%; color=yellow; border: thin solid yellow;
    background-alpha: #01; compose-rule: src">
<p>Nicolas a 18 mois
</div>

</div>
```

```
</body>
</html>
```

In the second example, it is assumed that the television has already been tuned to the Family-Videos network.

Second Example of Positioning images on top of video

```
<html>
<head>
<title>example</title>
</head>
<body style="background-image: url(broadcast://current); ">
<div style="position: absolute; left: 200px; top: 80px; color=gray; border: thin
solid red">
<div style="position: absolute; left: 10px; top: 10px; font-size=18pt; line-
height=120%; color=yellow; border: thin solid yellow;
background-alpha: #01; compose-rule: src">
<p>Nicolas a 18 mois
</div>

</div>
</body>
</html>
```

In the third example, it is once again assumed that the television has already been tuned to the Family-Videos network and a transparent color for the background is explicitly selected (though this would be the default anyway).

Third Example of Positioning images on top of video

```

<html>
<head>
<title>example</title>
</head>
<body style=" background-color: transparent">
<div style="position: absolute; left: 200px; top: 80px; color=gray; border: thin
    solid red">
<div style="position: absolute; left: 10px; top: 10px; font-size=18pt;
    line-height=120%; color=yellow; border: thin solid yellow;
    background-alpha: #01; compose-rule: src">
<p>Nicolas a 18 mois
</div>

</div>
</body>
</html>

```

The fourth example shows that the background need not be specified at all, assuming again that the television has already been tuned to the Family-Videos network.

Fourth Example of Positioning images on top of video

```

<html>
<head>
<title>example</title>
</head>
<div style="position: absolute; left: 200px; top: 80px; color=gray; border: thin
    solid red">

```

```

<div style="position: absolute; left: 10px; top: 10px; font-size=18pt;
        line-height=120%; color=yellow; border: thin solid yellow;
        background-alpha: #01; compose-rule: src">
<p>Nicolas a 18 mois
</div>

</div>
</body>
</html>

```

Some set-top boxes may lack the resources to to simultaneously play video and display a full OSD at the same time. Therefore, to account for this possibility, an HTML application on one of these boxes may not attempt to interpret any content on those boxes unless a META element, as shown below, is used to indicate that the content was designed specifically for these boxes.

Header meta-data:

```
<META name="tv-use" content="full-screen">
```

3.3 When To Render Graphics

When rendering graphics as they are downloaded, it sometimes makes sense to delay displaying to the viewer until at least a subset of the resources, which have been deemed as essential by the content creator, have been downloaded. In one embodiment, a content creator may label the essential subset of resources by identifying them using a directive such as a “prerequisite” meta-data header. For example, the following indicates that no rendering for the page may occur prior to acquiring “background.mpg”

<META name="prerequisite" content="http://www.cnn.com/background.mpg">

In addition to indicating that certain resources may be required prior to rendering, a content author may further control the rendering through the use of a render-policy and/or render-timeout properties as described below.

render-policy: progressive | layoutComplete | loadComplete

Applies to: Body

Initial: progressive

Inherited: no

Percentage: N/A

The progressive rendering policy indicates that displaying can start as soon as the essential resources (those marked as prerequisites in meta-data headers) have been acquired. With this policy, as resources are acquired, they are incorporated into the rendered and displayed graphics.

The layoutComplete rendering policy indicates that the rendered image may not be displayed until the software has acquired sufficient information to determine the complete on-screen layout and has acquired those resources labeled as prerequisites. This policy prevents objects from appearing to move around as the rendered graphics incrementally appear onscreen.

The loadComplete rendering policy indicates that the graphics may not be displayed until all resources that will be used for rendering the display have been downloaded. The only difference between the loadComplete rendering policy and labeling all resources as prerequisites, is that in the first case the OnLoad event will have been delivered to the appropriate handler, if any, prior to rendering, and hence may affect the rendered view.

In certain circumstances the specified rendering policy may not be possible, i.e., if a prerequisite resource has been removed from the carousel and acquisition via a modem has been denied by the viewer. In one embodiment, if no timeout for this loading has been specified, then the timeout may default to an indicated value (15s) as shown in the render-timeout property below. If a timeout occurs, and at least all of the prerequisite resources have been acquired, what is available for the new page may be displayed, independent of the specified rendering policy. If some of the prerequisite resources have not been acquired, then it may be preferable, if possible, for the display to show the previous page, if any. If this is not possible, then either an error message may appear or the box may render and display those resources which it has been able to acquire.

render-timeout	none <time>
Initial	15s

In any case, while the box is acquiring the resources for the new page, it may be preferable to continue to display the old page, and, if possible, allow the viewer to interact with the old page.

Scene transitions

In one embodiment, all user agents may be required to comply with the following two requirements:

- if the element which contains the video neither moves nor changes size during a transition from one page to another, there will be no video glitch; and
- if the size or location of an element containing video does change during a transition from one page to another, the changes in video and graphics will be closely synchronized with one another.

3.4 Video positioning and resizing

In addition to considering video as being a virtual underlying plane, the content author may place video boxes within html content by using “broadcast:” as the “src”, or as the source of “data” of an HTML element, for which location and/or size are specified. In particular, the location can be specified through the use of CSS.

The examples below demonstrate how a “broadcast:” url may be used in an IMG or OBJECT element to request a particular scaling size.

```
<IMG height=300 width=400 style="position:absolute; left:200px; top:80px"  
      src="broadcast://current ">
```

```
<OBJECT height=300 width=400 data="broadcast://current  
      "></OBJECT>
```

Both of the examples above request that the currently tuned channel (identified by the url, “broadcast:”) be scaled to the size of 300 by 400. The first example also demonstrates how CSS properties can be used to position the resulting video box. Although the actual size and position of the video may be partly determined by the capabilities of both the set-top box and the drivers supplied for given hardware, applications should attempt to position and scale the video as specified by the content author.

3.5 Support for MPEG stills

HTML applications may also support the displaying of still images, such as MPEG I-Frames, in either the video plane or in the multi-plane graphics layer. Because set-top boxes frequently have special purpose hardware for efficient rendering of MPEG, MPEG images are particularly appropriate for the television environment. MPEG I-frames may be recognized by the MIME type of image/mpeg and will have an extension of mpg.

The following example demonstrates the use of an MPEG I-Frame.

```
<html>
<head>
<title>example</title>
</head>
  <body style="background-image:url(http://pepsi.com/pepsi-
  ad.mpg)" >
</body>
</html>
```

3.6 Control of Audio

This section deals with playing of audio from memory and controlling the audio stream after it has been selected. The CSS aural properties can be used to control the audio stream and audio being played from memory. Aural style sheets allow content developers to control the volume, allow the presentation of audio icons (cues), and even allow the developer to control spatial properties and mixing. These style sheets may further support the volume properties, the pause properties, and the mixing properties. HTML itself provides a way to specify an audio element using the <object> tag. There are currently a few events defined on this element: onlayoutcomplete, onmouseenter, onmouseleave, onreadystatechange.

Although CSS provides a way to support volume control, a Javascript object may be used to implement ‘mute.’ The reason for this requirement is that the object needs to remember the previous volume setting, so that when the sound is turned back on, it will immediately be set back to the volume to which it was set prior to muting.

4. OBTAINING NON-AV RESOURCES

Applications and data may be obtained from sources including broadcast or point-to-point (e.g., over a return channel via modem). In one embodiment, HTML applications may provide access to broadcast resources via the broadcast: URL protocol, as well as those that are carried within a broadcast http: protocol (bhttp). Access via the broadcast: protocol is as described above. For the bhttp protocol, whose client-side behavior is as described below, the client side treats the broadcast stream as a cache.

4.1 Access to Broadcast Resources

4.1.1 Access via the broadcast: URL Protocol

The HTML/JS content developer may access non-AV broadcast resources using the broadcast: protocol in a way that is similar to the way they use the broadcast: protocol to access AV resources.

An Informal Description of the Scheme for non-AV resources

The description here differs from that provided in the previous section in that path_segments have been added to allow specification of particular data streams.

```
broadcast : { //<service_address>{ ;<component_list> } } { /<path_segments> }
```

A *service_address* is defined as follows:

service_address ::= *channel_name* | *current*

where:

channel_name specifies a DNS-style name that uniquely identifies the channel,
and

current specifies the service currently selected.

As stated in the previous section, the *component_list* is a comma-separated list selecting specific components in the stream. The *component_list* is defined as follows:

component_list ::= *component* *(“,” *component*)

component ::= *stream_type* “=” (*track_tag* | “default” | “current” | “none”)

stream_type ::= “video” | “audio” | “data” | “subtitle” | “teletext”

The presence of *path_segments* in a URL indicates that it references a specific module in the data carousel associated with the *service_address*. For example, the URL “broadcast://tfl.fr/background.png” refers to the background.png module on the default data carousel.

Examples

broadcast:/background.png

Load the module background.png from the default data carousel on the current service.

broadcast://current;data=htp0/

Select the data carousel with track_tag “htp0”, examine the directory module and load the “default” module in that directory (e.g., index.htm).

Some applications may require the ability to load a specific module within a data carousel. For example, the following HTML loads the background.png module from the default carousel and uses it as a background image.

```
<BODY background=”broadcast:/background.png”>
```

During a carousel request, typical HTML events which may be dispatched include.

Load If the request succeeded, a load event is dispatched after the URL is finished loading.

Error If the request is denied or otherwise invalid an error event is dispatched.

Abort If the user aborts the request before it complete, an abort event is dispatched.

Resident applications (such as a control task, or EPG) may require the ability to automatically launch an application during service selection. In these instances a URL of the form

```
broadcast://cnn.com; data=htp0/
```

informs a browser to automatically execute the default module on a specific data carousel.

Note: The default module may be selected by checking the specified directory for the following modules. The first module name that exists is automatically loaded.

BHTTP
Index.htm
Index.htm

A simpler URL of the form “broadcast:” informs the browser to automatically execute the default module in the default carousel of the currently selected service.

4.1.2 Access Via the Http: URL Scheme and the broadcast carousel

In one embodiment, HTML pages may use “http:” URLs to load resources from the carousel. In particular, the HTTP cache may be enhanced to automatically cache HTTP entities from the data carousel. Therefore, the http: URL handler will be able to load HTTP entities directly from the HTTP cache without opening an HTTP connection to the origin server. Hence, HTML pages that use an “http:” URL to reference HTTP entities may not notice any difference between resources retrieved from the broadcast and those retrieved using the client/server HTTP URL protocol.

One embodiment of such a model is illustrated in Fig. 4. In the example of Fig. 4, the Head End 402 is acting as a proxy, is responsible for fetching data from the Origin Server 410 which has been requested by the carousel manager 420 (through as many hops as needed), and for placing the proper cache headers according to HTTP syntax and semantics (based upon expires header). The set-top-box 404 may then populate its cache from the carousel. The Expires entity-header field may give the date/time after which the response is considered stale.

In response to detecting an http url, the client-side may first check its local cache. If the requested data is not found in the cache, the client may check the current carousel if any, possibly retrieving data from the carousel. Alternatively, it may send an HTTP request for the specified URL.

In order to allow proper cache behavior, the carousel may provide expiration dates and other cache control information in HTTP headers. For example, such information may include:

1. Cache-Control (HTTP 1.1) header information that specifies the maximum amount of time that a particular page may be considered to be fresh.
2. In a response to either the head-end or the client, the origin server may add the following headers in order to allow efficient and accurate caching:
 - expires, indicating the data/time after which the page may be considered stale;
 - last-modified, indicating the last time the data was modified at the origin server;
 - and
 - ETag (HTTP 1.1) data, for use with conditional requests, that provides a value indicative of the current page (e.g., some generation number or checksum).
3. Conditional get requests that require the set-top-box to verify either the last-modified value or the ETag value will result in an appropriate request to the origin server, which may return the Not Modified status code if the data is still valid. However, the set-top box may be configured to “believe” the expiration time provided in a header. Note that the server-side may modify the actual expiration time from the value to which it was set by the Origin Server.

It is noted that since network congestion can delay a response, revalidation of data which becomes obsolete during transit could result in an infinite loop. Consequently,

HTTP 1.1 specifies that a response may not be revalidated in order to avoid infinite loops. This rule may be followed whether the data comes from the carousel or directly from the origin server.

4.1.3 Relative URLs

The use of relative URLs, which specify neither “http:” nor “broadcast:”, may work with either protocol. In one embodiment, relative URLs may be automatically translated to one containing the same prefix that was used to obtain the page which contained the reference. Therefore, if a page was obtained using the “broadcast:” URL, then all relative references within that page may also be obtained using the “broadcast:” URL. Because it is possible that initial pages of an application may be downloaded via “broadcast:”, it is possible to author applications which never explicitly specify either “broadcast:” or “http:” yet will perform correctly.

4.2 Modem Control

In Europe, and elsewhere, local communications are still expensive and it might be necessary to warn the user and perhaps display the communication price. While it may be up to the system to actually open and close connections, it may be useful for the application to notify the system when it is finished with a system. Also, in many networks, it is common for different applications to require connections to different phone numbers, rather than to a single phone number associated with a particular Internet Service Provider (ISP). In such systems it is common for the different numbers to be associated with a single modem bank with the different numbers being used for accounting and other information. Hence, the HTML/JS application needs to notify the system when it finishes using a connection and needs to be able to request a connection,

providing appropriate parameters. Therefore, various embodiments may support the following methods on the navigator.modem object.

`navigator.modem.disconnect()`

-- indicates to the system that the application has finished using the connection. There may be no events associated with completion.

If an application invokes the following method:

`navigator.modem.connect(string parameter, int ms_timeout),`

the string parameter could contain, for example, a phone number to which the system may connect. The `ms_timeout` parameter may be used to indicate how long (e.g., in milliseconds) the system may try to connect. The 'modem' object may be configured to provide the connection status as a read-only property.

The system may automatically generate connection events when something happens on the modem. Examples of such connection events include: success, failure, and `disconnect_occurred`.

4.3 Caching Hints – Pre-Requisite, Link, and Prefetch

There are at least two important clues that may be present within an HTML application to aid the HTML/JS client-side application in determining which resources have higher caching priority. The two clues are represented by the pre-requisite meta data in the header and the link style which is used to indicate which pages, though not needed immediately, may soon be requested by the application.

Pre-Requisite Meta header

As explained above and illustrated below, all resources which are labeled as a pre-requisite must generally be available prior to rendering the corresponding page for presentation.

```
<META name="prerequisite" content="http://www.cnn.com/background.mpg">
```

Consequently, pre-requisite resources may be identified and given a higher priority for caching.

Using the Link data for pre-fetching

In addition to the above, a link element, which may appear in the <head> portion of a page, indicates resources that may be desired by the viewer of the current page. Therefore, resources listed in this element are also good candidates for pre-fetching into the cache.

However, certain caveats must be observed. For example, if a CSS document is listed in the link element, it is possible that it may be applied to the current document rather than to a document which would be cached for later use. In order to avoid such a possibility, a new value, prefetch, is introduced for the rel attribute. If a resource is indicated in a link statement in the head, and it is identified as having a prefetch relationship, then the set-top box may determine that it is a good candidate for caching.

```
<link rel="prefetch">
```

4.4 An Event that indicates that a URL was updated

One of the advantages of interactive television is that the viewer's presentation can be updated in real-time. For example, if there is a new goal scored on a soccer game,

the viewer may want to receive an update even though they are watching a movie. Such an update can be broadcast by changing the content corresponding to a URL. This section describes how applications can be notified when the content corresponding to a URL changes, using a URLEvent.

The target of a URLEvent generated by the user agent is determined by the user agent according to the following rules:

1. If the URL whose status has changed is identified as the attribute's value of the corresponding node type as listed in the table below, then the URLEvent is delivered by the user agent to the corresponding node.
2. If the URL whose status has changed is the url for the page itself, then the URLEvent will be delivered to the body.

Attribute	Corresponding Node
background	Body
src	Image
data	Object
href	Link
src	Input
src	Frame
src	IFrame

Attributes

url of type DOMString, readonly

Identifies the URL from which the event was generated.

Methods

initUrLEvent

The `initUrLEvent` method is used to initialize the value of a `UrLEvent` created through the `DocumentEvent` interface.

Parameters

`typeArg` of type `DOMString`

Specifies the event type.

`canBubbleArg` of type `boolean`

Specifies whether or not the event can bubble.

`cancelableArg` of type `boolean`

Specifies whether or not the event's default action can be prevented.

`urlArg` of type `DOMString`

Specifies the Event's url.

The different types of `UrLEvents` that can occur are:

URLInserted

The `URLInserted` event occurs when a URL is added to the carousel.

Bubbles: Yes, Cancelable: No, Context Info: url

URLUpdated

The `URLUpdated` event occurs when a new version of an URL is created on the carousel.

Bubbles: Yes, Cancelable: Yes, Context Info: url

URLRemoved

The `URLRemoved` event occurs when a URL is removed from the data carousel.

Bubbles: Yes, Cancelable: No, Context Info: url

The default action in the case of `URLUpdated` (which can be cancelled by calling `preventDefault()`) is to reload the content of the associated url). There is no default action for `URLInserted` or `URLRemoved`.

Also, note, that it is guaranteed that the events will be delivered in a top-down order; hence, if the body changes, then the event representing the update of the url associated with the body will be delivered prior to delivering any events concerning urls referred to by the body.

Note that the above event can be signaled in the carousel by carrying a delta directory that indicates differences between the last directory and the current directory. That way, an implementation need not download the entire content before it knows whether the app is going to use it or not – it need only find out that there's a new version available.

The Cache Object

Introduction to dynamic cache hints

Since typically the amount of information that can be presented on a television screen is substantially less than contained in a page that is typically viewed on a PC, an author creating content for television will most often spread the same amount of information over multiple pages. Hence, the viewer will typically “scroll” between pages, and their navigation through a page can be a good indicator of which resources will be needed next. An author making use of such information by conveying hints based upon this navigation to the user agent can enable much better performance on lower end clients.

A Host Cache Interface

The cache interface supports two methods, `prefetch` and `remove`. The `prefetch` method specifies both the URL associated with the resource to be prefetched as well as a priority indicating how likely it is that the viewer will need that resource.

The cache priority value is a non-negative integer. The author can use a cache priority value of 0 to indicate that the referenced content is useful, but that the author may be unsure of its likelihood of use in comparison with other items that they are requesting to be cached. The author can use a cache priority value of 1 to indicate the belief that caching the specified resource is very important. A very large value for the priority indicates that a resource will likely not be used (hence informing the user agent that it may reclaim the memory currently used to hold the URL's associated resource in cases where it is needed).

The `remove` method may be used to remove a cached copy of the resource associated with the URL argument. Since it is to be removed from the cache, and not just invalidated, the system will not waste resources re-validating the entry. Note that invoking the `remove` method is different from assigning a very large integer as the cache priority value in that assigning such a large integer value only makes the space used to store that resource more available for garbage collecting and/or to hold high priority resources.

```
Interface cache {
    void prefetch(in DOMString URL, in short priority);
    void remove (in DOMString URL);
};
```

Binding of the Cache Interface to Script

The Cache Object, which implements the cache interface above, is accessible as a property of the Navigator (`Navigator::cache`).

Object **cache**

The **cache object** has the following methods:

prefetch(URLArg, priorityArg) - This method does not return a value.

The URLArg is of type **String**.

The priorityArg is of type **Number**.

Remove(URLArg) - This method does not return a value.

The URLArg is of type **String**.

The farPrefetch Method

Sometimes the size of the resources needed for a given application is very large, and, in this case, it is often true that many of the resources, e.g., fonts, are actually sharable with other applications on different services. When such is the case, the shared resources are often bundled together and transmitted on a single service. Hence, there is a need for an application to be able to obtain resources from another service, which will usually require temporarily changing the tuner to a different frequency and/or at least choosing a different service that is carried on that frequency, caching the resources from that other service, and tuning back to the original service. Another example use case for this scenario is the case where a viewer wants to download mail or chat information or a game, then interact with the downloaded data while watching video that is broadcast on a different service from the downloaded data.

In one embodiment, the following JS method is provided to permit an application to tune to a different service and download information from that service, then automatically come back to the original service:

```
void navigator.cache.farPrefetch(carouselUrl, ArrayOfUrlsToLoad,  
functionToCallWhenDone)
```

Where the carouselURL is identified via the tvx: protocol.

The following actions may occur asynchronously when this function is called. First, the permission of the application is checked to ensure that it is allowed to change

the service. If this request is permitted, the specified service is tuned, all urls requested are cached, then the tuner/demuxer re-selects the previous service, and the `functionToCallWhenDone` is invoked. This call may be guaranteed not to cause a kill event to be generated for the application that requested the `farPrefetch`.

Event defining result of `farPrefetch` Method

The following event may be delivered to the cache object after the `farPrefetch` completes. The `detail` value indicates whether all requested resources were obtained or not. That is, in one embodiment, if less than all of the requested resources are obtained, then the `farPrefetch` may be considered to have failed. The content author should note that they are responsible for requesting all required resources when a `farPrefetch` is used.

detail read-only property is a **Number**.

The **detail** property has the value: 1 for success,
NaN failure.

The **CacheEvent** object has the following method:

initCacheEvent(typeArg, canBubbleArg, cancelableArg, detailArg)

This method is used to initialize the value of a **CacheEvent** created through the **DocumentEvent** interface. This method may only be called before the **CacheEvent** has been dispatched.

The different types of cache events that can be dispatched to **navigator.cache** are:

FarPrefetchStatus - This event notifies that a farPrefetch() request has completed.

Bubbles : No
 Cancelable : No
 Context Info : **detail**

The Interaction Channel

HTML/JS applications may use the modem(s) attached to and/or present within a set-top box to interface with the interaction channel. Two types of modems are considered, an always-on modem (e.g., cable DOCSIS) and a use-time-only modem (e.g., POTS), either or both of which may be accessible from a given set-top box.

Two different uses of interaction channel have proven useful in interactive television. One use, which is also commonly found in PC applications, is the use of modems to send and/or receive a substantial amount of data. Since a substantial amount of data will be exchanged, the overhead of establishing a connection such as that associated with PPP is insignificant. A different use, however, has proven to be a source of major revenue generation for pay television operators: the capability to call a premium phone number, optionally exchange a few bytes, and hang up. The amount of time required to establish a PPP link in this second type of usage is therefore excessive, and, hence, undesirable.

In addition to the issue of use as described above, also important is the degree of control that an application may exercise over a modem connection. In one embodiment, if an application has not explicitly opened a link, the application may automatically open a link (e.g., using a network-dependent connection string), or use an existing open link, when access to content corresponding to an “http:” url is required by the application.

In order to permit developers to exercise control over high level protocols, such as PPP, the **links** structure described below may be provided. Further, to allow applications direct access to raw data where high level protocols cause too much overhead, and to allow those applications to dial premium phone numbers through dialup modems, the **modem** structure described below may be provided.

The Links Structure

The links structure defined below may be used to (1) explicitly control when connections are opened and closed, and (2) specify connection attributes. It also provides methods that allow an application to determine attributes of the link.

A user application may be configured to always select a *best* link (often designated by the network) and specify that as the default link ([window].navigator.tv.links.default below). In such a case, the author need not always search for a link with particular attributes. However, should an application author determine that they seek a particular type of link, they may directly access the links array ([window].navigator.tv.links[i] below).

Object Model Reference:

[window].navigator.tv.links[i]

[window].navigator.tv.links.default

The links array is a collection of objects of type TVLink as defined below. Also, the links.default is of type TVLink.

The type property allows the content author to determine the type of link. While the first three types are named according to the standardized protocol that they support,

the fourth type refers to a particular product that supports a more lightweight protocol in lower end boxes.

The status property allows an application to determine the current status of the link and the always_on property allows the application to determine whether the link is persistent. If the link is connected and not always on, the application can determine the amount of time that the link has been connected by using the time property.

It is typical in pay television networks for the networks themselves to require the connection attributes to be specified in a network-formatted way. That is, one network may require the application to specify the entire phone number, while another network will only permit an application to specify an index into an array of network-supplied phone numbers, and still a third network may not allow specification of the phone number at all, but only of the username and password. Therefore, the format of the connection string attribute associated with the connect request is network-dependent.

The **TVLink** object is defined as follows.

Properties:

type	“PPP” “DVB-RC” “DOCSIS” “OTV_Gateway” (read-only)
status	“connected” “connecting” “disconnected” “disconnecting”
(read-only)	
always_on	“True” “False”
time	int -- # seconds connected (0 if not in “connected” state)
name	String a unique property associated with this link.

Methods:

open(attributes, timeout) --

This method returns a Number: 1 for OK, -1 if the link that was specified does not exist, -2 if the link is already open, and -4 if permission to open this existing link is denied.

Note that although this call may fail immediately, the actual connection is asynchronous with the requester being notified via a LinkUp event when the connection has been successfully made. (or by a LinkDown event should the request fail)

The attributes parameter is String that contains the connection attributes as determined by the content author in consultation with the network (must at least know network-specified format)

The timeout parameter is Number that contains time-out (in seconds).

close()

This method returns a Number: 1 for OK, NaN for failure

This method may also be asynchronous.

addEventListener(type, listener, useCapture)

removeEventListener(type, listener, useCapture)

dispatchEvent(evt)

-- These methods are the basic methods of the DOM level 2 **EventTarget** interface.

Events:

The **LinkUp** and **LinkDown** events are of type **LinkEvent**. The **LinkEvent** object has all of the properties of the **Event** interface plus the following additional property:

detail read-only property is a **Number**.

Where the **detail** property has the value:

- 1 for normal disconnect,
- 2 for line was dropped (by other side),
- 3 time-out occurred,
- NaN other failure

The **LinkEvent** object has the following method:

initLinkEvent(typeArg, canBubbleArg, cancelableArg, detailArg)

This method is used to initialize the value of a LinkEvent created through The DocumentEvent interface. This method may only be called before the LinkEvent has been dispatched.

The different types of link events that can be dispatched to **navigator.modem** are:

LinkUp

This event notifies that a basic modem connection has been established.

- Bubbles : No
- Cancelable : No
- Context Info : none

LinkDown

This event notifies that the modem has been disconnected.

- Bubbles: No
- Cancelable: No
- Context Info: detail

The Modem Structure

The modem structure defined below is used for access to raw data. For example, this structure is useful when an application simply wants to dial a premium phone number, make a connection, and hang up. It can also be used when only a few bytes of information need to be exchanged, and, in such a situation, the higher level protocols required by the links structure above carry too much overhead for such a use.

Object Model Reference:

[window].navigator.modem

The **modem** object has the following methods:

connect(tel, timeout)

This method returns a **Number**: 1 for OK, -1 for parameter error, -7 modem is use, NaN other failure.

The **tel** parameter is type **String** that contains telephone number.

The **timeout** parameter is **Number** that contains time-out (in seconds).

disconnect()

This method returns a **Number**: 1 for OK, NaN for failure

sendData(data, timeout)

This method returns a **Number**: 1 for OK, -1 for parameter error, -2 not connected, NaN other failure.

The **data** parameter is type **String** that contains a sequence of byte values 0-255.

The **timeout** parameter is **Number** that contains time-out (in seconds).

receiveData()

This method returns a **String** that contains the available data (empty string if no data available).

addEventListener(type, listener, useCapture)

removeEventListener(type, listener, useCapture)

dispatchEvent(evt)

These methods are the basic methods of the DOM level 2 **EventTarget** interface.

The **ModemEvent** object has all the properties of the **Event** interface plus the following additional properties:

detail read-only property is a **Number**.

The **detail** property has the value: >0 for the number of bytes sent,
-2 for line was dropped (by other side),
-3 time-out occurred,
NaN other failure.

The **ModemEvent** object has the following method:

initModemEvent(typeArg, canBubbleArg, cancelableArg, detailArg)

This method is used to initialize the value of a **ModemEvent** created through the

DocumentEvent interface. This method may only be called before the ModemEvent has been dispatched.

The different types of modem events that can be dispatched to **navigator.modem** are:

ModemConnect

This event notifies that a basic modem connection has been established.

- Bubbles: No
- Cancelable: No
- Context Info: none

ModemDisconnect

This event notifies that the modem has been disconnected.

- Bubbles: No
- Cancelable: No
- Context Info: detail

The **detail** property has the value:

- 1 for normal disconnect,
- 2 for line was dropped (by other side),
- 3 time-out occurred,
- NaN other failure (e.g., authentication error).

ModemReceiveData

- Context Info: detail

The **detail** property contains the number of data bytes available to receive.

ModemSentData

This event notifies that a basic modem connection sent some data.

- Bubbles: No

- Cancelable: No
- Context Info: detail

5. USER INTERACTION

5.1 Navigation

Focus & focus highlight

CSS2 provides a number of ways to control how to highlight focused elements. For example, CSS2 provides three pseudo-classes related to focus navigation: “:hover”, “:active”, and “:focus”. In addition to these pseudo-classes, the html ‘tabindex’ attribute for input and anchor elements may also be utilized to support navigation. The purpose of this attribute is to allow the viewer to “tab” around the rendered page prior to selecting an element. The value assigned to the tabindex attribute determines the order in which the elements are visited upon tabbing.

Certain interactive television standards provide “nav-x” properties to support navigation using the arrow keys (DOM_VK_UP, DOM_VK_DOWN, DOM_VK_LEFT, and DOM_VK_RIGHT). In particular, both DVB MHP and Association of Radio Industries and Businesses (ARIB) define similar, though not identical, “nav-index”, “nav-right”, “nav-left”, “nav-up” and “nav-down” properties. In both of those specifications, the “nav-index” property is used to associate unique integer values with particular elements as follows.

`'nav-index'`

Value:	<code><integer> none</code>
Initial:	<code>none</code>
Applies to:	<code>All elements that can get focus</code>
Inherited:	<code>no</code>

Percentage Values: N/A

Media type: tv

Because elements with associated “nav-index” properties have associated unique integer values, the content author may then use the set of properties to control navigation between elements.

- nav-up
- nav-down
- nav-left, and
- nav-right

There are several differences between DVB-MHP’s definition of these properties and the definition provided by ARIB. DVB-MHP permits the use of this property to control navigation between frames by allowing the content author to specify a frame along with an element index to which to transition when the viewer presses the corresponding arrow key. It seems appropriate in high-end receivers to permit navigation between frames using this property, although it is not expected to be an issue in low to mid-size receivers.

Another difference between DVB-MHP’s definition of these properties and the definition assigned by ARIB is the behavior specified to occur when the content author does not provide one or more of these properties for various elements. ARIB indicates that if a particular property is not specified for an element, then pressing an arrow key when focused on that element results in no movement of focus. The result of applying this rule to elements for which none of these properties, except the nav-index, have been specified is that one can never navigate out of those elements, if indeed one can navigate to those elements. Additionally, if no nav-index property has been specified for an element, then it is not possible to navigate to that element. DVB-MHP specifies a

different default behavior wherein if one of the properties is not specified, then navigation via the arrow keys defaults to the pre-defined user agent behavior.

In one embodiment, if navigational direction is not explicitly controlled, the middleware (similar to the user agent) uses its default behavior for navigation. When the default behavior is not the behavior desired by the content author for a particular move, they may add directives for explicit control to override the undesirable behavior. In this manner, content authors are not required to explicitly re-define all of the behavior that they already find acceptable/desirable. Therefore the default behavior is more closely aligned with the behavior of DVB-MHP. The difference is to allow explicit specification of both “none” and “default” user agent behavior.

‘nav-up’

Value:	<integer> none default
Initial:	default
Applies to:	All elements that can get focus
Inherited:	no
Percentage Values:	N/A
Media type:	tv

‘nav-left’

Value:	<integer> none default
Initial:	default
Applies to:	All elements that can get focus
Inherited:	no
Percentage Values:	N/A
Media type:	tv

‘nav-down’

Value:	<integer> none default
--------	----------------------------

Initial:	default
Applies to:	All elements that can get focus
Inherited:	no
Percentage Values:	N/A
Media type:	tv

'nav-right'

Value:	<integer> none default
Initial:	default
Applies to:	All elements that can get focus
Inherited:	no
Percentage Values:	N/A
Media type:	tv

Usage example:

```
<FORM action="http://somesite.com/prog/adduser" method="post">
<P>
First name: <INPUT style="nav-index:100; nav-up:105; nav-down:101" type="text"
name="firstname"><BR>
Last name: <INPUT style="nav-index:101; nav-up:100; nav-down:102" type="text"
name="lastname"><BR>
email: <INPUT style="nav-index:102; nav-down:103; nav-up:101" type="text"
name="email"><BR>
<INPUT style="nav-index:103; nav-down:104; nav-up:102" type="radio"
name="gender" value="Male"> Male<BR>
<INPUT style="nav-index:104; nav-down:105; nav-up:103" type="radio"
name="gender" value="Female"> Female<BR>
<INPUT style="nav-index:105; nav-up:104; nav-down:100" type="submit"
value="Send"> <INPUT type="reset">
</P>
```

</FORM>

A content developer requiring additional control over navigation may specify key event handlers using Javascript.

5.2 Virtual Keyboard control

The following CSS property may be used for controlling the automated appearance of a keyboard. This property may be specified on a per-element basis for text, password, and text area elements. Hence, if an application is aware that a particular form element is a zip code for example, and hence entering numbers via the remote control is easier, that may be specified.

“virtual-keyboard”

Value:	disable enable auto
Initial:	enable
Applies to:	all input elements
Inherited:	no
Percentage Values:	N/A
Media type:	tv

The value “disable” means that the virtual keyboard is not available when the viewer wants to enter data into the area, i.e., they may enter numbers via the remote control instead. The value “auto” means that when the element to which the property applies receives focus, the virtual keyboard will automatically be presented to the viewer. The value “enable” means that the virtual keyboard will automatically be presented to the viewer when the viewer selects the element to which the property applies. If the viewer’s user preferences have indicated that there is an alternate preferred non-virtual

keyboard available, then the virtual keyboard may not be displayed even if the value has been set to enable or auto.

An example demonstrating how application writers could prevent the virtual keyboard from appearing for a password type element is:

```
Input [typ=password] {virtual-keyboard:disable}
```

Similarly, if the user preference indicates that the remote control may be used as a numeric speller, as with a cell phone, then no virtual keyboard will automatically appear. Alternatively, the network operator may specify a system preference if it knows that all viewers will have access to a physical keyboard or a cell phone.

5.3 Key Input

Applications may specify sets of keys for which they request notification by the system when they are in a maximized state. Generally, though not necessarily, they may not receive notification when they are in a minimized state. Notification of certain of the sets of keys will be provided to applications solely on the basis that they requested them.

However, for other keys, the network-supplied task may be queried as to whether or not the application may be presented with the keys that it has requested. Hence, it is possible that applications may not be notified of all key presses to which they have subscribed. HTML applications may specify which keys they wish to receive notification by stipulating sets of *key groups* shown in the key-list property below. If the system grants the key group request, then notification of the key press is given only to the requesting application and will not be delivered to other (native) applications in the system.

For example, an application may know that a viewer may only be entering digits between 1 and 8, yet wants to be forgiving enough so that if the viewer may enter a 0 or a 9, the channel will not change. In this case, the application can request notification of all of the numeric keys, ignoring anything except the digits between 1 and 8. It is possible that in some networks there will be a pre-defined set of keys that all pages which do not specify otherwise, will receive.

5.4 Key-list property

HTML type applications may add a CSS property called Key-list that indicates for which key presses an application may be notified. This property may apply to the body element. A content provider wishing more control can use the appropriate javascript to implement more fine-grained control, making use of the on-focus event. All pages using the same style sheet will share the same definition of keys, in which the application is interested. This is a comma-separated list of key-groups (such as navigation, selection, information, numeric, color, alpha, etc). Note that included included below is the reserved_set in the initial value for key-list even though these keys are typically not explicitly so marked on a typical remote control. Therefore, even though they're in the initial set, there may be no way for a viewer to use these keys. An application writer is therefore advised to exercise care when requesting that the viewer press these keys (e.g., have a fallback available in the event that these keys are not available to a particular viewer.)

“key-list”

Value	:	<key-group> + none
Initial	:	scroll_set, navigation_set, selection_set, numeric_set, punctuation_set, alpha_upper_set, alpha_lower_set, reserved_set
Applies to	:	body element

Inherited : no
 Percentage Values : N/A
 Media type : tv

Where key groups may be:

KEY GROUP	KEYS
user_information_set	HELP, INFO
scroll_set	HOME, PAGE_UP, PAGE_DOWN, END
navigation_set	LEFT_ARROW, RIGHT_ARROW, DOWN_ARROW, UP_ARROW
selection_set	CANCEL, ENTER, UNDO
vcr_control_set	STOP, PLAY, PAUSE, RECORD and SINGLE_STEP_FORWARD, SINGLE_STEP_REVERSE, FAST_FORWARD, FAST_REVERSE
edition_set	CUT, COPY, PASTE
teletext_set	MIXING, MAGNIFY, CONTENT, REVEAL
color_set	RED, GREEN, BLUE, YELLOW
numeric_set	0 to 9
Punctuation_set	all non-alphanumeric codes in (0x20 to 0x7f)
alpha_upper_set	all alphabetic codes in (0x41 to 0x5a)
alpha_lower_set	all alphabetic codes in (0x61 to 0x7a)
network_set	all codes in (0x0080 to 0x8f)
manufacturer_set	all codes in (0x0090 to 0x97)
Extended_set	all ISO-LATIN codes in (0x00a0 to 0xff)
sound_set	VOLUME_DOWN, VOLUME_UP, MUTE_AUDIO
station_set	CHANNEL_UP, CHANNEL_DOWN, PREVIOUS_CHANNEL, RADIO_TOGGLE, TV_TOGGLE
reserved_set	TAB, BACKSPACE, RETURN

Usage example:

```
<BODY style="key-list: selection_set, navigation_set">
```

5.5 Key codes

There are generally two major groups of key events.

The first contains the `textEvent` event. The `textEvent` event indicates that text information has been entered, either in the form of printable characters or non-printable text information such as modifier keys. These `textEvent` events are sometimes, but not necessarily, accompanied by the events of a second major groups of key events - `keydown` and `keyup`.

TextEvent

This event indicates that text information has been entered. The text information entered can originate from a variety of sources. It could, for example, be a character resulting from a keypress. It could also be a string resulting from an input method.

The `keydown` and `keyup` events comprise the second group of key events. These events are fired to indicate the physical motion of the keys on the character generation device. Depending on the input system being used, `textEvent` events may or may not be generated for each pair of `keydown` and `keyup` events.

keydown

The `keydown` event occurs when a key is pressed down.

keyup

The `keyup` event occurs when a key is released.

All these events may share the following attributes:

TextEvent, keydown, keyup:

bubbles: yes

cancelable: yes

context info: 0

context outputString: output generated by the key event or null.

context keyVal: Unicode character generated by the key event, or 0.

context virtkeyVal:

virtual key code generated by the key event if the key event has not a Unicode value, or DOM_VK_UNDEFINED. Here is the list of virtual key codes:

```

const unsigned long DOM_VK_UNDEFINED = 0x0;
const unsigned long DOM_VK_RIGHT_ALT = 0x01;
const unsigned long DOM_VK_LEFT_ALT = 0x02;
const unsigned long DOM_VK_LEFT_CONTROL = 0x03;
const unsigned long DOM_VK_RIGHT_CONTROL = 0x04;
const unsigned long DOM_VK_LEFT_SHIFT = 0x05;
const unsigned long DOM_VK_RIGHT_SHIFT = 0x06;
const unsigned long DOM_VK_LEFT_META = 0x07;
const unsigned long DOM_VK_RIGHT_META = 0x08;
const unsigned long DOM_VK_CAPS_LOCK = 0x09;
const unsigned long DOM_VK_DELETE = 0x0A;
const unsigned long DOM_VK_END = 0x0B;
const unsigned long DOM_VK_ENTER = 0x0C;
const unsigned long DOM_VK_ESCAPE = 0x0D;
const unsigned long DOM_VK_HOME = 0x0E;
const unsigned long DOM_VK_INSERT = 0x0F;
const unsigned long DOM_VK_NUM_LOCK = 0x10;
const unsigned long DOM_VK_PAUSE = 0x11;
const unsigned long DOM_VK_PRINTSCREEN = 0x12;
const unsigned long DOM_VK_SCROLL_LOCK = 0x13;
const unsigned long DOM_VK_LEFT = 0x14;
const unsigned long DOM_VK_RIGHT = 0x15;
const unsigned long DOM_VK_UP = 0x16;
const unsigned long DOM_VK_DOWN = 0x17;
const unsigned long DOM_VK_PAGE_DOWN = 0x18;
const unsigned long DOM_VK_PAGE_UP = 0x19;
const unsigned long DOM_VK_F1 = 0x1A;
const unsigned long DOM_VK_F2 = 0x1B;
const unsigned long DOM_VK_F3 = 0x1C;
const unsigned long DOM_VK_F4 = 0x1D;

```

```

const unsigned long DOM_VK_F5 = 0x1E;
const unsigned long DOM_VK_F6 = 0x1F;
const unsigned long DOM_VK_F7 = 0x20;
const unsigned long DOM_VK_F8 = 0x21;
const unsigned long DOM_VK_F9 = 0x22;
const unsigned long DOM_VK_F10 = 0x23;
const unsigned long DOM_VK_F11 = 0x24;
const unsigned long DOM_VK_F12 = 0x25;
const unsigned long DOM_VK_F13 = 0x26;
const unsigned long DOM_VK_F14 = 0x27;
const unsigned long DOM_VK_F15 = 0x28;
const unsigned long DOM_VK_F16 = 0x29;
const unsigned long DOM_VK_F17 = 0x2A;
const unsigned long DOM_VK_F18 = 0x2B;
const unsigned long DOM_VK_F19 = 0x2C;
const unsigned long DOM_VK_F20 = 0x2D;
const unsigned long DOM_VK_F21 = 0x2E;
const unsigned long DOM_VK_F22 = 0x2F;
const unsigned long DOM_VK_F23 = 0x30;
const unsigned long DOM_VK_F24 = 0x31;

const unsigned long DOM_VK_RC_POWER = 0x32;
const unsigned long DOM_VK_RC_TV = 0x33;
const unsigned long DOM_VK_RC_SET_UP = 0x34;
const unsigned long DOM_VK_RC_INFO = 0x35;
const unsigned long DOM_VK_RC_RADIO = 0x36;
const unsigned long DOM_VK_RC_NAV = 0x37;
const unsigned long DOM_VK_RC_PIP = 0x38;
const unsigned long DOM_VK_RC_MENU = 0x39;
const unsigned long DOM_VK_RC_TEXT = 0x3A;
const unsigned long DOM_VK_RC_HELP = 0x3B;
const unsigned long DOM_VK_RC_SELECT = 0x3C;
const unsigned long DOM_VK_RC_EXIT = 0x3D;
const unsigned long DOM_VK_RC_GUIDE = 0x3E;
const unsigned long DOM_VK_RC_RED = 0x3F;
const unsigned long DOM_VK_RC_GREEN = 0x40;
const unsigned long DOM_VK_RC_YELLOW = 0x41;
const unsigned long DOM_VK_RC_BLUE = 0x42;
const unsigned long DOM_VK_RC_CHANNEL_UP = 0x43;
const unsigned long DOM_VK_RC_CHANNEL_DOWN = 0x44;
const unsigned long DOM_VK_RC_VOLUME_UP = 0x45;
const unsigned long DOM_VK_RC_VOLUME_DOWN = 0x46;

```

```

const unsigned long DOM_VK_RC_MUTE = 0x47;
const unsigned long DOM_VK_RC_INFO = 0x48;
const unsigned long DOM_VK_RC_CANCEL = 0x49;
const unsigned long DOM_VK_RC_UNDO = 0x4A;
const unsigned long DOM_VK_RC_STOP = 0x4B;
const unsigned long DOM_VK_RC_PAUSE = 0x4C;
const unsigned long DOM_VK_RC_RESUME = 0x4D;
const unsigned long DOM_VK_RC_SINGLE_STEP_FORWARD = 0x4E;
const unsigned long DOM_VK_RC_SINGLE_STEP_REVERSE = 0x4F;
const unsigned long DOM_VK_RC_FAST_FORWARD = 0x50;
const unsigned long DOM_VK_RC_FAST_REVERSE = 0x51;
const unsigned long DOM_VK_RC_CUT = 0x52;
const unsigned long DOM_VK_RC_COPY = 0x53;
const unsigned long DOM_VK_RC_PASTE = 0x54;
const unsigned long DOM_VK_RC_MIXING = 0x55;
const unsigned long DOM_VK_RC_MAGNIFY = 0x56;
const unsigned long DOM_VK_RC_CONTENT = 0x57;
const unsigned long DOM_VK_RC_REVEAL = 0x58;
const unsigned long DOM_VK_RC_VCR = 0x59;
const unsigned long DOM_VK_RC_SATELLITE_DEL = 0x5A;
const unsigned long DOM_VK_RC_CABLE_DEL = 0x5B;
const unsigned long DOM_VK_RC_TERR_DEL = 0x5C;
const unsigned long DOM_VK_RC_DISPLAY_CLOCK = 0x5D;
const unsigned long DOM_VK_RC_SET_CLOCK = 0x5E;
const unsigned long DOM_VK_RC_COLOR_UP = 0x5F;
const unsigned long DOM_VK_RC_COLOR_DOWN = 0x60;
const unsigned long DOM_VK_RC_BRIGHT_UP = 0x61;
const unsigned long DOM_VK_RC_BRIGHT_DOWN = 0x62;
const unsigned long DOM_VK_RC_CONTRAST_UP = 0x63;
const unsigned long DOM_VK_RC_CONTRAST_DOWN = 0x64;
const unsigned long DOM_VK_RC_PREVIOUS_CHANNEL = 0x65;
const unsigned long DOM_VK_RC_PREFERENCES = 0x66;
const unsigned long DOM_VK_RC_PARENTAL_CONTROL = 0x67;
const unsigned long DOM_VK_RC_BOX_OFFICE = 0x68;
const unsigned long DOM_VK_RC_PURCHASE = 0x69;
const unsigned long DOM_VK_RC_PPV_SERVICES = 0x6A;
const unsigned long DOM_VK_RC_GO_ONLINE = 0x6B;
const unsigned long DOM_VK_RC_EXIT_APP = 0x6C;
const unsigned long DOM_VK_RC_SHOW_INTERACTIVE = 0x6D;
const unsigned long DOM_VK_RC_RECORD = 0x6E;

```

context inputGenerated:

false if the key event does not generate any visible output, such as the use of a function key or the combination of certain modifier keys used in conjunction with another key, true if the key event normally causes visible output. The value of inputGenerated does not guarantee the creation of a character, as the event may be canceled.

Context numPad:

If the number pad was used to generate the key event the value is true, otherwise the value is false.

While the codes above, and this data structure, are similar to those defined in DOM-Level 3 Key code definitions. Codes have been added for the remote control. These new codes have been named DOM_VK_RC_... (RC for remote control). In one embodiment, the keys on a keyboard which are labeled like these would generate these keys. Also, DOM_VK_HOME has been declared above in lieu of an RC_RIGHT, LEFT, RC_HOME, etc. Other keys are possible and are contemplated.

Key event methods

checkModifier

The CheckModifier method returns true or false, depending on whether a single modifier key is associated with a KeyEvent. The list of keys below represents the allowable modifier parameters for this method.

- DOM_VK_LEFT_ALT
- DOM_VK_RIGHT_ALT
- DOM_VK_LEFT_CONTROL
- DOM_VK_RIGHT_CONTROL
- DOM_VK_LEFT_SHIFT
- DOM_VK_RIGHT_SHIFT
- DOM_VK_META

Parameters

modifier of type unsigned long The modifier which the user wishes to query.

Return Value

Boolean The status of the modifier represented as a boolean.

No Exceptions

5.6 Event handlers

In addition to the Document Object Model (DOM) Level 2 listeners, Key events may be directed to legacy key handlers: `onKeyDown`, `onKeyPress`, `onKeyUp`, plus `onFocus`, `onBlur`, `onChange` and `onClick`, `onSubmit`.

6. SECURITY

Two types of security which may be required in a receiver include:

- (1) protection for html resources, including both document resources as well as cookies; and
- (2) protected access to receiver resources such as the tuner or modem.

Policies that govern the application of the various security mechanisms may be set by the network and/or by the receiver manufacturer and viewers themselves.

6.1 Protection For Html Resources

Same Origin Mechanism

The same origin policy may be defined in order to restrict one resource's capability to access other resources in such a way as to leave the viewer vulnerable. In particular, when one resource attempts to access one of the object properties shown in the table below, a same origin check is needed.

In one embodiment, the first step of a same origin check is to determine whether the object being referenced was created by the same context as the currently running script. If so, the access is permitted. Otherwise, additional information may be examined to determine whether the url of the accessing document has the same origin as the object being accessed. If the origin is the same, then the access may be permitted; otherwise, the access may be denied.

Two documents may be said to have the same origin if the following elements of the "protocol://host" (where host includes the optional port) are identical:

- the protocol,
- the host, and
- the port.

If any of these values differ, then the access may be denied. It may be assumed that any data that is acquired via the broadcast: is acquired on the same port.

Object	Property	Access Type	Checked
window	All except location (see below), frames, parent, and top	Read	yes

	All except location (see below)	Write	yes
(window.)location	All	Read	yes
	href	Write	yes
	protocol	Write	yes
	toString	(method)	yes

Mechanism and rules for changing the origin

It is often the case that a single organization may provide multiple servers, but may wish to allow certain documents provided from particular ones of these servers to access certain other documents provided from different ones of these servers. One mechanism to allow such sharing includes permitting a document to change its (document.)domain property. However, such changes may be restricted. For example, in one embodiment it may only change its domain to a proper suffix of its current domain. That is, www.xyz.com may be changed to xyz.com, but not to abc.com. Additionally, at least one period may be required to remain in the new name, so, for example, xyz.com could not be shortened at all. Consequently, if the origins of two different resources were originally www.xyz.com and intranet.xyz.com, both would have to change their domain in order for access to be allowed.

There may be a problem with the mechanism for changing the origin which relates to internationalization. The fact that this mechanism could be easily abused on servers outside the U.S. could open up the resource to all kinds of security attacks. Another potential problem is the granularity of this rule. Two resources from the same domain may not be able to provide mutual access only to one another without permitting

other resources in that domain the same access. This problem may be exacerbated by the mechanism that allows resources to change their domain.

One technique that would permit finer granularity of sharing uses a mechanism called a credential. In one embodiment, a credential is a signed *statement* from one party granting access to one (or more) of its resources to another party. The *statement* is a formatted chunk of data identifying the grantor, the grantee, the resource to which access is being granted, the permitted actions on that resource (i.e., read, write, or another property), and optionally a date until which that access is being permitted. The credential may be accompanied by a certificate chain, the leaf certificate in the chain identifying the grantor and providing their public key and the root certificate of the chain being identical to one of the root certificates in the receiver.

6.2 Protecting access to receiver resources

Networks often prefer to control access to certain hardware and software receiver resources. Those resources that may be granted to HTML applications which are acquired via the broadcast are enumerated below. The authorization process for granting these privileges to broadcast applications is described in later.

While applications which are obtained directly from the web may be prohibited from executing privileged operations, a special application, configured by or for the network operator known as the UI may access all of the privileged core operations.

In addition to the above, the network may be allowed to specify that certain of the operations below might be allowed to all apps, no matter where they're obtained from. Also, a network may be allowed to furnish domain-name/set-of-privileges pairs.

Privileged core operations

The following is a list of operations that may be permitted only when permission to access them is signaled as explained in the next section.

- Download modules from the broadcast
- Download modules from any source
- Switch tracks
- Switch programs (services)
- Connect to a remote server (via a phone or cable modem)
- Make any arbitrary connection
- Allow some modules not to be signed (the directory and initial modules must always be signed)
- Allow the application to become resident in the receiver
- Create or modify the service list
- Use the service list
- Request the viewer sign the data that they are providing for transmission
- Request the viewer approve access to restricted files and/or phone numbers
- Change some default settings (exactly which settings can be modified depends upon the other privileges granted to the application)
- Inform the system that it need not clean (non osd) memory after execution
- Inform the system that it need not clean the osd memory after execution
- Change the EIT cache window
- Release cache reserved for EIT
- Arbitrate between conflicting event broker requests

Allocating Receiver Privileges

In one embodiment, a directory module includes a corresponding per-application set of privileges that are requested. This directory module must contain a request for this set of privileges along with the producer's certificate and must be signed with the producer's private key. The producer's certificate is signed using the network's private

key. The producer's certificate states the maximum privileges that may be granted to any application under that producer. Hence, an application will only be granted a privilege if it is in its per-application set of privileges and it is among the set of maximum privileges that may be granted to any application associated with that producer. In addition to the signature, security is enhanced by requiring the signed directory to contain an accurate hash value corresponding to at least the initial code segment, and optionally to other code and data segments used by the application.

As stated above, all receiver privileges listed above may be granted to the special process known as UI. Additionally, privileges for applications received over the broadcast may be allocated in the same manner as they are allocated for core broadcast applications. Finally, applications received via the return channel may not be granted any receiver privileges. The set of privileges granted to a broadcast application or the UI application are known as its maximum set. Unless the application indicates otherwise using the methods described in the next section, its maximum set of privileges is equal to its current working set of privileges. Applications can set their current working set to a subset of their associated maximum set of privileges using the methods described below.

Least privileged mode

Using the methods described in this section, an application can execute in least-privileged mode. This is actually a much more secure mode which ensures that prior to using a privilege, an application specifically states that it is going to use that privilege. One advantage of this mode is that a content author cannot accidentally use a privilege that a network too freely grants. Using this mode, therefore, an application does not obtain more privileges than the network or receiver allows (known as the maximum set), but rather carefully manipulates a working set of privileges that are always a strict subset of that maximum set.

In order to support this mode, two new objects are required in the DOM: (1) the security object and (2) the privilegeManager object. The security object (of class "Security") is accessed through the "security" property of the global object (i.e., the window object). The security object's purpose currently is to contain a property, "privilegeManager", that allows access to the privilegeManager object (class "PrivilegeManager").

The privilegeManager object has four methods: enablePrivilege, disablePrivilege, revertPrivilege, and removePrivilege. These methods allow a script to manipulate privileges.

enablePrivilege Enables a privilege for the duration of the current function.

disablePrivilege Disables a privilege for the duration of the current function.

revertPrivilege Allows a script to revert a privilege to the state that it was in before the current function was called.

removePrivilege Allows a script to remove a privilege from its maximum set. (It is also removed from the working set if enabled.)

Each of these functions returns either true or false depending on whether the operation was successful. Note: when a function returns, any privileges enabled by that function may be automatically reverted to the state they were in at the point when the function was called. When a script attempts to perform a privileged operation without the necessary privilege enabled, an appropriate *TBD* exception will be thrown. If the exception is not caught, an error dialog box may be displayed before aborting the script.

Additional HTML-specific privileges

There are a set of privileges which are HTML-specific and mostly may be restricted to a subset of the broadcast html applications. A set of flags may be reserved to be used for additional restricted operations. In one embodiment, HTML applications may use one of these flags to indicate whether an application will be granted all of the following privileges. (That is, if the flag is set, the broadcast HTML application will be granted all of the privileges below and if it is not set, that application will be granted none of the privileges below.)

- Script can override the same origin policy, and read properties in another frame that was loaded from a different domain
- Script can override the same origin policy, and change properties in another frame that was loaded from a different domain.
- Script can query user preferences from the HTML Application only uim object.
- Script can create, change, and save user preferences from the HTML application only uim object.
- Script may submit a form to a mailto: URL
- Script may manipulate cookies when and if a more extensive cookie management system is added
- Script is granted the union of the runtime code extension privileges defined in both ATSC DASE 1 and DVB MHP 1.1.

Whether these privileges are granted to a broadcast application or not may be determined using the same mechanism as described in the section entitled “Allocating Receiver Privileges”. As above, these privileges may always be granted to the special UI application and/or never granted to applications that are not broadcast.

7. TOWARD A DECLARATIVE APPROACH TO AUTHORIZING FOR SHOWSTOPPERS AND PREFETCH PRIORITIES

Early programming languages were generally very *procedural* requiring a programmer to tell the computer *how* to carry out the program in detail. As the examples show, the trend has been towards languages where you specify *what* to do, but not how. Such languages may be said to be more *declarative*. Generally speaking, a declarative language is one in which you specify what you want, and not how to get it. Such languages may be particularly useful in providing higher level interfaces to underlying complex systems. For example, HTML may allow you to specify what is to appear on a page, but not how it is to be laid out. Another example is SQL where you specify what you want out of a database query, but do not give code for the looping and testing needed to produce it. It is noted that the discussion herein is not strictly limited to declarative languages per se. Rather, HTML, JavaScript, CSS, and other such languages and constructs are contemplated. In one embodiment, languages and constructs which are commonly used in creating and manipulating Web content are contemplated. In any such case, the declarations or other statements used in the creation and/or manipulation of resources and content in this document may be generally referred to as “directives”.

Background

This section (1) describes the showstopper and prefetch requirements; (2) identifies how such information may be carried in both DASE and DVB-MHP; and (3) proposes ways in which authors may indicate both showstopper and prefetch resources within their XHTML documents.

Although details of a transcoding implementation are not described, those skilled in the art may ascertain that the initial values assigned for showstopper and prefetch resources may be automatically translated to existing DASE/DVB-MHP facilities for transport.

Showstopper and prefetch requirements

The content creator often wishes to use multiple resources in constructing a scene or presentation and may consider the acquisition of a subset of these resources to be essential before displaying to the viewer. That is, they may prefer that the old scene should continue to be displayed until at least the essential resources have been received and decoded. These essential resources may be referred to as showstoppers because creators do not want anything displayed until at least these essential resources are available. Further, if these resources never become available, the content creator may prefer that nothing be displayed. In addition, marking these resources as essential may enable the broadcast stream to be more easily packaged together to enhance performance.

In general, performance may be enhanced by intelligent pre-fetching of resources. In particular, remarkable performance improvements may be possible when the pre-fetching priorities can be dynamically modified depending upon viewer interaction. Therefore, it is desirable to allow content authors to stipulate both essential resources as well as (dynamically modifiable) prefetch prioritization.

Fig. 5 illustrates one embodiment of a method for prefetching prerequisite resources. In the example shown, a centrally located proxy performs preprocessing or transcoding of content which is requested by a client or otherwise destined for a client. When the proxy receives content including presentation directives (block 502), the proxy may scan the content for directives which indicate certain content is deemed a prerequisite for the presentation. If no such directives are detected (decision block 504), then the directives (or signals and/or data corresponding to the presentation directives) are conveyed to the client (block 16) and the presentation may be initiated (block 518).

On the other hand, if such prerequisites directives are detected by the proxy, the proxy may immediately convey an indication to the client (block 506) that these identified resources are considered prerequisites. Upon receiving this indication, the client may then determine whether or not it currently has the identified prerequisite

resources (decision block 508). If the client does not have these resources, the client may then take any actions necessary to prefetch the prerequisite resources (block 510). Subsequently, or concurrently, the proxy may convey the remaining presentation content or directives to the client (block 512). Once the client has obtained the prerequisite resources (decision block 514), presentation of the content corresponding to the prerequisite resources is permitted.

It is to be understood that numerous alternatives are possible. For example, in an alternative embodiment, there is not proxy as described. Rather, the client is configured to process resources and content directly. In such an embodiment, the client may be configured to first scan received content for prerequisite directives. Alternatively, the prerequisite directives may be processed as received. Other embodiments are possible and are contemplated.

Support within DASE and DVB MHP

Currently neither DASE's DAE nor MHP's DVB-HTML provides a facility that allows content authors to identify showstoppers or prefetch prioritization. However, they do provide facilities which may be utilized for transporting such information.

Support within DASE

There is explicit support for identifying the initial static priority of resources within an application in DASE's root entity DTD. This support is in the form of the definition of a priority value for a cache item that is associated with a preload attribute. It perhaps in DASE Level 2, to enhance the root entity DTD so that it includes support for showstopper identification; that is, one possible embodiment would be to add an attribute called showstopper.

Prior to such addition, of course, DDE-2 could recommend the use of x-dde2-showstopper as a non-standardized attribute value. Elements identifying the showstoppers and initial pre-fetch priorities could be automatically formulated from the HTML enhancements proposed in the following section and, therefore, would be available to the receiver as soon as the application enters the initialized state. It would not be necessary to modify the prefetch priorities in the root element in response to user interaction, so this very minor enhancement, along with the authoring proposal below, would suffice for fully supporting prefetch and showstopper requirements in the DASE DAE.

Support within DVB-MHP

DVB-MHP provides an optional descriptor, known as the pre-fetch descriptor, within the AIT. As with the DASE root element preload attribute, this descriptor could be automatically generated from the HTML enhancements proposed below. The showstopper resources could be accommodated one of several ways; either by adding a new AIT descriptor for showstopper resources or, alternatively, by setting the priority of showstopper resources to the highest possible value (100).

PROPOSAL FOR AUTHORIZING

Showstoppers

Content authors may desire that there exist a way to identify those resources such that if they are not obtained by a receiver, displaying should be delayed.

Minimal proposal

It is proposed that DDE may define a profile for DDE specific META name/value pairs. Among those pairs would be the *name* “prerequisite,” with the *value* being the

target URI of the essential resource. An example of this name/value pair would be the one below which indicates that “background.mpg” is an essential resource that needs to be acquired and processed by the receiver prior to displaying the application’s initial content.

```
<META name=”prerequisite” content=”http://www.cnn.com/background.mpg”>
```

Prefetch prioritization

As mentioned earlier, content authors may wish to provide a hint concerning both broadcast parameters as well as caching behavior by indicating that it may be desirable to initially prefetch certain resources, independent of whether those resources are considered as essential or prerequisite resources as defined above. It is not necessary that the author-supplied initial prefetch prioritization be identical to the prioritization that is eventually carried in the corresponding signaling file (i.e., the DASE root element or the MHP prefetch descriptor). However, content developers are typically not very good at choosing from among too many different priorities. (Absolute numerical priorities, such as a value between 1 and 100 are often better chosen by more complicated metrics that account for the size of the resource, expected size of cache, rate of transmission of the broadcast stream, etc.)

Therefore, as proposed herein, the content author may be permitted to identify whether or not it is desirable for a receiver to prefetch a particular resource. For example, the content author may identify resources to be prefetched using the `link` element in the `<head>` of the initial document and by defining a new value “prefetch” for the `rel` attribute of this element. Since there may be several resources that the author would recommend for prefetching, they may indicate a prefetch priority as well. For example, they may order these multiple resources so that the first ones have higher priority than latter ones.

As the DOM allows dynamic modification of the list of `link` resources at runtime, e.g., based upon user interaction, modified `link` resources may serve as a hint to the receiver concerning dynamically changing priorities. However, it may also be useful to permit the content author to not only dynamically control prefetch priorities, but also to indicate that the use of a resource is imminent so that the terminal may wish to “precreate” the resource (e.g., allocate resources such as memory, and decode) instead of simply prefetching that resource. In order to permit the content author to accomplish this, a *cache* object may be used that implements both a `prefetch()` as well as a `precreate()` method.

8. EXTENDED UNIFORM RESOURCE IDENTIFIERS FOR TELEVISION BROADCASTS

The use of W3C standards for authoring interactive television content that is to be carried with digital television signals has begun to increase significantly. RFC 2838 (Uniform Resource Identifiers for Television Broadcasts) addressed the need to reference television broadcast streams as a whole; this section extends the description contained therein to include the ability to reference particular substreams and non-video resources that may also be carried in the broadcast stream. In addition to being useful directly within existing client set-top box or television implementations, the scheme described herein may be mapped to proposed transport-specific television schemes, e.g., `dvb`, `ocap`, and `arib`. The purpose of such mapping is to allow a content developer to author their content using the URI described herein, while permitting automatic (or manual) transcoding to one or more of the other proposed schemes.

Extended Television Uniform Resource Identifier (URI)

The basic structure of the extended television URI is:

tvx:<service-address>[<track-list>][<abs-path>]

where

<service-address> is a description of the data source, which may correspond to the DNS-style identifiers defined for “tv:” in RFC 2838. The optional

<track-list> can specify audio, video, subtitle, teletext, or data substreams within the stream emanating from the service-address. The

<abs-path> can be used to identify individual resources within a substream, or, since its syntax is quite flexible, can be further defined by various of the transport-specific URIs.

Current channel

The current channel can be specified as

tvx://current

This URI refers to whichever television broadcast is currently being accessed by the referring object. This definition differs from the “tv:” definition, as it is specific to the referring object. This difference is necessary because set-top boxes containing multiple tuners, decoders, etc. are becoming more commonplace.

This “current” broadcast may contain multiple audios (e.g., different languages), multiple videos (e.g., different camera angles), and different types of data. However, this URI refers to only those sub-streams that are being used by the destination associated with the referring object. For example, if there are both English and German sub-titles available, but the display associated with the object referencing this URI is only showing

the German sub-titles (i.e., is not showing the English sub-titles), then the English sub-titles would not be part of tvx://current.

Syntax (BNF) for Extended Television URIs

The following is an example of a formal specification for the extended television URIs:

```

tvx_uri           = "tvx:" [tvx_hier_part]
tvx_hier_part     = tvx_net_path | tvx_abs_path
tvx_net_path      = "://" service_addr [comp_list] [tvx_abs_path]
service_addr      = broadcast | "current"
comp_list         = ";" component *(", " component )
component         = stream_selector
stream_selector   = stream_type "=" stream_id
stream_type       = "video" | "audio" | "data" | "subtitle" |
"teletext"
stream_id         = 1*alphanum | "default" | "current" | "none"
tvx_abs_path      = "/" path_segments

```

where:

```

broadcast        may be as defined in RFC2838)
path_segments    may be as defined in RFC 2396
alphanum         may be as defined in RFC 2396

```

Semantics for Extended Television URIs

This section defines the meaning of the various forms of the extended television URIs.

Service Address Alone

The substream referenced by a service address alone may consist of video, audio, teletext, subtitle, and data streams. Data streams may contain executable code in addition to data used by that code or data used by a resident application. In addition, there may be more than one stream of each type in the referenced substream. For example, `tvx://bcd.com` may contain 2 video streams, 4 audio streams, one teletext stream, one subtitle stream, and five data streams. Which streams are “displayed” by the object referencing this URI can depend upon many factors. If the viewer has selected a default setting which indicates a preference concerning whether or not teletext and/or subtitles are displayed, then that preference may be used to determine whether these streams are displayed. Additionally a viewer may indicate a preferred audio language.

The broadcasting network may use signaling to indicate the default video stream, and, for example, in the case of DVB MHP, may indicate that particular applications should be downloaded and executed. If the receiver has the ability to decode at least one video stream and one audio stream concurrently, then in one embodiment at least one of each will be decoded when a `tvx` URI of this form is specified. Further, the viewer may be provided with controls which enable them to “mute” the audio or video. If the viewer has not muted a stream, but also has not selected a preference, and the network has not indicated a preference, then any one of the corresponding streams may be decoded and displayed.

As stated above, while a URI of the form “`tvx://current`” may also be used, referencing this URI does not generally change which streams are being decoded (and presented).

Specifying Components

The content author can reference particular substreams within the stream using this URI. For example, “`tvx://bcd.com;audio=eng`” may refer to an English audio substream. Also, more than one stream may be referenced using this form of the URI. For example, “`tvx://bcd.com;video=catcher;audio=eng`” may be used to refer to a video

which is shot from behind a baseball catcher along with the English audio. It is expected that the content author may have appropriate tools by which they can either set a “track tag” (e.g., catcher, eng) to correspond to a particular substream, or that a set of track tags may be determined by a standard or by a video producer, for example.

In one embodiment, there are two special keywords that may be used as track tags which are defined in this document: “current” and “default.” The “current” track tag indicates the substream that is currently being displayed. For example, if the viewer is currently watching a movie and is listening to the French audio, their audio may be changed to English without affecting the video through the use of the following URI: “tvx://current;video=current;audio=eng” (providing that the track tag “eng” had been associated with the audio).

The “default” keyword may be used to refer to the default as defined by the viewer, author, receiver, content author or some combination, as per a particular specification and/or instantiation. That is, in some vertical networks, the network operator may have the authority to set a default preference and in other networks, it may be up to the viewer.

Path Segments

Path segments may be used to identify a resource within a particular component. For example, “tvx://bcd.com;data=novice/game/chess/move3” may refer to the resource game/chess/move3 which is carried in the data substream with the track tag of novice.

Additional meanings may be assigned to the path segments when the various transport-specific television URIs are mapped to this URI. However, until they are so defined, path segments shall only be meaningful when the component type is data.

Various embodiments may further include receiving, sending or storing instructions and/or data implemented in accordance with the foregoing description upon a carrier medium. Generally speaking, a carrier medium may include transmission media or signals used in broadcast systems and otherwise such as electrical, electromagnetic, or digital signals, conveyed via a communication medium such as network and/or a wireless link. For example, a network operator may convey signals which describe program instructions via a broadcast system. A carrier medium may also include storage media or memory media such as magnetic or optical media, e.g., disk or CD-ROM, volatile or non-volatile media such as RAM (e.g. SDRAM, RDRAM, SRAM, etc.), ROM, etc.

It is to be understood that the above embodiments are intended to be exemplary only. Numerous alternative configurations are possible and are contemplated.

WHAT IS CLAIMED IS:

1. A method comprising:
 receiving one or more directives, wherein said directives are indicative of an audio, video and/or graphic presentation requiring a set of resources;
 determining from said directives that acquisition of a subset of said resources are a prerequisite to the presenting of said presentation; and
 prohibiting the presenting of said presentation until said subset of resources are acquired.

2. The method of claim 1, wherein said subset of resources are indicated using directives selected from the group consisting of: a markup language, a scripting language, and a style sheet.

3. The method of claim 2, wherein said directives are received by a proxy server in an interactive television system.

4. The method of claim 3, wherein said determining is performed by said proxy server, and wherein said method further comprises said proxy server conveying signals which correspond to said subset of resources to a remote client device.

5. The method of claim 4, further comprising said client device acquiring said subset of resources in response to detecting said signals.

6. The method of claim 5, wherein said subset comprises streaming audio and/or video, and wherein acquisition of the streaming audio and/or video comprises configuring hardware resources within said client device.

7. The method of claim 5, wherein acquisition of the subset of resources comprises the client device initiating requests for remotely located resources to be conveyed to said client device.

8. The method of claim 1, further comprising enhancing a root entity in DTD to add a showstopper attribute indicative of prerequisite resources.
9. The method of claim 1, further comprising using a label within a Declarative Data Essence standard as an attribute to indicate a prerequisite resource.
10. The method of claim 1, further comprising enhancing DVB-MHP by adding a showstopper AIT descriptor indicative of prerequisite resources.
11. The method of claim 1, further comprising defining a META name/value pair, wherein said name is indicative that said corresponding value is a prerequisite resource.
12. The method of claim 1, wherein said prohibiting is in further response to detecting a corresponding time for expiration has not yet expired, and wherein said method further comprises allowing the presenting of said presentation in response to detecting said time for expiration has expired.
13. An interactive television system comprising:
 - a remote proxy server configured to:
 - receive one or more directives, wherein said directives are indicative of an audio, video and/or graphic presentation requiring a set of resources;
 - determine from said directives that acquisition of a subset of said resources are a prerequisite to the presenting of said presentation;
 - convey first signals which identify said subset of resources to a remote client device; and
 - convey second signals which correspond to said directives.

a client device configured to:

receive said first signals;
receive said second signals; and
prohibit the presenting of said presentation until said subset of resources
are acquired, in response to detecting said first signals.

14. The system of claim 13, wherein said subset of resources are indicated using directives selected from the group consisting of: a markup language, a scripting language, and a style sheet.

15. The system of claim 14, wherein acquiring said subset of resources comprises said client device configuring hardware resources within said client device.

16. The system of claim 14, wherein acquiring said subset of resources comprises initiating requests for remotely located resources to be conveyed to said client device.

17. The system of claim 13, further comprising enhancing a root entity in DTD by adding a showstopper attribute indicative of prerequisite resources.

18. The system of claim 13, wherein said directives include the use of a showstopper attribute indicative of prerequisite resources.

19. The system of claim 13, wherein said server is configured to detect a DVB-MHP showstopper AIT descriptor indicative of prerequisite resources.

20. The system of claim 13, wherein said directives define a META name/value pair, wherein said name is indicative that said corresponding value is a prerequisite resource.

21. The system of claim 13, wherein said device is configured to prohibit said presenting in further response to detecting a corresponding time for expiration has not yet expired, and wherein said device is further configured to allow the presenting of said presentation in response to detecting said time for expiration has expired.

22. A client device in an interactive television system, said device comprising:
- a receiver configured to receive signals corresponding to directives which are indicative of an audio, video and/or graphic presentation requiring a set of resources; and
- a processing unit coupled to said receiver, wherein said processing unit is configured to:
- determine from said directives that acquisition of a subset of said resources are a prerequisite to the presenting of said presentation;
- and
- prohibit the presenting of said presentation until said subset of resources are acquired.
23. A carrier medium comprising program instructions executable to:
- receive directives which are indicative of an audio, video and/or graphic presentation requiring a set of resources;
- determine from said directives that a subset of said resources are a prerequisite to the presenting of said presentation; and
- prohibit the presenting of said presentation until said subset of resources are acquired.

ABSTRACT OF THE DISCLOSURE

A method and mechanism for enabling the creation and/or control of interactive television content using declarative-like directives such as HTML, scripting languages, or other languages. A centrally located proxy server is configured to receive, transcode and convey transcoded web based content to client devices. Upon detecting directives which indicate particular resources required for a presentation are prerequisites, the proxy server conveys signals to a client device that these particular resources are prerequisites. In response to receiving the conveyed signals, the client device may take actions to prefetch these resources. The client device is further configured to prohibit initiation of the presentation until the prerequisite resources are acquired.

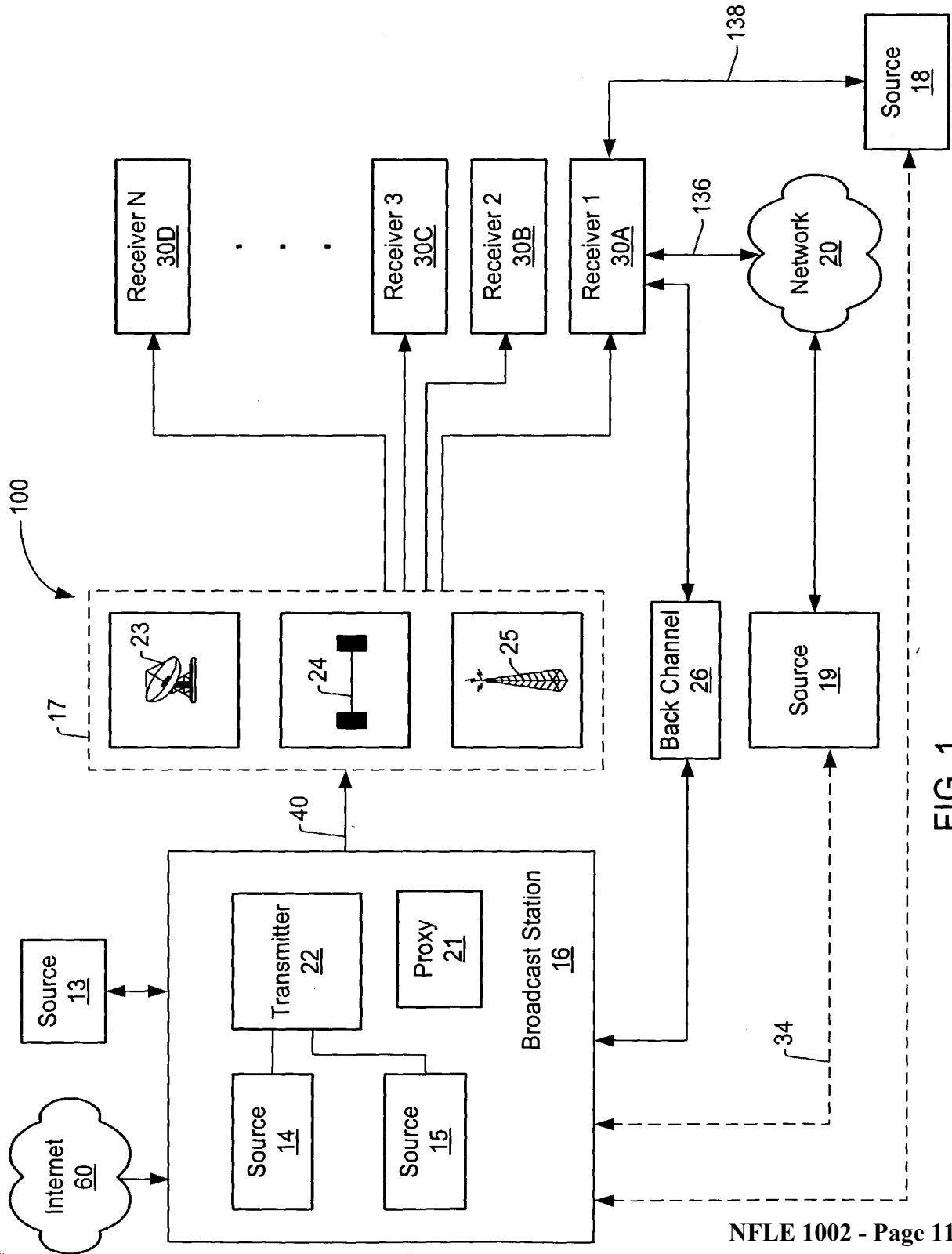

FIG. 1

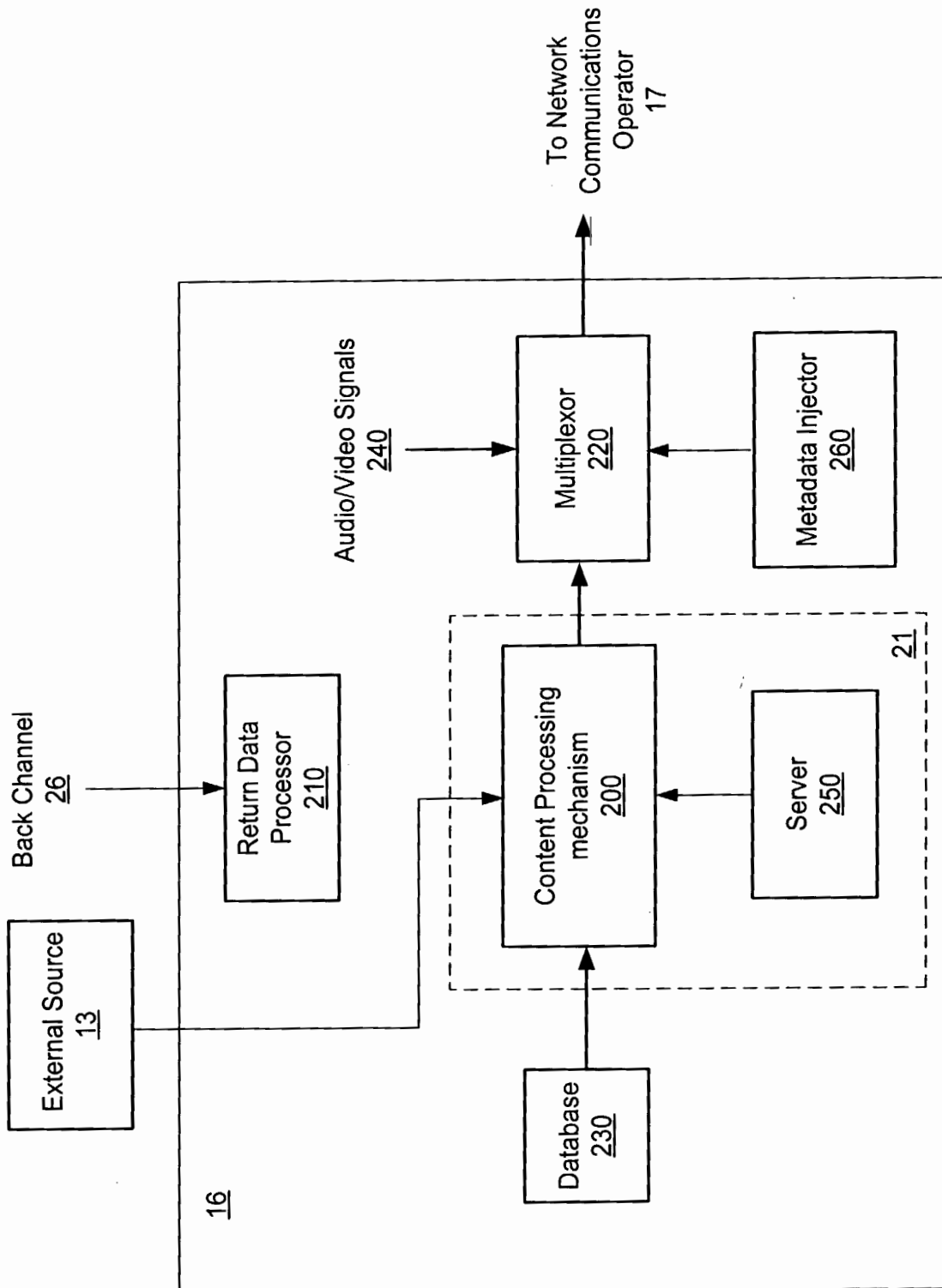

FIG. 2

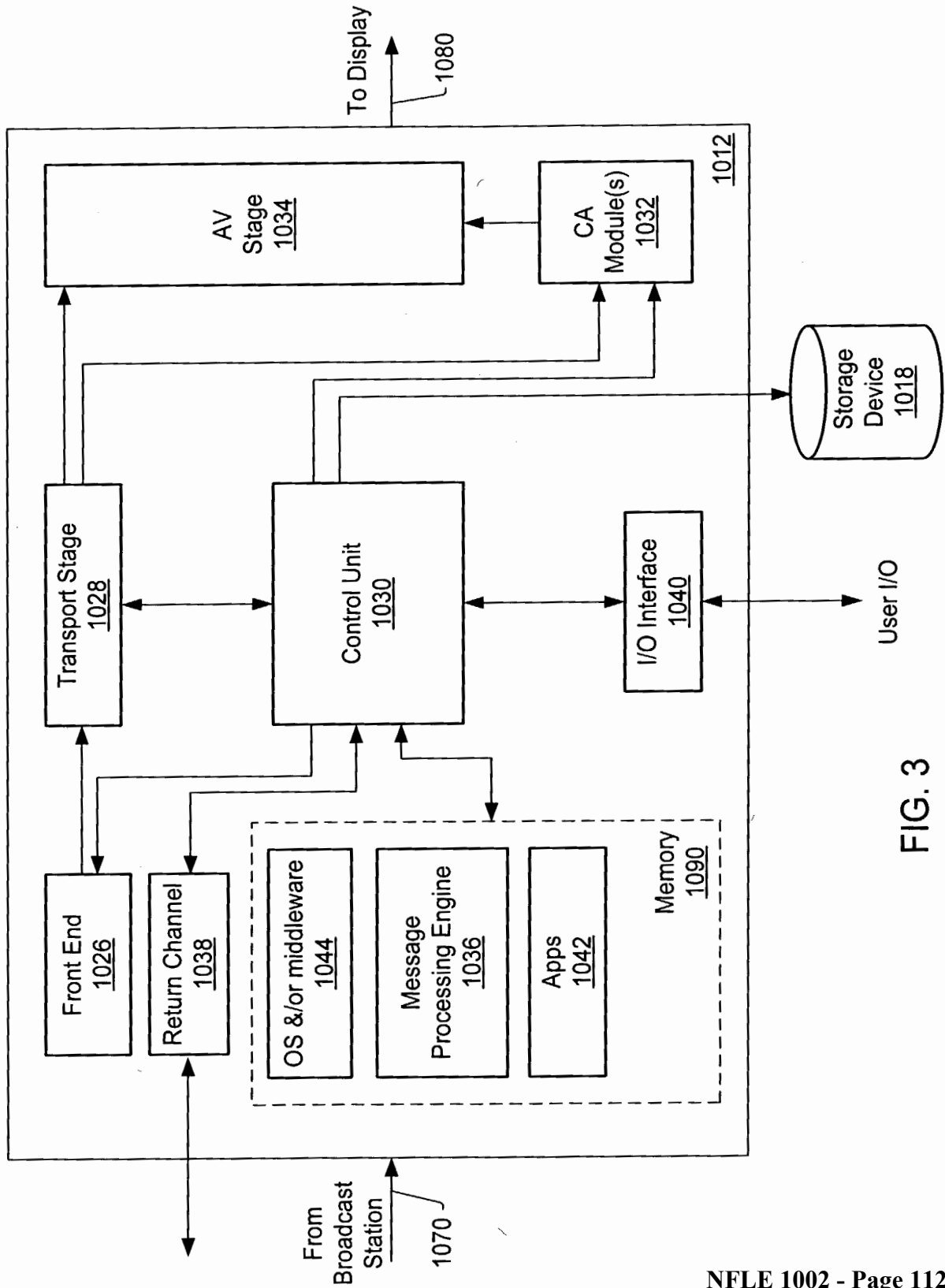

FIG. 3

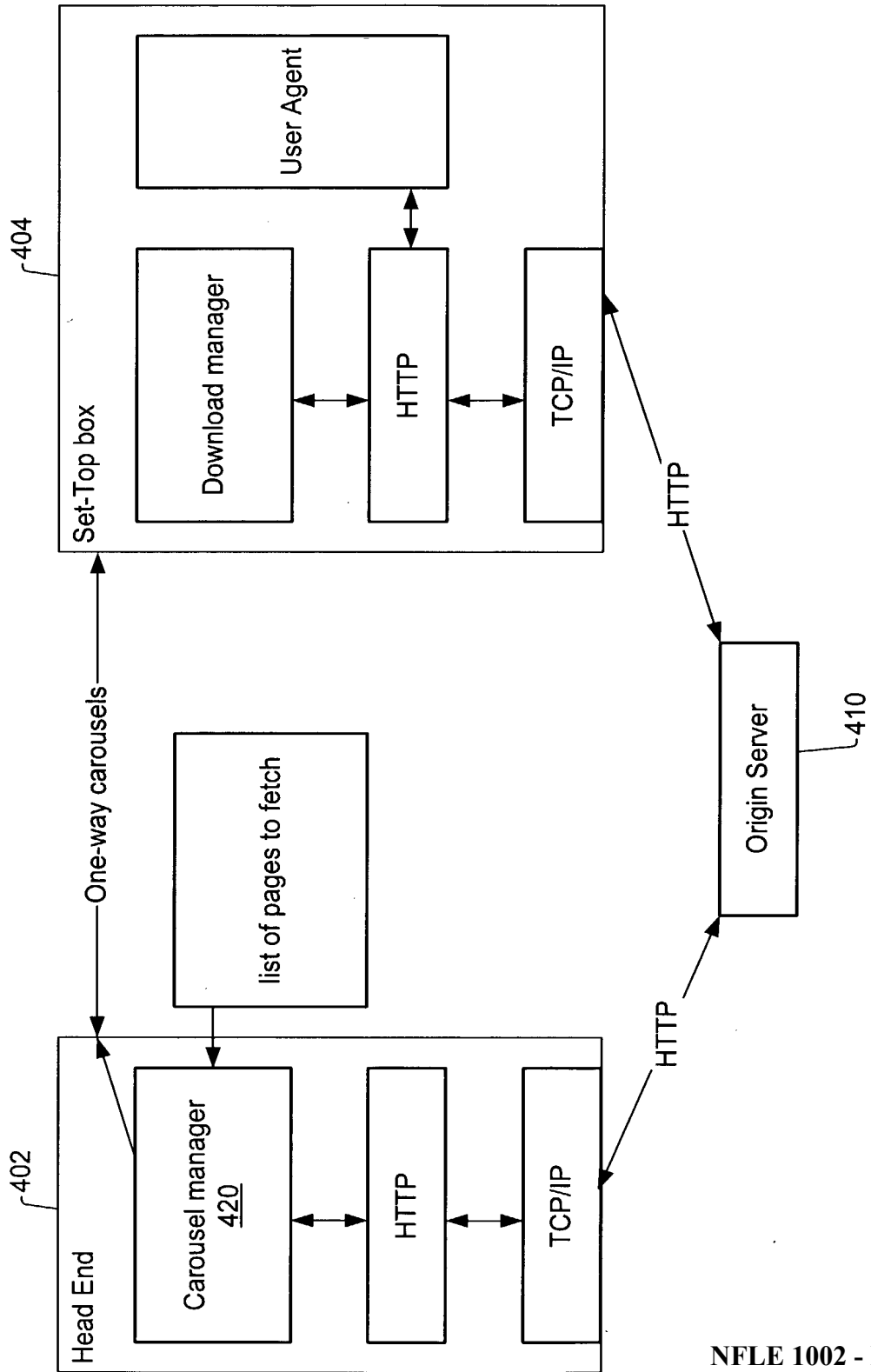

FIG. 4

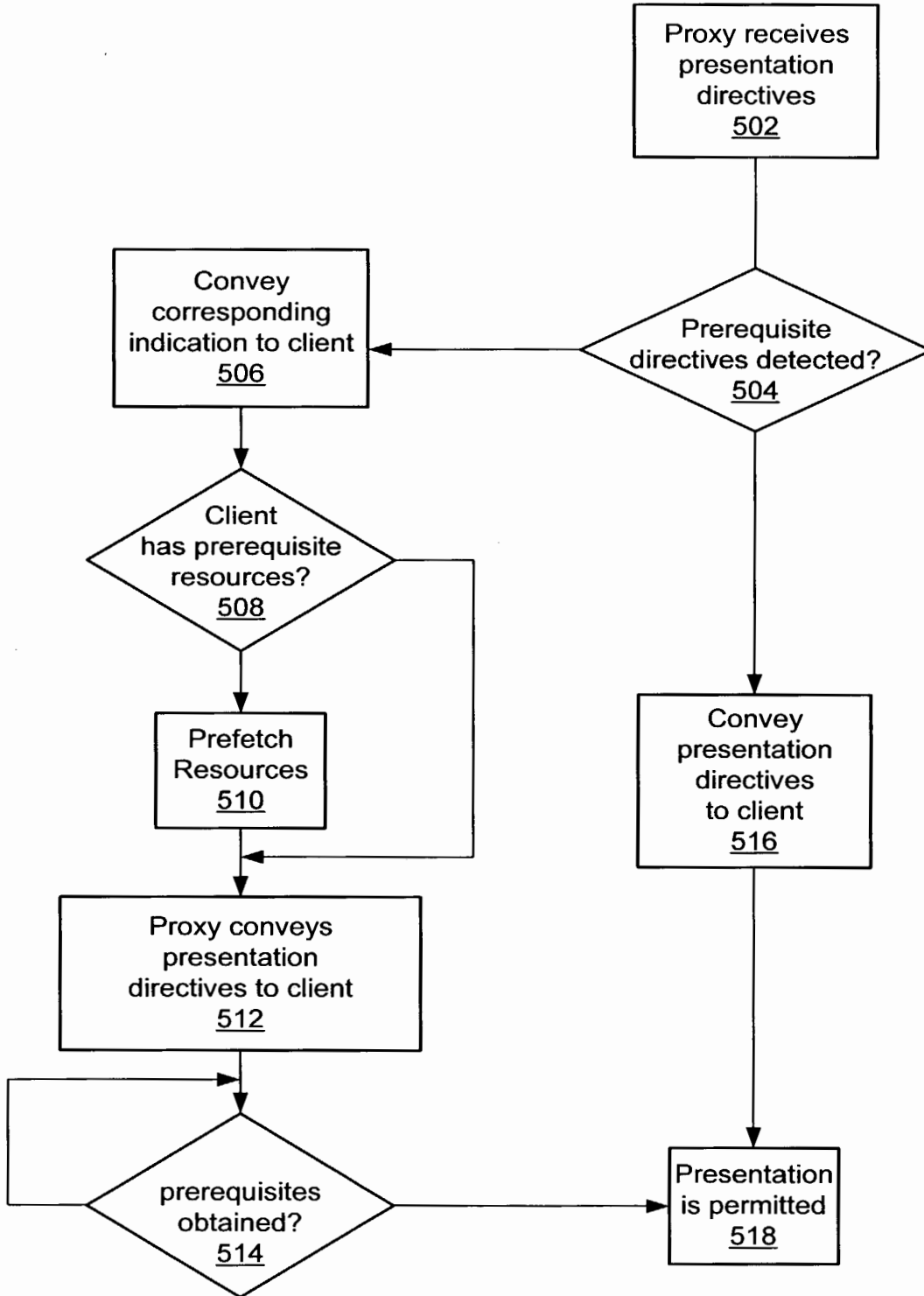

FIG. 5

ASSIGNMENT

FOR GOOD AND VALUABLE CONSIDERATION, the receipt, sufficiency and adequacy of which are hereby acknowledged, the undersigned, does hereby:

SELL, ASSIGN AND TRANSFER to OpenTV, Inc. (the "Assignee"), a corporation having its principal place of business at 401 East Middlefield Road, Mountain View, California 94043-4005, the entire right, title and interest for the United States and all foreign countries, in and to any and all improvements which are disclosed in the application for United States Letters Patent, which has been executed by the undersigned concurrently herewith, and is entitled "**SUPPORTING COMMON INTERACTIVE TELEVISION FUNCTIONALITY THROUGH PRESENTATION ENGINE SYNTAX**," the specification of which was filed on **April 19, 2002**, receiving the Serial No. **60/373,883**, such application and all divisional, continuing, substitute, renewal, reissue and all other applications for patent which have been or shall be filed in the United States and all foreign countries on any of such improvements; all original and reissued patents which have been or shall be issued in the United States and all foreign countries on such improvements; and specifically including the right to file foreign applications under the provisions of any convention or treaty and claim priority based on such application in the United States;

AUTHORIZE AND REQUEST the issuing authority to issue any and all United States and foreign patents granted on such improvements to the Assignee;

WARRANT AND COVENANT that no assignment, grant, mortgage, license or other agreement affecting the rights and property herein conveyed has been or will be made to others by the undersigned, and that the full right to convey the same as herein expressed is possessed by the undersigned;

COVENANT that, when requested and at the expense of the Assignee, to carry out in good faith the intent and purpose of this assignment, the undersigned will execute all divisional, continuing, substitute, renewal, reissue, and all other patent applications on any and all such improvements; execute all rightful oaths, declarations, assignments, powers of attorney and other papers; communicate to the Assignee all facts known to the undersigned relating to such improvements and the history thereof; and generally do everything possible which the Assignee shall consider desirable for securing, maintaining and enforcing proper patent protection for such improvements and for vesting title to such improvements in the Assignee;

COVENANT AND AGREE that the above is and will be binding on the heirs, assigns, representatives and successors of the undersigned and extend to the successors, assigns and nominees of the Assignee.

Inventor Signature _____ Date: _____
Name: Alain DELPUCH

Inventor Signature _____ Date: _____
Name: James WHITLEDGE

Inventor Signature _____ Date: _____
Name: Jean-Rene MENAND

Inventor Signature _____ Date: _____
Name: Emmanuel BARBIER

Inventor Signature  _____ Date: 8/28/02
Name: Kevin HAUSMAN

Inventor Signature _____ Date: _____
Name: Debra HENSGEN

Inventor Signature _____ Date: _____
Name: Dongmin SU

ASSIGNMENT

FOR GOOD AND VALUABLE CONSIDERATION, the receipt, sufficiency and adequacy of which are hereby acknowledged, the undersigned, does hereby:

SELL, ASSIGN AND TRANSFER to OpenTV, Inc. (the "Assignee"), a corporation having its principal place of business at 401 East Middlefield Road, Mountain View, California 94043-4005, the entire right, title and interest for the United States and all foreign countries, in and to any and all improvements which are disclosed in the application for United States Letters Patent, which has been executed by the undersigned concurrently herewith, and is entitled "**SUPPORTING COMMON INTERACTIVE TELEVISION FUNCTIONALITY THROUGH PRESENTATION ENGINE SYNTAX**," the specification of which was filed on **April 19, 2002**, receiving the Serial No. **60/373,883**, such application and all divisional, continuing, substitute, renewal, reissue and all other applications for patent which have been or shall be filed in the United States and all foreign countries on any of such improvements; all original and reissued patents which have been or shall be issued in the United States and all foreign countries on such improvements; and specifically including the right to file foreign applications under the provisions of any convention or treaty and claim priority based on such application in the United States;

AUTHORIZE AND REQUEST the issuing authority to issue any and all United States and foreign patents granted on such improvements to the Assignee;

WARRANT AND COVENANT that no assignment, grant, mortgage, license or other agreement affecting the rights and property herein conveyed has been or will be made to others by the undersigned, and that the full right to convey the same as herein expressed is possessed by the undersigned;

COVENANT that, when requested and at the expense of the Assignee, to carry out in good faith the intent and purpose of this assignment, the undersigned will execute all divisional, continuing, substitute, renewal, reissue, and all other patent applications on any and all such improvements; execute all rightful oaths, declarations, assignments, powers of attorney and other papers; communicate to the Assignee all facts known to the undersigned relating to such improvements and the history thereof; and generally do everything possible which the Assignee shall consider desirable for securing, maintaining and enforcing proper patent protection for such improvements and for vesting title to such improvements in the Assignee;

COVENANT AND AGREE that the above is and will be binding on the heirs, assigns, representatives and successors of the undersigned and extend to the successors, assigns and nominees of the Assignee.

Inventor Signature _____ Date: _____
Name: Alain DELPUCH

Inventor Signature _____ Date: _____
Name: James WHITLEDGE

Inventor Signature _____ Date: _____
Name: Jean-Rene MENAND

Inventor Signature _____ Date: _____
Name: Emmanuel BARBIER

Inventor Signature _____ Date: _____
Name: Kevin HAUSMAN

Inventor Signature _____ Date: _____
Name: Debra HENSGEN

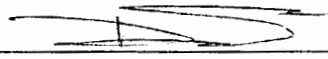
Inventor Signature  _____ Date: Aug 26, 2002
Name: Dongmin SU

ASSIGNMENT

FOR GOOD AND VALUABLE CONSIDERATION, the receipt, sufficiency and adequacy of which are hereby acknowledged, the undersigned, does hereby:

SELL, ASSIGN AND TRANSFER to OpenTV, Inc. (the "Assignee"), a corporation having its principal place of business at 401 East Middlefield Road, Mountain View, California 94043-4005, the entire right, title and interest for the United States and all foreign countries, in and to any and all improvements which are disclosed in the application for United States Letters Patent, which has been executed by the undersigned concurrently herewith, and is entitled "**SUPPORTING COMMON INTERACTIVE TELEVISION FUNCTIONALITY THROUGH PRESENTATION ENGINE SYNTAX,**" the specification of which was filed on **April 19, 2002**, receiving the Serial No. **60/373,883**, such application and all divisional, continuing, substitute, renewal, reissue and all other applications for patent which have been or shall be filed in the United States and all foreign countries on any of such improvements; all original and reissued patents which have been or shall be issued in the United States and all foreign countries on such improvements; and specifically including the right to file foreign applications under the provisions of any convention or treaty and claim priority based on such application in the United States;

AUTHORIZE AND REQUEST the issuing authority to issue any and all United States and foreign patents granted on such improvements to the Assignee;

WARRANT AND COVENANT that no assignment, grant, mortgage, license or other agreement affecting the rights and property herein conveyed has been or will be made to others by the undersigned, and that the full right to convey the same as herein expressed is possessed by the undersigned;

COVENANT that, when requested and at the expense of the Assignee, to carry out in good faith the intent and purpose of this assignment, the undersigned will execute all divisional, continuing, substitute, renewal, reissue, and all other patent applications on any and all such improvements; execute all rightful oaths, declarations, assignments, powers of attorney and other papers; communicate to the Assignee all facts known to the undersigned relating to such improvements and the history thereof; and generally do everything possible which the Assignee shall consider desirable for securing, maintaining and enforcing proper patent protection for such improvements and for vesting title to such improvements in the Assignee;

COVENANT AND AGREE that the above is and will be binding on the heirs, assigns, representatives and successors of the undersigned and extend to the successors, assigns and nominees of the Assignee.

Inventor Signature _____ Date: _____
Name: Alain DELPUCH

Inventor Signature _____ Date: _____
Name: James WHITLEDGE

Inventor Signature Jean-Rene Menand Date: 10/4/2002
Name: Jean-Rene MENAND

Inventor Signature _____ Date: _____
Name: Emmanuel BARBIER

Inventor Signature _____ Date: _____
Name: Kevin HAUSMAN

Inventor Signature Debra Hensgen Date: 10/4/02
Name: Debra HENSGEN

Inventor Signature _____ Date: _____
Name: Dongmin SU

ASSIGNMENT

FOR GOOD AND VALUABLE CONSIDERATION, the receipt, sufficiency and adequacy of which are hereby acknowledged, the undersigned, does hereby:

SELL, ASSIGN AND TRANSFER to OpenTV, Inc. (the "Assignee"), a corporation having its principal place of business at 401 East Middlefield Road, Mountain View, California 94043-4005, the entire right, title and interest for the United States and all foreign countries, in and to any and all improvements which are disclosed in the application for United States Letters Patent, which has been executed by the undersigned concurrently herewith, and is entitled "**SUPPORTING COMMON INTERACTIVE TELEVISION FUNCTIONALITY THROUGH PRESENTATION ENGINE SYNTAX**," the specification of which was filed on **April 19, 2002**, receiving the Serial No. **60/373,883**, such application and all divisional, continuing, substitute, renewal, reissue and all other applications for patent which have been or shall be filed in the United States and all foreign countries on any of such improvements; all original and reissued patents which have been or shall be issued in the United States and all foreign countries on such improvements; and specifically including the right to file foreign applications under the provisions of any convention or treaty and claim priority based on such application in the United States;

AUTHORIZE AND REQUEST the issuing authority to issue any and all United States and foreign patents granted on such improvements to the Assignee;

WARRANT AND COVENANT that no assignment, grant, mortgage, license or other agreement affecting the rights and property herein conveyed has been or will be made to others by the undersigned, and that the full right to convey the same as herein expressed is possessed by the undersigned;

COVENANT that, when requested and at the expense of the Assignee, to carry out in good faith the intent and purpose of this assignment, the undersigned will execute all divisional, continuing, substitute, renewal, reissue, and all other patent applications on any and all such improvements; execute all rightful oaths, declarations, assignments, powers of attorney and other papers; communicate to the Assignee all facts known to the undersigned relating to such improvements and the history thereof; and generally do everything possible which the Assignee shall consider desirable for securing, maintaining and enforcing proper patent protection for such improvements and for vesting title to such improvements in the Assignee;

COVENANT AND AGREE that the above is and will be binding on the heirs, assigns, representatives and successors of the undersigned and extend to the successors, assigns and nominees of the Assignee.

Inventor Signature _____ Date: _____
Name: Alain DELPUCH

Inventor Signature James R. Whitley Date: 8/26/02
Name: James WHITLEDGE

Inventor Signature _____ Date: _____
Name: Jean-Rene MENAND

Inventor Signature _____ Date: _____
Name: Emmanuel BARBIER

Inventor Signature _____ Date: _____
Name: Kevin HAUSMAN

Inventor Signature _____ Date: _____
Name: Debra HENSGEN

Inventor Signature _____ Date: _____
Name: Dongmin SU

PATENT
OPTV-187/PRV/US

ASSIGNMENT

FOR GOOD AND VALUABLE CONSIDERATION, the receipt, sufficiency and adequacy of which are hereby acknowledged, the undersigned, does hereby:

SELL, ASSIGN AND TRANSFER to OpenTV, Inc. (the "Assignee"), a corporation having its principal place of business at 401 East Middlefield Road, Mountain View, California 94043-4005, the entire right, title and interest for the United States and all foreign countries, in and to any and all improvements which are disclosed in the application for United States Letters Patent, which has been executed by the undersigned concurrently herewith, and is entitled "**SUPPORTING COMMON INTERACTIVE TELEVISION FUNCTIONALITY THROUGH PRESENTATION ENGINE SYNTAX**," the specification of which was filed on **April 19, 2002**, receiving the Serial No. **60/373,883**, such application and all divisional, continuing, substitute, renewal, reissue and all other applications for patent which have been or shall be filed in the United States and all foreign countries on any of such improvements; all original and reissued patents which have been or shall be issued in the United States and all foreign countries on such improvements; and specifically including the right to file foreign applications under the provisions of any convention or treaty and claim priority based on such application in the United States;

AUTHORIZE AND REQUEST the issuing authority to issue any and all United States and foreign patents granted on such improvements to the Assignee;

WARRANT AND COVENANT that no assignment, grant, mortgage, license or other agreement affecting the rights and property herein conveyed has been or will be made to others by the undersigned, and that the full right to convey the same as herein expressed is possessed by the undersigned;

COVENANT that, when requested and at the expense of the Assignee, to carry out in good faith the intent and purpose of this assignment, the undersigned will execute all divisional, continuing, substitute, renewal, reissue, and all other patent applications on any and all such improvements; execute all rightful oaths, declarations, assignments, powers of attorney and other papers; communicate to the Assignee all facts known to the undersigned relating to such improvements and the history thereof; and generally do everything possible which the Assignee shall consider desirable for securing, maintaining and enforcing proper patent protection for such improvements and for vesting title to such improvements in the Assignee;

PATENT
OPTV-187/PRV/US

COVENANT AND AGREE that the above is and will be binding on the heirs, assigns, representatives and successors of the undersigned and extend to the successors, assigns and nominees of the Assignee.

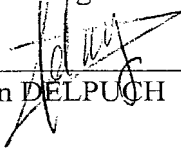
Inventor Signature  Date: 27 August 2002
Name: Alain DELPUCH

Inventor Signature _____ Date: _____
Name: James WHITLEDGE

Inventor Signature _____ Date: _____
Name: Jean-Rene MENAND

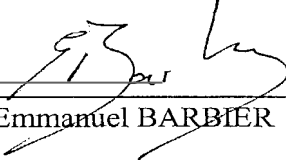
Inventor Signature  Date: 27 August 2002
Name: Emmanuel BARBIER

Inventor Signature _____ Date: _____
Name: Kevin HAUSMAN

Inventor Signature _____ Date: _____
Name: Debra HENSGEN

Inventor Signature _____ Date: _____
Name: Dongmin SU



UNITED STATES PATENT AND TRADEMARK OFFICE

UNITED STATES DEPARTMENT OF COMMERCE
 United States Patent and Trademark Office
 Address: COMMISSIONER FOR PATENTS
 P.O. Box 1450
 Alexandria, Virginia 22313-1450
 www.uspto.gov



Bib Data Sheet

CONFIRMATION NO. 2305

SERIAL NUMBER 10/419,621	FILING OR 371(c) DATE 04/21/2003 RULE 1.47	CLASS 725	GROUP ART UNIT 2611	ATTORNEY DOCKET NO. 5266-06201
------------------------------------	--	---------------------	-------------------------------	--

APPLICANTS

Alain Delpuch, Les Essarts Le Roi, FRANCE;
 James Whitledge, Naperville, IL;
 Jean-Rene Menand, Los Altos, CA;
 Emmanuel Barbier, Paris, FRANCE;
 Kevin Hausman, Naperville, IL;
 Debra Hensgen, Redwood City, CA;
 Dongmin Su, Santa Clara, CA;

**** CONTINUING DATA *******

This appln claims benefit of 60/373,883 04/19/2002

**** FOREIGN APPLICATIONS *******

IF REQUIRED, FOREIGN FILING LICENSE GRANTED **

06/17/2003

Foreign Priority claimed <input type="checkbox"/> yes <input type="checkbox"/> no	STATE OR COUNTRY	SHEETS DRAWING	TOTAL CLAIMS	INDEPENDENT CLAIMS
35 USC 119 (a-d) conditions met <input type="checkbox"/> yes <input type="checkbox"/> no <input type="checkbox"/> Met after Allowance	FRANCE	5	23	4
Verified and Acknowledged <u>Examiner's Signature</u> <u>Initials</u>				

ADDRESS

35690

TITLE

Supporting common interactive television functionality through presentation engine syntax

FILING FEE RECEIVED 1018	FEES: Authority has been given in Paper No. _____ to charge/credit DEPOSIT ACCOUNT No. _____ for following:	<input type="checkbox"/> All Fees <input type="checkbox"/> 1.16 Fees (Filing) <input type="checkbox"/> 1.17 Fees (Processing Ext. of time) <input type="checkbox"/> 1.18 Fees (Issue) <input type="checkbox"/> Other _____ <input type="checkbox"/> Credit
------------------------------------	---	---

PATENT APPLICATION SERIAL NO. _____

U.S. DEPARTMENT OF COMMERCE
PATENT AND TRADEMARK OFFICE
FEE RECORD SHEET

04/23/2003 SMINASS1 00000092 501505 10419621

01 FC:1001	750.00 CH
02 FC:1202	54.00 CH
03 FC:1201	84.00 CH

PATENT APPLICATION FEE DETERMINATION RECORD

Effective January 1, 2003

Application or Docket Number

10419621

CLAIMS AS FILED - PART I

	(Column 1)	(Column 2)
TOTAL CLAIMS	23	
FOR	NUMBER FILED	NUMBER EXTRA
TOTAL CHARGEABLE CLAIMS	23 minus 20 = *	3
INDEPENDENT CLAIMS	21 minus 3 = *	1
MULTIPLE DEPENDENT CLAIM PRESENT <input type="checkbox"/>		

SMALL ENTITY TYPE

OR OTHER THAN SMALL ENTITY

RATE	FEE
BASIC FEE	375.00
X\$ 9=	
X42=	
+140=	
TOTAL	

RATE	FEE
BASIC FEE	750.00
X\$18=	54
X84=	84
+280=	
TOTAL	288

* If the difference in column 1 is less than zero, enter "0" in column 2

CLAIMS AS AMENDED - PART II

	(Column 1)	(Column 2)	(Column 3)
AMENDMENT A	CLAIMS REMAINING AFTER AMENDMENT	HIGHEST NUMBER PREVIOUSLY PAID FOR	PRESENT EXTRA
	Total *	Minus **	=
	Independent *	Minus ***	=
FIRST PRESENTATION OF MULTIPLE DEPENDENT CLAIM <input type="checkbox"/>			

SMALL ENTITY

OR OTHER THAN SMALL ENTITY

RATE	ADDITIONAL FEE
X\$ 9=	
X42=	
+140=	
TOTAL ADDIT. FEE	

RATE	ADDITIONAL FEE
X\$18=	
X84=	
+280=	
TOTAL ADDIT. FEE	

	(Column 1)	(Column 2)	(Column 3)
AMENDMENT B	CLAIMS REMAINING AFTER AMENDMENT	HIGHEST NUMBER PREVIOUSLY PAID FOR	PRESENT EXTRA
	Total *	Minus **	=
	Independent *	Minus ***	=
FIRST PRESENTATION OF MULTIPLE DEPENDENT CLAIM <input type="checkbox"/>			

RATE	ADDITIONAL FEE
X\$ 9=	
X42=	
+140=	
TOTAL ADDIT. FEE	

RATE	ADDITIONAL FEE
X\$18=	
X84=	
+280=	
TOTAL ADDIT. FEE	

	(Column 1)	(Column 2)	(Column 3)
AMENDMENT C	CLAIMS REMAINING AFTER AMENDMENT	HIGHEST NUMBER PREVIOUSLY PAID FOR	PRESENT EXTRA
	Total *	Minus **	=
	Independent *	Minus ***	=
FIRST PRESENTATION OF MULTIPLE DEPENDENT CLAIM <input type="checkbox"/>			

RATE	ADDITIONAL FEE
X\$ 9=	
X42=	
+140=	
TOTAL ADDIT. FEE	

RATE	ADDITIONAL FEE
X\$18=	
X84=	
+280=	
TOTAL ADDIT. FEE	

* If the entry in column 1 is less than the entry in column 2, write "0" in column 3.

** If the "Highest Number Previously Paid For" IN THIS SPACE is less than 20, enter "20."

***If the "Highest Number Previously Paid For" IN THIS SPACE is less than 3, enter "3."

The "Highest Number Previously Paid For" (Total or Independent) is the highest number found in the appropriate box in column 1.

CLAIMS ONLY

SERIAL NO.

FILING DATE

APPLICANT(S)

CLAIMS

	AS FILED		AFTER 1st AMENDMENT		AFTER 2nd AMENDMENT	
	IND.	DEP.	IND.	DEP.	IND.	DEP.
1						
2						
3						
4						
5						
6						
7						
8						
9						
10						
11						
12						
13						
14						
15						
16						
17						
18						
19						
20						
21						
22						
23						
24						
25						
26						
27						
28						
29						
30						
31						
32						
33						
34						
35						
36						
37						
38						
39						
40						
41						
42						
43						
44						
45						
46						
47						
48						
49						
50						
TOTAL IND.						
TOTAL DEP.						
TOTAL CLAIMS						

	*		*		*	
	IND.	DEP.	IND.	DEP.	IND.	DEP.
51						
52						
53						
54						
55						
56						
57						
58						
59						
60						
61						
62						
63						
64						
65						
66						
67						
68						
69						
70						
71						
72						
73						
74						
75						
76						
77						
78						
79						
80						
81						
82						
83						
84						
85						
86						
87						
88						
89						
90						
91						
92						
93						
94						
95						
96						
97						
98						
99						
100						
TOTAL IND.						
TOTAL DEP.						
TOTAL CLAIMS						

* MAY BE USED FOR ADDITIONAL CLAIMS OR ADMENDMENTS

UNITED STATES PATENT AND TRADEMARK OFFICE

UNITED STATES DEPARTMENT OF COMMERCE
 United States Patent and Trademark Office
 Address: COMMISSIONER OF PATENTS AND TRADEMARKS
 P.O. Box 1450
 Alexandria, Virginia 22313-1450
 www.uspto.gov

APPLICATION NUMBER	FILING/RECEIPT DATE	FIRST NAMED APPLICANT	ATTORNEY DOCKET NUMBER
10/419,621	04/21/2003	Alain Delpuch	5266-06201

CONFIRMATION NO. 2305

35690
 MEYERTONS, HOOD, KIVLIN, KOWERT & GOETZEL, P.C.
 P.O. BOX 398
 AUSTIN, TX 78767-0398

FORMALITIES LETTER

OC000000010286898

Date Mailed: 06/18/2003

NOTICE TO FILE MISSING PARTS OF NONPROVISIONAL APPLICATION

FILED UNDER 37 CFR 1.53(b)

Filing Date Granted
Items Required To Avoid Abandonment:

An application number and filing date have been accorded to this application. The item(s) indicated below, however, are missing. Applicant is given **TWO MONTHS** from the date of this Notice within which to file all required items and pay any fees required below to avoid abandonment. Extensions of time may be obtained by filing a petition accompanied by the extension fee under the provisions of 37 CFR 1.136(a).

- The oath or declaration is missing.
A properly signed oath or declaration in compliance with 37 CFR 1.63, identifying the application by the above Application Number and Filing Date, is required.
- To avoid abandonment, a late filing fee or oath or declaration surcharge as set forth in 37 CFR 1.16(e) of \$130 for a non-small entity, must be submitted with the missing items identified in this letter.

SUMMARY OF FEES DUE:

Total additional fee(s) required for this application is **\$130** for a Large Entity

- **\$130** Late oath or declaration Surcharge.

*A copy of this notice **MUST** be returned with the reply.*

Customer Service Center
 Initial Patent Examination Division (703) 308-1202

PART 3 - OFFICE COPY



26 1178

IN THE UNITED STATES PATENT AND TRADEMARK OFFICE

In re Application of:
Delpuch et al.

Serial No. 10/419,621

Filed: April 21, 2003

For: Supporting Common Interactive
Television Functionality Through
Presentation Engine Syntax

§
§
§
§
§
§
§
§
§
§
§
§

Group Art Unit: 2611
Examiner: Unknown

Atty. Dkt. No. 5266-06201

I hereby certify that this correspondence is being deposited with the U.S. Postal Service as First Class Mail in an envelope addressed to: Commissioner for Patents, P.O. Box 1450, Alexandria, VA 22313-1450, on the date indicated below:	
Rory D. Rankin Registered Representative	
8/1/03 Date	_____ Signature

INFORMATION DISCLOSURE STATEMENT

RECEIVED

Commissioner for Patents
P.O. Box 1450
Alexandria, VA 22313-1450

AUG 06 2003

Technology Center 2600

Sir:

Applicant requests consideration of the references listed on the attached Form PTO-1449 and/or the additional information identified below in paragraph 3.

- A copy of each reference listed on the Form PTO-1449 is enclosed.
- The references listed on the Form PTO-1449 were previously cited in application serial no. _____ to which the captioned application is seeking priority under 35 U.S.C. §120; therefore, a copy of each reference is not enclosed.

1. This Information Disclosure Statement is submitted:

- a. within 3 months of the filing date of a national application other than a continued prosecution application under § 1.53(d);
- within 3 months of the date of entry of the national stage as set forth in § 1.491 in an International application;
- before the mailing date of a first Office Action on the merits; or
- before the mailing of a first Office Action after the filing of a request for continued examination under § 1.114.
- b. after the events of above paragraph 1a and prior to the mailing date of a final Office Action or Notice of Allowance, and thus: the certification of paragraph 2 below is provided, or a fee of \$180.00 is enclosed.

- c. after the mailing date of a final Office Action or a Notice of Allowance and prior to payment of the issue fee, and thus: the certification of paragraph 2 below is provided and a fee of \$180.00 is enclosed.
2. It is hereby certified:
- that each item of information contained in this Information Disclosure Statement was cited in a communication from a foreign patent office in a counterpart foreign application not more than three months prior to the filing of the Statement, or
- that no item of information contained in the Information Disclosure Statement was cited in a communication from a foreign patent office in a counterpart foreign application or, to the knowledge of the person signing the certification after making reasonable inquiry, was known to any individual designated in § 1.56 (c) more than three months prior to the filing of the Statement.
3. Consideration of the following additional information (including any co-pending or abandoned U.S. applications, prior uses and/or sales, etc.) is requested:
4. For each non-English language reference listed on the attached Form PTO-1449:
- reference is made to an English language translation submitted herewith, and/or
- reference is made to a foreign patent office search report (in the English language) submitted herewith, and/or
- reference is made to an English language translation of a foreign patent office search report submitted herewith, and/or
- reference is made to the concise explanation contained in the specification of the present application at page(s) _____, and/or
- reference is made to the concise explanation set forth below:
5. Applicant also offers the following comments for the Examiner's consideration:
6. Also enclosed is a copy of a foreign search report citing these references.
7. The listed documents were brought to the attention of the Applicant(s) after payment of the issue fee in the captioned case. The documents were cited in a communication from a foreign patent office in a counterpart foreign application not more than three months prior to the filing of this Information Disclosure Statement. Applicant(s) request this Information Disclosure Statement and attached Form PTO-1449 be placed in the file of the captioned application.
8. Applicant(s) requests that the Information Disclosure Statement and attached Form PTO-1449 and references, which are being filed before the grant of the

patent and pursuant to 37 C.F.R. § 1.97(i), be placed in the file of the captioned application.

If any required fees are missing, the Commissioner is authorized to charge said fees to Meyertons, Hood, Kivlin, Kowert & Goetzl, P.C. Deposit Account No. 501505/5266-06201/RDR.

Respectfully submitted,



Rory D. Rankin
Reg. No. 47,884
Attorney for Applicant(s)

MEYERTONS, HOOD, KIVLIN,
KOWERT & GOETZEL, P.C.

P. O. Box 398
Austin, Texas 78767
(512) 853-8800

Date: 8/1/03

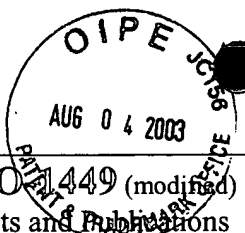

Form PTO 1449 (modified) List of Patents and Publications For Applicant's Information Disclosure Statement (Use several sheets if necessary)	ATTY. DKT. NO. 5266-06201 APPLICANT: Delpuch et al. FILING DATE: April 21, 2003	SERIAL NO. 10/419,621 GROUP: 2611
---	--	--

U.S. PATENT DOCUMENTS

EXAM. INITIALS	REF. DES.	DOCUMENT NUMBER	DATE	NAME	CLASS	SUB CLASS	FILING DATE APPROPRIAT
	A1	6,184,878	02/06/2001	Alonso et al.			

RECEIVED
AUG 06 2003
 Technology Center 2600

FOREIGN PATENT DOCUMENTS

EXAM. INITIALS	REF. DES.	DOCUMENT NUMBER	DATE	COUNTRY	CLASS	SUB CLASS	TRANSLATIO YES/NO
	A2	WO 02/17639 A2	28/02/2002	PCT			
	A3	2 332 803	03/06/1999	GB			
	A4	0 839 599 A2	22/04/1998	EP			

OTHER ART (Including Author, Title, Date, Pertinent Pages, Etc.)

	A5	International Search Report; PCT/US 03/12241; Mailed 07/07/2003					

EXAMINER: _____ **DATE CONSIDERED:** _____

EXAMINER: Initial if citation considered, whether or not citation is in conformance with MPEP 609; Draw line through citation if not in conformance and not considered. Include copy of this form with next communication to the patent owner.

A2

(19) World Intellectual Property Organization
International Bureau



(43) International Publication Date
28 February 2002 (28.02.2002)

PCT

(10) International Publication Number
WO 02/17639 A2

(51) International Patent Classification⁷: H04N 7/173

O. [US/US]; 3031 E. Wycliff Way, Highlands Ranch, CO 80126 (US).

(21) International Application Number: PCT/US01/26369

(74) Agents: GALLENSON, Mavis, S. et al.; 5670 Wilshire Blvd. Suite 2100, Los Angeles, CA 90036 (US).

(22) International Filing Date: 21 August 2001 (21.08.2001)

(25) Filing Language: English

(81) Designated States (*national*): AE, AG, AL, AM, AT, AU, AZ, BA, BB, BG, BR, BY, BZ, CA, CH, CN, CO, CR, CU, CZ, DE, DK, DM, DZ, EC, EE, ES, FI, GB, GD, GE, GH, GM, HR, HU, ID, IL, IN, IS, JP, KE, KG, KP, KR, KZ, LC, LK, LR, LS, LT, LU, LV, MA, MD, MG, MK, MN, MW, MX, MZ, NO, NZ, PH, PL, PT, RO, RU, SD, SE, SG, SI, SK, SL, TJ, TM, TR, TT, TZ, UA, UG, US, UZ, VN, YU, ZA, ZW.

(26) Publication Language: English

(30) Priority Data:
60/227,063 21 August 2000 (21.08.2000) US
09/933,927 21 August 2001 (21.08.2001) US

(71) Applicant (*for all designated States except US*): INTEL-LOCITY USA, INC. [US/US]; 1400 Market Street, Denver, CO 80202 (US).

(84) Designated States (*regional*): ARIPO patent (GH, GM, KE, LS, MW, MZ, SD, SL, SZ, TZ, UG, ZW), Eurasian patent (AM, AZ, BY, KG, KZ, MD, RU, TJ, TM), European patent (AT, BE, CH, CY, DE, DK, ES, FI, FR, GB, GR, IE, IT, LU, MC, NL, PT, SE, TR), OAPI patent (BF, BJ, CF,

(72) Inventor; and

(75) Inventor/Applicant (*for US only*): MARKEL, Steven,

[Continued on next page]

(54) Title: SYSTEM AND METHOD FOR TELEVISION ENHANCEMENT

Set Top Box Models

100

Mitsubishi WB-2001
Philips Magnavox MAT972
Philips Magnavox MAT976
RCA RW2110
Sony INT-W250
Sony INT-W200

HTML Support

HTML 1.0
HTML 2.0
HTML 3.2
Frames Compatibility
JavaScript 1.2

102

Image Support

GIF89a animation
JPEG
Progressive JPEG
PNG
TIFF-G3 Fax in Email
X bitmap
Macromedia™ Flash 1.0
Macromedia™ Flash 2.0
Macromedia™ Flash 3.0
Transaction

104

(57) Abstract: A text based script file describing enhancements is parsed to produce platform dependent enhancement files that may be employed to produce enhancements on a set topbox, enhanced television, or computer display. A script file may be of XML format and a parser may be an XSL translator. A parser may import HTML and Javascript from other applications. A parser may support a media player for emulation to view video and enhancements. Trigger data for rendering enhancements may be formatted into a javascript array. Trigger events may be employed to replace graphic pointers or text values. Multiple parsers, each supporting a specific platform, allow a single script file to be employed across multiple platforms. New platforms or versions of platforms are supported through new or updated parsers.



WO 02/17639 A2

GA

WO 02/17639 A2



CG, CI, CM, GA, GN, GQ, GW, ML, MR, NE, SN, TD, TG).

For two-letter codes and other abbreviations, refer to the "Guidance Notes on Codes and Abbreviations" appearing at the beginning of each regular issue of the PCT Gazette.

Published:

— *without international search report and to be republished upon receipt of that report*

SYSTEM AND METHOD FOR TELEVISION ENHANCEMENT

Cross Reference to Related Applications

5
This application is based upon and claims priority of United States provisional application number 60/227,063 entitled "A DATA DRIVEN SYSTEM AND METHOD FOR DISTRIBUTION OF INTERACTIVE CONTENT TO MULTIPLE TARGETTED PRESENTATION PLATFORMS", filed August 21, 2000 by Steve O. Markel, the entire
10 disclosure of which is herein specifically incorporated by reference for all that it discloses and teaches.

Backgrounda. Field

The present disclosure relates to interactive and enhanced television and, more particularly, to a method and system that produces enhanced content that may be employed across a plurality of platforms without re-editing. In greater detail this disclosure discusses systems and methods for distribution of interactive content to multiple targeted presentation platforms.

20 b. Description of the Background

A television program may be accompanied by additional information employed to enhance the program or to provide viewer interaction. Enhancements have historically included closed captioning and multilingual support. Advances in networking, computer
25 systems, and video production have increased the number and types of enhancements that may be provided with a program or advertisement. Enhancements may include stock updates, news stories, Internet links, weather forecasts, bulletins, statistics, trivia, and other information. For example, a football game may include icons allowing viewing of team players, statistics, trivia and other information such as upcoming games. Further, the
30 advent of set-top-boxes, as may be used in cable and satellite television systems, allows enhancement information to be presented in new ways, such as screen overlays and in windows, for example.

Enhanced television content may employ a combination of HTML (hypertext markup language), JavaScript, Java and other formats common to Internet page display. An enhanced display may comprise text, icons, graphics and images placed at locations on or in proximity to the television image. To produce an enhanced display, an author
5 must create a file identifying each displayed element (such as text, icons, graphics and images), the location where each element is displayed and the time at which the element may be displayed. Due to numerous differences between presentation platforms, such as set top boxes, satellite receivers, computers, or interactive televisions, for example, content providers have historically been required to select a specific platform in the
10 development of an enhancement application. In order to provide support for each additional platform, the interactive content provider must introduce potentially significant modifications to the existing application, resulting in the ongoing maintenance of multiple code bases, and adding to the time and cost required producing enhanced page layouts for multiple platforms.

15 Additionally, previous methods employed to enter parameters required to generate and position the elements comprising the layout of enhanced pages have involved significant manually entry. Manual editing of an enhancement file may also introduced unintended changes such that enhancements are not uniform across platforms. Therefore a new method of creating enhanced content that allows utilization across multiple
20 platforms and provides an accurate preview of enhancements is needed.

Summary of the Invention

The present invention overcomes the disadvantages and limitations of the prior art by
25 providing a system and method that parses a text based script enhancement file to provide emulation of enhancements and to provide output of platform specific enhancement files. The enhancement file, which may employ an XML format, contains a description of enhancements including element position, attributes, triggering and linkage. Linkage associates a file with an element such that a user may select a linked object to access
30 websites, launch other applications, or to perform other tasks. Parsing the enhancement file produces an output file targeted to a specific platform. The platform may comprise a

set top box, interactive television or computer display. A file parsed for computer display may be employed for emulation and preview of enhancements and may contain functions for control of a browser media player.

The invention therefore may comprise a method for creating a television presentation enhancement comprising accessing a platform independent enhancement file
5 containing elements and attributes of the elements, applying a first parsing script to the enhancement file to produce a first output file that may be viewed using a web browser and media player, and applying a second parsing script to the enhancement file to produce a second output file that may be viewed with a set top box.

10 An enhancement file of XML format may be parsed using XSL (Extensible Stylesheet Language) scripts. In the present invention, an XML file with tags for administrative information, layout information, and trigger information is employed. The XML file may be parsed to produce an output file containing HTML and JavaScript code wherein the version of HTML and Javascript reflect the level of support provided by the
15 target platform. Further, the output file may be formatted for a mode of enhancement transport. In a first mode of transport, enhancements and triggers are supplied in conjunction with a video program. In a second transport mode, triggers and a locator, such as a URL, are provided in conjunction with a video program and the platform employs the locator to access enhancement information.

20 The invention may further comprise a system for developing television enhancements comprising a computer; a database; a web browser; and a parser operable to parse a platform independent enhancement file contained in the database and to produce an output that may be viewed employing the browser.

25 Advantageously, the invention provides viewing and emulation of enhancement files employing a personal computer or similar equipment. This allows a team of developers and reviewers to be physically separated, and allows enhancement customers (such as advertisers) to preview material by simply accessing a website.

Description of the Figures

In the figures,

5 Figure 1 depicts html and image support for a group of commercially available set top box products.

Figure 2 depicts the software environment of the present invention.

Figure 3 is an overview flowchart of parsing an XML file to emulate and preview enhancements.

Figure 4 depicts a first flowchart of part of a parsing process.

10 Figure 5 depicts a second flowchart of a parsing process.

Figure 6 depicts a third flowchart of a parsing process.

Figure 7 depicts a computer display of an enhancement.

Detailed Description of the Invention

15

Enhanced television content is typically presented using a combination of HTML, JavaScript, Java and other web technologies. The level of support for these technologies varies by the targeted presentation platform, including the combination of client hardware, operating system, web browser and add-on software. A presentation platform
20 comprises a set top box, interactive television, computer, or other system operable to receive television signals and to process HTML and other code and to produce a display comprising a television image and enhancements. Capabilities vary depending the specific platform. Certain functions may or may not exist, or may be optimized on a given platform through the use of custom features. Variants include screen size and
25 resolution, acceptable color combinations, graphics support, and version of HTML or JavaScript, for example. Providing concurrent support for the Internet or wireless handheld devices introduces additional requirements and dependencies. The present invention overcomes the difficulties of supporting multiple platforms, each having a specific set of capabilities, by employing a platform independent text based script file that
30 completely defines the enhancement assets, their location and other attributes, as well as the triggering information. The text based script file is then translated by parsing software to produce platform dependent files comprising HTML and JavaScript code tailored to

the specific platform. The present invention also allows translation targeting a web browser and a media player, providing emulation and preview of authored enhancements.

Figure 1 depicts HTML and image support for a group of commercially available set top box products. Set top box models 100 provide HTML support 102 and image support 104. HTML support 102 lists support for html 1.0, 2.0, and 3.2 versions. A limitation of HTML is that some versions lack downward compatibility. For example, HTML versions 4 and higher do not support all the tags of HTML 3.2. Figure 1 serves to illustrate that an HTML based author for creating enhanced content would not be able to support a wide range of target platforms. The present invention overcomes the disadvantages of HTML based authoring by employing an authoring tool that generates an XML file that may be parsed using XSL scripts for each platform type to produce HTML code and JavaScript suitable for each platform.

Figure 2 depicts the environment of the present invention. Environment 200 comprises database 208 containing user and project administration information 202, page layout information 204 and trigger creation information 206. XML file 210 is created using information from database 208. Import XSL's 212 may be employed to translate HTML and JavaScript into XML file 210. Emulator XSL 214 provides translation of XML file 210 into HTML and JavaScript, plus provides media player controls for emulation and preview. STB Agnostic Sniffer XSL 216 includes platform query routines to determine the type of platform requesting enhancement information. WebTV™ XSL 218 provides translation compatible with WebTV platforms. AOLTV™ XSL 220 provides translation compatible with AOLTV platforms. Triggers XSL 222 provides triggers that may be transmitted with a television presentation that may be used to synchronize display of enhancements. Enhancement information may be transmitted with the television presentation, or may be accessed by the platform in response to the trigger information. Translated files may be stored in server 224.

Figure 3 is an overview flowchart of parsing an XML file to emulate and preview enhancements. Process steps shown in figure 3 are described in greater detail in following figures. Parsing process 300 starts with step 302 where comments are inserted that indicate the project name, page names, date, time, and other information. This information will form in part, the header of the resultant HTML/JavaScript file produced

by the parsing process. At step 304, a list of elements comprising an enhancement is scanned and checked for a JavaScript tag. If a JavaScript tag is found, the JavaScript is placed into the output file. At step 306, trigger tags are extracted, trigger data is sorted and a JavaScript trigger array is created that comprises time, element, and new element value. This array is referenced during emulation. At step 308, the list of elements is scanned and a function to change the text value is generated for elements with a text area tag. This function allows text in a text area to be changed, such as response to a trigger event. At step 310, the list of elements is scanned and a function to change the source value is applied to graphics elements. At step 312, code that references the trigger array and individual function is inserted. At step 314, code is inserted that is executed when the browser window is opened. At step 316, the list of elements is scanned and if an imported HTML tag element is found, the value is extracted and placed in the output file. At step 318, code supporting a media player including stop, go, pause, and timer is written to the output file. At step 320, a media player object is placed in the output file if a 'TV' object is present in the XML source file. Graphics elements are placed in the output file with 'img' tags and text elements are placed in the output file with text tags. A web browser may access the output file created by the above parsing process and the enhancement may be displayed. If the enhancements are related to a television image, the media player module allows viewing in conjunction with display of a video image. The module allows the media player to present a video sequence, along with enhancements. The media player may be paused, stopped, started, or the user may go to a specific frame or display time. The following figures provide a more detailed description of the steps employed in parsing an XML source file.

Figure 4 depicts a first flowchart of part of a parsing process. Process 400 starts at step 402 where a looped process for each page of the XML file begins. Page loop 404 provides a return path for the process when an additional page or pages remain. At step 406, <HTML> and <HEAD> open tags are written. At step 408 a <TITLE> tag is written with the page name. At step 410, ownership and contact comment information may be written. At step 412, a project name comment may be written. At step 414, a page name comment may be written. At step 416, an author comment may be written. At step 418, a comment indicating the date the XML file was authored may be written. At step 420, a

notes comment may be written. At step 422 a JavaScript tagging process begins. At step 424, an element is accessed from the XML file and is checked to determine if the element is of import type. If the element is not of import type, processing returns to step 422 where another element is accessed. If all elements have been accessed, processing
5 continues at step 434. If the result of step 424 is that the accessed element is of import type, step 426 writes a language specification indicating that the script language is JavaScript. At step 428, the contents within the 'js' tag of the XML file are written. At step 430, a "</script>" closing tag is written. At step 432, processing continues to step 422 to access additional elements. If all elements have been accessed, processing
10 continues at step 434. At step 434 JavaScript variable statements for trigger emulation are written. At step 436, an opening tag for an array of triggers is written. At step 438 a processing loop is started. Step 438 accesses trigger information, ordered by time, each time the loop is executed. At step 440, the trigger time, multiplied by 1000, is written. At step 442, the element name affected by the trigger is written. At step 444, parameters
15 associated with each trigger are written. Step 446 checks if additional trigger information may be accessed for the current page. If additional information may be accessed, processing continues at step 438. When all trigger information has been accessed, processing continues at step 448 where a value indicating the end of the trigger array is written. Step 450 leads to the steps shown in figure 5.

20 Figure 5 depicts a second flowchart of a parsing process. Step 502 is a continuation from the steps shown in figure 4. At step 504, a processing loop accesses each element of the current page. Step 506 checks if the element is a text element. If the element is a text element, step 508 writes a function for changing the text value within the text area. Processing then continues with step 514. If step 506 determines that the
25 element is not a text element, step 510 checks if the element is a graphics element. If the element is a graphics element, step 528 writes a function for changing the source value within an image field. Processing then continues with step 503. If step 510 determines that the element is not a graphic element, processing continues at step 514. At step 514, processing continues at step 504 if additional elements remain. If all elements have been
30 accessed, processing continues at step 516. Step 516 writes a script closing tag. Step 518 then writes a script language tag indicating that the script language is JavaScript. Step

522 writes setup variables for a media player. Step 524 then converts numeric seconds to an ASCII string. Step 526 writes a function to handle start, stop and pause controls for the media player. Step 528 writes a function for time display. Time display may be used to indicate the time of a video sequence being shown by the media player. At step 530, event code for selection of the media player 'go' button is written. At step 532, event code the selection of the media player 'stop' button is written. At step 534, event code for selection of the media player 'preview' button is written. At step 536, event code is written that is executed when the emulation window is opened. At step 538 a closing script tag is written. At step 540, a closing head tag is written. Step 542 writes a 'body' tag with an event handler for window loading. Step 544 leads to the steps shown in figure 6.

Figure 6 depicts a third flowchart of a parsing process. Step 602 is a continuation from the steps shown in figure 5. At step 604, a processing loop accesses each element within each page. Step 606 checks if the element is of import type. If the element is not of import type, processing continues at step 604 where the next element is accessed. If all elements have been accessed, processing continues at step 616. If step 606 determines that the element is of import type, step 608 writes a division tag (<div>) and writes body code comprising element name, absolute position, top left position and z index. The z index value may be employed to control the order in which elements are rendered, causing one element to appear on top of another element. Step 610 writes the contents of the 'htmlBody' tag. Step 612 then writes an end <div> tag. At step 614, if all elements have not been accessed, processing continues at step 604. If all elements have been accessed, processing continues at step 616. Step 616 writes a division tag for media player positioning buttons. Step 618 writes <table> code with positioning buttons. Step 620 writes an end <div> tag, demarking the division started at step 616. At step 622, a processing loop accesses each element within each page. Step 624 checks if the element type is graphic. If the element is a graphic element, step 626 writes a division tag for html body code comprising element name, absolute position, top left position and z index. Step 628 checks if a URL (Universal Resource Locator) exists for the element. If a URL exists, step 630 writes a URL html tag. Step 632 then writes an 'img' tag with element name, border=0, and source. Source is the address of where the graphic element is stored. Processing then continues at step 644. If step 628 determines that a URL does not exist

for the element, step 632 writes an 'img' tag with element name, border=0, and source. Processing then continues at step 644. If step 624 determines that the element is not a graphics element, processing continues at step 634. Step 634 checks if the element is of type 'tv'. If the element is of type 'tv', step 636 writes a division tag for html body code comprising element name, absolute positioning, top left position, and z index. Step 638
5 writes code to embed a media player. Processing then continues at step 644. If step 634 determines that the element is not a 'tv' type element, processing continues to step 640 where a check is performed if the element is a text area element. If the element is a text area element, step 642 writes a division tag for html body code comprising element name,
10 absolute positioning, top left position, z index, font, color, and point size. Processing then continues at step 644. If step 640 determines that the element is not a text area element, processing continues at step 644. At step 644 processing loops back to step 622 if elements remain that have not been accessed. Otherwise, processing continues at step 646. If pages remain that have not been accessed, processing continues to step 648 where
15 the process loops back to step 404 of figure 4 to access the next page. If all pages have been accessed, step 650 writes closing <body><html> tags and the process ends at step 652.

Figure 7 depicts a computer display of an enhancement. A text based script file, employing an XML format, describing the elements employed to create the enhancement
20 depicted in figure 7 is listed in Appendix A. Appendix B lists an HTML file with JavaScript that has been produced from the code of Appendix A through the process described in figures 3 to 6. Appendix B includes section identifiers that relate the code sections to steps shown in figure 3.

In operation, a user logs into an editing system, creates a project, and then lays out
25 enhanced content pages and creates triggers for those pages. A database stores project information that comprises pages and triggers and may include project name, author date and other information. Information in the database is employed to create a text based script file that describes each element, its attributes, its layout and triggering of the element. In one embodiment of the present invention, an XML file is employed. This file
30 is output platform independent and completely defines the assets, their location and other attributes, as well as the triggering information necessary for the enhanced content

project. The XML file is then processed using one or more XSL rule based parsers that “translate” the XML file into another format, such as HTML 4.0 and Javascript 1.2, for example. As depicted in figure 2, XSL parsers are employed for emulation and for creating platform specific output files. Parsing of the enhancement file for a particular platform may include translation of color values. Some platforms do not display pure colors and as such a lookup table or translation algorithm may be employed to check a color value and to alter the color value. The process shown in figures 3 to 6 produces an HTML and Javascript output that may be run on an industry standard web browser and media player such as Microsoft Internet Explorer and Windows Media Player, both from Microsoft Corporation. Additional information regarding XSL may be obtained from the following books:

Title: Professional XSL

Authors: Kurt Cagle et al.

15 Publisher: Wrox Press Inc;

ISBN: 1861003579

Title: XSL Companion, The

Author: Neil Bradley

20 Publisher: Addison-Wesley Pub Co;

ISBN: 0201674874

The foregoing description provides a system and method that translates a platform independent enhancement file into platform dependent files without needing to change the authored enhancements, saving time and money and providing a uniformity of enhancement across multiple platforms. The steps shown in the figures need not be performed in the exact order shown. An XML file format has been employed in the described embodiment. Other formats, both public and proprietary, may be employed to describe enhancements and attributes of the elements comprising enhancements. Enhancement output files allow enhancement of a television broadcast that may employ various methods of delivering enhancement data. A first method transfers enhancement

data as part of the broadcast. A second method transfers a trigger and locator with the broadcast, and the set top box, or other platform, employs the locator to access enhancement information. The second method of transfer may further comprise receiving information identifying the type of platform requesting enhancement data (when the platform accesses the locator), and providing enhancement information suited to the requesting platform. A new or modified parser may be employed to support new platforms, or new versions of platforms. The new or modified parser then may be applied to a plurality of source enhancement files that need not be modified. In this manner, the present invention provides costs savings in supporting new platforms or new versions of platforms.

The foregoing description of the invention has been presented for purposes of illustration and description. It is not intended to be exhaustive or to limit the invention to the precise form disclosed, and other modifications and variations may be possible in light in the above teachings. The embodiment was chosen and described in order to best explain the principles of the invention and its practical application to thereby enable others skilled in the art to best utilize the invention in various embodiments and various modifications as are suited to the particular use contemplated. It is intended that the appended claims be construed to include other alternative embodiments of the invention except insofar as limited by the prior art.

Appendix A

```

15      <?xml version="1.0" ?>
      - <!-- Viziworx XML Schema 1.1
      -->
      - <project>
20      <emulate>True</emulate>
      <useWMP>False</useWMP>
      <pjName>demo project</pjName>
      <date>8/11/2000 1:14:09 PM</date>
      <author>Steve Markel</author>
25      <canvas>pal</canvas>
      <notes>simple one page enhancement</notes>
      - <pages>
      - <page>
      <pgName>index</pgName>
30      - <element>
      <elName>tv9</elName>
      <type>tv</type>
      <src />
      <top>0</top>
35      <left>0</left>
      <height>392</height>
      <width>523</width>
      <zOrder>-1</zOrder>
      <url />
40      <font />
      <color />
      <size />
      <rows>0</rows>
      <cols>0</cols>
45      </element>
      - <element>
      <elName>nav</elName>
      <type>graphic</type>
      <src>C:/viziworx/betaGraphics/nav.jpg</src>
50      <top>0</top>
      <left>519</left>
      <height>480</height>
      <width>121</width>
      <zOrder>1</zOrder>
55      <url />
      <font />
      <color />
    
```

```

    <size />
    <rows>-1</rows>
60    <cols>-1</cols>
    </element>
- <element>
    <elName>button1</elName>
    <type>graphic</type>
65    <src>C:/vizworx/betaGraphics/button1.jpg</src>
    <top>108</top>
    <left>530</left>
    <height>20</height>
    <width>97</width>
70    <zOrder>3</zOrder>
    <url />
    <font />
    <color />
    <size />
75    <rows>-1</rows>
    <cols>-1</cols>
    </element>
- <element>
    <elName>button2</elName>
80    <type>graphic</type>
    <src>C:/viziworx/betaGraphics/button2.jpg</src>
    <top>144</top>
    <left>526</left>
    <height>25</height>
85    <width>97</width>
    <zOrder>4</zOrder>
    <url />
    <font />
    <color />
90    <size />
    <rows>-1</rows>
    <cols>-1</cols>
    </element>
- <element>
95    <elName>button3</elName>
    <type>graphic</type>
    <src>C:/vizworx/betaGraphics/button3.jpg</src>
    <top>187</top>
    <left>525</left>
100    <height>19</height>
    <width>97</width>
```

```

    <zOrder>5</zOrder>
    <url />
    <font />
105   <color />
    <size />
    <rows>-1</rows>
    <cols>-1</cols>
    </element>
110 - <element>
    <elName>button4</elName>
    <type>graphic</type>
    <src>C:/viziworx/betaGraphics/button4.jpg</src>
    <top>221</top>
115   <left>528</left>
    <height>42</height>
    <width>97</width>
    <zOrder>6</zOrder>
    <url />
120   <font />
    <color />
    <size />
    <rows>-1</rows>
    <cols>-1</cols>
125   </element>
- <element>
    <elName>text</elName>
    <type>graphic</type>
    <src>C:/viziworx/betaGraphics/text.jpg</src>
130   <top>391</top>
    <left>0</left>
    <height>89</height>
    <width>521</width>
    <zOrder>2</zOrder>
135   <url />
    <font />
    <color />
    <size />
    <rows>-1</rows>
140   <cols>-1</cols>
    </element>
- <element>
    <elName>textarea8</elName>
    <type>ta</type>
145   <src />
```

```
150     <top>406</top>
        <left>84</left>
        <height>50</height>
        <width>438</width>
        <zOrder>9</zOrder>
        <url />
        <font>arial</font>
        <color>#000000</color>
        <size>normal</size>
155     <rows>5</rows>
        <cols>80</cols>
        </element>
- <element>
        <elName>localogo</elName>
160     <type>graphic</type>
        <src>C:/viziworx/betaGraphics/localogo.jpg</src>
        <top>408</top>
        <left>17</left>
        <height>51</height>
165     <width>55</width>
        <zOrder>7</zOrder>
        <url />
        <font />
        <color />
170     <size />
        <rows>-1</rows>
        <cols>-1</cols>
        </element>
- <element>
175     <elName>ad</elName>
        <type>graphic</type>
        <src>C:/viziworx/betaGraphics/ad.gif</src>
        <top>418</top>
        <left>522</left>
180     <height>29</height>
        <width>108</width>
        <zOrder>8</zOrder>
        <url />
        <font />
185     <color />
        <size />
        <rows>-1</rows>
        <cols>-1</cols>
        </element>
```

```
190     <triggers>
        <trigger>
        <time>2</time>
        <prop>txt</prop>
        <elName>textarea9</elName>
195     <param>the first prompt</param>
        </trigger>
        <trigger>
        <time>4</time>
        <prop>txt</prop>
200     <elName>textarea9</elName>
        <param>the second prompt</param>
        </trigger>
        <trigger>
        <time>6</time>
205     <prop>src</prop>
        <elName>ad</elName>
        <param>C:/viziworxTestfiles/betaGraphics/amazon.jpg</param>
        </trigger>
        <trigger>
210     <time>8</time>
        <prop>txt</prop>
        <elName>textarea9</elName>
        <param>the final prompt</param>
        </trigger>
215     </triggers>
        </page>
        </pages>
        </project>
```

Appendix B

220 This appendix shows code generated from the XML file listed in Appendix A employing
 a parser of the present invention. Steps shown in bold reference steps shown in figure 3.

225 **[Step 302]**

```

225 <html>
    <head>
    <title>index</title>
    <!--..... Emulation: index.htm .....-->
230 <!--Code generated by ViziWorx, Inc.-->
    <!--Please contact us at info@viziworx.com-->
    <!--...-->
    <!--Project Name: demo project-->
    <!--Page Name: index-->
235 <!--Author: Steve Markel-->
    <!--Date Authored: 8/11/2000 1:13:21 PM-->
    <!--Layout: -->
    <!--Notes: simple one page enhancement-->
    <!--...-->
240
  
```

[Step 304]

```

245 <!--(none) -->
  
```

[Step 306]

```

250 <script language="javascript">
    var timerDelta=50;
    var startCount=0;
    var timerID;
    var ms = 0;
    var iaT = 0;
    var pauseGo = 0;
255
    var aTriggers = new Array(
    260 2*1000, "textareas('the first prompt')",
    4*1000, "textareas('second prompt')",
    6*1000, "ad('C:/viziworx/betaGraphics/amazon.jpg')",
    8*1000, "textareas('final prompt')",
    99999999, "");
  
```

265 **[Steps 308 and 310]**

```

    function fnav(theImg) { document.all["nav"].src = theImg; }
    function fbutton1(theImg) { document.all["button1"].src =
270 theImg; }
    function fbutton2(theImg) { document.all["button2"].src =
    theImg; }
275 theImg; }
    function fbutton3(theImg) { document.all["button3"].src =
    theImg; }
    function fbutton4(theImg) { document.all["button4"].src =
    theImg; }
  
```

```

280         function ftext(theImg) { document.all["text"].src = theImg;
    }
    function ftextarea8(theTxt) { window.textarea8.innerText =
285 theTxt; }
    function flocaLogo(theImg) { document.all["localogo"].src =
theImg; }
290     function fad(theImg) { document.all["ad"].src = theImg; }
    </script>

[Step 312]
295 <script language="javascript">
<!--
var ms = 0;
var state = 0;
300 function __secs2asc(t) {
    var tSecs = Math.floor(t/1000);
    var hrs = Math.floor(tSecs/3600);
    var mins = Math.floor((tSecs-(hrs*3600)) / 60);
305 var secs = tSecs-((hrs*3600) + (mins*60));
    var ms = t % 1000;

    if(hrs>23) return "";
    if(hrs < 10) hrs = "0" + hrs;
310 if(mins < 10) mins = "0" + mins;
    if(secs < 10) secs = "0" + secs;
    if(ms < 10) ms = "00" + ms;
    if(ms < 100) ms = "0" + ms;
    if(ms == 0) ms = "000";
315 return hrs + ":" + mins + ":" + secs + "." + ms;
    }

function __startstop() {
320     if (state == 0) {
        ms = 0;
        state = 1;
        then = new Date();
        then.setTime(then.getTime() - ms);
        document.WMPPlay.Play();
325 window.__frmTr.__cmdMPGo.value="Pause";
    }
    else {
        state = 0;
        now = new Date();
330 ms = now.getTime() - then.getTime();
        window.lblTime.innerText = __secs2asc(ms);
        document.WMPPlay.Pause();
        window.__frmTr.__cmdMPGo.value="    Go
    }
335 }

function __timeDisplay() {
    timerID = setTimeout("__timeDisplay();", 50);
340     if (state == 1) {
        now = new Date();
        ms = now.getTime() - then.getTime();
        window.lblTime.innerText = __secs2asc(ms);
    }
}

```

```

    }
345 }

function __cmdMPGo_onclick() {
    if(timerID) clearTimeout(timerID);
    __timeDisplay();
350 __startstop();
    btnGo_onclick();
}

function __cmdMPStop_onclick() {
355 document.WMPlay.Stop();
    document.WMPlay.CurrentPosition = 0;
    state = 0;
    window.lblTime.innerText = __secs2asc(0);
    window.__frmTr.__cmdMPGo.value="    Go    ";
360 }

function Preview() {
    var func, ps, pe, param;
    if (aTriggers[iaT] <= ms) {
365     func = "F" + aTriggers[iaT+1];
        eval(func);
        iaT = iaT + 2;
    }
    ms = ms + timerDelta;
370 timerID = setTimeout("Preview()", timerDelta);
}

function btnStop_onclick() {
375     clearTimeout(timerID);
    pauseGo = 0;
}

function btnPause_onclick() {
380     if (pauseGo == 0) {
        btnStop();
        pauseGo = 1;
    }
    else {
385     Preview();
        pauseGo = 0;
    }
}

function btnGo_onclick() {
390     var offset;
    pauseGo = 0;
    for (ms=0,iaT=0; aTriggers[iaT] < ms; iaT=iaT+2) {}
    Preview();
395 }

[Step 314]

function window_onload() {
400     var p0 = document.body.innerHTML.lastIndexOf("<!--_sbody_-->");
    if(p0 > -1) {
        var p1 = document.body.innerHTML.indexOf("<![CDATA[", p0)+9;
        if(p1 > 8) { //if not, there was no imported html
            var s = "<DIV></DIV>]]&gt;";
405             var p2 = document.body.innerHTML.indexOf(s);
        }
    }
}

```

```

        var c1 = p2-p1;
        document.body.innerHTML =
410 document.body.innerHTML.substr(p1, c1) + "</div>" +
        document.body.innerHTML.substr(p2+s.length);
    }
}

window.__frmTr.__cmdMPGo.disabled=true;
window.__frmTr.__cmdMPStop.disabled=true;
415 document.WMPlay.FileName = "demo.asf";
document.WMPlay.ShowControls = false;
document.WMPlay.AutoStart = false;
window.__frmTr.__cmdMPGo.disabled=false;
window.__frmTr.__cmdMPStop.disabled=false;
420 }

-->
</script>
</head>
425

[Step 316]

<!-- none -->
430

[Step 318]

<body LANGUAGE="javascript" onload="return window_onload()">
<!--__stbody__-->
435 <div id="__divTr" style="position:absolute; top:500; left:0; z-index:0">
<form id="__frmTr" name="__frmTr">
<table border="0">
<tr>
<td>
440 <INPUT type="button" value="Go" id="__cmdMPGo" name="__cmdMPGo"
LANGUAGE="javascript" onclick="return __cmdMPGo_onclick()" />
<INPUT type="button" value="Stop" id="__cmdMPStop" name="__cmdMPStop"
LANGUAGE="javascript" onclick="return __cmdMPStop_onclick()" />
</td>
445 <td style="COLOR: #ff0000; FONT-FAMILY: Verdana; FONT-SIZE: 10pt; FONT-WEIGHT:
bold" bgcolor="#000000">
<LABEL name="lblTime" id="lblTime">00:00:00.000</LABEL>
</td>
</tr>
450 </table>
</form>
</div>

455 [Step 320]

<div id="tv9" style="position:absolute; top:0; left:0; z-index:-1">
<OBJECT codebase="CLSID:22D6F312-B0F6-11D0-94AB-0080C74C7E95"
classid="http://activex.microsoft.com/activex/controls/mplayer/en/nsmp2inf.cab#
460 Version=6,4,5,715" id="WMPlay" type="application/x-oleobject" id="WMPlay"
height="392" width="523" standby="Loading Microsoft Windows Media Player
components...">
<EMBED type="application/x-mplayer2" filename="demo.asf" displaysize="4"
name="WMPlay" width="523" height="392" />
465 </OBJECT>
</div>
<div id="divnav" style="position:absolute; top:0; left:519; z-index:1" href="">

```

```
</div>
470 <div id="divbutton1" style="position:absolute; top:108; left:530; z-index:3"
href="">

</div>
475 <div id="divbutton2" style="position:absolute; top:144; left:526; z-index:4"
href="">

</div>
480 <div id="divbutton3" style="position:absolute; top:187; left:525; z-index:5"
href="">

</div>
485 <div id="divbutton4" style="position:absolute; top:221; left:528; z-index:6"
href="">

</div>
490 <div id="divtext" style="position:absolute; top:391; left:0; z-index:2"
href="">

</div>
495 <div id="textarea8" style="position:absolute; top:406; left:84; width:438;
height:50; color:#000000; font-size:normal; font-family:arial; z-index:9">

Preview Text Area

</div>
500 <div id="divlocalogo" style="position:absolute; top:408; left:17; z-index:7"
href="">

</div>
505 <div id="divad" style="position:absolute; top:418; left:522; z-index:8"
href="">

</div>
</body>
510 </html>
```

Claims

What is claimed is:

1. A method of television enhancement produced by the steps of:
 - using a platform independent television enhancement file comprising elements and attributes of said elements; and
 - parsing said television enhancement file to produce an output file that may be viewed with a specific platform.
2. The method of claim 1 wherein said platform independent television is contained in a database and in said using step, the term using means accessing, said method further comprising the step of saving said output file.
3. The method of claim 1 wherein said method for creating said television enhancement is a presentation, said term using means accessing, said parsing step comprising:
 - applying a first parsing script to said enhancement file to produce a first output file that may be viewed using a web browser and media player; and
 - applying a second parsing script to said enhancement file to produce a second output file that may be viewed with a set top box.
4. The method of claim 1 wherein in the step of using, the term using means editing such that said editing specifies said elements and attributes, said method being for creating a television enhancement presentation, said parsing step comprising:

applying a first parsing script to said enhancement file to produce a first output file that may be viewed using a web browser and media player; and

applying a second parsing script to said enhancement file to produce a second output file that may be viewed with a set top box.

5. The method of claim 3 wherein said enhancement file further comprises:
XML compliant tags for elements, triggers, and administrative information comprising enhancement file name and enhancement file creation date.
6. The method of claim 3 wherein said television enhancement file is a text file.
7. The method of claim 3 further comprising:
displaying said first output file in a browser window.
8. The method of claim 3 wherein said step of applying a second parsing script further comprises:
specifying an HTML version for said second output file.
9. The method of claim 3 wherein a link is associated with at least one of said elements.
10. The method of claim 3 wherein said attributes of said elements further comprises:
a z order value for at least one of said elements.

11. The method of claim 3 wherein said first parsing script is an XSL transformation file.
12. The method of claim 3 wherein said second parsing script is an XSL transformation file.
13. The method of claim 3 further comprising:
storing said second output file.
14. The method of claim 3 wherein said second parsing script imports HTML code into said second output file.
15. The method of claim 3 wherein accessing said enhancement file further comprises:
accessing a database.
16. The method of claim 3 wherein said second parsing script is operable to translate a color value.
17. The method of claim 1 or 2 wherein said enhancement file is XML compliant.
18. The method of claim 17 wherein said step of parsing further comprises:
applying an XSL transformation to said enhancement file.
19. The method of claim 17 wherein said step of parsing further comprises:
translating a color value associated with one of said elements.

20. A system for developing television enhancements comprising:

a computer;

a database;

a web browser; and

a parser operable to parse a platform independent television enhancement file contained in said database and to produce an output file that may be viewed employing said browser.

21. The system of claim 20 further comprising:

a parser component operable to enable display of a media player if said television enhancement file contains an element representative of a television image.

22. The system of claim 20 wherein said parser is operable to create an output file for a specific platform.

23. The system of claim 20 wherein said parser is operable to translate a color value associated with an element contained in said television enhancement file.

24. A parser for producing a platform specific television enhancement file comprising:

a function to access a platform independent television enhancement file comprising project information, a description of an element, the position of said element, and a time at which said element may be rendered.

a function to create an HTML header containing said project information;

Figure 1

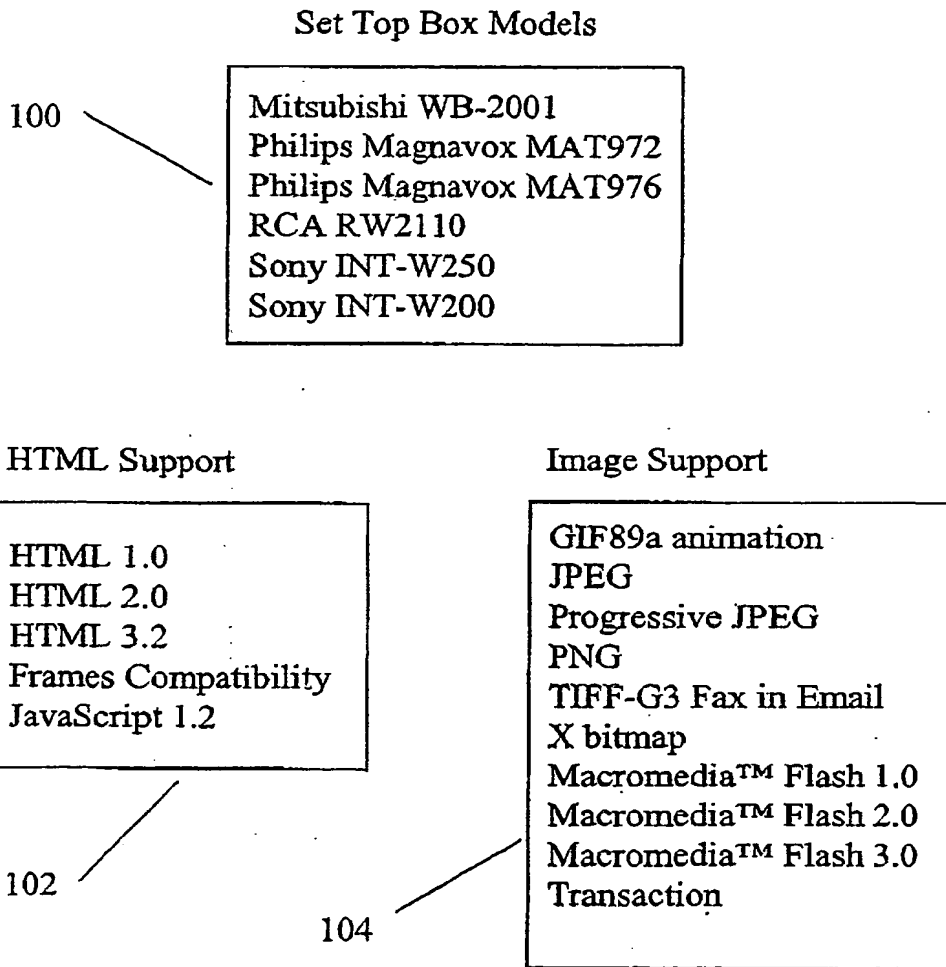

Figure 2

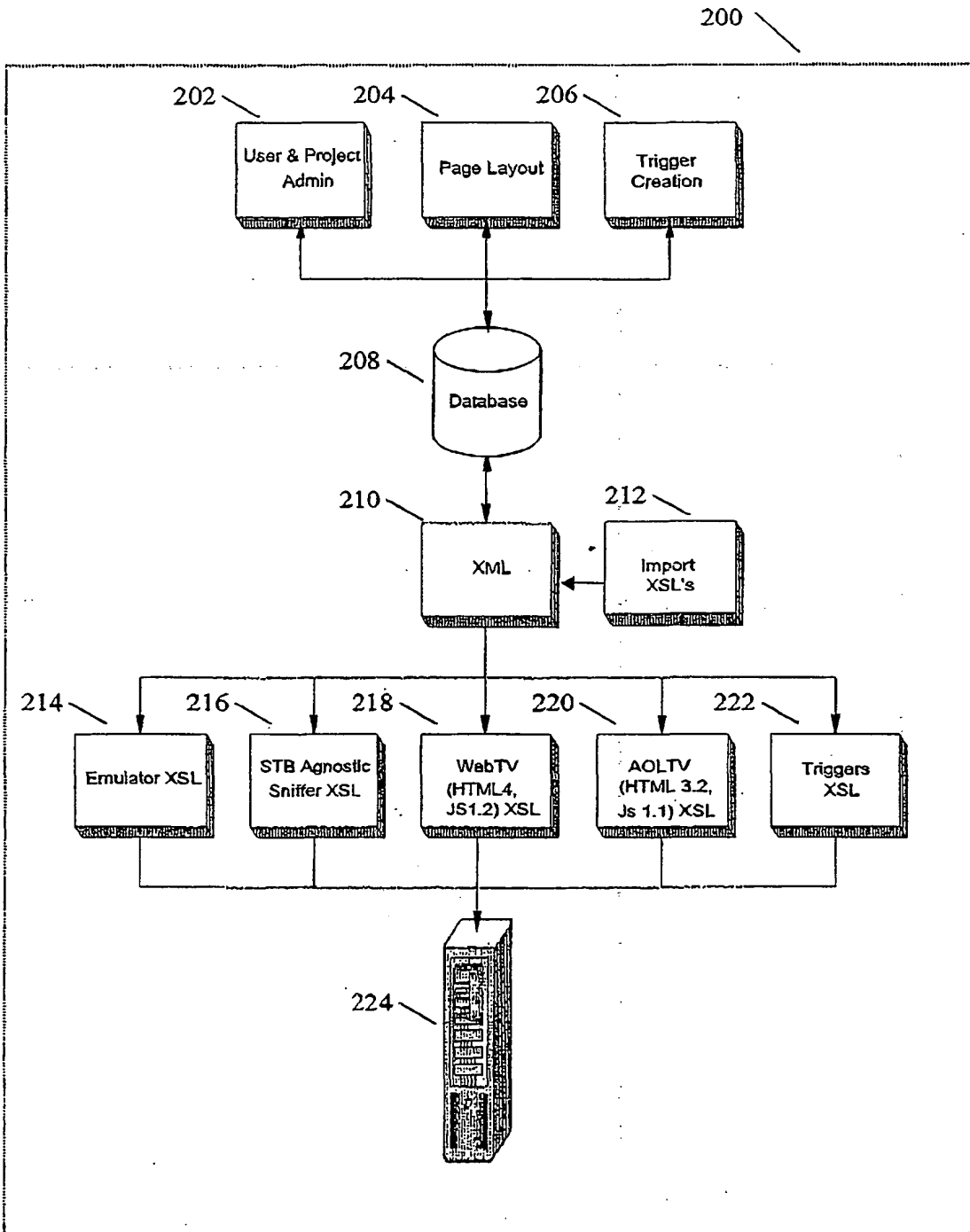

Figure 3

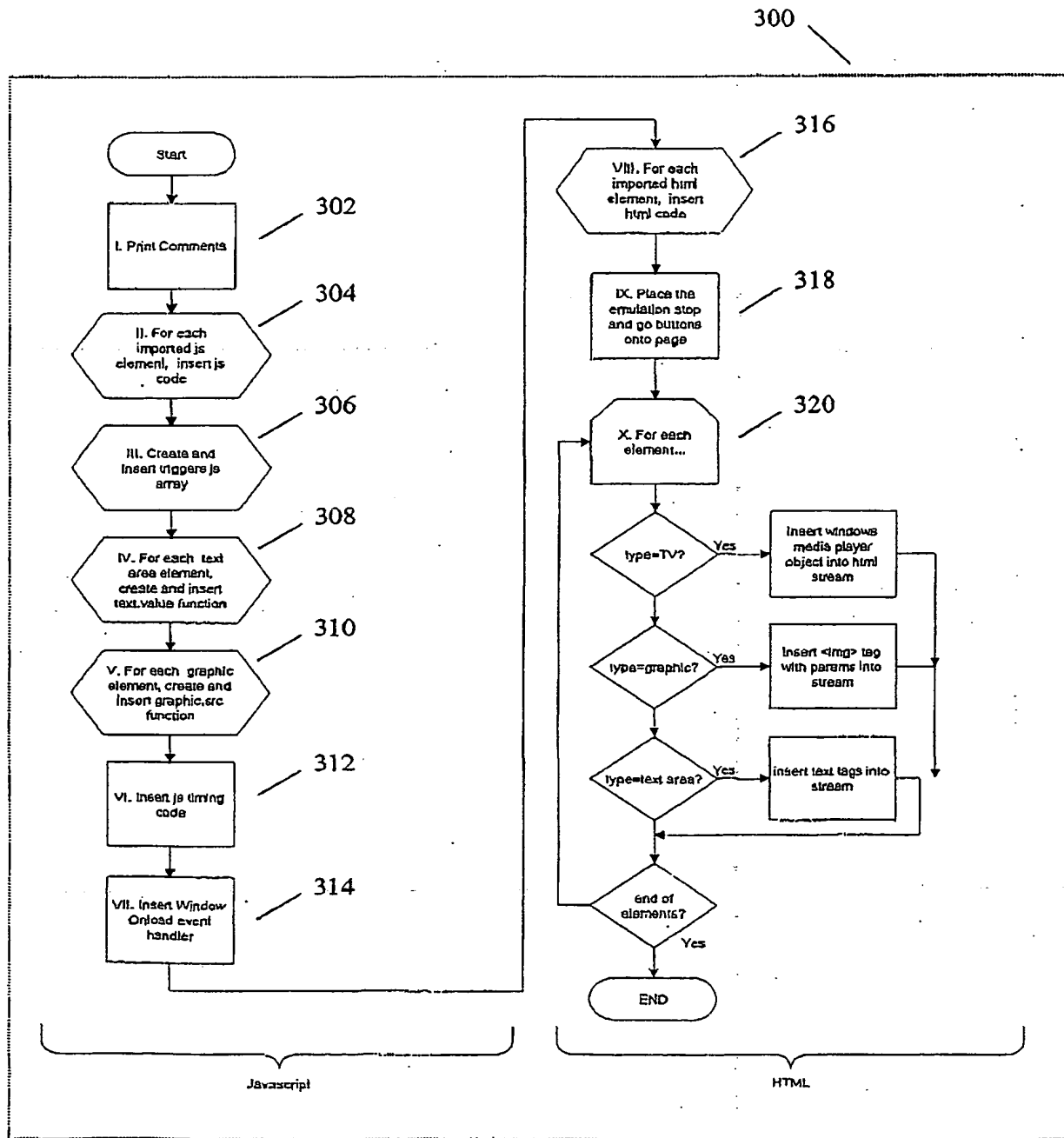

Figure 4

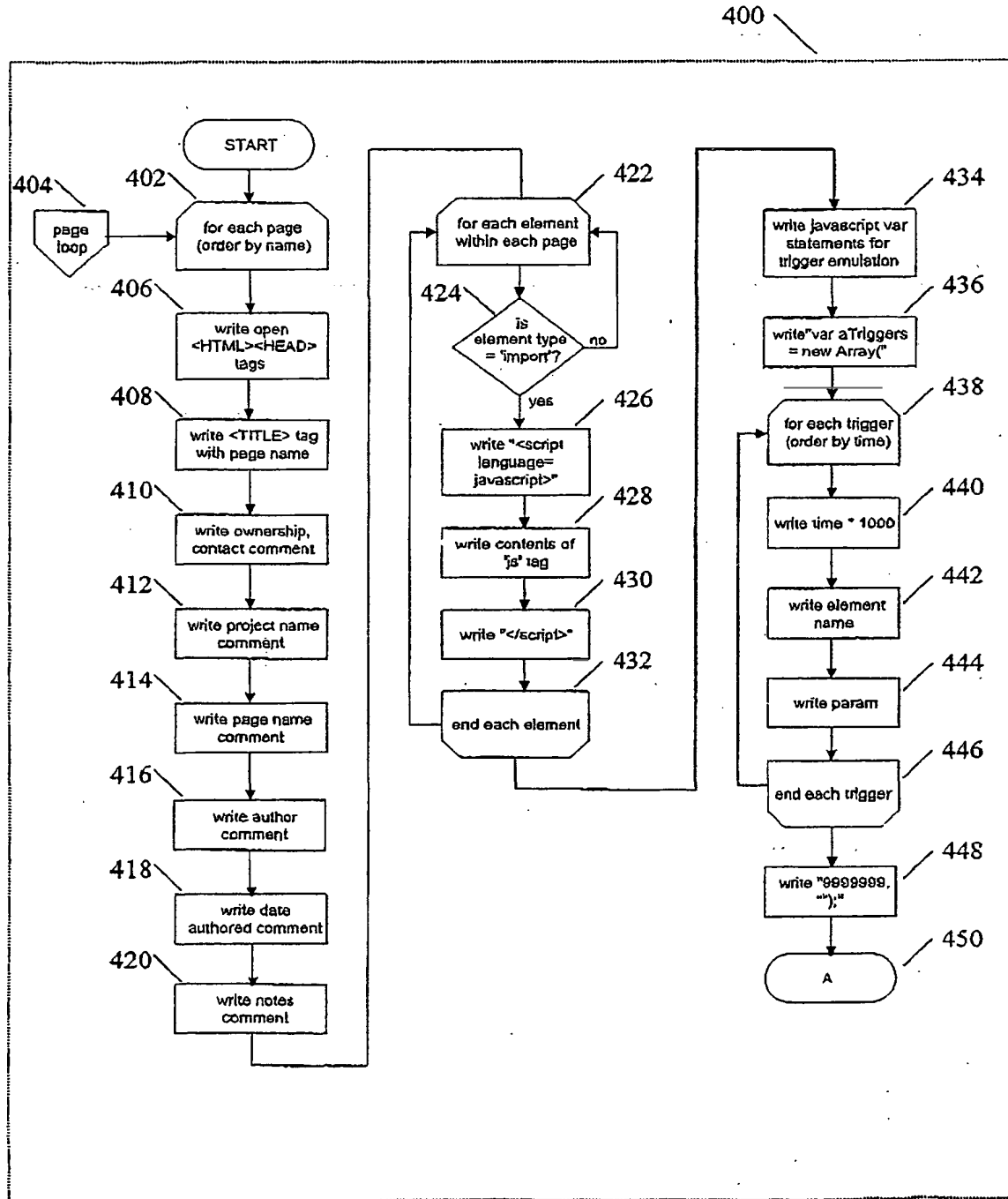

Figure 5

500

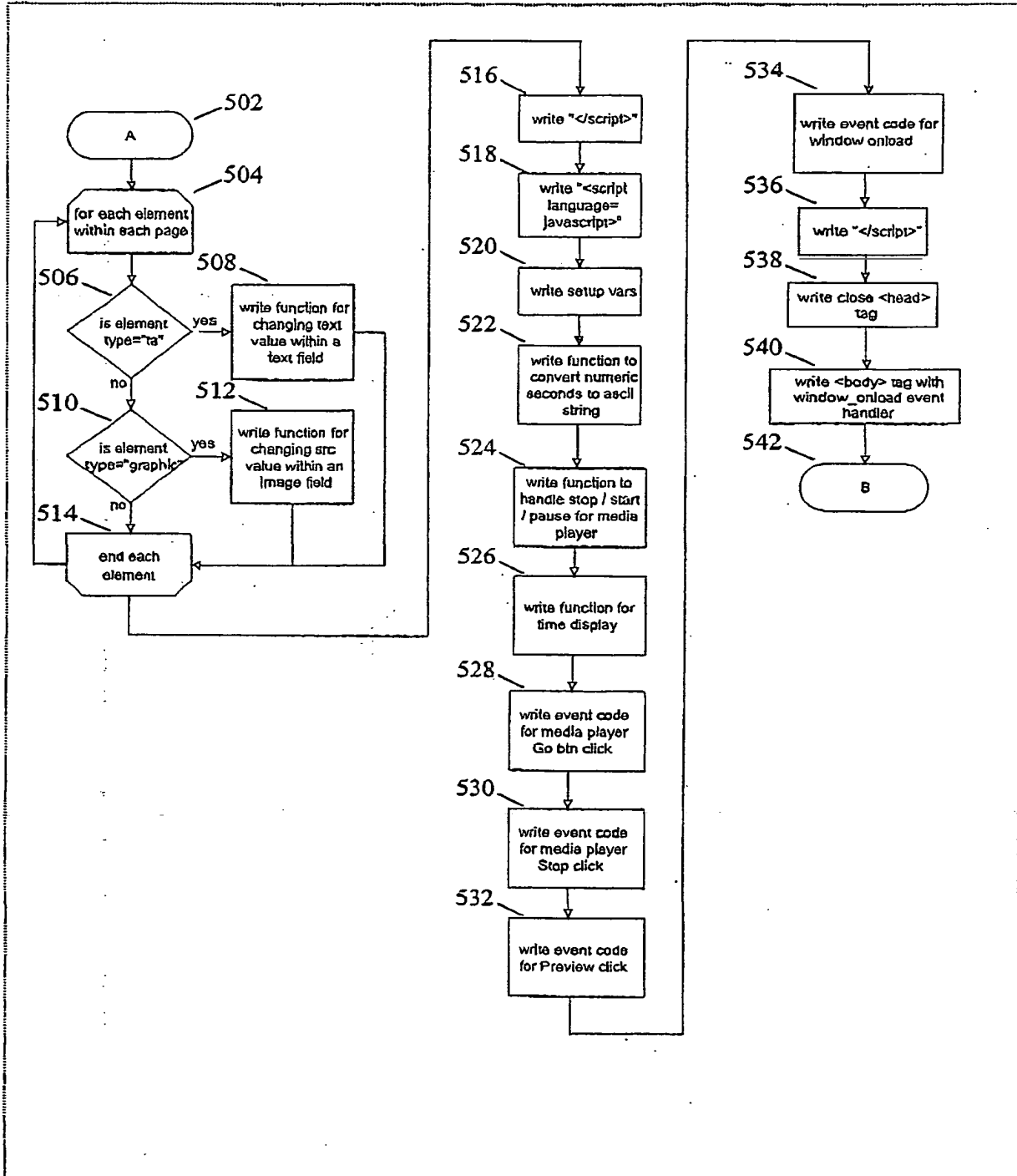

Figure 6

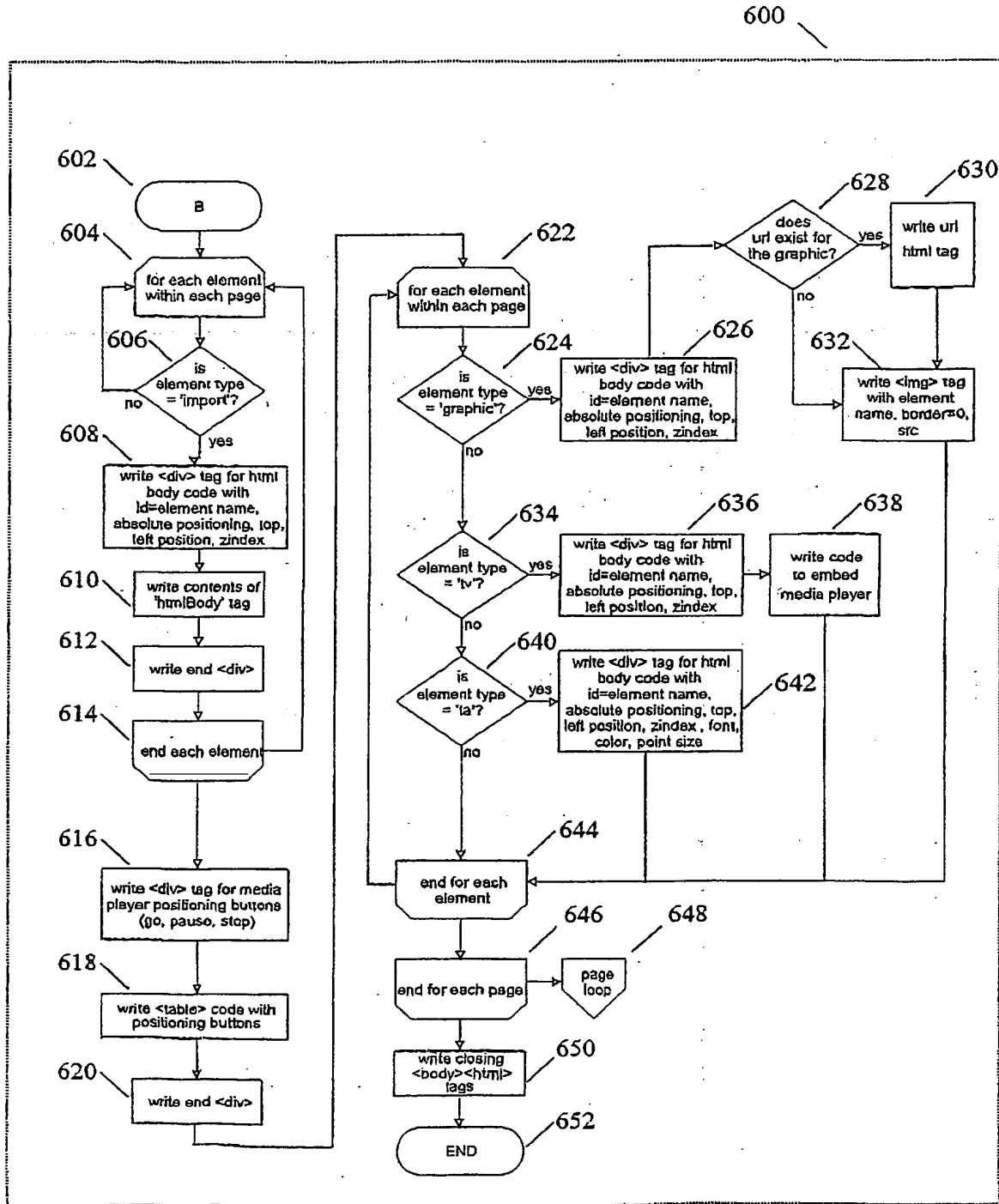
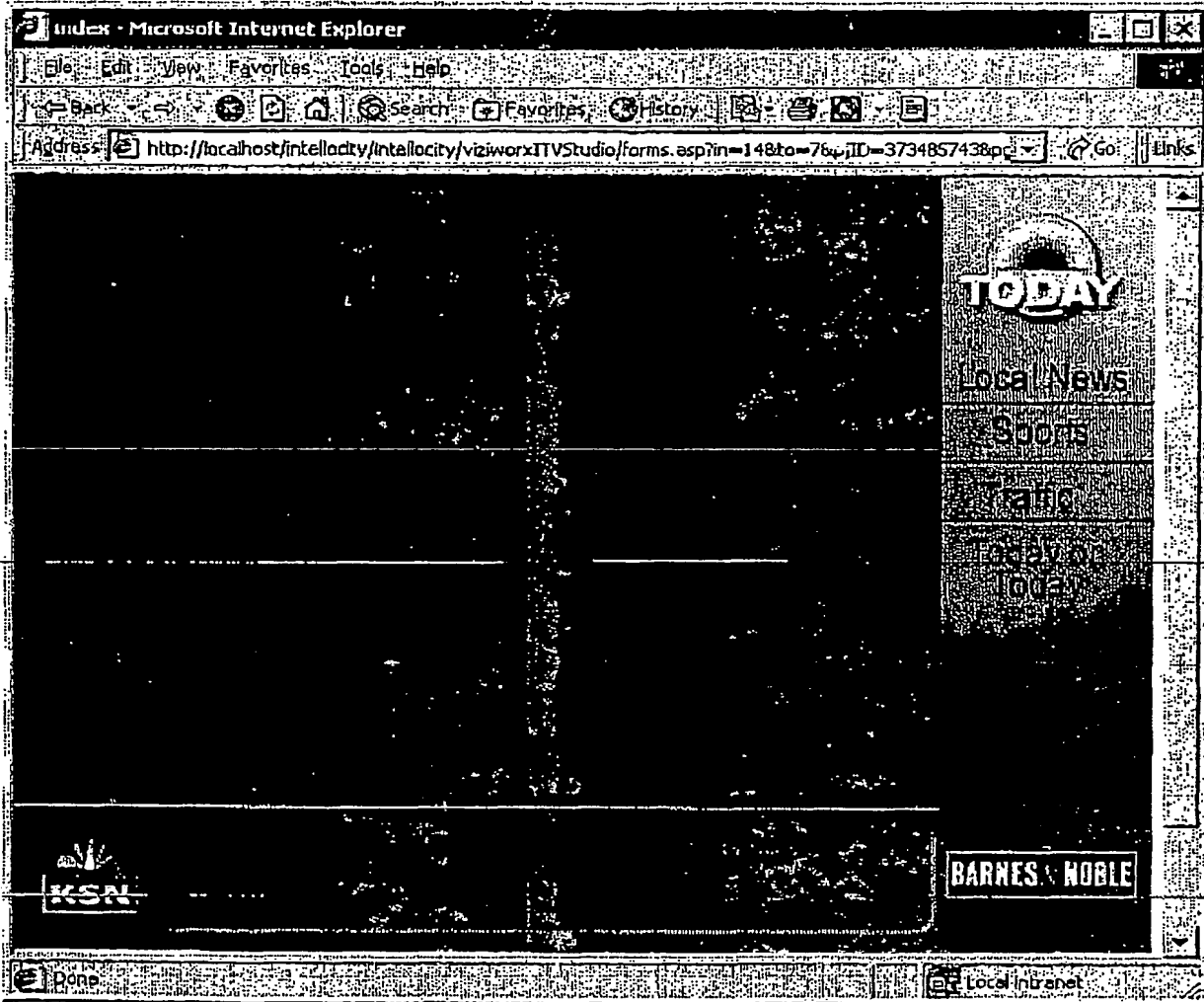

Figure 7



Best Available Copy

(19) World Intellectual Property Organization
International Bureau



(43) International Publication Date
28 February 2002 (28.02.2002)

PCT

(10) International Publication Number
WO 02/17639 A3

- (51) International Patent Classification⁷: H04N 7/16
- (72) Inventor; and
- (21) International Application Number: PCT/US01/26369
- (75) Inventor/Applicant (for US only): MARKEL, Steven, O. [US/US]; 3031 E. Wycliff Way, Highlands Ranch, CO 80126 (US).
- (22) International Filing Date: 21 August 2001 (21.08.2001)
- (74) Agents: GALLENSON, Mavis, S. et al.; 5670 Wilshire Blvd. Suite 2100, Los Angeles, CA 90036 (US).
- (25) Filing Language: English
- (81) Designated States (national): AE, AG, AL, AM, AT, AU, AZ, BA, BB, BG, BR, BY, BZ, CA, CH, CN, CO, CR, CU, CZ, DE, DK, DM, DZ, EC, EE, ES, FI, GB, GD, GE, GH, GM, HR, HU, ID, IL, IN, IS, JP, KE, KG, KP, KR, KZ, LC, LK, LR, LS, LT, LU, LV, MA, MD, MG, MK, MN, MW, MX, MZ, NO, NZ, PH, PL, PT, RO, RU, SD, SE, SG, SI, SK, SL, TJ, TM, TR, TT, TZ, UA, UG, US, UZ, VN, YU, ZA, ZW.
- (26) Publication Language: English
- (30) Priority Data:
 - 60/227,063 21 August 2000 (21.08.2000) US
 - 09/933,927 21 August 2001 (21.08.2001) US
- (71) Applicant (for all designated States except US): INTEL-LOCITY USA, INC. [US/US]; 1400 Market Street, Denver, CO 80202 (US).
- (84) Designated States (regional): ARIPO patent (GH, GM, KE, LS, MW, MZ, SD, SL, SZ, TZ, UG, ZW), Eurasian

[Continued on next page]

(54) Title: SYSTEM AND METHOD FOR TELEVISION ENHANCEMENT

Set Top Box Models

100

Mitsubishi WB-2001
 Philips Magnavox MAT972
 Philips Magnavox MAT976
 RCA RW2110
 Sony INT-W250
 Sony INT-W200

HTML Support

HTML 1.0
 HTML 2.0
 HTML 3.2
 Frames Compatibility
 JavaScript 1.2

102

Image Support

GIF89a animation
 JPEG
 Progressive JPEG
 PNG
 TIFF-G3 Fax in Email
 X bitmap
 Macromedia™ Flash 1.0
 Macromedia™ Flash 2.0
 Macromedia™ Flash 3.0
 Transaction

104

(57) Abstract: A text based script file describing enhancements is parsed to produce platform dependent enhancement files that may be employed to produce enhancements on a set topbox, enhanced television, or computer display. A script file may be of XML format and a parser may be an XSL translator. A parser may import HTML and Javascript from other applications. A parser may support a media player for emulation to view video enhancements. Trigger data for rendering enhancements may be formatted into a javascript array. Trigger events may be employed to replace graphic pointers or text values. Multiple parsers, each supporting a specific platform, allow a single script file to be employed across multiple platforms. New platforms or versions of platforms are supported through new or updated parsers.



WO 02/17639 A3



patent (AM, AZ, BY, KG, KZ, MD, RU, TJ, TM), European patent (AT, BE, CH, CY, DE, DK, ES, FI, FR, GB, GR, IE, IT, LU, MC, NL, PT, SE, TR), OAPI patent (BF, BJ, CF, CG, CI, CM, GA, GN, GQ, GW, ML, MR, NE, SN, TD, TG).

(88) Date of publication of the international search report:
30 May 2002

For two-letter codes and other abbreviations, refer to the "Guidance Notes on Codes and Abbreviations" appearing at the beginning of each regular issue of the PCT Gazette.

Published:

- *with international search report*
- *before the expiration of the time limit for amending the claims and to be republished in the event of receipt of amendments*

INTERNATIONAL SEARCH REPORT

International Application No

PCT/US 01/26369

A. CLASSIFICATION OF SUBJECT MATTER
IPC 7 H04N7/16

According to International Patent Classification (IPC) or to both national classification and IPC

B. FIELDS SEARCHED

Minimum documentation searched (classification system followed by classification symbols)
IPC 7 H04N

Documentation searched other than minimum documentation to the extent that such documents are included in the fields searched

Electronic data base consulted during the international search (name of data base and, where practical, search terms used)

EPO-Internal, WPI Data, PAJ, INSPEC

C. DOCUMENTS CONSIDERED TO BE RELEVANT

Category *	Citation of document, with indication, where appropriate, of the relevant passages	Relevant to claim No.
X	LI Q ; OZSOYOGLU Z M ; WAGNER R ; KAMBAYASHI Y ; ZHANG Y : " XML based text TV" PROCEEDINGS OF WISE 2000, 19 - 21 June 2000, pages 109-113, XP002192977 Hong Kong, China	1-7,9, 11-15, 17,18, 20,22,24
Y	page 110, left-hand column, paragraph 3 page 111, left-hand column, paragraph 1 -page 113, left-hand column, paragraph 6 --- -/--	8,16,19, 21,23

Further documents are listed in the continuation of box C.

Patent family members are listed in annex.

* Special categories of cited documents :

- *A* document defining the general state of the art which is not considered to be of particular relevance
- *E* earlier document but published on or after the international filing date
- *L* document which may throw doubts on priority claim(s) or which is cited to establish the publication date of another citation or other special reason (as specified)
- *O* document referring to an oral disclosure, use, exhibition or other means
- *P* document published prior to the international filing date but later than the priority date claimed

- *T* later document published after the international filing date or priority date and not in conflict with the application but cited to understand the principle or theory underlying the invention
- *X* document of particular relevance; the claimed invention cannot be considered novel or cannot be considered to involve an inventive step when the document is taken alone
- *Y* document of particular relevance; the claimed invention cannot be considered to involve an inventive step when the document is combined with one or more other such documents, such combination being obvious to a person skilled in the art.
- *&* document member of the same patent family

Date of the actual completion of the international search

13 March 2002

Date of mailing of the international search report

26/03/2002

Name and mailing address of the ISA

European Patent Office, P.B. 5818 Patentlaan 2
NL - 2280 HV Rijswijk
Tel. (+31-70) 340-2040, Tx. 31 651 epo nl,
Fax: (+31-70) 340-3016

Authorized officer

Sindic, G

NFLE 1002 - Page 171

INTERNATIONAL SEARCH REPORT

International Application No

PCT/US 01/26369

C.(Continuation) DOCUMENTS CONSIDERED TO BE RELEVANT

Category *	Citation of document, with indication, where appropriate, of the relevant passages	Relevant to claim No.
Y	<p>FERNANDEZ PANADERO M C ET AL: "Mass-customizing electronic journals" 'ONLINE!, 10 May 1999 (1999-05-10), pages 225-235, XP002177409</p>	16,19,23
A	<p>page 227, paragraph 3 page 229, paragraph 3 - paragraph 4 page 233, paragraph 3 - paragraph 4</p>	2
Y	<p>US 5 951 639 A (MACINNIS ALEXANDER G) 14 September 1999 (1999-09-14) column 2, line 26 - line 42</p>	8
Y	<p>JOSE ALVEAR: "REALNETWORKS' REALAUDIO AND REALVIDEO" WEB DEVELOPPER.COM GUIDE TO STREAMING MULTIMEDIA, NEW YORK: JOHN WILEY & SONS, US, 1998, pages 183-202, XP002150113 ISBN: 0-471-24822-3 page 193, paragraph 4 - paragraph 5</p>	21

INTERNATIONAL SEARCH REPORT

Information on patent family members

International Application No

PCT/US 01/26369

Patent document cited in search report	Publication date	Patent family member(s)	Publication date
US 5951639	A	AU 1693597 A	02-09-1997
		EP 0880857 A1	02-12-1998
		WO 9730549 A1	21-08-1997

...s Page Blank (uspto)

(19) World Intellectual Property Organization
International Bureau



(43) International Publication Date
28 February 2002 (28.02.2002)

PCT

(10) International Publication Number
WO 02/017639 A3

- (51) International Patent Classification⁷: **H04N 7/16**
- (21) International Application Number: PCT/US01/26369
- (22) International Filing Date: 21 August 2001 (21.08.2001)
- (25) Filing Language: English
- (26) Publication Language: English
- (30) Priority Data:

60/227,063	21 August 2000 (21.08.2000)	US
09/933,927	21 August 2001 (21.08.2001)	US
- (71) Applicant (for all designated States except US): **INTELLOCITY USA, INC.** [US/US]; 1400 Market Street, Denver, CO 80202 (US).
- (72) Inventor; and
- (75) Inventor/Applicant (for US only): **MARKEL, Steven, O.** [US/US]; 3031 E. Wyecliff Way, Highlands Ranch, CO 80126 (US).
- (74) Agents: **GALLENSON, Mavis, S. et al.**; 5670 Wilshire Blvd. Suite 2100, Los Angeles, CA 90036 (US).
- (81) Designated States (national): AE, AG, AL, AM, AT, AU, AZ, BA, BB, BG, BR, BY, BZ, CA, CH, CN, CO, CR, CU, CZ, DE, DK, DM, DZ, EC, EE, ES, FI, GB, GD, GE, GH, GM, HR, HU, ID, IL, IN, IS, JP, KE, KG, KP, KR, KZ, LC, LK, LR, LS, LT, LU, LV, MA, MD, MG, MK, MN, MW, MX, MZ, NO, NZ, PH, PL, PT, RO, RU, SD, SE, SG, SI, SK, SL, TJ, TM, TR, TT, TZ, UA, UG, US, UZ, VN, YU, ZA, ZW.
- (84) Designated States (regional): ARIPO patent (GH, GM, KE, LS, MW, MZ, SD, SL, SZ, TZ, UG, ZW), Eurasian

[Continued on next page]

(54) Title: SYSTEM AND METHOD FOR TELEVISION ENHANCEMENT

Set Top Box Models

100

Mitsubishi WB-2001
Philips Magnavox MAT972
Philips Magnavox MAT976
RCA RW2110
Sony INT-W250
Sony INT-W200

HTML Support

HTML 1.0
HTML 2.0
HTML 3.2
Frames Compatibility
JavaScript 1.2

102

Image Support

GIF89a animation
JPEG
Progressive JPEG
PNG
TIFF-G3 Fax in Email
X bitmap
Macromedia™ Flash 1.0
Macromedia™ Flash 2.0
Macromedia™ Flash 3.0
Transaction

104

(57) Abstract: A text based script file describing enhancements is parsed to produce platform dependent enhancement files that may be employed to produce enhancements on a set topbox, enhanced television, or computer display. A script file may be of XML format and a parser may be an XSL translator. A parser may import HTML and Javascript from other applications. A parser may support a media player for emulation to view video and enhancements. Trigger data for rendering enhancements may be formatted into a javascript array. Trigger events may be employed to replace graphic pointers or text values. Multiple parsers, each supporting a specific platform, allow a single script file to be employed across multiple platforms. New platforms or versions of platforms are supported through new or updated parsers.

WO 02/017639 A3



patent (AM, AZ, BY, KG, KZ, MD, RU, TJ, TM), European patent (AT, BE, CH, CY, DE, DK, ES, FI, FR, GB, GR, IE, IT, LU, MC, NL, PT, SE, TR), OAPI patent (BF, BJ, CF, CG, CI, CM, GA, GN, GQ, GW, ML, MR, NE, SN, TD, TG).

(88) Date of publication of the international search report:
30 May 2002

Date of publication of the amended claims: 13 March 2003

Published:

- with international search report
- with amended claims

For two-letter codes and other abbreviations, refer to the "Guidance Notes on Codes and Abbreviations" appearing at the beginning of each regular issue of the PCT Gazette.

AMENDED CLAIMS

[received by the International Bureau on 12 April 2002 (12.04.2002);
new claims 25-27 added, remaining claims unchanged (2 pages)]

20. A system for developing television enhancements comprising:

a computer;

a database;

a web browser; and

a parser operable to parse a platform independent television enhancement file contained in said database and to produce an output file that may be viewed employing said browser.

21. The system of claim 20 further comprising:

a parser component operable to enable display of a media player if said television enhancement file contains an element representative of a television image.

22. The system of claim 20 wherein said parser is operable to create an output file for a specific platform.

23. The system of claim 20 wherein said parser is operable to translate a color value associated with an element contained in said television enhancement file.

24. A parser for producing a platform specific television enhancement file comprising:

a function to access a platform independent television enhancement file comprising project information, a description of an element, the position of said element, and a time at which said element may be rendered.

a function to create an HTML header containing said project information;

a function to place said position of said element between division tags in an HTML output file if said element is either a text element or a graphic element;

a function to insert javascript code associated with said element if said element is an imported element;

a function to embed a media player in an HTML file if said element is a representative of a television;

a function to update an address at which said element may be accessed; and

a function to create and store triggers in a javascript array.

25. The parser of claim 24 wherein said parser is XSL compliant.

26. The parser of claim 24 further comprising:

a function that imports HTML code.

27. The parser of claim 24 further comprising:

a function to translate a color value.

A3

(12) UK Patent Application (19) GB (11) 2 332 803 (13) A

(43) Date of A Publication 30.06.1999

(21) Application No 9827824.5
(22) Date of Filing 17.12.1998
(30) Priority Data
(31) 97039408 (32) 20.12.1997 (33) KR

(51) INT CL⁶
H04N 5/775
(52) UK CL (Edition Q)
H4F FAAN FD12X FD3P FD3R FD3T FD30K
(56) Documents Cited
EP 0852361 A2
(58) Field of Search
UK CL (Edition Q) H4F FAAN FAAX FEHM FEHX FKX
INT CL⁶ H04N 5/00 5/76 5/765 5/775
Online:WPI, EPODOC

(71) Applicant(s)
Daewoo Electronics Co., Ltd
(Incorporated in the Republic of Korea)
541 5-Ga, Namdaemoon-Ro, Jung-Ku, Seoul,
Republic of Korea
(72) Inventor(s)
Seok-Jin Won
(74) Agent and/or Address for Service
Page White & Farrer
54 Doughty Street, LONDON, WC1N 2LS,
United Kingdom

(54) Abstract Title
DAVIC system supporting a JAVA-based client device

(57) A DAVIC system comprises two types of client devices, one type 220 operating based on Java and the other type 210 operating based on MHEG-5, and a server 200 capable of serving both types of client devices, for providing a client device with an application upon request from the client device.

The server 200 identifies the type of client device by using an extension included in the request generated from the client device.

FIG. 2

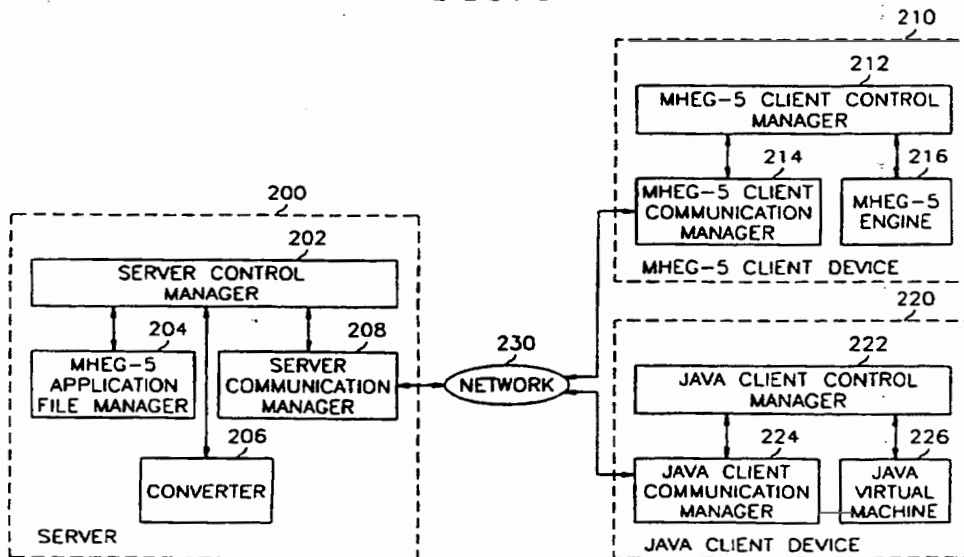

GB 2 332 803 A

A

FIG. 1
(PRIOR ART)

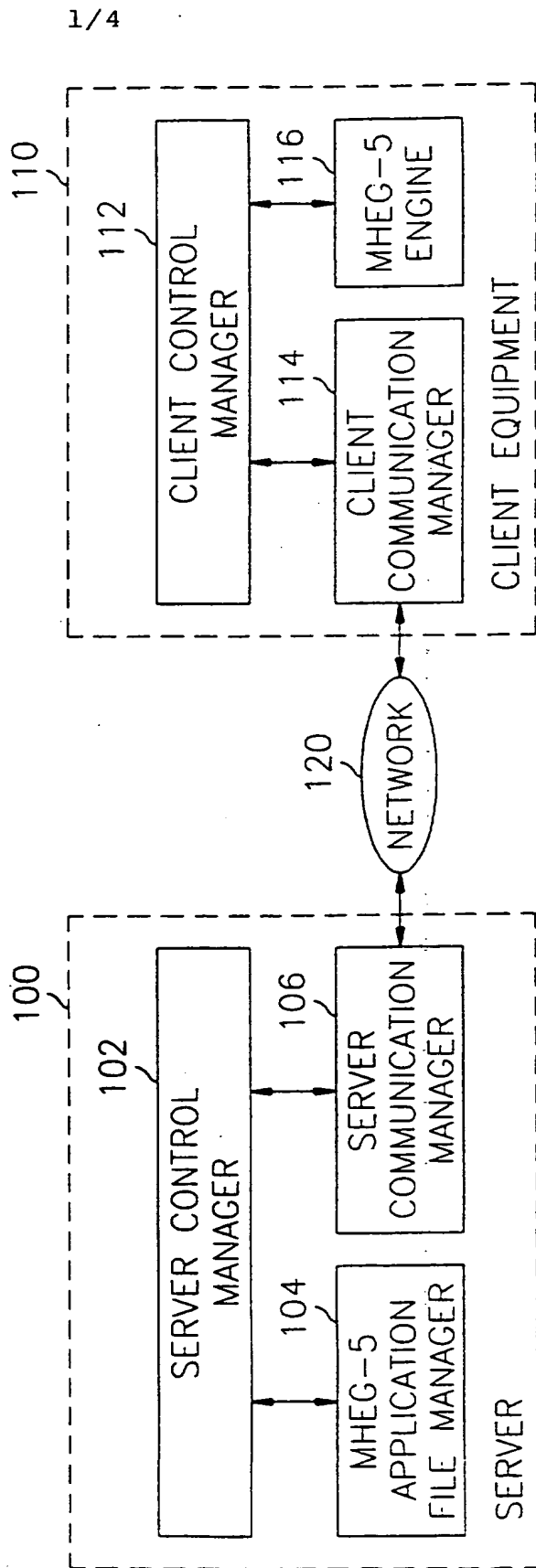

FIG.2

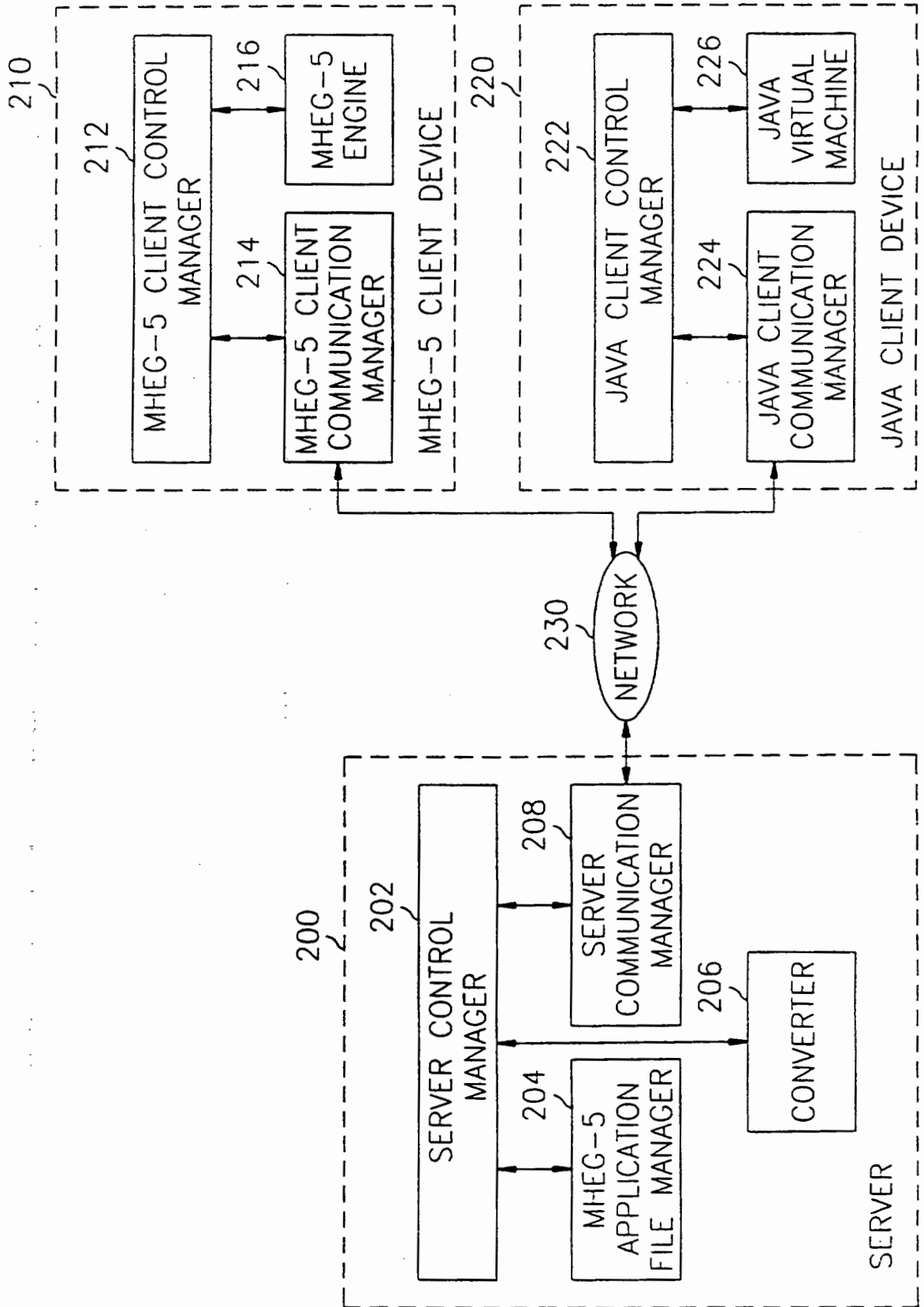

FIG. 3

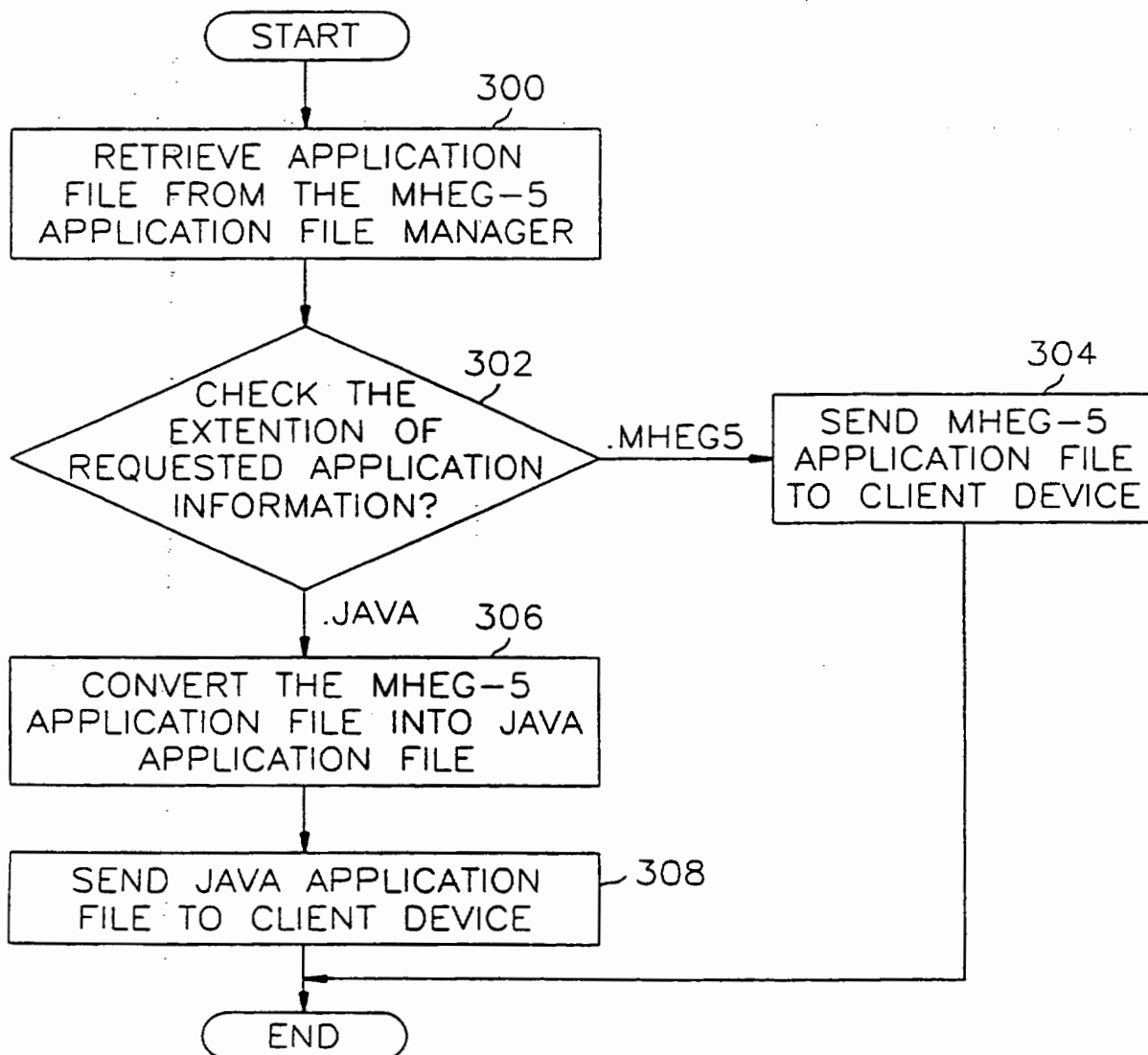

FIG. 4

FORMATS OF APPLICATION FILES STORED IN SERVER	FORMATS OF APPLICATION FILES REQUESTED FROM JAVA CLIENT	FORMATS OF APPLICATION FILES REQUESTED FROM MHEG-5 CLIENT
APPL_1.MHEG5 APPL_2.MHEG5 APPL_3.MHEG5 : : : :	APPL_1.JAVA APPL_2.JAVA APPL_3.JAVA : : : :	APPL_1.MHEG5 APPL_2.MHEG5 APPL_3.MHEG5 : : : :

DAVIC SYSTEM SUPPORTING A JAVA-BASED CLIENT DEVICE

The present invention relates to a DAVIC system; and,
5 more particularly, to a DAVIC system capable of supporting a
Java-based client device.

DAVIC (Digital Audio Visual Council) sets industry
10 standards for interactive digital audio-visual information and
multimedia communications. A DAVIC system may be defined as
an integrated system of hardware and software in conformity
with the DAVIC specifications.

As an example of the DAVIC system, a VOD (Video On
15 Demand) system is a combination of devices such as a server,
client equipment and a network for providing a client with an
audio-video program, e.g., a movie, on demand. To meet the
demand, the VOD system provides end-user inter-activities
(such as select video, play, pause and stop) and employs
20 familiar graphical user interfaces.

The DAVIC system is basically comprised of a server, a
plurality of client equipment connected via a network
therebetween. The server stores various applications to
provide corresponding applications to each client equipment
25 on demand. The network delivers bi-directional control
signals as well as data for the applications, wherein the

applications refer to collections of software for use in displaying service formats to facilitate the use of a DAVIC service, for example, a menu, a program list, a movie program, etc.

5 The server may be made up of computers such as workstations, backed up by multiple disks or large memories to store the applications, e.g., digital moving pictures. Conventionally, the data on the digital moving pictures is compressed prior to being stored in the disks or the memories
10 in conformity with the MPEG-1 and MPEG-2 (Moving Picture Expert Group-1 and -2) standards.

 The client equipment includes a display device and a console, one of the so-called set-top boxes, for use in demanding a specific application and controlling progress of
15 the video. The console is equipped with such keys as numerics 0-9, play, pause, fast forward/reverse and certain service-specific keys.

 The network, for delivering the applications and control signals between the server and the client equipment, may be
20 configured with any one of a CATV (Community Antenna Television) network, a conventional telephone network, an ATM (Asynchronous Transfer Mode) network and the like.

 With respect to the user interface, the DAVIC system adopts a MHEG-5 (Multimedia and Hypermedia information coding
25 Expert Group-5) specification. The MHEG-5 specification is a standard provided by the ISO (International Standardization

Organization), defined over a final-form representation for exchanging the applications, which allows a versatility thereto so that it may run on many different kinds of client/server environments.

5 A conventional DAVIC system adopting the MHEG-5 specification is described in Fig. 1. A server 100 includes a server control manager 102, a server communication manager 106 and a MHEG-5 application file manager 104. In the client equipment 110, a client control manager 112, a client communication manager 114 and an MHEG-5 engine 116 are
10 installed.

 If an application is requested from the client equipment 110, the MHEG-5 application file manager 104 in the server 100 conducts a search of the requested application in response to
15 the request from the client equipment 110. After the search, the client control manager 112 downloads the requested application to the client equipment 110 via the client communication manager 114. The client equipment 110 processes the downloaded application by using the MHEG-5 engine 116 and
20 finally displays the requested application.

 In the conventional DAVIC system, the MHEG-5 engine 116 employed in the client equipment 110 has been implemented by using software. Therefore, a large volume of memory resources is required to install the MHEG-5 engine 116 implemented with
25 software. The cost of the memory resources exacts more manufacturing cost of the client equipment 110. Therefore,

there has existed a need to reduce the volume of the memory resources taken up by the MHEG-5 engine 116.

Further, the MHEG-5 specification has an inherent limitation in providing a variety of features, especially with respect to the expression of the applications. In this connection, a Java software is more versatile than the MHEG-5 specification for the expression of applications.

In addition, if the DAVIC system intends to provide services for a Java-based client equipment as well as a MHEG-5-based client equipment, a method for an efficient identification of the type of the client equipment will be required.

It is, therefore, a primary object of the present invention to provide a DAVIC system capable of accommodating a Java-based client equipment which requires less memory therein than the conventional counterpart.

It is another object of the present invention to provide a method for simply identifying the type of the client equipment.

In accordance with one aspect of the present invention, there is provided a DAVIC system comprising: a plurality of client devices, the client devices including two types thereof, one type operating based on a Java and the other type operating based on a MHEG-5 specification; and a server,

capable of serving both types of the client devices, for providing an application upon request from the client device.

In accordance with another aspect of the present invention, there is provided a DAVIC system wherein the server identifies the type of the client device by using an extension included in the request information generated from the client device.

10 The above and other objects and features of the present invention will become apparent from the following description of preferred embodiments given with reference to the accompanying drawings, in which:

Fig. 1 describes a conventional DAVIC system operating based on a MHEG-5 specification;

Fig. 2 presents a DAVIC system in accordance with the present invention;

Fig. 3 illustrates a process performed in a server control manager; and

20 Fig. 4 depicts exemplary formats of application files stored in a server.

A DAVIC system in accordance with the present invention is shown in Fig. 2.

The inventive DAVIC system is comprised of a server 200,

two types of client devices 210, 220 and a network 230.

The server 200 includes a server control manager 202 for controlling the entire functions thereof, a server communication manager 208 for interfacing the server 200 with
5 the network 230, a MHEG-5 application file manager 204 for storing applications in the form of a MHEG-5 file and a converter 206 for converting MHEG-5 applications into Java applications.

A MHEG-5 client device 210 is essentially same as the one
10 described in the prior art.

The Java client device 220 includes a Java client control manager 222 for controlling the entire functions thereof, a Java client communication manager 224 for interfacing the Java client device 220 with the network 230 and a Java virtual
15 machine 226 for displaying the applications received from the server.

Herein, Java or a Java software, developed by Sun Microsystems, is a collection of codes and tools that can be used to create applications software, such as a spreadsheet,
20 a game or a World Wide Web site. It has powerful advantages over conventional languages or software. For example, a Java technology eliminates many of the problems associated with installing and running applications, and, therefore, eliminates a need to manage memories associated therewith.
25 Java is also a platform-independent software, which frees a user to pick up any hardware and operating system best suited

to one's needs.

The operation of the inventive DAVIC system will now be described. For the purpose of illustration, it is assumed that the server 200 serves the Java client device 220 except
5 otherwise specified.

A client inputs a request information requesting a video on demand service at the client device 220. The Java client control manager 222 informs the Java client communication manager 224 of the request information. The Java client
10 communication manager 224 sends the request information to the server 200 via the network 230.

The request information is received at the server communication manager 208 and delivered to the server control manager 202. The server control manager 202 executes an
15 identification process upon the client's request based on the delivered request information as described in Fig. 3.

Fig. 3 illustrates the identification process performed in the server control manager 202.

At step 300, the server control manager 202 retrieves an
20 application file corresponding to the request information from the MHEG-5 application file manager 204 upon receiving the request information from the server communication manager 208. At step 302, the server control manager 202 accesses an extension included in the request information in order to
25 identify whether the client device which issued the request information is based on the MHEG-5 specification or the Java.

In Fig. 4, there are illustrated formats of the application files stored in the MHEG-5 application file manager 204 of the server 200, formats of the application files requested from the Java client device 220 and from the MHEG-5 client device 210, respectively. To each of the application files requested from the Java client device 220 and the MHEG-5 client device 210, there is attached an extension of "java" and "mheg5", respectively, as shown in Fig. 4. With these extensions, the server control manager 202 can identify the nature of the client devices, i.e., whether it is the Java-based or the MHEG-5-based. The extension will be "mheg5" if the client device is operating based on the MHEG-5 specification, while, the extension will be "java" if the client device is operating based on the Java.

Using the extensions in identifying the nature of the client device eliminates any modification to the existing protocol between the server and the client device in the DAVIC system. In other words, if the identification is not performed by using the extensions, there may need a protocol or a procedure in addition to the existing protocol of DAVIC system so as to identify the nature of client devices.

In the above, the order of the step 300 and step 302 may be reversed or these steps may be executed in parallel since they are performed independently.

If the extension in the request information turns out to be the MHEG-5 at step 302, the server control manager 202

orders the server communication manager 208 to transfer the
retrieved application file to the client device at step 304.
If otherwise, i.e., the extension in the request information
turns out to be the Java, the converter 206 converts the
5 retrieved application file which is based on the MHEG-5 into
the one based on the Java at step 306. The server control
manager 202 then orders the server communication manager 208
to transfer the converted application file to the client
device at step 308. By using this identification process, the
10 client device 220, operating based on the Java, can be
provided with an application file in conformity with the type
thereof.

The converted application file is downloaded to the
client communication manager 224 via the network 230. The
15 Java virtual machine 226 manipulates the downloaded
application file, and, then, displays the manipulated result.

As described above, the inventive DAVIC system is capable
of providing a video on demand service not only to the MHEG-5-
based client device 210 but also to the Java-based client
20 device 220 just by employing the converter 206 therein without
having to modify the existing MHEG-5 application file manager
204.

Accommodating the Java-based client device 220 in the
DAVIC system has a number of advantages such as: first, a
25 manufacturer can produce an inexpensive client device since
the Java virtual machine involves less memory than MHEG-5

engine; second, the processing speed of the Java-based client device 220 can be improved since the Java virtual machine 226 can alternatively be implemented with only hardware, contrary to the MHEG-5 engine 216 which is not implemented with hardware; and, third, the server can provide a client with more variety of features of applications such as a 3-dimensional graphic display and an animation since the Java is more versatile than the MHEG-5 in displaying various features.

10 Further, if the conventional DAVIC system intends to accommodate the Java-based client device 220 in addition to the MHEG-5-based client device 210, existing DAVIC specifications should be modified for a new feature. In other words, a protocol or a procedure should be incorporated in the server 200 in order to identify the type of the client device to be served. Adopting the inventive method, however, i.e., identifying the type of the client device by using the extension of the application files requested from the client device, eliminates the need to modify or add the new feature.

15

20 Therefore, the inventive DAVIC system can serve the Java-based client device 220 as well as the MHEG-5 based client device 210 by simply adding only the converter 206 thereto.

While the present invention has been described with respect to the preferred embodiments, other modifications and variations may be made without departing from the scope of the present invention as set forth in the following claims.

25

Claims:

1. A DAVIC system comprising:

5 a plurality of client devices, the client devices including two types thereof, one type operating based on a Java and the other type operating based on a MHEG-5; and

a server, capable of serving both types of the client devices, for providing a client device with an application upon request from the client device.

10

2. The DAVIC system of claim 1, wherein the DAVIC system further comprises a communication network between the server and the client devices for transferring signals including the request and the application.

15

3. The DAVIC system of claim 2, wherein each of the MHEG-5-based client devices includes:

a MHEG-5 client control manager for controlling the entire functions of the MHEG-5-based client device;

20

a MHEG-5 client communication manager for interfacing the MHEG-5-based client device with the communication network; and

a MHEG-5 engine for displaying the application.

25

4. The DAVIC system of claim 3, wherein each of the Java-based client devices includes:

a Java client control manager for controlling the entire

functions of the Java-based client device;

a Java client communication manager for interfacing the Java-based client device with the communication network; and
a Java virtual machine for displaying the application.

5

5. The DAVIC system of claim 4, wherein the server includes:
a server control manager for controlling the entire functions thereof;

a server communication manager for interfacing the server
10 with the communication network;

a MHEG-5 application file manager for storing MHEG-5-based applications; and

a converter for converting the MHEG-5-based applications into Java-based applications.

15

6. The DAVIC system of claim 5, wherein the applications stored in the MHEG-5 application file manager are in the format of a file with an extension of ".mheg5".

20 7. The DAVIC system of claim 6, wherein the request from the MHEG-5-based client devices has the format of a file with an extension of ".mheg5".

8. The DAVIC system of claim 7, wherein the request from the
25 Java-based client devices has the format of a file with an extension of ".java".

9. The DAVIC system of claim 8, wherein the server performs an identification procedure in which the server control manager identifies the type of the client device by using the extension included in the request.

5

10. The DAVIC system of claim 9, wherein the server control manager controls the server communication manager to send the application corresponding to the request to the client device which has issued the request if the client device is determined to be of a MHEG-5 type.

10

11. The DAVIC system of claim 10, wherein the server control manager controls the converter therein to convert the application corresponding to the request into a converted Java-based application, and, then, controls the server communication manager to send the converted Java-based application to the client device which has issued the request if the client device is determined to be of a Java type.

15

12. The DAVIC system of claim 11, wherein the DAVIC system is a video on demand system.

20

13. The DAVIC system of claim 11, wherein the communication network is a CATV network.

25

14. The DAVIC system of claim 13, wherein the communication

network is a conventional telephone network.

15. The DAVIC system of claim 14, wherein the communication network is a ATM (Asynchronous Transfer Mode) network.

5

16. An apparatus constructed and arranged substantially as hereinbefore described with reference to or as shown in figures 2 to 4 of accompanying drawings.



Application No: GB 9827824.5
Claims searched: 1 to 16

Examiner: John Donaldson
Date of search: 26 April 1999

**Patents Act 1977
Search Report under Section 17**

Databases searched:

UK Patent Office collections, including GB, EP, WO & US patent specifications, in:

UK Cl (Ed.Q): H4F(FAAN, FAAX, FEHM, FEHX, FKX)

Int Cl (Ed.6): H04N 5/00, 5/76, 5/765, 5/775

Other: Online:WPI, EPODOC

Documents considered to be relevant:

Category	Identity of document and relevant passage	Relevant to claims
A, P	EP 0852361 A2 (TEXAS INSTRUMENTS), see abstract	

X	Document indicating lack of novelty or inventive step	A	Document indicating technological background and/or state of the art.
Y	Document indicating lack of inventive step if combined with one or more other documents of same category.	P	Document published on or after the declared priority date but before the filing date of this invention.
&	Member of the same patent family	E	Patent document published on or after, but with priority date earlier than, the filing date of this application.

A4

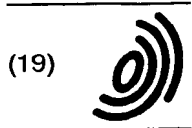

Europäisches Patentamt
European Patent Office
Office européen des brevets



(11) EP 0 837 599 A2

(12) EUROPEAN PATENT APPLICATION

(43) Date of publication: 22.04.1998 Bulletin 1998/17
(51) Int. Cl.⁶: H04N 5/00
(21) Application number: 97117900.7
(22) Date of filing: 16.10.1997

(84) Designated Contracting States:
AT BE CH DE DK ES FI FR GB GR IE IT LI LU MC
NL PT SE
Designated Extension States:
AL LT LV RO SI
(30) Priority: 21.10.1996 US 734681
(71) Applicant:
Nextlevel Systems, Inc.
Chicago, Illinois 60631 (US)

(72) Inventors:
• Eyer, Mark K.
San Diego, California 92131 (US)
• Field, Michael
San Diego, California 92130 (US)
(74) Representative:
Hoeger, Stellrecht & Partner
Uhlandstrasse 14 c
70182 Stuttgart (DE)

(54) Hypertext markup language protocol for television display and control

(57) Textual and graphical displays are provided on a television screen using a hypertext markup language (HTML). On-screen display devices allow a user to invoke hyperlinks to different pages of HTML-coded data in addition to function calls for controlling television and non-television appliance functions. A method provides HTML-coded display data which is processed to provide a signal suitable for reproduction on a television. The display data may provide information on a featured movie (325) or other presentation of an associated video programming service signal such as a network television broadcast (315). Function calls (232, 510, 530, 550) allow the control of various television functions and programming options, such as the pur-

chase of pay-per-view programming (330), or television display options such as aspect ratio (512, 514), channel, brightness (518), picture-in-picture, or split-screen. Non-television appliances which may be controlled with function calls include audio equipment which is associated with the programming service (e.g., surround sound (552), filtering (554, 556)) in addition to, for instance, a home heating and air conditioning system (536, 538) or other household appliances (532, 534). The invention allows a designer to adapt the vast HTML resources of the Internet for use in the television environment for entertainment, educational or informational purposes.

FIG.1

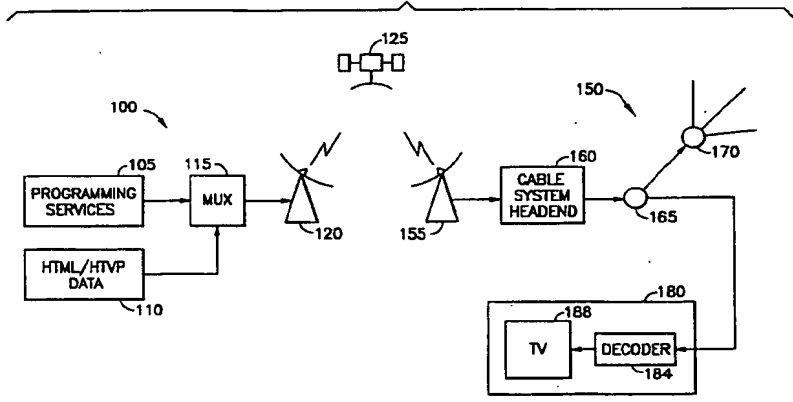

EP 0 837 599 A2

MA

Description

BACKGROUND OF THE INVENTION

5 The present invention relates to an apparatus and method for providing textual and graphical displays using hyper-
text markup language (HTML) in a television decoder. Additionally, HTML is adapted for use in controlling various tele-
vision functions.

10 Hypertext Markup Language (HTML) is a system for marking documents to indicate how the document should be
displayed, and how various documents should be linked together. HTML has been used extensively to provide docu-
ments on the computer communications network known as the Internet. The Internet includes a vast collection of inter-
connected documents which are stored in computers all over the world in a system known as the World Wide Web (i.e.,
the Web). The documents are organized into web spaces, where a web space includes a home page and links to other
documents which may be in the local web space or in an external web space. Such links are known as hyperlinks. Docu-
ments may include moving images, text, graphical displays, and sound.

15 HTML is a form of Standard Generalized Markup Language (SGML), defined by the International Standards Organ-
ization (ISO), reference number ISO 8879:1986. HTML specifies the grammar and syntax of markup tags which are
inserted into a data file to define how the data will be presented when read by a computer program known as a browser.
The data file, which is typically stored on a Web server, includes one or more Web pages which are visited by users
who have computers which may run different browsers. When a page is visited, typically via a telephone connection,
20 HTML data is downloaded to a user's computer. The computer's browser processes the data to format a layout for the
page so the page can be viewed by the user on a computer screen.

25 An SGML document includes three parts. The first part describes the character set, or codes, which are used in the
language. The second part defines the document type, and which markup tags are recognized. The third part is known
as the document instance and contains the actual text and markup tags. The three parts may be stored in different files.
Furthermore, HTML browsers assume that files of different pages contain a common character set and document type,
so only the text and markup tags will change for different pages.

30 The base character set for HTML is Latin-1 (ISO 8859/1), which is an eight-bit alphabet with characters for most
American and European languages. The 128-character standard ASCII (ISO 646) is a seven-bit subset of Latin-1. For
simplicity and compatibility with different browsers, many Web pages include only an ASCII character set. Furthermore,
non-ASCII characters may be defined using sequences of ASCII characters. For example, the character "è" is defined
as "è".

35 HTML characters are enclosed in angled brackets to distinguish them from the page text. The characters may
appear alone, or may appear at the start and end of a field of the page text. For example, <P> indicates the start of a new
paragraph, while <I>Welcome to my home page</I> indicates the phrase "Welcome to my home page" should be itali-
cized. Generally, HTML tags provide text formatting, hypertext links to other pages, and links to sound and picture ele-
ments. HTML tags also define input fields for interactive Web pages.

The following list identifies some of the more common HTML codes and functions:

40

45

50

55

HTML Code	Description
<A>	anchor code - defines a section of text as a hyperlink or target of another hyperlink
<blockquote>	quoted text
<BODY>	main portion of page
	bold face
<!--comment-->	author comment - does not appear on page
	emphasized text, usually italicized
<HEAD>	header or title
<HR>	horizontal rule
<HTML>	denotes an HTML document
<I>	italicize
 	line break
	list item
	unordered list
	ordered list
<P>	start a new paragraph
	strongly emphasize text, usually bold face
<TITLE>	title of document
<TT>	typewriter text
<U>	underline

Moreover, there are currently three standardized levels of HTML. Level 1 defines a baseline level with which all Web browsers must be compatible. Level 2 includes the elements of level 1 in addition to tags for defining user input fields. Level 3 adds markup tags for various features such as tables, figures and mathematical equations. The levels are fully backwards compatible.

Hypertext is so-named because it allows a user to access different pages in different orders using hyperlinks, rather than in a predetermined, linear manner. Moreover, a particular hypertext application known as hypermedia includes elements other than text, such as images, video, and audio. HTML can specify links to multimedia objects. Links in an HTML hypertext page usually appear as highlighted text which is known as the anchor of the link. Moreover, an image, such as an icon, can be an anchor, which is activated, for example, by the user clicking on the icon using a mouse or other pointing device. Furthermore, images known as image maps can include a number of regions which are themselves individual anchors.

An HTML application is made available to users on the Web by storing the HTML file in a directory that is accessible to a server. Such a server is typically a Web server which conforms to a web browser-supported protocol known as Hypertext Transfer Protocol (HTTP). Servers that conform to other protocols such as the File Transfer Protocol (FTP) or GOPHER may also be used but do not support interactive HTML files.

HTTP defines a set of rules that servers and browsers follow when communicating with each other. Typically, the process begins when a user clicks on an icon in an HTML page which is the anchor of a hyperlink, or the user types in a Uniform Resource Locator (URL), described below. A connection is then made to the server at the address and port number specified by the URL. Next, the browser sends a request to retrieve an object from the server, or to post data to an object on the server. The server sends a response to the browser including a status code and the response data. The connection between the browser and server is then closed.

FTP is a file transfer protocol supported by Transmission Control Protocol/Internet Protocol (TCP/IP) protocol stacks. In particular, FTP is session oriented while HTTP is not. Consequently, unlike HTTP, with FTP, the server is required to maintain a list of active clients.

GOPHER is an indexing system that enables a user to access various Internet resources through a menu-driven system.

Other protocols include TELNET, NEWS, or MAILTO. A TELNET program allows a user to connect to another computer and use it as if the user were sitting at the keyboard of the computer. NEWS indicates that a link to a USENET newsgroup should be made, for example, to access a specific news article. MAILTO indicates an Internet Mail Protocol. If a user targets a mail type URL, the browser will open a window to allow the user to create a mail message to be delivered to the indicated e-mail address. The above protocols are standardized by the Internet Engineering Task Force (IETF) and are supported by most web browsers.

The URL is a unique address which identifies virtually all files and resources on the Internet. A URL has the form:

method://server:port/path/file#anchor.

The "method" of accessing the resource is the web browser-supported protocol, and may include, for example, HTTP, FTP, GOPHER, TELNET, NEWS, or MAILTO. The "server:port" indicates the name of the server which is providing the resource, and is alternatively known as the Internet domain name. For example, many companies will use their company name as part of the server field. The port designation is the port number on the server, but is usually not used since a default port is assumed. The "path" indicates the directory path to the resource. The file indicates the file name of the resource. The "anchor" indicates the named element in the HTML document. Not all fields are required.

For example, consider the following URL:

<http://www.company.com/news/june.html>.

The access method is HTTP, the server is www.company.com, there is no port specified, the path is news, the file is june.html, and there is no anchor. Examples of FTP, GOPHER, TELNET, NEWS, and MAILTO URLs are, respectively:

<ftp://ftp.uu.net/doc/literary/obi/World.Factobook>;
<gopher://gopher.micro.umn.edu/>;
<telnet://compuserve.com/>;
 news:alt.cows.moo; and
<mailto:president@whitehouse.gov>.

Moreover, interactive Web applications use a client-server standard known as the Common Gateway Interface (CGI). A CGI program generates HTML in real-time to produce a dynamically generated Web page. CGI programs, or scripts, perform various Web functions. For example, a CGI program known as Imagemap processes imagemaps for servers. Moreover, HTML forms often require CGI scripts to process user-entered information. CGI scripts act as an interface between Web servers and other computer applications, including database managers and order processing systems.

In view of the rapidly increasing use of Web pages and other resources which are created using HTML, it would be advantageous to provide a scheme for adapting such resources for use by consumers and others via television or other broadcast or prerecorded media. In particular, it would be desirable to provide graphical and textual displays for use with a television for educational and entertainment purposes. Such displays should be compatible to the extent possible with existing transmission and receiving equipment including set-top decoders and the like, and should further be compatible with current communication protocols such as those for transmission of digital television signals via satellite and/or cable plants.

Furthermore, the system should provide the capability to control various television functions such as channel selection, volume, and language preference, in addition to interactive operations such as the purchase of near-video-on-demand programming or other home shopping products or services, as well as non-television appliance functions such as for associated audio equipment, or, lastly, for a home heating and air conditioning system, security system or the like. The present invention provides a system having the above and other advantages.

SUMMARY OF THE INVENTION

In accordance with the present invention, an apparatus and method are presented for providing textual and graphical displays using hypertext markup language (HTML) for use with a television decoder. Additionally, the invention allows the control of various television functions, such as channel selection, volume, or language preference, in addition to non-television functions, such as programming of an automated home heating system or the like. With the invention, the vast HTML resources of the Internet may be adapted for use in the television environment for entertainment, educational or informational purposes.

A method for providing display data for use with a television includes the step of providing a data signal which includes display data which is coded according to a hypertext markup language. The display data signal is processed

to provide a signal suitable for reproduction on a television or similar video display appliance. In particular, the display data may allow a user to invoke hyperlinks to view different parts of the display data, such as different display data pages. The display data may also be used to allow a user to invoke function calls which control a function which may or may not be related to the television or an associated programming service signal.

Moreover, the display data may provide information regarding an associated video programming service signal, such as a network television broadcast signal. The display data may provide information on a featured movie or other special presentation, or may provide a programming guide with program scheduling information. The display data may include a viewer input field which allows viewing of the associated video programming service signal on a fee basis. For example, when an interactive capability is provided between a television decoder and a cable system headend or other programming service provider station, a user may enter a password which authorizes the purchase of pay-per-view programming.

Furthermore, the display data signal and associated video programming service signal may be processed for display on the television in an overlay (e.g., combined) manner. For example, the display data may be provided in a border region, while the video programming service signal is provided in an inset region, or vice-versa. Alternatively, a split-screen, picture-in-picture, or other configuration may be provided.

The display data may allow a user to invoke hyperlinks and function calls to view display data and/or the associated video programming service signal. For example, the display data may be used to provide a screen with buttons or graphical or textual devices which may be selected by a user through a remote control. When a particular button is selected, a corresponding hyperlink and/or function call may then cause the display of a screen including additional display data (e.g. an additional HTML page) and/or a particular video programming service channel, and may further control a particular television function, such as volume, muting, or the like, or a non-television function, as mentioned.

A corresponding apparatus is also presented.

Additionally, a receiver is presented for providing display data for use with a television. The receiver may be a television decoder (e.g., set-top box) which has an input for receiving a data signal comprising the display data which is coded according to a hypertext markup language. Furthermore, a display data processor is included for processing the display data signal to provide a signal suitable for reproduction on the television.

The receiver also has an input for receiving a video programming service signal, and a video processor for processing the video programming service signal. This processor may perform video decompression processing. The display data provides information regarding the video programming service signal.

A user command processor in the receiver is operatively associated with the display data processor for receiving user commands for allowing selective viewing of the display data. The user commands may be provided, for example, by an infrared remote control transmitter, or a mouse or other pointing device. Moreover, the user command processor may work in conjunction with the video processor for receiving user commands for allowing selective viewing of the video programming service signal. That is, commands entered by a user may be received by the user command processor and sent to the video processor to provide the appropriate action. In this way, the user can select the programming service and display data he wishes to view, and optionally a particular viewing format such as, for example, aspect ratio (e.g., movie box format), color settings, brightness, contrast, or other display options.

The display data may include URLs which represent function calls which are implemented in accordance with the user command processor for allowing selective control of functions of the television or a non-television related device. For example, a display data screen may include a button which initiates a function call for changing the volume of the television or selecting a language preference of an available soundtrack or closed captioned signal. Another button may initiate a function call for setting an automated heating and air conditioning system in a household, for instance. Moreover, the relationship between the syntax of the function calls and the resulting functions may be determined according to a uniform resource locator syntax disclosed herein.

BRIEF DESCRIPTION OF THE DRAWINGS

FIGURE 1 is a block diagram of a television transmission system in accordance with the present invention.

FIGURE 2 is a block diagram of a television receiver in accordance with the present invention.

FIGURE 3 is an illustration of a screen with HTML/HTVP display data in accordance with the present invention.

FIGURE 4 is an illustration of a screen with HTML/HTVP display data combined with a video programming service signal in accordance with the present invention.

FIGURE 5 is an illustration of a screen with HTML/HTVP display data for selecting television and non-television appliance function calls in accordance with the present invention.

DETAILED DESCRIPTION OF THE INVENTION

A method and apparatus are presented for providing textual and graphical displays using hypertext markup lan-

guage (HTML) for use with a television decoder. Additionally, HTML is adapted for use in controlling various television and other functions in a hypertext markup language protocol defined herein as "HTVP" HTVP may be considered to be a type of HTML which is used in implementing the functions in accordance with the present invention.

The HTVP concept, which is a framework upon which future protocols can be developed and defined, builds upon the methods used by HTML pages for URL syntax. As mentioned, a URL, or Uniform Resource Locator, typically defines three things: a communication protocol, a logical access path to be used by that protocol, and the name of an object. Example object types include bitmap images, other HTML pages, and files of virtually any type or format.

The HTVP URL type represents a new function associated with URLs within the HTML syntax. The general form of an HTVP URL in accordance with the present invention is defined as:

```
htvp://function_domain/receiver_function?function_parameters.
```

The "function_domain" field identifies the family of receiver functions of which the identified function is a part. A standard or default function_domain can be defined as "std." The std function may define a group, or family, of common functions which can be made available as an open standard for use by the public at large. Furthermore, a proprietary function_domain may also be defined which is recognized only by a receiver of a particular company. For example, a function_domain of "company" may be used. A receiver that does not recognize functions in a certain domain will ignore the URL in which they are referenced.

The "receiver_function" field identifies a specific receiver function or application program interface (API). For example, when the receiver is a television decoder (e.g., set-top box), functions may include "channel_up," "select_virtual_channel," "buy_program," "buy_package," "link_to_page," "VIEW," "select_language," "mute_audio" and so forth. These receiver_function fields instruct the decoder to adjust the television display and/or sound as indicated.

The "function_parameters" field provides an optional list of parameters to be passed to the receiver to execute functions therein. These parameters may be used to select sub-functions, or provide fixed parametric values. For example, when the receiver_function field is "select_virtual_channel," a required parameter would be the channel number for which the programming should be displayed. In this case, a URL that would acquire virtual channel 444, for example, would have the syntax:

```
htvp://std/select_virtual_channel?channel=444.
```

Thus, the function_parameters field is "channel=444".

Furthermore, the function_parameters field may include more than one parameter, where each parameter is of the form:

parameter_ID=parameter_value, and a division between parameters is indicated by an ampersand (&). For example, a URL identifying an HTVP receiver_function called "function_1" that has three parameters, "parm1," "parm2" and "parm3", with respective values "value1," "value2," and "value3", has the syntax:

```
htvp://std/function_1?parm1=value1&parm2=value2 &parm3=value3.
```

For example, function_1 may allow a user to purchase various products or services via an interactive cable television network, where parm1, parm2 and parm3 indicate the purchase number, and value1, value2 and value3 indicate the selected items.

Moreover, the function_parameters field may be incorporated into a URL for an HTML page following the filename field. Provision may be made for interactivity such that a user can interact with a processor which operates using commands similar to a Web browser. That is, the user can enter or select a function_parameters field using an input device such as a mouse, other pointing device, infrared transmitter, or keyboard. The processor receives the function_parameters field entered, appends the field to a URL, and transmits a request back to a server.

For example, a user may wish to retrieve stock quote information using the television. In this case, assume the relevant Web site is "www.stocks.com," the relevant server file is "quotes," and the user-entered function_parameters field will be the symbol for a particular stock (e.g., GM) which is recognized by the Web site, e.g., "tick=GM," where parameter_ID=tick, and parameter_value=GM. In this case, the processor transmits the following URL to the Web site server:

```
http://www.stocks.com/quotes?tick=GM.
```

Here, the "?" is specified by the definition of the HTML FORM command as the separator between the name of the program on the server that executes the database search ("quotes" in this case) and the parameters passed into it (e.g.,

tick=GM). The syntax used to delimit the parameters and their values is defined in the same manner as the POST method within the HTML FORM type.

Generally, the hypertext markup element FORM is used to define an area of a page which contains objects for input from the viewer. The objects may be input fields and other interactive objects, such as pop-up menus, check boxes and buttons. There can be any number of forms on a page, each of which begins and ends, respectively, with the tags <FORM> and </FORM>. The beginning FORM tag takes an ACTION attribute that specifies the action to take with the user-entered information. The ACTION attribute takes a URL as its value which can be either the URL of a CGI script or a MAILTO URL. For example, when the input field "tick=GM" is received, the action is to send a form HTML page which provides the requested information, including the stock price. The POST markup element indicates that the FORM content is in a standard configuration.

FIGURE 1 is a block diagram of a television transmission system in accordance with the present invention. The system includes a transmitter side, shown generally at 100, and a receiving side, shown generally at 150. The transmitting side 100 includes a programming services function 105, which comprises video and audio programming services from network television stations and the like. The programming services audio/video data, which may be carried as digital data, is multiplexed with HTML/HTVP data from an HTML/HTVP data function 110. The HTML/HTVP data may be related to some or all of the programming services and include, for example, display screens which allow a user to purchase programming or other products or services, or provide information on the available programming services, such as movie reviews, programming guides, and so forth. Moreover, the HTML/HTVP data may provide unrelated information such as stock quotes, weather information, airline travel schedules, or virtually any resource which is constructed with HTML. Moreover, HTML/HTVP data may include information for controlling various television functions.

The programming services data and the HTML/HTVP data are provided to a multiplexer 115, which outputs a corresponding combined signal to a transmitting antenna 120. The transmitting antenna transmits a signal to a receiving antenna 155 via a satellite 125. The signal may be carried as a packetized digital transport stream which conforms to, for example, the Moving Pictures Experts Group-2 (MPEG-2) standard.

The transport stream is provided to a cable system headend 160, where the data may be processed for distribution to cable system customers. For example, various decryption/encryption and scrambling/descrambling operations may take place. Additionally, insertion of local commercials and programming may occur. Moreover, at the cable system headend 160, it is possible to provide HTML/HTVP data in addition to, or in lieu of, the data provided by function 110 using means not shown. For example, HTML/HTVP data from local businesses and broadcasters may be provided. Moreover, the transport stream may be broadcast directly to the user via a direct broadcast satellite system, microwave broadcast system, or the like.

The cable system headend 160 distributes the transport stream to subscribers via representative hubs 165 and 170, and spokes as shown. At a subscriber's home 180, a decoder receives the transport stream, decodes it, and provides an audio and video signal for reproduction on a television 188 or similar video display appliance.

FIGURE 2 is a block diagram of a television receiver in accordance with the present invention. The decoder, shown generally at 180, corresponds to the decoder of FIGURE 1. The decoder 180 receives the transport stream from the cable headend, or alternatively, directly from a satellite in a direct broadcast satellite communication scheme. The transport stream is demultiplexed at demultiplexer 205 to recover the HTML/HTVP data and programming service audio/video data as shown. The programming service data is parsed at parser 220 and provided to a memory manager 225. The memory manager, which may include a central processing unit, controls the decoding of the audio and video data by interacting with a video decompression processor 240, an audio decompression processor 245 and a memory 235.

The memory 235, which may comprise a dynamic random access memory (DRAM), is used to temporarily store the video pictures prior to decoding and presentation of the video on the television screen. The video decompression processor 240 provides a variety of processing functions, such as error detection and correction, motion vector decoding, inverse quantization, inverse discrete cosine transformation, Huffman decoding and prediction calculations, for instance. After being processed by the decompression processor 240, the video pictures are output to a combiner 250. Alternatively, the decoded data may be temporarily stored in the memory 235.

The audio decompression processor 245 processes audio data using, for instance, inverse quantization, Huffman decoding, and spectral shaping algorithms.

The memory manager 225 receives commands from a user command processor 230, which, in turn, receives a user command via terminal 232. The user command may be input, for example, by a mouse or other pointing device, a keyboard, or an infrared remote control or the like. The user command processor 230 can provide a user request signal via the cable plant or a telephone line to the cable headend to achieve an interactive capability, and can further provide a control signal to the combiner 250. Additionally, means (not shown) may be used for maintaining a record of user commands which is periodically transmitted to the cable headend or other broadcast station such as in a store-and-forward routine. The memory manager 225 also receives commands from an HTVP processor 215.

The HTML/HTVP processor 215, which communicates with a memory 210, receives the HTML/HTVP data from the

demultiplexer 205. The processor 215 may include a central processing unit which implements an HTML-based code which is analogous to a Web browser. The HTML/HTVP processor also receives commands from the user command processor 230. HTML/HTVP display data provided by the processor 215 is then provided to the combiner 250, where it may optionally be combined with the video data from processor 240 to produce a graphical display on a television screen wherein the display data overlays the programming service data, or vice-versa. The memory 210 may include service map data which allows an HTML/HTVP page displayed on the television screen to link to other HTML/HTVP pages. Moreover, note that the HTML/HTVP code may be downloaded to the decoder 180 via the transport stream or a telephone line (not shown), and/or installed locally, e.g., via a smart card.

FIGURE 3 is an illustration of a screen with HTML/HTVP display data in accordance with the present invention. The screen, shown generally at 300, comprises an HTML/HTVP page which was provided using the HTML/HTVP display data from processor 215 in FIGURE 2. The screen 300 can include a variety of textual and graphical displays in addition to providing an interactive capability. For example, the screen 300 includes buttons 305, 310, 315, 320, 335, 340 and 345, which define hyperlinks to other HTML/HTVP pages or function calls. The buttons may be selected by the user via a pointing device, infrared remote control, or the like. The buttons may include text and/or graphics, such as icons, which inform and entertain the user.

Button 305 informs the user that by pressing the "←" key on the keypad of a remote control, for instance, a previous HTVP display page may be selected for viewing. Referring again to FIGURE 2, when the user command processor 230 receives the user's command, it passes it to the HTVP processor 215 to cause the processor to provide the appropriate display data to the television. Moreover, the user command processor 230 may provide a signal to the memory manager 225 to provide audio and/or video of the programming service in conjunction with, or in lieu of, the HTVP data.

Button 310 informs the user that by pressing the "→" key, a next page may be selected for viewing. Button 315 informs the user that by pressing the "*" key, a page which includes a programming guide may be selected for viewing. Button 320 informs the user that by pressing the "?" key, a page with helpful information may be selected for viewing. Button 335 informs the viewer that by pressing the "1" key, a page with a movie review may be viewed. Button 340 informs the viewer that by pressing the "2" key, a page with information on the movie's leading actress may be viewed. Button 345 informs the viewer that by pressing the "3" key, a page with information on tomorrow's featured movie may be viewed.

Additionally, the screen 300 includes a region 325 which does not initiate a hyperlink but provides relevant text and/or images, such as the title of a featured movie. Field 330 is an HTVP input field which provides interactive capability. Interactive cable television systems are becoming increasingly common. Such systems allow a subscriber to transmit signals from their homes to the cable system headend for ordering pay-per-view movies, sports and other programming services, including near-video-on-demand (NVOD), to purchase goods or services through a home shopping channel, or to participate in surveys, contests and the like. Alternatively, if the cable plant does not provide such an interactive capability, the television decoder may be coupled to a telephone line for automatically dialing a computer which maintains billing and authorization records, e.g., in a store-and-forward routine. In either case, an addressable decoder is required.

In particular, input field 330 allows a user to enter a password, for example, using the keypad on a handheld remote control, to authorize the purchase of a pay-per-view program. Referring again to FIGURE 2, when the user command processor receives the password, it will transmit it to the cable headend or other location for authorization. When the request is authorized, the corresponding programming service and/or HTML/HTVP data will be transmitted to the decoder 180 in the manner discussed.

FIGURE 4 is an illustration of a screen with HTVP display screen combined with a video programming service signal in accordance with the present invention. The screen, shown generally at 400, includes a combination, or overlay, of HTML/HTVP display data, and a programming service video. Techniques for providing multiple images in a television display (e.g., picture-in-picture) are well known in the art. Any such well known technique may be used to provide the combined display of FIGURE 4.

In the example shown, the screen 400 includes a sub-region, or inset, 410 in which a video programming service is displayed. Elements 305, 310, 315, 320 325 and 330 are the same as discussed in connection with FIGURE 3. This screen configuration allows the user to view the programming service video, which may be the current channel the user had been viewing, while also viewing the HTML/HTVP display data in the surrounding region 420 to learn about other available programming options. Alternatively, the sub-region 410 may provide a free, introductory preview of a pay-per-view program, while the HTML/HTVP display in the surrounding region 420 provides information on ordering the entire program.

Moreover, the screen 400 may provide a HTML/HTVP display which is updated real-time with information that is unrelated to the video image present in sub-region 410. For example, HTML/HTVP data may provide stock prices or weather information, while the sub-region 410 allows the user to independently view any available programming service. In a further alternatively, the HTML/HTVP display may be provided in the sub-region 410 as an overlay to the programming service video which is present in the surrounding region 420. Other variations and combinations are

possible, including split-screen and picture-in-picture.

Furthermore, the user may provide a command for switching or otherwise modifying the relative positions of the HTML/HTVP display and the programming service video. The user command processor 230 of FIGURE 2 will be responsive to the user's command in sending a control signal to the HTML/HTVP processor 215, memory manager 225, and/or the combiner 250 for controlling the output signal to the television.

The HTVP concept can be extended to various applications. For example, it can provide a text service, which is a virtual channel that provides the user with a number of inter-linked text/graphics screens. As with teletext (e.g., closed captioning), the source data for each screen is broadcast in a carousel, or cyclic, manner such that data for a complete page is transmitted in one or more segments over a number of successive transmission cycles. The decoder must wait until the desired page is transmitted in full. When the full page is captured, it is stored in memory, such as a random access memory (RAM) (e.g., memory 210), for subsequent processing and display.

In one application, HTVP can provide a report back feature. In this case, a standard application program interface (API) can be used. An API is a set of predetermined functions for building an application. For example, an API can be used that defines a particular design, color, or pattern. Moreover, an API can be used to build an HTML page which include a button that, when selected, causes a parameter string to be processed by a store-and-forward routine in the decoder. For example, an API could include a telephone number to call and a message to deliver. An option could allow either immediate reporting or store and forward operation.

Another option could require correct entry of a password to enable the function. Though not part of the parameter list, the data report can include the unit address for informing the upstream equipment of the source of the request or report. Thus, for example, a decoder could automatically report diagnostic information to a cable system headend when the decoder is not operating properly.

Various other functions can be supported by the HTVP concept. In the following list, the first column lists a proposed HTVP syntax, while the second column explains the associated function. The implementation of a function using the suggested syntax in accordance with the present invention is referred to as a "function call." The HTVP commands can be linked to appropriate buttons or other graphical displays on a television screen interface to facilitate selection.

Syntax	Function
htvp://std/channel_down	Tunes to the next lower channel number
htvp://std/channel_up	Tunes to the next higher channel number
htvp://std/getchannel_number	Returns an ASCII text string representing the channel number
htvp://std/getchannel_name	Returns an ASCII text string representing the channel name
htvp://std/mute	Enables audio muting
htvp://std/unmute	Disables audio muting
htvp://std/volume_down	Lowers the audio volume by one level
htvp://std/volume_up	Raises the audio volume by one level
htvp://std/program_name	Returns the program name
htvp://std/purchase?item=xxx	Records a purchase of an item specified with an item identifier. Can be used for impulse pay per view or items unrelated to the current material being viewed.
htvp://std/skip_back	Changes channel to a theater of an NVOD program that is earlier than the current channel.
htvp://std/set_language?lang =xxx:[audio[subtitle]	Set the language preference
htvp://std/ir_blast?string=x xx	Transmit the quoted string (xxx) using an infrared blaster

In the table above, an "infrared blaster" refers to a secondary infrared transmitting device which transmits an infrared signal in response to an infrared or other command received by a user. For example, a user may transmit an infrared command from a hand held transmitter to a set-top decoder to view a particular television channel. The decoder will execute the a function call which switches the television to the appropriate channel, and also transmit an infrared signal for example, to a VCR to cause the VCR to begin recording, or to an audio component to cause the component to operate in a particular mode (e.g., surround sound).

Moreover, the HTML/HTVP concept may be extended to allow the viewer to control household appliances other than a television when the appliances are linked to the decoder. For example, an HTVP page may provide hyperlinks, input fields, and function calls which allow the viewer to program a household security system, heating and cooling system, fire alarm system, or the like for convenience or energy conservation purposes.

5 For example, FIGURE 5 is an illustration of a screen with HTML/HTVP display data for selecting function calls in accordance with the present invention. Both television and non-television function calls are provided. The screen, shown generally at 500, includes a "TV Control" field 510, a "Home Systems" field 530, and an "Audio Center" field 550. The TV Control field 510 allows a user to control various television related functions. In the illustration shown, the aspect ratio may be controlled by a user-selectable button 512 for a standard (std) aspect ratio, and a button 514 for a "movie" aspect ratio. The tint level of the video image is represented by a bar 516, and the brightness is represented by a bar 518.

10 For example, when the aspect ratio is changed, a user command is provided to the user command processor 230 which then instructs the memory manager 225 and video decompression processor 240 to provide the video signal with the appropriate aspect ratio. This is an example of a television-related function call since a television function is being controlled via the use of a HTML/HTVP display screen.

15 In the Home Systems field 530, a security system such as a user's home security system includes an "on" button 532 and an "off" button 534. A heating system may be controlled using a "set" button 536 or an "auto" button 538. The set button 536 allows the user to select customized settings, while the auto button 538 may provide a default profile. In either case, the user provides a command to the user command processor 230 which then provides an appropriate signal to the security or heating system. Referring to FIGURE 2, the decoder 180 can be provided with interface means (not shown) for providing an appropriate control signal to the non-television system which is to be controlled via the screen 500. This is an example of a non-television related function call since a non-television function and/or appliance is being controlled via the use of a HTML/HTVP display screen.

20 A non-television function or appliance is defined herein to refer to any device, apparatus or system other than a television, and includes, for example, a heating or air conditioning system, a security system, an air filtering system, or household appliances such as a water heater, clothes washing machine, or dishwasher. Additionally, the term encompasses electronic equipment such as audio amplifiers, filters, and recording devices such as those which use digital audio tapes, magnetic and optical cassette tapes, and recordable compact discs, to reproduce, record or otherwise process the audio portion of a programming service signal. The term further encompasses analogous electronic equipment for recording or otherwise processing the video portion of a programming service signal outside of the television, including those which use digital video discs and laser discs. Additionally, a decoder such as the decoder 180 of FIGURE 2 may be considered to be a non-television appliance.

25 A non-television function or appliance is defined herein to refer to any device, apparatus or system other than a television, and includes, for example, a heating or air conditioning system, a security system, an air filtering system, or household appliances such as a water heater, clothes washing machine, or dishwasher. Additionally, the term encompasses electronic equipment such as audio amplifiers, filters, and recording devices such as those which use digital audio tapes, magnetic and optical cassette tapes, and recordable compact discs, to reproduce, record or otherwise process the audio portion of a programming service signal. The term further encompasses analogous electronic equipment for recording or otherwise processing the video portion of a programming service signal outside of the television, including those which use digital video discs and laser discs. Additionally, a decoder such as the decoder 180 of FIGURE 2 may be considered to be a non-television appliance.

30 In the Audio Center field 550, a surround sound level is represented by a bar 552, and a special effects switch can be controlled by an "on" button 554 and an "off" button 556. In this case, the user provides a command to the user command processor 230 which then provides an appropriate signal to the audio equipment. This is another example of a non-television related function call.

35 In the examples of FIGURE 5, various other display options are possible according to the information to be conveyed and the desired screen appearance. Moreover, the selection of a particular button or other interface device, such as the set button 536 in the Home Systems field 530 may select a hyperlink to another display data screen with additional function call options. For example, after selecting the set button 536, a screen may be displayed which allows the user to set the desired temperature at different times of the day, different days of the week, and/or at different regions of the home or business which is being heated.

40 Moreover, the decoder 180 may be provided with timing means (not shown) for maintaining the selected schedule. Thus, a heating system which is not programmable or otherwise automated can be controlled in an automated manner via a television screen using HTML/HTVP data. Other appliances, for example, such as a dishwasher, hot water heater, or coffee maker, may also be controlled in this manner. In any case, the HTML/HTVP data provides the user with a display which presents the available programming options, and responds to the user commands by implementing function calls that send the appropriate command signal to the television or non-television related appliance.

45 In view of the above, it should be appreciated that the present invention provides an apparatus and method for providing textual and graphical displays using hypertext markup language (HTML) for use with a television decoder. Additionally, HTML is adapted for use in controlling various television and non-television related functions with a syntax referred to as HTVP. Accordingly, the invention provides entertainment, educational, and informational displays for television viewers. Moreover, the invention allows 1 viewer to execute hyperlinks and function calls for viewing additional HTML/HTVP pages and/or programming service video, or for activating various television, non-television, or decoder functions. Moreover, the invention is compatible with virtually any type of programming service, including television, information services such as stock prices and weather data, and audio/video programming implemented in software including games and other programming.

55 Although the invention has been described in connection with various specific embodiments, those skilled in the art

will appreciate that numerous adaptations and modifications may be made thereto without departing from the spirit and scope of the invention as set forth in the claims.

Claims

5

1. A method for providing display data for use with a television, comprising the steps of:

10

providing a data signal comprising said display data which is coded according to a hypertext markup language; recovering said data signal from said data stream; and processing said data signal to provide a signal suitable for reproduction on the television; wherein said display data allows a user to invoke function calls for controlling selected functions of at least one of a television and a non-television appliance.

15

2. The method of claim 1, wherein:

said display data allows a user to invoke hyperlinks for viewing selected portions of said display data.

20

3. The method of one of the preceding claims, wherein:

said display data allows a user to invoke function calls for viewing selected portions of an associated video programming service signal.

25

4. The method of one of the preceding claims, wherein:

said display data provides information regarding an associated video programming service signal.

30

5. The method of one of the preceding claims, wherein:

said display data provides a viewer input field for allowing viewing of an associated video programming service signal on a fee basis.

35

6. The method of one of the preceding claims, comprising the further step of:

processing said data signal and said associated video programming service signal for display on the television in an overlay manner.

40

7. The method of one of the preceding claims, wherein:

said data signal and an associated video programming service signal are carried in a digital transport data stream.

45

8. An apparatus for providing display data for use with a television, comprising:

means for providing a data signal comprising said display data which is coded according to a hypertext markup language; means for recovering said data signal from said data stream; a processor for processing said data signal to provide a signal suitable for reproduction on the television; and means responsive to said display data for allowing a user to invoke function calls for controlling selected functions of at least one of a television and a non-television appliance.

50

9. The apparatus of claim 8, wherein:

said display data allows a user to invoke hyperlinks for viewing selected portions of said display data.

55

10. The apparatus of one of claims 8-9, wherein:

said display data allows a user to invoke function calls for viewing selected portions of an associated video programming service signal.

11. The apparatus of one of claims 8-10, wherein:

said display data provides information regarding an associated video programming service signal.

5 12. The apparatus of one of claims 8-11, wherein:

said display data provides a viewer input field for allowing viewing of an associated video programming service signal on a fee basis.

10 13. The apparatus of one of claims 8-12, further comprising:

a combiner for combining said data signal and an associated video programming service signal for display on the television in an overlay manner.

15 14. The apparatus of one of claims 8-13, wherein:

said data signal and an associated video programming service signal are carried in a digital transport data stream.

20 15. A receiver for providing display data for use with a television, comprising:

an input for receiving a data signal comprising said display data which is coded according to a hypertext markup language;

25 a display data processor for processing said data signal to provide a signal suitable for reproduction on the television; and

a user command processor operatively associated with said display data processor for receiving user commands and invoking corresponding function calls for controlling selected functions of at least one of a television and a non-television appliance.

30 16. The receiver of claim 15, further comprising:

an input for receiving a video programming service signal; and
a video processor for processing said video programming service signal; wherein:
said display data signal provides information regarding said video programming service signal.

35 17. The receiver of claim 16, wherein:

said video processor is responsive to said user command processor for invoking said function calls.

40 18. The receiver of one of claims 15-17, wherein:

said display data processor is responsive to said user command processor for allowing a user to invoke hyperlinks for viewing selected portions of said display data.

45 19. The receiver of one of claims 15-18, wherein said display data provides a viewer input field for allowing viewing of an associated video programming service signal on a fee basis.

20. The receiver of one of claims 15-19, wherein:

50 a relationship between said function calls and said selected functions is determined according to a uniform resource locator syntax.

55

FIG.1

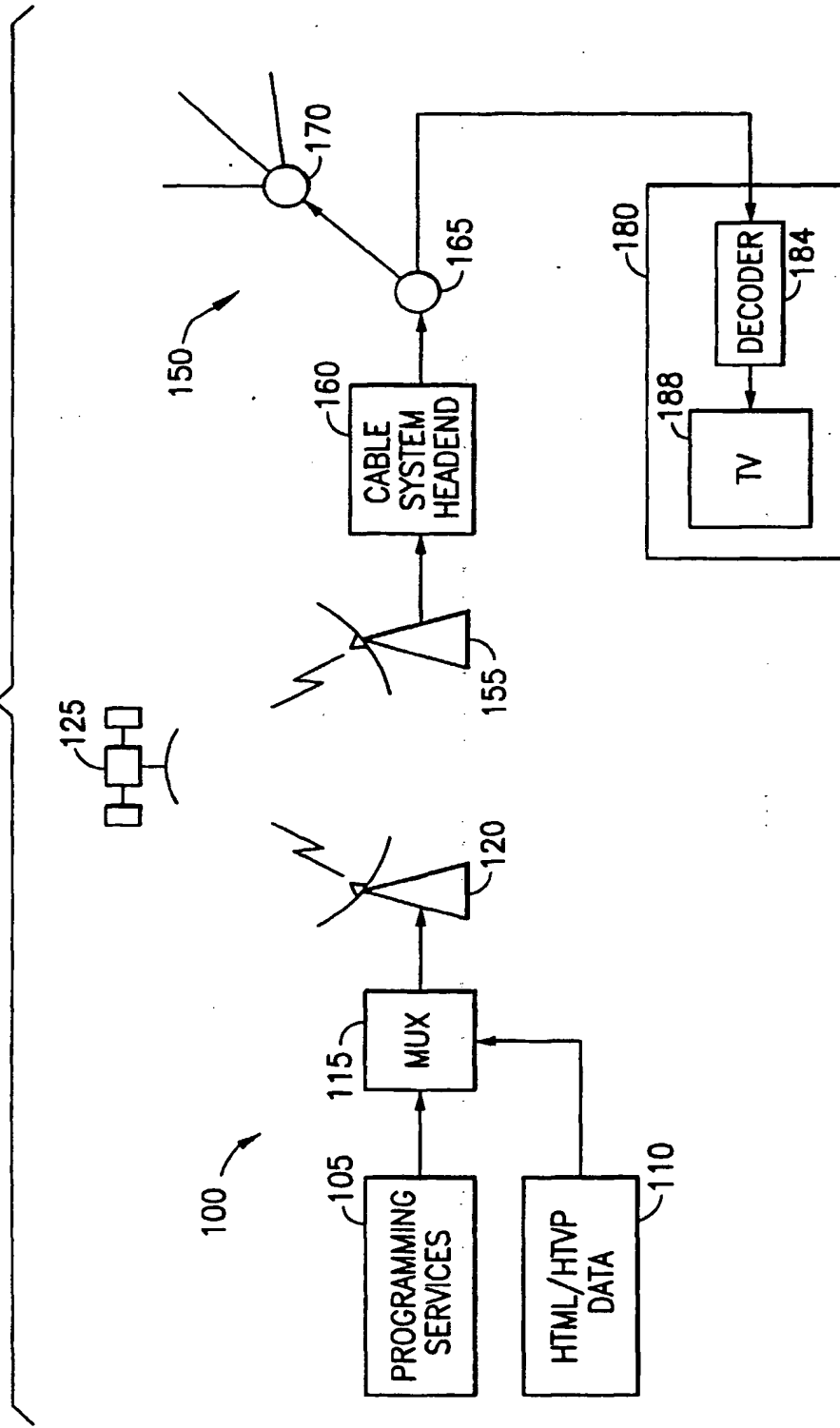

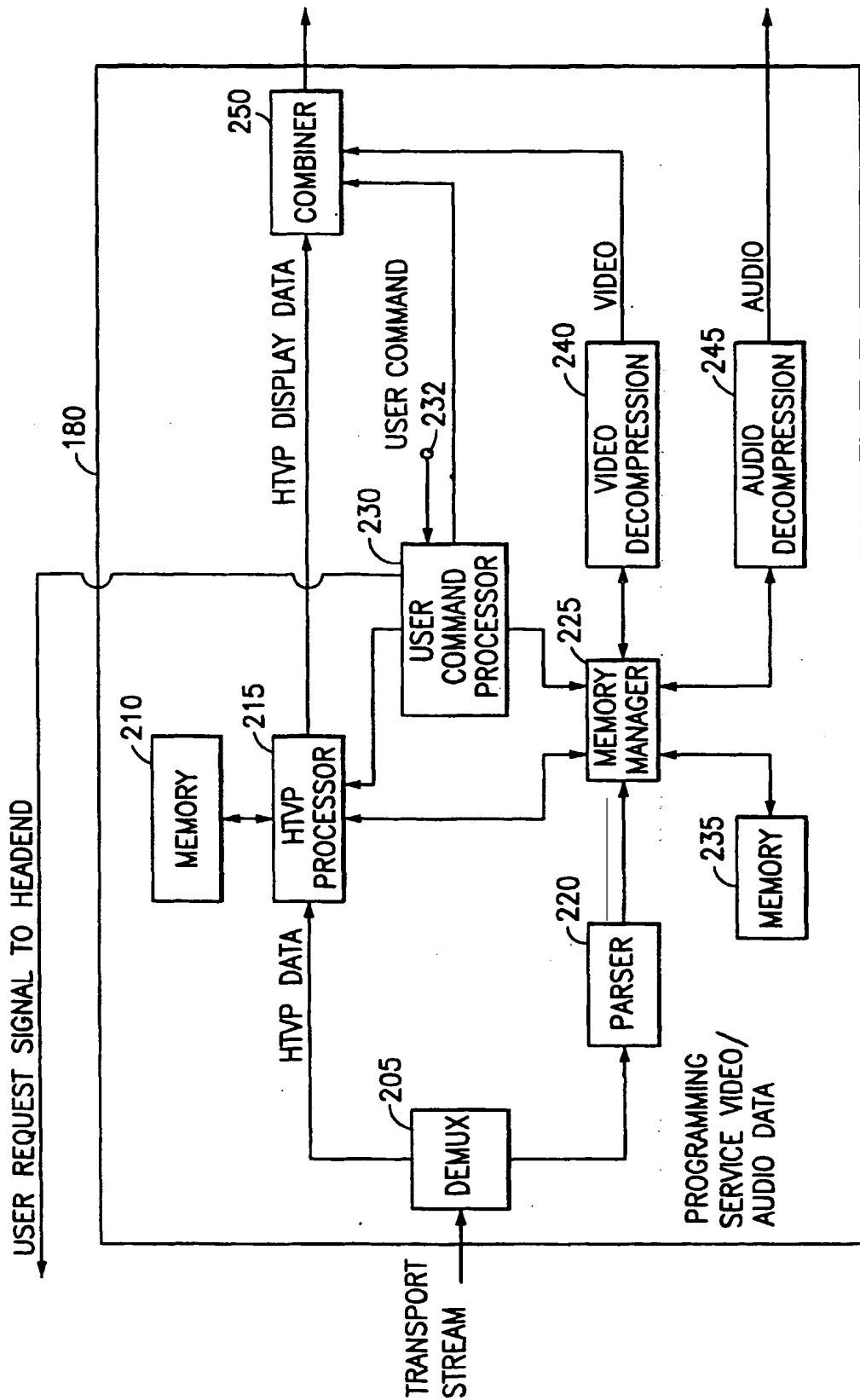

FIG.2

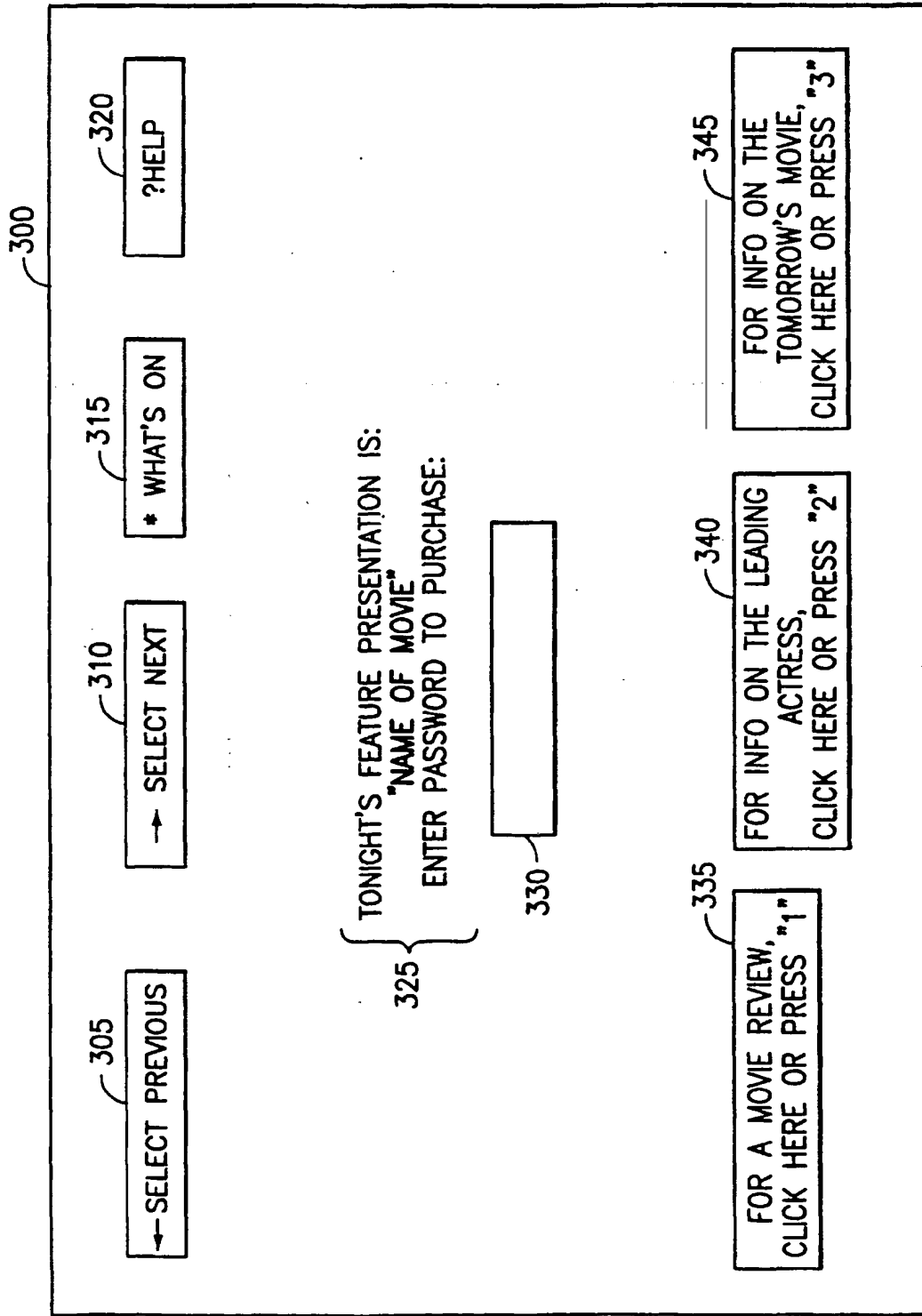

FIG.3

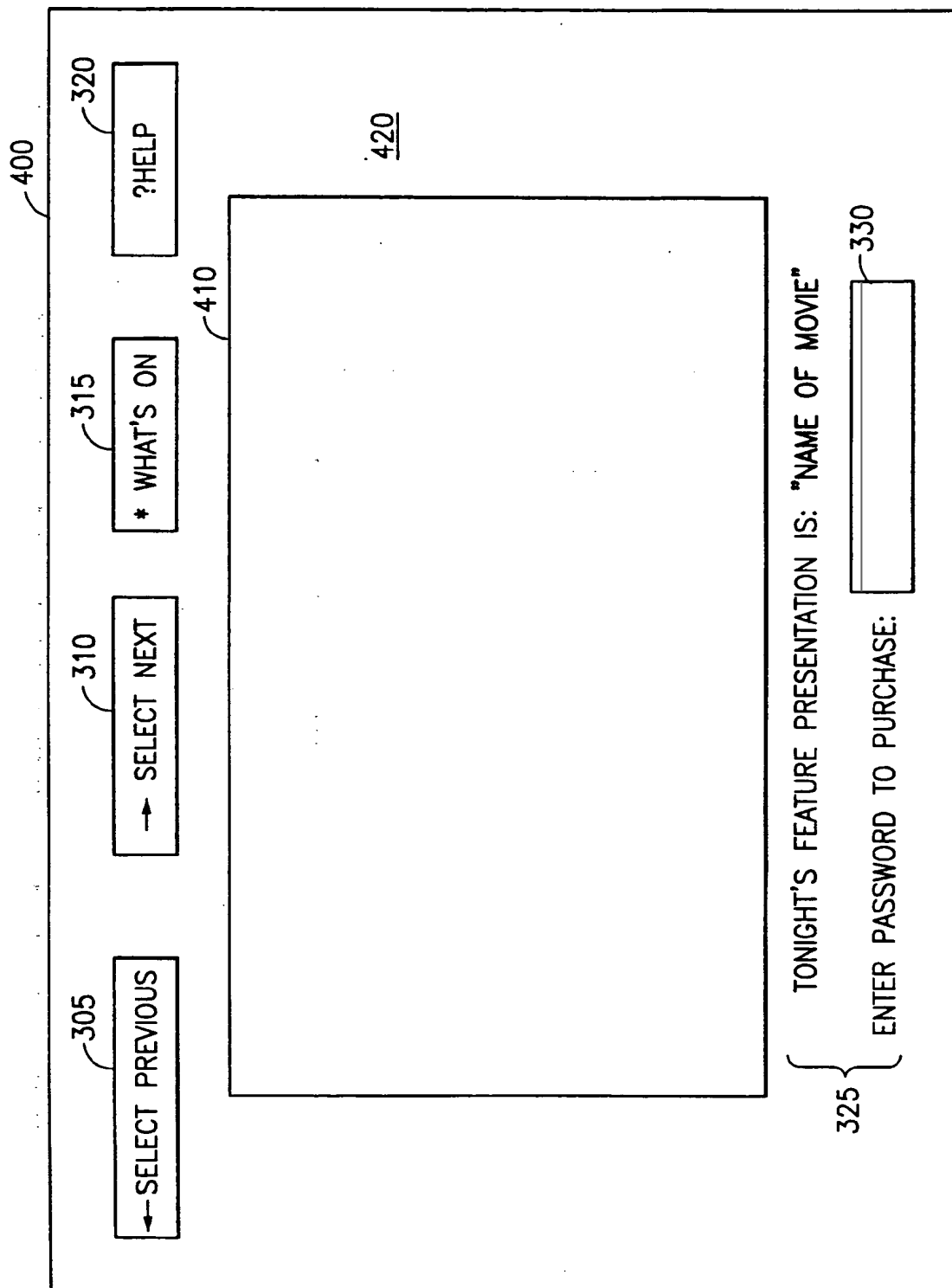

FIG.4

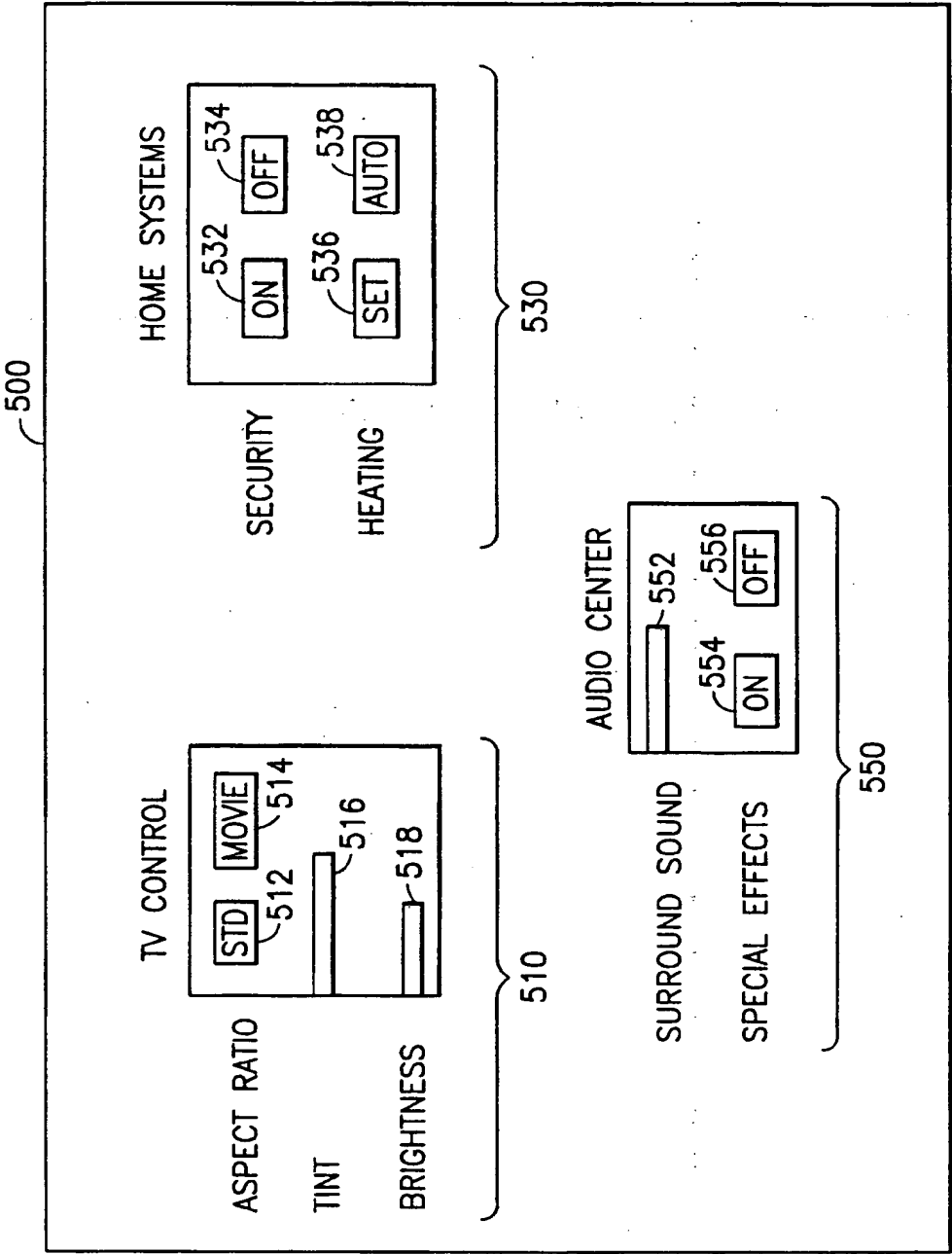
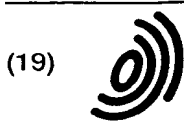

FIG.5

This Page Blank (uspto)



Europäisches Patentamt
 European Patent Office
 Office européen des brevets



(11) EP 0 837 599 A3

(12) EUROPEAN PATENT APPLICATION

(88) Date of publication A3:
 15.09.1999 Bulletin 1999/37

(51) Int. Cl.⁶: H04N 5/00

(43) Date of publication A2:
 22.04.1998 Bulletin 1998/17

(21) Application number: 97117900.7

(22) Date of filing: 16.10.1997

(84) Designated Contracting States:
 AT BE CH DE DK ES FI FR GB GR IE IT LI LU MC
 NL PT SE
 Designated Extension States:
 AL LT LV RO SI

(72) Inventors:
 • Eyer, Mark K.
 San Diego, California 92131 (US)
 • Field, Michael
 San Diego, California 92130 (US)

(30) Priority: 21.10.1996 US 734681

(74) Representative:
 Hoeger, Stellrecht & Partner
 Uhandstrasse 14 c
 70182 Stuttgart (DE)

(71) Applicant:
 General Instrument Corporation
 Horsham, Pennsylvania 19044 (US)

(54) Hypertext markup language protocol for television display and control

(57) Textual and graphical displays are provided on a television screen using a hypertext markup language (HTML). On-screen display devices allow a user to invoke hyperlinks to different pages of HTML-coded data in addition to function calls for controlling television and non-television appliance functions. A method provides HTML-coded display data which is processed to provide a signal suitable for reproduction on a television. The display data may provide information on a featured movie (325) or other presentation of an associated video programming service signal such as a network television broadcast (315). Function calls (232, 510, 530, 550) allow the control of various television functions and programming options, such as the pur-

chase of pay-per-view programming (330), or television display options such as aspect ratio (512, 514), channel, brightness (518), picture-in-picture, or split-screen. Non-television appliances which may be controlled with function calls include audio equipment which is associated with the programming service (e.g., surround sound (552), filtering (554, 556)) in addition to, for instance, a home heating and air conditioning system (536, 538) or other household appliances (532, 534). The invention allows a designer to adapt the vast HTML resources of the Internet for use in the television environment for entertainment, educational or informational purposes.

FIG. 1

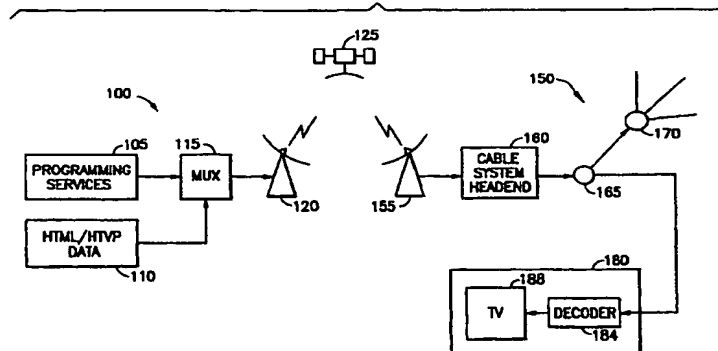

EP 0 837 599 A3



European Patent Office

EUROPEAN SEARCH REPORT

Application Number
EP 97 11 7900

DOCUMENTS CONSIDERED TO BE RELEVANT			
Category	Citation of document with indication, where appropriate, of relevant passages	Relevant to claim	CLASSIFICATION OF THE APPLICATION (Int.Cl.6)
A	WO 96 21990 A (SCIENTIFIC-ATLANTA) 18 July 1996 (1996-07-18) * page 61, line 5 - line 19 *	1,8,15	H04N5/445 //H04N5/57
A	BACH U.: "Multimedia-Terminal als Endgerät" FUNKSCHAU., vol. 68, no. 6, 1 March 1996 (1996-03-01), pages 70-75, XP000556486 FRANZIS-VERLAG K.G. MUNCHEN., DE ISSN: 0016-2841 * the whole document *	1,8,15	
A	SCHULZRINNE H.: "WORLD WIDE WEB: WHENCE, WHITHER, WHAT NEXT?" IEEE NETWORK: THE MAGAZINE OF COMPUTER COMMUNICATIONS., vol. 10, no. 2, 1 March 1996 (1996-03-01), pages 10-17, XP000570608 IEEE INC. NEW YORK., US ISSN: 0890-8044 * page 16, left-hand column, line 56 - right-hand column, line 49 *	1,8,15	
A	EP 0 737 930 A (SUN MICROSYSTEMS INC.) 16 October 1996 (1996-10-16) * column 5, line 42 - column 12, line 57 *	1,8,15	
A	"ELECTRONIC PROGRAM GUIDE VIA INTERNET" RESEARCH DISCLOSURE., no. 385, 1 May 1996 (1996-05-01), page 276 XP000599701 INDUSTRIAL OPPORTUNITIES LTD. HAVANT., GB ISSN: 0374-4353 * the whole document *	1,8,15	
The present search report has been drawn up for all claims			
Place of search THE HAGUE		Date of completion of the search 28 July 1999	Examiner Verschelden, J
CATEGORY OF CITED DOCUMENTS		T : theory or principle underlying the invention E : earlier patent document, but published on, or after the filing date D : document cited in the application L : document cited for other reasons & : member of the same patent family, corresponding document	
X : particularly relevant if taken alone Y : particularly relevant if combined with another document of the same category A : technological background O : non-written disclosure P : intermediate document			

EPO FORM 1503 03.82 (P04C01)



European Patent
Office

EUROPEAN SEARCH REPORT

Application Number
EP 97 11 7900

DOCUMENTS CONSIDERED TO BE RELEVANT			
Category	Citation of document with indication, where appropriate, of relevant passages	Relevant to claim	CLASSIFICATION OF THE APPLICATION (Int.Cl.6)
A	US 5 557 724 A (SAMPAT K. ET AL) 17 September 1996 (1996-09-17) * column 5, line 24 - column 8, line 45 *	1,8,15	
A	WO 96 17473 A (TV GUIDE ON SCREEN) 6 June 1996 (1996-06-06) * page 22, line 18 - page 37, line 22 *	1,8,15	
A	EP 0 617 556 A (SONY EUROPA GMBH) 28 September 1994 (1994-09-28) * column 22, line 40 - column 25, line 28 *	1,8,15	
			TECHNICAL FIELDS SEARCHED (Int.Cl.6)
The present search report has been drawn up for all claims			
Place of search THE HAGUE		Date of completion of the search 28 July 1999	Examiner Verschelden, J
CATEGORY OF CITED DOCUMENTS		T : theory or principle underlying the invention E : earlier patent document, but published on, or after the filing date D : document cited in the application L : document cited for other reasons & : member of the same patent family, corresponding document	
X : particularly relevant if taken alone Y : particularly relevant if combined with another document of the same category A : technological background O : non-written disclosure P : intermediate document			

EPO FORM 1503 03 82 (P04/C01)

ANNEX TO THE EUROPEAN SEARCH REPORT
ON EUROPEAN PATENT APPLICATION NO.

EP 97 11 7900

This annex lists the patent family members relating to the patent documents cited in the above-mentioned European search report. The members are as contained in the European Patent Office EDP file on
The European Patent Office is in no way liable for these particulars which are merely given for the purpose of information.

28-07-1999

Patent document cited in search report		Publication date	Patent family member(s)	Publication date
WO 9621990	A	18-07-1996	US 5774859 A	30-06-1998
			AU 4748896 A	31-07-1996
EP 737930	A	16-10-1996	CA 2173698 A	13-10-1996
			JP 9167124 A	24-06-1997
US 5557724	A	17-09-1996	NONE	
WO 9617473	A	06-06-1996	US 5629733 A	13-05-1997
			AU 700527 B	07-01-1999
			AU 4502296 A	19-06-1996
			BR 9509826 A	30-09-1997
			CA 2204765 A	06-06-1996
			EP 0806112 A	12-11-1997
			JP 10510120 T	29-09-1998
EP 617556	A	28-09-1994	AT 172345 T	15-10-1998
			DE 69321575 D	19-11-1998
			DE 69321575 T	27-05-1999
			ES 2123013 T	01-01-1999
			FI 941313 A	23-09-1994
			JP 7226983 A	22-08-1995
			US 5532753 A	02-07-1996

EPO FORM P0459

For more details about this annex : see Official Journal of the European Patent Office, No. 12/82



#16

DECLARATION

As a below named inventor, I hereby declare that:

My residence, post office address, and citizenship are as stated below next to my name.

I believe I am the original, first and sole inventor (if only one name is listed below) or an original, first and joint inventor (if plural names are listed below) of the subject matter which is claimed and for which a patent is sought on the invention entitled "SUPPORTING COMMON INTERACTIVE TELEVISION FUNCTIONALITY THROUGH PRESENTATION ENGINE SYNTAX," the specification of which:

- is attached hereto.
- was filed on April 21, 2003 as Application Serial No. 10/419,621.

I hereby state that I have reviewed and understand the contents of the above-identified specification, including the claims, as amended by any amendment referred to above.

I acknowledge the duty to disclose to the Patent and Trademark Office all information known to me to be material to patentability of the subject matter claimed in this application, as "materiality" is defined in 37 C.F.R. § 1.56.

I hereby claim foreign priority benefits under 35 U.S.C. § 119(a)-(d) or § 365(b) of any foreign application(s) for patent or inventor's certificate listed below, or under § 365(a) of any PCT international application listed below designating least one country other than the United States of America, and have identified below any foreign application for patent or inventor's certificate, or of any PCT international application, having a filing date before that of the application on which priority is claimed.

<u>Prior Foreign Application No.</u>	<u>Country</u>	<u>Filing Date (mm/dd/yy)</u>	<u>Priority Claimed</u>	<u>Cert. copy Attached</u>
_____	_____	_____	_____	_____
_____	_____	_____	_____	_____

I hereby claim the benefit under 35 U.S.C. § 119(e) of any United States provisional application(s) listed below.

<u>Provisional Application No.</u>	<u>Filing Date (mm/dd/yy)</u>
<u>60/373,883</u>	<u>04/19/02</u>
_____	_____

I hereby claim the benefit under 35 U.S.C. § 120 of any United States application(s) listed below, or under § 365(c) of any PCT international application listed below designating the United States of America, and, insofar as the subject matter of each of the claims of this application is not disclosed in the prior United States or PCT international application in the manner provided by the first paragraph of 35 U.S.C. § 112, I acknowledge the duty to disclose all information known to me to be material to the patentability of the subject matter claimed in this application, as "materiality" is defined in 37 C.F.R. § 1.56, which became available between the filing date of the prior application and the national or PCT international filing date of this application.

<u>Parent Application No.</u>	<u>Filing Date (mm/dd/yy)</u>	<u>Parent Patent No. (if applicable) or Status</u>
_____	_____	_____
_____	_____	_____

I hereby declare that all statements made herein of my own knowledge are true and that all statements made herein on information and belief are believed to be true; and further that these statements were made with the knowledge that willful false statements and the like so made are punishable by fine or imprisonment, or both, under 18 U.S.C. § 1001 and that such willful false statements may jeopardize the validity of the application or any patent issued thereon.

Inventor's Full Name: _____ Alain Delpuch _____
Inventor's Signature: _____ Date: _____
City and State (or Foreign Country) of Residence: _____ Citizenship: _____
Post Office and Residence Address: _____
(Include number, street name, city, state and zip code)

Inventor's Full Name: _____ James Whitledge _____
Inventor's Signature: James R. Whitledge Date: 6/22/03
City and State (or Foreign Country) of Residence: Naperville, IL Citizenship: USA
Post Office and Residence Address: 30W345 Bruce Ln, Naperville IL 60563
(Include number, street name, city, state and zip code)

Inventor's Full Name: _____ Jean-Rene Menand _____
Inventor's Signature: _____ Date: _____
City and State (or Foreign Country) of Residence: _____ Citizenship: _____
Post Office and Residence Address: _____
(Include number, street name, city, state and zip code)

Inventor's Full Name: _____ Emmanuel Barbier _____
Inventor's Signature: _____ Date: _____
City and State (or Foreign Country) of Residence: _____ Citizenship: _____
Post Office and Residence Address: _____
(Include number, street name, city, state and zip code)

Inventor's Full Name: _____ Kevin Hausman _____
Inventor's Signature: _____ Date: _____
City and State (or Foreign Country) of Residence: _____ Citizenship: _____
Post Office and Residence Address: _____
(Include number, street name, city, state and zip code)

Inventor's Full Name: _____ Debra Hensgen _____
Inventor's Signature: _____ *Debra Hensgen* _____ Date: *07/14/03* _____
City and State (or Foreign Country) of Residence: *Redwood City* _____ Citizenship: *USA* _____
Post Office and Residence Address: *977 Upland Rd Redwood City, CA 94062* _____
(Include number, street name, city, state and zip code)

Inventor's Full Name: _____ Dongmin Su _____
Inventor's Signature: _____ Date: _____
City and State (or Foreign Country) of Residence: _____ Citizenship: _____
Post Office and Residence Address: _____
(Include number, street name, city, state and zip code)



DECLARATION

As a below named inventor, I hereby declare that:

My residence, post office address, and citizenship are as stated below next to my name.

I believe I am the original, first and sole inventor (if only one name is listed below) or an original, first and joint inventor (if plural names are listed below) of the subject matter which is claimed and for which a patent is sought on the invention entitled "**SUPPORTING COMMON INTERACTIVE TELEVISION FUNCTIONALITY THROUGH PRESENTATION ENGINE SYNTAX**," the specification of which:

- is attached hereto.
- was filed on April 21, 2003 as Application Serial No. 10/419,621.

I hereby state that I have reviewed and understand the contents of the above-identified specification, including the claims, as amended by any amendment referred to above.

I acknowledge the duty to disclose to the Patent and Trademark Office all information known to me to be material to patentability of the subject matter claimed in this application, as "materiality" is defined in 37 C.F.R. § 1.56.

I hereby claim foreign priority benefits under 35 U.S.C. § 119(a)-(d) or § 365(b) of any foreign application(s) for patent or inventor's certificate listed below, or under § 365(a) of any PCT international application listed below designating least one country other than the United States of America, and have identified below any foreign application for patent or inventor's certificate, or of any PCT international application, having a filing date before that of the application on which priority is claimed.

<u>Prior Foreign Application No.</u>	<u>Country</u>	<u>Filing Date</u> <u>(mm/dd/yy)</u>	<u>Priority</u> <u>Claimed</u>	<u>Cert. copy</u> <u>Attached</u>
_____	_____	_____	_____	_____
_____	_____	_____	_____	_____

I hereby claim the benefit under 35 U.S.C. § 119(e) of any United States provisional application(s) listed below.

<u>Provisional Application No.</u>	<u>Filing Date</u> <u>(mm/dd/yy)</u>
<u>60/373,883</u>	<u>04/19/02</u>
_____	_____

I hereby claim the benefit under 35 U.S.C. § 120 of any United States application(s) listed below, or under § 365(c) of any PCT international application listed below designating the United States of America, and, insofar as the subject matter of each of the claims of this application is not disclosed in the prior United States or PCT international application in the manner provided by the first paragraph of 35 U.S.C. § 112, I acknowledge the duty to disclose all information known to me to be material to the patentability of the subject matter claimed in this application, as "materiality" is defined in 37 C.F.R. § 1.56, which became available between the filing date of the prior application and the national or PCT international filing date of this application.

<u>Parent Application No.</u>	<u>Filing Date</u> <u>(mm/dd/yy)</u>	<u>Parent Patent No. (if applicable) or Status</u>
_____	_____	_____
_____	_____	_____

RECEIVED

SEP 25 2003

OFFICE OF PETITIONS

I hereby declare that all statements made herein of my own knowledge are true and that all statements made herein on information and belief are believed to be true; and further that these statements were made with the knowledge that willful false statements and the like so made are punishable by fine or imprisonment, or both, under 18 U.S.C. § 1001 and that such willful false statements may jeopardize the validity of the application or any patent issued thereon.

Inventor's Full Name: _____ Alain Delpuch _____

Inventor's Signature: _____ Date: _____

City and State (or Foreign Country) of Residence: _____ Citizenship: _____

Post Office and Residence Address: _____
(Include number, street name, city, state and zip code)

Inventor's Full Name: _____ James Whitley _____

Inventor's Signature: _____ Date: _____

City and State (or Foreign Country) of Residence: _____ Citizenship: _____

Post Office and Residence Address: _____
(Include number, street name, city, state and zip code)

Inventor's Full Name: _____ Jean-Rene Menard _____

Inventor's Signature: Jean Rene Menard Date: 7/15/03

City and State (or Foreign Country) of Residence: LOS ALTOS, CA Citizenship: FRANCE

Post Office and Residence Address: 1535 SIESTA DRIVE, LOS ALTOS, CA 94024
(Include number, street name, city, state and zip code)

Inventor's Full Name: _____ Emmanuel Barbier _____

Inventor's Signature: _____ Date: _____

City and State (or Foreign Country) of Residence: _____ Citizenship: _____

Post Office and Residence Address: _____
(Include number, street name, city, state and zip code)

Inventor's Full Name: _____ Kevin Hausman _____

Inventor's Signature: _____ Date: _____

City and State (or Foreign Country) of Residence: _____ Citizenship: _____

Post Office and Residence Address: _____
(Include number, street name, city, state and zip code)

Inventor's Full Name: _____ Debra Hensgen _____

Inventor's Signature: _____ Date: _____

City and State (or Foreign Country) of Residence: _____ Citizenship: _____

Post Office and Residence Address: _____
(Include number, street name, city, state and zip code)

Inventor's Full Name: _____ Dongmin Su _____

Inventor's Signature: _____ Date: _____

City and State (or Foreign Country) of Residence: _____ Citizenship: _____

Post Office and Residence Address: _____
(Include number, street name, city, state and zip code)



DECLARATION

As a below named inventor, I hereby declare that:

My residence, post office address, and citizenship are as stated below next to my name.

I believe I am the original, first and sole inventor (if only one name is listed below) or an original, first and joint inventor (if plural names are listed below) of the subject matter which is claimed and for which a patent is sought on the invention entitled "SUPPORTING COMMON INTERACTIVE TELEVISION FUNCTIONALITY THROUGH PRESENTATION ENGINE SYNTAX," the specification of which:

- is attached hereto.
- was filed on April 21, 2003 as Application Serial No. 10/419,621.

I hereby state that I have reviewed and understand the contents of the above-identified specification, including the claims, as amended by any amendment referred to above.

I acknowledge the duty to disclose to the Patent and Trademark Office all information known to me to be material to patentability of the subject matter claimed in this application, as "materiality" is defined in 37 C.F.R. § 1.56.

I hereby claim foreign priority benefits under 35 U.S.C. § 119(a)-(d) or § 365(b) of any foreign application(s) for patent or inventor's certificate listed below, or under § 365(a) of any PCT international application listed below designating least one country other than the United States of America, and have identified below any foreign application for patent or inventor's certificate, or of any PCT international application, having a filing date before that of the application on which priority is claimed.

<u>Prior Foreign Application No.</u>	<u>Country</u>	<u>Filing Date</u> <u>(mm/dd/yy)</u>	<u>Priority</u> <u>Claimed</u>	<u>Cert. copy</u> <u>Attached</u>
_____	_____	_____	_____	_____
_____	_____	_____	_____	_____

I hereby claim the benefit under 35 U.S.C. § 119(e) of any United States provisional application(s) listed below.

<u>Provisional Application No.</u>	<u>Filing Date</u> <u>(mm/dd/yy)</u>
<u>60/373,883</u>	<u>04/19/02</u>
_____	_____

I hereby claim the benefit under 35 U.S.C. § 120 of any United States application(s) listed below, or under § 365(c) of any PCT international application listed below designating the United States of America, and, insofar as the subject matter of each of the claims of this application is not disclosed in the prior United States or PCT international application in the manner provided by the first paragraph of 35 U.S.C. § 112, I acknowledge the duty to disclose all information known to me to be material to the patentability of the subject matter claimed in this application, as "materiality" is defined in 37 C.F.R. § 1.56, which became available between the filing date of the prior application and the national or PCT international filing date of this application.

<u>Parent Application No.</u>	<u>Filing Date</u> <u>(mm/dd/yy)</u>	<u>Parent Patent No. (if applicable) or Status</u>
_____	_____	_____
_____	_____	_____

RECEIVED

SEP 25 2003

OFFICE OF PETITIONS

I hereby declare that all statements made herein of my own knowledge are true and that all statements made herein on information and belief are believed to be true; and further that these statements were made with the knowledge that willful false statements and the like so made are punishable by fine or imprisonment, or both, under 18 U.S.C. § 1001 and that such willful false statements may jeopardize the validity of the application or any patent issued thereon.

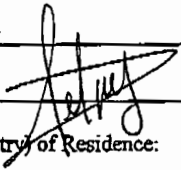
Inventor's Full Name: Alain Delpuch
Inventor's Signature:  Date: June 20, 2003
City and State (or Foreign Country) of Residence: FRANCE -Citizenship: FRANCE
Post Office and Residence Address: 34 PARC DES ESSANTS 78690 LESESSANT LE ROI
(Include number, street name, city, state and zip code)

Inventor's Full Name: James Whitledge
Inventor's Signature: _____ Date: _____
City and State (or Foreign Country) of Residence: _____ Citizenship: _____
Post Office and Residence Address: _____
(Include number, street name, city, state and zip code)

Inventor's Full Name: Jean-Rene Menand
Inventor's Signature: _____ Date: _____
City and State (or Foreign Country) of Residence: _____ Citizenship: _____
Post Office and Residence Address: _____
(Include number, street name, city, state and zip code)

Inventor's Full Name: Emmanuel Barbier
Inventor's Signature:  Date: June 20, 2003
City and State (or Foreign Country) of Residence: FRANCE -Citizenship: FRENCH
Post Office and Residence Address: 6 BIS, RUE DES ECOLES 75005 PARIS
(Include number, street name, city, state and zip code)

Inventor's Full Name: Kevin Hausman

Inventor's Signature:  Date: 7/6/05

City and State (or Foreign Country) of Residence: Naperville IL Citizenship: US

Post Office and Residence Address: 1105 Manchester Ct, Naperville, IL 60563
(Include number, street name, city, state and zip code)

Inventor's Full Name: Debra Hensgen

Inventor's Signature: _____ Date: _____

City and State (or Foreign Country) of Residence: _____ Citizenship: _____

Post Office and Residence Address: _____
(Include number, street name, city, state and zip code)

Inventor's Full Name: Dongmin Su

Inventor's Signature: _____ Date: _____

City and State (or Foreign Country) of Residence: _____ Citizenship: _____

Post Office and Residence Address: _____
(Include number, street name, city, state and zip code)

45



POWER OF ATTORNEY

OpenTV, Inc., owner of the application for United States Letters Patent on the invention entitled "SUPPORTING COMMON INTERACTIVE TELEVISION FUNCTIONALITY THROUGH PRESENTATION ENGINE SYNTAX," the specification of which:

- is attached hereto.
- was filed on April 21, 2003 as Application Serial No. 10/419,621.

does hereby revoke any previous Powers of Attorney and appoint

Mark K. Brightwell	Reg. No. 47,446
Kay A. Colapret	Reg. No. 52,759
Stephen J. Curran	Reg. No. 50,664
Mark R. DeLuca	Reg. No. 44,649
Heather L. Flanagan	Reg. No. 54,101
Russell Henrichs	Reg. No. 50,354
Erik A. Heter	Reg. No. 50,652
Jeffrey C. Hood	Reg. No. 35,198
B. Noël Kivlin	Reg. No. 33,929
Robert C. Kowert	Reg. No. 39,255
Lawrence J. Merkel	Reg. No. 41,191
Eric B. Meyertons	Reg. No. 34,876
Neal E. Persky	Reg. No. 53,452
Liza Philip	Reg. No. 51,352
David W. Quimby	Reg. No. 39,338
Rory D. Rankin	Reg. No. 47,884
Gareth Sampson	Reg. No. 52,191
Russell C. Scott	Reg. No. 43,103
Chris Thompson	Reg. No. 43,188
Mark S. Williams	Reg. No. 50,658

each of said attorneys or agents being a member or an associate of the firm of Meyertons, Hood, Kivlin, Kowert & Goetzel, P.C., as attorney or agent for so long as they remain with such company or firm, with full power of substitution and revocation, to prosecute the application, to make alterations and amendments therein, to transact all business in the Patent and Trademark Office in connection therewith, and to receive the Letters Patent.

Please direct all communications to:

Rory D. Rankin
Meyertons, Hood, Kivlin, Kowert & Goetzel, P.C.
P.O. Box 398
Austin, Texas 78767-0398
Phone: (512) 853-8800

RECEIVED

SEP 25 2003

OFFICE OF PETITIONS

I, the undersigned, declare that I am the (an) owner of the above-identified application or, if the owner is a corporation, partnership or other association, I am authorized to make this appointment on behalf of the owner thereof.

I hereby declare that all statements made herein of my own knowledge are true and that all statements made herein on information and belief are believed to be true; and further that these statements were made with the knowledge that willful false statements and the like so made are punishable by fine or imprisonment, or both, under 18 U.S.C. § 1001 and that such willful false statements may jeopardize the validity of the application or any patent issued thereon.

Full Name of Declarant: OpenTV, Inc.
(If owner is corporation, partnership or association)

Title of Declarant: Thomas L. Ewing
Vice President and Chief Intellectual Property Officer

Address of Declarant: 275 Sacramento Street, San Francisco, CA 94111
(Include number, street name, city, state and zip code)

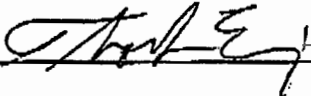
Signature of Owner:  Date: Sept. 18, 2003



#3

IN THE UNITED STATES PATENT AND TRADEMARK OFFICE

In re Application of:
Delpuch et al.

Serial No. 10/419,621

Filed: April 21, 2003

For: Supporting Common Interactive
Television Functionality Through
Presentation Engine Syntax

§
§
§
§
§
§
§
§
§
§
§
§
§

Group Art Unit: 2611
Examiner: Unknown

Atty. Dkt. No. 5266-06201

I hereby certify that this correspondence is being deposited with the U.S. Postal Service as First Class Mail in an envelope addressed to: Commissioner for Patents, P.O. Box 1450, Alexandria, VA 22313-1450, on the date indicated below:

Rory D. Rankin
Registered Representative

Sep. 18 2003
Date

Signature

PETITION UNDER 37 CFR § 1.47(a)

Commissioner for Patents
P.O. Box 1450
Alexandria, VA 22313-1450

The United States Patent and Trademark Office is respectfully requested to accept the above-referenced patent application pursuant to 37 CFR § 1.47(a). Executed declarations are submitted herewith for all of the inventors except Dongmin Su. As shown in the Statement of Facts submitted herewith, delivery of a copy of the above-referenced patent application and declaration has been made to Mr. Su's current address on multiple occasions. However, Mr. Su has not signed and returned the declaration. The remaining inventors submit the above-referenced patent application on behalf of themselves and on behalf of Dongmin Su.

The non-joining inventor's last known address is:

Dongmin Su
2038 Finley Place
Santa Clara, CA 95050
U.S.A.

RECEIVED

SEP 25 2003

OFFICE OF PETITIONS

A fee authorization form for the fee set forth in 37 CFR § 1.17(h) is enclosed herewith.

Respectfully submitted,

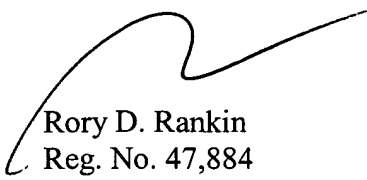

Rory D. Rankin
Reg. No. 47,884
Attorney for Applicants

Meyertons, Hood, Kivlin, Kowert & Goetzl, P.C.
P.O. Box 398
Austin, Texas 78767-0398
Ph: (512) 853-8850

Date: Sep. 18, 2003

5. On August 18, 2003, I delivered a copy of the above-referenced patent application and a Declaration form to Mr. Dongmin Su's present address. Delivery of the application papers was accepted on August 19, 2003, as evidenced by the attached Federal Express delivery receipt and corresponding cover letter, which accompanied the application papers.

6. On August 21, 2003, I placed a telephone call to Mr. Su at his home phone number 408-246-7572. A woman, who identified herself as Mr. Su's wife, answered the phone and indicated Mr. Su was unavailable. However, she did indicate that they had received the application papers which we delivered to Mr. Su and that Mr. Su was aware of the papers. I then asked her to have Mr. Su contact me with any questions or concerns he may have with regard to signing the documents he received. Mr. Su did not return the signed papers and did not contact me.

7. Mr. Su has refused to sign an Inventor's Declaration and Assignment papers in the past. On June 23, 2003, Christine M. Manchester who is currently employed with OpenTV, Inc, conveyed application papers including Declaration and Assignment forms to Mr. Su's current address. Delivery of the application papers was accepted on June 24, 2003, as evidenced by the attached Federal Express delivery receipt and corresponding cover letter, which accompanied the application papers. Mr. Su did not sign and return the delivered forms. Subsequently, on August 5, 2003, Christine M. Manchester again conveyed application papers including Declaration and Assignment forms to Mr. Su's current address. Delivery of the application papers was accepted on August 6, 2003, as evidenced by the attached Federal Express delivery receipt and corresponding cover letter, which accompanied the application papers. Mr. Su did not sign and return the delivered forms.

8. I hereby declare that all statements made herein of my own knowledge are true and that all statements made herein on information and belief are believed to be true; and further that these statements were made with the knowledge that willful false statements and the like so made are punishable by fine or imprisonment, or both, under 18 U.S.C. § 1001 and that such willful false statements may jeopardize the validity of the application or any patent issued thereon.

Rory D. Rankin

Date: Sep. 18, 2003

[United States Home](#)

[Information Center](#) | [Customer Supp](#)



Search

Package / Envelope Services

Freight Services

Same Day Services

Ship

Track

Rates

Pickup

Locations

Transit Time

International

Track Shipments Detailed Results

[Printable Version](#) [Quick Help](#)

Tracking number 792273727007
Signed for by T.LU
Ship date Jun 23, 2003
Delivery date/time Jun 24, 2003 10:49 am

Reference number 130/CHRISTINE
MANCHESTER
Delivery location SANTA CLARA CA
Service type Standard Envelope

- You can also track
- [By Alternat](#)
 - [By Email](#)
 - [TCN \(Gov't](#)

- Track other FedEx
- [FedEx Cus shipments](#)
 - [FedEx Trac shipments](#)
 - [Internation](#)

Date/time	Status	Location	Comments
Jun 24, 2003 10:49 am	Delivered	SANTA CLARA CA	

[Signature proof](#) [Track more shipments](#)

Email your detailed tracking results (optional)

[Wrong Address?](#)
Reduce future mista
[FedEx Address Che](#)

Enter your email, submit up to three email addresses (separated by commas), add your message (optional), and click **Send email**.

From
To

Add a message to this email.

[Send email](#)

[Global Home](#) | [Service Info](#) | [About FedEx](#) | [Investor Relations](#) | [Careers](#) | [fedex.com Terms of Use](#) | [Privacy Policy](#)

This site is protected by copyright and trademark laws under U.S. and International law. All rights reserved. © 1995-2003 FedEx



CHRISTINE M. MANCHESTER
Direct Dial: 415-962-5295
Direct Fax: 415-962-5364
cmanchester@opentv.com

June 23, 2003

VIA FEDERAL EXPRESS

Dongmin "Danny" Su
2038 Finley Place
Santa Clara, CA 95050

**Re: United States Patent Application No. 10/419,621 entitled: "SUPPORTING
COMMON INTERACTIVE TELEVISION FUNCTIONALITY THROUGH
PRESENTATION ENGINE SYNTAX"**

Inventors: Alain Delpuch, et al.

Our Ref.: OPTV-187/ORG/US

Dear Danny:

We have received the Declaration and Assignment documents for your signature from our outside counsel in the above-referenced matter. Please sign and date the documents where indicated and return them to me as soon as possible, but no later than July 11, 2003, so that they can be filed with the United States Patent and Trademark Office.

Should you have any questions, please do not hesitate to contact me.

Very truly yours,

A handwritten signature in black ink, appearing to read "Christine M. Manchester".

Christine M. Manchester
Senior Intellectual Property Specialist

Enclosures

[United States Home](#)

[Information Center](#) | [Customer Support](#)



Package / Envelope Services		Freight Services	Same Day Services	
Ship	Track	Rates	Pickup	Locations
			Transit Time	International

Track Shipments
Detailed Results

[Printable Version](#) [Quick Help](#)

Tracking number	792302389081	Reference number	130/CHRISTINE MANCHESTER
Signed for by	T.SU	Delivered to	Recipient
Ship date	Aug 5, 2003	Delivery location	SANTA CLARA CA
Delivery date/time	Aug 6, 2003 11:36 am	Service type	Standard Envelope

You can also track

- [By Alternat](#)
- [By Email](#)
- [TCN \(Gov't](#)

Track other FedEx

- [FedEx Cus shipments](#)
- [FedEx Trac shipments](#)
- [Internation](#)

Date/time	Status	Location	Comments
Aug 6, 2003 11:36 am	Delivered	SANTA CLARA CA	
8:18 am	On FedEx vehicle for delivery	SANTA CLARA CA	
7:13 am	Arrived at FedEx Destination Location	SANTA CLARA CA	
5:46 am	Left FedEx Sort Facility	OAKLAND CA	
Aug 5, 2003 10:43 pm	Arrived at Sort Facility	OAKLAND CA	
8:00 pm	Left FedEx Origin Location	SAN FRANCISCO CA	
6:47 pm	Left FedEx Origin Location	SAN FRANCISCO CA	
3:32 pm	Picked up by FedEx	SAN FRANCISCO CA	

[Wrong Address?](#)
[Reduce future mista](#)
[FedEx Address Che](#)

Email your detailed tracking results (optional)

Enter your email, submit up to three email addresses (separated by commas), add your message (optional), and click **Send email**.

From

To

Add a message to this email.

[Global Home](#) | [Service Info](#) | [About FedEx](#) | [Investor Relations](#) | [Careers](#) | [fedex.com Terms of Use](#) | [Privacy Policy](#)

This site is protected by copyright and trademark laws under U.S. and International law. All rights reserved. © 1995-2003 FedEx



CHRISTINE M. MANCHESTER
Direct Dial: 415-962-5295
Direct Fax: 415-962-5364
cmanchester@opentv.com

August 5, 2003

VIA FEDERAL EXPRESS

Dongmin "Danny" Su
2038 Finley Place
Santa Clara, CA 95050

**Re: United States Patent Application No. 10/419,621 entitled: "SUPPORTING
COMMON INTERACTIVE TELEVISION FUNCTIONALITY THROUGH
PRESENTATION ENGINE SYNTAX"**

Inventors: Alain Delpuch, et al.
Our Ref.: OPTV-187/ORG/US

Dear Danny:

Further to my letter of June 23, 2003, forwarding the Declaration and Assignment documents for your signature in the above-referenced matter, we are still awaiting the signed documents from you. I am including a copy of the original letter with enclosures. Please sign and date the documents where indicated and return them to me as soon as possible. We have a deadline with the United States Patent and Trademark Office of August 18, 2003.

Should you have any questions, please do not hesitate to contact me.

Very truly yours,

A handwritten signature in cursive script, appearing to read "Christine M. Manchester".

Christine M. Manchester
Senior Intellectual Property Specialist

Enclosures

[United States Home](#)

[Information Center](#) | [Customer:](#)



Search

Package / Envelope Services | **Freight Services** | **Same Day Services**

Ship | **Track** | **Rates** | **Pickup** | **Locations** | **Transit Time** | **International**

Track Shipments
Detailed Results

[Printable Version](#) [Quick Help](#)

Tracking number	791473743930	Reference number	5266-06201
Signed for by	T.LU	Delivered to	Recipient
Ship date	Aug 18, 2003	Delivery location	SANTA CLARA CA
Delivery date/time	Aug 19, 2003 10:41 am	Service type	Standard Envelope

You can also track:

- [By Alternate R](#)
- [By Email](#)
- [TCN \(Gov't Sh](#)

Track other FedEx servi

- [FedEx Custom shipments](#)
- [FedEx Trade shipments](#)
- [International A](#)

Date/time	Status	Location	Comments
Aug 19, 2003	10:41 am Delivered	SANTA CLARA CA	
	8:32 am On FedEx vehicle for delivery	SANTA CLARA CA	
	8:18 am Arrived at FedEx Ramp	SAN JOSE CA	
	8:16 am Left FedEx Ramp	SAN JOSE CA	
	7:51 am Arrived at FedEx Destination Location	SANTA CLARA CA	
	5:00 am Left FedEx Sort Facility	MEMPHIS TN	
	1:31 am Left FedEx Sort Facility	MEMPHIS TN	
	12:31 am Arrived at Sort Facility	MEMPHIS TN	
Aug 18, 2003	11:06 pm Left FedEx Ramp	AUSTIN TX	
	10:15 pm Arrived at FedEx Ramp	AUSTIN TX	
	9:47 pm Left FedEx Origin Location	AUSTIN TX	
	8:12 pm Picked up by FedEx	AUSTIN TX	

[Wrong Address?](#)
Reduce future mistakes b:
[Address Checker.](#)

[Signature proof](#) | [Track more shipments](#)

Email your detailed tracking results (optional)

Enter your email, submit up to three email addresses (separated by commas), add your message (optional), and click **Send email**.

From

To

Add a message to this email.

Send email



MEYERTONS
HOOD
KIVLIN
KOWERT
& GOETZEL
A PROFESSIONAL CORPORATION

700 LAVACA, SUITE 800
AUSTIN, TEXAS 78701-3102
TELEPHONE (512) 853-8800
FACSIMILE (512) 853-8801
www.intprop.com

PATENTS, TRADEMARKS, COPYRIGHTS & UNFAIR COMPETITION

RORY D. RANKIN
(512) 853-8866
rrankin@intprop.com

FILE: 5266-06201
OPTV-187/ORG/US

August 18, 2003

Via Federal Express

Dongmin Su
2038 Finley Place
Santa Clara, CA 95050

RE: U.S. Patent Application Serial No.: 10/419,621
Entitled : **“Supporting Common Interactive Television Functionality Through
Presentation Engine Syntax”**;
Inventor: *Delpuch, et al.*;
(OpenTV Ref. No.: OPTV-187/ORG/US; Our Ref. No.: 5266-06201)

Dear Mr. Su:

Please find enclosed the above-referenced patent application, which was filed with the U.S. Patent and Trademark Office on April 21, 2003. Also enclosed are a Declaration and an Assignment form. Please complete all relevant information, sign and date these forms at the spaces provided, and return the signed forms including the enclosed application to me for filing with the U.S. Patent and Trademark Office.

We have been informed that you are no longer employed by OpenTV, Inc. Consequently, I expect that you may have some questions regarding this application and the enclosed documents. Please give me a call as I would be happy to discuss this with you and to answer any questions you may have. You can reach me at (512) 853-8866.

Very truly yours,

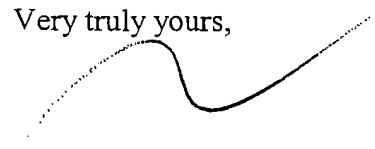
Rory D. Rankin

RDR/psa
Enclosure
cc: Christine Manchester

RECEIVED

SEP 25 2003

OFFICE OF PETITIONS



UNITED STATES
PATENT AND
TRADEMARK OFFICE

COPY

5266-06200 ✓

FEBRUARY 11, 2003

CONLEY, ROSE & TAYON, P.C.
RORY D. RANKIN
P.O. BOX 398
AUSTIN, TEXAS 78767-0398

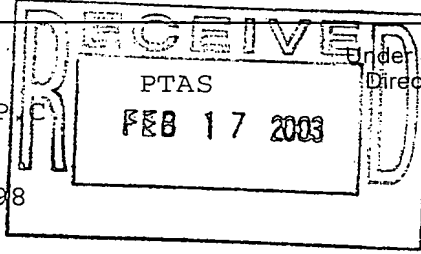

Under Secretary of Commerce For Intellectual Property and
Director of the United States Patent and Trademark Office
Washington, DC 20231
www.uspto.gov



102264099A

UNITED STATES PATENT AND TRADEMARK OFFICE
NOTICE OF RECORDATION OF ASSIGNMENT DOCUMENT

THE ENCLOSED DOCUMENT HAS BEEN RECORDED BY THE ASSIGNMENT DIVISION OF THE U.S. PATENT AND TRADEMARK OFFICE. A COMPLETE MICROFILM COPY IS AVAILABLE AT THE ASSIGNMENT SEARCH ROOM ON THE REEL AND FRAME NUMBER REFERENCED BELOW.

PLEASE REVIEW ALL INFORMATION CONTAINED ON THIS NOTICE. THE INFORMATION CONTAINED ON THIS RECORDATION NOTICE REFLECTS THE DATA PRESENT IN THE PATENT AND TRADEMARK ASSIGNMENT SYSTEM. IF YOU SHOULD FIND ANY ERRORS OR HAVE QUESTIONS CONCERNING THIS NOTICE, YOU MAY CONTACT THE EMPLOYEE WHOSE NAME APPEARS ON THIS NOTICE AT 703-308-9723. PLEASE SEND REQUEST FOR CORRECTION TO: U.S. PATENT AND TRADEMARK OFFICE, ASSIGNMENT DIVISION, BOX ASSIGNMENTS, CG-4, 1213 JEFFERSON DAVIS HWY, SUITE 320, WASHINGTON, D.C. 20231.

RECORDATION DATE: 10/21/2002

REEL/FRAME: 013418/0852
NUMBER OF PAGES: 11

BRIEF: ASSIGNMENT OF ASSIGNOR'S INTEREST (SEE DOCUMENT FOR DETAILS).

ASSIGNOR:

DELPUCH, ALAIN

DOC DATE: 08/27/2002

ASSIGNOR:

WHITLEDGE, JAMES

DOC DATE: 08/26/2002

ASSIGNOR:

MENAND, JEAN-RENE

DOC DATE: 10/04/2002

ASSIGNOR:

BARBIER, EMMANUEL

DOC DATE: 08/27/2002

ASSIGNOR:

HAUSMAN, KEVIN

DOC DATE: 08/28/2002

ASSIGNOR:

HENSGEN, DEBRA

DOC DATE: 10/04/2002

ASSIGNOR:

SU, DONGMIN

DOC DATE: 08/26/2002

ASSIGNEE:

OPENTV, INC.
401 EAST MIDDLEFIELD ROAD
MOUNTAIN VIEW, CALIFORNIA
94043-
4005

SERIAL NUMBER: 60373883
PATENT NUMBER:

FILING DATE: 04/19/2002
ISSUE DATE:

ALLYSON PURNELL, EXAMINER
ASSIGNMENT DIVISION
OFFICE OF PUBLIC RECORDS

REC'D

10-29-2002

Patent and Trademark Office



102264099

To the Honorable Commissioner of Patents and Trademarks. Please refer to

1. Name of conveying party(ies):

Alain Delpuch
James Whitledge
Jean-Rene Menand
Emmanuel Barbier
Kevin Hausman
Debra Hensgen
Dongmin Su

10-21-02

2. Name and address of receiving party(ies):

Name: OpenTV, Inc.

Internal Address: _____

Street Address: 401 East Middlefield Road

City Mountain View State CA ZIP 94043-4005

Additional name(s) & address(es) attached? Yes No

Additional name(s) of conveying party(ies) attached? Yes No

3. Nature of Conveyance:

- Assignment
- Merger
- Security Agreement
- Change of Name
- Other _____

Execution Date: October 4, 2002

OFFICE OF PUBLIC RECORDS
2002 OCT 21 PM 12:02
FINANCE SECTION

4. Application number(s) or patent number(s):

If this document is being filed together with a new application, the execution date of this application is:

A. Patent Application No.(s)
60/373,883 filed 04/19/2002

B. Patent No.(s)

Additional numbers attached? Yes No

5. Name and address of party to whom correspondence concerning document should be mailed:

Name: Rory D. Rankin

Internal Address: Conley, Rose & Tayon, P.C.

Street Address: P.O. Box 398

City Austin State TX ZIP 78767-0398

6. Total number of applications and patents involved: 1

7. Total fee (37 CFR 3.41):\$ 40.00

- Fee Authorization Form Enclosed
- Authorized to be charged to deposit account

8. Deposit account number: 501505/5266-06200/RDR
(Attach a duplicate copy of this page if paying by deposit account)

DO NOT USE THIS SPACE

9. Statement and Signature.

To the best of my knowledge and belief, the foregoing information is true and correct and any attached copy is a true copy of the original document.

Rory D. Rankin
Name of Person Signing
Reg. No. 47,884

Signature

Oct. 15, 2002
Date

Total number of pages: 11

OMB No. 0651-011 (exp.4/94)

28/2002 LMUeller 0000072 501505 60373883

FC:8021 40.00 CH



#4

IN THE UNITED STATES PATENT AND TRADEMARK OFFICE

In re Application of:

Delpuch, et al.

Serial No. 10/419,621

Filed: April 21, 2003

For: SUPPORTING COMMON
INTERACTIVE TELEVISION
FUNCTIONALITY THROUGH
PRESENTATION ENGINE
SYNTAX

§
§
§
§
§
§
§
§
§
§
§
§
§

Group Art Unit: 2611

Examiner: Unknown

Atty. Dkt. No.: 5266-06201

I hereby certify that this correspondence is being deposited with the U.S. Postal Service as First Class Mail in an envelope addressed to: Commissioner for Patents, P.O. Box 1450, Alexandria, VA 22313-1450, on the date indicated below:

Rory D. Rankin
 Name of Registered Agent

Sep. 18 2003
 Date

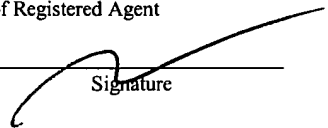
 Signature

**PETITION UNDER 37 C.F.R. §1.136
FOR EXTENSION OF TIME**

Commissioner for Patents
P.O. Box 1450
Alexandria, VA 22313-1450

Sir:

Applicant respectfully petitions the Commissioner for a one-month extension of time under 37 C.F.R. §1.136 within which to respond to the Notice to File Missing Parts of a Nonprovisional Application mailed June 18, 2003, such extension allowing the undersigned until September 18, 2003, to respond.

A fee authorization is enclosed to cover this extension fee. However, if the fee authorization is missing or insufficient, the Commissioner is authorized to charge any additional fees which may be required, or credit any overpayment, to Meyertons, Hood, Kivlin, Kowert & Goetzel, P.C. Deposit Account No. 50-1505\5266-06201\RD.R.

Respectfully submitted

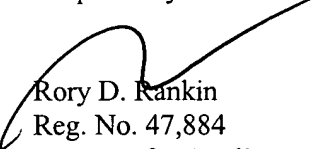
Rory D. Rankin
Reg. No. 47,884
Attorney for Applicants

Meyertons, Hood, Kivlin, Kowert & Goetzel, P.C.
P.O. Box 398

Austin, Texas 78767-0398

Ph: (512) 853-8800

Date: Sep. 18, 2003

09/24/2003 SLUANG1 00000020 10419621

02 FC:1251

110.00 DA

RECEIVED

SEP 25 2003

OFFICE OF PETITIONS



UNITED STATES PATENT AND TRADEMARK OFFICE

UNITED STATES DEPARTMENT OF COMMERCE
 United States Patent and Trademark Office
 Address: COMMISSIONER OF PATENTS AND TRADEMARKS
 P.O. Box 1450
 Alexandria, Virginia 22313-1450
 www.uspto.gov

APPLICATION NUMBER	FILING/RECEIPT DATE	FIRST NAMED APPLICANT	ATTORNEY DOCKET NUMBER
10/419,621	04/21/2003	Alain Delpuch	5266-06201

35690
 MEYERTONS, HOOD, KIVLIN, KOWERT & GOETZEL, P.C.
 P.O. BOX 398
 AUSTIN, TX 78767-0398

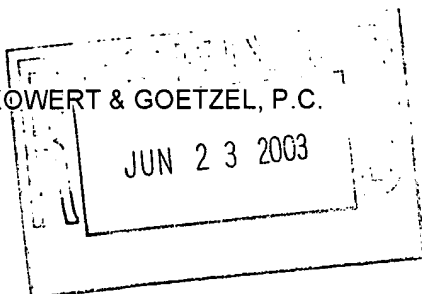

CONFIRMATION NO. 2305
 FORMALITIES LETTER



OC00000010286898

Date Mailed: 06/18/2003



NOTICE TO FILE MISSING PARTS OF NONPROVISIONAL APPLICATION

FILED UNDER 37 CFR 1.53(b)

Filing Date Granted

Items Required To Avoid Abandonment:

An application number and filing date have been accorded to this application. The item(s) indicated below, however, are missing. Applicant is given **TWO MONTHS** from the date of this Notice within which to file all required items and pay any fees required below to avoid abandonment. Extensions of time may be obtained by filing a petition accompanied by the extension fee under the provisions of 37 CFR 1.136(a).

- The oath or declaration is missing.
A properly signed oath or declaration in compliance with 37 CFR 1.63, identifying the application by the above Application Number and Filing Date, is required.
- To avoid abandonment, a late filing fee or oath or declaration surcharge as set forth in 37 CFR 1.16(e) of \$130 for a non-small entity, must be submitted with the missing items identified in this letter.

SUMMARY OF FEES DUE:

Total additional fee(s) required for this application is **\$130** for a Large Entity

- **\$130** Late oath or declaration Surcharge.

09/24/2003 SLUANG1 00000020 10419621

03 FC:1051 130.00 DA

*A copy of this notice **MUST** be returned with the reply.*

UB

Customer Service Center
 Initial Patent Examination Division (703) 308-1202

PART 2 - COPY TO BE RETURNED WITH RESPONSE

09/24/2003 SLUANG1 00000020 501505 10419621

02 FC:1251 110.00 DA

RECEIVED

SEP 25 2003

OFFICE OF PETITIONS

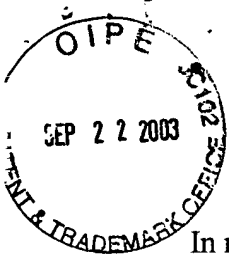

DACIMP
#

IN THE UNITED STATES PATENT AND TRADEMARK OFFICE

In re Application of:

Delpuch, *et al.*

Serial No. 10/419,621

Filed: April 21, 2003

For: SUPPORTING COMMON
INTERACTIVE TELEVISION
FUNCTIONALITY THROUGH
PRESENTATION ENGINE
SYNTAX

§
§
§
§
§
§
§
§
§
§
§
§
§
§
§

Group Art Unit: 2611

Examiner: Unknown

Atty. Dkt. No.: 5266-06201

I hereby certify that this correspondence is being deposited with the U.S. Postal Service as First Class Mail in an envelope addressed to: Commissioner for Patents, P.O. Box 1450, Alexandria, VA 22313-1450, on the date indicated below:

Rory D. Rankin
Name of Registered Agent

Date

Signature

RESPONSE TO NOTICE TO FILE MISSING PARTS OF APPLICATION

Commissioner for Patents
P.O. Box 1450
Alexandria, VA 22313-1450

Dear Sir:

Enclosed herewith is the following with regard to the above-identified application:

- (a) An Assignment of the invention executed by the inventor(s).
- (b) A Declaration executed by the inventor(s)
- (c) An executed Power of Attorney.
- (d) A Petition Under 37 CFR § 1.47 (a).
- (e) A Statement of Facts in Support of Petition Under 37 CFR § 1.47(a) with 3 attached Federal Express delivery receipts and corresponding cover letters for documents sent.

RECEIVED

SEP 25 2003

OFFICE OF PETITIONS

- (f) A Request for a One-Month Extension of Time.
- (g) A Fee Authorization form in the amount of \$410.00 to cover the filing fee for the Petition Fee (\$130.00), One-Month Extension (\$110.00), an Assignment Fee (\$40.00), and surcharge for late filing of oath or declaration for large entity (\$130.00).
- (h) A copy of Notice to File Missing Parts of Application Filing Date Granted.
- (i) A return postcard to acknowledge receipt of these materials. Please stamp and return this postcard to the undersigned.

If any fees are inadvertently omitted or if any additional fees are required or have been overpaid, please appropriately charge or credit those fees to Meyertons, Hood, Kivlin, Kowert & Goetzel, P.C. Deposit Account Number 501505/5266-06201/RDR.

Respectfully submitted,

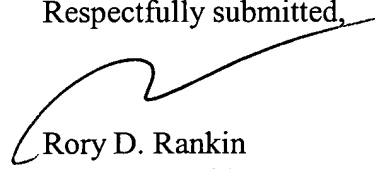

Rory D. Rankin
Reg. No. 47,884
Attorney for Applicants

Meyertons, Hood, Kivlin, Kowert & Goetzel, P.C.
P.O. Box 398
Austin, Texas 78767-0398
Ph: (512) 853-8800
Date: Sep. 18, 2003

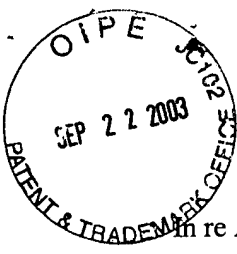

IN THE UNITED STATES PATENT AND TRADEMARK OFFICE

In re Application of:

Delpuch, *et al.*

Serial No. 10/419,621

Filed: April 21, 2003

For: SUPPORTING COMMON INTERACTIVE TELEVISION FUNCTIONALITY THROUGH PRESENTATION ENGINE SYNTAX

§
§
§
§
§
§
§
§
§
§
§
§
§
§
§

Group Art Unit: 2611

Examiner: Unknown

Atty. Dkt. No.: 5266-06201

I hereby certify that this correspondence is being deposited with the U.S. Postal Service as First Class Mail in an envelope addressed to: Commissioner for Patents, P.O. Box 1450, Alexandria, VA 22313-1450, on the date indicated below:	
<u>Rory D. Rankin</u> Name of Registered Agent	
<u>Sep. 18, 2003</u> Date	 Signature

FEE AUTHORIZATION

Commissioner for Patents
P.O. Box 1450
Alexandria, VA 22313-1450

The Commissioner is hereby authorized to charge the following fee to Meyertons, Hood, Kivlin, Kowert & Goetzel, P.C., Deposit Account Number 50-1505/5266-06201/RDR:

Petition Fee:	<u>\$ 130.00</u>
One Month Extension of Time:	<u>\$ 110.00</u>
Assignment:	<u>\$ 40.00</u>
Surcharge – Late Oath or Declaration:	<u>\$ 130.00</u>
TOTAL	<u>\$ 410.00</u>

Attorney Docket No.: 5266-06201

The Commissioner is also authorized to charge any extension fee or other fees, which may be necessary to the same account number.

Respectfully submitted,

Rory D. Rankin
Reg. No. 47,884
Attorney for Applicants

Meyertons, Hood, Kivlin, Kowert & Goetzel, P.C.
P.O. Box 398
Austin, Texas 78767-0398
Ph: (512) 853-8800
Date: Sep. 18, 2003

RECEIVED
SEP 25 2003
OFFICE OF PETITIONS



Paper No. 7

MEYERTONS, HOOD, KIVLIN, KOWERT & GOETZEL, P.C.
P.O. BOX 398
AUSTIN, TX 78767-0398

COPY MAILED

NOV 03 2003

In re Application of	:	
Delpuch et al.	:	OFFICE OF PETITIONS
Application No. 10/419,621	:	DECISION REFUSING
Filed: April 21, 2003	:	STATUS UNDER
Attorney Docket No. 5266-06201OTV187/ORG/US	:	37 CFR 1.47(a)
For: SUPPORTING COMMON INTERACTIVE	:	
TELEVISION FUNCTIONALITY	:	
THROUGH PRESENTATION ENGINE	:	
SYNTAX	:	

This is a decision on the petition under 37 CFR 1.47(a), filed September 22, 2003.

The petition is **DISMISSED**.

Any request for reconsideration of this decision must be submitted within TWO (2) MONTHS from the mail date of this decision. Extensions of time under 37 CFR 1.136(a) are permitted. Any response should be entitled "Request for Reconsideration of Petition Under 37 CFR 1.47(a)" and may include an oath or declaration executed by the inventor. **Failure to respond will result in abandonment of the application.**

A grantable petition under 37 CFR 1.47(a) requires

- (1) proof that the non-signing inventor cannot be found or reached after diligent effort or that the inventor refuses to sign after having been presented with the application papers (specification, claims, and drawings),
- (2) a proper oath or Declaration executed by the available joint inventor(s),
- (3) the fee of \$130 as specified in 37 CFR § 1.17(h), and
- (4) the last known address of the omitted inventor(s).

In addition to the above requirements, the signing inventors must sign the declaration on behalf of the non-signing inventor. See MPEP 409.03(a).

The instant petition fails to satisfy item (2) above.

The declaration fails to list the citizenship of the non-signing inventor. The declaration fails to list the mailing or residential address for the non-signing inventor.

A proper declaration should be submitted with any request for reconsideration.

Further correspondence with respect to this matter should be addressed as follows:

By mail: Mail Stop Petition
 Commissioner for Patents
 P.O. Box 1450
 Alexandria, VA 22313-1450

Telephone inquiries should be directed to Petitions Attorney Steven Brantley at (703) 306-5683.

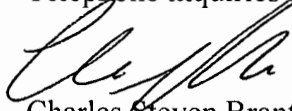

Charles Steven Brantley
Petitions Attorney
Office of Petitions



RECEIVED
NOV 18 2003
OFFICE OF PETITIONS

DECLARATION

As a below named inventor, I hereby declare that:

My residence, post office address, and citizenship are as stated below next to my name.

I believe I am the original, first and sole inventor (if only one name is listed below) or an original, first and joint inventor (if plural names are listed below) of the subject matter which is claimed and for which a patent is sought on the invention entitled "SUPPORTING COMMON INTERACTIVE TELEVISION FUNCTIONALITY THROUGH PRESENTATION ENGINE SYNTAX," the specification of which:

- is attached hereto.
- was filed on April 21, 2003 as Application Serial No. 10/419,621.

I hereby state that I have reviewed and understand the contents of the above-identified specification, including the claims, as amended by any amendment referred to above.

I acknowledge the duty to disclose to the Patent and Trademark Office all information known to me to be material to patentability of the subject matter claimed in this application, as "materiality" is defined in 37 C.F.R. § 1.56.

I hereby claim foreign priority benefits under 35 U.S.C. § 119(a)-(d) or § 365(b) of any foreign application(s) for patent or inventor's certificate listed below, or under § 365(a) of any PCT international application listed below designating least one country other than the United States of America, and have identified below any foreign application for patent or inventor's certificate, or of any PCT international application, having a filing date before that of the application on which priority is claimed.

<u>Prior Foreign Application No.</u>	<u>Country</u>	<u>Filing Date</u> <u>(mm/dd/yy)</u>	<u>Priority</u> <u>Claimed</u>	<u>Cert. copy</u> <u>Attached</u>
_____	_____	_____	_____	_____
_____	_____	_____	_____	_____

I hereby claim the benefit under 35 U.S.C. § 119(e) of any United States provisional application(s) listed below.

<u>Provisional Application No.</u>	<u>Filing Date</u> <u>(mm/dd/yy)</u>
<u>60/373,883</u>	<u>04/19/02</u>
_____	_____

I hereby claim the benefit under 35 U.S.C. § 120 of any United States application(s) listed below, or under § 365(c) of any PCT international application listed below designating the United States of America, and, insofar as the subject matter of each of the claims of this application is not disclosed in the prior United States or PCT international application in the manner provided by the first paragraph of 35 U.S.C. § 112, I acknowledge the duty to disclose all information known to me to be material to the patentability of the subject matter claimed in this application, as "materiality" is defined in 37 C.F.R. § 1.56, which became available between the filing date of the prior application and the national or PCT international filing date of this application.

<u>Parent Application No.</u>	<u>Filing Date</u> <u>(mm/dd/yy)</u>	<u>Parent Patent No. (if applicable) or Status</u>
_____	_____	_____
_____	_____	_____

I hereby declare that all statements made herein of my own knowledge are true and that all statements made herein on information and belief are believed to be true; and further that these statements were made with the knowledge that willful false statements and the like so made are punishable by fine or imprisonment, or both, under 18 U.S.C. § 1001 and that such willful false statements may jeopardize the validity of the application or any patent issued thereon.

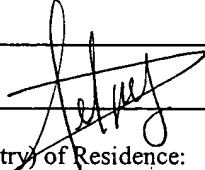
Inventor's Full Name: Alain Delpuch
Inventor's Signature:  Date: June 20, 2003
City and State (or Foreign Country) of Residence: FRANCE Citizenship: FRANCE
Post Office and Residence Address: 34 PARC DES ESSANTS 78690 LESESSANTS LE ROI
(Include number, street name, city, state and zip code)

Inventor's Full Name: _____ James Whitledge
Inventor's Signature: _____ Date: _____
City and State (or Foreign Country) of Residence: _____ Citizenship: _____
Post Office and Residence Address: _____
(Include number, street name, city, state and zip code)

Inventor's Full Name: _____ Jean-Rene Menand
Inventor's Signature: _____ Date: _____
City and State (or Foreign Country) of Residence: _____ Citizenship: _____
Post Office and Residence Address: _____
(Include number, street name, city, state and zip code)

Inventor's Full Name: _____ Emmanuel Barbier
Inventor's Signature:  Date: June 20, 2003
City and State (or Foreign Country) of Residence: FRANCE Citizenship: FRENCH
Post Office and Residence Address: 6 BIS RUE DES ECOLES 75005 PARIS
(Include number, street name, city, state and zip code)

I hereby declare that all statements made herein of my own knowledge are true and that all statements made herein on information and belief are believed to be true; and further that these statements were made with the knowledge that willful false statements and the like so made are punishable by fine or imprisonment, or both, under 18 U.S.C. § 1001 and that such willful false statements may jeopardize the validity of the application or any patent issued thereon.

Inventor's Full Name: Alain Delpuch
Inventor's Signature: _____ Date: _____
City and State (or Foreign Country) of Residence: _____ Citizenship: _____
Post Office and Residence Address: _____
(Include number, street name, city, state and zip code)

Inventor's Full Name: James Whitledge
Inventor's Signature: James R. Whitledge Date: 6/22/03
City and State (or Foreign Country) of Residence: Naperville, IL Citizenship: USA
Post Office and Residence Address: 300345 Bruce Ln, Naperville IL 60563
(Include number, street name, city, state and zip code)

Inventor's Full Name: Jean-Rene Menand
Inventor's Signature: _____ Date: _____
City and State (or Foreign Country) of Residence: _____ Citizenship: _____
Post Office and Residence Address: _____
(Include number, street name, city, state and zip code)

Inventor's Full Name: Emmanuel Barbier
Inventor's Signature: _____ Date: _____
City and State (or Foreign Country) of Residence: _____ Citizenship: _____
Post Office and Residence Address: _____
(Include number, street name, city, state and zip code)

I hereby declare that all statements made herein of my own knowledge are true and that all statements made herein on information and belief are believed to be true; and further that these statements were made with the knowledge that willful false statements and the like so made are punishable by fine or imprisonment, or both, under 18 U.S.C. § 1001 and that such willful false statements may jeopardize the validity of the application or any patent issued thereon.

Inventor's Full Name: _____ Alain Delpuch _____

Inventor's Signature: _____ Date: _____

City and State (or Foreign Country) of Residence: _____ Citizenship: _____

Post Office and Residence Address: _____
(Include number, street name, city, state and zip code)

Inventor's Full Name: _____ James Whitledge _____

Inventor's Signature: _____ Date: _____

City and State (or Foreign Country) of Residence: _____ Citizenship: _____

Post Office and Residence Address: _____
(Include number, street name, city, state and zip code)

Inventor's Full Name: _____ Jean-Rene Menard _____

Inventor's Signature: Jean Rene Menard Date: 7/15/03

City and State (or Foreign Country) of Residence: LOS ALTOS, CA Citizenship: FRANCE

Post Office and Residence Address: 1535 SIESTA DRIVE, LOS ALTOS, CA 94024
(Include number, street name, city, state and zip code)

Inventor's Full Name: _____ Emmanuel Barbier _____

Inventor's Signature: _____ Date: _____

City and State (or Foreign Country) of Residence: _____ Citizenship: _____

Post Office and Residence Address: _____
(Include number, street name, city, state and zip code)

Inventor's Full Name: Kevin Hausman

Inventor's Signature:  Date: 7/6/05

City and State (or Foreign Country) of Residence: Naperville IL Citizenship: US

Post Office and Residence Address: 1105 Manchester Ct, Naperville, IL 60563
(Include number, street name, city, state and zip code)

Inventor's Full Name: _____ Debra Hensgen

Inventor's Signature: _____ Date: _____

City and State (or Foreign Country) of Residence: _____ Citizenship: _____

Post Office and Residence Address: _____
(Include number, street name, city, state and zip code)

Inventor's Full Name: _____ Dongmin Su

Inventor's Signature: _____ Date: _____

City and State (or Foreign Country) of Residence: Santa Clara, CA Citizenship: USA

Post Office and Residence Address: 2038 Finley Place, Santa Clara, CA 95050
(Include number, street name, city, state and zip code)

Inventor's Full Name: Kevin Hausman
Inventor's Signature: _____ Date: _____
City and State (or Foreign Country) of Residence: _____ Citizenship: _____
Post Office and Residence Address: _____
(Include number, street name, city, state and zip code)

Inventor's Full Name: Debra Hensgen
Inventor's Signature: *Debra Hensgen* Date: 07/14/03
City and State (or Foreign Country) of Residence: Redwood City Citizenship: USA
Post Office and Residence Address: 977 Upland Rd Redwood City, CA 94062
(Include number, street name, city, state and zip code)

Inventor's Full Name: _____ Dongmin Su
Inventor's Signature: _____ Date: _____
City and State (or Foreign Country) of Residence: Santa Clara, CA -Citizenship: USA
Post Office and Residence Address: 2038 Finley Place, Santa Clara, CA 95050
(Include number, street name, city, state and zip code)



RECEIVED

NOV 18 2003

OFFICE OF PETITIONS

DECLARATION

As a below named inventor, I hereby declare that:

My residence, post office address, and citizenship are as stated below next to my name.

I believe I am the original, first and sole inventor (if only one name is listed below) or an original, first and joint inventor (if plural names are listed below) of the subject matter which is claimed and for which a patent is sought on the invention entitled "SUPPORTING COMMON INTERACTIVE TELEVISION FUNCTIONALITY THROUGH PRESENTATION ENGINE SYNTAX," the specification of which:

- is attached hereto.
- was filed on April 21, 2003 as Application Serial No. 10/419,621.

I hereby state that I have reviewed and understand the contents of the above-identified specification, including the claims, as amended by any amendment referred to above.

I acknowledge the duty to disclose to the Patent and Trademark Office all information known to me to be material to patentability of the subject matter claimed in this application, as "materiality" is defined in 37 C.F.R. § 1.56.

I hereby claim foreign priority benefits under 35 U.S.C. § 119(a)-(d) or § 365(b) of any foreign application(s) for patent or inventor's certificate listed below, or under § 365(a) of any PCT international application listed below designating least one country other than the United States of America, and have identified below any foreign application for patent or inventor's certificate, or of any PCT international application, having a filing date before that of the application on which priority is claimed.

<u>Prior Foreign Application No.</u>	<u>Country</u>	<u>Filing Date (mm/dd/yy)</u>	<u>Priority Claimed</u>	<u>Cert. copy Attached</u>
_____	_____	_____	_____	_____
_____	_____	_____	_____	_____

I hereby claim the benefit under 35 U.S.C. § 119(e) of any United States provisional application(s) listed below.

<u>Provisional Application No.</u>	<u>Filing Date (mm/dd/yy)</u>
<u>60/373,883</u>	<u>04/19/02</u>
_____	_____

I hereby claim the benefit under 35 U.S.C. § 120 of any United States application(s) listed below, or under § 365(c) of any PCT international application listed below designating the United States of America, and, insofar as the subject matter of each of the claims of this application is not disclosed in the prior United States or PCT international application in the manner provided by the first paragraph of 35 U.S.C. § 112, I acknowledge the duty to disclose all information known to me to be material to the patentability of the subject matter claimed in this application, as "materiality" is defined in 37 C.F.R. § 1.56, which became available between the filing date of the prior application and the national or PCT international filing date of this application.

<u>Parent Application No.</u>	<u>Filing Date (mm/dd/yy)</u>	<u>Parent Patent No. (if applicable) or Status</u>
_____	_____	_____
_____	_____	_____



DECLARATION

RECEIVED
NOV 18 2003

As a below named inventor, I hereby declare that:

My residence, post office address, and citizenship are as stated below next to my name. OFFICE OF PETITIONS

I believe I am the original, first and sole inventor (if only one name is listed below) or an original, first and joint inventor (if plural names are listed below) of the subject matter which is claimed and for which a patent is sought on the invention entitled "SUPPORTING COMMON INTERACTIVE TELEVISION FUNCTIONALITY THROUGH PRESENTATION ENGINE SYNTAX," the specification of which:

- is attached hereto.
- was filed on April 21, 2003 as Application Serial No. 10/419,621.

I hereby state that I have reviewed and understand the contents of the above-identified specification, including the claims, as amended by any amendment referred to above.

I acknowledge the duty to disclose to the Patent and Trademark Office all information known to me to be material to patentability of the subject matter claimed in this application, as "materiality" is defined in 37 C.F.R. § 1.56.

I hereby claim foreign priority benefits under 35 U.S.C. § 119(a)-(d) or § 365(b) of any foreign application(s) for patent or inventor's certificate listed below, or under § 365(a) of any PCT international application listed below designating least one country other than the United States of America, and have identified below any foreign application for patent or inventor's certificate, or of any PCT international application, having a filing date before that of the application on which priority is claimed.

<u>Prior Foreign Application No.</u>	<u>Country</u>	<u>Filing Date (mm/dd/yy)</u>	<u>Priority Claimed</u>	<u>Cert. copy Attached</u>
_____	_____	_____	_____	_____
_____	_____	_____	_____	_____

I hereby claim the benefit under 35 U.S.C. § 119(e) of any United States provisional application(s) listed below.

<u>Provisional Application No.</u>	<u>Filing Date (mm/dd/yy)</u>
<u>60/373,883</u>	<u>04/19/02</u>
_____	_____

I hereby claim the benefit under 35 U.S.C. § 120 of any United States application(s) listed below, or under § 365(c) of any PCT international application listed below designating the United States of America, and, insofar as the subject matter of each of the claims of this application is not disclosed in the prior United States or PCT international application in the manner provided by the first paragraph of 35 U.S.C. § 112, I acknowledge the duty to disclose all information known to me to be material to the patentability of the subject matter claimed in this application, as "materiality" is defined in 37 C.F.R. § 1.56, which became available between the filing date of the prior application and the national or PCT international filing date of this application.

<u>Parent Application No.</u>	<u>Filing Date (mm/dd/yy)</u>	<u>Parent Patent No. (if applicable) or Status</u>
_____	_____	_____
_____	_____	_____

Inventor's Full Name: _____ Kevin Hausman _____

Inventor's Signature: _____ Date: _____

City and State (or Foreign Country) of Residence: _____ Citizenship: _____

Post Office and Residence Address: _____
(Include number, street name, city, state and zip code)

Inventor's Full Name: _____ Debra Hensgen _____

Inventor's Signature: _____ Date: _____

City and State (or Foreign Country) of Residence: _____ Citizenship: _____

Post Office and Residence Address: _____
(Include number, street name, city, state and zip code)

Inventor's Full Name: _____ Dongmin Su _____

Inventor's Signature: _____ Date: _____

City and State (or Foreign Country) of Residence: Santa Clara, CA Citizenship: USA

Post Office and Residence Address: 2038 Finley Place, Santa Clara, CA 95050
(Include number, street name, city, state and zip code)



DA C

IN THE UNITED STATES PATENT AND TRADEMARK OFFICE

RECEIVED

NOV 1 8 2003

OFFICE OF PETITIONS

In re Application of:
Delpuch et al.

§
§
§
§
§
§
§
§
§
§
§
§
§

Group Art Unit: 2611
Examiner: Unknown

Serial No. 10/419,621

Atty. Dkt. No. 5266-06201

Filed: April 21, 2003

For: Supporting Common Interactive
Television Functionality Through
Presentation Engine Syntax

I hereby certify that this correspondence is being deposited with the U.S. Postal Service as First Class Mail in an envelope addressed to: Commissioner for Patents, P.O. Box 1450, Alexandria, VA 22313-1450, on the date indicated below:

Rory D. Rankin
Registered Representative

14 Nov 03
Date Signature

#9

REQUEST FOR RECONSIDERATION OF PETITION UNDER 37 CFR § 1.47(a)

Mail Stop Petitions
Commissioner for Patents
P.O. Box 1450
Alexandria, VA 22313-1450

The United States Patent and Trademark Office is respectfully requested to reconsider the petition under 37 CFR § 1.47(a) submitted by Applicant on September 18, 2003. In the Decision Refusing Status mailed November 3, 2003, the only requirement which was indicated to be missing was an indication on the Declaration as to the non-joining inventor's last known mailing or residential address and citizenship. Applicant submits herewith a corrected Declaration. As noted in the Declaration, the non-joining inventor is a U.S. citizen and his last known address is:

Dongmin Su
2038 Finley Place
Santa Clara, CA 95050
U.S.A.

Should there be any questions the below signed representative may be reached at (512) 853-8866.

If any fees are due, the Commissioner is authorized to charge said fees to Meyertons, Hood, Kivlin, Kowert, & Goetzel, P.C. Deposit Account No. 501505/5266-06201/RDR.

Respectfully submitted,

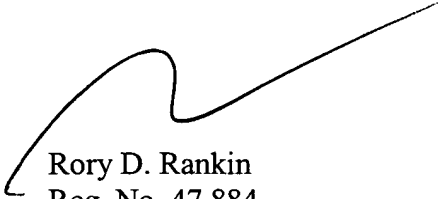

Rory D. Rankin
Reg. No. 47,884
Attorney for Applicants

Meyertons, Hood, Kivlin, Kowert & Goetzel, P.C.
P.O. Box 398
Austin, Texas 78767-0398
Ph: (512) 853-8850

Date: 14 Nov 2003

#12



IN THE UNITED STATES PATENT AND TRADEMARK OFFICE

Inventor Application of:
Delpuch, et al.

Serial No. 10/419,621

Filed: April 21, 2003

For: SUPPORTING COMMON
INTERACTIVE TELEVISION
FUNCTIONALITY THROUGH
PRESENTATION ENGINE SYNTAX

Group Art Unit: 2611
Examiner: Unknown

Atty. Dkt. No. 5266-06201

2611
RECEIVED
JAN 14 2004
TC 2300

I hereby certify that this correspondence is being deposited with the U.S. Postal Service as First Class Mail in an envelope addressed to: Commissioner for Patents, P.O. Box 1450, Alexandria, VA 22313-1450, on the date indicated below:

Rory D. Rankin
Registered Representative

1/8/04
Date

Signature

RECEIVED

INFORMATION DISCLOSURE STATEMENT

JAN 14 2004

Commissioner for Patents
P.O. Box 1450
Alexandria, VA 22313-1450

Technology Center 2600

Sir:

Applicant requests consideration of the references listed on the attached Form PTO-1449 and/or the additional information identified below in paragraph 3.

- A copy of each required reference listed on the Form PTO-1449 is enclosed.
- The references listed on the Form PTO-1449 were previously cited in application serial no. _____ to which the captioned application is seeking priority under 35 U.S.C. §120; therefore, a copy of each reference is not enclosed.
- The present application is a U.S. national patent application filed after June 30, 2003, or an international application that entered the national stage under 35 USC § 371 after June 30, 2003. Therefore, copies of the cited U.S. patents and/or U.S. patent application publications are not enclosed.

1. This Information Disclosure Statement is submitted:

- a. within 3 months of the filing date of a national application other than a continued prosecution application under § 1.53(d);
- within 3 months of the date of entry of the national stage as set forth in § 1.491 in an International application;
- before the mailing date of a first Office Action on the merits; or
- before the mailing of a first Office Action after the filing of a request for continued examination under § 1.114.

- b. after the events of above paragraph 1a and prior to the mailing date of a final Office Action or Notice of Allowance, and thus: the certification of paragraph 2 below is provided, or a fee of \$180.00 is enclosed.
- c. after the mailing date of a final Office Action or a Notice of Allowance and prior to payment of the issue fee, and thus: the certification of paragraph 2 below is provided and a fee of \$180.00 is enclosed.

2. It is hereby certified:

- that each item of information contained in this Information Disclosure Statement was cited in a communication from a foreign patent office in a counterpart foreign application not more than three months prior to the filing of the Statement, or
- that no item of information contained in the Information Disclosure Statement was cited in a communication from a foreign patent office in a counterpart foreign application or, to the knowledge of the person signing the certification after making reasonable inquiry, was known to any individual designated in § 1.56 (c) more than three months prior to the filing of the Statement.

3. Consideration of the following additional information (including any co-pending or abandoned U.S. applications, prior uses and/or sales, etc.) is requested:

4. For each non-English language reference listed on the attached Form PTO-1449:

- reference is made to an English language translation submitted herewith, and/or
- reference is made to a foreign patent office search report (in the English language) submitted herewith, and/or
- reference is made to an English language translation of a foreign patent office search report submitted herewith, and/or
- reference is made to the concise explanation contained in the specification of the present application at page(s) _____, and/or
- reference is made to the concise explanation set forth below:

5. Applicant also offers the following comments for the Examiner's consideration:

6. Also enclosed is a copy of a foreign search report citing these references.

7. The listed documents were brought to the attention of the Applicant(s) after payment of the issue fee in the captioned case. The documents were cited in a communication from a foreign patent office in a counterpart foreign application not more than three months prior to the filing of this Information Disclosure Statement. Applicant(s) request this Information Disclosure Statement and attached Form PTO-1449 be placed in the file of the captioned application.

8. Applicant(s) requests that the Information Disclosure Statement and attached Form PTO-1449 and references, which are being filed before the grant of the patent and pursuant to 37 C.F.R. § 1.97(i), be placed in the file of the captioned application.

If any required fees are missing, the Commissioner is authorized to charge said fees to Meyertons, Hood, Kivlin, Kowert & Goetzel, P.C. Deposit Account No. 501505/5266-06201/RDR.

Respectfully submitted,

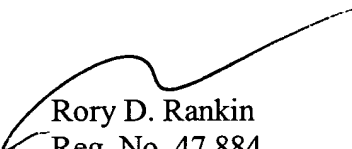
Rory D. Rankin
Reg. No. 47,884
Attorney for Applicant(s)

MEYERTONS, HOOD, KIVLIN,
KOWERT & GOETZEL, P.C.
P. O. Box 398
Austin, Texas 78767
(512) 853-8800

Date: 1/3/04

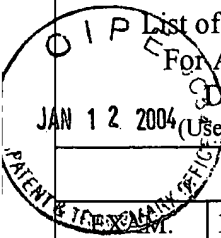

Form PTO-1449 (modified) List of Patents and Publications For Applicant's Information Disclosure Statement (Use several sheets if necessary)	ATTY. DKT. NO. 5266-06201 APPLICANT: Delpuch, et al. FILING DATE: April 21, 2003	SERIAL NO. 10/419,621 GROUP: 2611
---	--	--

U.S. PATENT DOCUMENTS

INITIALS	REF. DES.	DOCUMENT NUMBER	DATE	NAME	CLASS	SUB CLASS	FILING DATE APPROPRIATE
	B1	6,539,359	03/25/2003	Ladd, et al.			
	B2	6,415,303	07/02/2002	Meier, et al.			JAN 14 2004
	B3	6,188,401	02/13/2001	Peyer			Technology Center 2600
	B4	5,790,198	08/04/1998	Roop, et al.			

FOREIGN PATENT DOCUMENTS

EXAM. INITIALS	REF. DES.	DOCUMENT NUMBER	DATE	COUNTRY	CLASS	SUB CLASS	TRANSLATIO YES/NO

OTHER ART (Including Author, Title, Date, Pertinent Pages, Etc.)

	B5	"CSS3 Module: The Box Model"; W3C Working Draft, July 26, 2001; This version: http://www.w3.org/TR/2001/WD-css3-box-20010726 ; Latest version: http://www.w3.org/TR/css3-box ; Editor: Bert Bos; Copyright ©2001 W3C® (MIT, INRIA, Keio); Pages 1-104.					

EXAMINER: _____ DATE CONSIDERED: _____

EXAMINER: Initial if citation considered, whether or not citation is in conformance with MPEP 609; Draw line through citation if not in conformance and not considered. Include copy of this form with next communication to the patent owner.



Paper No. 11

MEYERTONS, HOOD, KIVLIN, KOWERT & GOETZEL, P.C.
P.O. BOX 398
AUSTIN, TX 78767-0398

COPY MAILED

JAN 12 2004

OFFICE OF PETITIONS

In re Application of	:	
Delpuch et al.	:	DECISION ACCORDING
Application No. 10/419,621	:	STATUS UNDER
Filed: April 21, 2003	:	37 CFR 1.47(a)
Attorney Docket No. 5266-06201OTV187/ORG/US	:	
For: SUPPORTING COMMON INTERACTIVE	:	
TELEVISION FUNCTIONALITY	:	
THROUGH PRESENTATION ENGINE	:	
SYNTAX	:	

This is a decision on the renewed petition under 37 CFR 1.47(a), filed November 13, 2003.

The petition is **granted**.

Petitioner has shown that the non-signing inventor has refused to join in the filing of the above-identified application after having been presented with the application papers or cannot be located.

The above-identified application and papers have been reviewed and found in compliance with 37 CFR 1.47(a). This application is hereby accorded Rule 1.47(a) status.

As provided in Rule 1.47(c), this Office will forward notice of this application's filing to the non-signing inventor at the address given in the petition. Notice of the filing of this application will also be published in the Official Gazette.

After this decision is mailed, the above-identified application will be returned to the Office of Initial Patent Examination for further processing.

Telephone inquiries should be directed to Petitions Attorney Steven Brantley at (703) 306-5683.

Charles Steven Brantley
Petitions Attorney
Office of Petitions



Paper No. 12

Dongmin Su
2038 Finley Place
Santa Clara, CA 95050

COPY MAILED

JAN 12 2004

OFFICE OF PETITIONS

In re Application of :
Delpuch et al. :
Application No. 10/419,621 :
Filed: April 21, 2003 :
Attorney Docket No. 5266-06201OTV187/ORG/US :
For: SUPPORTING COMMON INTERACTIVE :
TELEVISION FUNCTIONALITY :
THROUGH PRESENTATION ENGINE :
SYNTAX :

Letter

Dear Mr. Su:

You are named as a joint inventor in the above identified United States patent application, filed under the provisions of 35 U.S.C. 116 (United States Code), and 37 CFR 1.47(a), Rules of Practice in Patent Cases. Should a patent be granted on the application you will be designated therein as a joint inventor.

As a named inventor you are entitled to inspect any paper in the file wrapper of the application, order copies of all or any part thereof (at a prepaid cost per 37 CFR 1.19) or make your position of record in the application. Alternatively, you may arrange to do any of the preceding through a registered patent attorney or agent presenting written authorization from you. If you care to join the application, counsel of record (see below) would presumably assist you. Joining in the application would entail the filing of an appropriate oath or declaration by you pursuant to 37 CFR 1.63.

Requests for information regarding your application should be directed to the File Information Unit at (703)308-2733. Information regarding how to pay for and order a copy of the application, or a specific paper in the application, should be directed to Certification Division at (703)308-9726 or 1(800)972-6382 (outside the Washington D.C. area).

Telephone inquiries regarding this communication should be directed to Petitions Attorney Steven Brantley at (703) 306-5683.

Charles Steven Brantley
Petitions Attorney
Office of Petitions

cc: MEYERTONS, HOOD, KIVLIN, KOWERT & GOETZEL, P.C.
P.O. BOX 398
AUSTIN, TX 78767-0398

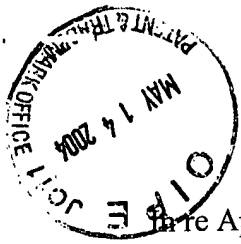

FILE COPY

Receipt

#13

W. Lawson
7/14/04

IN THE UNITED STATES PATENT AND TRADEMARK OFFICE

In re Application of:
Delpuch, et al.

Serial No. 10/419,621

Filed: April 21, 2003

For: SUPPORTING COMMON
INTERACTIVE TELEVISION
FUNCTIONALITY THROUGH
PRESENTATION ENGINE SYNTAX



Group Art Unit: 2611
Examiner: Unknown

Atty. Dkt. No. 5266-06201

I hereby certify that this correspondence is being deposited with the U.S. Postal Service as First Class Mail in an envelope addressed to: Commissioner for Patents, P.O. Box 1450, Alexandria, VA 22313-1450, on the date indicated below:

Rory D. Rankin
Registered Representative

5/11/04
Date

Signature

REQUEST FOR CORRECTED OFFICIAL FILING RECEIPT

Commissioner for Patents
P.O. Box 1450
Alexandria, VA 22313-1450

RECEIVED

JUN 10 2004

Sir:

Technology Center 2600

The official Filing Receipt mailed April 8, 2004, lists two of the Applicant's residences incorrectly. The correct residences should be Alain Delpuch, Les Essarts Le Roi, FRANCE and Kevin Hausman, Naperville, IL. I have provided a copy of the Filing Receipt with the change noted thereon. Applicants respectfully request that this change be made and a corrected Filing Receipt be reissued in the above-identified application.

Respectfully submitted,

Rory D. Rankin
Reg. No. 47,884
Attorney for Applicant(s)

MEYERTONS, HOOD, KIVLIN,
KOWERT & GOETZEL, P.C.
P. O. Box 398
Austin, Texas 78767
(512) 853-8800

Date: 5/11/04

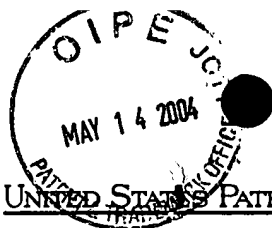

UNITED STATES PATENT AND TRADEMARK OFFICE

UNITED STATES DEPARTMENT OF COMMERCE
 United States Patent and Trademark Office
 Address: COMMISSIONER FOR PATENTS
 P.O. Box 1450
 Alexandria, Virginia 22313-1450
 www.uspto.gov

APPL NO.	FILING OR 371 (c) DATE	ART UNIT	FIL FEE REC'D	ATTY. DOCKET NO	DRAWINGS	TOT CLMS	IND CLMS
10/419,621	04/21/2003	2611	1018	5266-06201	5	23	4

CONFIRMATION NO. 2305

UPDATED FILING RECEIPT



OC00000012304475

35690
 MEYERTONS, HOOD, KIVLIN, KOWERT & GOETZEL, P.C.
 P.O. BOX 398
 AUSTIN, TX 78767-0398

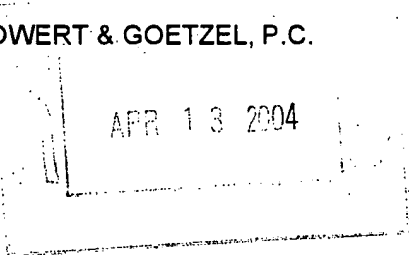

Date Mailed: 04/08/2004

Receipt is acknowledged of this regular Patent Application. It will be considered in its order and you will be notified as to the results of the examination. Be sure to provide the U.S. APPLICATION NUMBER, FILING DATE, NAME OF APPLICANT, and TITLE OF INVENTION when inquiring about this application. Fees transmitted by check or draft are subject to collection. Please verify the accuracy of the data presented on this receipt. If an error is noted on this Filing Receipt, please write to the Office of Initial Patent Examination's Filing Receipt Corrections, facsimile number 703-746-9195. Please provide a copy of this Filing Receipt with the changes noted thereon. If you received a "Notice to File Missing Parts" for this application, please submit any corrections to this Filing Receipt with your reply to the Notice. When the USPTO processes the reply to the Notice, the USPTO will generate another Filing Receipt incorporating the requested corrections (if appropriate).

Applicant(s)

Les Essarts Le Roi

Alain Delpuch, ~~Les Essarts Le Roi, FRANCE;~~
 James Whitledge, Naperville, IL;
 Jean-Rene Menand, Los Altos, CA;
 Emmanuel Barbier, Paris, FRANCE;
 Kevin Hausman, ~~Naperville, IL;~~ *Naperville, IL*
 Debra Hensgen, Redwood City, CA;
 Dongmin Su, Santa Clara, CA;

Atty Dkt#: _____ Atty: *RDR*
 Transferred Due Date: _____
 Action: 30 Day 1 Mo. 2 Mo.
 3 Mo. Final Action Advcy Action
 Ntc of Allow Drawings Issue Fee
 Other: _____
 Docketed: _____

Domestic Priority data as claimed by applicant

This appin claims benefit of 60/373,883 04/19/2002

Foreign Applications

If Required, Foreign Filing License Granted: 06/17/2003

Projected Publication Date: 07/15/2004

Non-Publication Request: No

Early Publication Request: No

Title

RECEIVED

JUN 10 2004

Technology Center 2600

Supporting common interactive television functionality through presentation engine syntax

Preliminary Class

725

**LICENSE FOR FOREIGN FILING UNDER
Title 35, United States Code, Section 184
Title 37, Code of Federal Regulations, 5.11 & 5.15**

GRANTED

The applicant has been granted a license under 35 U.S.C. 184, if the phrase "IF REQUIRED, FOREIGN FILING LICENSE GRANTED" followed by a date appears on this form. Such licenses are issued in all applications where the conditions for issuance of a license have been met, regardless of whether or not a license may be required as set forth in 37 CFR 5.15. The scope and limitations of this license are set forth in 37 CFR 5.15(a) unless an earlier license has been issued under 37 CFR 5.15(b). The license is subject to revocation upon written notification. The date indicated is the effective date of the license, unless an earlier license of similar scope has been granted under 37 CFR 5.13 or 5.14.

This license is to be retained by the licensee and may be used at any time on or after the effective date thereof unless it is revoked. This license is automatically transferred to any related applications(s) filed under 37 CFR 1.53(d). This license is not retroactive.

The grant of a license does not in any way lessen the responsibility of a licensee for the security of the subject matter as imposed by any Government contract or the provisions of existing laws relating to espionage and the national security or the export of technical data. Licensees should apprise themselves of current regulations especially with respect to certain countries, of other agencies, particularly the Office of Defense Trade Controls, Department of State (with respect to Arms, Munitions and Implements of War (22 CFR 121-128)); the Office of Export Administration, Department of Commerce (15 CFR 370.10 (j)); the Office of Foreign Assets Control, Department of Treasury (31 CFR Parts 500+) and the Department of Energy.

NOT GRANTED

No license under 35 U.S.C. 184 has been granted at this time, if the phrase "IF REQUIRED, FOREIGN FILING LICENSE GRANTED" DOES NOT appear on this form. Applicant may still petition for a license under 37 CFR 5.12, if a license is desired before the expiration of 6 months from the filing date of the application. If 6 months has lapsed from the filing date of this application and the licensee has not received any indication of a secrecy order under 35 U.S.C. 181, the licensee may foreign file the application pursuant to 37 CFR 5.15(b).



ELECTRONIC INFORMATION DISCLOSURE STATEMENT

Electronic Version v18
Stylesheet Version v18.0

Title of Invention	Supporting Common Interactive Television Functionality Through Presentation Engine Syntax																				
<p>Application Number: 10/419621 </p> <p>Confirmation Number: 2305</p> <p>First Named Applicant: Alain Delpuch</p> <p>Attorney Docket Number: 5266-06201</p> <p>Art Unit: 2611</p> <p>Examiner: Kieu Oanh T Bui</p> <p>Search string: (6345307).pn.</p>																					
<p style="font-size: 24px; font-weight: bold;">RECEIVED</p> <p style="font-size: 18px;">JUL 01 2004</p> <p>Technology Center 2600</p>																					
<p><u>Certification:</u> This Information Disclosure Statement was submitted under the following conditions, which satisfies the requirement under 37 CFR 1.97(e). The filer certified:</p> <p>That each item of information contained in the information disclosure statement was first cited in any communication from a foreign patent office in a counterpart foreign application not more than three months prior to the filing of the information disclosure statement.</p> <p>US Patent Documents</p> <p>Note: Applicant is not required to submit a paper copy of cited US Patent Documents</p> <table border="1" style="width: 100%; border-collapse: collapse; text-align: center;"> <thead> <tr> <th style="width: 5%;">init</th> <th style="width: 15%;">Cite.No.</th> <th style="width: 15%;">Patent No.</th> <th style="width: 15%;">Date</th> <th style="width: 15%;">Patentee</th> <th style="width: 5%;">Kind</th> <th style="width: 5%;">Class</th> <th style="width: 5%;">Subclass</th> </tr> </thead> <tbody> <tr> <td></td> <td>1</td> <td>6345307</td> <td>2002-02-05</td> <td>Booth</td> <td></td> <td></td> <td></td> </tr> </tbody> </table> <p>Signature</p> <table border="1" style="width: 100%; border-collapse: collapse; margin-top: 10px;"> <tr> <td style="width: 60%; text-align: center; padding: 5px;">Examiner Name</td> <td style="width: 40%; text-align: center; padding: 5px;">Date</td> </tr> <tr> <td style="height: 20px;"></td> <td style="height: 20px;"></td> </tr> </table>		init	Cite.No.	Patent No.	Date	Patentee	Kind	Class	Subclass		1	6345307	2002-02-05	Booth				Examiner Name	Date		
init	Cite.No.	Patent No.	Date	Patentee	Kind	Class	Subclass														
	1	6345307	2002-02-05	Booth																	
Examiner Name	Date																				



Electronic Filing System (EFS) Data
Electronic Patent Application Submission
USPTO Use Only

#14
W. Lawyer
7/14/04

EFS ID: 63466
Application ID: 10419621
Title of Invention: Supporting Common Interactive
Television Functionality Through
Presentation Engine Syntax
First Named Inventor: Alain Delpuch
Domestic/Foreign Application: Domestic Application
Filing Date: 2003-04-21
Effective Receipt Date: 2004-06-28
Submission Type: Information Disclosure
Statement
Filing Type:
Confirmation number: 2305
Attorney Docket Number: 5266-06201



RECEIVED
JUL 01 2004
Technology Center 2600

Total Fees Authorized:

Digital Certificate Holder: cn=Rory D. Rankin,ou=Registered Attorneys,ou=Patent and Trademark
Office,ou=Department of Commerce,o=U.S. Government,c=US
Certificate Message Digest: c3da810a2c7da22441c4c154d9b6eb27ec231476



TRANSMITTAL

Electronic Version v1.1
 Stylesheet Version v1.1.0

Title of Invention	Supporting Common Interactive Television Functionality Through Presentation Engine Syntax
---------------------------	---

Application Number: 10/419621		RECEIVED
Date: 2003-04-21		JUL 01 2004
First Named Applicant: Alain Delpuch		Technology Center 2600
Confirmation Number: 2305		
Attorney Docket Number: 5266-06201		

I hereby certify that the use of this system is for OFFICIAL correspondence between patent applicants or their representatives and the USPTO. Fraudulent or other use besides the filing of official correspondence by authorized parties is strictly prohibited, and subject to a fine and/or imprisonment under applicable law.

I, the undersigned, certify that I have viewed a display of document(s) being electronically submitted to the United States Patent and Trademark Office, using either the USPTO provided style sheet or software, and that this is the document(s) I intend for initiation or further prosecution of a patent application noted in the submission. This document(s) will become part of the official electronic record at the USPTO.

Submitted by:	Elec. Sign.	Sign. Capacity
Rory D. Rankin Registered Number: 47,884	Rory D. Rankin	Attorney

Documents being submitted	Files
us-ids	5266-06201IDS-usidst.xml
	us-ids.dtd
	us-ids.xsl

Comments

If any required fees are missing, the Commissioner is authorized to charge said fees to

Meyertons, Hood, Kivlin, Kowert and Goetzel, P.C. Deposit Account No. 501505/5266-06201/RDR

L Number	Hits	Search Text	DB	Time stamp
27	8391	725/\$.ccls.	USPAT; US-PGPUB; EPO	2004/09/23 17:45
28	912	725/\$.ccls. and HTML	USPAT; US-PGPUB; EPO	2004/09/23 17:47
29	475	(725/\$.ccls. and HTML) and "markup language"	USPAT; US-PGPUB; EPO	2004/09/23 18:06
30	24	((725/\$.ccls. and HTML) and "markup language") and "scripting language"	USPAT; US-PGPUB; EPO	2004/09/23 18:06
31	2	((((725/\$.ccls. and HTML) and "markup language") and "scripting language") and "proxy server"	USPAT; US-PGPUB; EPO	2004/09/23 17:46
32	2314	"proxy server" and HTML	USPAT; US-PGPUB; EPO	2004/09/23 17:48
33	1412	("proxy server" and HTML) and "markup language"	USPAT; US-PGPUB; EPO	2004/09/23 17:48
34	157	((("proxy server" and HTML) and "markup language") and "scripting language"	USPAT; US-PGPUB; EPO	2004/09/23 17:49
35	118	((("proxy server" and HTML) and "markup language") and "scripting language") and interactive	USPAT; US-PGPUB; EPO	2004/09/23 17:49
36	80	((("proxy server" and HTML) and "markup language") and "scripting language") and interactive) and (TV or television)	USPAT; US-PGPUB; EPO	2004/09/23 17:50
37	59	(((((("proxy server" and HTML) and "markup language") and "scripting language") and interactive) and (TV or television))) and META	USPAT; US-PGPUB; EPO	2004/09/23 17:51
38	1	((((((("proxy server" and HTML) and "markup language") and "scripting language") and interactive) and (TV or television))) and META) and "DVB-MHP"	USPAT; US-PGPUB; EPO	2004/09/23 17:51
39	34	((((((("proxy server" and HTML) and "markup language") and "scripting language") and interactive) and (TV or television))) and META) and "style sheet"	USPAT; US-PGPUB; EPO	2004/09/23 18:06
40	2	((((((("proxy server" and HTML) and "markup language") and "scripting language") and interactive) and (TV or television))) and META) and "style sheet") and (time near8 expiration)	USPAT; US-PGPUB; EPO	2004/09/23 17:54
41	34	((((((("proxy server" and HTML) and "markup language") and "scripting language") and interactive) and (TV or television))) and META) and "style sheet") and (subset or resource)	USPAT; US-PGPUB; EPO	2004/09/23 17:55
42	32	((((((("proxy server" and HTML) and "markup language") and "scripting language") and interactive) and (TV or television))) and META) and "style sheet") and (subset or resource)) and (video and audio and graphics)	USPAT; US-PGPUB; EPO	2004/09/23 17:55
43	32	((((((("proxy server" and HTML) and "markup language") and "scripting language") and interactive) and (TV or television))) and META) and "style sheet") and (subset or resource)) and (video and audio and graphics)) and (client or user)	USPAT; US-PGPUB; EPO	2004/09/23 17:56
44	1	((((((("proxy server" and HTML) and "markup language") and "scripting language") and interactive) and (TV or television))) and META) and "style sheet") and (subset or resource)) and (video and audio and graphics)) and (client or user)) and AIT	USPAT; US-PGPUB; EPO	2004/09/23 17:57
45	32	((((((("proxy server" and HTML) and "markup language") and "scripting language") and interactive) and (TV or television))) and META) and "style sheet") and (subset or resource)) and (video and audio and graphics)) and (client or user)) and DTD	USPAT; US-PGPUB; EPO	2004/09/23 17:57
46	31	((((((("proxy server" and HTML) and "markup language") and "scripting language") and interactive) and (TV or television))) and META) and "style sheet") and (subset or resource)) and (video and audio and graphics)) and (client or user)) and DTD) and (television near3 content)	USPAT; US-PGPUB; EPO	2004/09/23 17:57

47	31	((((((((("proxy server" and HTML) and "markup language") and "scripting language") and interactive) and (TV or television)) and META) and "style sheet") and (subset or resource)) and (video and audio and graphics)) and (client or user)) and DTD) and (television near3 content)) and (attribute or directive)	USPAT; US-PGPUB; EPO	2004/09/23 17:59
48	1	((((((((("proxy server" and HTML) and "markup language") and "scripting language") and interactive) and (TV or television)) and META) and "style sheet") and (subset or resource)) and (video and audio and graphics)) and (client or user)) and DTD) and (television near3 content)) and (attribute or directive)) and ("declarative data essence" or DDE)	USPAT; US-PGPUB; EPO	2004/09/23 17:59
49	29	((((((((("proxy server" and HTML) and "markup language") and "scripting language") and interactive) and (TV or television)) and META) and "style sheet") and (subset or resource)) and (video and audio and graphics)) and (client or user)) and DTD) and (television near3 content)) and (attribute or directive)	USPAT	2004/09/23 18:00
50	0	((((((((("proxy server" and HTML) and "markup language") and "scripting language") and interactive) and (TV or television)) and META) and "style sheet") and (subset or resource)) and (video and audio and graphics)) and (client or user)) and DTD) and (television near3 content)) and (attribute or directive)) and "META name"	USPAT; US-PGPUB; EPO	2004/09/23 18:00
51	0	((((((((("proxy server" and HTML) and "markup language") and "scripting language") and interactive) and (TV or television)) and META) and "style sheet") and (subset or resource)) and (video and audio and graphics)) and (client or user)) and DTD) and (television near3 content)) and (attribute or directive)) and (META near3 name)	USPAT; US-PGPUB; EPO	2004/09/23 18:00
52	0	((((((((("proxy server" and HTML) and "markup language") and "scripting language") and interactive) and (TV or television)) and META) and "style sheet") and (subset or resource)) and (video and audio and graphics)) and (client or user)) and DTD) and (television near3 content)) and (attribute or directive)) and (resource near8 requirement)	USPAT; US-PGPUB; EPO	2004/09/23 18:01
53	29	((((((((("proxy server" and HTML) and "markup language") and "scripting language") and interactive) and (TV or television)) and META) and "style sheet") and (subset or resource)) and (video and audio and graphics)) and (client or user)) and DTD) and (television near3 content)) and (attribute or directive)) and (web or internet or WWW)	USPAT; US-PGPUB; EPO	2004/09/23 18:02
54	29	((((((((("proxy server" and HTML) and "markup language") and "scripting language") and interactive) and (TV or television)) and META) and "style sheet") and (subset or resource)) and (video and audio and graphics)) and (client or user)) and DTD) and (television near3 content)) and (attribute or directive)) and (web or internet or WWW)) and (detect\$ and prohibit\$3)	USPAT; US-PGPUB; EPO	2004/09/23 18:05
55	1	725/\$.ccls. and (((((((("proxy server" and HTML) and "markup language") and "scripting language") and interactive) and (TV or television)) and META) and "style sheet") and (subset or resource)) and (video and audio and graphics)) and (client or user))	USPAT; US-PGPUB; EPO	2004/09/23 18:05
56	573	725/\$.ccls. and "markup language"	USPAT; US-PGPUB; EPO	2004/09/23 18:06
57	26	(725/\$.ccls. and "markup language") and "scripting language"	USPAT; US-PGPUB; EPO	2004/09/23 18:06
58	4	((725/\$.ccls. and "markup language") and "scripting language") and "style sheet"	USPAT; US-PGPUB; EPO	2004/09/23 18:06

PRQ



UNITED STATES PATENT AND TRADEMARK OFFICE

UNITED STATES DEPARTMENT OF COMMERCE
United States Patent and Trademark Office
Address: COMMISSIONER FOR PATENTS
P.O. Box 1450
Alexandria, Virginia 22313-1450
www.uspto.gov

APPLICATION NO.	FILING DATE	FIRST NAMED INVENTOR	ATTORNEY DOCKET NO.	CONFIRMATION NO.
10/419,621	04/21/2003	Alain Delpuch	5266-06201	2305

44015 7590 10/15/2004

OPTV/MEYERTONS
THE CHASE BUILDING
700 LAVACA, SUITE 800
AUSTIN, TX 78701

EXAMINER

BUI, KIEU OANH T

ART UNIT	PAPER NUMBER
----------	--------------

2611

DATE MAILED: 10/15/2004

Please find below and/or attached an Office communication concerning this application or proceeding.

Office Action Summary	Application No. 10/419,621	Applicant(s) ALAIN DELPUCH ET AL.	
	Examiner KIEU-OANH T BUI	Art Unit 2611	

-- The MAILING DATE of this communication appears on the cover sheet with the correspondence address --

Period for Reply

A SHORTENED STATUTORY PERIOD FOR REPLY IS SET TO EXPIRE 3 MONTH(S) FROM THE MAILING DATE OF THIS COMMUNICATION.

- Extensions of time may be available under the provisions of 37 CFR 1.136(a). In no event, however, may a reply be timely filed after SIX (6) MONTHS from the mailing date of this communication.
- If the period for reply specified above is less than thirty (30) days, a reply within the statutory minimum of thirty (30) days will be considered timely.
- If NO period for reply is specified above, the maximum statutory period will apply and will expire SIX (6) MONTHS from the mailing date of this communication.
- Failure to reply within the set or extended period for reply will, by statute, cause the application to become ABANDONED (35 U.S.C. § 133). Any reply received by the Office later than three months after the mailing date of this communication, even if timely filed, may reduce any earned patent term adjustment. See 37 CFR 1.704(b).

Status

- 1) Responsive to communication(s) filed on _____.
- 2a) This action is **FINAL**. 2b) This action is non-final.
- 3) Since this application is in condition for allowance except for formal matters, prosecution as to the merits is closed in accordance with the practice under *Ex parte Quayle*, 1935 C.D. 11, 453 O.G. 213.

Disposition of Claims

- 4) Claim(s) 1-23 is/are pending in the application.
4a) Of the above claim(s) _____ is/are withdrawn from consideration.
- 5) Claim(s) _____ is/are allowed.
- 6) Claim(s) 1-23 is/are rejected.
- 7) Claim(s) _____ is/are objected to.
- 8) Claim(s) _____ are subject to restriction and/or election requirement.

Application Papers

- 9) The specification is objected to by the Examiner.
- 10) The drawing(s) filed on _____ is/are: a) accepted or b) objected to by the Examiner.
Applicant may not request that any objection to the drawing(s) be held in abeyance. See 37 CFR 1.85(a).
Replacement drawing sheet(s) including the correction is required if the drawing(s) is objected to. See 37 CFR 1.121(d).
- 11) The oath or declaration is objected to by the Examiner. Note the attached Office Action or form PTO-152.

Priority under 35 U.S.C. § 119

- 12) Acknowledgment is made of a claim for foreign priority under 35 U.S.C. § 119(a)-(d) or (f).
a) All b) Some * c) None of:
1. Certified copies of the priority documents have been received.
 2. Certified copies of the priority documents have been received in Application No. _____.
 3. Copies of the certified copies of the priority documents have been received in this National Stage application from the International Bureau (PCT Rule 17.2(a)).

* See the attached detailed Office action for a list of the certified copies not received.

Attachment(s)

- | | |
|--|---|
| 1) <input checked="" type="checkbox"/> Notice of References Cited (PTO-892) | 4) <input type="checkbox"/> Interview Summary (PTO-413)
Paper No(s)/Mail Date. _____ |
| 2) <input type="checkbox"/> Notice of Draftsperson's Patent Drawing Review (PTO-948) | 5) <input type="checkbox"/> Notice of Informal Patent Application (PTO-152) |
| 3) <input checked="" type="checkbox"/> Information Disclosure Statement(s) (PTO-1449 or PTO/SB/08)
Paper No(s)/Mail Date <u>1-3</u> . | 6) <input type="checkbox"/> Other: _____ |

NFLE 1002 - Page 279

DETAILED ACTION

Claim Rejections - 35 USC 102

1. The following is a quotation of the appropriate paragraphs of 35 U.S.C. 102 that form the basis for the rejections under this section made in this Office action:

*A person shall be entitled to a patent unless --
(e) the invention was described in (1) an application for patent, published under section 122(b), by another filed in the United States before the invention by the applicant for patent or (2) a patent granted on an application for patent by another filed in the United States before the invention by the applicant for patent, except that an international application filed under the treaty defined in section 351(a) shall have the effects for purposes of this subsection of an application filed in the United States only if the international application designated the United States and was published under Article 21(2) of such treaty in the English language.*

2. Claims 1-7, 11-16, and 20-23 are rejected under 35 U.S.C. 102(e) as being anticipated by Ben-Shaul et al. (U.S. Patent Pub No. 2002/0010798 A1/or “Ben” for short).

Regarding claim 1, Ben discloses “a method comprising: receiving one or more directives, wherein said directives are indicative of an audio, video and/or graphic presentation requiring a set of resources; determining from said directives that acquisition of a subset of said resources are a prerequisite to the presenting of said presentation; and prohibiting the presenting of said presentation until said subset of resources are acquired”, i.e., Ben discloses a content and application delivery system that a user or a web client (as illustrated in Figs. 6-7) can receive one or more directives which indicative of audio, video and/or graphics presentation—content delivery from web servers to the user via a TV browser for local news and local sports and etc. (page 3/section 0027, page 5/sect. 0051, page 22/sect. 0221 & 0231, and page 24/sect. 0256 & 0263), the system has directive director 122 (Fig. 12, and page 35/section 0431 & 0432) has a control over the content delivery to the user based on service profile and other directives that can

Art Unit: 2611

either authorize or disable the service/ content delivery for presentation at the user's location if subset of resources are not acquired, for instance, the user is not subscribed so that some of required directives for billing is not acquired, the service is unauthorized or disabled (page 27/from section 0314 to section 0324).

As for claim 2, Ben discloses "wherein said subset of resources are indicated using directives selected from the group consisting of: a markup language, a scripting language, and a style sheet" (page 14/sections 0195, 0196, 0197 for all of these features for CDSL, XML, and XML style sheet language).

As for claim 3, Ben discloses "wherein said directives are received by a proxy server in an interactive television system" (page 37/section 0477 to section 0480 as the content marker as interactive tool to use in GUI editor and TV system –page 24/sect. 0256; and edge server 48 acts as a proxy server).

As for claim 4, Ben also discloses "wherein said determining is performed by said proxy server, and wherein said method further comprises said proxy server conveying signals which correspond to said subset of resources to a remote client device", i.e., the edge server directs the right subset of resources to the remote client device (page 24/section 0260 to page 25/section 0268 for redirecting contents and resources to the client).

As for claim 5, Ben discloses further "comprising said client device acquiring said subset of resources in response to detecting said signals", i.e., the client can obtain a subset of resources with the use of directive editor 122 for filtering and detecting the appropriate content from the edge server (page 35/section 0431 to page 36/section 0435).

Art Unit: 2611

As for claim 6, Ben further shows “wherein said subset comprises streaming audio and/or video, and wherein acquisition of the streaming audio and/or video comprises configuring hardware resources within said client device” (page 2/section 0019 & page 35/section 0425 for streaming media audio and video; and page 22/section 0230 & 0231 and page 26/section 0309-0312 for hardware configuration as configuration on targeting based on profiles, caching, mirroring, priorities of communication and processing, streaming media support etc. within the client device for receiving the content from different resources).

As for claim 7, Ben discloses “wherein acquisition of the subset of resources comprises the client device initiating requests for remotely located resources to be conveyed to said client device” (as shown in Figs. 3-4, the client device at 14 is remotely located from resource local ISP or server 10; and the client can initiate the requests, page 37/section 0486 to page 38/section 0490 as the client requests for a personal “client view”).

As for claim 11, Ben discloses further “comprising defining a META name/value pair, wherein said name is indicative that said-corresponding-value-is a prerequisite-resource” (page 14/section 0192 for a meta value CDML code identified by two entities).

As for claim 12, Ben shows “wherein said prohibiting is in further response to detecting a corresponding time for expiration has not yet expired, and wherein said method further comprises allowing the presenting of said presentation in response to detecting said time for expiration has expired” (page 27/sections 0323 & 0324 as the system can limit or prohibit the service or presentation to the client at a certain time period or per-service basis).

Regarding claims 13-16 and 20-21, these claims for “an interactive television system comprising: a remote proxy server configured to: receive one or more directives, wherein said directives are indicative of an audio, video and/or graphic presentation requiring a set of resources; determining from said directives that acquisition of a subset of said resources are a prerequisite to the presenting of said presentation; convey first signals which identify said subset of resources to a remote client device; and convey second signals which correspond to said directives; a client device configured to: receive said first signals; receive said second signals; and prohibit the presenting of said presentation until said subset of resources are acquired, in response to detecting said first signals” with same limitations as cited earlier are rejected for the reasons given in the scope of claims 1-7, and 11-12 as already discussed in details above.

Regarding claims 22 and 23, these claims for “a client device in an interactive television system, said device comprising: a receiver configured to receive signals corresponding to directives which are indicative of an audio, video and/or graphic presentation acquiring a set of resources; and a processing-unit-coupled-to-said-receiver, wherein said processing unit is configured to: determine from said directives that acquisition of a subset of said resources are a prerequisite to the presenting of said presentation; and prohibit the presenting of said presentation until said subset of resources are acquired” and “a carrier medium comprising program instructions executable to: receive directives which are indicative of an audio, video and/or graphic presentation requiring a set of resources; determine from said directives that a subset of said resources are a prerequisite to the presenting of said presentation; and prohibit the presenting of said presentation until said subset of resources are acquired” with same limitations

Art Unit: 2611

as cited earlier are rejected for the reasons given in the scope of claims 1-7 as already discussed in details above.

Claim Rejections - 35 USC 103

3. The following is a quotation of 35 U.S.C. 103(a) which forms the basis for all obviousness rejections set forth in this Office action:

(a) A patent may not be obtained though the invention is not identically disclosed or described as set forth in section 102 of this title, if the differences between the subject matter sought to be patented and the prior art are such that the subject matter as a whole would have been obvious at the time the invention was made to a person having ordinary skill in the art to which said subject matter pertains. Patentability shall not be negated by the manner in which the invention was made.

4. Claims 8-10 and 17-19 are rejected under 35 U.S.C. 103(a) as being unpatentable over Ben (U.S. Patent Pub No. US 2002/0010798 A1).

Regarding claims 8-10, Ben does not further mention “comprising enhancing a root entity in DTD to add a showstopper attribute indicative of prerequisite resources”; “comprising using a label within a Declarative Data Essence standard as an attribute to indicate a prerequisite resource”; and “comprising enhancing DVB-MHP by adding a showstopper AIT descriptor indicative of prerequisite resources”; however, the Examiner takes an official notice that these features are known in the art since these features are parts of the standard attributes for use within the HTML, and other scripting languages, i.e., DTD or Document Type Definition associated for use in Extensible Markup Language (XML). Therefore, it would have been obvious to one of ordinary skill in the art at the time the invention was made to modify Ben’s system with some known features as “DTD, Declarative Data Essence and enhancing DVB-

Art Unit: 2611

MHP by adding a showstopper AIT descriptor” in order to add or indicate a prerequisite resource(s) for identifying different resources in delivering contents to the client devices.

Conclusion

5. The prior art made of record and not relied upon is considered pertinent to applicant's disclosure.

Bradley et al (US Pub 2002/0194219 A1) and Lamkin et al (US Pub 2002/0088011 A1) disclose systems related to content deliveries and content attributes.

6. **Any response to this action should be mailed to:**

Commissioner of Patents and Trademarks

Washington, D.C. 20231

or faxed to: _____

(703) 872-9306, (for Technology Center 2600 only)

Hand-delivered responses should be brought to Crystal Park II, 2121 Crystal Drive, Arlington, VA, Sixth Floor (Receptionist).

7. Any inquiry concerning this communication or earlier communications from the examiner should be directed to Krista Kieu-Oanh Bui whose telephone number is (703) 305-0095. The examiner can normally be reached on Monday-Friday from 9:00 AM to 6:30 PM, with alternate Fridays off.

If attempts to reach the examiner by telephone are unsuccessful, the examiner's supervisor, Christopher Grant, can be reached on (703) 305-4755.

Art Unit: 2611

Any inquiry of a general nature or relating to the status of this application or proceeding should be directed to Technology Center 2600 Customer Service Office whose telephone number is (703) 306-0377.



**KRISTA BUI
PATENT EXAMINER**

Krista Bui
Art Unit 2611
October 5, 2004

Notice of References Cited	Application/Control No. 10/419,621	Applicant(s)/Patent Under Reexamination ALAIN DELPUCH ET AL.	
	Examiner KIEU-OANH T BUI	Art Unit 2611	Page 1 of 1

U.S. PATENT DOCUMENTS

*	Document Number Country Code-Number-Kind Code	Date MM-YYYY	Name	Classification
A	US-2002/0010798 A1	01-2002	Ben-Shaul et al.	709/247
B	US-2002/0194219 A1	12-2002	Bradley et al.	707/506
C	US-2002/0088011 A1	07-2002	Lamkin et al.	725/142
D	US-			
E	US-			
F	US-			
G	US-			
H	US-			
I	US-			
J	US-			
K	US-			
L	US-			
M	US-			

FOREIGN PATENT DOCUMENTS

*	Document Number Country Code-Number-Kind Code	Date MM-YYYY	Country	Name	Classification
N					
O					
P					
Q					
R					
S					
T					

NON-PATENT DOCUMENTS

*	Include as applicable: Author, Title Date, Publisher, Edition or Volume, Pertinent Pages)
U	
V	
W	
X	

*A copy of this reference is not being furnished with this Office action. (See MPEP § 707.05(a).)
Dates in MM-YYYY format are publication dates. Classifications may be US or foreign.

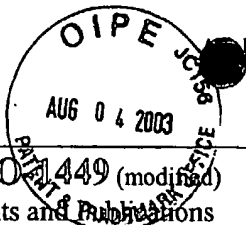

Form PTO 1449 (modified) List of Patents and Publications For Applicant's Information Disclosure Statement (Use several sheets if necessary)	ATTY. DKT. NO. 5266-06201 APPLICANT: Delpuch et al. FILING DATE: April 21, 2003	SERIAL NO. 10/419,621 GROUP: 2611
---	---	--

U.S. PATENT DOCUMENTS

EXAM. INITIALS	REF. DES.	DOCUMENT NUMBER	DATE	NAME	CLASS	SUB CLASS	FILING DATE APPROPRIATE
KB	A1	6,184,878	02/06/2001	Alonso et al.			

RECEIVED
AUG 06 2003
Technology Center 2600

FOREIGN PATENT DOCUMENTS

EXAM. INITIALS	REF. DES.	DOCUMENT NUMBER	DATE	COUNTRY	CLASS	SUB CLASS	TRANSLATIO YES/NO
KB	A2	WO 02/17639 A2	28/02/2002	PCT			
KB	A3	2 332 803	03/06/1999	GB			
KB	A4	0 839 599 A2	22/04/1998	EP			

OTHER ART (Including Author, Title, Date, Pertinent Pages, Etc.)

	A5	International Search Report; PCT/US 03/12241; Mailed 07/07/2003

EXAMINER: *R. Kuan* DATE CONSIDERED: 10/01/04

EXAMINER: Initial if citation considered, whether or not citation is in conformance with MPEP 609; Draw line through citation if not in conformance and not considered. Include copy of this form with next communication to the patent owner.

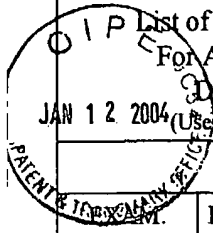

Form PTO-1449 (modified) List of Patents and Publications For Applicant's Information Disclosure Statement (Use several sheets if necessary)	ATTY. DKT. NO. 5266-06201 APPLICANT: Delpuch, et al. FILING DATE: April 21, 2003	SERIAL NO. 10/419,621 GROUP: 2611
---	--	--

U.S. PATENT DOCUMENTS

INITIALS	REF. DES.	DOCUMENT NUMBER	DATE	NAME	CLASS	SUB	FILING DATE APPROPRIATE
KB	B1	6,539,359	03/25/2003	Ladd, et al.			
KB	B2	6,415,303	07/02/2002	Meier, et al.			JAN 14 2004
KB	B3	6,188,401	02/13/2001	Peyer			Technology Center 2600
KB	B4	5,790,198	08/04/1998	Roop, et al.			

FOREIGN PATENT DOCUMENTS

EXAM. INITIALS	REF. DES.	DOCUMENT NUMBER	DATE	COUNTRY	CLASS	SUB CLASS	TRANSLATIO YES/NO

OTHER ART (Including Author, Title, Date, Pertinent Pages, Etc.)

KB	B5	"CSS3 Module: The Box Model"; W3C Working Draft, July 26, 2001; This version: http://www.w3.org/TR/2001/WD-css3-box-20010726 ; Latest version: http://www.w3.org/TR/css3-box ; Editor: Bert Bos; Copyright ©2001 W3C® (MIT, INRIA, Keio); Pages 1-104.

EXAMINER: *A. Kuan* DATE CONSIDERED: 10/01/04

EXAMINER: Initial if citation considered, whether or not citation is in conformance with MPEP 609; Draw line through citation if not in conformance and not considered. Include copy of this form with next communication to the patent owner.



ELECTRONIC INFORMATION DISCLOSURE STATEMENT

Electronic Version v18
Stylesheet Version v18.0

Title of Invention	Supporting Common Interactive Television Functionality Through Presentation Engine Syntax
-----------------------	--

Application Number: 10/419621 
Confirmation Number: 2305
First Named Applicant: Alain Delpuch
Attorney Docket Number: 5266-06201
Art Unit: 2611
Examiner: Kieu Oanh T Bui
Search string: (6345307).pn.

RECEIVED
JUL 01 2004
Technology Center 2600

Certification: This Information Disclosure Statement was submitted under the following conditions, which satisfies the requirement under 37 CFR 1.97(e). The filer certified:

That each item of information contained in the information disclosure statement was first cited in any communication from a foreign patent office in a counterpart foreign application not more than three months prior to the filing of the information disclosure statement.

US Patent Documents

Note: Applicant is not required to submit a paper copy of cited US Patent Documents

init	Cite.No.	Patent No.	Date	Patentee	Kind	Class	Subclass
KB	1	6345307	2002-02-05	Booth			

Signature

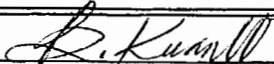
Examiner Name	Date
	10/01/04



ELECTRONIC INFORMATION DISCLOSURE STATEMENT

Electronic Version v18
Stylesheet Version v18.0

Title of Invention	Supporting Common Interactive Television Functionality Through Presentation Engine Syntax
-----------------------	--

Application Number: 10/419621 

Confirmation Number: 2305

First Named Applicant: Alain Delpuch

Attorney Docket Number: 5266-06201

Art Unit: 2611

Examiner: Kieu Oanh T Bui

Search string: (6345307).pn.

RECEIVED
JUL 01 2004
Technology Center 2600

Certification: This Information Disclosure Statement was submitted under the following conditions, which satisfies the requirement under 37 CFR 1.97(e). The filer certified:

That each item of information contained in the information disclosure statement was first cited in any communication from a foreign patent office in a counterpart foreign application not more than three months prior to the filing of the information disclosure statement.

US Patent Documents

Note: Applicant is not required to submit a paper copy of cited US Patent Documents

init	Cite.No.	Patent No.	Date	Patentee	Kind	Class	Subclass
KB	1	6345307	2002-02-05	Booth			

Signature

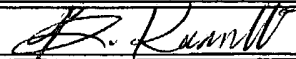
Examiner Name	Date
	10/01/04



UNITED STATES PATENT AND TRADEMARK OFFICE

UNITED STATES DEPARTMENT OF COMMERCE
 United States Patent and Trademark Office
 Address: COMMISSIONER FOR PATENTS
 P.O. Box 1450
 Alexandria, Virginia 22313-1450
 www.uspto.gov

BIBDATASHEET

CONFIRMATION NO. 2305

Bib Data Sheet

SERIAL NUMBER 10/419,621	FILING DATE 04/21/2003 RULE 1.47	CLASS 725	GROUP ART UNIT 2611	ATTORNEY DOCKET NO. 5266-06201
-----------------------------	--	--------------	------------------------	-----------------------------------

APPLICANTS

Alain Delpuch, Les Essarts Le Roi, FRANCE;

James Whittedge, Naperville, IL;
 Jean-Rene Menand, Los Altos, CA; Emmanuel Barbier, Paris, FRANCE;
 Kevin Hausman, Naperville, IL;
 Debra Hensgen, Redwood City, CA;
 Dongmin Su, Santa Clara, CA;

** CONTINUING DATA ***** ^{KB} *YES*
 This appln claims benefit of 60/373,883 04/19/2002

** FOREIGN APPLICATIONS ***** ^{KB} *NONE*

IF REQUIRED, FOREIGN FILING LICENSE GRANTED _____
 ** 06/17/2003

Foreign Priority claimed <input type="checkbox"/> yes <input checked="" type="checkbox"/> no	STATE OR	SHEETS	TOTAL	INDEPENDENT
35 USC 119 (a-d) conditions met <input type="checkbox"/> yes <input checked="" type="checkbox"/> no <input type="checkbox"/> Met after Allowance	COUNTRY	DRAWING	CLAIMS	CLAIMS
Verified and Acknowledged <i>B. Kumil</i> Examiner's Signature <i>KB</i> Initials	FRANCE	5	23	4

ADDRESS
 44015
 OPTV/MEYERTONS
 THE CHASE BUILDING
 700 LAVACA, SUITE 800
 AUSTIN , TX
 78701

TITLE
 Supporting common interactive television functionality through presentation engine syntax

All Fees

FILING FEE RECEIVED 1018	FEES: Authority has been given in Paper No. _____ to charge/credit DEPOSIT ACCOUNT No. _____ for following:	<input type="checkbox"/> 1.16 Fees (Filing) <input type="checkbox"/> 1.17 Fees (Processing Ext. of time) <input type="checkbox"/> 1.18 Fees (Issue) <input type="checkbox"/> Other _____ <input type="checkbox"/> Credit
------------------------------------	---	--

Index of Claims



Application No.

10/419,621

Examiner

KIEU-OANH T BUI

Applicant(s)

ALAIN DELPUCH ET AL.

Art Unit

2611

√	Rejected
=	Allowed

—	(Through numeral) Cancelled
÷	Restricted

N	Non-Elected
I	Interference

A	Appeal
O	Objected

Claim		Date			
Final	Original				
	1				
	2				
	3				
	4				
	5				
	6				
	7				
	8				
	9				
	10				
	11				
	12				
	13				
	14				
	15				
	16				
	17				
	18				
	19				
	20				
	21				
	22				
	23				
	24				
	25				
	26				
	27				
	28				
	29				
	30				
	31				
	32				
	33				
	34				
	35				
	36				
	37				
	38				
	39				
	40				
	41				
	42				
	43				
	44				
	45				
	46				
	47				
	48				
	49				
	50				

Claim		Date			
Final	Original				
	51				
	52				
	53				
	54				
	55				
	56				
	57				
	58				
	59				
	60				
	61				
	62				
	63				
	64				
	65				
	66				
	67				
	68				
	69				
	70				
	71				
	72				
	73				
	74				
	75				
	76				
	77				
	78				
	79				
	80				
	81				
	82				
	83				
	84				
	85				
	86				
	87				
	88				
	89				
	90				
	91				
	92				
	93				
	94				
	95				
	96				
	97				
	98				
	99				
	100				

Claim		Date			
Final	Original				
	101				
	102				
	103				
	104				
	105				
	106				
	107				
	108				
	109				
	110				
	111				
	112				
	113				
	114				
	115				
	116				
	117				
	118				
	119				
	120				
	121				
	122				
	123				
	124				
	125				
	126				
	127				
	128				
	129				
	130				
	131				
	132				
	133				
	134				
	135				
	136				
	137				
	138				
	139				
	140				
	141				
	142				
	143				
	144				
	145				
	146				
	147				
	148				
	149				
	150				

Search Notes



Application No.

10/419,621

Examiner

KIEU-OANH T BUI

Applicant(s)

ALAIN DELPUCH ET AL.

Art Unit

2611

SEARCHED

Class	Subclass	Date	Examiner
725	105, 109, 112, 114, 117, 135	09/23/07	KB
709	217, 223, 225, 226, 231		
710	48, 266		

**SEARCH NOTES
(INCLUDING SEARCH STRATEGY)**

Consulted;	DATE	EXMR
Fast search: 725 & Text 709; 710	09/23/07	KB

INTERFERENCE SEARCHED

Class	Subclass	Date	Examiner



APPLICATION NUMBER	PATENT NUMBER	GROUP ART UNIT	FILE WRAPPER LOCATION
10/419,621		2611	21M1

Change of Address/Power of Attorney

The following fields have been set to Customer Number 44015 on

- Correspondence Address
- Power of Attorney

The address of record for Customer Number 44015 is:

OPTV/MEYERTONS
THE CHASE BUILDING
700 LAVACA, SUITE 800
AUSTIN, TX 78701

The Practitioners of record for Customer Number 44015 are:

PTO INSTRUCTIONS:

Please take the following action when the correspondence address has been changed to a customer number:

- 1) Add 'ADDRESS CHANGE TO CUSTOMER NUMBER' on the next available content line of the File Jacket.
- 2) Put a line through the old address on the File Jacket and enter the Customer Number as the new address.
- 3) File this Notice in the File Jacket.

Please take the following action when the correspondence address has NOT been changed:

- 1) File this Notice in the File Jacket

IN THE CLAIMS

Please amend claims 1-4, 13-14, and 21-22 as indicated below.

1. (Currently Amended) A method comprising:
receiving one or more directives, wherein said directives are indicative of an audio, video and/or graphic presentation which requires ~~requiring~~ a set of resources;
determining whether said one or more directives includes a prerequisite directive which indicates that acquisition of a subset of said set of resources is a prerequisite for initiating the presentation;
~~determining from said directives that acquisition of a subset of said resources are a prerequisite to the presenting of said presentation; and~~
initiating said presentation, in response to determining the one or more directives do not include said prerequisite directive; and
prohibiting ~~the presenting~~ initiation of said presentation until said subset of resources are acquired, in response to determining the one or more directives include said prerequisite directive.

2. (Currently Amended) The method of claim 1, wherein said ~~subset of resources are indicated using~~ prerequisite directive comprises one or more directives selected from the group consisting of: a markup language, a scripting language, and a style sheet.

3. (Currently Amended) The method of claim 2, wherein said one or more directives are received by a proxy server in an interactive television system.

4. (Currently Amended) The method of claim 3, wherein said determining is performed by said proxy server, and wherein said method further comprises said proxy server conveying signals ~~which correspond to~~ indicative of said subset of resources to a remote client device.

5. (Original) The method of claim 4, further comprising said client device acquiring said subset of resources in response to detecting said signals.
6. (Original) The method of claim 5, wherein said subset comprises streaming audio and/or video, and wherein acquisition of the streaming audio and/or video comprises configuring hardware resources within said client device.
7. (Original) The method of claim 5, wherein acquisition of the subset of resources comprises the client device initiating requests for remotely located resources to be conveyed to said client device.
8. (Original) The method of claim 1, further comprising enhancing a root entity in DTD to add a showstopper attribute indicative of prerequisite resources.
9. (Original) The method of claim 1, further comprising using a label within a Declarative Data Essence standard as an attribute to indicate a prerequisite resource.
10. (Original) The method of claim 1, further comprising enhancing DVB-MHP by adding a showstopper AIT descriptor indicative of prerequisite resources.
11. (Original) The method of claim 1, further comprising defining a META name/value pair, wherein said name is indicative that said corresponding value is a prerequisite resource.
12. (Original) The method of claim 1, wherein said prohibiting is in further response to detecting a corresponding time for expiration has not yet expired, and wherein said method further comprises allowing the presenting of said presentation in response to detecting said time for expiration has expired.

13. (Currently Amended) An interactive television system comprising:

a remote proxy server configured to:

receive one or more directives, wherein said directives are indicative of an audio, video and/or graphic presentation which requires ~~requiring~~ a set of resources;

determine whether said one or more directives includes a prerequisite directive which indicates that acquisition of a subset of said set of resources is a prerequisite for initiating the presentation;

~~determine from said directives that acquisition of a subset of said resources are a prerequisite to the presenting of said presentation;~~

convey first signals which identify said subset of resources to a remote client device, in response to determining the one or more directives include said prerequisite directive; and

convey second signals which correspond to said one or more directives.

a client device configured to:

receive said first signals;

receive said second signals; and

prohibit ~~the presenting~~ initiation of said presentation until said subset of resources are acquired, in response to detecting said first signals.

14. (Currently Amended) The system of claim 13, wherein said ~~subset of resources are indicated using~~ prerequisite directive comprises one or more directives selected from the group consisting of: a markup language, a scripting language, and a style sheet.

15. (Original) The system of claim 14, wherein acquiring said subset of resources comprises said client device configuring hardware resources within said client device.

16. (Original) The system of claim 14, wherein acquiring said subset of resources comprises initiating requests for remotely located resources to be conveyed to said client device.
17. (Original) The system of claim 13, further comprising enhancing a root entity in DTD by adding a showstopper attribute indicative of prerequisite resources.
18. (Original) The system of claim 13, wherein said directives include the use of a showstopper attribute indicative of prerequisite resources.
19. (Original) The system of claim 13, wherein said server is configured to detect a DVB-MHP showstopper AIT descriptor indicative of prerequisite resources.
20. (Original) The system of claim 13, wherein said directives define a META name/value pair, wherein said name is indicative that said corresponding value is a prerequisite resource.
21. (Currently Amended) The system of claim 13, wherein said device is configured to prohibit said ~~presenting~~ initiation in further response to detecting a corresponding time for expiration has not yet expired, and wherein said device is further configured to allow the presenting of said presentation in response to detecting said time for expiration has expired.
22. (Currently Amended) A client device in an interactive television system, said device comprising:
 - a receiver configured to receive signals corresponding to directives which are indicative of an audio, video and/or graphic presentation requiring a set of resources; and
 - a processing unit coupled to said receiver, wherein said processing unit is configured to:

determine whether said one or more directives includes a prerequisite directive which indicates that acquisition of a subset of said set of resources is a prerequisite for initiating the presentation;
~~determine from said directives that acquisition of a subset of said resources are a prerequisite to the presenting of said presentation;~~
and
initiate said presentation, in response to determining the one or more directives do not include said prerequisite directive; and
prohibit ~~the presenting~~ initiation of said presentation until said subset of resources are acquired, in response to determining the one or more directives include said prerequisite directive.

23. (Currently Amended) A carrier medium comprising program instructions executable to:
receive directives which are indicative of an audio, video and/or graphic presentation ~~requiring~~ which requires a set of resources;
determine whether said one or more directives includes a prerequisite directive which indicates that acquisition of a subset of said set of resources is a prerequisite for the presentation;
~~determine from said directives that a subset of said resources are a prerequisite to the presenting of said presentation;~~ and
initiate said presentation, in response to determining the one or more directives do not include said prerequisite directive; and
prohibit the presenting of said presentation until said subset of resources are acquired, in response to determining the one or more directives include said prerequisite directive.

REMARKS

Claims 1-23 were pending prior to the current amendment. Claims 1-4, 13-14, and 21-22 have been amended to further clarify the nature of the claimed invention. Accordingly, claims 1-23 remain pending.

In the present Office Action, claims 1-7, 11-16, and 20-23 stand rejected under 35 U.S.C. § 102(e) as being anticipated by U.S. Patent Publication No. 2002/0010798 A1 (hereinafter "Ben"). In addition, claims 8-10 and 17-19 stand rejected under 35 U.S.C. § 103(a) as being unpatentable over Ben. Applicant respectfully traverses the above rejections and requests reconsideration in view of the following discussion.

In order for there to be anticipation, each and every element of the claimed invention must be present in a single prior reference. However, Applicant submits that each of the pending claims recite elements which are not taught, suggested, or implied by Ben. In the present case, each of independent claims 1, 13, 22, and 23 stand rejected as being anticipated by Ben. For example, paragraph 2 of the Office Action suggests Ben discloses all of the features of claim 1. However, Applicant submits Ben does not disclose all of the features of claim 1: For example, claim 1, as amended, recites a method which includes:

“receiving one or more directives, wherein said directives are indicative of an audio, video and/or graphic presentation which requires a set of resources;
determining whether said one or more directives includes a prerequisite directive which indicates that acquisition of a subset of said set of resources is a prerequisite for initiating the presentation;
initiating said presentation, in response to determining the one or more directives do not include said prerequisite directive; and
prohibiting initiation of said presentation until said subset of resources are acquired, in response to determining the one or more directives include said prerequisite directive.” (emphasis added).

Applicant submits at least the above highlighted features are neither taught nor suggested by Ben. With respect to claim 1, a number of portions of Ben are cited as disclosing the above features. For example, paragraphs 27, 51, 221, 231, 256, and 263 of Ben are cited. However, these portions of Ben merely describe the delivery of content to end customers and describe the ability to create server profiles. In addition, paragraphs 431 and 432 of Ben (reproduced below) are cited as being related to directives.

“Referring now to FIG. 12, the operation of the directives editor 122 of the front edge tool is now disclosed in further detail. The directives editor 122 is a graphical editor for generating service profiles. It is an important aspect of the invention that the directives editor 122 enables content providers to define advanced services on the edges of the internet. That is, providers can control what content is viewable by different users at different regions, and how content is delivered to different users/regions in terms of latency, reliability and overall quality of delivery.

As seen in FIG. 17 the directives editor 122 reads and writes data from a database 180, using the facilities of the database manager 182. The database manager 182 preferably uses the SQL protocol for sending and retrieving data from the database 180. It should be noted that the database manager 182 is the only element of the system having a direct connection to the database 180. An XML manager 184 is responsible for generating XML files based on the database 180 for use by the edge server 48 and the edge servers 120 (FIG. 6). Another important component is the import-export facility 186 that can export profiles from the database 180 to XML files, and can import profiles from XML files to the database 180.” (Ben, paras. 431-432).

However, as can be seen from the above, the directives editor of Ben is a tool for generating service profiles and is not directly related to Applicant’s claimed directives which are indicative of “an audio, video and/or graphic presentation which requires a set of resources.”

Finally, paragraphs 314-324 of Ben are cited as disclosing the recited features regarding “prohibiting initiation of said presentation until said subset of resources are acquired.” More particularly, the examiner states that Ben discloses a service may be either authorized or denied depending upon whether required billing directives are

acquired. Applicant first notes that Ben nowhere discloses or makes any reference to billing directives. The only reference to billing in Ben is in paragraph 329 wherein it merely states that “[a]n interface to external billing software is provided, in order to provide billing services.” However, even if Ben did disclose such a billing directive, such a directive would merely serve to allow or deny access to a presentation and would not be equivalent to the features recited in claim 1. In any event, Applicant submits that Ben nowhere includes any disclosure related to the recited “determining”, “prerequisite directive”, or “subset of said resources”. Further, Ben nowhere discloses initiating or prohibiting as recited. Therefore, claim 1 is patentably distinguished from the cited art. As each of independent claims 13, 22, and 23 include similar features, each of these claims are similarly distinguished. In addition, as Ben does not disclose or suggest a prerequisite directive, the features of claims 2 and 14 which are directed to a prerequisite directive are not disclosed by Ben.

In addition to the above, the additional features of claim 6 are neither taught nor suggested by the cited art. Claim 6 recites “said subset comprises streaming audio and/or video, and wherein acquisition of the streaming audio and/or video comprises configuring hardware resources within said client device.” As claim 6 depends upon the prior claims, “said subset” is a direct reference to the subset recited in claim 1. As already discussed, the recited prerequisite directive indicates acquisition of this subset (which comprises streaming audio and/or video) is a prerequisite for initiating the presentation. In the discussion of claim 1, the office action made the suggestion that a “billing directive” represented the resources which have not been acquired. Applicant has already discussed the absence of disclosure of such a billing directive in Ben. However, Applicant further notes that Ben nowhere teaches or suggests the subset of resources comprise streaming audio and/or video as recited in the claims.

With respect to dependent claims 11 and 20, the present office action suggests that Ben discloses “defining a META name/value pair, wherein said name is indicative that said corresponding value is a prerequisite resource.” In particular, reference is made to paragraph 192 of Ben wherein it states:

“The special content delivery markup language, CDML, is provided in preferred embodiments of the invention in order to assure highly controlled content delivery characteristics. CDML enables content providers to define precisely, and in as much detail as desired, how content is delivered to its destinations. It also enables the content provider to supply descriptive and classification information about its content so that local delivery directives, as seen at the edge, can identify the content to be delivered. As described above, CDML code is generated by graphical editors, and is interpreted by two entities. Referring again to FIG. 6, the source interpreter 52 at the origin controls how CDML meta-information is disseminated to the edges of the internet, and the target interpreter 56 implements the semantics of the CDML code at the edges. In addition, the source interpreter 52 and the target interpreter 56 cooperate to carry out distributed policies that require both interpreters, such as mirroring content from the origin server to some of the edges as well as pack and unpack operations.”

However, the above excerpt from Ben makes no reference to “defining a META name/value pair, wherein said name is indicative that said corresponding value is a prerequisite resource.” Rather, passing reference is made to “meta-information” which is in no way equivalent to the recited features of claims 11 and 20.

In view of the above, Applicant submits each of the pending claims are patentably distinguishable from the cited art and all claims are believed in condition for allowance.

CONCLUSION

Applicant submits the application is in condition for allowance, and an early notice to that effect is requested.

If any extensions of time (under 37 C.F.R. § 1.136) are necessary to prevent the above referenced application(s) from becoming abandoned, Applicant(s) hereby petition for such extensions. If any fees are due, the Commissioner is authorized to charge said fees to Meyertons, Hood, Kivlin, Kowert, & Goetzel, P.C. Deposit Account No. 501505/5266-06201/RDR.

Respectfully submitted,

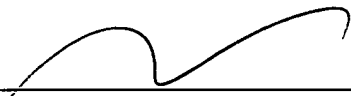

Rory D. Rankin
Reg. No. 47,884
ATTORNEY FOR APPLICANT(S)

Meyertons, Hood, Kivlin,
Kowert, & Goetzel, P.C.
P.O. Box 398
Austin, TX 78767-0398
Phone: (512) 853-8800

Date: January 18, 2005

PATENT APPLICATION FEE DETERMINATION RECORD
Effective December 8, 2004

10/49621

CLAIMS AS FILED - PART I

	(Column 1)	(Column 2)
TOTAL CLAIMS		
FOR	NUMBER FILED	NUMBER EXTRA
TOTAL CHARGEABLE CLAIMS	minus 20= *	
INDEPENDENT CLAIMS	minus 3 = *	
MULTIPLE DEPENDENT CLAIM PRESENT <input type="checkbox"/>		

* If the difference in column 1 is less than zero, enter "0" in column 2

SMALL ENTITY TYPE

OR OTHER THAN SMALL ENTITY

SMALL ENTITY TYPE			OTHER THAN SMALL ENTITY	
RATE	FEE		RATE	FEE
BASIC FEE	150.00	OR	BASIC FEE	300.00
X\$ 25=		OR	X\$50=	
X100=		OR	X200=	
+180=		OR	+360=	
TOTAL		OR	TOTAL	

CLAIMS AS AMENDED - PART II

	(Column 1)		(Column 2)		(Column 3)
AMENDMENT A	1-21-05	CLAIMS REMAINING AFTER AMENDMENT		HIGHEST NUMBER PREVIOUSLY PAID FOR	PRESENT EXTRA
	Total	* 23	Minus	** 23	= /
	Independent	* 4	Minus	*** 4	= /
FIRST PRESENTATION OF MULTIPLE DEPENDENT CLAIM <input type="checkbox"/>					

SMALL ENTITY OR

OTHER THAN SMALL ENTITY

SMALL ENTITY			OTHER THAN SMALL ENTITY	
RATE	ADDITIONAL FEE		RATE	ADDITIONAL FEE
X\$ 25=		OR	X\$50=	
X100=		OR	X200=	
+180=		OR	+360=	
TOTAL ADDIT. FEE		OR	TOTAL ADDIT. FEE	

	(Column 1)		(Column 2)		(Column 3)
AMENDMENT B		CLAIMS REMAINING AFTER AMENDMENT		HIGHEST NUMBER PREVIOUSLY PAID FOR	PRESENT EXTRA
	Total	*	Minus	**	=
	Independent	*	Minus	***	=
FIRST PRESENTATION OF MULTIPLE DEPENDENT CLAIM <input type="checkbox"/>					

SMALL ENTITY			OTHER THAN SMALL ENTITY	
RATE	ADDITIONAL FEE		RATE	ADDITIONAL FEE
X\$ 25=		OR	X\$50=	
X100=		OR	X200=	
+180=		OR	+360=	
TOTAL ADDIT. FEE		OR	TOTAL ADDIT. FEE	

	(Column 1)		(Column 2)		(Column 3)
AMENDMENT C		CLAIMS REMAINING AFTER AMENDMENT		HIGHEST NUMBER PREVIOUSLY PAID FOR	PRESENT EXTRA
	Total	*	Minus	**	=
	Independent	*	Minus	***	=
FIRST PRESENTATION OF MULTIPLE DEPENDENT CLAIM <input type="checkbox"/>					

SMALL ENTITY			OTHER THAN SMALL ENTITY	
RATE	ADDITIONAL FEE		RATE	ADDITIONAL FEE
X\$ 25=		OR	X\$50=	
X100=		OR	X200=	
+180=		OR	+360=	

Ref #	Hits	Search Query	DBs	Default Operator	Plurals	Time Stamp
L1	2742	"proxy server" and HTML	US-PGPUB; USPAT; EPO	OR	ON	2005/06/06 16:30
L2	1651	L1 and "markup language"	US-PGPUB; USPAT; EPO	OR	ON	2005/06/06 16:30
L3	175	L2 and "scripting language"	US-PGPUB; USPAT; EPO	OR	ON	2005/06/06 16:30
L4	130	L3 and interactive	US-PGPUB; USPAT; EPO	OR	ON	2005/06/06 16:30
L5	91	L4 and (TV or television)	US-PGPUB; USPAT; EPO	OR	ON	2005/06/06 16:30
L6	64	L5 and META	US-PGPUB; USPAT; EPO	OR	ON	2005/06/06 16:30
L7	35	L6 and "style sheet"	US-PGPUB; USPAT; EPO	OR	ON	2005/06/06 16:30
L8	35	L7 and (subset or resource)	US-PGPUB; USPAT; EPO	OR	ON	2005/06/06 16:30
L9	33	L8 and (video and audio and graphics)	US-PGPUB; USPAT; EPO	OR	ON	2005/06/06 16:30
L10	33	L9 and (client or user)	US-PGPUB; USPAT; EPO	OR	ON	2005/06/06 16:30
L11	33	L10 and DTD	US-PGPUB; USPAT; EPO	OR	ON	2005/06/06 16:30
L12	32	L11 and (television near3 content)	US-PGPUB; USPAT; EPO	OR	ON	2005/06/06 16:30
L13	30	L12 and (attribute or directive)	USPAT	OR	ON	2005/06/06 16:30
L14	0	L13 and "prerequisite directive"	US-PGPUB; USPAT; EPO	OR	ON	2005/06/06 16:31
L15	1	"725"/\$.ccls. and "prerequisite directive"	US-PGPUB; USPAT; EPO	OR	ON	2005/06/06 16:32
L16	0	"348"/\$.ccls. and "prerequisite directive"	US-PGPUB; USPAT; EPO	OR	ON	2005/06/06 16:32

L17	0	"370"/\$.cls. and "prerequisite directive"	US-PGPUB; USPAT; EPO	OR	ON	2005/06/06 16:32
L18	0	"709"/\$.cls. and "prerequisite directive"	US-PGPUB; USPAT; EPO	OR	ON	2005/06/06 16:33
L19	1	"prerequisite directive"	US-PGPUB; USPAT; EPO	OR	ON	2005/06/06 16:33
S1	8391	"725"/\$.cls.	US-PGPUB; USPAT; EPO	OR	ON	2004/09/23 17:45
S2	912	S1 and HTML	US-PGPUB; USPAT; EPO	OR	ON	2004/09/23 17:47
S3	475	S2 and "markup language"	US-PGPUB; USPAT; EPO	OR	ON	2004/09/23 18:06
S4	24	S3 and "scripting language"	US-PGPUB; USPAT; EPO	OR	ON	2004/09/23 18:06
S5	2	S4 and "proxy server"	US-PGPUB; USPAT; EPO	OR	ON	2004/09/23 17:46
S6	2314	"proxy server" and HTML	US-PGPUB; USPAT; EPO	OR	ON	2004/09/23 17:48
S7	1412	S6 and "markup language"	US-PGPUB; USPAT; EPO	OR	ON	2004/09/23 17:48
S8	157	S7 and "scripting language"	US-PGPUB; USPAT; EPO	OR	ON	2004/09/23 17:49
S9	118	S8 and interactive	US-PGPUB; USPAT; EPO	OR	ON	2004/09/23 17:49
S10	80	S9 and (TV or television)	US-PGPUB; USPAT; EPO	OR	ON	2004/09/23 17:50
S11	59	S10 and META	US-PGPUB; USPAT; EPO	OR	ON	2004/09/23 17:51
S12	1	S11 and "DVB-MHP"	US-PGPUB; USPAT; EPO	OR	ON	2004/09/23 17:51
S13	34	S11 and "style sheet"	US-PGPUB; USPAT; EPO	OR	ON	2004/09/23 18:06

S14	2	S13 and (time near8 expiration)	US-PGPUB; USPAT; EPO	OR	ON	2004/09/23 17:54
S15	34	S13 and (subset or resource)	US-PGPUB; USPAT; EPO	OR	ON	2004/09/23 17:55
S16	32	S15 and (video and audio and graphics)	US-PGPUB; USPAT; EPO	OR	ON	2004/09/23 17:55
S17	32	S16 and (client or user)	US-PGPUB; USPAT; EPO	OR	ON	2004/09/23 17:56
S18	1	S17 and AIT	US-PGPUB; USPAT; EPO	OR	ON	2004/09/23 17:57
S19	32	S17 and DTD	US-PGPUB; USPAT; EPO	OR	ON	2004/09/23 17:57
S20	31	S19 and (television near3 content)	US-PGPUB; USPAT; EPO	OR	ON	2004/09/23 17:57
S21	31	S20 and (attribute or directive)	US-PGPUB; USPAT; EPO	OR	ON	2004/09/23 17:59
S22	1	S21 and ("declarative data essence" or DDE)	US-PGPUB; USPAT; EPO	OR	ON	2004/09/23 17:59
S23	29	S20 and (attribute or directive)	USPAT	OR	ON	2005/06/06 16:30
S24	0	S23 and "META name"	US-PGPUB; USPAT; EPO	OR	ON	2004/09/23 18:00
S25	0	S23 and (META near3 name)	US-PGPUB; USPAT; EPO	OR	ON	2004/09/23 18:00
S26	0	S23 and (resource near8 requirement)	US-PGPUB; USPAT; EPO	OR	ON	2004/09/23 18:01
S27	29	S23 and (web or internet or WWW)	US-PGPUB; USPAT; EPO	OR	ON	2004/09/23 18:02
S28	29	S27 and (detect\$ and prohibit\$3)	US-PGPUB; USPAT; EPO	OR	ON	2004/09/23 18:05
S29	1	S1 and S17	US-PGPUB; USPAT; EPO	OR	ON	2004/09/23 18:05
S30	573	S1 and "markup language"	US-PGPUB; USPAT; EPO	OR	ON	2004/09/23 18:06

S31	26	S30 and "scripting language"	US-PGPUB; USPAT; EPO	OR	ON	2004/09/23 18:06
S32	4	S31 and "style sheet"	US-PGPUB; USPAT; EPO	OR	ON	2004/09/23 18:06



UNITED STATES PATENT AND TRADEMARK OFFICE

UNITED STATES DEPARTMENT OF COMMERCE
United States Patent and Trademark Office
Address: COMMISSIONER FOR PATENTS
P.O. Box 1450
Alexandria, Virginia 22313-1450
www.uspto.gov

NOTICE OF ALLOWANCE AND FEE(S) DUE

44015 7590 06/29/2005
OPTV/MEYERTONS
THE CHASE BUILDING
700 LAVACA, SUITE 800
AUSTIN, TX 78701

EXAMINER

BUI, KIEU OANH T

ART UNIT PAPER NUMBER

2611

DATE MAILED: 06/29/2005

Table with 5 columns: APPLICATION NO., FILING DATE, FIRST NAMED INVENTOR, ATTORNEY DOCKET NO., CONFIRMATION NO.
10/419,621 04/21/2003 Alain Delpuch 5266-06201 2305

TITLE OF INVENTION: SUPPORTING COMMON INTERACTIVE TELEVISION FUNCTIONALITY THROUGH PRESENTATION ENGINE SYNTAX

Table with 6 columns: APPLN. TYPE, SMALL ENTITY, ISSUE FEE, PUBLICATION FEE, TOTAL FEE(S) DUE, DATE DUE
nonprovisional NO \$1400 \$300 \$1700 09/29/2005

THE APPLICATION IDENTIFIED ABOVE HAS BEEN EXAMINED AND IS ALLOWED FOR ISSUANCE AS A PATENT. PROSECUTION ON THE MERITS IS CLOSED. THIS NOTICE OF ALLOWANCE IS NOT A GRANT OF PATENT RIGHTS. THIS APPLICATION IS SUBJECT TO WITHDRAWAL FROM ISSUE AT THE INITIATIVE OF THE OFFICE OR UPON PETITION BY THE APPLICANT. SEE 37 CFR 1.313 AND MPEP 1308.

THE ISSUE FEE AND PUBLICATION FEE (IF REQUIRED) MUST BE PAID WITHIN THREE MONTHS FROM THE MAILING DATE OF THIS NOTICE OR THIS APPLICATION SHALL BE REGARDED AS ABANDONED. THIS STATUTORY PERIOD CANNOT BE EXTENDED. SEE 35 U.S.C. 151. THE ISSUE FEE DUE INDICATED ABOVE REFLECTS A CREDIT FOR ANY PREVIOUSLY PAID ISSUE FEE APPLIED IN THIS APPLICATION. THE PTOL-85B (OR AN EQUIVALENT) MUST BE RETURNED WITHIN THIS PERIOD EVEN IF NO FEE IS DUE OR THE APPLICATION WILL BE REGARDED AS ABANDONED.

HOW TO REPLY TO THIS NOTICE:

I. Review the SMALL ENTITY status shown above.

If the SMALL ENTITY is shown as YES, verify your current SMALL ENTITY status:

- A. If the status is the same, pay the TOTAL FEE(S) DUE shown above.
B. If the status above is to be removed, check box 5b on Part B - Fee(s) Transmittal and pay the PUBLICATION FEE (if required) and twice the amount of the ISSUE FEE shown above, or

If the SMALL ENTITY is shown as NO:

- A. Pay TOTAL FEE(S) DUE shown above, or
B. If applicant claimed SMALL ENTITY status before, or is now claiming SMALL ENTITY status, check box 5a on Part B - Fee(s) Transmittal and pay the PUBLICATION FEE (if required) and 1/2 the ISSUE FEE shown above.

II. PART B - FEE(S) TRANSMITTAL should be completed and returned to the United States Patent and Trademark Office (USPTO) with your ISSUE FEE and PUBLICATION FEE (if required). Even if the fee(s) have already been paid, Part B - Fee(s) Transmittal should be completed and returned. If you are charging the fee(s) to your deposit account, section "4b" of Part B - Fee(s) Transmittal should be completed and an extra copy of the form should be submitted.

III. All communications regarding this application must give the application number. Please direct all communications prior to issuance to Mail Stop ISSUE FEE unless advised to the contrary.

IMPORTANT REMINDER: Utility patents issuing on applications filed on or after Dec. 12, 1980 may require payment of maintenance fees. It is patentee's responsibility to ensure timely payment of maintenance fees when due.

PART B - FEE(S) TRANSMITTAL

Complete and send this form, together with applicable fee(s), to: **Mail** **Mail Stop ISSUE FEE**
Commissioner for Patents
P.O. Box 1450
Alexandria, Virginia 22313-1450
or Fax (703) 746-4000

INSTRUCTIONS: This form should be used for transmitting the ISSUE FEE and PUBLICATION FEE (if required). Blocks 1 through 5 should be completed where appropriate. All further correspondence including the Patent, advance orders and notification of maintenance fees will be mailed to the current correspondence address as indicated unless corrected below or directed otherwise in Block 1, by (a) specifying a new correspondence address; and/or (b) indicating a separate "FEE ADDRESS" for maintenance fee notifications.

CURRENT CORRESPONDENCE ADDRESS (Note: Use Block 1 for any change of address)

44015 7590 06/29/2005
OPTV/MEYERTONS
THE CHASE BUILDING
700 LAVACA, SUITE 800
AUSTIN, TX 78701

Note: A certificate of mailing can only be used for domestic mailings of the Fee(s) Transmittal. This certificate cannot be used for any other accompanying papers. Each additional paper, such as an assignment or formal drawing, must have its own certificate of mailing or transmission.

Certificate of Mailing or Transmission
 I hereby certify that this Fee(s) Transmittal is being deposited with the United States Postal Service with sufficient postage for first class mail in an envelope addressed to the Mail Stop ISSUE FEE address above, or being facsimile transmitted to the USPTO (703) 746-4000, on the date indicated below.

(Depositor's name)
(Signature)
(Date)

APPLICATION NO.	FILING DATE	FIRST NAMED INVENTOR	ATTORNEY DOCKET NO.	CONFIRMATION NO.
10/419,621	04/21/2003	Alain Delpuch	5266-06201	2305

TITLE OF INVENTION: SUPPORTING COMMON INTERACTIVE TELEVISION FUNCTIONALITY THROUGH PRESENTATION ENGINE SYNTAX

APPLN. TYPE	SMALL ENTITY	ISSUE FEE	PUBLICATION FEE	TOTAL FEE(S) DUE	DATE DUE
nonprovisional	NO	\$1400	\$300	\$1700	09/29/2005

EXAMINER	ART UNIT	CLASS-SUBCLASS
BUI, KIEU OANH T	2611	725-093000

<p>1. Change of correspondence address or indication of "Fee Address" (37 CFR 1.363).</p> <p><input type="checkbox"/> Change of correspondence address (or Change of Correspondence Address form PTO/SB/122) attached.</p> <p><input type="checkbox"/> "Fee Address" indication (or "Fee Address" Indication form PTO/SB/47; Rev 03-02 or more recent) attached. Use of a Customer Number is required.</p>	<p>2. For printing on the patent front page, list</p> <p>(1) the names of up to 3 registered patent attorneys or agents OR, alternatively, _____ 1</p> <p>(2) the name of a single firm (having as a member a registered attorney or agent) and the names of up to 2 registered patent attorneys or agents. If no name is listed, no name will be printed. _____ 2</p> <p>_____ 3</p>
--	---

3. ASSIGNEE NAME AND RESIDENCE DATA TO BE PRINTED ON THE PATENT (print or type)

PLEASE NOTE: Unless an assignee is identified below, no assignee data will appear on the patent. If an assignee is identified below, the document has been filed for recordation as set forth in 37 CFR 3.11. Completion of this form is NOT a substitute for filing an assignment.

(A) NAME OF ASSIGNEE _____ (B) RESIDENCE: (CITY and STATE OR COUNTRY) _____

Please check the appropriate assignee category or categories (will not be printed on the patent) : Individual Corporation or other private group entity Government

<p>4a. The following fee(s) are enclosed:</p> <p><input type="checkbox"/> Issue Fee</p> <p><input type="checkbox"/> Publication Fee (No small entity discount permitted)</p> <p><input type="checkbox"/> Advance Order - # of Copies _____</p>	<p>4b. Payment of Fee(s):</p> <p><input type="checkbox"/> A check in the amount of the fee(s) is enclosed.</p> <p><input type="checkbox"/> Payment by credit card. Form PTO-2038 is attached.</p> <p><input type="checkbox"/> The Director is hereby authorized by charge the required fee(s), or credit any overpayment, to Deposit Account Number _____ (enclose an extra copy of this form).</p>
--	---

5. Change in Entity Status (from status indicated above)

a. Applicant claims SMALL ENTITY status. See 37 CFR 1.27. b. Applicant is no longer claiming SMALL ENTITY status. See 37 CFR 1.27(g)(2).

The Director of the USPTO is requested to apply the Issue Fee and Publication Fee (if any) or to re-apply any previously paid issue fee to the application identified above. NOTE: The Issue Fee and Publication Fee (if required) will not be accepted from anyone other than the applicant; a registered attorney or agent; or the assignee or other party in interest as shown by the records of the United States Patent and Trademark Office.

Authorized Signature _____ Date _____

Typed or printed name _____ Registration No. _____

This collection of information is required by 37 CFR 1.311. The information is required to obtain or retain a benefit by the public which is to file (and by the USPTO to process) an application. Confidentiality is governed by 35 U.S.C. 122 and 37 CFR 1.14. This collection is estimated to take 12 minutes to complete, including gathering, preparing, and submitting the completed application form to the USPTO. Time will vary depending upon the individual case. Any comments on the amount of time you require to complete this form and/or suggestions for reducing this burden, should be sent to the Chief Information Officer, U.S. Patent and Trademark Office, U.S. Department of Commerce, P.O. Box 1450, Alexandria, Virginia 22313-1450. DO NOT SEND FEES OR COMPLETED FORMS TO THIS ADDRESS. SEND TO: Commissioner for Patents, P.O. Box 1450, Alexandria, Virginia 22313-1450.

Under the Paperwork Reduction Act of 1995, no persons are required to respond to a collection of information unless it displays a valid OMB control number.



UNITED STATES PATENT AND TRADEMARK OFFICE

UNITED STATES DEPARTMENT OF COMMERCE
United States Patent and Trademark Office
Address: COMMISSIONER FOR PATENTS
P.O. Box 1450
Alexandria, Virginia 22313-1450
www.uspto.gov

Table with columns: APPLICATION NO., FILING DATE, FIRST NAMED INVENTOR, ATTORNEY DOCKET NO., CONFIRMATION NO., EXAMINER, ART UNIT, PAPER NUMBER. Includes application details for Alain Delpuch and examiner BUI, KIEU OANH T.

DATE MAILED: 06/29/2005

Determination of Patent Term Adjustment under 35 U.S.C. 154 (b)
(application filed on or after May 29, 2000)

The Patent Term Adjustment to date is 149 day(s). If the issue fee is paid on the date that is three months after the mailing date of this notice and the patent issues on the Tuesday before the date that is 28 weeks (six and a half months) after the mailing date of this notice, the Patent Term Adjustment will be 149 day(s).

If a Continued Prosecution Application (CPA) was filed in the above-identified application, the filing date that determines Patent Term Adjustment is the filing date of the most recent CPA.

Applicant will be able to obtain more detailed information by accessing the Patent Application Information Retrieval (PAIR) WEB site (http://pair.uspto.gov).

Any questions regarding the Patent Term Extension or Adjustment determination should be directed to the Office of Patent Legal Administration at (571) 272-7702. Questions relating to issue and publication fee payments should be directed to the Customer Service Center of the Office of Patent Publication at (703) 305-8283.

Notice of Allowability

Application No.	Applicant(s)	
10/419,621	DELPUCH ET AL.	
Examiner	Art Unit	
KIEU-OANH T. BUI	2611	

-- The MAILING DATE of this communication appears on the cover sheet with the correspondence address--

All claims being allowable, PROSECUTION ON THE MERITS IS (OR REMAINS) CLOSED in this application. If not included herewith (or previously mailed), a Notice of Allowance (PTOL-85) or other appropriate communication will be mailed in due course. **THIS NOTICE OF ALLOWABILITY IS NOT A GRANT OF PATENT RIGHTS.** This application is subject to withdrawal from issue at the initiative of the Office or upon petition by the applicant. See 37 CFR 1.313 and MPEP 1308.

- 1. This communication is responsive to Amendment filed on 01/21/2005.
- 2. The allowed claim(s) is/are 1-23.
- 3. The drawings filed on 21 April 2003 are accepted by the Examiner.
- 4. Acknowledgment is made of a claim for foreign priority under 35 U.S.C. § 119(a)-(d) or (f).
 - a) All b) Some* c) None of the:
 - 1. Certified copies of the priority documents have been received.
 - 2. Certified copies of the priority documents have been received in Application No. _____.
 - 3. Copies of the certified copies of the priority documents have been received in this national stage application from the International Bureau (PCT Rule 17.2(a)).

* Certified copies not received: _____.

Applicant has THREE MONTHS FROM THE "MAILING DATE" of this communication to file a reply complying with the requirements noted below. Failure to timely comply will result in ABANDONMENT of this application.
THIS THREE-MONTH PERIOD IS NOT EXTENDABLE.

- 5. A SUBSTITUTE OATH OR DECLARATION must be submitted. Note the attached EXAMINER'S AMENDMENT or NOTICE OF INFORMAL PATENT APPLICATION (PTO-152) which gives reason(s) why the oath or declaration is deficient.
 - 6. CORRECTED DRAWINGS (as "replacement sheets") must be submitted.
 - (a) including changes required by the Notice of Draftsperson's Patent Drawing Review (PTO-948) attached
 - 1) hereto or 2) to Paper No./Mail Date _____.
 - (b) including changes required by the attached Examiner's Amendment / Comment or in the Office action of Paper No./Mail Date _____.
- Identifying indicia such as the application number (see 37 CFR 1.84(c)) should be written on the drawings in the front (not the back) of each sheet. Replacement sheet(s) should be labeled as such in the header according to 37 CFR 1.121(d).**
- 7. DEPOSIT OF and/or INFORMATION about the deposit of BIOLOGICAL MATERIAL must be submitted. Note the attached Examiner's comment regarding REQUIREMENT FOR THE DEPOSIT OF BIOLOGICAL MATERIAL.

Attachment(s)

- 1. Notice of References Cited (PTO-892)
- 2. Notice of Draftsperson's Patent Drawing Review (PTO-948)
- 3. Information Disclosure Statements (PTO-1449 or PTO/SB/08), Paper No./Mail Date _____
- 4. Examiner's Comment Regarding Requirement for Deposit of Biological Material
- 5. Notice of Informal Patent Application (PTO-152)
- 6. Interview Summary (PTO-413), Paper No./Mail Date _____
- 7. Examiner's Amendment/Comment
- 8. Examiner's Statement of Reasons for Allowance
- 9. Other _____.

DETAILED ACTION

Allowable Subject Matter

1. Claims 1-23 are allowed.

Reasons for Allowance

2. The following is an examiner's statement of reasons for allowance:

Regarding claims 1, 13, 22 and 23, the closest prior art issued to Ben fails to teach or suggest all of the steps of "determining whether said one or more directives includes a prerequisite directive which indicates that acquisition of a subset of said set of resources is a prerequisite for initiating the presentation; initiating said presentation. in response to determining the one or more directives do not include said prerequisite directive; and prohibiting initiation of said presentation until said subset of resources are acquired. in response to determining the one or more directives include said prerequisite directive" as amended in claims.

Any comments considered necessary by applicant must be submitted no later than the payment of the issue fee and, to avoid processing delays, should preferably accompany the issue fee. Such submissions should be clearly labeled "Comments on Statement of Reasons for Allowance."

Conclusion

3. **Any response to this action should be mailed to:**

Commissioner of Patents and Trademarks

Washington, D.C. 20231

or faxed to:

(703) 872-9306, (for Technology Center 2600 only)

Art Unit: 2611

4. Any inquiry concerning this communication or earlier communications from the examiner should be directed to Kieu-Oanh Bui whose telephone number is (571) 272-7291. The examiner can normally be reached on Monday-Friday from 9:00 AM to 6:30 PM, with alternate Fridays off.

If attempts to reach the examiner by telephone are unsuccessful, the examiner's supervisor, Christopher Grant, can be reached on (571) 272-7294.

Information regarding the status of an application may be obtained from the Patent Application Information Retrieval (PAIR) system. Status information for published applications may be obtained from either Private PAIR or Public PAIR. Status information for unpublished applications is available through Private PAIR only. For more information about the PAIR system, see <http://pair-direct.uspto.gov>. Should you have questions on access to the Private PAIR system, contact the Electronic Business Center (EBC) at 866-217-9197 (toll-free).



Kieu-Oanh Bui
Primary Examiner
Art Unit 2611

KB
June 9, 2005

Issue Classification 	Application/Control No. 10/419,621	Applicant(s)/Patent under Reexamination DELPUCH ET AL.	
	Examiner KIEU-OANH T. BUI	Art Unit 2611	

ISSUE CLASSIFICATION										
ORIGINAL					CROSS REFERENCE(S)					
CLASS		SUBCLASS			CLASS	SUBCLASS (ONE SUBCLASS PER BLOCK)				
725		100			725	91	138	139		
INTERNATIONAL CLASSIFICATION										
H	0	4	N	7/173						
H	0	4	N	7/16						
				/						
				/						
				/						

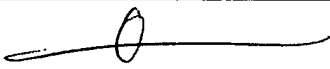
 (Assistant Examiner) (Date)	Kieu-Oanh Bui Primary Examiner Art Unit 2611 (Primary Examiner) (Date)	Total Claims Allowed: 23 <table border="1" style="width: 100%;"> <tr> <td style="width: 50%;">O.G. Print Claim(s)</td> <td style="width: 50%;">O.G. Print Fig.</td> </tr> <tr> <td style="text-align: center;">13</td> <td style="text-align: center;">05</td> </tr> </table>	O.G. Print Claim(s)	O.G. Print Fig.	13	05
O.G. Print Claim(s)	O.G. Print Fig.					
13	05					

<input type="checkbox"/> Claims renumbered in the same order as presented by applicant																<input type="checkbox"/> CPA		<input type="checkbox"/> T.D.		<input type="checkbox"/> R.1.47	
Final	Original	Final	Original	Final	Original	Final	Original	Final	Original	Final	Original	Final	Original	Final	Original						
1	1		31		61		91		121		151		181								
2	2		32		62		92		122		152		182								
3	3		33		63		93		123		153		183								
4	4		34		64		94		124		154		184								
5	5		35		65		95		125		155		185								
6	6		36		66		96		126		156		186								
7	7		37		67		97		127		157		187								
8	8		38		68		98		128		158		188								
9	9		39		69		99		129		159		189								
10	10		40		70		100		130		160		190								
11	11		41		71		101		131		161		191								
12	12		42		72		102		132		162		192								
13	13		43		73		103		133		163		193								
14	14		44		74		104		134		164		194								
15	15		45		75		105		135		165		195								
16	16		46		76		106		136		166		196								
17	17		47		77		107		137		167		197								
18	18		48		78		108		138		168		198								
19	19		49		79		109		139		169		199								
20	20		50		80		110		140		170		200								
21	21		51		81		111		141		171		201								
22	22		52		82		112		142		172		202								
23	23		53		83		113		143		173		203								
	24		54		84		114		144		174		204								
	25		55		85		115		145		175		205								
	26		56		86		116		146		176		206								
	27		57		87		117		147		177		207								
	28		58		88		118		148		178		208								
	29		59		89		119		149		179		209								
	30		60		90		120		150		180		210								

#10



UNITED STATES PATENT AND TRADEMARK OFFICE

UNITED STATES DEPARTMENT OF COMMERCE
United States Patent and Trademark Office
Address: COMMISSIONER FOR PATENTS
P.O. Box 1450
Alexandria, Virginia 22313-1450
www.uspto.gov



Bib Data Sheet

CONFIRMATION NO. 2305

SERIAL NUMBER 10/419,621	FILING OR 371(c) DATE 04/21/2003 RULE 1.47	CLASS 725	GROUP ART UNIT 2611	ATTORNEY DOCKET NO. 5266-06201
------------------------------------	--	---------------------	-------------------------------	--

APPLICANTS

Alain Delpuch, Les Essarts Le Roi, FRANCE;
James Whitledge, Naperville, IL;
Jean-Rene Menand, Los Altos, CA;
Emmanuel Barbier, Paris, FRANCE;
Kevin Hausman, Naperville, IL;
Debra Hensgen, Redwood City, CA;
Dongmin Su, Santa Clara, CA;

Provisional Application

** CONTINUING DATA *****

This appln claims benefit of 60/373,883 04/19/2002

** FOREIGN APPLICATIONS *****

IF REQUIRED, FOREIGN FILING LICENSE GRANTED **

06/17/2003

Foreign Priority claimed <input type="checkbox"/> yes <input type="checkbox"/> no	STATE OR COUNTRY FRANCE	SHEETS DRAWING 5	TOTAL CLAIMS 23	INDEPENDENT CLAIMS 4
35 USC 119 (a-d) conditions met <input type="checkbox"/> yes <input type="checkbox"/> no <input type="checkbox"/> Met after Allowance				
Verified and Acknowledged Examiner's Signature _____ Initials _____				

ADDRESS

35690

TITLE

Supporting common interactive television functionality through presentation engine syntax

FILING FEE RECEIVED 1018	FEEs: Authority has been given in Paper No. _____ to charge/credit DEPOSIT ACCOUNT No. _____ for following:	<input type="checkbox"/> All Fees <input type="checkbox"/> 1.16 Fees (Filing) <input type="checkbox"/> 1.17 Fees (Processing Ext. of time) <input type="checkbox"/> 1.18 Fees (Issue) <input type="checkbox"/> Other _____ <input type="checkbox"/> Credit
------------------------------------	---	---

BEST AVAILABLE COPY

Search Notes



Application/Control No.

10/419,621

Applicant(s)/Patent under Reexamination

DELPUCH ET AL.

Examiner

KIEU-OANH T. BUI

Art Unit

2611

SEARCHED			
Class	Subclass	Date	Examiner
725	91,100, 109,112, 135,139	6/6/2005	KB
709	217, 223,	6/7/2005	
	225,226,		
	231		
710	48,266		

SEARCH NOTES (INCLUDING SEARCH STRATEGY)		
	DATE	EXMR
Updated search 725	6/6/2005	KB
Zani Muang 709 Park Ilwoo 710	6/7/2005	KB

INTERFERENCE SEARCHED			
Class	Subclass	Date	Examiner
725	91,100,	6/9/2005	KB
	135,139		



UNITED STATES PATENT AND TRADEMARK OFFICE

UNITED STATES DEPARTMENT OF COMMERCE
United States Patent and Trademark Office
Address: COMMISSIONER FOR PATENTS
P.O. Box 1450
Alexandria, Virginia 22313-1450
www.uspto.gov

APPLICATION NO.	FILING DATE	FIRST NAMED INVENTOR	ATTORNEY DOCKET NO.	CONFIRMATION NO.
10/419,621	04/21/2003	Alain Delpuch	5266-06201	2305

44015 7590 07/14/2005

OPTV/MEYERTONS
THE CHASE BUILDING
700 LAVACA, SUITE 800
AUSTIN, TX 78701

EXAMINER

BUI, KIEU OANH T

ART UNIT PAPER NUMBER

2611

DATE MAILED: 07/14/2005

Please find below and/or attached an Office communication concerning this application or proceeding.

**Supplemental
Notice of Allowability**

Application No.

10/419,621

Applicant(s)

DELPUCH ET AL.

Examiner

KIEU-OANH T. BUI

Art Unit

2611

-- The MAILING DATE of this communication appears on the cover sheet with the correspondence address--

All claims being allowable, PROSECUTION ON THE MERITS IS (OR REMAINS) CLOSED in this application. If not included herewith (or previously mailed), a Notice of Allowance (PTOL-85) or other appropriate communication will be mailed in due course. **THIS NOTICE OF ALLOWABILITY IS NOT A GRANT OF PATENT RIGHTS.** This application is subject to withdrawal from issue at the initiative of the Office or upon petition by the applicant. See 37 CFR 1.313 and MPEP 1308.

1. This communication is responsive to Amendment filed on 1/21/2005.
2. The allowed claim(s) is/are 1-23.
3. The drawings filed on _____ are accepted by the Examiner.
4. Acknowledgment is made of a claim for foreign priority under 35 U.S.C. § 119(a)-(d) or (f).
 - a) All b) Some* c) None of the:
 1. Certified copies of the priority documents have been received.
 2. Certified copies of the priority documents have been received in Application No. _____.
 3. Copies of the certified copies of the priority documents have been received in this national stage application from the International Bureau (PCT Rule 17.2(a)).

* Certified copies not received: _____.

Applicant has THREE MONTHS FROM THE "MAILING DATE" of this communication to file a reply complying with the requirements noted below. Failure to timely comply will result in ABANDONMENT of this application.
THIS THREE-MONTH PERIOD IS NOT EXTENDABLE.

5. A SUBSTITUTE OATH OR DECLARATION must be submitted. Note the attached EXAMINER'S AMENDMENT or NOTICE OF INFORMAL PATENT APPLICATION (PTO-152) which gives reason(s) why the oath or declaration is deficient.
 6. CORRECTED DRAWINGS (as "replacement sheets") must be submitted.
 - (a) including changes required by the Notice of Draftsperson's Patent Drawing Review (PTO-948) attached
 - 1) hereto or 2) to Paper No./Mail Date _____.
 - (b) including changes required by the attached Examiner's Amendment / Comment or in the Office action of Paper No./Mail Date _____.
- Identifying indicia such as the application number (see 37 CFR 1.84(c)) should be written on the drawings in the front (not the back) of each sheet. Replacement sheet(s) should be labeled as such in the header according to 37 CFR 1.121(d).
7. DEPOSIT OF and/or INFORMATION about the deposit of BIOLOGICAL MATERIAL must be submitted. Note the attached Examiner's comment regarding REQUIREMENT FOR THE DEPOSIT OF BIOLOGICAL MATERIAL.

Attachment(s)

- | | |
|---|--|
| 1. <input type="checkbox"/> Notice of References Cited (PTO-892) | 5. <input type="checkbox"/> Notice of Informal Patent Application (PTO-152) |
| 2. <input type="checkbox"/> Notice of Draftsperson's Patent Drawing Review (PTO-948) | 6. <input checked="" type="checkbox"/> Interview Summary (PTO-413),
Paper No./Mail Date _____ |
| 3. <input type="checkbox"/> Information Disclosure Statements (PTO-1449 or PTO/SB/08),
Paper No./Mail Date _____ | 7. <input checked="" type="checkbox"/> Examiner's Amendment/Comment |
| 4. <input type="checkbox"/> Examiner's Comment Regarding Requirement for Deposit
of Biological Material | 8. <input type="checkbox"/> Examiner's Statement of Reasons for Allowance |
| | 9. <input type="checkbox"/> Other _____ |



CHRIS GRANT
PRIMARY EXAMINER

Art Unit: 2611

EXAMINER'S AMENDMENT

1. An examiner's amendment to the record appears below. Should the changes and/or additions be unacceptable to applicant, an amendment may be filed as provided by 37 CFR 1.312. To ensure consideration of such an amendment, it MUST be submitted no later than the payment of the issue fee.

Authorization for this examiner's amendment was given in a telephone interview with Rory Rankin on 7/7/2005.

The application has been amended as follows:

In the claims:

In claim 23, lines 1-2, "A carrier medium comprising program instructions executable to"

has been changed to

--A computer readable medium comprising program instructions executable by a computer to --

Claim 23 was amended to be in compliance with 35 USC 101.

Art Unit: 2611

Any inquiry concerning this communication or earlier communications from the examiner should be directed to Kieu-Oanh T. Bui whose telephone number is (571) 272 7291.

The examiner can normally be reached on Monday-Friday 9:00am - 6:30pm.

If attempts to reach the examiner by telephone are unsuccessful, the examiner's supervisor, Chris Grant can be reached on (571) 272 7294. The fax phone number for the organization where this application or proceeding is assigned is 703-872-9306.

Information regarding the status of an application may be obtained from the Patent Application Information Retrieval (PAIR) system. Status information for published applications may be obtained from either Private PAIR or Public PAIR. Status information for unpublished applications is available through Private PAIR only. For more information about the PAIR system, see <http://pair-direct.uspto.gov>. Should you have questions on access to the Private PAIR system, contact the Electronic Business Center (EBC) at 866-217-9197 (toll-free).



CHRIS GRANT
PRIMARY EXAMINER

Interview Summary	Application No. 10/419,621	Applicant(s) DELPUCH ET AL.	
	Examiner Christopher Grant	Art Unit 2611	

All participants (applicant, applicant's representative, PTO personnel):

- (1) Christopher Grant. (3) _____.
- (2) Rory Rankin. (4) _____.

Date of Interview: 7/7/05.

Type: a) Telephonic b) Video Conference
c) Personal [copy given to: 1) applicant 2) applicant's representative]

Exhibit shown or demonstration conducted: d) Yes e) No.
If Yes, brief description: _____.

Claim(s) discussed: 23.

Identification of prior art discussed: none.

Agreement with respect to the claims f) was reached. g) was not reached. h) N/A.

Substance of Interview including description of the general nature of what was agreed to if an agreement was reached, or any other comments: Discussed changes to make claim 23 in compliance with 35 USC 101.

(A fuller description, if necessary, and a copy of the amendments which the examiner agreed would render the claims allowable, if available, must be attached. Also, where no copy of the amendments that would render the claims allowable is available, a summary thereof must be attached.)

THE FORMAL WRITTEN REPLY TO THE LAST OFFICE ACTION MUST INCLUDE THE SUBSTANCE OF THE INTERVIEW. (See MPEP Section 713.04). If a reply to the last Office action has already been filed, APPLICANT IS GIVEN ONE MONTH FROM THIS INTERVIEW DATE, OR THE MAILING DATE OF THIS INTERVIEW SUMMARY FORM, WHICHEVER IS LATER, TO FILE A STATEMENT OF THE SUBSTANCE OF THE INTERVIEW. See Summary of Record of Interview requirements on reverse side or on attached sheet.



CHRIS GRANT
PRIMARY EXAMINER

Examiner Note: You must sign this form unless it is an Attachment to a signed Office action.

Examiner's signature, if required

Summary of Record of Interview Requirements

Manual of Patent Examining Procedure (MPEP), Section 713.04, Substance of Interview Must be Made of Record

A complete written statement as to the substance of any face-to-face, video conference, or telephone interview with regard to an application must be made of record in the application whether or not an agreement with the examiner was reached at the interview.

Title 37 Code of Federal Regulations (CFR) § 1.133 Interviews Paragraph (b)

In every instance where reconsideration is requested in view of an interview with an examiner, a complete written statement of the reasons presented at the interview as warranting favorable action must be filed by the applicant. An interview does not remove the necessity for reply to Office action as specified in §§ 1.111, 1.135. (35 U.S.C. 132)

37 CFR §1.2 Business to be transacted in writing.

All business with the Patent or Trademark Office should be transacted in writing. The personal attendance of applicants or their attorneys or agents at the Patent and Trademark Office is unnecessary. The action of the Patent and Trademark Office will be based exclusively on the written record in the Office. No attention will be paid to any alleged oral promise, stipulation, or understanding in relation to which there is disagreement or doubt.

The action of the Patent and Trademark Office cannot be based exclusively on the written record in the Office if that record is itself incomplete through the failure to record the substance of interviews.

It is the responsibility of the applicant or the attorney or agent to make the substance of an interview of record in the application file, unless the examiner indicates he or she will do so. It is the examiner's responsibility to see that such a record is made and to correct material inaccuracies which bear directly on the question of patentability.

Examiners must complete an Interview Summary Form for each interview held where a matter of substance has been discussed during the interview by checking the appropriate boxes and filling in the blanks. Discussions regarding only procedural matters, directed solely to restriction requirements for which interview recordation is otherwise provided for in Section 812.01 of the Manual of Patent Examining Procedure, or pointing out typographical errors or unreadable script in Office actions or the like, are excluded from the interview recordation procedures below. Where the substance of an interview is completely recorded in an Examiners Amendment, no separate Interview Summary Record is required.

The Interview Summary Form shall be given an appropriate Paper No., placed in the right hand portion of the file, and listed on the "Contents" section of the file wrapper. In a personal interview, a duplicate of the Form is given to the applicant (or attorney or agent) at the conclusion of the interview. In the case of a telephone or video-conference interview, the copy is mailed to the applicant's correspondence address either with or prior to the next official communication. If additional correspondence from the examiner is not likely before an allowance or if other circumstances dictate, the Form should be mailed promptly after the interview rather than with the next official communication.

The Form provides for recordation of the following information:

- Application Number (Series Code and Serial Number)
- Name of applicant
- Name of examiner
- Date of interview
- Type of interview (telephonic, video-conference, or personal)
- Name of participant(s) (applicant, attorney or agent, examiner, other PTO personnel, etc.)
- An indication whether or not an exhibit was shown or a demonstration conducted
- An identification of the specific prior art discussed
- An indication whether an agreement was reached and if so, a description of the general nature of the agreement (may be by attachment of a copy of amendments or claims agreed as being allowable). Note: Agreement as to allowability is tentative and does not restrict further action by the examiner to the contrary.
- The signature of the examiner who conducted the interview (if Form is not an attachment to a signed Office action)

It is desirable that the examiner orally remind the applicant of his or her obligation to record the substance of the interview of each case. It should be noted, however, that the Interview Summary Form will not normally be considered a complete and proper recordation of the interview unless it includes, or is supplemented by the applicant or the examiner to include, all of the applicable items required below concerning the substance of the interview.

A complete and proper recordation of the substance of any interview should include at least the following applicable items:

- 1) A brief description of the nature of any exhibit shown or any demonstration conducted,
- 2) an identification of the claims discussed,
- 3) an identification of the specific prior art discussed,
- 4) an identification of the principal proposed amendments of a substantive nature discussed, unless these are already described on the Interview Summary Form completed by the Examiner,
- 5) a brief identification of the general thrust of the principal arguments presented to the examiner,
(The identification of arguments need not be lengthy or elaborate. A verbatim or highly detailed description of the arguments is not required. The identification of the arguments is sufficient if the general nature or thrust of the principal arguments made to the examiner can be understood in the context of the application file. Of course, the applicant may desire to emphasize and fully describe those arguments which he or she feels were or might be persuasive to the examiner.)
- 6) a general indication of any other pertinent matters discussed, and
- 7) if appropriate, the general results or outcome of the interview unless already described in the Interview Summary Form completed by the examiner.

Examiners are expected to carefully review the applicant's record of the substance of an interview. If the record is not complete and accurate, the examiner will give the applicant an extendable one month time period to correct the record.

Examiner to Check for Accuracy

If the claims are allowable for other reasons of record, the examiner should send a letter setting forth the examiner's version of the statement attributed to him or her. If the record is complete and accurate, the examiner should place the indication, "Interview Record OK" on the paper recording the substance of the interview along with the date and the examiner's initials.

PART B - FEE(S) TRANSMITTAL

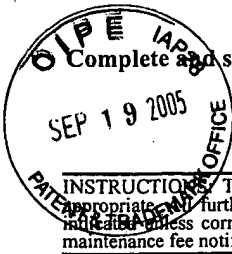

Complete and send this form, together with applicable fee(s), to: **Mail**

**Mail Stop ISSUE FEE
Commissioner for Patents
P.O. Box 1450
Alexandria, Virginia 22313-1450
(703) 746-4000**

or **Fax**

INSTRUCTIONS: This form should be used for transmitting the ISSUE FEE and PUBLICATION FEE (if required). Blocks 1 through-5 should be completed where appropriate. Further correspondence including the Patent, advance orders and notification of maintenance fees will be mailed to the current correspondence address as indicated below or directed otherwise in Block 1, by (a) specifying a new correspondence address; and/or (b) indicating a separate "FEE ADDRESS" for maintenance fee notifications.

CURRENT CORRESPONDENCE ADDRESS (Note: Use Block 1 for any change of address)

44015 7590 06/29/2005

OPTV/MEYERTONS
THE CHASE BUILDING
700 LAVACA, SUITE 800
AUSTIN, TX 78701

09/20/2005 HDESTA2 00000045 501505 10419621

01 FC:1501 1400.00 DA
02 FC:1504 300.00 DA

Note: A certificate of mailing can only be used for domestic mailings of the Fee(s) Transmittal. This certificate cannot be used for any other accompanying papers. Each additional paper, such as an assignment or formal drawing, must have its own certificate of mailing or transmission.

Certificate of Mailing or Transmission
I hereby certify that this Fee(s) Transmittal is being deposited with the United States Postal Service with sufficient postage for first class mail in an envelope addressed to the Mail Stop ISSUE FEE address above, or being facsimile transmitted to the USPTO (703) 746-4000, on the date indicated below.

Rory D. Rankin	(Depositor's name)
	(Signature)
9/16/05	(Date)

APPLICATION NO.	FILING DATE	FIRST NAMED INVENTOR	ATTORNEY DOCKET NO.	CONFIRMATION NO.
10/419,621	04/21/2003	Alain Delpuch	5266-06201	2305

TITLE OF INVENTION: SUPPORTING COMMON INTERACTIVE TELEVISION FUNCTIONALITY THROUGH PRESENTATION ENGINE SYNTAX

APPLN. TYPE	SMALL ENTITY	ISSUE FEE	PUBLICATION FEE	TOTAL FEE(S) DUE	DATE DUE
nonprovisional	NO	\$1400	\$300	\$1700	09/29/2005

EXAMINER	ART UNIT	CLASS-SUBCLASS
BUI, KIEU OANH T	2611	725-093000

1. Change of correspondence address or indication of "Fee Address" (37 CFR 1.363).
 Change of correspondence address (or Change of Correspondence Address form PTO/SB/122) attached.
 "Fee Address" indication (or "Fee Address" Indication form PTO/SB/47; Rev 03-02 or more recent) attached. Use of a Customer Number is required.

2. For printing on the patent front page, list
 (1) the names of up to 3 registered patent attorneys or agents OR, alternatively,
 (2) the name of a single firm (having as a member a registered attorney or agent) and the names of up to 2 registered patent attorneys or agents. If no name is listed, no name will be printed.
 Meyertons Hood Kivlin
 1. Kowert & Goetzel, P.C.
 2. Rory D. Rankin
 3.

3. ASSIGNEE NAME AND RESIDENCE DATA TO BE PRINTED ON THE PATENT (print or type)

PLEASE NOTE: Unless an assignee is identified below, no assignee data will appear on the patent. If an assignee is identified below, the document has been filed for recordation as set forth in 37 CFR 3.11. Completion of this form is NOT a substitute for filing an assignment.

(A) NAME OF ASSIGNEE (B) RESIDENCE: (CITY and STATE OR COUNTRY)

OpenTV, Inc. San Francisco, CA

Please check the appropriate assignee category or categories (will not be printed on the patent): Individual Corporation or other private group entity Government

4a. The following fee(s) are enclosed:

- Issue Fee
- Publication Fee (No small entity discount permitted)
- Advance Order - # of Copies _____

4b. Payment of Fee(s):

- A check in the amount of the fee(s) is enclosed.
- Payment by credit card. Form PTO-2038 is attached.
- The Director is hereby authorized by charge the required fee(s), or credit any overpayment, to Deposit Account Number 501505/5266-06201 (enclose an extra copy of this form).

5. Change in Entity Status (from status indicated above)

- a. Applicant claims SMALL ENTITY status. See 37 CFR 1.27.
- b. Applicant is no longer claiming SMALL ENTITY status. See 37 CFR 1.27(g)(2).

The Director of the USPTO is requested to apply the Issue Fee and Publication Fee (if any) or to re-apply any previously paid issue fee to the application identified above. NOTE: The Issue Fee and Publication Fee (if required) will not be accepted from anyone other than the applicant; a registered attorney or agent; or the assignee or other party in interest as shown by the records of the United States Patent and Trademark Office.

Authorized Signature _____ Date 9/16/05
 Typed or printed name Rory D. Rankin Registration No. PTO #47,884

This collection of information is required by 37 CFR 1.311. The information is required to obtain or retain a benefit by the public which is to file (and by the USPTO to process) an application. Confidentiality is governed by 35 U.S.C. 122 and 37 CFR 1.14. This collection is estimated to take 12 minutes to complete, including gathering, preparing, and submitting the completed application form to the USPTO. Time will vary depending upon the individual case. Any comments on the amount of time you require to complete this form and/or suggestions for reducing this burden, should be sent to the Chief Information Officer, U.S. Patent and Trademark Office, U.S. Department of Commerce, P.O. Box 1450, Alexandria, Virginia 22313-1450. DO NOT SEND FEES OR COMPLETED FORMS TO THIS ADDRESS. SEND TO: Commissioner for Patents, P.O. Box 1450, Alexandria, Virginia 22313-1450.

Under the Paperwork Reduction Act of 1995, no persons are required to respond to a collection of information unless it displays a valid OMB control number.

● PRINTER RUSH ●

(PTO ASSISTANCE)

Application : <u>10/419,621</u>	Examiner : <u>K. Bul</u>	GAU : <u>2611</u>
From : <u>R. MITCHELL</u>	Location : <u>(IDC) FMF FDC</u>	Date : <u>11/3/05</u>
Tracking #: <u>EPM 10/419,621</u>		Week Date: <u>7/4/05</u>

DOC CODE	DOC DATE	MISCELLANEOUS
<input type="checkbox"/> 1449	_____	<input type="checkbox"/> Continuing Data
<input type="checkbox"/> IDS	_____	<input type="checkbox"/> Foreign Priority
<input checked="" type="checkbox"/> CLM	<u>1/21/05</u>	<input type="checkbox"/> Document Legibility
<input type="checkbox"/> IIFW	_____	<input type="checkbox"/> Fees
<input type="checkbox"/> SRFW	_____	<input type="checkbox"/> Other
<input type="checkbox"/> DRW	_____	
<input type="checkbox"/> OATH	_____	
<input type="checkbox"/> 312	_____	
<input type="checkbox"/> SPEC	_____	

[RUSH] MESSAGE: CLAIM 13 HAS TWO PERIODS.

THANK YOU
REM

[XRUSH] RESPONSE: _____

INITIALS:



UNITED STATES PATENT AND TRADEMARK OFFICE

UNITED STATES DEPARTMENT OF COMMERCE
United States Patent and Trademark Office
Address: COMMISSIONER FOR PATENTS
P.O. Box 1450
Alexandria, Virginia 22313-1450
www.uspto.gov

APPLICATION NO.	FILING DATE	FIRST NAMED INVENTOR	ATTORNEY DOCKET NO.	CONFIRMATION NO.
10/419,621	04/21/2003	Alain Delpuch	5266-06201	2305

44015 7590 11/28/2005

OPTV/MEYERTONS
THE CHASE BUILDING
700 LAVACA, SUITE 800
AUSTIN, TX 78701

EXAMINER

BUI, KIEU OANH T

ART UNIT PAPER NUMBER

2611

DATE MAILED: 11/28/2005

Please find below and/or attached an Office communication concerning this application or proceeding.

Supplemental
Notice of Allowability

Application No.	Applicant(s)	
10/419,621	DELPUCH ET AL.	
Examiner	Art Unit	
KIEU-OANH T. BUI	2611	

-- The MAILING DATE of this communication appears on the cover sheet with the correspondence address--

All claims being allowable, PROSECUTION ON THE MERITS IS (OR REMAINS) CLOSED in this application. If not included herewith (or previously mailed), a Notice of Allowance (PTOL-85) or other appropriate communication will be mailed in due course. **THIS NOTICE OF ALLOWABILITY IS NOT A GRANT OF PATENT RIGHTS.** This application is subject to withdrawal from issue at the initiative of the Office or upon petition by the applicant. See 37 CFR 1.313 and MPEP 1308.

1. This communication is responsive to Amendment filed on 01/21/2005.
2. The allowed claim(s) is/are 1-23.
3. The drawings filed on 21 April 2003 are accepted by the Examiner.
4. Acknowledgment is made of a claim for foreign priority under 35 U.S.C. § 119(a)-(d) or (f).
 - a) All b) Some* c) None of the:
 1. Certified copies of the priority documents have been received.
 2. Certified copies of the priority documents have been received in Application No. _____.
 3. Copies of the certified copies of the priority documents have been received in this national stage application from the International Bureau (PCT Rule 17.2(a)).

* Certified copies not received: _____.

Applicant has THREE MONTHS FROM THE "MAILING DATE" of this communication to file a reply complying with the requirements noted below. Failure to timely comply will result in ABANDONMENT of this application.
THIS THREE-MONTH PERIOD IS NOT EXTENDABLE.

5. A SUBSTITUTE OATH OR DECLARATION must be submitted. Note the attached EXAMINER'S AMENDMENT or NOTICE OF INFORMAL PATENT APPLICATION (PTO-152) which gives reason(s) why the oath or declaration is deficient.
 6. CORRECTED DRAWINGS (as "replacement sheets") must be submitted.
 - (a) including changes required by the Notice of Draftsperson's Patent Drawing Review (PTO-948) attached
 - 1) hereto or 2) to Paper No./Mail Date _____.
 - (b) including changes required by the attached Examiner's Amendment / Comment or in the Office action of Paper No./Mail Date _____.
- Identifying indicia such as the application number (see 37 CFR 1.84(c)) should be written on the drawings in the front (not the back) of each sheet. Replacement sheet(s) should be labeled as such in the header according to 37 CFR 1.121(d).**
7. DEPOSIT OF and/or INFORMATION about the deposit of BIOLOGICAL MATERIAL must be submitted. Note the attached Examiner's comment regarding REQUIREMENT FOR THE DEPOSIT OF BIOLOGICAL MATERIAL.

Attachment(s)

- | | |
|---|--|
| 1. <input type="checkbox"/> Notice of References Cited (PTO-892) | 5. <input type="checkbox"/> Notice of Informal Patent Application (PTO-152) |
| 2. <input type="checkbox"/> Notice of Draftsperson's Patent Drawing Review (PTO-948) | 6. <input type="checkbox"/> Interview Summary (PTO-413),
Paper No./Mail Date _____. |
| 3. <input type="checkbox"/> Information Disclosure Statements (PTO-1449 or PTO/SB/08),
Paper No./Mail Date _____ | 7. <input type="checkbox"/> Examiner's Amendment/Comment |
| 4. <input type="checkbox"/> Examiner's Comment Regarding Requirement for Deposit
of Biological Material | 8. <input checked="" type="checkbox"/> Examiner's Statement of Reasons for Allowance |
| | 9. <input type="checkbox"/> Other _____. |

Supplemental

Application/Control Number: 10/419,621

Page 2

Art Unit: 2611

DETAILED ACTION

Allowable Subject Matter

1. Claims 1-23 are allowed.

Reasons for Allowance

2. The following is an examiner's statement of reasons for allowance:

Regarding claims 1, 13, 22 and 23, the closest prior art issued to Ben fails to teach or suggest all of the steps of "determining whether said one or more directives includes a prerequisite directive which indicates that acquisition of a subset of said set of resources is a prerequisite for initiating the presentation; initiating said presentation. in response to determining the one or more directives do not include said prerequisite directive; and prohibiting initiation of said presentation until said subset of resources are acquired. in response to determining the one or more directives include said prerequisite directive" as amended in claims.

Any comments considered necessary by applicant must be submitted no later than the payment of the issue fee and, to avoid processing delays, should preferably accompany the issue fee. Such submissions should be clearly labeled "Comments on Statement of Reasons for Allowance."

Conclusion

3. **Any response to this action should be mailed to:**

Commissioner of Patents and Trademarks

Washington, D.C. 20231

or faxed to:

(703) 872-9306, (for Technology Center 2600 only)

Art Unit: 2611

4. Any inquiry concerning this communication or earlier communications from the examiner should be directed to Kieu-Oanh Bui whose telephone number is (571) 272-7291. The examiner can normally be reached on Monday-Friday from 9:00 AM to 6:30 PM, with alternate Fridays off.

If attempts to reach the examiner by telephone are unsuccessful, the examiner's supervisor, Christopher Grant, can be reached on (571) 272-7294.

Information regarding the status of an application may be obtained from the Patent Application Information Retrieval (PAIR) system. Status information for published applications may be obtained from either Private PAIR or Public PAIR. Status information for unpublished applications is available through Private PAIR only. For more information about the PAIR system, see <http://pair-direct.uspto.gov>. Should you have questions on access to the Private PAIR system, contact the Electronic Business Center (EBC) at 866-217-9197 (toll-free).



Kieu-Oanh Bui
Primary Examiner
Art Unit 2611

KB
June 9, 2005

PRINTER RUSH

(PTO ASSISTANCE)

Application :	<u>10/419,621</u>	Examiner :	<u>K. Bui</u>	GAU :	<u>2611</u>
From :	<u>R. MITCHELL</u>	Location :	<u>(IDC) FMF FDC</u>	Date :	<u>11/3/05</u>

Tracking #: EPM 10/419,621 Week Date: 7/4/05

DOC CODE	DOC DATE	MISCELLANEOUS
<input type="checkbox"/> 1449		<input type="checkbox"/> Continuing Data
<input type="checkbox"/> IDS		<input type="checkbox"/> Foreign Priority
<input checked="" type="checkbox"/> CLM	<u>1/21/05</u>	<input type="checkbox"/> Document Legibility
<input type="checkbox"/> IIFW		<input type="checkbox"/> Fees
<input type="checkbox"/> SRFW		<input type="checkbox"/> Other
<input type="checkbox"/> DRW		
<input type="checkbox"/> OATH		
<input type="checkbox"/> 312		
<input type="checkbox"/> SPEC		

[RUSH] MESSAGE: CLAIM 13 HAS TWO PERIODS.

THANK YOU
REM

[XRUSH] RESPONSE: Corrected - Please process this case

INITIALS: KB

NOTE: This form will be included as part of the official USPTO record, with the Response document coded as XRUSH.

Application Serial No. 10/419,621 - Filed April 21, 2003

IN THE UNITED STATES PATENT AND TRADEMARK OFFICE

Application No.: 10/419,621

Filed: April 21, 2003

Inventor(s):
Delpuch, et al.

Title: SUPPORTING COMMON
INTERACTIVE
TELEVISION
FUNCTIONALITY
THROUGH
PRESENTATION ENGINE
SYNTAX

§
§
§
§
§
§
§
§
§
§
§

Examiner: Bui, Kieu Oanh T.
Group/Art Unit: 2611
Atty. Dkt. No: 5266-06201

I hereby certify that this correspondence is being sent via facsimile to: Facsimile No. 703-746-6860, Commissioner for Patents, P.O. Box 1450, Alexandria, VA 22313-1450, on the date indicated below:

Rory D. Rankin
Printed Name

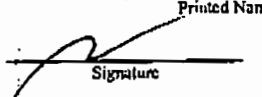
 November 21, 2005
Signature Date

Commissioner for Patents
P.O. Box 1450
Alexandria, VA 22313-1450

Dear Madam:

Pursuant to your request, a copy of claim 13 is provided below. Correction of a typographical error is also indicated. Authorization to make the noted correction is provided.

13. (Currently Amended) An interactive television system comprising:

a remote proxy server configured to:

receive one or more directives, wherein said directives are indicative of an audio, video and/or graphic presentation which requires a set of resources;

Please enter KB 11/16/05

Application Serial No. 10/419,621 - Filed April 21, 2003

determine whether said one or more directives includes a prerequisite
 directive which indicates that acquisition of a subset of said set of
 resources is a prerequisite for initiating the presentation;
 convey first signals which identify said subset of resources to a remote
 client device, in response to determining the one or more directives
 include said prerequisite directive; and
 convey second signals which correspond to said one or more
 directives[.]:

a client device configured to:

- receive said first signals;
- receive said second signals; and
- prohibit initiation of said presentation until said subset of resources are
 acquired, in response to detecting said first signals.

Please contact me at (512) 853-8866 should any issues remain.

Respectfully submitted,

Rory D. Rankin
 Reg. No. 47,884
 ATTORNEY FOR APPLICANT(S)

Meyertons, Hood, Kivlin,
 Kowert, & Goetzel, P.C.
 P.O. Box 398
 Austin, TX 78767-0398
 Phone: (512) 853-8800

Date: November 21, 2005

Issue Classification 	Application/Control No.	Applicant(s)/Patent under Reexamination	
	10/419,621	DELPUCH ET AL.	
Examiner	KIEU-OANH T. BUI	Art Unit	2611

ISSUE CLASSIFICATION										
ORIGINAL					CROSS REFERENCE(S)					
CLASS		SUBCLASS			CLASS	SUBCLASS (ONE SUBCLASS PER BLOCK)				
725		100			725	91	138	139		
INTERNATIONAL CLASSIFICATION										
H	0	4	N	7/173						
H	0	4	N	7/16						
				/						
				/						
				/						

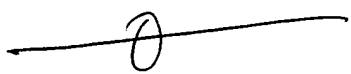
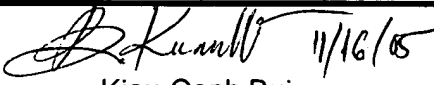
 (Assistant Examiner) (Date)	 Kieu-Oanh Bui Primary Examiner Art Unit 2611 (Primary Examiner) (Date)	Total Claims Allowed: 23 <table border="1" style="width: 100%;"> <tr> <td style="text-align: center;">O.G. Print Claim(s)</td> <td style="text-align: center;">O.G. Print Fig.</td> </tr> <tr> <td style="text-align: center;">13</td> <td style="text-align: center;">05</td> </tr> </table>	O.G. Print Claim(s)	O.G. Print Fig.	13	05
O.G. Print Claim(s)	O.G. Print Fig.					
13	05					

<input type="checkbox"/> Claims renumbered in the same order as presented by applicant		<input type="checkbox"/> CPA		<input type="checkbox"/> T.D.		<input type="checkbox"/> R.1.47					
Final	Original	Final	Original	Final	Original	Final	Original				
1	1		31		61		121		151		181
2	2		32		62		122		152		182
3	3		33		63		123		153		183
4	4		34		64		124		154		184
5	5		35		65		125		155		185
6	6		36		66		126		156		186
7	7		37		67		127		157		187
8	8		38		68		128		158		188
9	9		39		69		129		159		189
10	10		40		70		130		160		190
11	11		41		71		131		161		191
12	12		42		72		132		162		192
13	13		43		73		133		163		193
14	14		44		74		134		164		194
15	15		45		75		135		165		195
16	16		46		76		136		166		196
17	17		47		77		137		167		197
18	18		48		78		138		168		198
19	19		49		79		139		169		199
20	20		50		80		140		170		200
21	21		51		81		141		171		201
22	22		52		82		142		172		202
23	23		53		83		143		173		203
	24		54		84		144		174		204
	25		55		85		145		175		205
	26		56		86		146		176		206
	27		57		87		147		177		207
	28		58		88		148		178		208
	29		59		89		149		179		209
	30		60		90		150		180		210

Search Notes



Application/Control No.

10/419,621

Examiner

KIEU-OANH T. BUI

Applicant(s)/Patent under Reexamination

DELPUCH ET AL.

Art Unit

2611

SEARCHED

Class	Subclass	Date	Examiner
725	91,100, 109,112, 135,139	6/6/2005	KB
709	217, 223,	6/7/2005	
	225,226,		
	231		
710	48,266		

INTERFERENCE SEARCHED

Class	Subclass	Date	Examiner
725	91,100,	6/9/2005	KB
	135,139		

**SEARCH NOTES
(INCLUDING SEARCH STRATEGY)**

	DATE	EXMR
Updated search 725	6/6/2005	KB
Zani Muang 709 Park Ilwoo 710	6/7/2005	KB

RECEIVED
CENTRAL FAX CENTER

MAY 22 2012

MODIFIED PTO/SB/20 (11-08)

Approved for use through 11/30/2011. OMB 0651-0035

U.S. Patent and Trademark Office; U.S. DEPARTMENT OF COMMERCE

Under the Paperwork Reduction Act of 1995, no persons are required to respond to a collection of information unless it displays a valid OMB control number.

POWER OF ATTORNEY TO PROSECUTE APPLICATIONS BEFORE THE USPTO

I hereby revoke all previous powers of attorney given in the application identified in the attached statement under 37 CFR 3.73(b).

I hereby appoint:

Practitioners associated with the Customer Number: 44367

OR

Practitioner(s) named below (if more than ten patent practitioners are to be named, then a customer number must be used).

Name	Registration Number	Name	Registration Number

as attorney(s) or agent(s) to represent the undersigned before the United States Patent and Trademark Office (USPTO) in connection with any and all patent applications assigned only to the undersigned according to the USPTO assignment records or assignment documents attached to this form in accordance with 37 CFR 3.73(b).

Please change the correspondence address for the application identified in the attached statement under 37 CFR 3.73(b) to:

The address associated with Customer Number: 44367

OR

<input type="checkbox"/> Firm or Individual Name			
Address			
City	State	Zip	
Country			
Telephone	Email		

Assignee Name and Address:
OpenTV, Inc.
275 Sacramento Street
San Francisco, CA 94111
United States of America

A copy of this form, together with a statement under 37 CFR 3.73(b) (Form PTO/SB/96 or equivalent) is required to be filed in each application in which this form is used. The statement under 37 CFR 3.73(b) may be completed by one of the practitioners appointed in this form if the appointed practitioner is authorized to act on behalf of the assignee, and must identify the application in which this Power of Attorney is to be filed.

SIGNATURE of Assignee of Record
The individual whose signature and title is supplied below is authorized to act on behalf of the assignee

Signature		Date: August 27, 2010
Name	Mark Beffault	Telephone: (415) 962-5000
Title	Senior Vice President Legal and IP	

Any comments on the amount of time you require to complete this form and/or suggestions for reducing this burden, should be sent to the Chief Information Officer, U.S. Patent and Trademark Office, U.S. Department of Commerce, P.O. Box 1450, Alexandria, VA 22313-1450. DO NOT SEND FEES OR COMPLETED FORMS TO THIS ADDRESS. SEND TO: Commissioner for Patents, P.O. Box 1450, Alexandria, VA 22313-1450.

RECEIVED
CENTRAL FAX CENTER

MAY 22 2012

MODIFIED PTO/SB/96 (07-09)

Approved for use through 07/31/2012. OMB 0651-0031

U.S. Patent and Trademark Office; U.S. DEPARTMENT OF COMMERCE

Under the Paperwork Reduction Act of 1995, no persons are required to respond to a collection of information unless it displays a valid OMB control number.

STATEMENT UNDER 37 C.F.R. 3.73(b)

Applicant/Patent Owner: Alain Delpuch et al. -Attorney Docket No. 2050.216US1
Application No./Patent No.: 10/419,621 -Filed/Issue Date: April 21, 2003
Titled: SUPPORTING COMMON INTERACTIVE TELEVISION FUNCTIONALITY THROUGH PRESENTATION ENGINE SYNTAX

OpenTV, Inc., a Corporation
(Name of Assignee) (Type of Assignee, e.g., corporation, partnership, university, government agency, etc.)

States that it is:

- 1. the assignee of the entire right, title, and interest in;
- 2. an assignee of less than the entire right, title, and interest in
(The extent (by percentage) of its ownership interest is _____ %); or
- 3. the assignee of an undivided interest in the entirety of (a complete assignment from one of the joint inventors was made)

the patent application/patent identified above, by virtue of either:

A. An assignment from the inventor(s) of the patent application/patent identified above. The assignment was recorded in the United States Patent and Trademark Office at Reel 014519, Frame 0695 - 0703, or for which a copy therefore is attached.

OR

B. A chain of title from the inventor(s), of the patent application/patent identified above, to the current assignee as follows:

- 1. From: _____ To: _____
The document was recorded in the United States Patent and Trademark Office at Reel _____, Frame _____, or for which a copy thereof is attached.
- 2. From: _____ To: _____
The document was recorded in the United States Patent and Trademark Office at Reel _____, Frame _____, or for which a copy thereof is attached.
- 3. From: _____ To: _____
The document was recorded in the United States Patent and Trademark Office at Reel _____, Frame _____, or for which a copy thereof is attached.

Additional documents in the chain of title are listed on a supplemental sheet(s).

As required by 37 CFR 3.73(b)(1)(i), the documentary evidence of the chain of title from the original owner to the assignee was, or concurrently is being, submitted for recordation pursuant to 37 CFR 3.11.
[NOTE: A separate copy (i.e., a true copy of the original assignment document(s)) must be submitted to Assignment Division in accordance with 37 CFR Part 3, to record the assignment in the records of the USPTO. See MPEP 302.08]

The undersigned (whose title is supplied below) is authorized to act on behalf of the assignee.

Signature *Garth Vivier* Date 5.21.2012

Garth Vivier USPTO Reg. No. 57,313
Printed or Typed Name Title

Any comments on the amount of time you require to complete this form and/or suggestions for reducing this burden, should be sent to the Chief Information Officer, U.S. Patent and Trademark Office, U.S. Department of Commerce, P.O. Box 1450, Alexandria, VA 22313-1450. DO NOT SEND FEES OR COMPLETED FORMS TO THIS ADDRESS. SEND TO: Commissioner for Patents, P.O. Box 1450, Alexandria, VA 22313-1450.

RECEIVED
CENTRAL FAX CENTER

MAY 22 2012



SCHWEGMAN • LUNDBERG • WOESSNER
PATENT PROTECTION FOR HIGH TECHNOLOGY

P.O. Box 2938
Minneapolis, MN 55402
Telephone (612) 373-6900 Facsimile (612) 339-3061

Date: 05/22/2012

Time: 11:04 AM
(Minneapolis, Minn.)

TO: Commissioner for Patents
Attn: Kieu Oanh T. (Krista) Bui
Patent Examining Corps
Facsimile Center
P.O. Box 1450
Alexandria, VA 22313-1450
FAX NUMBER 571-273-8300

FROM: Garth Vivier
OUR REF: 2050.216US1

* Please deliver to Examiner Kieu Oanh T. (Krista) Bui in Art Unit 2623. *

Document(s) Transmitted: **Power of Attorney to Prosecute Applications before the USPTO (PTO/SB/80) (1 pg.), Statement Under 37 C.F.R. 3.73(b) (PTO/SB/96) (1 pg.)**

Total pages of this transmission, including cover letter: 3

If you do NOT receive all of the pages described above, please telephone us at 612-373-6900 or fax us at 612-339-3061.

In re. Patent Application of: Alain Delpuch et al.

Examiner: Kieu Oanh T. (Krista) Bui

Serial No.: 10/419,621

Group Art Unit: 2623

Filed: April 21, 2003

Docket No.: 2050.216US1

Title: SUPPORTING COMMON INTERACTIVE TELEVISION FUNCTIONALITY THROUGH PRESENTATION ENGINE SYNTAX

Please charge any additional fees or credit overpayment to Deposit Account No. 19-0743.

By: *Garth Vivier*
Name: Garth Vivier
USPTO Reg. No. 57,313

I hereby certify that this paper is being transmitted by facsimile to the U.S. Patent and Trademark Office on the date shown below.

Mandy Brown
Mandy Brown

22 May 2012
Date of Transmission



UNITED STATES PATENT AND TRADEMARK OFFICE

UNITED STATES DEPARTMENT OF COMMERCE
United States Patent and Trademark Office
Address: COMMISSIONER FOR PATENTS
P.O. Box 1450
Alexandria, Virginia 22313-1450
www.uspto.gov

APPLICATION NUMBER	FILING OR 371(C) DATE	FIRST NAMED APPLICANT	ATTY. DOCKET NO./TITLE
10/419,621	04/21/2003	Alain Delpuch	2050.216US1

CONFIRMATION NO. 2305

POA ACCEPTANCE LETTER

44367
SCHWEGMAN, LUNDBERG & WOESSNER/OPEN TV
P.O. BOX 2938
MINNEAPOLIS, MN 55402-0938



Date Mailed: 06/04/2012

NOTICE OF ACCEPTANCE OF POWER OF ATTORNEY

This is in response to the Power of Attorney filed 05/22/2012.

The Power of Attorney in this application is accepted. Correspondence in this application will be mailed to the above address as provided by 37 CFR 1.33.

/zabraha/

Office of Data Management, Application Assistance Unit (571) 272-4000, or (571) 272-4200, or 1-888-786-0101



UNITED STATES PATENT AND TRADEMARK OFFICE

UNITED STATES DEPARTMENT OF COMMERCE
United States Patent and Trademark Office
Address: COMMISSIONER FOR PATENTS
P.O. Box 1450
Alexandria, Virginia 22313-1450
www.uspto.gov

APPLICATION NUMBER	FILING OR 371(C) DATE	FIRST NAMED APPLICANT	ATTY. DOCKET NO./TITLE
10/419,621	04/21/2003	Alain Delpuch	5266-06201

CONFIRMATION NO. 2305

POWER OF ATTORNEY NOTICE

44015
OPTV/MEYERTONS
MEYERTONS, HOOD, KIVLIN, KOWERT & GOETZEL, P.C.
P.O. BOX 398
AUSTIN, TX 78767-0398



Date Mailed: 06/04/2012

NOTICE REGARDING CHANGE OF POWER OF ATTORNEY

This is in response to the Power of Attorney filed 05/22/2012.

- The Power of Attorney to you in this application has been revoked by the assignee who has intervened as provided by 37 CFR 3.71. Future correspondence will be mailed to the new address of record(37 CFR 1.33).

/zabraha/

Office of Data Management, Application Assistance Unit (571) 272-4000, or (571) 272-4200, or 1-888-786-0101

AO 120 (Rev. 08/10)

TO: Mail Stop 8 Director of the U.S. Patent and Trademark Office P.O. Box 1450 Alexandria, VA 22313-1450	REPORT ON THE FILING OR DETERMINATION OF AN ACTION REGARDING A PATENT OR TRADEMARK
---	---

In Compliance with 35 U.S.C. § 290 and/or 15 U.S.C. § 1116 you are hereby advised that a court action has been filed in the U.S. District Court District of Delaware on the following

Trademarks or Patents. (the patent action involves 35 U.S.C. § 292.);

DOCKET NO.	DATE FILED 12/19/2012	U.S. DISTRICT COURT District of Delaware
PLAINTIFF OPENTV, INC.		DEFENDANT NETFLIX, INC.
PATENT OR TRADEMARK NO.	DATE OF PATENT OR TRADEMARK	HOLDER OF PATENT OR TRADEMARK
1 6,018,768	1/25/2000	OpenTV, Inc.
2 6,233,736 B1	5/15/2001	OpenTV, Inc.
3 7,055,169 B2	5/30/2006	OpenTV, Inc.
4 7,409,437 B2	8/5/2008	OpenTV, Inc.
5		See attachment for remaining patents

In the above—entitled case, the following patent(s)/ trademark(s) have been included:

DATE INCLUDED	INCLUDED BY <input type="checkbox"/> Amendment <input type="checkbox"/> Answer <input type="checkbox"/> Cross Bill <input type="checkbox"/> Other Pleading		
PATENT OR TRADEMARK NO.	DATE OF PATENT OR TRADEMARK	HOLDER OF PATENT OR TRADEMARK	
1			
2			
3			
4			
5			

In the above—entitled case, the following decision has been rendered or judgement issued:

DECISION/JUDGEMENT

CLERK	(BY) DEPUTY CLERK	DATE
-------	-------------------	------

<u>PATENT OR TRADEMARK NO.</u>	<u>DATE OF PATENT OR TRADEMARK</u>	<u>HOLDER OF PATENT OR TRADEMARK</u>
7,490,346 B2	2/10/2009	OpenTV, Inc.
7,949,722 B1	5/24/2011	OpenTV, Inc.
8,107,786	1/31/2012	OpenTV, Inc.

AO 120 (Rev. 2/99)

TO: Mail Stop 8 Director of the U.S. Patent & Trademark Office P.O. Box 1450 Alexandria, VA 22313-1450	REPORT ON THE FILING OR DETERMINATION OF AN ACTION REGARDING A PATENT OR TRADEMARK
---	--

In Compliance with 35 § 290 and/or 15 U.S.C. § 1116 you are hereby advised that a court action has been filed in the U.S. District Court Northern District California on the Patents or Trademarks:

DOCKET NO. CV 14-01525 RS	DATE FILED 4/2/14	U.S. DISTRICT COURT 450 Golden Gate Avenue, 16 th Floor, San Francisco CA 94102
PLAINTIFF OPENTV INC		DEFENDANT NETFLIX INC
PATENT OR TRADEMARK NO.	DATE OF PATENT OR TRADEMARK	HOLDER OF PATENT OR TRADEMARK
1 6,018,768		
2 6,233,734		
3 7,055,169		
4 7,409,437		
5 7,949,722		

In the above—entitled case, the following patent(s) have been included:

DATE INCLUDED	INCLUDED BY <input type="checkbox"/> Amendment <input type="checkbox"/> Answer <input type="checkbox"/> Cross Bill <input type="checkbox"/> Other Pleading	
PATENT OR TRADEMARK NO.	DATE OF PATENT OR TRADEMARK	HOLDER OF PATENT OR TRADEMARK
1 7,490,346		
2 8,107,786		
3		
4		
5		

In the above—entitled case, the following decision has been rendered or judgement issued:

DECISION/JUDGEMENT Stipulation and Order of Dismissal was efiled on 2/11/15.

CLERK Richard W. Wieking	(BY) DEPUTY CLERK Gina Augustine	DATE February 12, 2015
---------------------------------	---	-------------------------------

Copy 1—Upon initiation of action, mail this copy to Commissioner Copy 3—Upon termination of action, mail this copy to Commissioner
 Copy 2—Upon filing document adding patent(s), mail this copy to Commissioner Copy 4—Case file copy

Russell E. Levine, P.C. (pro hac vice)
rlevine@kirkland.com
Paul D. Collier (pro hac vice)
pcollier@kirkland.com
James B. Medek (pro hac vice)
jmedek@kirkland.com
Greg Polins (pro hac vice)
greg.polins@kirkland.com
George William Foster (pro hac vice)
billy.foster@kirkland.com
KIRKLAND & ELLIS LLP
300 North LaSalle Street
Chicago, IL 60654
Telephone: (312) 862-2000
Facsimile: (312) 862-2200

DURIE TANGRI LLP
DARALYN J. DURIE (SBN 169825)
ddurie@durietangri.com
CLEMENT S. ROBERTS (SBN 209203)
croberts@durietangri.com
LAURA E. MILLER (SBN 271713)
lmiller@durietangri.com
ZAC A. COX (SBN 283535)
zcox@durietangri.com
217 Leidesdorff Street
San Francisco, CA 94111
Telephone: (415) 362-6666
Facsimile: (415) 236-6300

Attorneys for Defendant
NETFLIX, INC.

John R. Edwards (S.B.N. 244310)
john.edwards@kirkland.com
Brian W. Lee (S.B.N. 255363)
brian.lee@kirkland.com
Mark D. Fahey (S.B.N. 294551)
mark.fahey@kirkland.com
KIRKLAND & ELLIS LLP
3330 Hillview Avenue
Palo Alto, CA 94304
Telephone: (650) 859-7000
Facsimile: (650) 859-7500

Attorneys for Plaintiffs OpenTV, Inc. and
Nagra France SAS

ECF DOCUMENT

I hereby attest and certify this is a printed copy of a
document which was electronically filed with the United States
District Court for the Northern District of California.

Date Filed: 2/11/15

RICHARD W. WIEKING, Clerk

By: GINA AGUSTINE, Deputy Clerk

**UNITED STATES DISTRICT COURT
NORTHERN DISTRICT OF CALIFORNIA
SAN FRANCISCO DIVISION**

OPENTV, INC.,

Plaintiff,

v.

NETFLIX, INC.,

Defendant.

Case No. 3:14-cv-01525-RS
Case No. 3:14-cv-01723-RS

**AMENDED STIPULATION AND JOINT
MOTION TO DISMISS WITHOUT
PREJUDICE AND [PROPOSED] ORDER**

**OPENTV, INC. and NAGRA FRANCE
SAS,**

Plaintiffs,

v.

NETFLIX, INC.,

Defendant.

Judge: Hon. Richard Seeborg

AMENDED STIPULATED AND JOINT MOTION
TO DISMISS AND [PROPOSED] ORDER

3:14-cv-01525
3:14-cv-01723

1 Plaintiffs OpenTV, Inc. and Nagra France SAS (collectively "OpenTV") and Defendant Netflix,
2 Inc. ("Netflix") hereby stipulate and request that the Court order as follows:

3 1. All claims between OpenTV and Netflix, including all claims presented by OpenTV's
4 Complaints and all of Netflix's Counterclaims, shall be dismissed without prejudice; and

5 2. OpenTV and Netflix each shall bear their own costs and attorneys' fees.

6 Dated: February 11, 2015

/s/ John R. Edwards

7 _____
Counsel for Plaintiffs

8
9
10 Dated: February 11, 2015

/s/ Laura E. Miller

11 _____
Counsel for Defendant

12 PURSUANT TO STIPULATION, IT IS SO ORDERED.

13
14 Dated: 2/11/2015



Richard Seeborg
United States District Judge

AO 120 (Rev. 08/10)

TO: Mail Stop 8 Director of the U.S. Patent and Trademark Office P.O. Box 1450 Alexandria, VA 22313-1450	REPORT ON THE FILING OR DETERMINATION OF AN ACTION REGARDING A PATENT OR TRADEMARK
---	---

In Compliance with 35 U.S.C. § 290 and/or 15 U.S.C. § 1116 you are hereby advised that a court action has been filed in the U.S. District Court for the Eastern District of Texas on the following
 Trademarks or Patents. (the patent action involves 35 U.S.C. § 292.);

DOCKET NO. 6:15-cv-951	DATE FILED 10/30/2015	U.S. DISTRICT COURT for the Eastern District of Texas
PLAINTIFF OpenTV, Inc. and Nagra France S.A.S.		DEFENDANT Verizon Communications Inc. et al
PATENT OR TRADEMARK NO.	DATE OF PATENT OR TRADEMARK	HOLDER OF PATENT OR TRADEMARK
1 7,055,169	5/30/2006	OpenTV, Inc.
2 7,243,139	7/10/2007	OpenTV, Inc.
3 RE40,334	5/20/2008	Nagra France S.A.S.
4 7,900,229	3/1/2011	OpenTV, Inc.
5 6,678,463	1/13/2004	OPenTV, Inc.

In the above—entitled case, the following patent(s)/ trademark(s) have been included:

DATE INCLUDED	INCLUDED BY	
	<input type="checkbox"/> Amendment <input type="checkbox"/> Answer <input type="checkbox"/> Cross Bill <input type="checkbox"/> Other Pleading	
PATENT OR TRADEMARK NO.	DATE OF PATENT OR TRADEMARK	HOLDER OF PATENT OR TRADEMARK
1		
2		
3		
4		
5		

In the above—entitled case, the following decision has been rendered or judgement issued:

DECISION/JUDGEMENT

CLERK	(BY) DEPUTY CLERK	DATE
-------	-------------------	------

Copy 1—Upon initiation of action, mail this copy to Director Copy 3—Upon termination of action, mail this copy to Director
 Copy 2—Upon filing document adding patent(s), mail this copy to Director Copy 4—Case file copy

AO 120 (Rev. 08/10)

TO: Mail Stop 8 Director of the U.S. Patent and Trademark Office P.O. Box 1450 Alexandria, VA 22313-1450	REPORT ON THE FILING OR DETERMINATION OF AN ACTION REGARDING A PATENT OR TRADEMARK
---	---

In Compliance with 35 U.S.C. § 290 and/or 15 U.S.C. § 1116 you are hereby advised that a court action has been filed in the U.S. District Court _____ for the Eastern District of Texas _____ on the following

Trademarks or Patents. (the patent action involves 35 U.S.C. § 292.):

DOCKET NO. 6:15-cv-951	DATE FILED 10/30/2015	U.S. DISTRICT COURT for the Eastern District of Texas
PLAINTIFF OpenTV, Inc. and Nagra France S.A.S.		DEFENDANT Verizon Communications Inc. et al
PATENT OR TRADEMARK NO.	DATE OF PATENT OR TRADEMARK	HOLDER OF PATENT OR TRADEMARK
1 6,233,736	5/15/2001	OpenTV, Inc.
2 6,018,768	1/25/0200	OpenTV, Inc.
3		
4		
5		

In the above—entitled case, the following patent(s)/ trademark(s) have been included:

DATE INCLUDED	INCLUDED BY <input type="checkbox"/> Amendment <input type="checkbox"/> Answer <input type="checkbox"/> Cross Bill <input type="checkbox"/> Other Pleading		
PATENT OR TRADEMARK NO.	DATE OF PATENT OR TRADEMARK	HOLDER OF PATENT OR TRADEMARK	
1			
2			
3			
4			
5			

In the above—entitled case, the following decision has been rendered or judgement issued:

DECISION/JUDGEMENT

CLERK	(BY) DEPUTY CLERK	DATE
-------	-------------------	------

Copy 1—Upon initiation of action, mail this copy to Director Copy 3—Upon termination of action, mail this copy to Director
 Copy 2—Upon filing document adding patent(s), mail this copy to Director Copy 4—Case file copy

AO 120 (Rev. 08/10)

TO: Mail Stop 8 Director of the U.S. Patent and Trademark Office P.O. Box 1450 Alexandria, VA 22313-1450	REPORT ON THE FILING OR DETERMINATION OF AN ACTION REGARDING A PATENT OR TRADEMARK
---	---

In Compliance with 35 U.S.C. § 290 and/or 15 U.S.C. § 1116 you are hereby advised that a court action has been filed in the U.S. District Court EASTERN DISTRICT OF TEXAS, MARSHALL DIVISION on the following
 Trademarks or Patents. (the patent action involves 35 U.S.C. § 292.):

DOCKET NO. 2:15-cv-1725	DATE FILED 11/6/2015	U.S. DISTRICT COURT EASTERN DISTRICT OF TEXAS, MARSHALL DIVISION
PLAINTIFF FREE STREAM MEDIA CORP. D/B/A SAMBA TV 528 FOLSOM STREET SAN FRANCISCO, CA 94105		DEFENDANT ALPHONSO INC. 224 W. 35TH STREET, 11TH FLOOR NEW YORK, NEW YORK 10001
PATENT OR TRADEMARK NO.	DATE OF PATENT OR TRADEMARK	HOLDER OF PATENT OR TRADEMARK
1 U.S. 9,026,668	5/5/2015	FREE STREAM MEDIA CORP.
2		
3		
4		
5		

In the above—entitled case, the following patent(s)/ trademark(s) have been included:

DATE INCLUDED	INCLUDED BY <input type="checkbox"/> Amendment <input type="checkbox"/> Answer <input type="checkbox"/> Cross Bill <input type="checkbox"/> Other Pleading		
PATENT OR TRADEMARK NO.	DATE OF PATENT OR TRADEMARK	HOLDER OF PATENT OR TRADEMARK	
1			
2			
3			
4			
5			

In the above—entitled case, the following decision has been rendered or judgement issued:

DECISION/JUDGEMENT

CLERK	(BY) DEPUTY CLERK	DATE
-------	-------------------	------

Copy 1—Upon initiation of action, mail this copy to Director Copy 3—Upon termination of action, mail this copy to Director
 Copy 2—Upon filing document adding patent(s), mail this copy to Director Copy 4—Case file copy

UNITED STATES PATENT AND TRADEMARK OFFICE

BEFORE THE PATENT TRIAL AND APPEAL BOARD

APPLE INC.,
Petitioner,

v.

OPENTV, INC.,
Patent Owner.

Case CBM2016-00066
Patent 7,055,169 B2

Before JAMESON LEE, SALLY C. MEDLEY, and
MICHAEL R. ZECHER, *Administrative Patent Judges*.

ZECHER, *Administrative Patent Judge*.

JUDGMENT

Granting Joint Motion to Terminate Proceeding and
Granting Request to Treat Agreements as Business Confidential Information
37 C.F.R. §§ 42.72 and 42.74

I. INTRODUCTION

On August 4, 2016, the parties filed a Joint Motion to Terminate Proceeding (Paper 7, “Mot.”), and a joint request to treat the settlement agreements as business confidential information under 35 U.S.C. § 317(b) and 37 C.F.R. § 42.74(c) (Paper 8). A conference call was held on August 9, 2016, and we issued an Order on August 10, 2016 (Paper 11) instructing the parties that they reduce to writing any agreement or understanding between them in contemplation of termination. We observed that none of the agreements filed by the parties on August 4, 2016, i.e., Exhibits 1011, 2001, 2002, 2003, and 2004, reflects any understanding between the Petitioner and the Patent Owner. Paper 11, 2. We also observed that Exhibits 2001 and 2002 appear to be incomplete. *Id.* at 2–3.

On August 19, 2016, the parties filed Exhibit 2005, which is a writing reflecting an understanding between the Petitioner and Patent Owner in contemplation of termination of proceeding, and a joint request to treat this exhibit as confidential business information under 37 C.F.R. § 42.74(c) (Paper 13). Also on August 17, 2016, the parties filed replacement copies of Exhibits 2001 and 2002. Further on August 17, 2016, Patent Owner filed an updated Mandatory Notice to identify its parent entities and to list additional real parties in interest. Paper 12.

II. DISCUSSION

The parties represent in the Joint Motion to Terminate Proceeding that the filed agreements “end all patent disputes between the parties, including this proceeding.” Mot. 6. The parties also indicate that all related district

court cases involving U.S. Patent No. 7,055,169 B2 have either been dismissed or are subject to pending joint motions to terminate. *Id.* at 3–6.

This proceeding is still in a preliminary stage. Patent Owner has yet to file a Preliminary Response and we have yet to decide whether to institute a trial. Under the circumstances presented here, we determine that it is appropriate to terminate this proceeding with respect to both Petitioner and Patent Owner without rendering any further decisions. *See* 37 C.F.R. § 42.72.

III. ORDER

In consideration of the foregoing, it is hereby

ORDERED that the parties' Joint Motion to Terminate Proceeding, both as to Petitioner and Patent Owner, is *granted*;

FURTHER ORDERED that the parties' joint request (Paper 8) to treat Exhibits 1011, 2001, 2002, 2003, and 2004 as business confidential information under 35 U.S.C. § 317(b) and 37 C.F.R. § 42.74(c) is *granted*;

FURTHER ORDERED that the parties' joint request (Paper 13) to treat Exhibit 2005 as business confidential information under 35 U.S.C. § 317(b) and 37 C.F.R. § 42.74(c) is *granted*;

FURTHER ORDERED that the parties' request to accept the filing of Exhibits 1011 and 2002 under the access category of "available only to Board" in the Board's electronic filing system is *granted*;¹ and

FURTHER ORDERED that this proceeding is terminated with respect to both Petitioner and Patent Owner.

¹ See Paper 11, 3.

CBM2016-00066
Patent 7,055,169 B2

For PETITIONER:

Mark E. Miller
Ryan K. Yagura
Anne E. Huffsmith
Brian M. Cook
Xin-Yi Zhou
John Kevin Murray
Laura Bayne
O'Melveny & Myers LLP
markmiller@omm.com
ryagura@omm.com
ahuffsmith@omm.com
bcook@omm.com
vzhou@omm.com
kmurray2@omm.com
lbayne@omm.com

For PATENT OWNER:

Joshua L. Goldberg
Daniel G. Chung
Erika H. Arner
Finnegan, Henderson, Farabow, Garrett & Dunner, LLP
joshua.goldberg@finnegan.com
daniel.chung@finnegan.com
erika.arnier@finnegan.com

UNITED STATES PATENT AND TRADEMARK OFFICE

BEFORE THE PATENT TRIAL AND APPEAL BOARD

APPLE INC.,
Petitioner,

v.

OPENTV, INC.,
Patent Owner.

Case IPR2016-01004
Patent 7,055,169 B2

Before JAMESON LEE, SALLY C. MEDLEY, and
MICHAEL R. ZECHER, *Administrative Patent Judges*.

ZECHER, *Administrative Patent Judge*.

JUDGMENT

Granting Joint Motion to Terminate Proceeding and
Granting Request to Treat Agreements as Business Confidential Information
37 C.F.R. §§ 42.72 and 42.74

I. INTRODUCTION

On August 4, 2016, the parties filed a Joint Motion to Terminate Proceeding (Paper 8, “Mot.”), and a joint request to treat the settlement agreements as business confidential information under 35 U.S.C. § 317(b) and 37 C.F.R. § 42.74(c) (Paper 9). A conference call was held on August 9, 2016, and we issued an Order on August 10, 2016 (Paper 11) instructing the parties that they reduce to writing any agreement or understanding between them in contemplation of termination. We observed that none of the agreements filed by the parties on August 4, 2016, i.e., Exhibits 1117, 2001, 2002, 2003, and 2004, reflects any understanding between the Petitioner and the Patent Owner. Paper 11, 2. We also observed that Exhibits 2001 and 2002 appear to be incomplete. *Id.* at 2–3.

On August 19, 2016, the parties filed Exhibit 2005, which is a writing reflecting an understanding between the Petitioner and Patent Owner in contemplation of termination of proceeding, and a joint request to treat this exhibit as confidential business information under 37 C.F.R. § 42.74(c) (Paper 13). Also on August 17, 2016, the parties filed replacement copies of Exhibits 2001 and 2002. Further on August 17, 2016, Patent Owner filed an updated Mandatory Notice to identify its parent entities and to list additional real parties in interest. Paper 12.

II. DISCUSSION

The parties represent in the Joint Motion to Terminate Proceeding that the filed agreements “end all patent disputes between the parties, including this proceeding.” Mot. 6. The parties also indicate that all related district

court cases involving U.S. Patent No. 7,055,169 B2 have either been dismissed or are subject to pending joint motions to terminate. *Id.* at 3–6.

This proceeding is still in a preliminary stage. Patent Owner has yet to file a Preliminary Response and we have yet to decide whether to institute a trial. Under the circumstances presented here, we determine that it is appropriate to terminate this proceeding with respect to both Petitioner and Patent Owner without rendering any further decisions. *See* 37 C.F.R. § 42.72.

III. ORDER

In consideration of the foregoing, it is hereby

ORDERED that the parties' Joint Motion to Terminate Proceeding, both as to Petitioner and Patent Owner, is *granted*;

FURTHER ORDERED that the parties' joint request (Paper 9) to treat Exhibits 1117, 2001, 2002, 2003, and 2004 as business confidential information under 35 U.S.C. § 317(b) and 37 C.F.R. § 42.74(c) is *granted*;

FURTHER ORDERED that the parties' joint request (Paper 13) to treat Exhibit 2005 as business confidential information under 35 U.S.C. § 317(b) and 37 C.F.R. § 42.74(c) is *granted*;

FURTHER ORDERED that the parties' request to accept the filing of Exhibits 1117 and 2002 under the access category of "available only to Board" in the Board's electronic filing system is *granted*;¹ and

FURTHER ORDERED that this proceeding is terminated with respect to both Petitioner and Patent Owner.

¹ *See* Paper 11, 3.

IPR2016-01004
Patent 7,055,169 B2

For PETITIONER:

Mark E. Miller
Ryan K. Yagura
Anne E. Huffsmith
Brian M. Cook
Xin-Yi Zhou
John Kevin Murray
Laura Bayne
O'Melveny & Myers LLP
markmiller@omm.com
ryagura@omm.com
ahuffsmith@omm.com
bcook@omm.com
vzhou@omm.com
kmurray2@omm.com
lbayne@omm.com

For PATENT OWNER:

Joshua L. Goldberg
Daniel G. Chung
Erika H. Arner
Finnegan, Henderson, Farabow, Garrett & Dunner, LLP
joshua.goldberg@finnegan.com
daniel.chung@finnegan.com
erika.arnier@finnegan.com

AO 120 (Rev. 08/10)

TO: Mail Stop 8 Director of the U.S. Patent and Trademark Office P.O. Box 1450 Alexandria, VA 22313-1450	REPORT ON THE FILING OR DETERMINATION OF AN ACTION REGARDING A PATENT OR TRADEMARK
---	---

In Compliance with 35 U.S.C. § 290 and/or 15 U.S.C. § 1116 you are hereby advised that a court action has been filed in the U.S. District Court _____ for the Eastern District of Texas _____ on the following

Trademarks or Patents. (the patent action involves 35 U.S.C. § 292.):

DOCKET NO. 2:17-cv-31	DATE FILED 1/12/2017	U.S. DISTRICT COURT for the Eastern District of Texas
PLAINTIFF OpenTV, Inc.		DEFENDANT NFL Enterprises, LLC
PATENT OR TRADEMARK NO.	DATE OF PATENT OR TRADEMARK	HOLDER OF PATENT OR TRADEMARK
1 7,996,861	8/9/2011	OpenTV, Inc.
2 7,421,729	9/2/2008	OpenTV, Inc.
3 7,028,327	4/11/2006	OpenTV, Inc.
4 7,950,033	5/24/2011	OpenTV, Inc.
5 7,055,169	5/30/2006	OPenTV, Inc.

In the above—entitled case, the following patent(s)/ trademark(s) have been included:

DATE INCLUDED	INCLUDED BY <input type="checkbox"/> Amendment <input type="checkbox"/> Answer <input type="checkbox"/> Cross Bill <input type="checkbox"/> Other Pleading	
PATENT OR TRADEMARK NO.	DATE OF PATENT OR TRADEMARK	HOLDER OF PATENT OR TRADEMARK
1		
2		
3		
4		
5		

In the above—entitled case, the following decision has been rendered or judgement issued:

DECISION/JUDGEMENT

CLERK	(BY) DEPUTY CLERK	DATE
-------	-------------------	------

Copy 1—Upon initiation of action, mail this copy to Director Copy 3—Upon termination of action, mail this copy to Director
 Copy 2—Upon filing document adding patent(s), mail this copy to Director Copy 4—Case file copy

AO 120 (Rev. 08/10)

TO: Mail Stop 8 Director of the U.S. Patent and Trademark Office P.O. Box 1450 Alexandria, VA 22313-1450	REPORT ON THE FILING OR DETERMINATION OF AN ACTION REGARDING A PATENT OR TRADEMARK
---	---

In Compliance with 35 U.S.C. § 290 and/or 15 U.S.C. § 1116 you are hereby advised that a court action has been filed in the U.S. District Court _____ for the Eastern District of Texas _____ on the following

Trademarks or Patents. (the patent action involves 35 U.S.C. § 292.):

DOCKET NO. 2:17-cv-31	DATE FILED 1/12/2017	U.S. DISTRICT COURT for the Eastern District of Texas
PLAINTIFF OpenTV, Inc.		DEFENDANT NFL Enterprises, LLC
PATENT OR TRADEMARK NO.	DATE OF PATENT OR TRADEMARK	HOLDER OF PATENT OR TRADEMARK
1 7,020,888	3/28/2006	OpenTV, Inc.
2 6,233,736	5/15/2001	OpenTV, Inc.
3		
4		
5		

In the above—entitled case, the following patent(s)/ trademark(s) have been included:

DATE INCLUDED	INCLUDED BY <input type="checkbox"/> Amendment <input type="checkbox"/> Answer <input type="checkbox"/> Cross Bill <input type="checkbox"/> Other Pleading	
PATENT OR TRADEMARK NO.	DATE OF PATENT OR TRADEMARK	HOLDER OF PATENT OR TRADEMARK
1		
2		
3		
4		
5		

In the above—entitled case, the following decision has been rendered or judgement issued:

DECISION/JUDGEMENT

CLERK	(BY) DEPUTY CLERK	DATE
-------	-------------------	------

Copy 1—Upon initiation of action, mail this copy to Director Copy 3—Upon termination of action, mail this copy to Director
 Copy 2—Upon filing document adding patent(s), mail this copy to Director Copy 4—Case file copy

TO: Mail Stop 8
 Director of the U.S. Patent & Trademark Office
 P.O. Box 1450
 Alexandria, VA 22313-1450

**REPORT ON THE
 FILING OR DETERMINATION OF AN
 ACTION REGARDING A PATENT OR
 TRADEMARK**

In Compliance with 35 § 290 and/or 15 U.S.C. § 1116 you are hereby advised that a court action has been filed in the U.S. District Court NDCA on the following:

(X) Patents or () Trademarks

DOCKET NO:
 16-cv-02433-DMR

DATE FILED:
 May 4, 2016

UNITED STATES DISTRICT COURT
 Ronald Dellums Federal Building
 1301 Clay Street
 Oakland, CA 94612

PLAINTIFF:
 Time Warner Cable Inc.

DEFENDANT:
 OpenTV, Inc.

PATENT OR TRADEMARK NO.	DATE OF PATENT OR TRADEMARK	HOLDER OF PATENT OR TRADEMARK
1. 5907322		**SEE ATTACHMENT
2. 6530082		
3. 6678463		
4. 6895595		
5. 6985586		

In the above-entitled case, the following patent(s) have been included.

DATE INCLUDED INCLUDED BY:
 () Amendment () Answer () Cross Bill () Other Pleading

PATENT OR TRADEMARK NO.	DATE OF PATENT OR TRADEMARK	HOLDER OF PATENT OR TRADEMARK
1. 7055169		
2. 7243139		
3. 7536704		
4. 7669212		
5.		

In the above-entitled case, the following decision has been rendered or judgment issued:

DECISION/JUDGEMENT:

Susan Y. Soong
 Susan Y. Soong, Clerk

V Kyono
 (by) Deputy Clerk, Valerie Kyono

- Copy 1 – Upon initiation of action, mail this copy to Commissioner
- Copy 2 – Upon filing document adding patent(s) mail this copy to Commissioner
- Copy 3 – Upon termination of action, mail this copy to the Commissioner
- Copy 4 – Case file copy

TO: Mail Stop 8 Director of the U.S. Patent and Trademark Office P.O. Box 1450 Alexandria, VA 22313-1450	REPORT ON THE FILING OR DETERMINATION OF AN ACTION REGARDING A PATENT OR TRADEMARK
---	---

In Compliance with 35 U.S.C. § 290 and/or 15 U.S.C. § 1116 you are hereby advised that a court action has been filed in the U.S. District Court for the Eastern District of Texas on the following

Trademarks or Patents. (the patent action involves 35 U.S.C. § 292.):

DOCKET NO. 6:15-cv-951	DATE FILED 10/30/2015	U.S. DISTRICT COURT for the Eastern District of Texas
PLAINTIFF OpenTV, Inc. and Nagra France S.A.S.		DEFENDANT Verizon Communications Inc. et al
PATENT OR TRADEMARK NO.	DATE OF PATENT OR TRADEMARK	HOLDER OF PATENT OR TRADEMARK
1 7,055,169	5/30/2006	OpenTV, Inc.
2 7,243,139	7/10/2007	OpenTV, Inc.
3 RE40,334	5/20/2008	Nagra France S.A.S.
4 7,900,229	3/1/2011	OpenTV, Inc.
5 6,678,463	1/13/2004	OPenTV, Inc.

In the above—entitled case, the following patent(s)/ trademark(s) have been included:

DATE INCLUDED	INCLUDED BY <input type="checkbox"/> Amendment <input type="checkbox"/> Answer <input type="checkbox"/> Cross Bill <input type="checkbox"/> Other Pleading
PATENT OR TRADEMARK NO.	DATE OF PATENT OR TRADEMARK HOLDER OF PATENT OR TRADEMARK
1	
2	
3	
4	
5	

In the above—entitled case, the following decision has been rendered or judgement issued:

DECISION/JUDGEMENT
ORDER DISMISSING CASE. All of Plaintiffs' claims against Defendants are hereby dismissed with prejudice. All attorneys' fees, costs of court and expenses shall be borne by each party incurring the same.

CLERK David A O'Toole	(BY) DEPUTY CLERK Michael Lantz	DATE 03/17/2016
--------------------------	------------------------------------	--------------------

Copy 1—Upon initiation of action, mail this copy to Director Copy 3—Upon termination of action, mail this copy to Director
 Copy 2—Upon filing document adding patent(s), mail this copy to Director Copy 4—Case file copy

TO: Mail Stop 8 Director of the U.S. Patent and Trademark Office P.O. Box 1450 Alexandria, VA 22313-1450	REPORT ON THE FILING OR DETERMINATION OF AN ACTION REGARDING A PATENT OR TRADEMARK
---	---

In Compliance with 35 U.S.C. § 290 and/or 15 U.S.C. § 1116 you are hereby advised that a court action has been filed in the U.S. District Court _____ for the Eastern District of Texas _____ on the following

Trademarks or Patents. (the patent action involves 35 U.S.C. § 292.):

DOCKET NO. 6:15-cv-951	DATE FILED 10/30/2015	U.S. DISTRICT COURT for the Eastern District of Texas
PLAINTIFF OpenTV, Inc. and Nagra France S.A.S.		DEFENDANT Verizon Communications Inc. et al
PATENT OR TRADEMARK NO.	DATE OF PATENT OR TRADEMARK	HOLDER OF PATENT OR TRADEMARK
1 7,055,169	5/30/2006	OpenTV, Inc.
2 7,243,139	7/10/2007	OpenTV, Inc.
3 RE40,334	5/20/2008	Nagra France S.A.S.
4 7,900,229	3/1/2011	OpenTV, Inc.
5 6,678,463	1/13/2004	OPenTV, Inc.

In the above—entitled case, the following patent(s)/ trademark(s) have been included:

DATE INCLUDED	INCLUDED BY <input type="checkbox"/> Amendment <input type="checkbox"/> Answer <input type="checkbox"/> Cross Bill <input type="checkbox"/> Other Pleading	
PATENT OR TRADEMARK NO.	DATE OF PATENT OR TRADEMARK	HOLDER OF PATENT OR TRADEMARK
1		
2		
3		
4		
5		

In the above—entitled case, the following decision has been rendered or judgement issued:

DECISION/JUDGEMENT
ORDER DISMISSING CASE. All of Plaintiffs' claims against Defendants are hereby dismissed with prejudice. All attorneys' fees, costs of court and expenses shall be borne by each party incurring the same.

CLERK David A O'Toole	(BY) DEPUTY CLERK Michael Lantz	DATE 03/17/2016
--------------------------	------------------------------------	--------------------

Copy 1—Upon initiation of action, mail this copy to Director Copy 3—Upon termination of action, mail this copy to Director
 Copy 2—Upon filing document adding patent(s), mail this copy to Director Copy 4—Case file copy

TO: Mail Stop 8 Director of the U.S. Patent and Trademark Office P.O. Box 1450 Alexandria, VA 22313-1450	REPORT ON THE FILING OR DETERMINATION OF AN ACTION REGARDING A PATENT OR TRADEMARK
---	---

In Compliance with 35 U.S.C. § 290 and/or 15 U.S.C. § 1116 you are hereby advised that a court action has been filed in the U.S. District Court _____ for the Eastern District of Texas _____ on the following

Trademarks or Patents. (the patent action involves 35 U.S.C. § 292.):

DOCKET NO. 6:15-cv-951	DATE FILED 10/30/2015	U.S. DISTRICT COURT for the Eastern District of Texas
PLAINTIFF OpenTV, Inc. and Nagra France S.A.S.		DEFENDANT Verizon Communications Inc. et al
PATENT OR TRADEMARK NO.	DATE OF PATENT OR TRADEMARK	HOLDER OF PATENT OR TRADEMARK
1 6,233,736	5/15/2001	OpenTV, Inc.
2 6,018,768	1/25/0200	OpenTV, Inc.
3		
4		
5		

In the above—entitled case, the following patent(s)/ trademark(s) have been included:

DATE INCLUDED	INCLUDED BY <input type="checkbox"/> Amendment <input type="checkbox"/> Answer <input type="checkbox"/> Cross Bill <input type="checkbox"/> Other Pleading	
PATENT OR TRADEMARK NO.	DATE OF PATENT OR TRADEMARK	HOLDER OF PATENT OR TRADEMARK
1		
2		
3		
4		
5		

In the above—entitled case, the following decision has been rendered or judgement issued:

DECISION/JUDGEMENT
ORDER DISMISSING CASE. All of Plaintiffs' claims against Defendants are hereby dismissed with prejudice. All attorneys' fees, costs of court and expenses shall be borne by each party incurring the same.

CLERK David A O'Toole	(BY) DEPUTY CLERK Michael Lantz	DATE 03/17/2016
--------------------------	------------------------------------	--------------------

Copy 1—Upon initiation of action, mail this copy to Director Copy 3—Upon termination of action, mail this copy to Director
 Copy 2—Upon filing document adding patent(s), mail this copy to Director Copy 4—Case file copy

AO 120 (Rev. 08/10)

TO: Mail Stop 8 Director of the U.S. Patent and Trademark Office P.O. Box 1450 Alexandria, VA 22313-1450	REPORT ON THE FILING OR DETERMINATION OF AN ACTION REGARDING A PATENT OR TRADEMARK
---	---

In Compliance with 35 U.S.C. § 290 and/or 15 U.S.C. § 1116 you are hereby advised that a court action has been filed in the U.S. District Court _____ for the Eastern District of Texas _____ on the following

Trademarks or Patents. (the patent action involves 35 U.S.C. § 292.):

DOCKET NO. 2:17-cv-31	DATE FILED 1/12/2017	U.S. DISTRICT COURT for the Eastern District of Texas
PLAINTIFF OpenTV, Inc.		DEFENDANT NFL Enterprises, LLC
PATENT OR TRADEMARK NO.	DATE OF PATENT OR TRADEMARK	HOLDER OF PATENT OR TRADEMARK
1 7,996,861	8/9/2011	OpenTV, Inc.
2 7,421,729	9/2/2008	OpenTV, Inc.
3 7,028,327	4/11/2006	OpenTV, Inc.
4 7,950,033	5/24/2011	OpenTV, Inc.
5 7,055,169	5/30/2006	OPenTV, Inc.

In the above—entitled case, the following patent(s)/ trademark(s) have been included:

DATE INCLUDED	INCLUDED BY <input type="checkbox"/> Amendment <input type="checkbox"/> Answer <input type="checkbox"/> Cross Bill <input type="checkbox"/> Other Pleading	
PATENT OR TRADEMARK NO.	DATE OF PATENT OR TRADEMARK	HOLDER OF PATENT OR TRADEMARK
1		
2		
3		
4		
5		

In the above—entitled case, the following decision has been rendered or judgement issued:

DECISION/JUDGEMENT <p style="text-align: center;">The Court hereby dismisses all claims against Defendant NFL Enterprises, LLC, without prejudice in accordance with Fed. R. Civ. P. 41(a)(1).</p>

CLERK <i>David A. O'Poole</i>	(BY) DEPUTY CLERK Sonja Oliver	DATE 5/31/17
----------------------------------	-----------------------------------	------------------------

Copy 1—Upon initiation of action, mail this copy to Director Copy 3—Upon termination of action, mail this copy to Director
 Copy 2—Upon filing document adding patent(s), mail this copy to Director Copy 4—Case file copy

AO 120 (Rev. 08/10)

TO: Mail Stop 8 Director of the U.S. Patent and Trademark Office P.O. Box 1450 Alexandria, VA 22313-1450	REPORT ON THE FILING OR DETERMINATION OF AN ACTION REGARDING A PATENT OR TRADEMARK
---	---

In Compliance with 35 U.S.C. § 290 and/or 15 U.S.C. § 1116 you are hereby advised that a court action has been filed in the U.S. District Court _____ for the Eastern District of Texas _____ on the following

Trademarks or Patents. (the patent action involves 35 U.S.C. § 292.):

DOCKET NO. 2:17-cv-31	DATE FILED 1/12/2017	U.S. DISTRICT COURT for the Eastern District of Texas
PLAINTIFF OpenTV, Inc.		DEFENDANT NFL Enterprises, LLC
PATENT OR TRADEMARK NO.	DATE OF PATENT OR TRADEMARK	HOLDER OF PATENT OR TRADEMARK
1 7,020,888	3/28/2006	OpenTV, Inc.
2 6,233,736	5/15/2001	OpenTV, Inc.
3		
4		
5		

In the above—entitled case, the following patent(s)/ trademark(s) have been included:

DATE INCLUDED	INCLUDED BY <input type="checkbox"/> Amendment <input type="checkbox"/> Answer <input type="checkbox"/> Cross Bill <input type="checkbox"/> Other Pleading	
PATENT OR TRADEMARK NO.	DATE OF PATENT OR TRADEMARK	HOLDER OF PATENT OR TRADEMARK
1		
2		
3		
4		
5		

In the above—entitled case, the following decision has been rendered or judgement issued:

DECISION/JUDGEMENT

CLERK	(BY) DEPUTY CLERK	DATE
-------	-------------------	------

Copy 1—Upon initiation of action, mail this copy to Director Copy 3—Upon termination of action, mail this copy to Director
 Copy 2—Upon filing document adding patent(s), mail this copy to Director Copy 4—Case file copy