

DESIGN NOTES

A Miniature, Low Dropout Battery Charger for Lithium-Ion Batteries – Design Note 239

James Herr

INTRODUCTION

Lithium-ion (Li-Ion) batteries are becoming the power source of choice for today's small handheld electronic devices due to their light weight and high energy density. However, there are a number of important issues associated with the charging of these batteries. As an example, if they are overcharged, they can be potentially hazardous to the user.

The LTC[®]1731 is a constant-current/constant-voltage linear charger controller for single cell lithium-ion batteries. Its output accuracy of $\pm 1\%$ (max) over the -40°C to 85°C range prevents the possibility of overcharging. The output float potential is internally set to either 4.1V or 4.2V, without the use of an expensive external 0.1% resistor divider. Furthermore, the charging current is user programmable with $\pm 7\%$ accuracy.

At the beginning of the charging cycle, if the battery voltage is below 2.457V, the LTC1731 will precharge the battery with only 10% of the full-scale current to avoid stressing the depleted battery. Once the battery voltage reaches 2.457V, normal charging can commence. Charging is terminated by a user-programmed timer. After this timer has completed its cycle, the charging can be restarted by removing and then reapplying the input voltage source, or by shutting down the part momentarily. A built-in end-of-charge (C/10) comparator indicates that the charging current has dropped to 10% of the full-scale current. The output of this comparator can also be used to stop battery charging before the timer completes its cycle.

The LTC1731 is available in the 8-pin MSOP and SO packages.

OPERATION AND CIRCUIT DESCRIPTION

Figure 1 shows a detailed schematic of a 500mA single cell Li-Ion battery charger using the LTC1731-4.2. The charge current is programmed by the combination of a program resistor (R_{PROG}), from the PROG pin to ground

and a sense resistor (R_{SENSE}), between the V_{CC} and SENSE pins. R_{PROG} sets a program current through an internal, trimmed 800Ω resistor, setting up a voltage drop from V_{CC} to the input of the current amplifier (CA). The current amplifier controls the gate of an external P-channel MOSFET (Q1) to force an equal voltage drop across R_{SENSE} , which in turn, sets the charge current. When the potential at the BAT pin approaches the preset float voltage, the voltage amplifier starts sinking current, which decreases the required voltage drop across R_{SENSE} , thereby reducing the charge current.

Charging begins when the potential at the V_{CC} pin rises above 4.1V. At the beginning of the charge cycle, if the battery voltage is below 2.457V, the charger goes into trickle charge mode. The trickle charge current is 10% of the full-scale current. If the battery voltage stays low for one quarter of the total programmed charge time, the charge sequence is terminated.

The charger goes into the fast charge, constant-current mode after the voltage on the BAT pin rises above 2.457V. In constant-current mode, the charge current is set by the combination of R_{SENSE} and R_{PROG} . When the battery approaches the final float voltage, the voltage loop takes control and the charge current begins

LT, LTC, LTM, Linear Technology and the Linear logo are registered trademarks of Linear Technology Corporation. All other trademarks are the property of their respective owners.

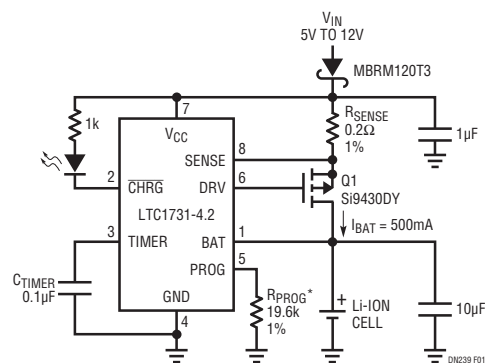

to decrease. When the current drops to 10% of the full-scale charge current, an internal comparator turns off the pull-down N-channel MOSFET at the $\overline{\text{CHRG}}$ pin and connects a weak current source to ground to indicate an end-of-charge (C/10) condition.

An external capacitor on the TIMER pin (C_{TIMER}) sets the total charging time. Once the timer cycle completes, the charging is terminated immediately and the $\overline{\text{CHRG}}$ pin is forced to a high impedance state. To restart the charge cycle, simply remove the input supply and then reapply it, or alternatively, float the PROG pin momentarily.

For batteries such as lithium-ion that require accurate final float potential, the internal 2.457V reference, voltage amplifier and the resistor divider provide regulation with better than $\pm 1\%$ accuracy. For NiMH and NiCd batteries, the LTC1731 can be turned into a current source by simply connecting the TIMER pin to V_{CC} . When in the constant-current only mode, the voltage amplifier, timer and the trickle charge function are all disabled.

When the input voltage is not present, the charger goes into a sleep mode, dropping I_{CC} to $7\mu\text{A}$. This greatly reduces the current drain on the battery and increases the standby time. The charger can always be shut down by floating the PROG pin. An internal current source will pull this pin's voltage high and clamp it at 3.5V.

PROGRAMMING CHARGE CURRENT

The formula for the battery charge current is:

$$I_{\text{BAT}} = (I_{\text{PROG}}) \cdot (800\Omega/R_{\text{SENSE}})$$

$$= (2.457V/R_{\text{PROG}}) \cdot (800\Omega/R_{\text{SENSE}})$$

where R_{PROG} is the total resistance from the PROG pin to ground.

For example, if a 500mA charge current is needed, select a value for R_{SENSE} that will drop 100mV at the maximum charge current. $R_{\text{SENSE}} = 0.1V/0.5A = 0.2\Omega$, then calculate:

$$R_{\text{PROG}} = (2.457V/500\text{mA}) \cdot (800\Omega/0.2\Omega) = 19.656\text{k}$$

For best accuracy over temperature and time, 1% resistors are recommended. The closest 1% resistor value is 19.6k.

TYPICAL APPLICATION

1.5A Single Cell Battery Charger

The LTC1731 can also be connected as a switcher-based battery charger for higher charging current applications (see Figure 2). As in the linear charger, the charge current is set by R3 and R5. The $\overline{\text{CHRG}}$ pin output will indicate an end-of-charge (C/10) condition when the average current drops down to 10% of the full-scale value. A $100\mu\text{F}$ bypass capacitor is required at the BAT pin to keep the ripple voltage low.

CONCLUSION

The LTC1731 makes a very compact, low parts count and low cost multiple battery chemistry charger. The onboard programmable timer provides charge termination without interfacing to a microprocessor.

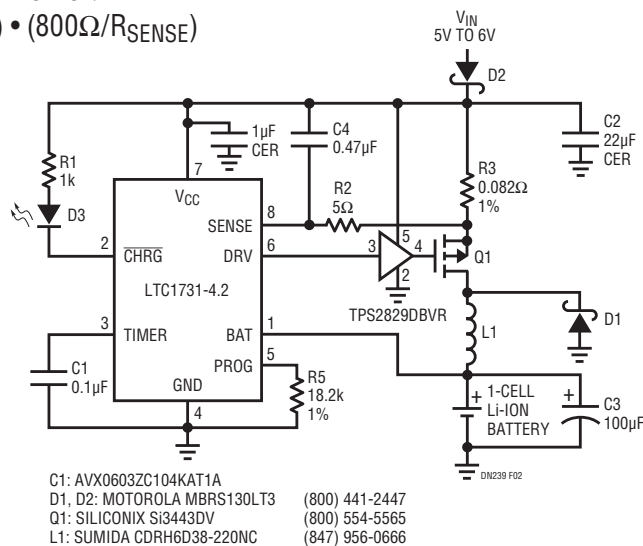

Figure 2. Single Cell 1.5A Li-Ion Battery Charger

Data Sheet Download

www.linear.com

For applications help,
call (408) 432-1900

Linear Technology Corporation

dn239f_conv LT/TP 0900 340K • PRINTED IN THE USA

