



US006770498B2

(12) **United States Patent**
Hsu

(10) **Patent No.:** **US 6,770,498 B2**
(45) **Date of Patent:** **Aug. 3, 2004**

(54) **LED PACKAGE AND THE PROCESS MAKING THE SAME**

(75) Inventor: **Cheng-Hsiang Hsu**, Taichung (TW)

(73) Assignees: **Lingsen Precision Industries, Ltd.**, Taichung (TW); **Cotco Holdings Ltd.**, Kwai Chung (HK)

(*) Notice: Subject to any disclaimer, the term of this patent is extended or adjusted under 35 U.S.C. 154(b) by 56 days.

(21) Appl. No.: **10/263,805**

(22) Filed: **Oct. 4, 2002**

(65) **Prior Publication Data**

US 2004/0000727 A1 Jan. 1, 2004

(30) **Foreign Application Priority Data**

Jun. 26, 2002 (TW) 91113988 A

(51) **Int. Cl.⁷** **H01L 21/66**

(52) **U.S. Cl.** **438/26; 438/29**

(58) **Field of Search** 438/26, 27, 28, 438/29, 34; 257/98, 99, 100, 79, 81, 787

(56) **References Cited**

U.S. PATENT DOCUMENTS

5,698,866 A * 12/1997 Doiron et al. 257/99
6,670,648 B2 * 12/2003 Isokawa et al. 257/99
6,707,069 B2 * 3/2004 Song et al. 257/79

* cited by examiner

Primary Examiner—Sara Crane

(74) *Attorney, Agent, or Firm*—Browdy and Neimark

(57) **ABSTRACT**

The present invention is to provide a process for fabricating light emitting diode (LED) packages. The process begins with a first step of providing a platelike frame having a plurality of cells, each of which is composed of a main plate and a separate arm. Secondly, an LED die and a reflecting ring are respectively mounted on a top surface of each main plate such that the die is located at a center of the reflecting ring. Next, connect a conductive wire between a top surface of the die and a top surface of the separate arm by wire bonding technique. And then, mold a domed transparent encapsulant on each of the cells. The encapsulant encapsulates the die, the reflecting ring and the conductive wire and covers the main plate and the separate arm, and fills a space between the main plate and the separate arm to remain their spaced apart. Finally, cut the frame according to the size of each cell, and then LED packages are obtained.

5 Claims, 8 Drawing Sheets

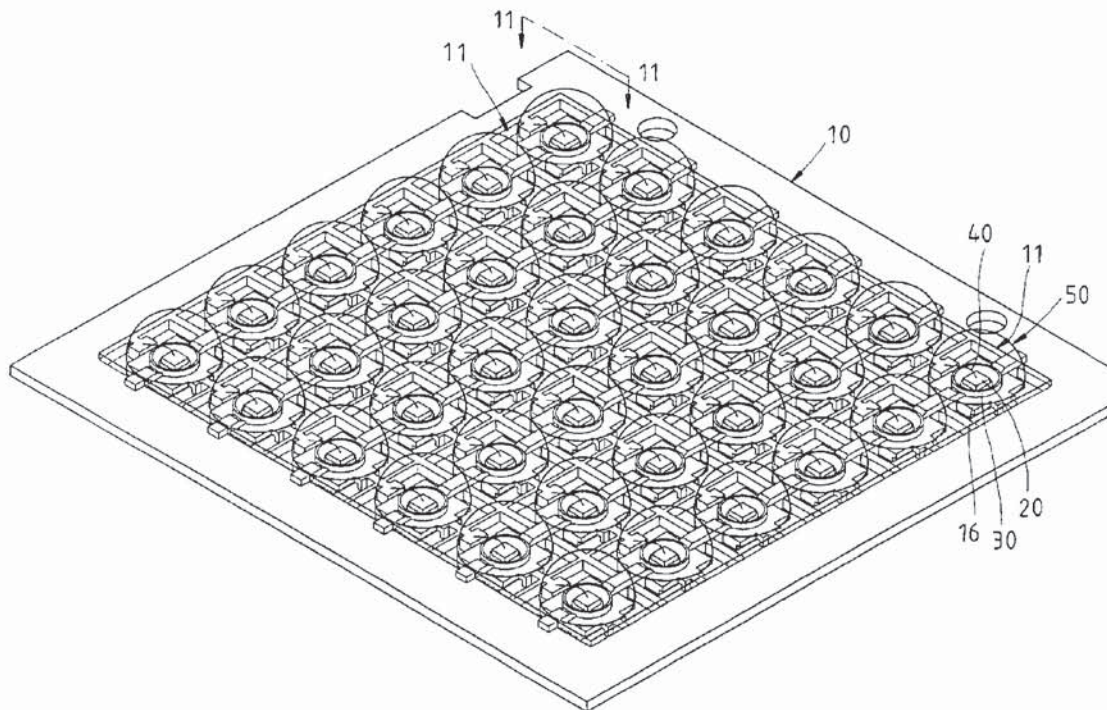

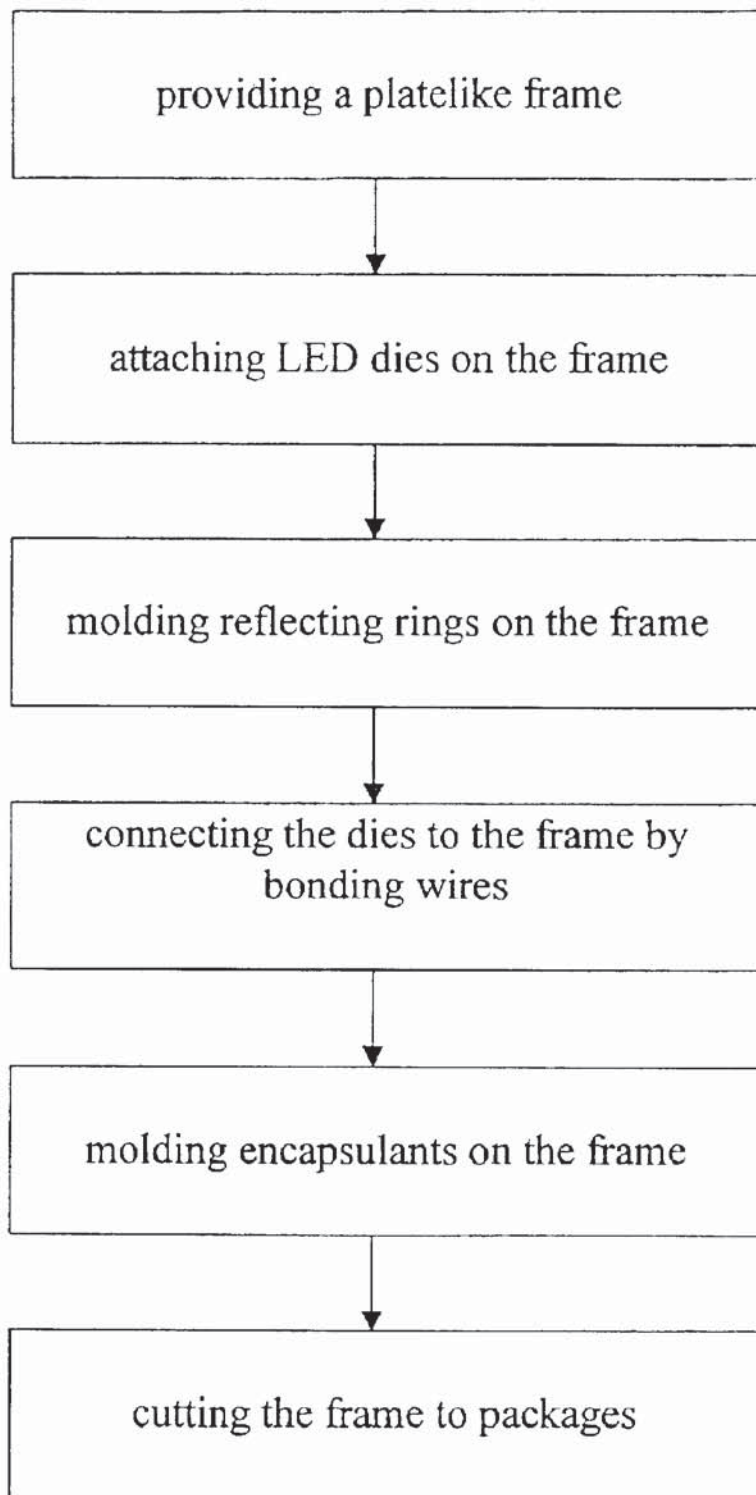

FIG. 1

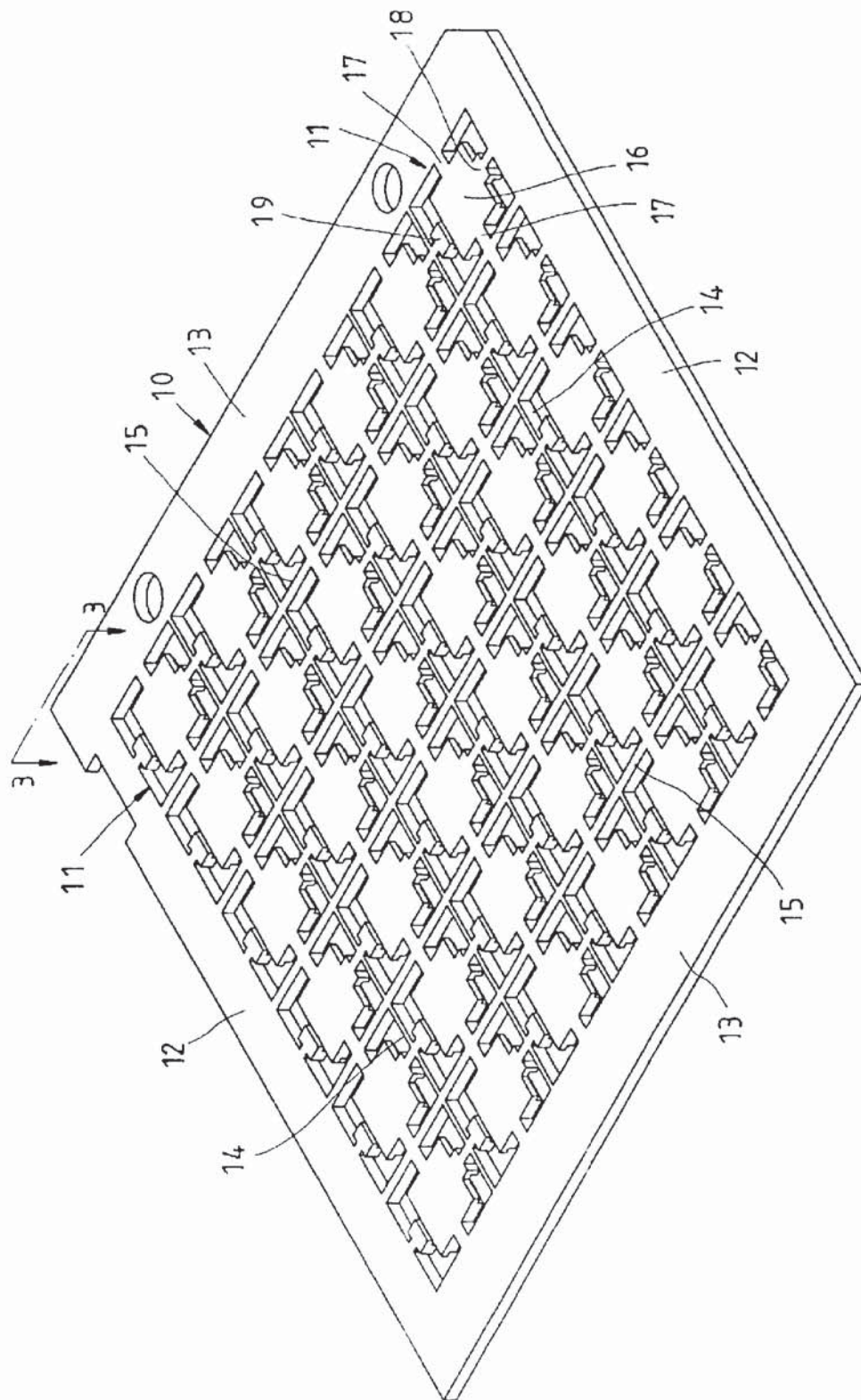

FIG. 2

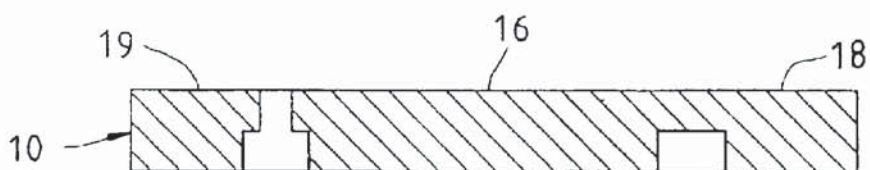

FIG. 3

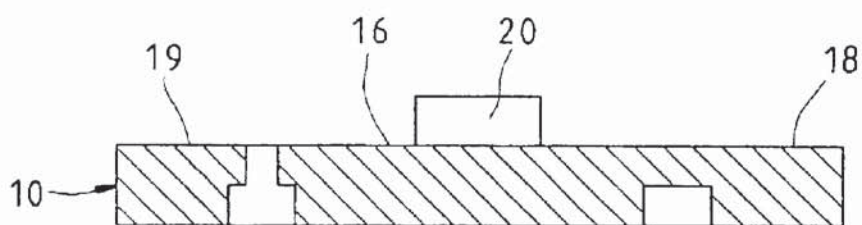

FIG. 5

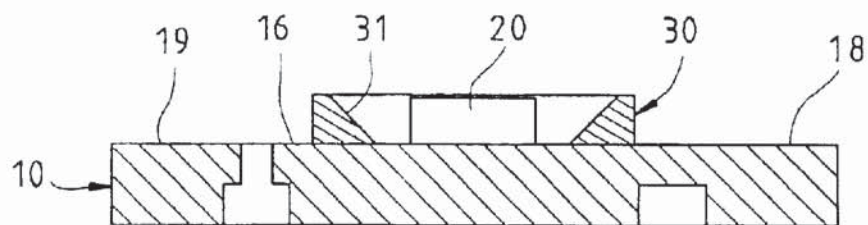

FIG. 7

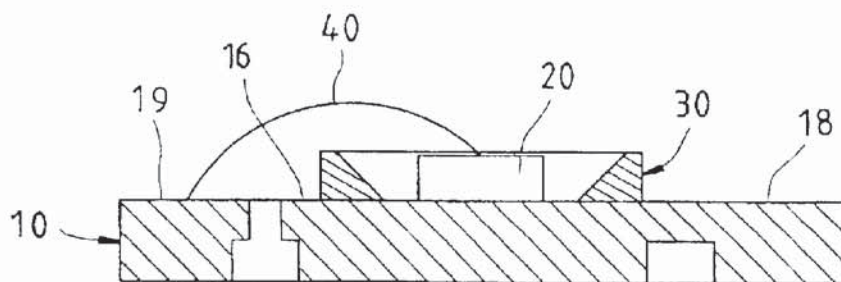

FIG. 9

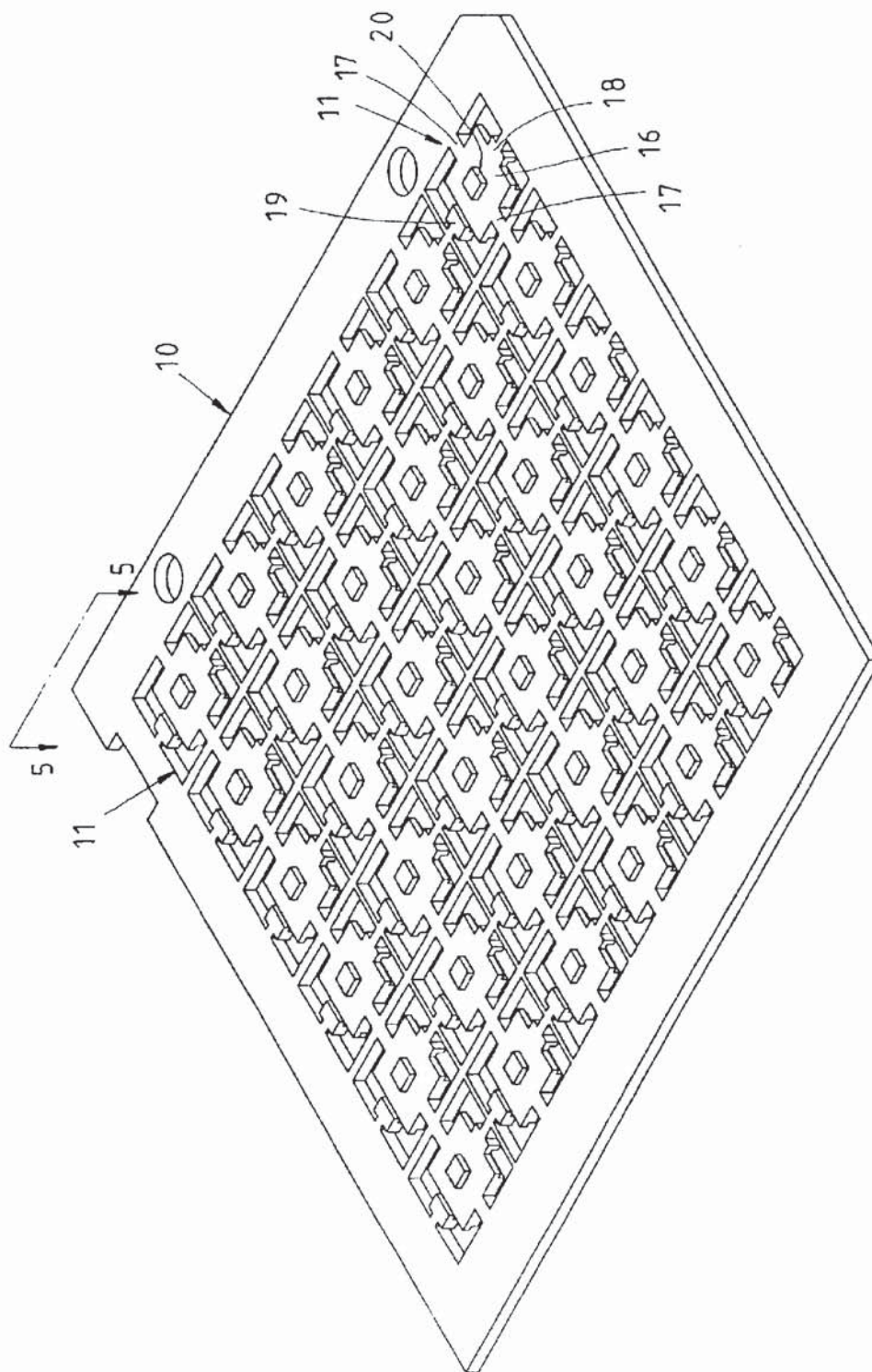

FIG. 4

Explore Litigation Insights

Docket Alarm provides insights to develop a more informed litigation strategy and the peace of mind of knowing you're on top of things.

Real-Time Litigation Alerts



Keep your litigation team up-to-date with **real-time alerts** and advanced team management tools built for the enterprise, all while greatly reducing PACER spend.

Our comprehensive service means we can handle Federal, State, and Administrative courts across the country.

Advanced Docket Research



With over 230 million records, Docket Alarm's cloud-native docket research platform finds what other services can't. Coverage includes Federal, State, plus PTAB, TTAB, ITC and NLRB decisions, all in one place.

Identify arguments that have been successful in the past with full text, pinpoint searching. Link to case law cited within any court document via Fastcase.

Analytics At Your Fingertips



Learn what happened the last time a particular judge, opposing counsel or company faced cases similar to yours.

Advanced out-of-the-box PTAB and TTAB analytics are always at your fingertips.

API

Docket Alarm offers a powerful API (application programming interface) to developers that want to integrate case filings into their apps.

LAW FIRMS

Build custom dashboards for your attorneys and clients with live data direct from the court.

Automate many repetitive legal tasks like conflict checks, document management, and marketing.

FINANCIAL INSTITUTIONS

Litigation and bankruptcy checks for companies and debtors.

E-DISCOVERY AND LEGAL VENDORS

Sync your system to PACER to automate legal marketing.