

(19) Japanese Patent Office (JP)

(12) Official Gazette for Kokai Patent Applications (A)

(11) Japanese Patent Application Kokai Publication No.

Kokai No.: Hei6(1994)-319177

(43) Kokai Publication Date: November 15, 1994

(51) Int.Cl. ⁵	Identification Symbol	JPO File Number	FI	Tech.Indic
H04Q 9/00	311 B	7170-5K		
	301 E	7170-5K		
	D	7170-5K		

Request for Examination: Not Submitted
Number of Claims: 1 OL
(Total of 17 pages in the original Japanese)

(21) Application Number: Hei6(1994)-26816

(22) Filing Date: February 24, 1994

(31) Priority Application Number: 021917

(32) Priority Date: February 24, 1993

(33) Priority Country: United States of America (US)

(71) Applicant: 590000400

Hewlett-Packard Company
3000 Hanover Street Palo Alto, CA,
U.S.A

(72) Inventor: Robert C. Leichiner

131 Dunsmuir Way, Menlo Park, California 94025,
U.S.A.

(74) Representative: Attorney Hajime Furuya (and two others)

(54) [Title of the Invention]

Adaptive remote control system

(57) [Abstract]

[Constitution]

Radio remote control system (100) comprises an adaptive intelligent controller similar to a hand-held remote controller for interacting with a responding controlled device (150, 250, 300). The controlled device, which is positioned close to the controller, is polled by the controller with regards to availability as well as with regards to which variables of the controlled device are available for control by the remote control system. The controlled device responds to the controller, in response to the above. Then, the controller provides appropriate user interface (122), based on information received from the controlled device. The user interface on the controller comprises, for example, an interactive LCD display screen (112) on a hand-held control unit, displays the control icon of the controlled device, and displays the state of the controlled device. Between the controller and the controlled device, infrared-ray (IR) communication links (106 and 110) are provided.

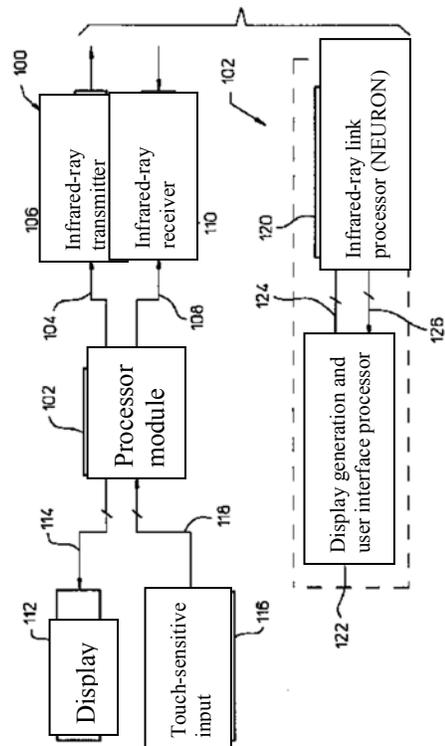

(2)

[Claim]

1. A wireless system for remotely controlling controlled devices thereof, comprising a controller,

wherein the controller is equipped with a means for conducting polling to the controlled devices, regarding the accessibility of the device to be controlled by the controller, as well as regarding which variables of the device can be utilized for control, display, and other processing by the controller, and

the controlled device is equipped with a means for responding to the controller and notifying the controller that the controller can access to the controlled device, as well as which variables of the device can be utilized for control, display, and other processing by the controller.

[Detailed Explanation of the Invention]

[0001]

[Industrial Field of Application] The present invention relates to a wireless remote controller, and more particularly, to an adaptive intelligent remote controller.

[0002] [Prior Art] The traditional wireless remote controllers are divided into several types. One type of traditional wireless remote controller is a dedicated-use type, which is equipped with a built-in or pre-programmed command information for a particular device which is to be remotely controlled by the remote controller. For example, in the dedicated-use remote controller, which is sold with the television receiver of a particular type, an appropriate combination of internal commands and control functions for the TV receiver of this particular type have been inputted therein by the manufacturer of the television receiver. These commands are stored in the read-only memory (ROM) of the remote controller, for example.

[0003] General preprogrammed multifunction remote controllers may have internal commands and control functions which are defined for a set of a large number of controlled devices such as a television, video cassette recorder, cable converter device, and the like. A general preprogrammed multifunction controller determines a specific subset to which a specific controlled device belongs. Each particular subset of the control device has a set of specific commands. This determination is made, for example, by a user performing a series of button operations for the remote controller. This series of button operations designates which set of commands should be utilized to connect the controlled device and the remote controller.

[0004] Another type of traditional wireless remote controller detects and reads a set of control codes from a remote controller which is originally sold with a controlled device, and thereby learns a set of control codes for various members of the controlled device group. Such devices are disclosed in U.S. Patent No. 4,905,279 by Nishio.

[0005] In the traditional remote controller of such types, the control codes are energized by pressing the buttons labeled such as "Power" or "Channel" on the remote controller. In the existing-type wireless remote controller which is capable of learning a set of commands from the remote controller sold with the controlled device, the learning function can be started by pressing the "learning" button provided on the remote controller, for example.

[0006] In many cases, the user of the remote controller changes his/her location by moving from a first area in the house to a second area in the house, for example. In the first area, the user may start operating various entertainment devices or equipment, or set various environment variables, such as temperature and lighting, to appropriate levels thereof. However, when the user moves to other areas in the house, there are other devices and equipment to be controlled, and also there are other environment variables to be set.

[0007] U.S. Patent No. 5,109,222 granted to Welty discloses a remote control system which is capable of controlling a variety of devices electrically operated in various areas of a house by utilizing a handheld control unit. The handheld control unit communicates with the system utilizing an infrared sensor installed in each room of the house. In order to receive the remote signals sent from the infrared sensor in each room and process the received remote signals, a central computer is required. The central computer emits control signals to the respective various devices which are electrically operated in the respective rooms. The controlled device is capable of sending back the signals to the remote controller held by the user via the computer, in order to provide feedback to the user regarding the devices. The remote controller unit has a plurality of control switches, also visually displays information transmitted from the device, and has a display screen to allow the user to know the status of the various devices. The computer presents and displays a menu form to the remote controller so that the user is allowed to make a selection from various options presented in the menu. In Welty's system, the central computer needs to be able to access to all of the locations by utilizing the infrared-ray sensor located in each room. The central computer directly controls the respective devices from the central location where it is located.

[0008]

[Problem that the Invention is to Solve]

An independent and stand-alone wireless controller which does not require a pre-programmed central computer, and which is capable of conducting control on its own in real time even when any device is in the immediate vicinity of the controller has been in demand. Such an adaptive universal controller is equipped only with preprogrammed control routines, and thus it can avoid some of the drawbacks of the traditional controllers, which have had to utilize a fixated central computer to control various devices in a house.

[0009]

(3)

[Means for Solving the Problem] The present invention is to provide a stand-alone adaptive universal remote controller. This controller adapts in real time by itself; even when there is any device or apparatus with compatibility in the immediate vicinity of the remote controller, the controller is capable of controlling such compatible device or apparatus. The remote controller can be considered to possess a large number of properties as needed. In other words, the controller adapts itself and constitutes itself to control a number of devices located in the vicinity thereof, which are possibly very different from each other, at the same time.

[0010] What is provided is an adaptive standalone remote control system which conducts polling to each of the controlled devices located in the immediate vicinity, and determines which device is available and what properties the available device has. The remote control system of the present invention provides to the user a single hand-held remote controller which constitutes a suitable user interface relative to each of the available devices or apparatuses located in the vicinity thereof. In this case, the user interface is utilized, for example, in a manner so that the user can control the available controlled devices in the immediate vicinity, according to some sort of command or setting inputted by the user by utilizing the user interface presented on the user interface screen of the controlled device. Communications of information between the remote controller and the controlled device are performed, for example, via a two-way infrared-ray link.

[0011] An important aspect of the present invention is that the controlled device is polled by the controller. If the controlled device is available, the controlled device responds to polling, indicating to the controller that the controlled device is available. The controller also informs the controller of which device variable is available for controlling, and of the state of the variable as an option. Availability and status information may be displayed on the user interface of the controller. The controller configures an appropriate user interface in real time and presents it to the user. In this case, the interface is constituted by utilizing the information received from the controlled device. The information provided from the controlled device includes information to help controller construct useful control interface. The apparatus controller can manage several devices at the same time.

[0012] The wireless system of the present invention comprises the controller, which is a hand-held wireless infrared-ray remote control unit in one working example of the present invention. The remote control unit is equipped with a circuit to conduct polling to the controlled device, regarding the availability of the device to be managed by the controller, as well as regarding which variables of the devices can be utilized for management by the controller. The controlled device is equipped with a means by which it responds to the controller, and by which it informs the controller that the device can be utilized for the management, and that certain variables of the device can be utilized in the same manner. The controller is also equipped with a means for constituting an appropriate interface to the controlled device on the basis of the information received from the device. The controller is further equipped with a means for displaying the status of the device, which is exemplified as an interactive LCD screen and the like. The controller is also

equipped with a means for the user's inputting commands, which is exemplified as a touch-sensitive interactive LCD display and the like. The controller is equipped with a means for communicating with the controlled device, which is exemplified as an infrared-ray (IR) link and the like. By utilizing the remote control unit, it becomes possible to conduct polling to a number of the controlled devices at the same time for the management thereof.

[0013] The method for remotely controlling the controlled devices by the controller comprises
 a step for conducting polling to at least one controlled device by utilizing the controller,
 a step for notifying the controller that a certain device is accessible,
 a step for notifying the controller which variable is available for control, and
 a step for configuring an appropriate control interface based on the information received from the controlled device.
 It is the controlled device that executes the information regarding the accessibility and availability, and provides such information.

[0014] The method for remotely controlling the controlled devices comprises a step for conducting polling to the devices regarding the accessibility to be managed by the controller, as well as which variables are available for management. Each of the control devices communicates with the controller to inform the controller that the device is available, and that the variables are controlled. The controller device configures an appropriate interface for that device based on information received from the device. The method comprises a step for displaying the status of the controlled device on the interface of the controller.

[0015] The step for informing the controller through communication by the controlled devices with the controller that the device is available, as well as which variables of the device are to be controlled, comprises conducting communications by means of an infrared-ray communication device, a wired communication device, or other wireless communication devices.

[0016]

[Working Examples] The accompanying drawings, which are incorporated as part of this specification, illustrate the working examples of the present invention; and, in conjunction with the detailed explanation of the present invention, they serve to explain the principles of the present invention.

[0017] Figure 1 shows one working example of the controller of the adaptive wireless control system. The controller is a hand-held control unit, or controller 10 as shown in the figure. Hand-held controller 10 is equipped with thin rectangular housing 12; the front panel thereof has POLL button 16, which serves to turn on the control unit to initiate the polling function. The polling function is generated when a variety of the controlled devices in the control unit area are queried by the control unit regarding the availability of the controlled device to be controlled by controller 10, as well as regarding which specific variables of the controlled device are to be controlled by hand-held controller 10. Controller 10 has a

(4)

property for quietly turning off after a predetermined inactivity period.

[0018] Hand-held controller 10 is equipped with window 18 for transmitting and receiving infrared (IR) signals as part of the IR link between controller 10 and the controlled devices located in the immediate vicinity of the controller. IR link has a specific range and bandwidth requirements, is equipped with an appropriate protocol for managing conflicts between the signals from two or more control devices or the controller, and thus provides a means for communicating between the controller and all of the devices located in the immediate vicinity thereof.

[0019] The transmission medium for the controller unit is not limited to the IR link. For example, other communication media and technologies utilizing twisted pair or radio transmission may also be utilized. These various transmission media and technologies require various amounts of auxiliary circuits. The IR links are well suited for the system of the present invention. Although alternative communications media may also be utilized, IR has an advantage of limiting the communications to the devices located in the vicinity thereof, which is an advantage in many possible application scenarios.

[0020] What is provided in hand-held controller 10 is a means for conducting polling to the controlled devices, regarding the availability of the device, as well as regarding which variables of the device are available for control by the controller. The controlled device comprises a means for responding to the polling by the controller, and notifying to the controller that the device is accessible. The controlled device is also equipped with a means for communicating information regarding which variables are available for control.

[0021] Interactive screen 20, exemplified as a touch-sensitive liquid crystal display (LCD) screen, provides a means for displaying the availability and current status of the controlled device. Controller 10 is also equipped with a means for constituting an appropriate display and control interface on interactive screen 20 based on the information received from the controlled device.

[0022] In operation, controller 10 generates polling messages to all of the controlled devices in the immediate vicinity thereof. The polling message is generated periodically upon request of the user, or in response to an external signal received from the controller environment. The controlled device available in the vicinity of the controller is capable of recognizing the polling message, and is capable of responding with the information regarding the identification thereof. In response to a further request message from the controller, or by itself, the controlled device supplies additional information to the controller.

[0023] The mechanism for communicating with the controller additional information regarding the variables is provided in the respective controlled devices. For example, the mechanism is capable of communicating with the controller the type and range of values for the controlled variables. When a controlled device in a predetermined format, such as a video cassette recorder, lamp, TV,

thermostat, and the like, is recognized, the standard icon corresponding to the device is generated on the screen of the controller. Alternatively, the controlled device may be capable of providing an appropriate icon.

[0024] The messages and standard icons may be communicated by means of commercially available components utilized in the controlled device, which are discussed in more detail below. Commercially-available Neuron communication and control processor integrated circuit which are manufactured as a Motorola MC143150 or MC143120 licensed from Eschelon Corporation are equipped with a certain standard network variable type (SNVT) structure. These Eschelon SNVT have a value of a predetermined range. The range can be communicated to the controller. For example, range of variables for temperature (SNVT_temp) is from -274 □ to +6279 □. Variables for %, which is a continuous level (SNVT_lev_cont), is from 0 to 100%. Variables for a discrete level (SNVT_lev_disc) have a range of (Off/Low/Medium/High/On). Variables for the ASCII character string (SNVT_Str_asc) are 30 characters as a maximum length.

[0025] From the controlled device, other messages or various graphics/text messages can be sent to the controller. Such messages as the above includes, for example, a variety of text strings and menus.

[0026] In order to assist the controller user in handling the specific controlled devices, the controller can be equipped with help messages. For example, the controlled device, such as a copying machine, incorporates a "help" message such as "Press here for instructions regarding creating a duplex copy."

[0027] For the controller user, a command such as "The tension of the feeder of this copier has to be adjusted to 'x' grams" can be provided.

[0028] The menu-driving controlled device provides various menus to the controller. The user can make selections from the menu.

[0029] It is also possible to receive personal communication from another controller, and display such on the controller. For example, while the audio-visual presentation is being made by a user in the conference, the user can use the controller to control the slide projector and indoor lighting. Other users, such as the chairperson of the conference, may send a message such as "remaining time is 5 minutes."

[0030] As an example of the basic operation of the wireless remote control system of the present invention, suppose that there is a user who owns a very specific television receiver. This television receiver is equipped with a switchable auxiliary receptacle, for example, for supplying power to a popcorn making machine connected to an auxiliary receptacle. Thus, this television receiver may have a "popcorn making" function.

(5)

[0031] It should be noted that a general multifunction household-use remote controller for a television receiver is not equipped with any special button or special user interface display which can be utilized with an appropriate label for "popcorn making" function. The user of a general television remote controller is expected to learn that "second audio program" key labelled as "SAP," which is utilized on a general remote controller, actually means "popcorn making," for example.

[0032] However, in the controller system of the present invention, with regards to this particular function, the user interface display can be configured in real time by utilizing a screen icon appropriately labelled on the interface screen. Thus, when conducting polling to a television receiver relative to both the common functions and the uncommon functions, the controller of the present invention is capable of adapting itself to the information obtained by the controller.

[0033] Figure 2 shows interactive LCD display screen 20 of Figure 1, where several typical screen icons are shown. These icons appear on LCD display screen 20, for example, when the user enters the room and presses the POLL button on hand-held controller 10. These icons include desk lamp 22, floor lamp 24, television receiver 26, and video cassette recorder 28. These icons represent the results of polling conducted to the devices located in the immediate vicinity of the controller. Edit soft key 30 displayed on LCD display screen 20 may be utilized to provide an editing function for text displayed on the screen, for example, by providing a soft keyboard and the like for editing or inserting text as needed.

[0034] Figure 3 shows the user interface LCD screen for displaying the control panel to control various operations of a controlled device, desk lamp. The items on the screen are displayed, for example, when the user initially enters the room and conducts polling to the available devices located in the room.

[0035] Figure 4 shows a functional block diagram of a general control module. General control module 50 may be utilized to arbitrarily realize either the controller or the controlled device. One example of the controller is a hand-held control unit of a wireless control system. An example of the controlled device is a video cassette recorder which is equipped with a built-in communication and control interface device. As described below, the control module can be realized, by partially utilizing commercially available Neuron communication and control processor integrated circuit which are manufactured as a Motorola MC143150 or MC143120 based on the licensing by Eschelon Corporation.

[0036] The controller is equipped with processor 52; and processor 52 is equipped with an output terminal for transmitting output signals to an input terminal of infrared-ray (IR) interface circuit module 54 via signal line 56. The output terminal of IR interface circuit

module 54 is connected through signal line 58 to the input terminal of IR transmitter module 60. IR transmitter module 60 receives electrical signals from IR interface circuit module 54, and transmits the infrared-ray signals, which have been appropriately encoded, to the IR receiver of the controlled device. IR receiver module 62 receives the infrared-ray signal, which have been appropriately encoded, from the controlled device, and transmits electrical signals via signal line 64 to the input terminal of IR interface circuit module 54. The output terminal of IR interface circuit module 54 is connected via signal line 66 to the input terminal of processor 52.

[0037] The communication and control processor module with the functions of processor 52 and IR interface circuit 54 incorporated can be realized, by partially utilizing commercially available Neuron communication and control processor integrated circuit which are manufactured as a Motorola MC143150 or MC143120 based on the licensing by Eschelon Corporation.

[0038] As for the uses as the controller, the I/O terminal of processor 52 is connected via bus 68 to arbitrary user interface device 70, such as the interactive LCD display as shown in Figure 1, for example. Alternatively, user interface device 70 may comprise PDA, computer, personal computer, palmtop computer, or other similar devices, each of which is equipped with the capability of the adaptive remote control system, operates as a controller, and is appropriately programmed.

[0039] As for the uses as the controlled device, the I/O terminal of processor 52 is connected via another bus or signal line 72 to arbitrary user controllable device 74, such as a lighting device, video cassette recorder, and the like. Alternatively, user interface device 70 may comprise PDA, personal computer, palmtop computer, or other similar devices, each of which operates as a controller or a controlled device interfacing with intelligent devices such as instruments, entertainment devices, industrial hardware, and the like equipped with the capability of the adaptive remote control system, and each of which is equipped with the capability of the adaptive remote control system, operates as a controller, and is appropriately programmed.

[0040] The ability of the adaptive remote control system to be utilized for a particular controlled device can be extended by causing the adaptive remote control system to store the information for the particular controlled device into the memory thereof. This information is understood as known information by the controller, based on past history such as home-use stereo system, custom add-on to control a printer, plug-in memory chip, and the like.

[0041] Special add-on programming is performed by utilizing a plug-in card or ROM device which are utilized for PDA, personal computer, palmtop computer, and other devices

Explore Litigation Insights

Docket Alarm provides insights to develop a more informed litigation strategy and the peace of mind of knowing you're on top of things.

Real-Time Litigation Alerts



Keep your litigation team up-to-date with **real-time alerts** and advanced team management tools built for the enterprise, all while greatly reducing PACER spend.

Our comprehensive service means we can handle Federal, State, and Administrative courts across the country.

Advanced Docket Research



With over 230 million records, Docket Alarm's cloud-native docket research platform finds what other services can't. Coverage includes Federal, State, plus PTAB, TTAB, ITC and NLRB decisions, all in one place.

Identify arguments that have been successful in the past with full text, pinpoint searching. Link to case law cited within any court document via Fastcase.

Analytics At Your Fingertips



Learn what happened the last time a particular judge, opposing counsel or company faced cases similar to yours.

Advanced out-of-the-box PTAB and TTAB analytics are always at your fingertips.

API

Docket Alarm offers a powerful API (application programming interface) to developers that want to integrate case filings into their apps.

LAW FIRMS

Build custom dashboards for your attorneys and clients with live data direct from the court.

Automate many repetitive legal tasks like conflict checks, document management, and marketing.

FINANCIAL INSTITUTIONS

Litigation and bankruptcy checks for companies and debtors.

E-DISCOVERY AND LEGAL VENDORS

Sync your system to PACER to automate legal marketing.