



US007698097B2

(12) **United States Patent**  
**Pasolini et al.**

(10) **Patent No.:** **US 7,698,097 B2**  
(45) **Date of Patent:** **Apr. 13, 2010**

(54) **METHOD FOR CONTROLLING A PEDOMETER BASED ON THE USE OF INERTIAL SENSORS AND PEDOMETER IMPLEMENTING THE METHOD**

6,898,550 B1 5/2005 Blackadar et al. .... 702/182  
7,169,084 B2\* 1/2007 Tsuji ..... 482/8  
7,297,088 B2\* 11/2007 Tsuji ..... 482/3  
2001/0031031 A1\* 10/2001 Ogawa et al. .... 377/24.2

(75) Inventors: **Fabio Pasolini**, S. Martino Siccomario (IT); **Ivo Binda**, Voghera (IT)

**FOREIGN PATENT DOCUMENTS**

(73) Assignee: **STMicroelectronics S.R.L.**, Agrate Brianza (IT)

GB 2 359 890 9/2001  
JP 63-262784 10/1988  
JP 04-192095 7/1992

(\* ) Notice: Subject to any disclaimer, the term of this patent is extended or adjusted under 35 U.S.C. 154(b) by 707 days.

**OTHER PUBLICATIONS**

(21) Appl. No.: **11/537,986**

Tasaka, Translation of JP 63262784, published Oct. 31, 1988.\*  
Tasaka, Translation of H04-192095, published Jul. 10, 1992.\*

(22) Filed: **Oct. 2, 2006**

(65) **Prior Publication Data**

US 2007/0143069 A1 Jun. 21, 2007

\* cited by examiner

(30) **Foreign Application Priority Data**

Oct. 3, 2005 (EP) ..... 05425684

(57) **ABSTRACT**

(51) **Int. Cl.**

**G01C 22/00** (2006.01)  
**G06F 17/40** (2006.01)

*Primary Examiner*—Hal D Wachsman  
(74) *Attorney, Agent, or Firm*—Lisa K. Jorgenson; Robert Iannucci; Seed IP Law Group PLLC

(52) **U.S. Cl.** ..... **702/160; 702/176; 702/178;**  
377/24.2

(58) **Field of Classification Search** ..... **702/160,**  
702/176, 178

See application file for complete search history.

(56) **References Cited**

**U.S. PATENT DOCUMENTS**

6,175,608 B1\* 1/2001 Pyles et al. .... 377/24.2

A method for controlling a pedometer includes the steps of: generating a signal correlated to movements of a user of the pedometer; and detecting steps of the user on the basis of the signal. The method moreover envisages the steps of checking whether sequences of detected steps satisfy pre-determined conditions of regularity; updating a total number of valid steps if the conditions of regularity are satisfied; and preventing the updating of the total number of valid steps if the conditions of regularity are not satisfied.

**26 Claims, 3 Drawing Sheets**

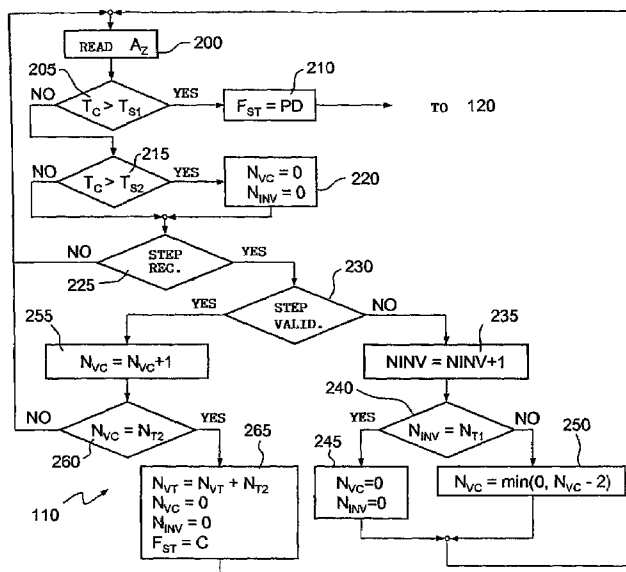

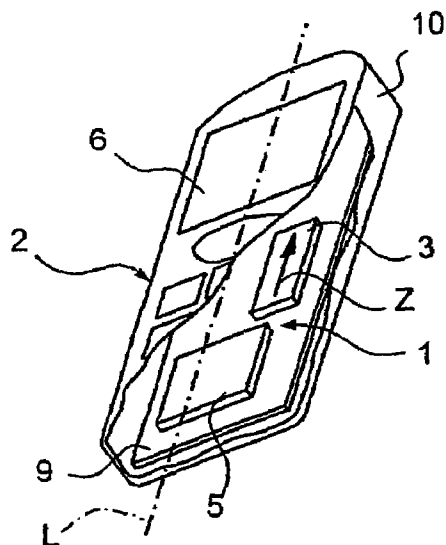

Fig. 1

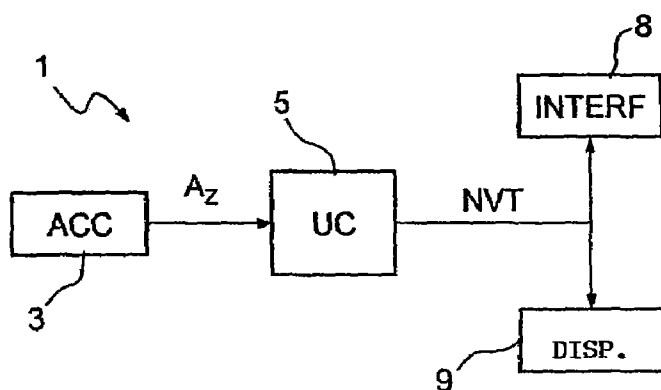

Fig. 2

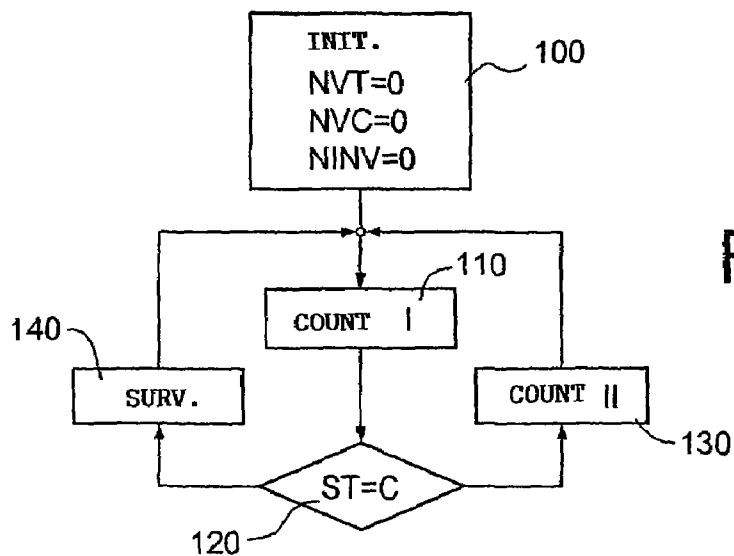
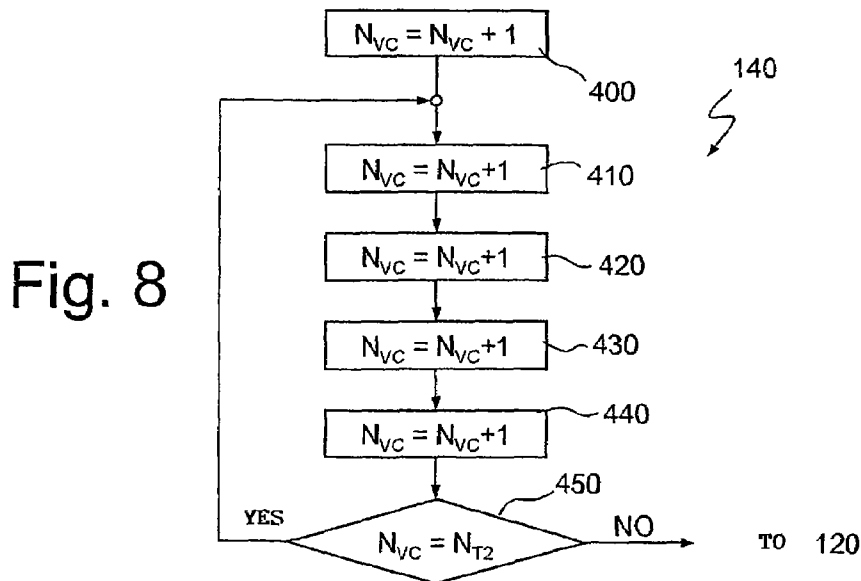
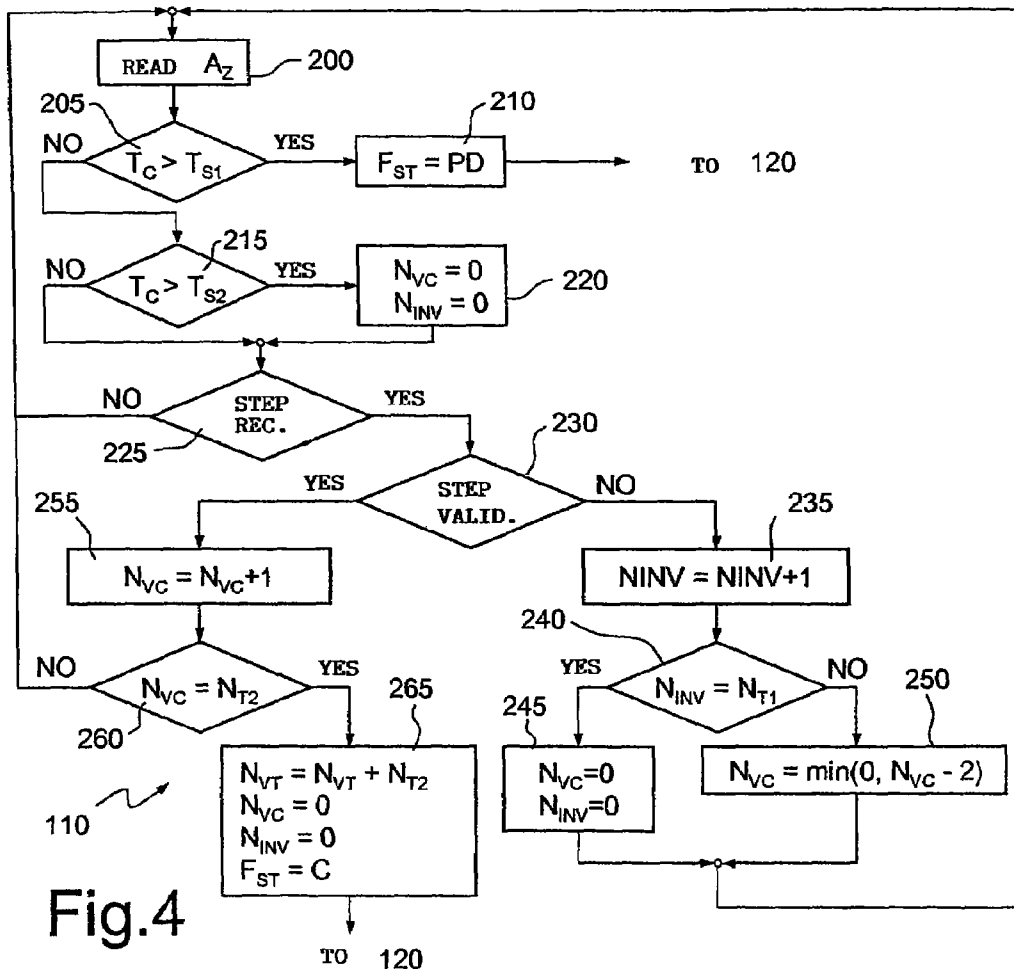

Fig. 3



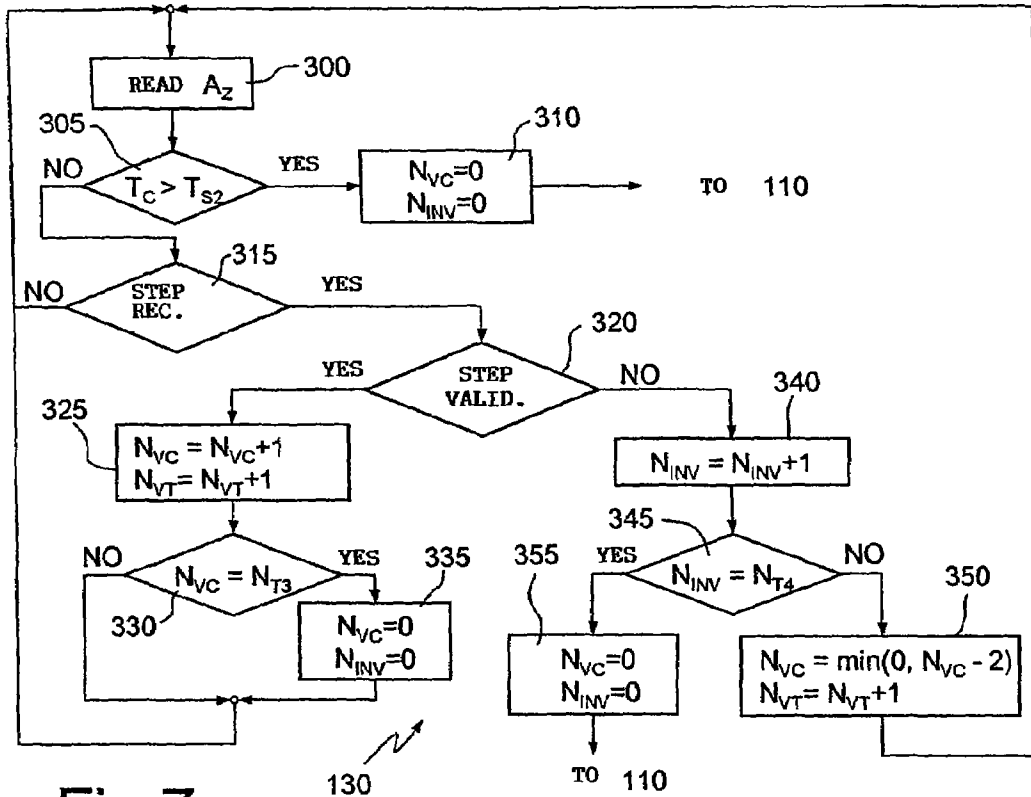

Fig.7

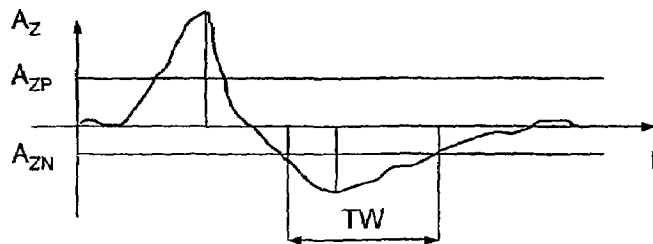

Fig.5

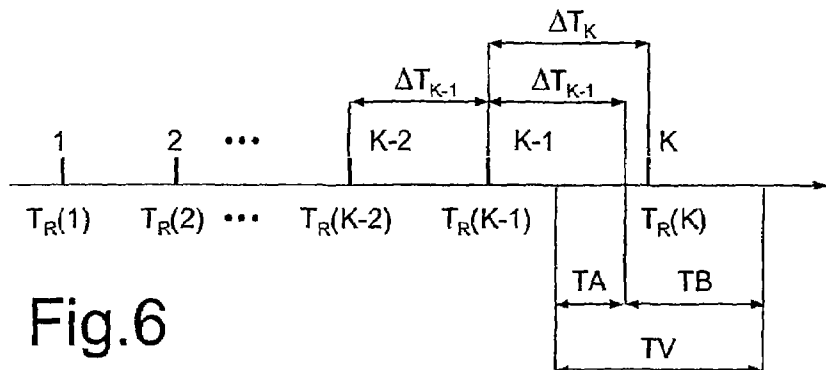

Fig.6

1

**METHOD FOR CONTROLLING A  
PEDOMETER BASED ON THE USE OF  
INERTIAL SENSORS AND PEDOMETER  
IMPLEMENTING THE METHOD**

BACKGROUND OF THE INVENTION

1. Field of the Invention

The present invention relates to controlling a pedometer based on the use of inertial sensors.

2. Description of the Related Art

As is known, a pedometer is a device that can be carried by a user and has the function of counting the number of steps during various walking or running activities for estimating accordingly the distance traveled. The indications supplied are useful for quantifying the motor activity performed by a person in the course of a given period, for instance, for clinical purposes, for assessing the athletic performance, or even just for simple personal interest.

The reliability of a pedometer obviously depends on the precision in estimating the step length of the user at the various rates of locomotion, but also on the selectivity in recognizing and ignoring events not correlated to the gait, which, however, cause perturbations resembling those produced by a step. For example, many pedometers are based on the use of inertial sensors, which detect accelerations along a substantially vertical axis, and recognize that a step has been made by a user when the time plot of the acceleration signal shows given morphological characteristics. Basically, a step is recognized when the pedometer detects a positive acceleration peak (i.e., a peak directed upwards) having an amplitude greater than a first threshold, followed, at a distance of some tenths of second, by a negative acceleration peak (directed downwards) having an amplitude greater than a second threshold. However, there are many random events that can interfere with correct recognition of the step. Impact or other external vibrations and given movements of the user can, in fact, give rise to so-called "false positives", i.e., to events that are recognized as steps even though in actual fact they are not, because the morphological characteristics produced are compatible. Events of this type are very frequent also in periods of rest, when the user, albeit not walking, in any case performs movements that can be detected by the pedometer. In the majority of cases, also "isolated" steps or very brief sequences of steps are far from significant and should preferably be ignored because they are, in effect, irrelevant in regard to assessment of the motor activity for which the pedometer is being used.

Of course, in all these situations, the count of the steps may prove to be completely erroneous.

BRIEF SUMMARY OF THE INVENTION

One embodiment of the present invention is a method for controlling a pedometer and a pedometer which overcome the described above limitations.

One embodiment is a method for controlling a pedometer. The method includes: generating a signal correlated to movements of a user of the pedometer; detecting steps of the user based on the signal; checking whether sequences of the

2

regularity are satisfied; and preventing updating of the total number of valid steps if the conditions of regularity are not satisfied.

BRIEF DESCRIPTION OF THE SEVERAL  
VIEWS OF THE DRAWINGS

For a better understanding of the invention, an embodiment thereof is now described, purely by way of non-limiting example and with reference to the attached plate of drawings, wherein:

FIG. 1 shows a simplified and partially sectioned perspective view of a portable electronic device incorporating a pedometer according to the present invention;

FIG. 2 is a simplified block diagram of the pedometer of FIG. 1;

FIG. 3 shows a flowchart corresponding to a control method according to the present invention executed by the pedometer of FIGS. 1 and 2;

FIG. 4 is a more detailed flowchart corresponding to a first step of the method of FIG. 3;

FIG. 5 is a graph that represents first quantities used in the method according to the present invention;

FIG. 6 is a graph that represents second quantities used in the method according to the present invention;

FIG. 7 is a more detailed flowchart corresponding to a second step of the method of FIG. 3; and

FIG. 8 is a more detailed flowchart corresponding to a third step of the method of FIG. 3.

DETAILED DESCRIPTION OF THE INVENTION

With reference to FIGS. 1 and 2, a pedometer 1 is integrated within a portable electronic device, such as a cell phone 2. The pedometer 1 comprises an inertial sensor 3, a control unit 5, equipped with a nonvolatile-memory module (not illustrated herein), a display 6, and a communication interface 8, all housed on a card 9, which is, in turn, fixed within a casing 10 of the cell phone 2. In the embodiment described herein, the control unit 5 performs control functions of the pedometer 1 and, moreover, presides over bi-directional communication and over handling of the functions envisaged for the cell phone 2. Likewise, the display 6, which is obviously arranged so as to be visible from the outside of the casing 10, can be used for displaying both information regarding the pedometer 1 and, more in general, information regarding the operation of the cell phone 2.

The inertial sensor 3 is a linear accelerometer of a MEMS (micro-electromechanical systems) type and is mounted on the card 9 so as to have a detection axis Z substantially parallel to a longitudinal axis L of the casing 10 of the cell phone 2. In practice, the detection axis Z and the longitudinal axis L are substantially horizontal, when the cell phone 2 is resting on a surface, and substantially vertical or slightly inclined with respect to the vertical when the cell phone 2 is handled. The inertial sensor 3 supplies at output an acceleration signal  $A_z$ , which is correlated to the accelerations undergone by the inertial sensor 3 itself along the detection axis Z.

The control unit 5 receives and processes the acceleration signal  $A_z$  as explained in detail hereinafter for identifying and counting a total number of valid steps  $N_{VT}$  made by a user wearing or carrying the pedometer 1, for example, on his belt or on his shoulder. In addition, the control unit 5 is preferably configured for generating an estimate of the distance traveled

# Explore Litigation Insights

Docket Alarm provides insights to develop a more informed litigation strategy and the peace of mind of knowing you're on top of things.

## Real-Time Litigation Alerts



Keep your litigation team up-to-date with **real-time alerts** and advanced team management tools built for the enterprise, all while greatly reducing PACER spend.

Our comprehensive service means we can handle Federal, State, and Administrative courts across the country.

## Advanced Docket Research



With over 230 million records, Docket Alarm's cloud-native docket research platform finds what other services can't. Coverage includes Federal, State, plus PTAB, TTAB, ITC and NLRB decisions, all in one place.

Identify arguments that have been successful in the past with full text, pinpoint searching. Link to case law cited within any court document via Fastcase.

## Analytics At Your Fingertips



Learn what happened the last time a particular judge, opposing counsel or company faced cases similar to yours.

Advanced out-of-the-box PTAB and TTAB analytics are always at your fingertips.

## API

Docket Alarm offers a powerful API (application programming interface) to developers that want to integrate case filings into their apps.

## LAW FIRMS

Build custom dashboards for your attorneys and clients with live data direct from the court.

Automate many repetitive legal tasks like conflict checks, document management, and marketing.

## FINANCIAL INSTITUTIONS

Litigation and bankruptcy checks for companies and debtors.

## E-DISCOVERY AND LEGAL VENDORS

Sync your system to PACER to automate legal marketing.