

© TCP/IP
Murphy

TK
5105.585
.M87
1995

OVER
80,000 COPIES
IN PRINT!

TCP/IP

Fifth Edition

Tutorial and Technical Overview

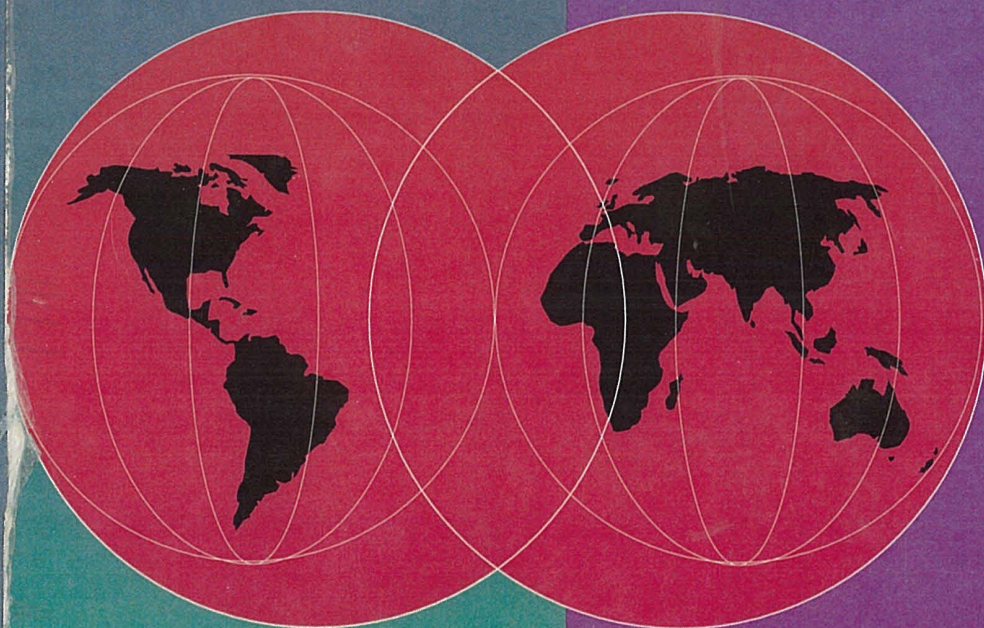

- Comprehensive Coverage of TCP/IP
- Real-World Implementations
- Internet Access and Navigation Tools

The IBM logo, consisting of the letters 'IBM' in a stylized, bold, sans-serif font with horizontal stripes.

EAMON MURPHY • STEVE HAYES • MATTHIAS ENDERS

TCP/IP

Fifth Edition

Tutorial and Technical Overview

TCP/IP Tutorial and Technical Overview begins with the basics of the TCP/IP architecture, explaining the IP, ICMP, ARP, RARP, UDP, TCP, and DNS protocols, then continues with descriptions of routing protocols such as Hello, RIP, OSPF, EGP, and BGP. It moves on to application protocols and connectivity. New to this Fifth Edition is an overview of Internet access methods and an introduction to selected Internet navigation tools.

This book is unique in its description of IBM's TCP/IP-based products in heterogeneous networks, and the book also provides information about how to connect other manufacturers' equipment to IBM systems.

Over 80,000 copies of this comprehensive guide to TCP/IP protocols have been distributed worldwide. It was first developed as a "redbook" at **IBM's International Technical Support Organization** for networking specialists to use in planning, writing, implementing, and porting applications for TCP/IP-based networks.

At the ITSO, new products and systems under development are given a workout by IBM engineers from around the world. The experience gained is documented in practical guides called "**redbooks**," which, because they are written largely by people with extensive practical experience, offer a much more direct and problem-solving approach than many books on similar topics.

John E. McNamara says,

"This is an easy-to-read introduction to the latest TCP/IP technology, told to you by practicing engineers in the field, with a level of detail sufficient to understand the exciting features of the technology without getting bogged down in too much detail. A useful stepping-stone to reading and understanding the actual standards. Delightful to read. Clearly written.

As an engineer myself, I particularly appreciated the clear explanations of various design problems and solution approaches, along with the discussions of the pros and cons of various techniques, and the reasoning as to why particular solutions are chosen." — Author of **Local Area Networks** and **Technical Aspects of Data Communications**

PRENTICE HALL
Upper Saddle River, NJ 07458



TCP/IP

Fifth Edition

Tutorial and Technical Overview

EAMON MURPHY ■ STEVE HAYES ■ MATTHIAS ENDERS

Contributors to earlier editions: Gerard Bourbigot ■ Frank Vanderwiele ■
Bob Boffs ■ Richard Ryniker ■ Bruce Wilder ■ Ricardo Haragutchi ■
Jim Curran ■ Paul D. Bosco ■ Frederic Debulois ■ Francis Li ■
Niels Christiansen ■ Philippe Beaupied ■ Lesia Antonowytch Cox ■
Peter Frick ■ Carla Sadler ■ Dave Shogren

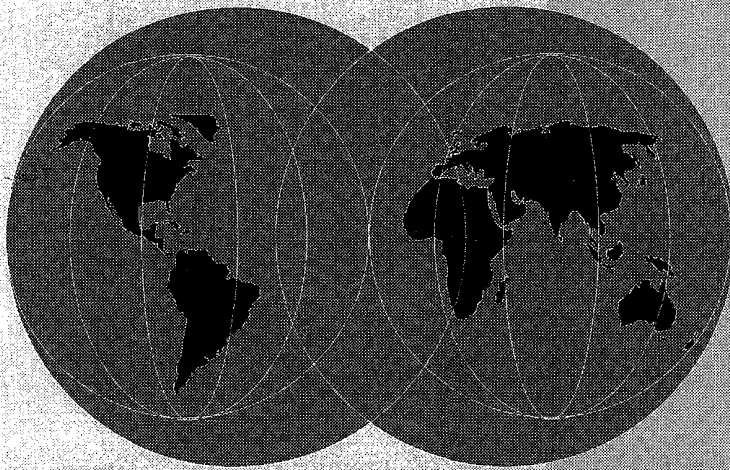

The IBM logo, consisting of the letters 'IBM' in a bold, sans-serif font, with horizontal stripes through the letters.



PRENTICE HALL PTR, UPPER SADDLE RIVER, NEW JERSEY 07458

TK 5105.585 .M87 1995

Murphy, Eamon, 1953-

TCP/IP tutorial and
technical overview

Fifth Edition

© Copyright International Business Machines Corporation 1989, 1995. All rights reserved.

Note to U.S. Government Users — Documentation related to restricted rights — Use, duplication or disclosure is subject to restrictions set forth in GSA ADP Schedule Contract with IBM Corp.

For information about redbooks:
<http://www.redbooks.ibm.com/redbooks>



Send comments to:
redbooks@vnet.ibm.com

Published by



Prentice Hall PTR
Prentice-Hall, Inc.
A Simon & Schuster Company
Upper Saddle River, NJ 07458

The publisher offers discounts on this book when ordered in bulk quantities. For more information, contact

Corporate Sales Department,
Prentice Hall PTR
One Lake Street
Upper Saddle River, NJ 07458
Phone: 800-382-3419; FAX: 201-236-714
E-mail (Internet): corpsales@prenhall.com

For book and bookstore information



<http://www.prenhall.com>

Printed in the United States of America

1 0 9 8 7 6 5 4 3 2 1

ISBN 0-13-460858-5

Prentice-Hall International (UK) Limited, *London*
Prentice-Hall of Australia Pty. Limited, *Sydney*
Prentice-Hall Canada Inc., *Toronto*
Prentice-Hall Hispanoamericana, S.A., *Mexico*
Prentice-Hall of India Private Limited, *New Delhi*
Prentice-Hall of Japan, Inc., *Tokyo*
Simon & Schuster Asia Pte. Ltd., *Singapore*
Editora Prentice-Hall do Brasil, Ltda., *Rio de Janeiro*

Contents

Figures	xi
Tables	xvii
Preface	xix
Special Notices	xix
Acknowledgments	xxii
Chapter 1. The Internet: Past, Present and Future	1-1
1.1 Introduction	1-1
1.2 Internetworks	1-2
1.2.1 The Internet	1-3
1.2.2 ARPANET	1-3
1.2.3 NSFNET	1-4
1.2.4 EBONE	1-6
1.2.5 CREN	1-6
1.2.6 Cypress	1-7
1.2.7 DRI	1-7
1.2.8 European Academic Research Network (EARN)	1-7
1.2.9 Réseaux Associés pour la Recherche Européenne (RARE)	1-7
1.2.10 Réseaux IP Européens (RIPE)	1-8
1.2.11 Japanese Internet	1-8
1.2.12 Commercial Use of the Internet	1-9
1.2.13 Information Super Highway	1-10
1.3 IBM and the Internet	1-10
1.3.1 The IBM Open Blueprint	1-10
1.3.2 AnyNet	1-15
1.3.3 IBM Global Network Services	1-18
1.3.4 Internet Connection Services	1-18
1.4 Future	1-20
1.4.1 Future - High-Speed Networking	1-21
1.5 Request For Comments (RFC)	1-22
1.5.1 Internet Standards	1-24
1.5.2 For Your Information (FYI)	1-25
1.5.3 Obtaining RFCs	1-25
1.5.4 Major Internet Protocols	1-26
Chapter 2. Architecture and Protocols	2-1
2.1 Architectural Model	2-1
2.1.1 Internetworking	2-1

121590604

2.12.2 TCP Concept	2-93
2.12.3 TCP Application Programming Interface	2-103
2.13 Asynchronous Transfer Mode (ATM)	2-104
2.13.1 Address Resolution (ATMARP and InATMARP)	2-104
2.13.2 Classical IP over ATM	2-107
2.13.3 ATM LAN Emulation	2-112
2.13.4 Classical IP over ATM versus LAN Emulation	2-116
2.14 TCP/IP and OSI	2-116
2.14.1 Differences	2-117
2.14.2 The Internet World and OSI	2-118
2.14.3 TCP/IP and OSI Coexistence Considerations	2-120
2.15 Data Link Switching: Switch-to-Switch Protocol	2-125
2.15.1 Introduction	2-125
2.15.2 Functional Description	2-125
2.16 IP: The Next Generation (IPng)	2-127
2.16.1 The Requirements for IPng	2-128
2.16.2 IPng Candidates	2-129
2.16.3 IP Version 6 (IPv6)	2-130
2.17 Summary	2-148
Chapter 3. Routing Protocols	3-1
3.1 Basic IP Routing	3-1
3.1.1 Routing Daemons	3-4
3.2 Historical Perspective	3-4
3.2.1 The ARPANET Routing Architecture	3-4
3.2.2 NSFNET Routing Architecture	3-8
3.3 Interior Routing Protocols	3-8
3.3.1 Routing Algorithms	3-9
3.3.2 The Hello Protocol	3-14
3.3.3 Routing Information Protocol (RIP)	3-17
3.3.4 Open Shortest Path First Protocol (OSPF) Version 2	3-25
3.4 Exterior Routing Protocols	3-49
3.4.1 Exterior Gateway Protocol (EGP)	3-49
3.4.2 Border Gateway Protocol (BGP)	3-52
3.4.3 IP Routing Protocols in IBM TCP/IP Products	3-69
Chapter 4. Application Protocols	4-1
4.1.1 Characteristics of Applications	4-1
4.1.2 Client/Server Model	4-1
4.2 TELNET	4-3
4.2.1 TELNET Operation	4-4
4.2.2 Implementations	4-10
4.3 Trivial File Transfer Protocol (TFTP)	4-21

2.1.2 Internet Architecture	2-3
2.2 Addressing	2-7
2.2.1 The IP Address	2-8
2.2.2 Subnets	2-10
2.2.3 Special IP Addresses	2-16
2.2.4 Unicasting, Broadcasting and Multicasting	2-17
2.2.5 The IP Address Exhaustion Problem	2-21
2.2.6 Private Internets	2-26
2.2.7 Classless Inter-Domain Routing (CIDR)	2-26
2.2.8 Domain Name System	2-31
2.3 Internet Protocol (IP)	2-36
2.3.1 IP Datagram	2-36
2.3.2 IP Routing	2-48
2.4 Internet Control Message Protocol (ICMP)	2-52
2.4.1 ICMP Messages	2-53
2.4.2 ICMP Applications	2-62
2.4.3 ICMP for IP Version 6	2-62
2.5 Ping	2-63
2.6 Traceroute	2-65
2.7 Internet Group Management Protocol (IGMP)	2-66
2.7.1 IGMP Messages	2-66
2.7.2 IGMP Operation	2-67
2.8 Address Resolution Protocol (ARP)	2-69
2.8.1 Ethernet versus IEEE 802.3	2-69
2.8.2 ARP Overview	2-72
2.8.3 ARP Detailed Concept	2-73
2.8.4 ARP and Subnets	2-77
2.8.5 Proxy-ARP or Transparent Subnetting	2-77
2.9 Reverse Address Resolution Protocol (RARP)	2-79
2.9.1 RARP Overview	2-79
2.9.2 RARP Concept	2-79
2.10 Ports and Sockets	2-81
2.10.1 Ports	2-81
2.10.2 Sockets	2-81
2.10.3 Basic Socket Calls	2-82
2.10.4 An Example Scenario	2-84
2.10.5 Implementations	2-86
2.11 User Datagram Protocol (UDP)	2-88
2.11.1 Ports	2-89
2.11.2 UDP Datagram Format	2-90
2.11.3 UDP Application Programming Interface	2-91
2.12 Transmission Control Protocol (TCP)	2-92
2.12.1 Sockets	2-92

4.10 Remote Procedure Call (RPC)	4-129
4.10.1 RPC Concept	4-130
4.10.2 Implementations	4-134
4.11 Network Computing System (NCS)	4-136
4.11.2 Implementations	4-141
4.12 Network File System (NFS)	4-144
4.12.1 Concept	4-144
4.12.2 Implementations	4-149
4.13 Kerberos Authentication and Authorization System	4-155
4.13.1 Assumptions	4-156
4.13.2 Naming	4-156
4.13.3 Kerberos Authentication Process	4-157
4.13.4 Kerberos Database Management	4-161
4.13.5 Kerberos Authorization Model	4-162
4.13.6 Kerberos Version 5 Enhancements	4-162
4.13.7 Implementations	4-163
4.14 Network Management	4-166
4.14.1 Standards	4-167
4.14.2 Structure and Identification of Management Information (SMI)	4-168
4.14.3 Management Information Base (MIB)	4-169
4.14.4 Simple Network Management Protocol (SNMP)	4-174
4.14.5 Common Management Information Protocol over TCP/IP (CMOT)	4-177
4.14.6 SNMP Distributed Programming Interface (SNMP DPI)	4-179
4.14.7 Simple Network Management Protocol Version 2 (SNMPv2)	4-181
4.14.8 MIB for SNMPv2	4-185
4.14.9 Party MIB	4-185
4.14.10 Single Authentication and Privacy Protocol	4-186
4.14.11 The New Administrative Model	4-187
4.14.12 Implementations	4-189
4.15 NetBIOS Services Protocol	4-197
4.15.1 Implementations	4-198
4.16 Line Printer Daemon	4-205
4.16.1 Implementations	4-205
4.17 BOOTstrap Protocol — BOOTP	4-210
4.17.1 Implementations	4-213
4.18 Dynamic Host Configuration Protocol (DHCP)	4-214
4.19 NETSTAT	4-220
4.20 Finger Protocol	4-220
4.21 Whois Protocol	4-221
4.22 Time and Daytime Protocols	4-221
4.23 Other Application Protocols	4-222
4.23.1 Network Database (NDB)	4-222
4.23.2 Network Information Systems (NIS)	4-223

4.3.1 Usage	4-21
4.3.2 Protocol Description	4-22
4.3.3 Implementations	4-24
4.4 File Transfer Protocol (FTP)	4-25
4.4.1 Overview of FTP	4-25
4.4.2 FTP Operations	4-26
4.4.3 Reply Codes	4-28
4.4.4 FTP Scenario	4-29
4.4.5 A Sample FTP Session	4-31
4.4.6 Implementations	4-31
4.5 Domain Name System (DNS)	4-39
4.5.1 The Distributed Name Space	4-39
4.5.2 Domain Resolution	4-40
4.5.3 Domain System Resource Records	4-44
4.5.4 Domain Name System Messages	4-45
4.5.5 A Simple Scenario	4-50
4.5.6 Extended Scenario	4-52
4.5.7 Transport	4-53
4.5.8 References	4-53
4.5.9 DNS Applications	4-54
4.5.10 Implementations	4-54
4.6 Simple Mail Transfer Protocol (SMTP)	4-64
4.6.1 How SMTP Works	4-66
4.6.2 SMTP and the Domain Name System	4-72
4.6.3 Post Office Protocol Mail Servers	4-73
4.6.4 References	4-75
4.6.5 Implementations	4-75
4.6.6 SMTP Gateways	4-86
4.6.7 SMTP and X.400	4-88
4.7 Multipurpose Internet Mail Extensions (MIME)	4-90
4.7.1 How MIME works	4-94
4.7.2 The Content-Type Field	4-95
4.7.3 The Content-Transfer-Encoding Field	4-101
4.7.4 Using Non-ASCII Characters in Message Headers	4-106
4.7.5 References	4-108
4.7.6 Implementations	4-108
4.8 Remote Execution Command Protocol (REXEC)	4-111
4.8.1 Principle of Operation	4-112
4.8.2 Implementations	4-112
4.9 X Window System	4-118
4.9.1 Functional Concept	4-119
4.9.2 Protocol	4-123
4.9.3 Implementations	4-124

4.23.3 CICS Socket Interface	4-224
4.23.4 IMS Socket Interface	4-225
4.23.5 Sockets Extended	4-225
4.23.6 REXX Sockets	4-226
4.23.7 RFC 1006	4-226
4.24 Summaries	4-226
4.24.1 Client/Server Relationships	4-226
4.24.2 APIs by Operating System	4-228
4.25 APIs by Protocol	4-228
Chapter 5. Connections	5-1
5.1 IBM 3172 Interconnect Controller	5-1
5.1.1 3172 TCP/IP Offload	5-2
5.2 HYPERchannel Adapter	5-5
5.2.1 Addressing Particularities	5-5
5.3 The IBM High-Performance Parallel Interface (HIPPI)	5-6
5.3.1 Implementations	5-7
5.3.2 HIPPI Draft Standards and Internet-Draft	5-8
5.3.3 Relationship of IBM HIPPI and the ANSI Draft Standards	5-8
5.4 CTC (Channel To Channel)	5-9
5.5 Continuously Executing Transfer Interface (CETI)	5-9
5.5.1 Implementations	5-10
5.6 SNALINK	5-11
5.6.1 Example	5-11
5.7 Fiber Distributed Data Interface (FDDI)	5-12
5.8 Serial Line IP (SLIP)	5-14
5.8.1 Implementations	5-14
5.8.2 Example	5-15
5.9 Point-to-Point Protocol (PPP)	5-15
5.10 TCP/IP and X.25	5-17
5.10.1 Implementations	5-17
5.11 3745 and Ethernet Adapter	5-20
5.11.1 Principle of Operation	5-20
5.11.2 Example	5-21
5.12 3174 Establishment Controller	5-22
5.13 PC and PS/2 Connections	5-23
5.13.1 Connections Supported by TCP/IP for OS/2	5-23
5.13.2 Connections Supported by TCP/IP for DOS	5-23
5.14 AIX/ESA Connections	5-25
5.15 RISC System/6000 Connections	5-25
5.15.1 RISC System/6000 Parallel Channel Attachment	5-26
5.15.2 RISC System/6000 ESCON Control Unit Adapter	5-26
5.16 The IBM Nways Router Family	5-26

5.16.1 IBM 6611 Network Processor	5-27
5.16.2 IBM 2210 Nways Multiprotocol Router	5-28
5.17 IBM 8229 Local Area Network Bridge	5-31
5.18 IBM 8271 EtherStreamer Switch	5-35
5.19 The IBM Hubs Family	5-36
5.19.1 IBM 8230 Token-Ring Controlled Access Unit	5-37
5.19.2 IBM 8222 Workgroup Hub	5-38
5.19.3 IBM 8224 Ethernet Stackable Hub	5-38
5.19.4 IBM 8244 FDDI Workgroup Concentrator	5-38
5.19.5 IBM 8250 Multiprotocol Intelligent Hub	5-39
5.19.6 IBM 8260 Multiprotocol Intelligent Hub	5-40
5.20 Connectivity Summary	5-42
Chapter 6. Internet Access	6-1
6.1 Gopher	6-2
6.1.1 Implementations	6-5
6.1.2 Veronica	6-5
6.2 World Wide Web	6-6
6.2.1 Implementations	6-10
6.3 Firewalls	6-10
6.3.1 IBM NetSP Secured Network Gateway	6-11
Appendix A. Bibliography	A-1
A.1 International Technical Support Center Publications	A-1
A.2 VM Publications	A-2
A.3 MVS Publications	A-2
A.4 DOS Publications	A-2
A.5 OS/2 Publications	A-3
A.6 AIX for RISC/6000 Publications	A-3
A.7 AIX/ESA	A-3
A.8 AIX General	A-4
A.9 AS/400 Publications	A-4
A.10 CETI Publications	A-4
A.11 HIPPI Publications	A-4
A.12 X.25 NPSI Publications	A-4
A.13 3172 Interconnect Controller Publications	A-5
A.14 6611 Network Processor Publications	A-5
A.15 8229 LAN Bridge Publications	A-5
A.16 Other IBM Systems Publications	A-5
A.17 DDN Network Information Center Publications	A-5
A.18 OSF Publications	A-6
A.19 ANSI Publications	A-6
A.20 Other Publications	A-6

Appendix B. Distributed Computing Environment (DCE)	B-1
B.1 History	B-1
B.2 Overview of DCE Technology Components	B-1
B.3 Implementations	B-2
B.3.1 MVS	B-3
B.3.2 VM	B-3
B.3.3 OS/400	B-3
B.3.4 AIX/6000	B-4
B.3.5 OS/2 and Windows	B-4
Glossary	X-1
Index	X-13

Figures

1-1.	IBM Networking Blueprint	1-12
1-2.	Common Transport Semantics	1-14
1-3.	APPC over TCP/IP	1-16
1-4.	Multiple Gateways	1-17
2-1.	Internet Examples	2-2
2-2.	Architectural Model	2-3
2-3.	Detailed Architectural Model	2-4
2-4.	Internet Router	2-7
2-5.	Assigned Classes of Internet Addresses	2-9
2-6.	A Subnet Configuration	2-13
2-7.	IP Routing without Subnets	2-14
2-8.	IP Routing with Subnets	2-15
2-9.	IP Address Space Usage	2-23
2-10.	Hierarchical Namespace	2-32
2-11.	The Generic Top-level Domains	2-33
2-12.	Domain Name Resolution	2-34
2-13.	Internet Protocol (IP)	2-36
2-14.	Base IP Datagram	2-37
2-15.	IP Datagram Format	2-38
2-16.	Loose Source Routing Option	2-45
2-17.	Strict Source Routing Option	2-46
2-18.	Record Route Option	2-46
2-19.	Internet Timestamp Option	2-47
2-20.	Direct and Indirect IP Routes	2-49
2-21.	Example IP Routing Table	2-50
2-22.	IP Routing Algorithm	2-51
2-23.	Internet Control Message Protocol (ICMP)	2-52
2-24.	ICMP Message Format	2-53
2-25.	ICMP Destination Unreachable	2-55
2-26.	ICMP Fragmentation Required with Link MTU	2-56
2-27.	ICMP Source Quench	2-56
2-28.	ICMP Redirect	2-57
2-29.	ICMP Echo and Echo Reply	2-57
2-30.	ICMP Router Advertisement	2-58
2-31.	ICMP Router Solicitation	2-58
2-32.	ICMP Time Exceeded	2-59
2-33.	ICMP Parameter Problem	2-60
2-34.	ICMP Timestamp Request and Timestamp Reply	2-60
2-35.	ICMP Information Request and Information Reply	2-61
2-36.	ICMP Address Mask Request and Reply	2-61

2-37.	Packet InterNet Groper (PING)	2-63
2-38.	Traceroute	2-65
2-39.	ICMP Message Format	2-66
2-40.	Address Resolution Protocol (ARP)	2-69
2-41.	Frame Formats for Ethernet and IEEE 802.3	2-70
2-42.	IEEE 802.2 LSAP Header	2-70
2-43.	IEEE 802.2 SNAP Header	2-71
2-44.	ARP Request/Reply Packet	2-74
2-45.	ARP Packet Reception	2-76
2-46.	Hosts Interconnected by a Router	2-77
2-47.	Proxy-ARP Router	2-78
2-48.	Reverse Address Resolution Protocol (RARP)	2-79
2-49.	Socket System Calls for Connection-Oriented Protocol	2-85
2-50.	Socket System Calls and Association	2-86
2-51.	User Datagram Protocol (UDP)	2-88
2-52.	UDP, A Demultiplexer Based on Ports	2-89
2-53.	UDP Datagram Format	2-90
2-54.	Pseudo-IP Header	2-91
2-55.	Transmission Control Protocol (TCP)	2-92
2-56.	TCP Connection	2-93
2-57.	The Window Principle	2-95
2-58.	Message Packets	2-95
2-59.	Window Principle	2-96
2-60.	Message Packets	2-96
2-61.	Window Principle Applied to TCP	2-97
2-62.	TCP Segment Format	2-98
2-63.	Pseudo-IP Header	2-99
2-64.	IP Datagram Option	2-100
2-65.	Maximum Segment Size Option	2-100
2-66.	Acknowledgment and Retransmission Process	2-101
2-67.	TCP Connection Establishment	2-102
2-68.	AAL5 CPCS-PDU Format	2-110
2-69.	CPCS-PDU Payload Format for IP PDUs	2-111
2-70.	Ethernet and Token-ring LAN Emulation	2-113
2-71.	TCP/IP and OSI	2-117
2-72.	Dual Stacks	2-120
2-73.	Application-Layer Gateway Node	2-121
2-74.	Transport-Layer Gateway Node	2-122
2-75.	Transport-Service Bridge Node	2-123
2-76.	Network Tunnels	2-124
2-77.	DLSw Compared to Bridging	2-126
2-78.	IPv6 Header	2-132
2-79.	IPv6 Type-Length-Value Option Format	2-135

2-80.	IPv6 Loose Source Routing Header	2-137
2-81.	IPv6 Fragment Header	2-138
2-82.	IPv6 Fragment Header	2-138
2-83.	IPv6 Flow Label	2-140
2-84.	TCP/IP Layered Model	2-148
3-1.	Router Operation of IP	3-2
3-2.	The ARPANET Backbone	3-5
3-3.	The Counting to Infinity Problem	3-11
3-4.	The Counting to Infinity Problem	3-12
3-5.	Hello Message Format	3-15
3-6.	RIP Message	3-18
3-7.	The Counting to Infinity Problem	3-21
3-8.	RIP-2 Message	3-23
3-9.	OSPF Packet Header	3-33
3-10.	OSPF Hello Packet	3-34
3-11.	OSPF Database Description Packet	3-37
3-12.	OSPF Link State Advertisement Header	3-38
3-13.	OSPF Router Links Advertisement	3-40
3-14.	OSPF Network Links Advertisement	3-42
3-15.	OSPF Summary Links Advertisement	3-43
3-16.	OSPF External Links Advertisement	3-44
3-17.	EGP Routing Update Message	3-51
3-18.	BGP-3 Header	3-58
3-19.	BGP-3 OPEN Message	3-59
3-20.	BGP-3 UPDATE Message	3-60
3-21.	BGP-3 NOTIFICATION Message	3-63
3-22.	BGP UPDATE Message	3-66
4-1.	The Client/Server Model of Applications	4-2
4-2.	TELNET	4-3
4-3.	Remote Login using TELNET	4-4
4-4.	The Symmetric TELNET Model	4-5
4-5.	Echo Option	4-6
4-6.	Internal TELNET Command Structure	4-9
4-7.	TELNET Server and Client	4-19
4-8.	3270 Full-Screen Server and Client	4-19
4-9.	TELNET Scénario	4-20
4-10.	Trivial File Transfer Protocol (TFTP)	4-21
4-11.	TFTP Packets	4-23
4-12.	File Transfer Protocol (FTP)	4-25
4-13.	FTP Principle	4-26
4-14.	FTP Scénario	4-30
4-15.	A Sample FTP Session	4-31
4-16.	The Domain Name System	4-39

4-17.	Using a Full Resolver for Domain Name Resolution	4-41
4-18.	Using a Stub Resolver for Domain Name Resolution	4-42
4-19.	DNS Message Format	4-46
4-20.	DNS Question Format	4-48
4-21.	DNS Answer Record Entry Format	4-49
4-22.	A Simple Configuration	4-50
4-23.	Zone Data for the Name Server	4-51
4-24.	Extended Configuration	4-52
4-25.	Sample NSMAIN DATA File for VM	4-57
4-26.	Sample NSMAIN DATA File for MVS	4-60
4-27.	DB2 Storage Group, Tablespace, and Table Definition	4-61
4-28.	Simple Mail Transfer Protocol (SMTP)	4-64
4-29.	Model for SMTP	4-68
4-30.	Normal SMTP Data Flow	4-70
4-31.	SMTP-RSCS/NJE Mail Gateway	4-86
4-32.	Multipurpose Internet Mail Extensions (MIME)	4-90
4-33.	A Complex Multipart Example	4-97
4-34.	Base64 Encoding	4-104
4-35.	The Base64 Alphabet	4-105
4-36.	A Sample UltiMail Session	4-110
4-37.	Remote Execution Command Protocol (REXEC)	4-111
4-38.	REXECD Principle	4-112
4-39.	REXECD Scheme under VM	4-114
4-40.	X Window System	4-118
4-41.	Concept of X Window System	4-120
4-42.	X Window System Window Structure	4-123
4-43.	MVS X Window System Application to Server	4-126
4-44.	Remote Procedure Call (RPC)	4-129
4-45.	RPC	4-130
4-46.	Portmap	4-133
4-47.	Network Computing System (NCS)	4-136
4-48.	NCS (Components of the Network Computing System)	4-137
4-49.	NIDL Compiler	4-139
4-50.	Network File System (NFS)	4-144
4-51.	NFS Mount Command	4-146
4-52.	NFS File I/O	4-148
4-53.	Kerberos Authentication and Authorization System	4-155
4-54.	Kerberos Authentication Scheme	4-158
4-55.	Kerberos Database	4-163
4-56.	Kerberos Database Remote Administration	4-164
4-57.	Network Management	4-166
4-58.	Management Information Base II (MIB-II)	4-170
4-59.	Object Identifier	4-173

4-60.	SNMP	4-175
4-61.	SNMP Message Format	4-177
4-62.	CMOT	4-178
4-63.	Lightweight Presentation Protocol (LPP)	4-179
4-64.	SNMP DPI Overview	4-180
4-65.	SNMP Version 2 Message Format	4-188
4-66.	Overview of NetView SNMP Support	4-190
4-67.	TCP/IP and NetBIOS	4-199
4-68.	NetBIOS Kit of TCP/IP V2.0 for OS/2	4-200
4-69.	NPF Overview	4-207
4-70.	BOOTP Message Format	4-211
4-71.	DHCP Message Format	4-216
4-72.	Components in the Network Database (NDB) Protocol	4-223
4-73.	Client/Server Relationships	4-227
4-74.	APIs for TCP/IP	4-228
4-75.	TCP/IP Layered Model	4-229
5-1.	LAN Types Supported on the 3172 with Interconnect Control Program (ICP)	5-1
5-2.	LAN Types Supported on the 3172-3 with the Offload Feature	5-2
5-3.	IBM 3172-3 Interconnect Controller	5-4
5-4.	HYPERchannel Network	5-6
5-5.	IBM HIPPI and MVS TCP/IP	5-7
5-6.	Relationship of ANSI HIPPI Draft Standards	5-8
5-7.	CETI Connection	5-10
5-8.	Principle of SNAlink Function	5-12
5-9.	IP and ARP over FDDI	5-13
5-10.	SLIP Example	5-15
5-11.	X.25 Example Scenario	5-19
5-12.	3745 and Ethernet Adapter	5-21
5-13.	8229 Connection Diagram	5-32
5-14.	8229 TCP/IP Support	5-33
5-15.	8229 TCP/IP Support	5-34
5-16.	Connectivity Summary	5-42
6-1.	Gopher	6-2

Tables

1-1.	Availability of APIs for IBM Platforms	1-13
1-2.	AnyNet Availability	1-18
1-3.	The Current state and status and STD numbers of Important Internet protocols	1-27
2-1.	Subnet Values for Subnet Mask 255.255.255.240	2-13
2-2.	IP network number usage between 1990 and 1994	2-21
3-1.	Type of Service Values	3-41
3-2.	BGP-3 UPDATE Path Attribute Type Values	3-61
3-3.	BGP OSPF Attribute-Field Mapping	3-64
4-1.	TELNET Options	4-7
4-2.	FTP Reply Codes	4-28
5-1.	IBM 2210 Model and Connectivity Offerings	5-29

Preface

This document is for customers, networking specialists and consultants working on projects involving connectivity between IBM systems and equipment manufactured by other companies. It should be used to gain a basic understanding of the Transmission Control Protocol/Internet Protocol (TCP/IP) protocol suite and to gain an overview of the possible functionality of the IBM TCP/IP based products in heterogeneous networks.

The document is organized as follows:

- Chapter 1, "The Internet: Past, Present and Future"

This chapter provides a brief history of the Internet and predicts how it is likely to develop in the future.

- Chapter 2, "Architecture and Protocols"

This chapter gives the basics of the TCP/IP architecture and explains the protocols: IP, ICMP, ARP, RARP, UDP, TCP and DNS.

- Chapter 3, "Routing Protocols"

This chapter describes the functionality of the TCP/IP routing protocols and explains the protocols: Hello, RIP, OSPF, EGP and BGP.

- Chapter 4, "Application Protocols"

This chapter describes the functionality of the TCP/IP application protocols and their implementations in the IBM products.

- Chapter 5, "Connections"

This chapter describes the connectivity supported by IBM products.

- Chapter 6, "Internet Access"

This chapter provides an overview of Internet access methods and introduces a selection of Internet navigation tools.

Special Notices

This publication is intended to help customers, FSC communications specialists and systems engineers understand the TCP/IP protocol suite and the characteristics of its implementation in the IBM TCP/IP products. The information in this publication is not intended as the specification of any programming interfaces that are provided by TCP/IP for VM, MVS, OS/400, AIX/RT, AIX PS/2, AIX/6000, AIX/370, OS/2 and DOS. See the PUBLICATIONS section of the IBM Programming Announcement for TCP/IP for

VM, MVS, OS/400, AIX/RT, AIX PS/2, AIX/6000, AIX/370, OS/2 and DOS for more information about what publications are considered to be product documentation.

References in this publication to IBM products, programs or services do not imply that IBM intends to make these available in all countries in which IBM operates. Any reference to an IBM product, program, or service is not intended to state or imply that only IBM's product, program, or service may be used. Any functionally equivalent program that does not infringe any of IBM's intellectual property rights may be used instead of the IBM product, program or service.

Information in this book was developed in conjunction with use of the equipment specified, and is limited in application to those specific hardware and software products and levels.

IBM may have patents or pending patent applications covering subject matter in this document. The furnishing of this document does not give you any license to these patents. You can send license inquiries, in writing, to the IBM Director of Commercial Relations, IBM Corporation, Purchase, NY 10577.

The information contained in this document has not been submitted to any formal IBM test and is distributed AS IS. The information about non-IBM (VENDOR) products in this manual has been supplied by the vendor and IBM assumes no responsibility for its accuracy or completeness. The use of this information or the implementation of any of these techniques is a customer responsibility and depends on the customer's ability to evaluate and integrate them into the customer's operational environment. While each item may have been reviewed by IBM for accuracy in a specific situation, there is no guarantee that the same or similar results will be obtained elsewhere. Customers attempting to adapt these techniques to their own environments do so at their own risk.

The following terms are trademarks of the International Business Machines Corporation in the United States and/or other countries:

AIX	AIX/ESA
AIX/6000	AIXwindows
AS/400	CICS
CICS/ESA	CICS/MVS
DATABASE 2	DB2
Enterprise System/9000	ES/9000
ESA/390	ESCON
graPHIGS	IBM
InfoExplorer	Micro Channel
OS/2	OS/400
Presentation Manager	PS/2
RACF	RISC System/6000
S/390	System/370

The following terms are trademarks of other companies:

AFS and Transarc are registered trademarks of the Transarc Corporation.

APOLLO is a registered trademark of the Hewlett-Packard Company.

AppleTalk is a trademark of Apple Computer Inc.

ARPANET was developed by the United States Department of Defense.

BSD is a trademark of the University of California, Berkeley.

C-bus is a trademark of Corollary, Inc.

Dasher 210 is a trademark of Data General Corporation.

DEC VT52, DEC VT100 and DEC VT220 are trademarks of the Digital Equipment Corporation.

DECnet is a trademark of the Digital Equipment Corporation.

Digital Press is a trademark of the Digital Equipment Corporation.

Domain is a trademark of the Hewlett-Packard Company.

EtherLink is a trademark of the 3COM Corporation.

EtherLink/MC is a trademark of the 3COM Corporation.

3Com is a trademark of the 3COM Corporation.

HP and Hewlett Packard are trademarks of Hewlett Packard Corporation.

HYPERchannel is a trademark of the Network Systems Corporation.

IEEE is a trademark of the the Institute of Electrical and Electronics Engineers, Inc.

Interlink is a registered trademark of Interlink Computer Sciences, Incorporated.

IPX, Internet Packet Exchange and Novell are trademarks of Novell Inc.

Kerberos is a trademark of the Massachusetts Institute of Technology.

LSI/11 is a trademark of the Digital Equipment Corporation.

MCI is a trademark of MCI Communications Corporation.

Microsoft is a trademark of Microsoft Corporation.

NCS is a trademark of the Hewlett-Packard Company.

NDIS is a trademark of 3Com Corporation/Microsoft Corporation.

Network Computing System is a trademark of the Hewlett-Packard Company.

Network Computing Kernel is a trademark of the Hewlett-Packard Company.

Network File System and NFS are trademarks of SUN Microsystems, Inc.

NIC and NICps/2 are trademarks of Ungermann-Bass.

OSF/Motif is a registered trademark of Open Software Foundation, Inc.

OSF is a trademark of Open Software Foundation, Inc.

PC Direct is a trademark of Ziff Communications Company and is used by IBM Corporation under license.

Portmapper is a trademark of SUN Microsystems, Inc.

PostScript is a trademark of Adobe Systems, Inc.

Project Athena is a trademark of the Massachusetts Institute of Technology.

SNS/SNA Gateway is a trademark of Interlink Computer Sciences, Incorporated.

SUN Microsystems is a trademark of SUN Microsystems, Inc.

Telenet is a trademark of GTE Telenet Communication Corporation.
Ungermann-Bass is a trademark of Ungermann-Bass Corporation.
UNIX is a registered trademark in the United States and other countries licensed exclusively through X/Open Company Limited.
VT52, VT100, VT102, VT200, VT220 are trademarks of the Digital Equipment Corporation.
Western Digital is a trademark of the Western Digital Corporation.
Windows is a trademark of Microsoft Corporation.
Xerox and XNS are trademarks of the Xerox Corporation.
X/Open is a trademark of X/Open Company Limited.
X Window System and X Windows are trademarks of the Massachusetts Institute of Technology.

Other trademarks are trademarks of their respective companies.

Acknowledgments

The authors for this edition were:

Eamon Murphy International Technical Support Organization, Raleigh Center

Matthias Enders IBM Germany

Steve Hayes IBM UK

This publication is the result of a residency conducted at the International Technical Support Organization, Raleigh Center.

Thanks to the following people for the invaluable advice and guidance provided in the production of this document:

Antonius Bekker EMEA Education, Raleigh

Edward Britton TCP/IP Technology, Strategy and Cross Product, Raleigh

Pete Haverlock NS Technical Support Center, Cary

Alfred Christensen International Technical Support Organization, Raleigh Center

Barry Nusbaum International Technical Support Organization, Raleigh Center

Contributors to earlier editions of this book were:

Gerard Bourbigot IBM France

Frank Vandewiele IBM Belgium

Bob Botts New Mexico Branch Office, Albuquerque
Richard Ryniker IBM Research, Yorktown Heights
Bruce Wilder TCP/IP Development, Raleigh
Ricardo Haragutchi IBM Brazil
Jim Curran TCP/IP Development, Raleigh
Paul D. Bosco Network Systems Architecture and Hardware in
Advanced Solutions Developed, Milford
Frederic Debulois IBM France
Francis Li IBM Canada
Niels Christiansen International Technical Support Organization, Austin
Center
**Philippe Beaupied, Lesia Antonowytch Cox, Peter Frick, Carla Sadtler, Dave
Shogren** International Technical Support Organization,
Raleigh Center
TCP/IP Development, Raleigh
The staff of the International Technical Support Organization, Rochester Center
Telecommunications Education Center, Raleigh

Chapter 5. Connections

This chapter describes the connectivity options available to the various IBM TCP/IP products. Each section presents a different connectivity option and its support for the TCP/IP products. The last section contains a summary.

5.1 IBM 3172 Interconnect Controller

The IBM 3172 Interconnect Controller can be configured as a LAN gateway, an offload gateway or a remote channel-to-channel controller, to provide high-performance interconnection from the S/370 and S/390 hosts to the LAN environments.

The following tables show the various connections supported by the three models of the 3172.

Host Software	Type of LAN				
	Ethernet V2	IEEE 802.3	Token-Ring	PCNET	FDDI
TCP/IP VM V2.3	all	all	all	1	2+3
TCP/IP MVS V3.1	all	all	all	1	2+3
AIX/ESA V2.2	all	all	all		2+3

all = 3172 Model 1, 2 & 3

Figure 5-1. LAN Types Supported on the 3172 with Interconnect Control Program (ICP)

Host Software	Type of LAN				
	Ethernet V2	IEEE 802.3	Token-Ring	PCNET	FDDI
TCP/IP VM V2.3					
TCP/IP MVS V3.1	X	X	X		X
AIX/ESA V2.2					

Figure 5-2. LAN Types Supported on the 3172-3 with the Offload Feature

Notes:

1. ICP stands for the 3172 Interconnect Control Program Version 3.3 which runs in the 3172 hardware.
2. Offload stands for OS/2 V2.11, TCP/IP Version 2.0 for OS/2, and the 3172-3 Offload hardware feature.
3. The 3172-1 and -3 connect to the host via either a parallel channel adapter or an ESCON channel adapter.
4. The 3172-2 connects to the host via a parallel channel adapter.
5. The 3172 with ICP supports other host software, such as SNA VTAM, OSI/CS and DECnet (please refer to the *IBM 3172 Planning Guide* for details).

Both the MVS and VM TCP/IP provide the SNMP subagent functions for the 3172 running ICP. They also provide 3172-specific MIB support.

5.1.1 3172 TCP/IP Offload

The 3172 Model 3 can be configured to provide an Offload function to the TCP/IP for MVS Version 3.1. This function offloads some of the TCP/IP processing from the MVS host to the 3172. The current estimates show that this function can achieve 30% reduction in the host CPU cycles.

This configuration of the 3172-3 requires OS/2 V2.11 (OS/2 SE V1.3.2 is also supported, but OS/2 V2.11 is recommended), TCP/IP Version 2.0 for OS/2, the TCP/IP MVS Offload feature, the 3172-3 Offload hardware feature and the appropriate hardware adapters.

The 3172-3 is channel-attached to the MVS host, using one subchannel pair. The TCP/IP MVS offload processing uses the CLAW (Common Link Access for Workstation)

protocol for communicating between the TCP/IP MVS host and the 3172-3 Offload host. Two logical links are used over the subchannel pair (please see Figure 5-3 on page 5-4):

1. An **API link**

All TCP, UDP and IP header processing for the data transferred to and from the MVS host is performed in the 3172-3. The data is passed, via the API link, directly to the API interface on the TCP/IP MVS host, bypassing the IP, TCP and UDP layers on the TCP/IP MVS host.

2. An **IP link**

Other datagrams not destined for the MVS host are routed by the IP layer of the TCP/IP MVS host over the IP link.

CLAW is designed to achieve two goals:

1. All 370 subchannels driven by CLAW should remain 100% busy for as long as there is data transfer between the MVS host and the Offload host.
2. No 370 I/O interrupts should occur as long as the TCP/IP address space is not in an idle state.

This implies that the MIH (Missing Interrupt Handler) must be disabled for the subchannel pair used by the offload processing; otherwise, a channel interrupt will cause the CLAW algorithm to fail.

TCP/IP MVS creates and updates the routing table on the offload 3172-3 based on its own routing table.

Note: Since the 3172-3 offload function handles all ICMP packets, it responds to ICMP echo requests (from ping, for example) even if TCP/IP MVS is not running.

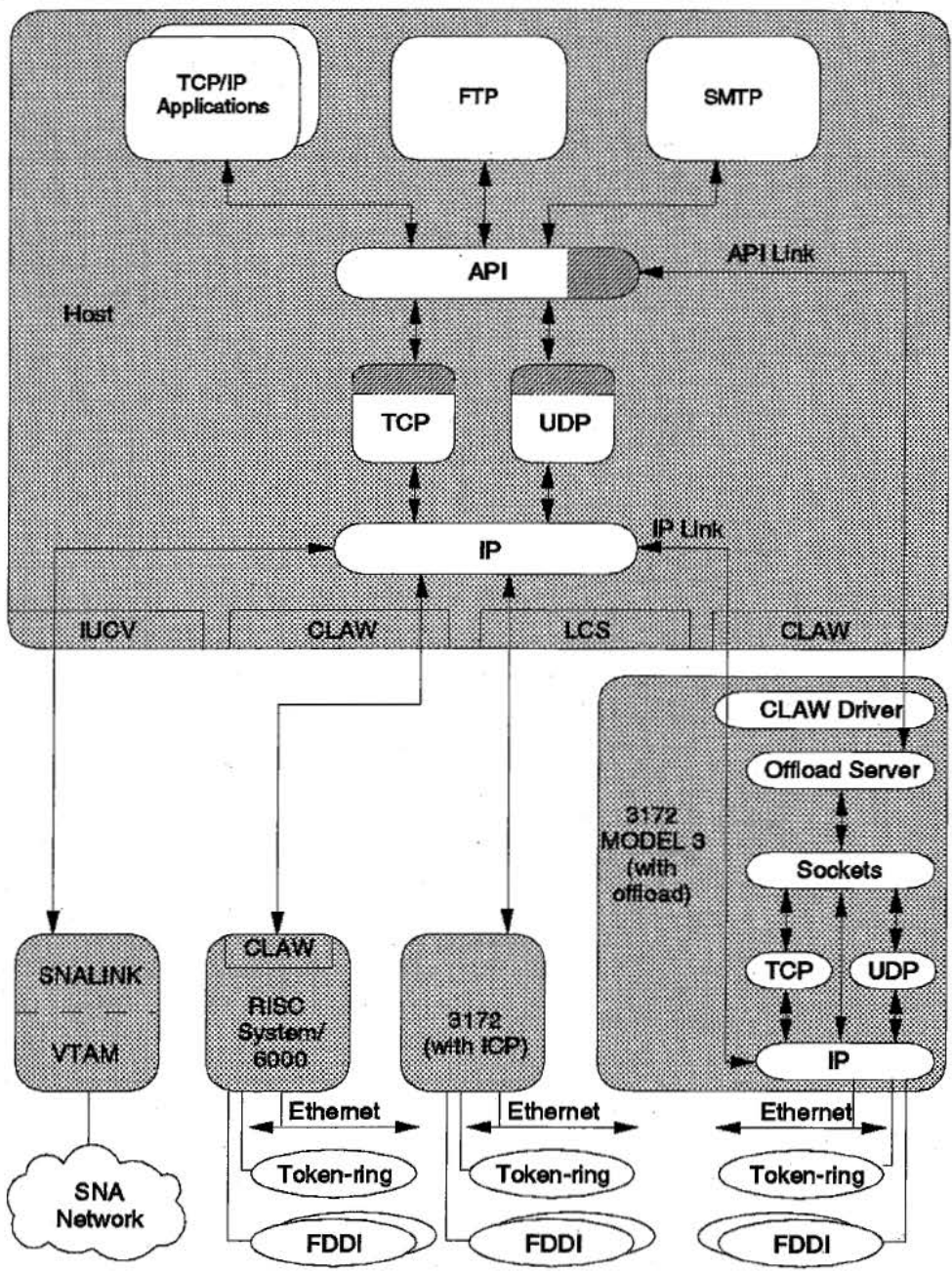

Figure 5-3. IBM 3172-3 Interconnect Controller. TCP/IP Offload Processing.

For more details on TCP/IP Offload processing, please refer to the *IBM TCP/IP Version 3 Release 1 for MVS: Offload of TCP/IP Processing*.

5.2 HYPERchannel Adapter

HYPERchannel A is a 50 Mbps, baseband, CSMA with collision avoidance network using a coaxial bus cable. Each network adapter can control up to four trunks (coaxial cable). It is used to interconnect large mainframe computers and high-speed peripherals. This adapter has to be connected to a BLKMPXR channel. It appears as a 64-address control unit to the operating system.

Both TCP/IP for VM and TCP/IP for MVS support HYPERchannel Series A devices. In addition, TCP/IP for VM and MVS supports the HYPERchannel Series DX devices, provided they function as Series A devices.

AIX/ESA supports the HYPERchannel Series DX devices.

TCP/IP for VM and TCP/IP for MVS support the HYPERchannel adapter A220, using the 16-bit address mode.

5.2.1 Addressing Particularities

Unlike most datagram delivery systems, the HYPERchannel network message consists of two parts. The first part is a message header, containing information required for the delivery. The second part is the associated data. Its length is literally unlimited. The header consists of several fields, each of them giving a value for TO and FROM trunks, adapters, and ports. The corresponding protocol does not support link-level broadcast, and therefore neither the Address Resolution Protocol (ARP) nor the IP broadcast can be used.

Connected to IBM channels, the entire logical TO field is interpreted as the subchannel on which the incoming data is to be presented.

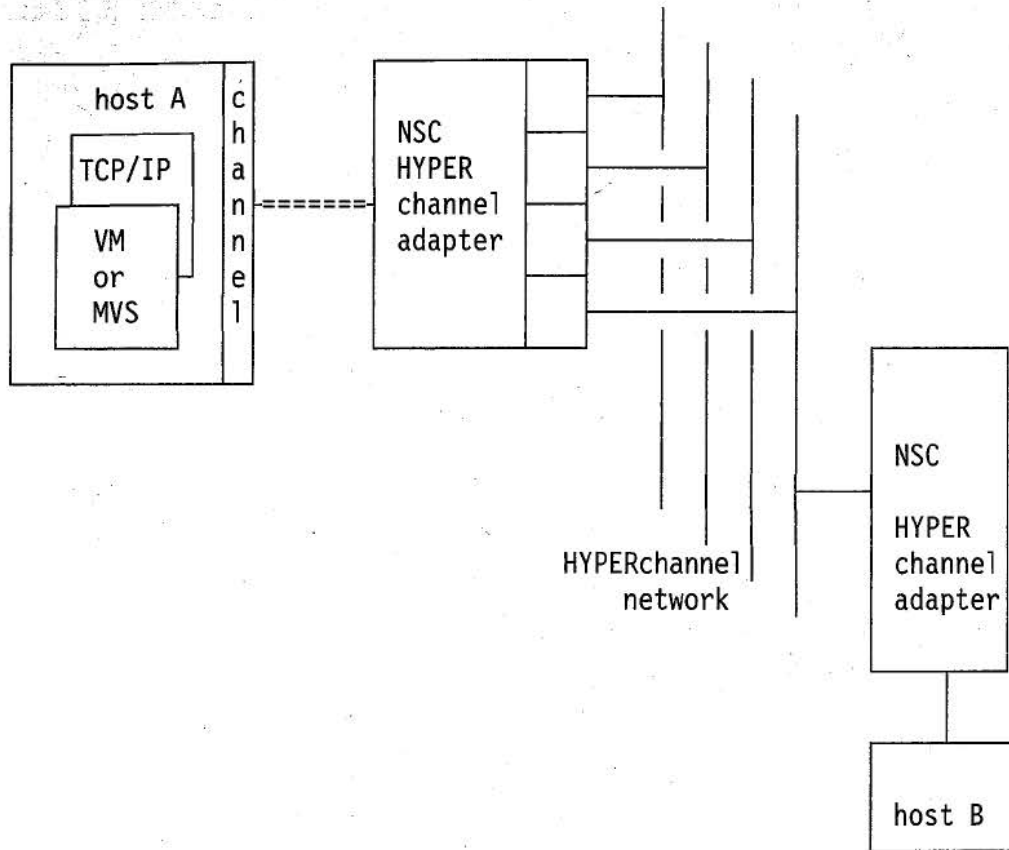

Figure 5-4. HYPERchannel Network

For more information on HYPERchannel contact your Network Systems Corporation representative.

5.3 The IBM High-Performance Parallel Interface (HIPPI)

The IBM High-Performance Parallel Interface (HIPPI) is an 800 Mbps data transfer device that operates in a variety of high-speed computer environments. It is an implementation of the ANSI X3.183-1991 High-Performance Parallel Interface (HIPPI-PH) standard.

The IBM HIPPI can attach devices that comply with the ANSI standard to selected members of the IBM Enterprise System/3090 (ES/3090) and IBM Enterprise System/9000 (ES/9000) family of computers. Some examples of these devices are high-resolution real-time visualization devices, file servers, workstations or supercomputers.

5.3.1 Implementations

5.3.1.1 MVS

One of the following hardware RPQs is required for the HIPPI-supported ES/3090 or ES/9000 family of computers: 8P1347, 8P1348, 8P1353 or 8P1354.

The HIPPI software (RPQ P88039, program number 5799-DKW) makes the function of the HIPPI available to the HIPPI application programs. MVS TCP/IP V3R1 is one such program.

The IBM HIPPI software actually provides both a high-level, multiplexing interface and a low-level, exclusive-use interface. Basically, the high-level multiplexed interface gives several applications the ability to use HIPPI at the same time. This interface complies with the ANSI HIPPI-FP framing protocol. The low-level, exclusive-use interface allows only a single application to establish an association with it.

Note: MVS TCP/IP V3R1 was implemented to use the low-level interface. This means that other software may not use HIPPI while MVS TCP/IP is using it.

Please see Figure 5-5 for an overview of the relationship of the various components.

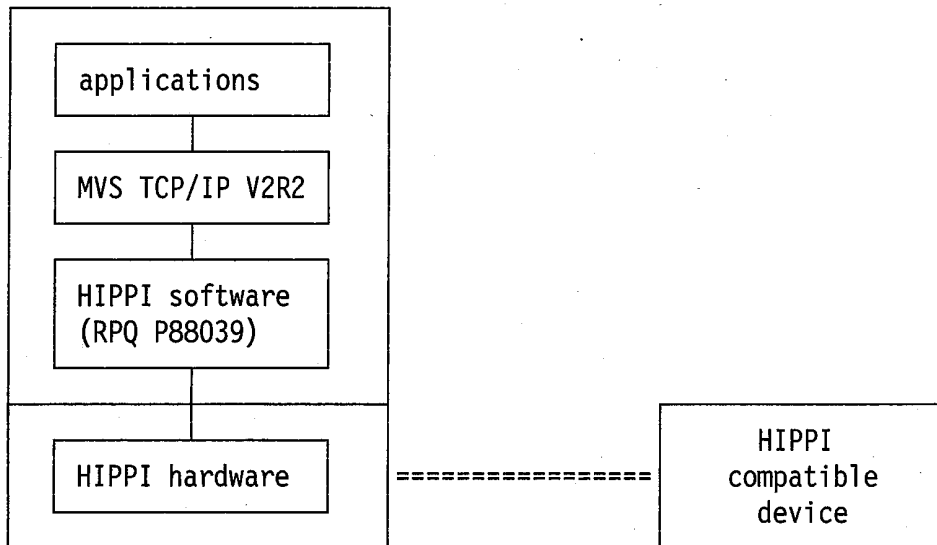

Figure 5-5. IBM HIPPI and MVS TCP/IP

5.3.2 HIPPI Draft Standards and Internet-Draft

The ANSI X3T9.3 HIPPI working group drafted four standards covering:

- (HIPPI-PH) the physical and electrical specification
- (HIPPI-FP) the framing protocol of a point-to-point interface
- (HIPPI-LE) the encapsulation of IEEE 802.2 LLC data packets
- (HIPPI-SC) the control of HIPPI physical layer switches

Please see Figure 5-6 for an overview of the relationship of the various ANSI draft standards.

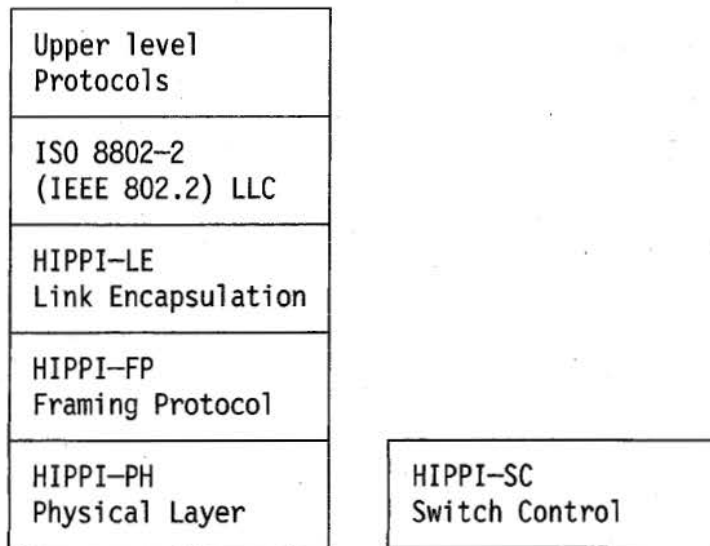

Figure 5-6. Relationship of ANSI HIPPI Draft Standards

The Internet-Draft "IP and ARP on HIPPI" by A. Nicholson, June 1992, describes the HIPPI interface between a host and a crosspoint switch that complies with the HIPPI-SC draft standard. This is a *working draft* which is intended to become an Internet standard in the future.

Note: The HIPPI-SC switches are devices which allow a single HIPPI device to switch between multiple HIPPI devices without involving protocols above the HIPPI-PH layer.

5.3.3 Relationship of IBM HIPPI and the ANSI Draft Standards

The current IBM HIPPI does not support two items in the ANSI draft standard X3.183-1991 (HIPPI-PH):

- The IBM HIPPI does not support microbursts. Data is exchanged in packet sizes that are integral multiples of 4096 bytes.
- The IBM HIPPI does not have a means for software to deactivate the REQUEST signal of the IBM outbound channel once a program activates REQUEST by setting the clear bit in the outbound control word.

Please refer to *IBM HIPPI User's Guide and Programmer's Reference* for details.

5.4 CTC (Channel To Channel)

Both TCP/IP for MVS and TCP/IP for VM support the CTC (Channel-to-Channel, 3088) for S/370 host interconnection. The CTC device driver uses the CTC-to-transport IP packets without using VTAM and has a substantial performance benefit over SNALINK (see 5.6, "SNALINK" on page 5-11).

5.5 Continuously Executing Transfer Interface (CETI)

The CETI interface allows communication from S/370 and ESA/390 hosts to all other IEEE 802.3, Ethernet Version 2, and IEEE 802.5 LAN-attached hosts, controllers, workstations and devices where matching line protocols are available. This includes the attachment of non-IBM network controllers.

The CETI interface minimizes the use of SIO instructions and I/O interruptions in the S/370 and ESA/390 host processors.

For more details about the CETI and its relationship to the S/370 and ESA/390 software on the S/370 and ESA/390 *channel command* base, please refer to *ES/9000 Token-Ring and IEEE 802.3 LAN Programming Information*. Figure 5-7 on page 5-10 shows an overview of the CETI environments.

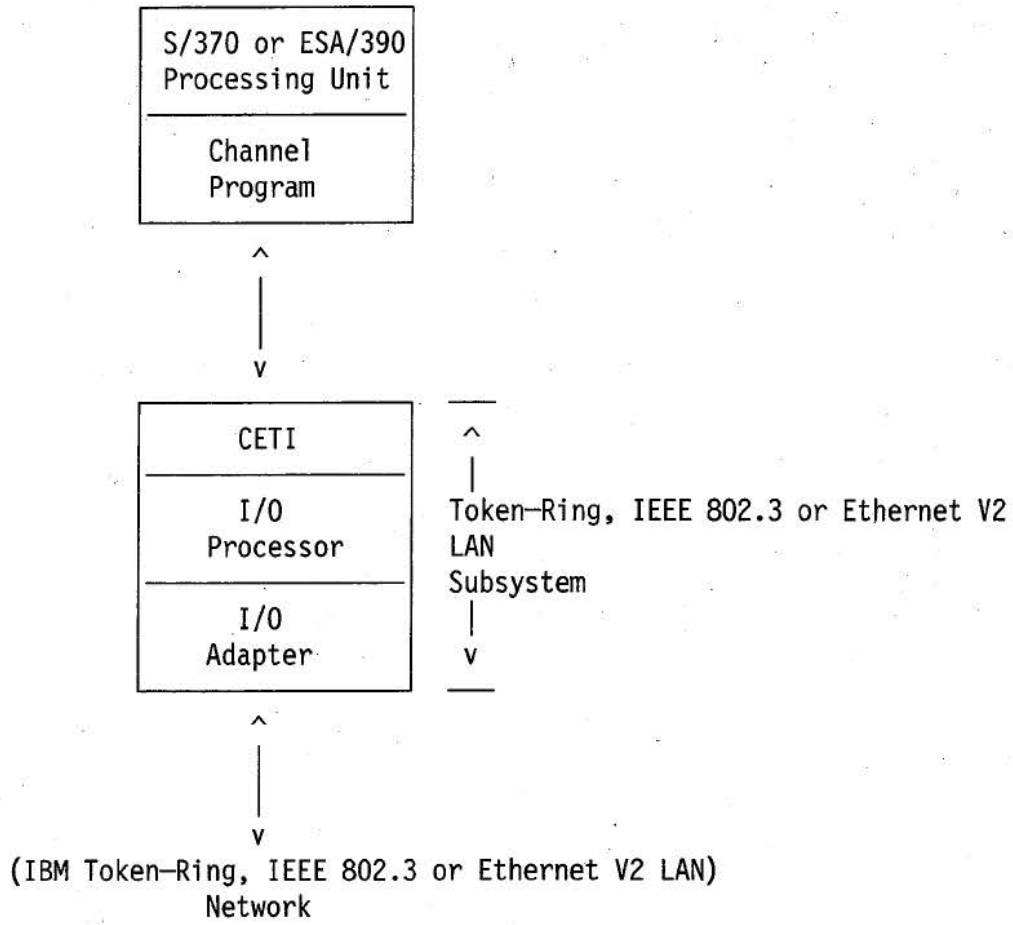

Figure 5-7. Ceti Connection

5.5.1 Implementations

TCP/IP for MVS supports the Ceti.

For information about Ceti support in TCP/IP for MVS, please refer to *IBM TCP/IP Version 3 Release 1 for MVS: Customization and Administration Guide*.

5.6 SNALINK

Both TCP/IP for VM and TCP/IP for MVS are implemented with the SNAlink function. This function allows the use of an SNA backbone to transfer TCP/IP protocols. A system equipped with TCP/IP and VTAM can be an originator, destination, or router of data originating from such a system.

In order to use this function of TCP/IP, you must have VTAM and TCP/IP installed on each host to be connected via SNAlink. There are two types of SNAlink implementations:

1. SNALINK, a VTAM application using the VTAM LU 0 protocol
2. SNALNK62, a VTAM application using the VTAM LU 6.2 protocol

Both SNALINK and SNALNK62 run in a separate address space (in MVS) or virtual machine (in VM) and are used to communicate between TCP/IP and VTAM. (Please see Figure 5-8 on page 5-12.) Both communicate with TCP/IP using IUCV.

SNALINK communicates via VTAM to its SNALINK partner on the remote host using the LU 0 protocol.

SNALNK62 communicates via VTAM to its SNALNK62 partner on the remote host using the LU 6.2 protocol.

For more details, please refer to the *IBM TCP/IP Version 3 Release 1 for MVS: Customization and Administration Guide* and *IBM TCP/IP Version 2 Release 3 for VM: Planning and Customization*.

TCP/IP for OS/2 provides support for an SNAlink LU 6.2 connection in its Extended Networking Kit. For more information refer to *TCP/IP V2.0 for OS/2 Extended Networking Guide, SC31-7071*.

Note that there is an Internet-Draft describing a method for the transmission of IP over SNA LU6.2. For details, please see [Stevenson, Schwell and Siddall] listed in Appendix A, "Bibliography" on page A-1.

5.6.1 Example

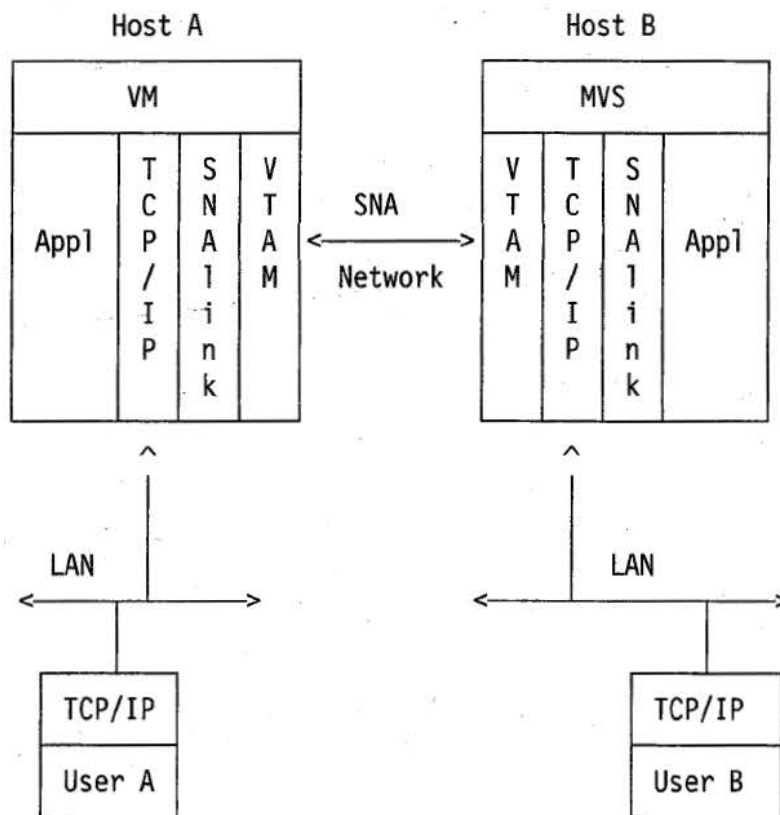

Figure 5-8. Principle of SNAlink Function

From a workstation connected to a LAN using basic TCP/IP functions, User A can access applications on Host A. In addition, User A can *TELNET* or *FTP*, via the Host A (transparently using the SNAlink function through a SNA backbone) to Host B.

5.7 Fiber Distributed Data Interface (FDDI)

The FDDI specifications define a family of standards for 100 Mbps fiber optic LANs that provides the physical layer and media access control sublayer of the data link layer as defined by the ISO/OSI Model.

IP-FDDI is a *draft standard protocol*. Its status is *elective*. It defines the encapsulating of IP datagrams and ARP requests and replies in FDDI frames. Figure 5-9 on page 5-13 shows the related protocol layers.

It is defined in *RFC 1188 - A Proposed Standard for the Transmission of IP Datagrams over FDDI Networks* for single MAC stations. Operation on dual MAC stations will be described in a forthcoming RFC.

RFC 1188 states that all frames are transmitted in standard IEEE 802.2 LLC Type 1 Unnumbered Information format, with the DSAP and SSAP fields of the 802.2 header set to the assigned global SAP value for SNAP (decimal 170). The 24-bit Organization Code in the SNAP header is set to zero, and the remaining 16 bits are the EtherType from Assigned Numbers (see RFC 1340), that is:

- 2048 for IP
- 2054 for ARP

The mapping of 32-bit Internet addresses to 48-bit FDDI addresses is done via the ARP dynamic discovery procedure. The broadcast Internet addresses (whose <host address> is set to all ones) are mapped to the broadcast FDDI address (all ones).

IP datagrams are transmitted as series of 8-bit bytes using the usual TCP/IP transmission order called "big-endian" or "network byte order".

The FDDI MAC specification (*ISO 9314-2 - ISO, Fiber Distributed Data Interface - Media Access Control*) defines a maximum frame size of 4500 bytes for all frame fields. After taking the LLC/SNAP header into account, and to allow future extensions to the MAC header and frame status fields, the MTU of FDDI networks is set to 4532 bytes.

Please refer to *LAN Concepts and Products*, GG24-3178 for more details on the FDDI architecture.

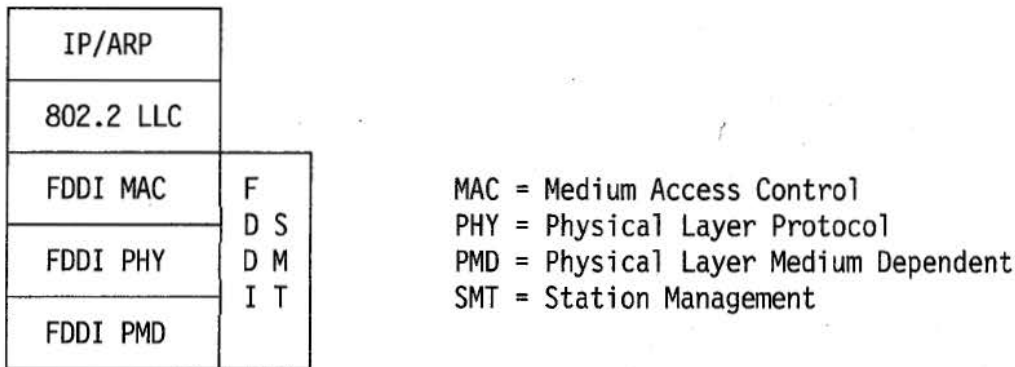

Figure 5-9. IP and ARP over FDDI

5.7.1.1 Implementations

TCP/IP for MVS, TCP/IP for VM, and TCP/IP for AIX/ESA all support the FDDI Controller.

AIX/6000 supports FDDI connectivity through the RISC System/6000 Fiber Distributed Data Interface (FDDI) and the RISC System/6000 Serial Optical Channel Converter (SOCC) adapters.

5.8 Serial Line IP (SLIP)

The TCP/IP protocol family runs over a variety of network media: IEEE 802.3 and 802.5 LANs, X.25 lines, satellite links, and serial lines. Standards for the encapsulation of IP packets have been defined for many of these networks, but there is no standard for serial lines. SLIP is currently a *de facto* standard, commonly used for point-to-point serial connections running TCP/IP. It is not an Internet standard.

SLIP is just a very simple protocol designed quite a long time ago and is merely a packet framing protocol. It defines a sequence of characters that frame IP packets on a serial line, and nothing more. It does not provide any:

- Addressing: both computers on a SLIP link need to know each other's IP address for routing purposes.
- Packet type identification: thus, only one protocol can be run over a SLIP connection.
- Error detection/correction: error detection is not absolutely necessary at the SLIP level because any IP application should detect corrupted packets (IP header and UDP/TCP checksums should be sufficient). Because it takes so long to retransmit a packet that was altered, it would be efficient if SLIP could provide some sort of simple error correction mechanism of its own.
- Compression.

The SLIP protocol is expected to be replaced by the Point-to-Point Protocol (PPP). Please see 5.9, "Point-to-Point Protocol (PPP)" on page 5-15.

5.8.1 Implementations

SLIP is implemented in TCP/IP for OS/2, TCP/IP for DOS, and in AIX/6000.

5.8.2 Example

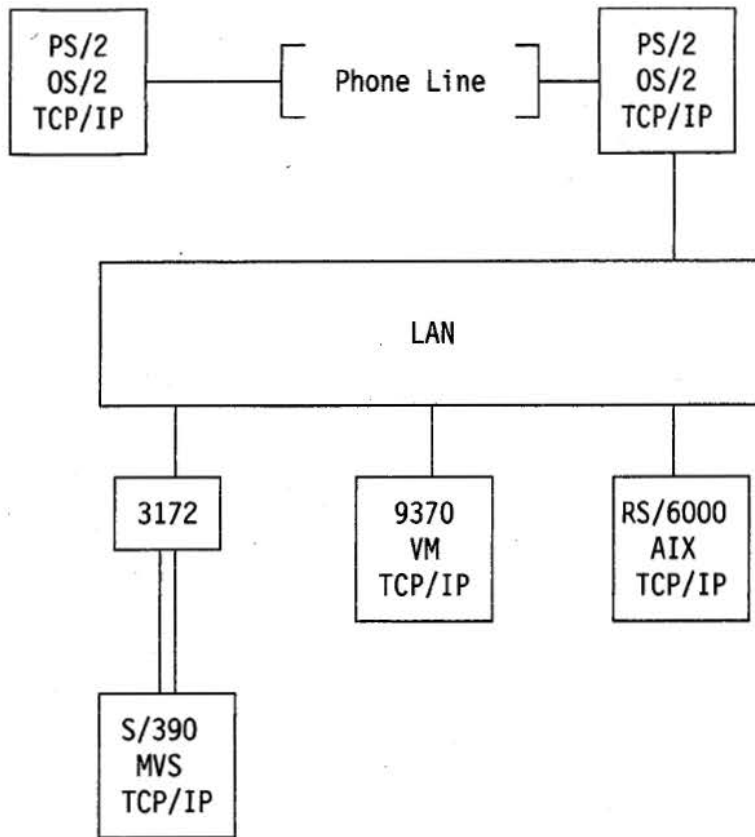

Figure 5-10. SLIP Example

In Figure 5-10, the OS/2 workstation, connected to the LAN using a SLIP connection, can access all the other workstations, assuming that the necessary routing information has been set up. Conversely, all the workstations and hosts connected to the LAN can access the OS/2.

5.9 Point-to-Point Protocol (PPP)

PPP is a *network-specific standard protocol* with STD number 51. Its status is *elective*. It is described in RFC 1661 and RFC 1662.

There are a large number of *proposed standard protocols* which specify the operation of PPP over different kinds of point-to-point link. Each has a status of *elective*. The reader is advised to consult *STD 1 — Internet Official Protocol Standards* for a list of PPP-related RFCs which are on the Standards Track.

Point-to-Point circuits in the form of asynchronous and synchronous lines have long been the mainstay for data communications. In the TCP/IP world, the de facto standard SLIP protocol has served admirably in this area, and is still in widespread use for dial-up TCP/IP connections. However, SLIP has a number of drawbacks:

- SLIP defines only the encapsulation protocol, not any form of handshaking or link control. Links are manually connected and configured, including the specification of the IP address.
- SLIP is only defined for asynchronous links.
- SLIP cannot support multiple protocols across a single link; all packets must be IP datagrams.
- SLIP does no form of frame error detection which forces re-transmission by higher level protocols in the case of errors on noisy lines.
- SLIP provides no mechanism for compressing frequently used IP header fields. Many applications over slow serial links tend to be single-user interactive TCP traffic such as TELNET. This frequently involves small packet sizes and therefore a relatively large overhead in TCP and IP headers which do not change much between datagrams, but which can have a noticeably detrimental effect on interactive response times.

However, many SLIP implementations now use *Van Jacobsen Header Compression*. This is used to reduce the size of the combined IP and TCP headers from 40 bytes to 8 bytes by recording the states of a set of TCP connections at each end of the link and replacing the full headers with encoded updates for the normal case where many of the fields are unchanged or are incremented by small amounts between successive IP datagrams for a session. This compression is described in RFC 1144.

The Point-to-Point protocol addresses these problems.

PPP has three main components:

1. A method for encapsulating datagrams over serial links.
2. A *Link Control Protocol (LCP)* for establishing, configuring, and testing the data-link connection.
3. A family of *Network Control Protocols (NCPs)* for establishing and configuring different network-layer protocols. PPP is designed to allow the simultaneous use of multiple network-layer protocols.

Before a link is considered to be ready for use by network-layer protocols, a specific sequence of events must happen. The LCP provides a method of establishing, configuring, maintaining and terminating the connection. LCP goes through the following phases:

1. Link establishment and configuration negotiation:

In this phase, link control packets are exchanged and link configuration options are negotiated. Once options are agreed upon, the link is *open*, but not necessarily *ready* for network-layer protocols to be started.

2. Link quality determination:

This phase is optional. PPP does not specify the policy for determining quality, but does provide low-level tools, such as echo request and reply.

3. Authentication:

This phase is optional. Each end of the link authenticates itself with the remote end using authentication methods agreed to during phase 1.

4. Network-layer protocol configuration negotiation:

Once LCP has finished the previous phase, network-layer protocols may be separately configured by the appropriate NCP.

5. Link termination:

LCP may terminate the link at any time. This will usually be done at the request of a human user, but may happen because of a physical event.

The *IP Control Protocol (IPCP)* is the NCP for IP and is responsible for configuring, enabling and disabling the IP protocol on both ends of the point-to-point link. The IPCP options negotiation sequence is the same as for LCP, thus allowing the possibility of reusing the code.

One important option used with IPCP is *Van Jacobsen Header Compression* which is used to reduce the size of the combined IP and TCP headers from 40 bytes to approximately 4 by recording the states of a set of TCP connections at each end of the link and replacing the full headers with encoded updates for the normal case where many of the fields are unchanged or are incremented by small amounts between successive IP datagrams for a session. This compression is described in RFC 1144.

5.10 TCP/IP and X.25

IP-X25 is a *standard protocol*. Its status is *elective*.

For detail on the Internet Protocol on X.25 networks, please refer to RFC 877 and RFC 1356.

5.10.1 Implementations

MVS, VM, OS/2, OS/400 and AIX/6000 all support TCP/IP over X.25 networks.

5.10.1.1 MVS

The TCPIPX25 address space runs a VTAM application program called XNX25IPI, which is the interface between the TCPIP address space's IUCV driver and your X.25 network. XNX25IPI communicates with the NPSI (X.25 NCP Packet Switching Interface) in a front-end IBM 37XX Communications Controller.

For more details, please refer to the *IBM TCP/IP Version 3 Release 1 for MVS: Customization and Administration Guide* and *X.25 Network Control Program Packet Switching Interface Planning and Installation*.

5.10.1.2 VM

The X25IPI virtual machine runs a GCS (Group Control System) application program called X25IPI, which is the interface between the TCPIP virtual machine's IUCV driver and your X.25 network. X25IPI communicates with the NPSI (X.25 NCP Packet Switching Interface) in a front-end IBM 37XX Communications Controller.

For more details, please refer to the *IBM TCP/IP Version 2 Release 3 for VM: Planning and Customization* and *X.25 Network Control Program Packet Switching Interface Planning and Installation*.

The IBM 9370 X.25 Communication Subsystem Controller provides support for non-SNA users. It is designed to support communications between hosts running TCP/IP over an X.25 network. For more details, please refer to *IBM 9370 Information System X.25 Communications Subsystem Description*.

5.10.1.3 X.25 Scenario using the IBM 9370

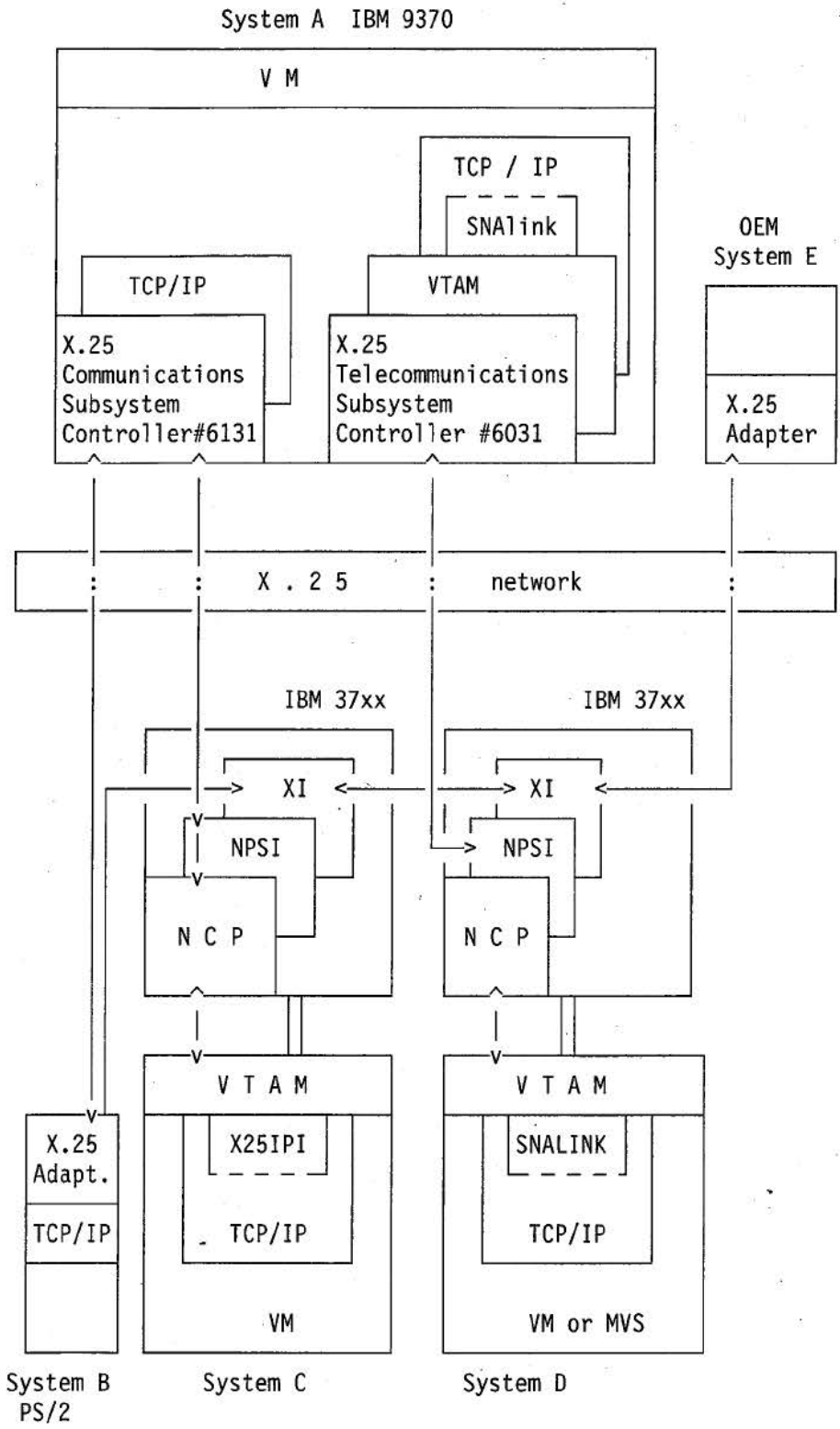

Figure 5-11. X.25 Example Scenario

Using the two 9370 adapters, XI, NPSI, and standard functions of TCP/IP, we may build a network allowing the following possibilities:

- From System A, a user can access System B using the IBM 9370 X.25 Communication Subsystem Controller supported by TCP/IP. This is transparent for the user doing a TELNET or FTP, which are standard functions of TCP/IP.
- From System A to System C, the user enters the SNA world by an access to NPSI. Then we are in the VTAM area. The link between VTAM and TCP/IP is realized by X25IPI, which is a virtual machine owned by TCP/IP.
- From System A to System D, the TCP/IP connection is an SNA link over an X.25 network. Viewed from TCP/IP, the physical network can be any one supported by SNA.
- System B and System E may be linked through XI capabilities.

Note: The X.25 Telecommunication Subsystem Controller integrated into the IBM 9370 is only supported by the Virtual Telecommunication Access Method (VTAM). It is designed as a part of System Network Architecture (SNA). On the other hand, the IBM 9370 X.25 Communication Subsystem Controller is supported only by TCP/IP.

5.11 3745 and Ethernet Adapter

The 3745 when installed with an ESS (3745 Ethernet SubSystem), and running the NCP (Network Control Program) Version 6, support the routing of IP and ARP Ethernet traffic. Both Ethernet V2 and IEEE 802.3 frames are supported by the 3745 ESS. It supports communication from:

- Ethernet IP workstation/host to Ethernet IP workstation/host
- Ethernet IP workstation/host to VM/MVS TCP/IP host.

5.11.1 Principle of Operation

NCP IP routing uses SNA sessions to transport IP datagrams across an SNA backbone network. SNA sessions are established from NCP IP nodes to other NCP IP nodes and SNALINK TCP/IP hosts. IP datagrams are enveloped at an IP node into an SNA RU and sent across an SNA session to a destination NCP IP node or SNALINK TCP/IP host. The routing mechanism is based on static NCP routing tables. The destination NCP IP node or SNALINK TCP/IP host de-envelopes the IP datagrams and sends the frames to an Ethernet/802.3 LAN or a TCP/IP host subsystem respectively. NCP also supports the TCP/IP Address Resolution Protocol (ARP). IP traffic will benefit from NCP routing of IP within the SNA backbone network (error recovery, flow control, etc.).

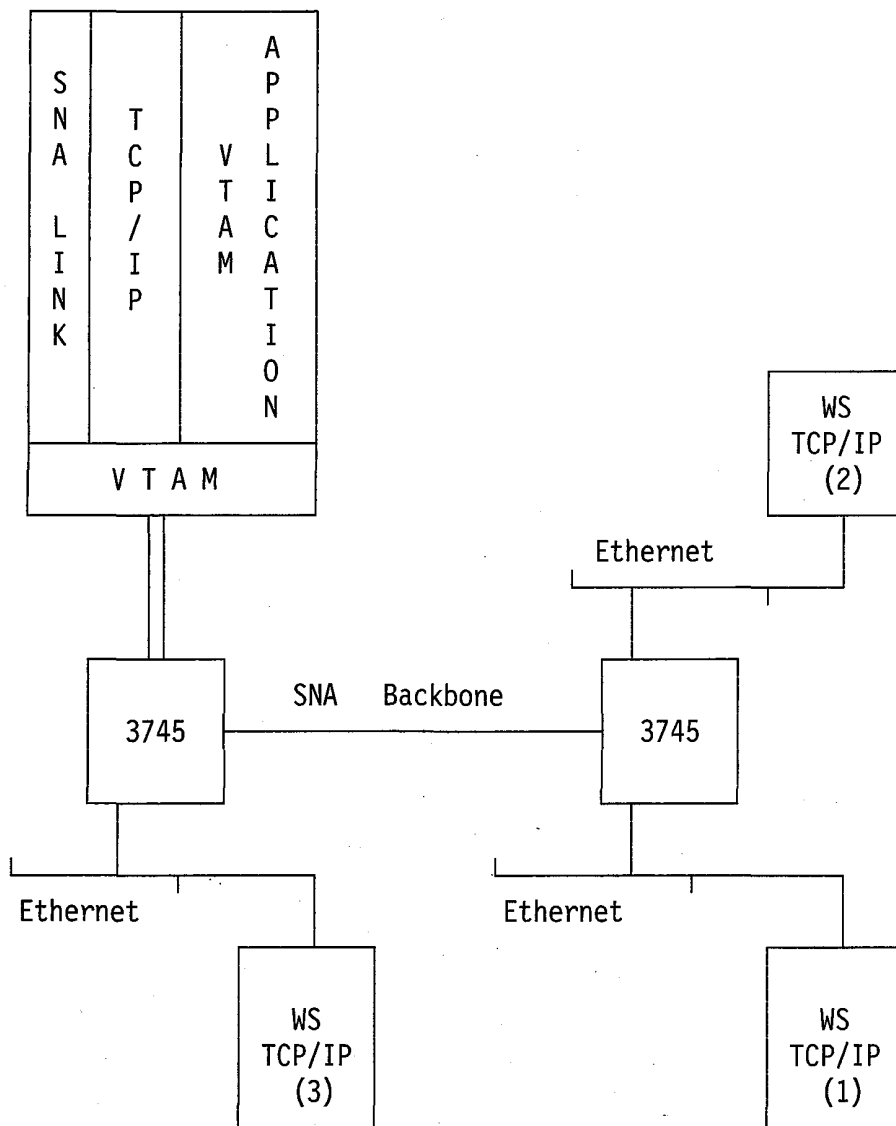

Figure 5-12. 3745 and Ethernet Adapter

5.11.2 Example

All the workstations can access a VTAM application in the host using TELNET.

All the workstations can access a TCP/IP application in the host (for example FTP).

Workstation 1 can communicate with workstation 2 (Ethernet-to-Ethernet in the same 3745).

Workstation 1 can communicate with workstation 3 (Ethernet-to-Ethernet in different 3745s using the SNA backbone).

5.12 3174 Establishment Controller

The IBM 3174 Establishment Controller Configuration Support-C Release 6 provides TCP/IP TELNET client support, to communicate with TCP/IP TELNET servers via its token-ring interface, for the following attached devices:

- 3270 CUT-mode terminals and ASCII display stations
- intelligent workstations coaxially attached (installed with either OS/2 with TCP/IP for OS/2, or DOS with TCP/IP for DOS and the IBM Workstation Peer Communication Support Program)

The TELNET hosts (servers) may be attached directly to the same token-ring which the 3174 is connected to, or they may exist anywhere in the network reachable via that token-ring and any bridges or routers. These TELNET hosts can also be non-IBM hosts that provide TELNET server support.

5.12.1.1 3174 Supported TELNET Terminal Types

For the coaxially attached display terminals, the 3174 supports the following 24x80 full-screen terminal types: IBM3101, DEC VT100, DEC VT220 and Data General D210.

For the ASCII-Emulation Adapter-attached ASCII display terminals, the 3174 passes the terminal data stream transparently to the TELNET server. This means that the TELNET server manages the display terminal as if it were a locally attached ASCII terminal.

The TELNET line mode is also supported for all displays.

In addition, TN3270 protocol support and Ethernet connectivity support are provided. TN3270 support allows the 3174 to support 3270 data stream traffic across TCP/IP links.

LPD and LPR printing functions are also supported.

5.13 PC and PS/2 Connections

5.13.1 Connections Supported by TCP/IP for OS/2

TCP/IP for OS/2 conforms to the Networks Device Interface Specification (NDIS) and has been tested with the following network adapters:

For Micro Channel workstations:

- IBM Token-Ring Network Adapter/A
- IBM Token-Ring Network 16/4 Adapter/A
- IBM Token-Ring Network Bus Master 16/4 Adapter
- IBM PC Network Adapter
- IBM 3174 Peer Communications Network Adapter
- IBM PS/2 Adapter/A for Ethernet Networks
- 3Com Etherlink/MC Network Adapter
- Western Digital Ethercard PLUS/A Adapter
- Ungerman-Bass NIUpc Network Adapter
- IBM X.25 Interface Coprocessor/2

For AT workstations:

- IBM Token-Ring Network Adapter
- IBM Token-Ring Network Adapter II
- IBM Token-Ring Network 16/4 Adapter
- IBM PC Network Adapter
- IBM 3174 Peer Communications Network Adapter
- 3Com Etherlink II Network Adapter
- Western Digital Ethercard PLUS Network Adapter
- Ungerman-Bass NIUpc Network Adapter
- Other adapters with NDIS Device Drivers

5.13.2 Connections Supported by TCP/IP for DOS

TCP/IP for DOS conforms to the Networks Device Interface Specification. The following connections and adapters are supported:

For PC AT, PS/2 Model 25 or 30 (EISA):

- IBM Token-Ring Network using:
 - IBM Token-Ring Network PC Adapter
 - IBM Token-Ring Network PC Adapter II
 - IBM Token-Ring Network 16/4 Adapter
 - IBM Token-Ring Network 16/4 Adapter II
- IBM PC Network using:

- IBM PC Network Adapter II
- IBM PC Network Baseband Adapter
- IBM PC Network Adapter II Frequency 2
- IBM PC Network Adapter II Frequency 3
- Ethernet Network using:
 - IBM LAN Adapter for Ethernet
 - 3Com Etherlink Adapter (Model 3C501)
 - 3Com Etherlink II Adapter (Model 3C503)
 - Western Digital Ethercard PLUS Adapter
 - Ungerman-Bass PC-NIC Adapter
 - Other Ethernet Network Adapters using Packet Device Drivers
- SLIP using:
 - Standard RS-232 compatible serial interface and a modem or a serial connection modem cable
- Coax using:
 - IBM 3270 Connection Card, or IBM 3278/3279 Emulation Adapter using IBM 3174 Peer Communications Support Program with NDIS

For PS/2 models with Micro Channel architecture:

- IBM Token-Ring Network using:
 - IBM Token-Ring Network Adapter/A
 - IBM Token-Ring Network 16/4 Adapter/A
- IBM PC Network using:
 - IBM PC Network Baseband Adapter/A
 - IBM PC Network Adapter II/A
 - IBM PC Network Adapter II/A Frequency 2
 - IBM PC Network Adapter II/A Frequency 3
- Ethernet Network using:
 - IBM LAN Adapter/A for Ethernet
 - IBM PS/2 Adapter/A for Ethernet Networks
 - IBM PS/2 Adapter/A for Ethernet Twisted Pair Networks
 - 3Com Etherlink/MC Adapter (Model 3C523)
 - Western Digital Ethercard PLUS/A Adapter
 - Ungerman-Bass NICps/2 Adapter
 - Other Ethernet Network adapters using NDIS Device Drivers or Packet Device Drivers
- SLIP using:
 - Standard RS-232 compatible serial interface and a modem or a serial connection modem cable
- Coax using:
 - IBM 3270 Connection Card, or IBM 3278/3279 Emulation Adapter using IBM 3174 Peer Communications Support Program with NDIS

5.14 AIX/ESA Connections

AIX/ESA provides support for the following connections:

- Channel-to-channel (CTC) using:
 - ESCON channels
 - 3088 Channel-to-Channel Adapter
 - S/370 CTC Adapter
- LAN connections using:
 - 8232 LAN Channel Station (token-ring, IEEE 802.3 and Ethernet V2)
 - 3172 Interconnect Controller Model 1 or 3 (token-ring, IEEE 802.3 and Ethernet V2, FDDI)
 - 3172 Interconnect Controller Model 2 (FDDI)
- HYPERchannel connection:
 - NSC HYPERchannel-DX devices (for example FDDI, Ethernet, T1, T3, and RISC System/6000 via the IBM Serial Optical Channel Converter)
- RISC System/6000 connections using:
 - Block multiplexer channel adapter (CLAW)
 - ESCON Control Unit Adapter (CLAW)

5.15 RISC System/6000 Connections

The RISC System/6000 provides support for the following connections:

- LAN connections (token-ring, Ethernet and FDDI) using:
 - Token-Ring High-Performance Network Adapter
 - Ethernet High-Performance LAN Adapter
 - Fiber Distributed Data Interface (FDDI) (single and dual ring)
- WAN connections:
 - 4-Port Multiprotocol Communications Controller
 - X.25 Interface Co-Processor/2
- Host connections (also see 5.15.1, “RISC System/6000 Parallel Channel Attachment” on page 5-26):
 - Block Multiplexor Channel Adapter
 - Serial Optical Channel Converter
 - RISC System/6000 ESCON Control Unit Adapter
It enables the connection to one or more System/390 host systems via ESCON channel using 3088 or CLAW.
- Asynchronous connections:
 - 8 and 16 Port Asynchronous Adapters (RS232 and RS422)
 - 64 Port Asynchronous Adapter (RS232)
 - 4 Port Multiprotocol Communications Controller (RS232, RS422, V.35, X.21)

5.15.1 RISC System/6000 Parallel Channel Attachment

The RISC System/6000 supports the RISC System/6000 Block Multiplexer Channel Adapter. This provides high-speed parallel attachment between the RISC System/6000 and ES/9000, 3090, 308X and 4381 systems. A programming interface is provided at the device driver level to AIX.

The adapter device driver communicates to the same CLAW (Common Link Access to Workstation) device driver in MVS and VM as the 3172-3 mentioned in 5.1.1, "3172 TCP/IP Offload" on page 5-2.

TCP/IP for MVS V3R1, TCP/IP for VM V2R3 and AIX/ESA all support this RISC System/6000 PCA.

For more details, please refer to *AIX Block Multiplexer Channel Adapter User's Guide and Programming Reference*.

5.15.2 RISC System/6000 ESCON Control Unit Adapter

The implementation of the ESCON Control Unit Adapter is very similar to the Block Multiplexer.

For more details, please refer to *Enterprise Systems Connection Adapter Guide and Service Information*.

5.16 The IBM Nways Router Family

IBM offers two different multiprotocol routers:

- IBM 6611 Nways Network Processor
Full function, multiprotocol, multiport router and bridge, based on IBM RISC technology.
- IBM 2210 Nways Multiprotocol Router
Full function, low cost, entry node for small workgroups or remote offices based on the MC68360 processor.

Following is a brief description of both routers and their major functions.

5.16.1 IBM 6611 Network Processor

This router is offered in four different models, 120, 125, 145 and 175. The second digit of the model number represents the number of available slots for network adapter cards. The model 120 is offered in 10 fixed configurations while all others can hold any of the following adapters:

- 2-Port Multi-Interface Serial Adapter
- 4-Port Multi-Interface Serial Adapter
- 2-Port Token-Ring Network 16/4 Adapter
- Multi-Interface Serial/Token-Ring Adapter
- 2-Port Ethernet Adapter
- Multi-Interface Serial/Ethernet Adapter
- 4-Port SDLC Adapter

For more details, please refer to *IBM 6611 Network Processor Introduction and Planning Guide*.

The software support of the 6611 is provided by the preloaded *IBM Multiprotocol Network Program 1.3 (MPNP 5648-016)*. It provides the following major protocol functions:

- TCP/IP
 - RIP, RIP V2 with variable subnet masking, OSPF, EGP, BGP, BOOTP request/reply forwarding for centrally located BOOTP server
- IPX
- DECnet (Phase IV and Phase IV-Prime)
- AppleTalk (Phase 2)
- Banyan VINES
- XNS
- Source-route bridging
- Transparent bridging
- Translational bridging
- Frame Relay
 - RFC 1490: Multiprotocol Interconnect over Frame Relay supported for all protocols
 - RFC 1293: InARP support for all protocols
- PPP

RFCs: 1171, 1331, 1332, 1333, 1548, 1549 and others for specific protocols.

All protocols are supported on PPP

Link quality monitoring is supported

- X.25
- SNA (over DLSw) and APPN
Integration of SNA and APPN in the multiprotocol network
- NetBIOS (over DLSw)

5.16.1.1 Configuration, Management and Maintenance

The *Configuration Program* enables you to create a 6611 configuration which defines the interfaces and protocols you want to run. This program runs on the AIX/6000, OS/2 and DOS Windows platform and provides a graphical user interface for easy configuration. After you have finished the configuration the program creates a diskette with the binary files for the 6611.

The *System Manager* provides menu-driven and command line interfaces to view statistics, perform problem determination, install and update software, access other nodes in the network or make configuration changes.

The SNMP agent includes the following major functions:

- All standard MIB II objects
- Enterprise-specific 6611 MIBs
- RFC 1493 - Definitions of Managed Objects for Bridges
- RFC 1525 - Definitions of Managed Objects for Source Routing Bridges
- TRAP generation and GET/SET support, for example, SNMP SET Activate/Deactivate APPN Ports

The IBM 6611 is fully interoperable with the IBM 2210 and routers from other vendors if they comply with the open standards.

The newest 6611 MIB is available from the anonymous FTP server:
<ftp://venera.isi.edu/mib> on the Internet.

For more details, please refer to *IBM Multiprotocol Network Program: User's Guide*.

5.16.2 IBM 2210 Nways Multiprotocol Router

This is a low-cost router with very rich functionality for branch office environments which need to be connected to the multiprotocol backbone of an enterprise. All

configurations offer at least one LAN and two serial ports. Optionally, there is an ISDN-BRI interface which became available in April 1995 in selected European countries and Japan. The planar board includes processor, memory and interfaces for LAN, WAN and ISDN. The hardware is preconfigured and reconfiguration is not possible. Table 5-1 gives you an overview of the different models and included interfaces. The models with larger memory should be considered for larger networks.

Table 5-1. IBM 2210 Model and Connectivity Offerings

Model	Dual Serial	Token Ring	Ethernet	2/4 MB flash/ DRAM	4/8 MB flash/ DRAM	ISDN
121	x	x		x		
122	x		x	x		
123	x	x			x	
124	x		x		x	
125	x	x		x		x
126	x		x	x		x
127	x	x			x	x
128	x		x		x	x

The IBM 2210 offers a variety of interfaces and connectivity options:

- Ethernet at 10 Mbps
- Token-ring at either 4 or 16 Mbps
- Serial ports for V.35/V.36 (9.6 kbps to 2.048 Mbps), EIA232-D/V.24 (4.8 Kbps to 19.2 Kbps and X.21 at speeds from 2.4 Kbps to 2.048 Mbps supporting PPP, Frame Relay, X.25 and SDLC
- ISDN Basic Rate Interface (BRI, 2B+D) supporting the commonly used S/T interface in Europe and Asia

For more information refer to the *IBM Nways 2210 Multiprotocol Router Planning and Setup Guide*.

All models are shipped preloaded with IBM's Nways Multiprotocol Routing Network Services program (5765-368). The current version is 1.1.0 which provides the following protocol support:

- TCP/IP
 - Routing with RIP or OSPF

- TCP/IP filtering based on TCP/UDP well-known ports to allow or deny a particular application for security reasons
- BOOTP request/reply forwarding
- Variable subnet masking
- Optional routing of IPX over PPP, Frame Relay, X.25, and LANs
- Optional routing of AppleTalk over PPP and LANs
- Bridging:
 - Source-Route Bridging (SRB) over token-ring
 - Transparent Bridging (TB) over Ethernet
 - Source-Route Transparent (SRT) bridging over token-ring
 - Translational bridging (transparent bridging and IBM 8209/8229 emulation) between remote token-rings and Ethernets
- Wide Area Network (WAN) protocols:
 - Point-to-Point Protocol (PPP)
 - Bandwidth reservation over PPP
 - Frame Relay
 - X.25, complies with CCITT 1980 and 1984 specifications
 - Synchronous Data Link Control (SDLC)
 - PU 2.0 or PU 2.1
- Data Link Switching (DLSw), RFC 1434
- SNA

5.16.2.1 Configuration, Management and Maintenance

The IBM 2210 comes with a configuration program similar to the IBM 6611. It runs on DOS/Windows, OS/2 and AIX platforms. This program aids you in configuring ports and software functions and allows you to make remote configuration changes while the 2210 is operational. All the configuration is done with an easy-to-use graphical user interface.

The SNMP agent includes the following:

- All standard MIB II objects
- Enterprise-specific 2210 MIBs for features like DLSw as well as Vital Product Data information
- RFC MIBs for protocols like PPP and Frame Relay

- TRAP generation and GET support

The IBM 2210 is fully interoperable with the IBM 6611.

The newest 2210 MIB is available from the anonymous FTP server:
ftp://venera.isi.edu/mib on the Internet.

For more details, please refer to *IBM Nways Multiprotocol Routing Network Services: Software User's Guide*.

- The product *AIX Router and Bridge Manager/6000* based on *NetView for AIX* provides a graphical user interface in order to manage both the 6611s and the 2210s in your network.

5.17 IBM 8229 Local Area Network Bridge

The IBM 8229 Bridge replaces the withdrawn IBM 8209 LAN Bridge.

There are three models available:

- Model 1: Providing a connection between two local token-ring segments
- Model 2: Providing a connection between a local token-ring segment and a local Ethernet segment
- Model 3: Providing a connection between a local token-ring segment and a remote token-ring segment via a WAN at speeds up to T1/E1

The IBM 8229 Local Area Network Bridge allows devices on an IBM token-ring LAN to communicate with devices on an Ethernet V2 or IEEE 802.3 LAN. The 8229 converts the data exchange between the two LANs. To a device on the token-ring LAN, the 8229 appears as a bridge to another token-ring LAN. The 8229 is functionally transparent to any device on the Ethernet V2 or IEEE 802.3 LANs.

In addition, the 8229:

- Supports Ethernet V2 and IEEE 802.3 traffic at the same time
- Supports either a 4 or a 16 Mbps token-ring LAN and does not affect communications between token-ring stations
- Supports the IBM LAN Network Manager and NetView/390 for network management (LLC Type 2)
- Provides an SNMP agent to support an SNMP manager like NetView for AIX with the following MIBs:
 - MIB II (RFC 1213)

- Standard Bridge MIB (RFC 1286)
- IBM Enterprise MIB
- Provides flash memory for code download
- Provides RS-232 port for out-of-band code download (XMODEM)
- Can be configured as the secondary bridge of the following IBM split bridges:
 - IBM Token Ring Bridge Program Version 2.2
 - IBM Remote Token-Ring Bridge/DOS Version 1.0
- Is rack mountable
- Provides isolation between the LANs so unnecessary Ethernet LAN activity does not intrude into the token-ring LAN environment and vice versa

Figure 5-13 shows a simple 8229 connection diagram.

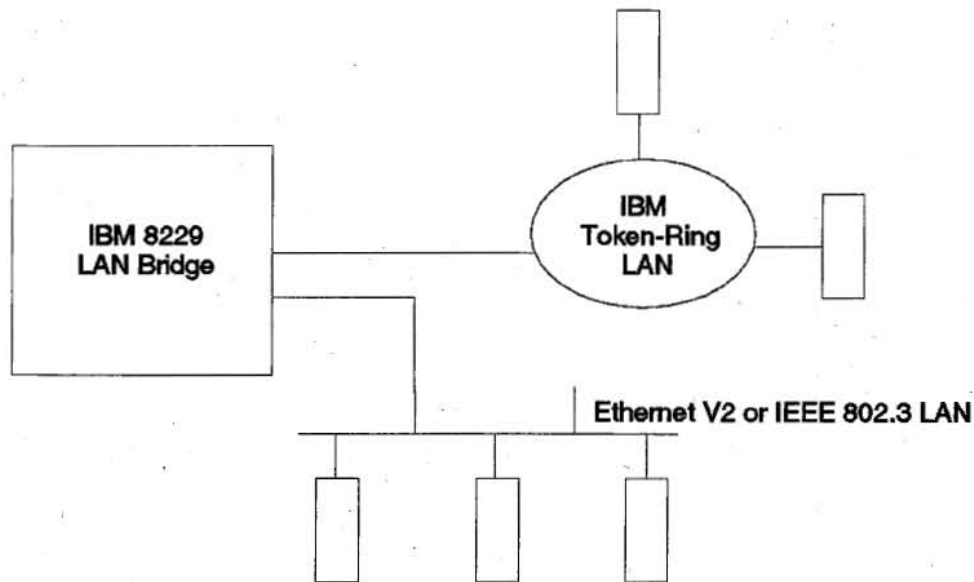

Figure 5-13. 8229 Connection Diagram

The 8229 is configured to operate in one of two modes:

- Mode 1 - When the 8229 is configured to operate in mode 1, performing subnetwork access protocol (SNAP) header processing, the TCP/IP or IPX protocol is supported. Logical Link Control (LLC) based protocols, such as SNA or NetBIOS, are also supported in this mode through token-ring to Ethernet conversion for LLC-based protocols.

- Mode 2 - When the 8229 is configured in mode 2, as a transparent MAC bridge, the 8229 transparently supports the transfer of LLC data. Protocols that are LLC-based and that may use the 8229 in this mode are the SNA and NetBIOS protocols.

Mode 1 is described in more detail as it supports the TCP/IP protocol. In mode 1 two different conversions are supported: token-ring to Ethernet and Ethernet to token-ring. Figure 5-14 shows a layered diagram of 8229 TCP/IP support.

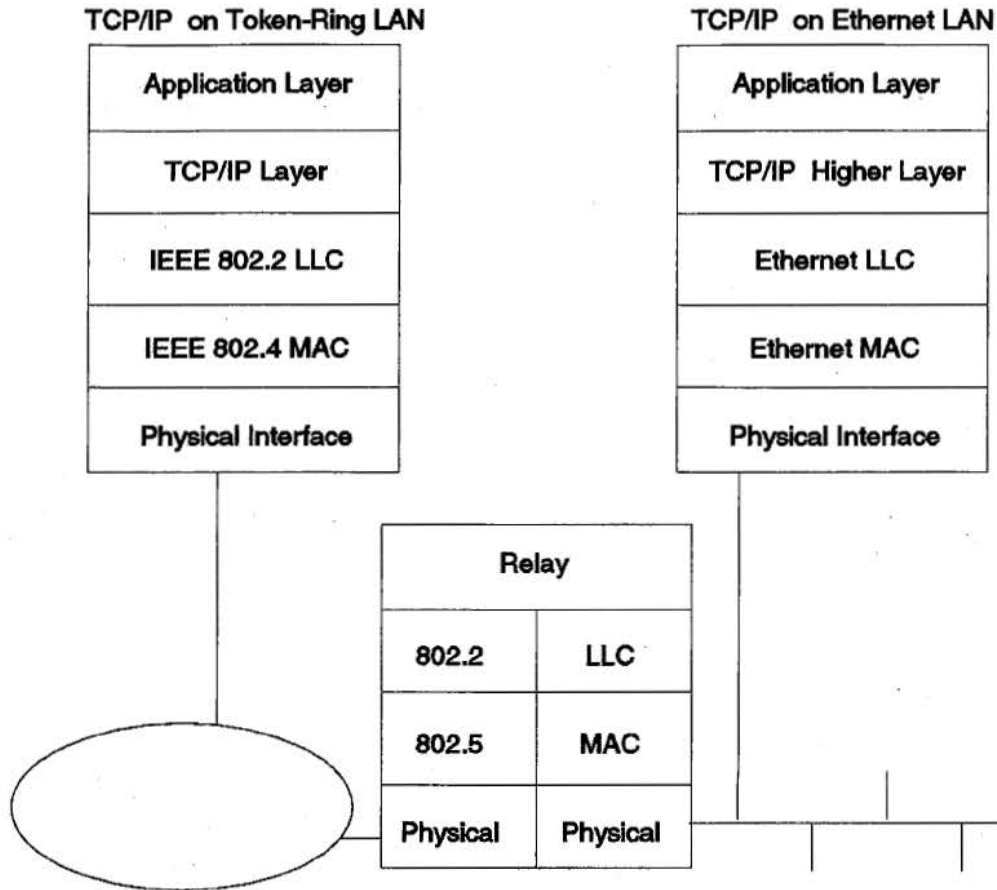
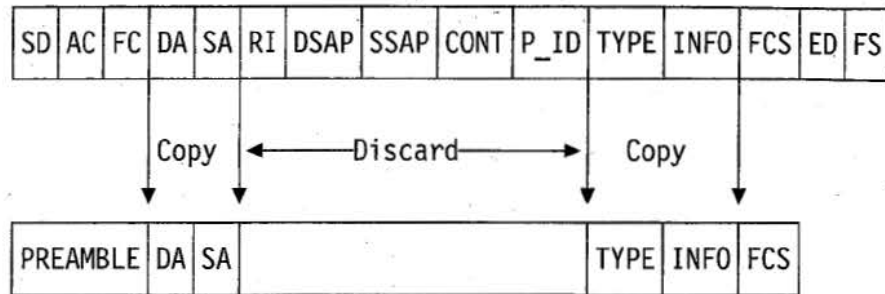

Figure 5-14. 8229 TCP/IP Support. Layered diagram.

Figure 5-15 on page 5-34 shows the conversion process.

Token-Ring to Ethernet Conversion



Ethernet to Token-Ring Conversion

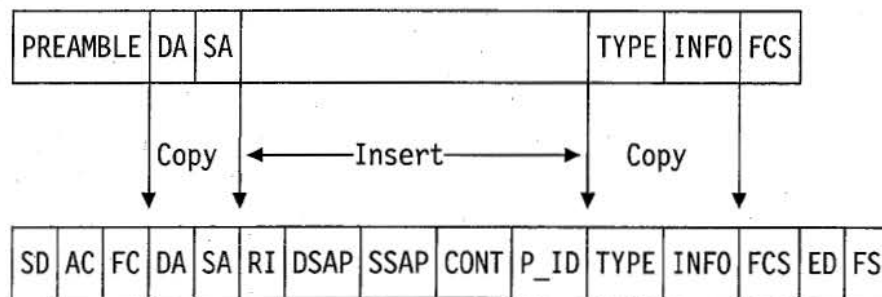

Figure 5-15. 8229 TCP/IP Support. Conversion process.

In the Ethernet to token-ring conversion the 8229 retrieves the source routing information associated with the token-ring destination address and inserts these fields and the fixed hex values AA AA 03 00 00 00 (SNAP header) representing the DSAP, SSAP, control and protocol ID fields into the frame.

The 8229 provides the following connections:

- Token-ring (all models)
 - DB-9 connector for STP cable (150 Ohms)
 - RJ-45 connector for UTP cable (100 Ohms)
- Ethernet/802.3 (Model 2)
 - AUI connector for 10Base-5 or 10Base-2 attachment
 - RJ-45 connector for 10Base-T attachment
- WAN (Model 3 only)
 - RS-232

- V.35
- X.21

5.18 IBM 8271 EtherStreamer Switch

LAN switches are a new family of network building blocks designed to increase the performance of departmental LANs and distributed workgroups and to do so in a cost effective manner. LAN segmentation, the separation of a population of LAN users into separate but interconnected LAN segments, is a popular technique for improving LAN performance by reducing contention. LAN switches offer a high performance, low cost alternative method for interconnecting LAN segments. The IBM 8271 creates multiple, high-speed, parallel paths among the connected Ethernet LAN segments and devices. Since each of these parallel paths supports the full 10 Mbps Ethernet bandwidth, total bandwidth of Ethernet networks segmented using the IBM 8271 can be expanded to up to 400% of previous levels.

The IBM 8271 supports full-duplex (bidirectional) communication with LAN stations equipped with Full-Duplex Ethernet adapters, such as the IBM EtherStreamer MC 32 Adapter. Full-duplex Ethernet connections can provide up to twice the bandwidth of standard half-duplex connections, that is, up to 20 Mbps on each of the switch ports (max. 8). A typical network would benefit from using the IBM 8271 by placing each server on a dedicated full-duplex segment and placing client workstations on shared segments using standard Ethernet concentrators, such as the IBM 8222 6-Port 10BaseT Workgroup Hub.

The IBM 8271 works like a normal Ethernet transparent multiport bridge and supports the spanning tree algorithm.

The SNMP agent has the following functionality:

- MIB II
- 8271 specific MIB
- SNMP GET/SET support
- Possible TRAPs:
 - Cold Start
 - Warm Start
 - Authentication Failure
 - New Root (related to spanning tree)
 - Topology Change (related to spanning tree)

TFTP/BOOTP is provided for microcode or configuration download.

For graphical management there is a Product Specific Module (PSM) available for use with the application *NetView for Windows* which greatly simplifies the management.

For further information please refer to *IBM 8271 Etherstreamer Switch Planning Guide*.

5.19 The IBM Hubs Family

Basically a hub is a wiring concentrator which connects the participating LAN workstations in a star-wired cabling system. Therefore a hub is mostly located in the wiring closet or near the workgroups. Today the term hub is used to describe multiprotocol devices offering sophisticated network management features and great flexibility for configuration.

One of the trends in networking is the move to centralize network functions in the wiring closet. This goes along with the trend toward collapsed backbones. A collapsed backbone uses the intelligent hub as the network backbone rather than using a segment of cable. Thus the backbone of the network is collapsed into the intelligent hub. This allows the network administrator to consolidate many network functions into a fault tolerant intelligent hub.

Hubs have been used in networks for wiring concentration for many years. Early hubs were passive devices that only provided for network connection such as the 8228. New hubs are becoming more sophisticated and they can do much more than act as wiring concentrators.

The following network functions can be consolidated in the intelligent hub:

- Port concentration
- Software bank and port switching - you can switch a user or a group of users from one network to another through software which saves time when making changes in the network
- Network management
- Terminal attachment - there are modules for attaching asynchronous terminals and 3270 terminals
- Bridging (SRB, TB, SRT, Translational Bridging)
- Switching - similar to bridging but faster

IBM offers a large variety of hub products to build a secure, reliable and manageable LAN. Hubs can be divided into two major groups: the first group, which supports only one specific LAN protocol token-ring or FDDI (workgroup hubs) for example, and the

second which supports multiple LAN protocols in a single box (intelligent hubs). In this section you get a brief description of the different available hubs and the major information from a TCP/IP point of view.

5.19.1 IBM 8230 Token-Ring Controlled Access Unit

The IBM 8230 is an intelligent token-ring network wiring concentrator, providing enhanced levels of control and reliability over passive token-ring network wiring concentrators, such as the IBM 8228.

The 8230 is a rack mountable device that:

- Supports ring operation at 4 and 16 Mbps
- Is able to function as a repeater in both ring directions (on main and backup path)
- Has pluggable ring-in and ring-out modules to support copper and fiber cable
- Has token-ring MAC appearances on both the main and backup ring path
- May have its microcode loaded from the IBM LAN Network Manager, or from a diagnostic utility, which is provided
- The IBM 8230 supports the IBM LAN Network Manager over CMOL by:
 - Maintaining the IBM LAN Network Manager's configuration table
 - Providing access control by reporting station insertions
 - Asset control in conjunction with IBM LAN Network Manager
- With the new Models 003 and 013 you have the ability to select either the CMOL or the SNMP management option with a switch on the front panel. There is a Product Specific Module (PSM) provided in order to manage this device graphically from NetView for Windows.
- The SNMP agent supports the following functions:
 - MIB II
 - Enterprise-specific MIB
 - Trap sending
 - GET/SET ability to enable/disable ports etc.

All SNMP setup is done via the out-of-band management port (RS-232).

The microcode update is done over TFTP.

The CMOL management provides the same functionality.

For further information please refer to *IBM 8230 Model 3 Planning Guide*.

5.19.2 IBM 8222 Workgroup Hub

The IBM 8222 offers low-cost attachment for six 10Base-T nodes and has no in- or out-of-band network management. One of the six ports can be used to cascade to another 10Base-T concentrator when expansion is needed. Its suitable environment could be in small offices, using either permanently installed UTP or short lengths of UTP between devices that are in close proximity to one another. However, the modular expandability of Ethernet and relatively easy connection to the earlier bus topologies allow the IBM 8222 to be used as part of larger, even establishment-wide, LANs.

For further information please refer to *IBM 6-Port 10Base-T Workgroup Hub Installation & Planning Guide*.

5.19.3 IBM 8224 Ethernet Stackable Hub

The 8224 is IBM's newest Ethernet/802.3 hub. It provides low cost connectivity for 10Base-T networks. It can be managed through SNMP and it can connect to existing 10Base-5, 10Base-2, 10Base-T, and fiber networks.

The 8224 is a stackable, SNMP manageable Ethernet hub for 10Base-T networks. The following is a list of 8224 features:

- 16 10Base-T ports
- Up to 10 8224s in a stack
- Model 2 is SNMP manageable

Supported are RFC 1213 MIB II, RFC 1516 Hub Repeater MIB for 802.3 and Novell Repeater MIB. The SNMP agent uses either IP or IPX as a networking protocol. Therefore the 8224 can be managed with an SNMP manager or Novell's NetWare Management Station. There is a Product Specific Module (PSM) available to manage this hub graphically from the IBM NetView for Windows application.

- Up to 9 8224 Model 1s can be managed by a Model 2
- Optional media expansion port to attach to 10Base-2, 10Base-5, fiber
- A stack of 8224s can be segmented into separate Ethernet segments

For further information please refer to *IBM 8224 Ethernet Stackable Hub Installation and User's Guide*.

5.19.4 IBM 8244 FDDI Workgroup Concentrator

The IBM 8244 Fiber Distributed Data Interface (FDDI) Workgroup Concentrator is the primary attachment to the FDDI dual-ring for attaching workstations to the backbone. The 8244 FDDI concentrator allows attaching up to 12 devices to a 100 Mbps network. These devices may be connected via:

- Multimode optical fiber, or
- IBM Cabling System's shielded twisted pair (STP) copper cable, or
- Unshielded twisted pair (UTP-5) copper cable

The 8244 can provide connection for FDDI devices that are based on the ANSI and ISO standards. The 8244 will operate with management entities that support the ANSI Station Management (SMT) 7.3 frame-based protocols.

Concentrator management is made possible via the imbedded FDDI SNMP agent. This agent will maintain the concentrator's FDDI MIB for SMT 7.3 (RFC 1512) and MIB II (RFC 1213) parameters for use by NetView for AIX or any original equipment manufacturer (OEM) SNMP-based network management system.

Network management is further enhanced by use of the complementary FDDI SNMP Proxy Agent on the OS/2 platform. This agent will convert SMT to SNMP protocols for use by NetView for AIX or any OEM SNMP-based network management system.

For further information please refer to *IBM 8244 FDDI Workgroup Concentrator: User's Guide*.

5.19.5 IBM 8250 Multiprotocol Intelligent Hub

The IBM 8250 Multiprotocol Intelligent Hub is a family of products designed to provide the platform to build LANs meeting the requirements of customers using various types of cabling systems (such as STP, UTP, fiber and coax) and different types of LANs (such as token-ring, Ethernet, and FDDI).

The 8250 family consists of four models of rack-mountable chassis, each offering an advanced backplane architecture, which allows the concurrent operation of several LANs using various LAN protocols. A range of media and management modules are also provided to allow the design of networks addressing the individual needs of each organization.

8250 modules can be added, removed or reconfigured while the 8250 is in operation. This allows changes to the configuration of the network without affecting the operation of the other users on the network.

For management purposes you need at least one management module per hub. This module can be one of the available management modules, a basic token-ring management module for example. Each of these modules includes a media access adapter, depending on the type of module, for in-band management and a RS-232 interface for out-of-band management. The module also includes the SNMP agent function with MIB II and a specific 8250 MIB and a TELNET server for remote configuration. The management module has access to all other modules residing in the

same hub via the management bus on the backplane. This gives you the ability to change the port assignments for example of a token-ring media module from an Ethernet management module without the need to buy a protocol specific management module for each supported protocol in the hub. Of course you won't get any media specific statistics or failures from another segment or LAN type.

The microcode update can be done by TFTP.

Management can be simplified by using the graphical application *IBM Intelligent Hub Manager for AIX*.

The newest 8250 MIB is available from the anonymous FTP server:
<ftp://venera.isi.edu/mib> on the Internet.

For further information please refer to *IBM 8250 Multiprotocol Intelligent Hub and IBM 8260 Multiprotocol Intelligent Switching Hub Planning and Site Preparation Guide*.

5.19.6 IBM 8260 Multiprotocol Intelligent Hub

The 8260 is IBM's newest intelligent hub. It is a hub platform for enterprise networking with an option of ATM for future growth. It can use existing 8250 modules so customers who have invested in 8250s can move to the 8260 without discarding their modules.

It can be used as a data center hub for consolidation of enterprise network functions. It also can be used as a wiring closet hub for port concentration and management.

It has all the features of the 8250 and the following new features:

- Increased LAN capacity
- Power supply load sharing for increased fault tolerance
- Distributed management architecture
- ATM upgrade option
- ATM media modules

The management of the 8260 hub is similar to the 8250 but more flexible. You can manage multiple LAN segments concurrently with only one management module because of the distributed architecture. The SNMP agent with the MIB II, the 8260 specific MIB, the TELNET server and all the IP functionality resides in the Distributed Management Module (DMM). The media access is provided by Media Access Cards (MAC) which can reside either as daughter cards directly on the media module or on the DMM carrier module. With this architecture you can "watch" up to 6 segments with only one DMM card. This saves space for other media modules and increases the maximum port density.

Management can be simplified by using the graphical application *IBM Intelligent Hub Manager for AIX*.

ATM management

The 8260 Switch/Control Point Module implements an SNMP ATM agent that includes objects defined by the standards bodies, as well as IBM specific extensions for superior manageability of ATM networks from the network management station

This SNMP agent features the following functions:

- Full SNMP support (get, getnext, set and traps) allowing complete control and monitoring through SNMP commands
- Support of IP over ATM (RFC 1577) for node management and services. Network management stations can therefore contact the switch/control point module agent either through direct connection to the ATM network using IP over ATM, or connected to a traditional LAN that is routed to the ATM subnetwork
- MIB 2 support
- Full ILMI¹ (ATM Forum V3.0) support (at UNI² and from network management station)
- IETF AToMIB, allowing the network administrator to display the status and configuration of 8260 ATM interfaces, including active VPCs and VCCs. Statistics on ATM interfaces are also collected via this MIB
- MIB support for topology and route computation management, allowing the display from the central management station of the topology of the 8260 network and the set of attached ATM stations
- IBM-specific extensions

With the graphical application *IBM ATM Campus Manager for AIX* the management is greatly simplified.

The newest 8260 MIB is available from the anonymous FTP server:
<ftp://venera.isi.edu/mib> on the Internet.

For further information please refer to *IBM 8250 Multiprotocol Intelligent Hub and IBM 8260 Multiprotocol Intelligent Switching Hub Planning and Site Preparation Guide*.

¹ ILMI (Interim Local Management Interface) defined by ATM Forum to provide standardized management information and formats until the official ITU-T (former CCITT) standard is produced.

² UNI(User Network Interface)

5.20 Connectivity Summary

The following table shows operating system support for selected connectivity options.

	S/370			PS/2		RISC/6000	AS/400
	MVS	VM	AIX	DOS	OS/2	AIX	OS/400
Token-Ring	x	x	x	x	x	x	x
Ethernet V2	x	x	x	x	x	x	x
802.3	x	x	x	x	x	x	x
FDDI	x	x	x	x	x	x	x
PC Network	x	x		x	x		
X.25	x	x	PS/2		x	x	x
SLIP				x	x	x	
SNALINK LU0 LU6.2	x x	x x			x		
HYPERchannel	x	x	x				
HIPPI	x		x				
CTC	x	x					
CETI	x						
RS/6000 PCA	x	x	x			x	
RS/6000 ECUA	x	x	x			x	
3172 Offload	x	x					
3745 ESS	x	x					
3174 Telnetd	x	x	x		x	x	x

SOD = Statement of Direction
 PCA = Parallel Channel Attachment
 ECUA = ESCON Control Unit Adapter
 3745 ESS = 3745 Ethernet SubSystem support for IP and ARP routing
 3174 Telnetd = Telnet Server support for the 3174 Telnet Client function

Figure 5-16. Connectivity Summary