



US007673072B2

(12) **United States Patent**
Boucher et al.

(10) **Patent No.:** **US 7,673,072 B2**

(45) **Date of Patent:** **Mar. 2, 2010**

(54) **FAST-PATH APPARATUS FOR TRANSMITTING DATA CORRESPONDING TO A TCP CONNECTION**

(75) Inventors: **Laurence B. Boucher**, Saratoga, CA (US); **Stephen E. J. Blightman**, San Jose, CA (US); **Peter K. Craft**, San Francisco, CA (US); **David A. Higgen**, Saratoga, CA (US); **Clive M. Philbrick**, San Jose, CA (US); **Daryl D. Starr**, Milpitas, CA (US)

(73) Assignee: **Alacritech, Inc.**, San Jose, CA (US)

(*) Notice: Subject to any disclaimer, the term of this patent is extended or adjusted under 35 U.S.C. 154(b) by 435 days.

(21) Appl. No.: **11/821,820**

(22) Filed: **Jun. 25, 2007**

(65) **Prior Publication Data**

US 2008/0126553 A1 May 29, 2008

Related U.S. Application Data

(63) Continuation of application No. 10/260,112, filed on Sep. 27, 2002, now Pat. No. 7,237,036, which is a continuation of application No. 10/092,967, filed on Mar. 6, 2002, now Pat. No. 6,591,302, which is a continuation-in-part of application No. 10/023,240, filed on Dec. 17, 2001, now Pat. No. 6,965,941, which is a continuation-in-part of application No. 09/464,283, filed on Dec. 15, 1999, now Pat. No. 6,427,173, which is a continuation-in-part of application No. 09/439,603, filed on Nov. 12, 1999, now Pat. No. 6,247,060, which is a continuation-in-part of application No. 09/067,544, filed on Apr. 27, 1998, now Pat. No. 6,226,680, said application No. 10/260,112 is a continuation-in-part of application No. 09/384,792, filed on Aug. 27, 1999, now Pat. No. 6,434,620, which is a continuation-in-part of application No. 09/141,713, filed on Aug. 28, 1998, now Pat. No. 6,389,479,

said application No. 10/260,112 is a continuation-in-part of application No. 09/970,124, filed on Oct. 2, 2001, now Pat. No. 7,124,205, and a continuation-in-part of application No. 09/855,979, filed on May 14, 2001, now Pat. No. 7,133,940, and a continuation-in-part of application No. 09/802,550, filed on Mar. 9, 2001, now Pat. No. 6,658,480, and a continuation-in-part of application No. 09/802,426, filed on Mar. 9, 2001, now Pat. No. 7,042,898, and a continuation-in-part of application No. 09/802,551, filed on Mar. 9, 2001, now Pat. No. 7,076,568, and a continuation-in-part of application No. 09/801,488, filed on Mar. 7, 2001, now Pat. No. 6,687,758, and a continuation-in-part of application No. 09/789,366, filed on Feb. 20, 2001, now Pat. No. 6,757,746, and a continuation-in-part of application No. 09/675,700, filed on Sep. 29, 2000, and a continuation-in-part of application No. 09/675,484, filed on Sep. 29, 2000, now Pat. No. 6,807,581, and a continuation-in-part of application No. 09/514,425, filed on Feb. 28, 2000, now Pat. No. 6,427,171, and a continuation-in-part of application No. 09/416,925, filed on Oct. 13, 1999, now Pat. No. 6,470,415.

(60) Provisional application No. 60/061,809, filed on Oct. 14, 1997, provisional application No. 60/098,296, filed on Aug. 27, 1998.

(51) **Int. Cl.**
G06F 15/16 (2006.01)

(52) **U.S. Cl.** **709/245**; 709/230; 709/233; 709/234; 709/232; 709/239; 370/235; 370/468; 370/237; 370/230; 370/233

(58) **Field of Classification Search** 709/245, 709/230-234, 239, 250; 370/235, 468, 237, 370/230, 233, 234
See application file for complete search history.

(56) **References Cited**

U.S. PATENT DOCUMENTS

4,366,538 A	12/1982	Johnson et al.	364/200
4,485,455 A	11/1984	Boone et al.	364/900
4,485,460 A	11/1984	Stambaugh	365/203
4,589,063 A	5/1986	Shah et al.	710/8

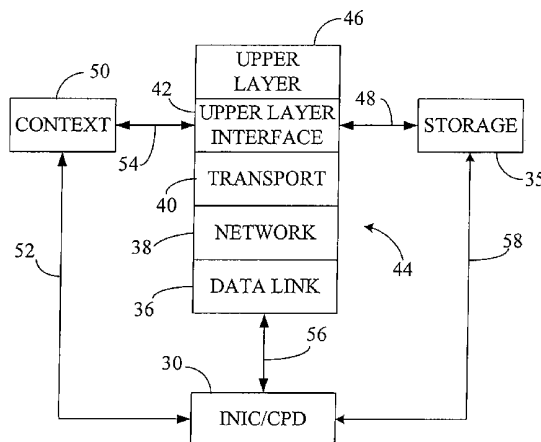

4,700,185	A	10/1987	Balph et al.	340/825.5	5,931,918	A	8/1999	Row et al.	709/300
4,991,133	A	2/1991	Davis et al.	364/900	5,935,205	A	8/1999	Murayama et al.	709/216
5,056,058	A	10/1991	Hirata et al.	709/230	5,937,169	A	8/1999	Connery et al.	395/200.8
5,058,110	A	10/1991	Beach et al.	370/85.6	5,941,969	A	8/1999	Ram et al.	710/128
5,097,442	A	3/1992	Ward et al.	365/78	5,941,972	A	8/1999	Hoese et al.	710/129
5,163,131	A	11/1992	Row et al.	395/200	5,950,203	A	9/1999	Stakuis et al.	707/10
5,212,778	A	5/1993	Dally et al.	395/400	5,987,022	A	11/1999	Geiger et al.	370/349
5,280,477	A	1/1994	Trapp	370/85.1	5,991,299	A	11/1999	Radogna et al.	370/392
5,289,580	A	2/1994	Latif et al.	395/275	5,996,013	A	11/1999	Delp et al.	709/226
5,303,344	A	4/1994	Yokoyama et al.	395/200	5,996,024	A	11/1999	Blumenau	709/301
5,412,782	A	5/1995	Hausman et al.	395/250	6,005,849	A	12/1999	Roach et al.	370/276
5,418,912	A	5/1995	Christenson	395/200	6,009,478	A	12/1999	Panner et al.	710/5
5,448,566	A	9/1995	Richter et al.	370/94.1	6,016,513	A	1/2000	Lowe	709/250
5,485,579	A	1/1996	Hitz et al.	395/200.12	6,021,446	A	2/2000	Gentry et al.	709/303
5,506,966	A	4/1996	Ban	395/250	6,021,507	A	2/2000	Chen	714/2
5,511,169	A	4/1996	Suda	395/280	6,026,452	A	2/2000	Pitts	710/56
5,517,668	A	5/1996	Szwerinski et al.	395/800	6,034,963	A	3/2000	Minami et al.	370/401
5,524,250	A	6/1996	Chesson et al.	395/775	6,038,562	A	3/2000	Anjur et al.	707/10
5,535,375	A	7/1996	Eshel et al.	391/500	6,041,058	A	3/2000	Flanders et al.	370/401
5,548,730	A	8/1996	Young et al.	395/280	6,041,381	A	3/2000	Hoese	710/129
5,566,170	A	10/1996	Bakke et al.	370/60	6,044,438	A	3/2000	Olnowich	711/130
5,574,919	A	11/1996	Netravali et al.	395/561	6,047,323	A	4/2000	Krause	709/227
5,588,121	A	12/1996	Reddin et al.	395/200.15	6,047,356	A	4/2000	Anderson et al.	711/129
5,590,328	A	12/1996	Seno et al.	395/675	6,049,528	A	4/2000	Hendel et al.	370/235
5,592,622	A	1/1997	Isfeld et al.	395/200.02	6,057,863	A	5/2000	Olarig	345/520
5,598,410	A	1/1997	Stone	370/469	6,061,368	A	5/2000	Hitzelberger	370/537
5,619,650	A	4/1997	Bach et al.	395/200.01	6,065,096	A	5/2000	Day et al.	711/114
5,629,933	A	5/1997	Delp et al.	370/411	6,067,569	A	5/2000	Khaki et al.	709/224
5,633,780	A	5/1997	Cronin et al.	361/220	6,070,200	A	5/2000	Gates et al.	710/20
5,634,099	A	5/1997	Andrews et al.	395/200.07	6,078,733	A	6/2000	Osborne	395/200.8
5,634,127	A	5/1997	Cloud et al.	395/680	6,097,734	A	8/2000	Gotesman et al.	370/474
5,642,482	A	6/1997	Pardillos	395/200.2	6,101,555	A	8/2000	Goshey et al.	709/321
5,664,114	A	9/1997	Krech, Jr. et al.	395/200.64	6,111,673	A	8/2000	Chang et al.	359/123
5,671,355	A	9/1997	Collins	395/200.2	6,115,615	A	9/2000	Ota et al.	455/553
5,678,060	A	10/1997	Yokoyama et al.	709/212	6,122,670	A	9/2000	Bennett et al.	709/236
5,682,534	A	10/1997	Kapoor et al.	395/684	6,141,701	A	10/2000	Whitney	710/5
5,692,130	A	11/1997	Shobu et al.	395/200.12	6,141,705	A	10/2000	Anand et al.	710/15
5,699,317	A	12/1997	Sartore et al.	395/230.06	6,145,017	A	11/2000	Ghaffari	710/5
5,699,350	A	12/1997	Kraslavsky	370/254	6,157,944	A	12/2000	Pedersen	
5,701,434	A	12/1997	Nakagawa	395/484	6,157,955	A	12/2000	Narad et al.	709/228
5,701,516	A	12/1997	Cheng et al.	395/842	6,172,980	B1	1/2001	Flanders et al.	370/401
5,727,142	A	3/1998	Chen	395/181	6,173,333	B1	1/2001	Jolitz et al.	
5,742,765	A	4/1998	Wong et al.	395/200	6,181,705	B1	1/2001	Branstad et al.	370/392
5,749,095	A	5/1998	Hagersten	711/141	6,202,105	B1	3/2001	Gates et al.	710/20
5,751,715	A	5/1998	Chan et al.	370/455	6,223,242	B1	4/2001	Sheafor et al.	710/132
5,752,078	A	5/1998	Delp et al.	395/827	6,226,680	B1	5/2001	Boucher et al.	709/230
5,758,084	A	5/1998	Silverstein et al.	395/200.58	6,246,683	B1	6/2001	Connery et al.	370/392
5,758,089	A	5/1998	Gentry et al.	395/200.64	6,247,060	B1	6/2001	Boucher et al.	709/238
5,758,186	A	5/1998	Hamilton et al.	395/831	6,279,051	B1	8/2001	Gates et al.	710/20
5,758,194	A	5/1998	Kuzma	395/886	6,289,023	B1	9/2001	Dowling et al.	370/419
5,768,618	A	6/1998	Erickson et al.	395/829	6,298,403	B1	10/2001	Suri et al.	710/100
5,771,349	A	6/1998	Picazo, Jr. et al.	395/188.01	6,324,649	B1	11/2001	Eyres et al.	713/202
5,774,660	A	6/1998	Brendel et al.	395/200.31	6,334,153	B2	12/2001	Boucher et al.	709/230
5,778,013	A	7/1998	Jedwab	714/807	6,343,360	B1	1/2002	Feinleib	713/1
5,778,419	A	7/1998	Hansen et al.	711/112	6,345,301	B1	2/2002	Burns et al.	709/230
5,790,804	A	8/1998	Osborne	709/245	6,345,302	B1	2/2002	Bennett et al.	709/236
5,794,061	A	8/1998	Hansen et al.	395/800.01	6,356,951	B1	3/2002	Gentry et al.	709/250
5,802,258	A	9/1998	Chen	395/182.08	6,370,599	B1	4/2002	Anand et al.	710/15
5,802,580	A	9/1998	McAlpine	711/149	6,385,647	B1	5/2002	Willis et al.	709/217
5,809,328	A	9/1998	Nogales et al.	395/825	6,389,468	B1	5/2002	Muller et al.	709/226
5,809,527	A	9/1998	Cooper et al.	711/133	6,389,479	B1	5/2002	Boucher	709/243
5,812,775	A	9/1998	Van Seeters et al.	395/200.43	6,393,487	B2	5/2002	Boucher et al.	709/238
5,815,646	A	9/1998	Purcell et al.	395/163	6,421,742	B1	7/2002	Tillier	710/1
5,828,835	A	10/1998	Isfeld et al.	395/200.3	6,421,753	B1	7/2002	Hoese et al.	710/129
5,848,293	A	12/1998	Gentry et al.	395/825	6,427,169	B1	7/2002	Elzur	709/224
5,852,721	A	* 12/1998	Dillon et al.	709/217	6,427,171	B1	7/2002	Craft et al.	709/230
5,872,919	A	2/1999	Wakeland et al.	395/200	6,427,173	B1	7/2002	Boucher et al.	709/238
5,878,225	A	3/1999	Bilansky et al.	395/200.57	6,434,620	B1	8/2002	Boucher et al.	709/230
5,892,903	A	4/1999	Klaus	395/187.01	6,434,651	B1	8/2002	Gentry, Jr.	710/260
5,898,713	A	4/1999	Melzer et al.	371/53	6,449,656	B1	9/2002	Elzur et al.	709/236
5,913,028	A	6/1999	Wang et al.	395/200.33	6,453,360	B1	9/2002	Muller et al.	709/250
5,920,566	A	7/1999	Hendel et al.	370/401	6,470,415	B1	10/2002	Starr et al.	711/104
5,930,830	A	7/1999	Mendelson et al.	711/171	6,473,425	B1	10/2002	Bellaton et al.	370/392

6,480,489	B1	11/2002	Muller et al.	370/389
6,487,202	B1	11/2002	Klausmeier et al.	370/395
6,487,654	B2	11/2002	Dowling	712/244
6,490,631	B1	12/2002	Teich et al.	709/250
6,502,144	B1	12/2002	Accarie	710/8
6,523,119	B2	2/2003	Pavlin et al.	713/192
6,526,446	B1	2/2003	Yang et al.	
6,570,884	B1	5/2003	Connery et al.	370/419
6,591,302	B2	7/2003	Boucher et al.	709/230
6,591,310	B1	7/2003	Johnson	710/3
6,648,611	B2	11/2003	Morse et al.	417/310
6,650,640	B1	11/2003	Muller et al.	370/392
6,657,757	B1	12/2003	Chang et al.	359/124
6,658,480	B2	12/2003	Boucher et al.	709/239
6,678,283	B1	1/2004	Teplitsky	370/463
6,681,364	B1	1/2004	Calvignac et al.	714/776
6,687,758	B2	2/2004	Craft et al.	709/250
6,697,868	B2	2/2004	Craft et al.	709/230
6,751,665	B2	6/2004	Philbrick et al.	709/224
6,757,746	B2	6/2004	Boucher et al.	709/250
6,765,901	B1	7/2004	Johnson et al.	370/352
6,807,581	B1	10/2004	Starr et al.	709/250
6,842,896	B1	1/2005	Redding et al.	717/172
6,912,522	B2	6/2005	Edgar	707/2
6,938,092	B2	8/2005	Burns	709/230
6,941,386	B2	9/2005	Craft et al.	709/250
6,965,941	B2	11/2005	Boucher et al.	709/230
6,996,070	B2	2/2006	Starr et al.	370/252
7,042,898	B2	5/2006	Blightman et al.	370/463
7,076,568	B2	7/2006	Philbrick et al.	709/250
7,089,326	B2	8/2006	Boucher et al.	709/242
7,093,099	B2	8/2006	Bodas et al.	711/206
7,124,205	B2	10/2006	Craft et al.	709/250
7,133,940	B2	11/2006	Blightman et al.	710/22
7,167,926	B1	1/2007	Boucher et al.	709/250
7,167,927	B2	1/2007	Philbrick et al.	709/250
7,174,393	B2	2/2007	Boucher et al.	709/250
7,185,266	B2	2/2007	Blightman et al.	714/776
7,191,241	B2	3/2007	Boucher et al.	709/230
7,191,318	B2	3/2007	Tripathy et al.	712/225
7,237,036	B2	6/2007	Boucher et al.	709/245
7,254,696	B2	8/2007	Mittal et al.	712/210
7,284,070	B2	10/2007	Boucher et al.	709/250
2001/0004354	A	1/2001	Jolitz	370/328
2001/0025315	A	1/2001	Jolitz	709/231
2001/0013059	A1	8/2001	Dawson et al.	709/217
2001/0014892	A1	8/2001	Gaither et al.	707/200
2001/0014954	A1	8/2001	Purcell et al.	714/4
2001/0048681	A1	12/2001	Bilic et al.	370/389
2001/0053148	A1	12/2001	Bilic et al.	370/389
2002/0073223	A1	6/2002	Darnell et al.	709/232
2002/0112175	A1	8/2002	Makofka et al.	713/200
2003/0066011	A1	4/2003	Oren	714/758
2003/0110344	A1	6/2003	Szczepanek et al.	711/100
2003/0165160	A1	9/2003	Minami et al.	370/466
2004/0054814	A1	3/2004	McDaniel	
2004/0059926	A1	3/2004	Angelo et al.	713/168
2004/0153578	A1	8/2004	Elzur	
2004/0213290	A1	10/2004	Johnson et al.	370/469
2004/0246974	A1	12/2004	Gyugyi et al.	370/395.31

FOREIGN PATENT DOCUMENTS

WO	WO 98/19412	5/1998
WO	WO 98/50852	11/1998
WO	WO 99/04343	1/1999
WO	WO 99/65219	12/1999
WO	WO 00/13091	3/2000
WO	WO 01/04770	1/2001
WO	WO 01/05107	1/2001
WO	WO 01/05116	1/2001
WO	WO 01/05123	1/2001
WO	WO 01/40960	6/2001

WO	WO 01/59966	8/2001
WO	WO 01/86430	11/2001

OTHER PUBLICATIONS

Internet pages entitled "Hardware Assisted Protocol Processing", (which Eugene Feinber is working on), 1 page, printed Nov. 25, 1998.

Zilog product Brief entitled "Z85C30 CMOS SCC Serial Communication Controller", Zilog Inc., 3 pages, 1997.

Internet pages of Xpoint Technologies, Inc. entitled "Smart LAN Work Requests", 5 pages, printed Dec. 19, 1997.

Internet pages entitled: Asante and 100BASE-T Fast Ethernet. 7 pages, printed May 27, 1997.

Internet pages entitled: A Guide to the Paragon XP/S-A7 Supercomputer at Indiana University. 13 pages, printed Dec. 21, 1998.

Richard Stevens, "TCP/IP Illustrated, vol. 1, The Protocols", pp. 325-326 (1994).

Internet pages entitled: Northridge/Southbridge vs. Intel Hub Architecture, 4 pages, printed Feb. 19, 2001.

Gigabit Ethernet Technical Brief, Achieving End-to-End Performance. Alteon Networks, Inc., First Edition, Sep. 1996, 15 pages.

Internet pages directed to Technical Brief on Alteon Ethernet Gigabit NIC technology, www.alteon.com, 14 pages, printed Mar. 15, 1997.

Via Technologies, Inc. article entitled "VT8501 Apollo MVP4", pp. i-iv, 1-11, cover and copyright page, revision 1.3, Feb. 1, 2000.

iReady News Archives article entitled "iReady Rounding Out Management Team with Two Key Executives", <http://www.ireadyco.com/archives/keyexec.html>, 2 pages, printed Nov. 28, 1998.

"Toshiba Delivers First Chips to Make Consumer Devices Internet-Ready Based On iReady's Design," Press Release Oct. 1998, 3 pages, printed Nov. 28, 1998.

Internet pages from iReady Products, web site <http://www.ireadyco.com/products.html>, 2 pages, downloaded Nov. 25, 1998.

iReady News Archives, Toshiba, iReady shipping Internet chip, 1 page, printed Nov. 25, 1998.

Interprophet article entitled "Technology", <http://www.interprophet.com/technology.html>, 17 pages, printed Mar. 1, 2000.

iReady Corporation, article entitled "The 1-1000 Internet Tuner", 2 pages, date unknown.

iReady article entitled "About Us Introduction", Internet pages from <http://www.ireadyco.com/about.html>, 3 pages, printed Nov. 25, 1998.

iReady News Archive article entitled "Revolutionary Approach to Consumer Electronics Internet Connectivity Funded", San Jose, CA, Nov. 20, 1997. 2 pages, printed Nov. 2, 1998.

iReady News Archive article entitled "Seiko Instruments Inc. (SII) Introduces World's First Internet-Ready Intelligent LCD Modules Based on iReady Technology," Santa Clara, CA and Chiba, Japan, Oct. 26, 1998. 2 pages, printed Nov. 2, 1998.

NEWSwatch article entitled "iReady internet Tuner to Web Enable Devices", Tuesday, Nov. 5, 1996, printed Nov. 2, 1998, 2 pages.

EETimes article entitled "Tuner for Toshiba, Toshiba Taps iReady for Internet Tuner", by David Lammers, 2 pages, printed Nov. 2, 1998.

"Comparison of Novell Netware and TCP/IP Protocol Architectures", by J.S. Carbone, 19 pages, printed Apr. 10, 1998.

Adaptec article entitled "AEA-7110C-a DuraSAN product", 11 pages, printed Oct. 1, 2001.

iSCSI HBA article entitled "iSCSI and 2Gigabit fibre Channel Host Bus Adapters from Emulex, QLogic, Adaptec, JN1", 8 pages, printed Oct. 1, 2001.

iSCSI HBA article entitled "FCE-3210/6410 32 and 64-bit PCI-to-Fibre Channel HBA", 6 pages, printed Oct. 1, 2001.

ISCSI.com article entitled "iSCSI Storage", 2 pages, printed Oct. 1, 2001.

"Two-Way TCP Traffic Over Rate Controlled Channels: Effects and Analysis", by Kalamoukas et al., IEEE Transactions on Networking, vol. 6, No. 6, Dec. 1998, 17 pages.

iReady News article entitled "Toshiba Delivers First Chips to Make Consumer Devices Internet-Ready Based on iReady Design", Santa Clara, CA, and Tokyo, Japan, Oct. 14, 1998, printed Nov. 2, 1998, 3 pages.

- Internet pages of InterProphet entitled "Frequently Asked Questions", by Lynne Jolitz, printed Jun. 14, 2000, 4 pages.
- "File System Design For An NFS File Server Appliance", Article by D. Hitz, et al., 13 pages.
- Adaptec Press Release article entitled "Adaptec Announces EtherStorage Technology", 2 pages, May 4, 2000, printed Jun. 14, 2000.
- Adaptec article entitled "EtherStorage Frequently Asked Questions", 5 pages, printed Jul. 19, 2000.
- Adaptec article entitled "EtherStorage White Paper", 7 pages, printed Jul. 19, 2000.
- CIBC World Markets article entitled "Computers; Storage", by J. Berlino et al., 9 pages, dated Aug. 7, 2000.
- Merrill Lynch article entitled "Storage Futures", by S. Milunovich, 22 pages, dated May 10, 2000.
- CBS Market Watch article entitled "Montreal Start-Up Battles Data Storage Bottleneck", by S. Taylor, dated Mar. 5, 2000, 2 pages, printed Mar. 7, 2000.
- Internet-draft article entitled "SCSI/TCP (SCSI over TCP)", by J. Satran et al., 38 pages, dated Feb. 2000, printed May 19, 2000.
- Internet pages entitled Technical White Paper-Xpoint's Disk to LAN Acceleration Solution for Windows NT Server, printed Jun. 5, 1997, 15 pages.
- Jato Technologies article entitled Network Accelerator Chip Architecture, twelve-slide presentation, printed Aug. 19, 1998, 13 pages.
- EETimes article entitled Enterprise System Uses Flexible Spec, dated Aug. 10, 1998, printed Nov. 25, 1998, 3 pages.
- Internet pages entitled "Smart Ethernet Network Interface Cards", which Berend Ozceri is developing, printed Nov. 25, 1998, 2 pages.
- Internet pages of Xahti corporation entitled "GigaPower Protocol Processor Product Review," printed Nov. 25, 1999, 4 pages.
- U.S. Appl. No. 60/283,896, Titled: CRC Calculations for Out of Order PUDs, filed Apr. 12, 2003, Inventor: Amit Oren, Assignee: Siliquent Technologies Ltd.
- Internet pages entitled "DART: Fast Application Level Networking via Data-Copy Avoidance," by Robert J. Walsh, printed Jun. 3, 1999, 25 pages.
- Andrew S. Tanenbaum, Computer Networks, Third Edition, 1996, ISBN 0-13-349945-6.
- Article from Rice University entitled "LRP: A New Network Subsystem Architecture for Server Systems", by Peter Druschel and Gaurav Banga, 14 pages.
- Internet RFC/STD/FYI/BCP Archives article with heading "RFC2140" entitled "TCP Control Block Interdependence", web address <http://www.faqs.org/rfcs/rfc2140.html>, 9 pages, printed Sep. 20, 2002.
- WindRiver article entitled "Tornado: For Intelligent Network Acceleration", copyright Wind River Systems, 2001, 2 pages.
- WindRiver White Paper entitled "Complete TCP/IP Offload for High-Speed Ethernet Networks", Copyright Wind River Systems, 2002, 7 pages.
- Intel article entitled "Solving Server Bottlenecks with Intel Server Adapters", Copyright Intel Corporation, 1999, 8 pages.
- Schwaderer et al., IEEE Computer Society Press publication entitled, "XTP in VLSI Protocol Decomposition for ASIC Implementation", from 15th Conference on Local Computer Networks, 5 pages, Sep. 30-Oct. 3, 1990.
- Beach, Bob, IEEE Computer Society Press publication entitled, "UltraNet: An Architecture for Gigabit Networking", from 15th Conference on Local Computer Networks, 18 pages, Sep. 30-Oct. 3, 1990.
- Chesson et al., IEEE Symposium Record entitled, "The Protocol Engine Chipset", from Hot Chips III, 16 pages, Aug. 26-27, 1991.
- Maclean et al., IEEE Global Telecommunications Conference, Globecom '91, presentation entitled, "An Outboard Processor for High Performance Implementation of Transport Layer Protocols", 7 pages, Dec. 2-5, 1991.
- Ross et al., IEEE article entitled "FX1000: A high performance single chip Gigabit Ethernet NIC", from Compcon '97 Proceedings, 7 pages, Feb. 23-26, 1997.
- Strayer et al., "Ch. 9: The Protocol Engine" from XTP: The Transfer Protocol, 12 pages, Jul. 1992.
- Publication entitled "Protocol Engine Handbook", 44 pages, Oct. 1990.
- Koufopavlou et al., IEEE Global Telecommunications Conference, Globecom '92, presentation entitled, "Parallel TCP for High Performance Communication Subsystems", 7 pages, Dec. 6-9, 1992.
- Lilienkamp et al., Publication entitled "Proposed Host-Front End Protocol", 56 pages, Dec. 1984.
- Thia et al. Publication entitled "High-Speed OSI Protocol Bypass Algorithm with Window Flow Control," Protocols for High Speed Networks, pp. 53-68, 1993.
- U.S. Appl. No. 60/053,240, Titled: TCP/IP Network Accelerator and Method of Use, filed Jul. 17, 1997, Inventor: William Jolitz et al.
- Thia et al. Publication entitled "A Reduced Operational Protocol Engine (ROPE) for a multiple-layer bypass architecture," Protocols for High Speed Networks, pp. 224-239, 1995.
- Form 10-K for Exelan, Inc., for the fiscal year ending Dec. 31, 1987 (10 pages).
- Form 10-K for Exelan, Inc., for the fiscal year ending Dec. 31, 1988 (10 pages).
- * cited by examiner
- Primary Examiner*—Jude J Jean Gilles
(74) *Attorney, Agent, or Firm*—Mark Lauer; Silicon Edge Law Group, LLP

(57)

ABSTRACT

A system for protocol processing in a computer network has an intelligent network interface card (INIC) or communication processing device (CPD) associated with a host computer. The INIC provides a fast-path that avoids protocol processing for most large multi-packet messages, greatly accelerating data communication. The INIC also assists the host for those message packets that are chosen for processing by host software layers. A communication control block for a message is defined that allows DMA controllers of the INIC to move data, free of headers, directly to or from a destination or source in the host. The context is stored in the INIC as a communication control block (CCB) that can be passed back to the host for message processing by the host. The INIC contains specialized hardware circuits that are much faster at their specific tasks than a general purpose CPU. A preferred embodiment includes a trio of pipelined processors with separate processors devoted to transmit, receive and management processing, with full duplex communication for four fast Ethernet nodes.

21 Claims, 89 Drawing Sheets

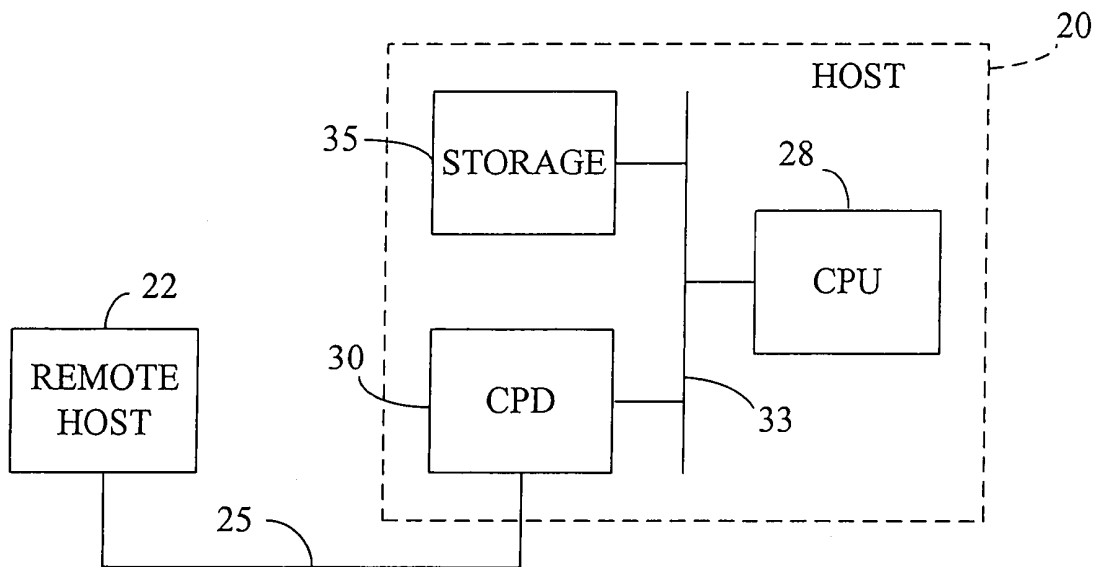

FIG. 1

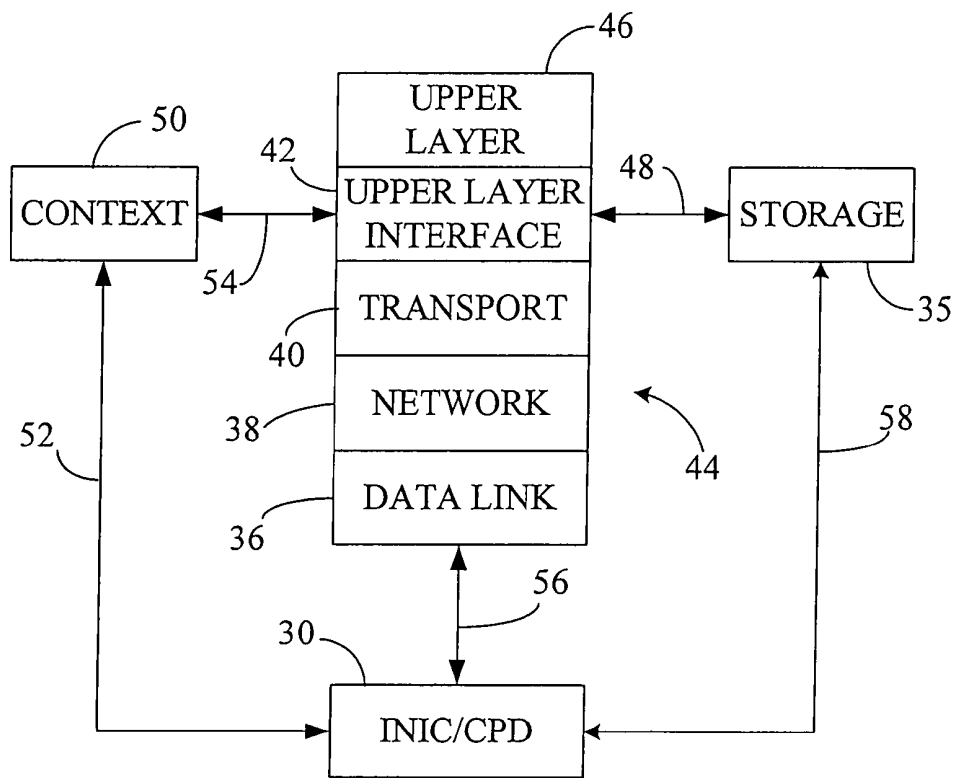

FIG. 2

Explore Litigation Insights

Docket Alarm provides insights to develop a more informed litigation strategy and the peace of mind of knowing you're on top of things.

Real-Time Litigation Alerts



Keep your litigation team up-to-date with **real-time alerts** and advanced team management tools built for the enterprise, all while greatly reducing PACER spend.

Our comprehensive service means we can handle Federal, State, and Administrative courts across the country.

Advanced Docket Research



With over 230 million records, Docket Alarm's cloud-native docket research platform finds what other services can't. Coverage includes Federal, State, plus PTAB, TTAB, ITC and NLRB decisions, all in one place.

Identify arguments that have been successful in the past with full text, pinpoint searching. Link to case law cited within any court document via Fastcase.

Analytics At Your Fingertips



Learn what happened the last time a particular judge, opposing counsel or company faced cases similar to yours.

Advanced out-of-the-box PTAB and TTAB analytics are always at your fingertips.

API

Docket Alarm offers a powerful API (application programming interface) to developers that want to integrate case filings into their apps.

LAW FIRMS

Build custom dashboards for your attorneys and clients with live data direct from the court.

Automate many repetitive legal tasks like conflict checks, document management, and marketing.

FINANCIAL INSTITUTIONS

Litigation and bankruptcy checks for companies and debtors.

E-DISCOVERY AND LEGAL VENDORS

Sync your system to PACER to automate legal marketing.