

# Demultiplexing on the ATM Adapter: Experiments with Internet Protocols in User Space \*

Ernst W. Biersack, Erich Rüsche

B.P. 193

06904 Sophia Antipolis, Cedex

FRANCE

e-mail: erbi@eurecom.fr, rue@zh.xmit.ch

## Abstract

We took a public domain implementation of the TCP/IP protocol stack and ported into user space. The user space implementation was then optimized by a one-to-one mapping of transport connections onto ATM connections and a packet filter. We describe the user space implementation and compare its latency and throughput performance with the existing kernel implementation.

---

\*Published in: Journal on High Speed Networks, Vol. 5, No. 2, May 1996

# 1 Introduction

Processing of protocols has been perceived as a major bottleneck in the communication performance. To get around this bottleneck various approaches have been examined. The offloading of entire protocols or protocol functions onto adapters or communication subsystems was not successful because the I/O interface of the workstations limited the performance gained by the subsystem. Experiments with newer, so called light-weight protocols showed that improved protocols could add functionality but their performance did not give sufficient evidence to replace traditional protocols such as TCP/IP. However, in the implementation of protocols still a considerable gain can be achieved by better interfaces to the network adapters [DALT 93] and by better integration of the protocol stack and its application.

We investigate *user level* protocol implementation that takes advantage of the demultiplexing functions being implemented on today's high-speed ATM adapters. A second argument for a user level implementation is to provide the application with a dedicated implementation of the protocol stack that allows better control over protocol processing to guarantee the QoS of the networked data [THEK 93, EDWA 94].

## 2 Concept

ATM (Asynchronous Transmission Mode) and its Adaptation Layer (AAL) offer a technology for the physical layer and the link layer of high-speed LANs and WANs. The AAL offers a connection-oriented frame transfer service on top of ATM. The AAL functions to reassemble a frame out of ATM cells are simple and must be executed at high speed. Therefore, the AAL is often implemented by dedicated processors on network adapters that offer the AAL service to the host system. Higher layer protocols can be implemented by mapping several higher layer connections onto a single AAL connection or by mapping each higher layer connection onto a dedicated AAL connection (*direct mapping*). This mapping can be done based on the number of possible AAL connections or based on performance and QoS criteria of the higher layer connection and application.

In this paper we examine the advantages of a direct mapping of a transport layer connection onto an AAL connection. We did the experiments with an implementation of the Internet protocols in the user space.

In a normal stack protocol, processing is done in a tree-like way. On each level branches are taken to demultiplex incoming PDUs to the correct higher layer protocol. The sum of these demultiplexing operations can take a considerable amount of time because in each layer the header must be parsed and the right connection control information must be found. While these operations are necessary to open a connection in a protocol stack, the normal dataflow case allows an optimized protocol handling. In the normal case, the protocol headers have the same format, no errors happen and consecutive PDUs for the same protocol belong to the same connection [CLAR 90]. If we assume that a protocol stack of a single connection is mapped directly onto a dedicated AAL connection then additional simplifications for protocol processing can be made.

All address information is known a-priori by the direct mapping. Therefore protocol handling can be simplified to the processing of the parameters that change and to exception handling. The stacked protocol headers are compared to a precomputed filter that looks for exception handling and for precomputed window information. If an exception is detected or if the header does not match the expected format, then the slow standard processing path is taken. If the filter matches an optimized processing path is taken that processes only the necessary steps, e.g., acknowledgments and timers. To allow an optimal matching of the filter the protocol parameters must be set to prevent segmentation.

## 3 Implementation

### 3.1 Multiplexed Protocol Stack in User Space

The internet protocol stack has been implemented in two steps. In the first step the code of IP, UDP, and TCP of the 4.3BSD has been ported to the user space of a Sun SPARC with SunOS Version 4.1.3. The goal was to build a library such that any application could chose either the system protocol stack or our library without any change. This implementation still multiplexes multiple transport connections onto a single ATM connection (see figure 1). The ATMcl layer in figure 1 performs the necessary adaptation between the connection-less IP and the connection-oriented ATM. Before the first IP datagram can be sent, an ATM connection is established. The ATM connection is released under timer control when no more IP datagrams are transmitted.

We changed the memory management of the protocol stack to use the mbuf structures on memory blocks allocated via a malloc system call. Our socket interface copies the user data to be sent into these memory structures where the subsequent protocol processing takes place. The protocols build packets by chaining the data and the headers in mbufs. Data to be sent are passed via a standard I/O interface to the AAL that is implemented on a SBA200 board from FORE Systems. A `select` call signals the reception of data on the same interface. Our network driver reads these data and hands them to IP, which forwards the transport layer PDU to TCP or UDP. The socket `receive` call gets the data from the transport layer and copies them to the user buffer. We use the Pthread library [MUEL 93] to implement a parallel timer thread that watches all outstanding timers.

### 3.2 Optimized Protocol Stack in User Space

In the second step we optimized the user space protocol implementation by a *direct mapping* between a transport connection and an AAL connection and a *packet filter*.

Each TCP connection is mapped onto a different ATM connection. The demultiplexing then takes only place at the ATM layer. This architecture is depicted in figure 2.

The packet filter looks for all the fields in the PDU that can be precomputed once the connection is established. As the addresses are known a priori, the filter matches only the fields that can change, e.g, IP segmentation and options, TCP flags and window,

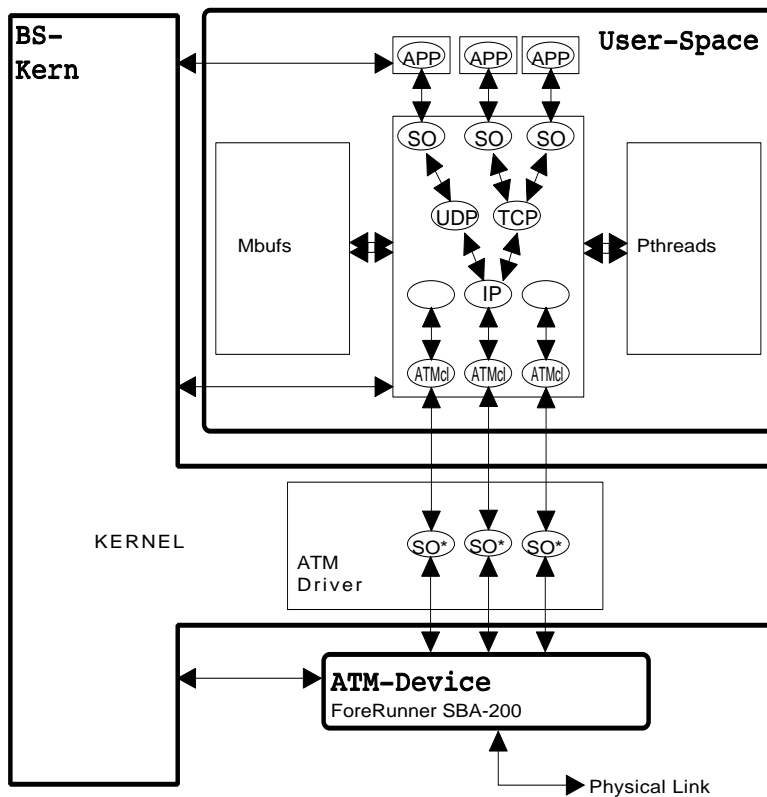

Figure 1: Architecture of the multiplex protocol stack in user space.

UDP flags. The algorithm is close to the header prediction algorithm of TCP by McCanne and Jacobson [MCCA 93] but is enhanced by the filtering of the IP header.

To implement the filter, the code for the receiver side of the IP and TCP/UDP was modified to distinguish between two different cases, the execution of which leads to two different paths (see figure 3):

- If the precomputed filter does not match, the *standard path* is executed that implements the full IP and TCP/UDP and can handle all options.
- If the precomputed filter does match, the *fast path* is executed, implementing a reduced version of IP and TCP/UDP. Here, a number of functions are suppressed, such as connection lookup, option processing, window adaptation, PCB-searching, or IP segmentation and checksum computation.

The decision which of the 2 paths to execute is taken by the filter that checks a certain number of fields in the header of IP and TCP/UDP. For IP and TCP these fields are highlighted in figure 4.

In the IP header, the filter checks if

- `VERS == 4`, i.e. the current version of IP is used
- `HLEN == 20`, i.e. the header is 20 bytes long and does not contain any IP options
- `SERVICE == 0`, i.e. there are no particular QOS requirements

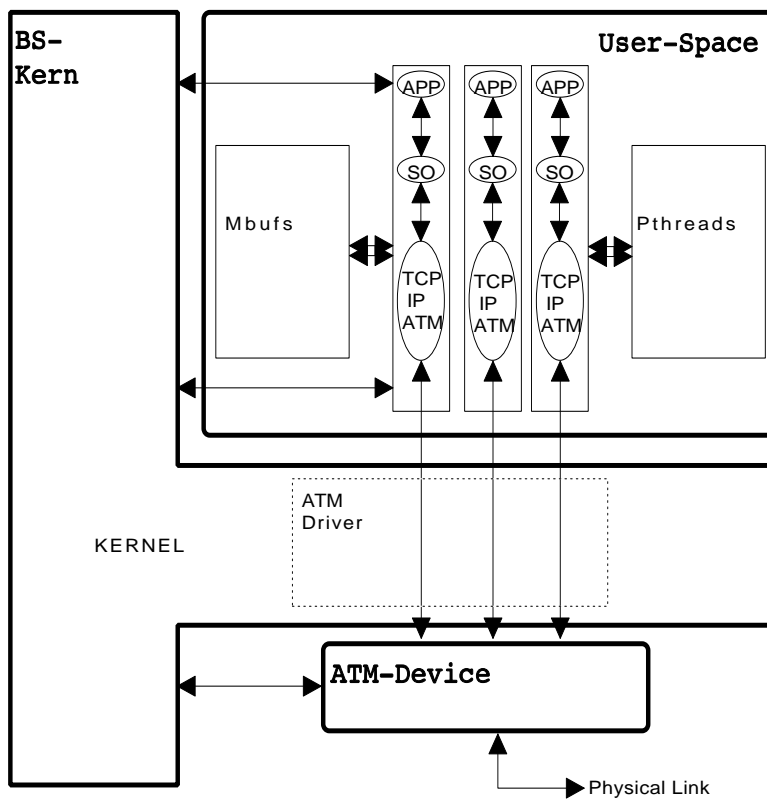

Figure 2: Architecture of the optimized protocol stack in user space.

- `FLAGS == 0`, i.e. there is no fragmentation
- `FRAGMENT-OFFSET == 0`, i.e. the IP datagram is not fragmented. We avoid fragmentation by choosing the maximum size for the TCP PDU such that it fits into a single AAL-5 PDU of 4096 Bytes.
- `PROTOCOL == 6`, to verify that TCP is used as transport protocol.

The filter matches on the TCP header iff

- The header does not contain any options (check of `HLEN`)
- The Flags `URG`, `SYS`, `FIN`, and `RST` are not set (check of `CODE-BITS`)
- The window size was not changed by the receiver (check of `WINDOW`).

If the standard path is taken, a filter adaptation is necessary when the window size was changed. In this case, the filter is adjusted to retain the new value of `WINDOW`. When the next PDU arrives, it can again become eligible for the fast path, provided that all the other predicates checked by the filter match.

Figure 5 shows that the fast path allows to suppress a certain number of functions.

When taking the fast path, at IP level

# Explore Litigation Insights

Docket Alarm provides insights to develop a more informed litigation strategy and the peace of mind of knowing you're on top of things.

## Real-Time Litigation Alerts



Keep your litigation team up-to-date with **real-time alerts** and advanced team management tools built for the enterprise, all while greatly reducing PACER spend.

Our comprehensive service means we can handle Federal, State, and Administrative courts across the country.

## Advanced Docket Research



With over 230 million records, Docket Alarm's cloud-native docket research platform finds what other services can't. Coverage includes Federal, State, plus PTAB, TTAB, ITC and NLRB decisions, all in one place.

Identify arguments that have been successful in the past with full text, pinpoint searching. Link to case law cited within any court document via Fastcase.

## Analytics At Your Fingertips



Learn what happened the last time a particular judge, opposing counsel or company faced cases similar to yours.

Advanced out-of-the-box PTAB and TTAB analytics are always at your fingertips.

## API

Docket Alarm offers a powerful API (application programming interface) to developers that want to integrate case filings into their apps.

## LAW FIRMS

Build custom dashboards for your attorneys and clients with live data direct from the court.

Automate many repetitive legal tasks like conflict checks, document management, and marketing.

## FINANCIAL INSTITUTIONS

Litigation and bankruptcy checks for companies and debtors.

## E-DISCOVERY AND LEGAL VENDORS

Sync your system to PACER to automate legal marketing.