

Under the Paperwork Reduction Act of 1995 no persons are required to respond to a collection of information unless it displays a valid OMB control number

PATENT - POWER OF ATTORNEY OR REVOCATION OF POWER OF ATTORNEY WITH A NEW POWER OF ATTORNEY AND CHANGE OF CORRESPONDENCE ADDRESS	Patent Number	6,736,759
	Issue Date	May 18, 2004
	First Named Inventor	Jack STUBBS
	Title	EXERCISE MONITORING SYSTEM AND METHODS
	Attorney Docket No.	UN-NP-MD-235

I hereby revoke all previous powers of attorney given in the above-identified patent.

A Power of Attorney is submitted herewith.

OR
 I hereby appoint Practitioner(s) associated with the Customer Number identified in the box at right as my/our attorney(s) or agent(s) with respect to the patent identified above, and to transact all business in the United States Patent and Trademark Office connected therewith:

96051

OR
 I hereby appoint Practitioner(s) named below as my/our attorney(s) or agent(s) with respect to the patent identified above, and to transact all business in the United States Patent and Trademark Office connected therewith:

Practitioner(s) Name	Registration Number

Please recognize or change the correspondence address for the above-identified patent to:

The address associated with the above-identified Customer Number.

OR
 The address associated with the Customer Number identified in the box at right:

Firm or Individual Name

Address

City

State

Zip

Country

Telephone

Email

I am the:

Applicant.

OR
 Patent owner.

Statement under 37 CFR 5.73(c) (Form PTO/AIA/96) submitted herewith or filed on _____.

SIGNATURE of Applicant or Patent Owner

Signature

Date

Name

Craig S. Etchegoyen

Telephone

Title and Company

CEO of Uniloc Luxembourg S.A.

NOTE: Signatures of all the applicants or patent owners of the entire interest or their representative(s) are required. If more than one signature is required, submit multiple forms, check the box below, and identify the total number of forms submitted in the blank below.

A total of _____ forms are submitted.

This collection of information is required by 37 CFR 1.31, 1.32, and 1.33. The information is required to obtain or retain a benefit by the public, which is to update (and by the USPTO to process) the file of a patent or reexamination proceeding. Confidentiality is governed by 35 U.S.C. 122 and 37 CFR 1.14. This collection is estimated to take 3 minutes to complete, including gathering, preparing, and submitting the completed application form to the USPTO. Time will vary depending upon the individual case. Any comments on the amount of time you require to complete this form and/or suggestions for reducing this burden, should be sent to the Chief Information Officer, U.S. Patent and Trademark Office, U.S. Department of Commerce, P.O. Box 1450, Alexandria, VA 22313-1450. DO NOT SEND FEES OR COMPLETED FORMS TO THIS ADDRESS. SEND TO: Commissioner for Patents, P.O. Box 1450, Alexandria, VA 22313-1450.

If you need assistance in completing the form, call 1-800-PTO-9199 and select option 2.

Electronic Acknowledgement Receipt

EFS ID:	30804445
Application Number:	09436515
International Application Number:	
Confirmation Number:	6756
Title of Invention:	EXERCISE MONITORING SYSTEM AND METHODS
First Named Inventor/Applicant Name:	JACK B. STUBBS
Customer Number:	24256
Filer:	Sean Dylan Burdick/Kris Pangan
Filer Authorized By:	Sean Dylan Burdick
Attorney Docket Number:	24278-1
Receipt Date:	30-OCT-2017
Filing Date:	09-NOV-1999
Time Stamp:	18:04:50
Application Type:	Utility under 35 USC 111(a)

Payment information:

Submitted with Payment	no
------------------------	----

File Listing:

Document Number	Document Description	File Name	File Size(Bytes)/ Message Digest	Multi Part /.zip	Pages (if appl.)
1	Assignee showing of ownership per 37 CFR 3.73	MD-235_Statement.pdf	142476 <small>bbbf78113d39dcdab25f385406d3dledca2b7bc8</small>	no	2

Warnings:

IPR2018-00294

Information:					
2	Power of Attorney	MD-235_POA.pdf	189825	no	1
			4425e082730260f6e3176f7402be9fba6ee482a6		
Warnings:					
Information:					
Total Files Size (in bytes):				332301	
<p>This Acknowledgement Receipt evidences receipt on the noted date by the USPTO of the indicated documents, characterized by the applicant, and including page counts, where applicable. It serves as evidence of receipt similar to a Post Card, as described in MPEP 503.</p> <p><u>New Applications Under 35 U.S.C. 111</u> If a new application is being filed and the application includes the necessary components for a filing date (see 37 CFR 1.53(b)-(d) and MPEP 506), a Filing Receipt (37 CFR 1.54) will be issued in due course and the date shown on this Acknowledgement Receipt will establish the filing date of the application.</p> <p><u>National Stage of an International Application under 35 U.S.C. 371</u> If a timely submission to enter the national stage of an international application is compliant with the conditions of 35 U.S.C. 371 and other applicable requirements a Form PCT/DO/EO/903 indicating acceptance of the application as a national stage submission under 35 U.S.C. 371 will be issued in addition to the Filing Receipt, in due course.</p> <p><u>New International Application Filed with the USPTO as a Receiving Office</u> If a new international application is being filed and the international application includes the necessary components for an international filing date (see PCT Article 11 and MPEP 1810), a Notification of the International Application Number and of the International Filing Date (Form PCT/RO/105) will be issued in due course, subject to prescriptions concerning national security, and the date shown on this Acknowledgement Receipt will establish the international filing date of the application.</p>					

Under the Paperwork Reduction Act of 1995, no persons are required to respond to a collection of information unless it displays a valid OMB control number.

STATEMENT UNDER 37 CFR 3.73(c)

Applicant/Patent Owner: Uniloc Luxembourg S.A.

Application No./Patent No.: 6,736,759 Filed/Issue Date: May 18, 2004

Titled: EXERCISE MONITORING SYSTEM AND METHODS

Uniloc Luxembourg S.A., a corporation

(Name of Assignee) (Type of Assignee, e.g., corporation, partnership, university, government agency, etc.)

states that, for the patent application/patent identified above, it is (choose **one** of options 1, 2, 3 or 4 below):

- 1. The assignee of the entire right, title, and interest.
- 2. An assignee of less than the entire right, title, and interest (check applicable box):
 - The extent (by percentage) of its ownership interest is _____%. Additional Statement(s) by the owners holding the balance of the interest must be submitted to account for 100% of the ownership interest.
 - There are unspecified percentages of ownership. The other parties, including inventors, who together own the entire right, title and interest are:

[Empty box for additional statement]

Additional Statement(s) by the owner(s) holding the balance of the interest must be submitted to account for the entire right, title, and interest.

- 3. The assignee of an undivided interest in the entirety (a complete assignment from one of the joint inventors was made). The other parties, including inventors, who together own the entire right, title, and interest are:

[Empty box for additional statement]

Additional Statement(s) by the owner(s) holding the balance of the interest must be submitted to account for the entire right, title, and interest.

- 4. The recipient, via a court proceeding or the like (e.g., bankruptcy, probate), of an undivided interest in the entirety (a complete transfer of ownership interest was made). The certified document(s) showing the transfer is attached.

The interest identified in option 1, 2 or 3 above (not option 4) is evidenced by either (choose **one** of options A or B below):

- A. An assignment from the inventor(s) of the patent application/patent identified above. The assignment was recorded in the United States Patent and Trademark Office at Reel _____, Frame _____, or for which a copy thereof is attached.
- B. A chain of title from the inventor(s), of the patent application/patent identified above, to the current assignee as follows:

1. From: Inventors To: Paragon Solution, LLC

The document was recorded in the United States Patent and Trademark Office at
Reel 010671, Frame 0655, or for which a copy thereof is attached.

2. From: Inventors To: Paragon Solutions, LLC

The document was recorded in the United States Patent and Trademark Office at
Reel 043294, Frame 0969, or for which a copy thereof is attached.

This collection of information is required by 37 CFR 3.73(b). The information is required to obtain or retain a benefit by the public which is to file (and by the USPTO to process) an application. Confidentiality is governed by 35 U.S.C. 122 and 37 CFR 1.11 and 1.14. This collection is estimated to take 12 minutes to complete, including gathering, preparing, and submitting the completed application form to the USPTO. Time will vary depending upon the individual case. Any comments on the amount of time you require to complete this form and/or suggestions for reducing this burden, should be sent to the Chief Information Officer, U.S. Patent and Trademark Office, U.S. Department of Commerce, P.O. Box 1450, Alexandria, VA 22313-1450. DO NOT SEND FEES OR COMPLETED FORMS TO THIS ADDRESS. **SEND TO: Commissioner for Patents, P.O. Box 1450, Alexandria, VA 22313-1450.**

If you need assistance in completing the form, call 1-800-PTO-9199 and select option 2.

IPR2018-00294

Apple Inc. EX1003 Page 4

Under the Paperwork Reduction Act of 1995, no persons are required to respond to a collection of information unless it displays a valid OMB control number.

STATEMENT UNDER 37 CFR 3.73(c)

3. From: Paragon Solutions, LLC To: Red Dragon Innovations, LLC

The document was recorded in the United States Patent and Trademark Office at
Reel 042677, Frame 0549, or for which a copy thereof is attached.

4. From: Paragon Solutions, LLC To: Red Dragon Innovations, LLC

The document was recorded in the United States Patent and Trademark Office at
Reel 043135, Frame 0664, or for which a copy thereof is attached.

5. From: Red Dragon Innovations, LLC To: Uniloc Luxembourg S.A.

The document was recorded in the United States Patent and Trademark Office at
Reel 043751, Frame 0041, or for which a copy thereof is attached.

6. From: _____ To: _____

The document was recorded in the United States Patent and Trademark Office at
Reel _____, Frame _____, or for which a copy thereof is attached.

Additional documents in the chain of title are listed on a supplemental sheet(s).

As required by 37 CFR 3.73(c)(1)(i), the documentary evidence of the chain of title from the original owner to the assignee was, or concurrently is being, submitted for recordation pursuant to 37 CFR 3.11.

[NOTE: A separate copy (i.e., a true copy of the original assignment document(s)) must be submitted to Assignment Division in accordance with 37 CFR Part 3, to record the assignment in the records of the USPTO. See MPEP 302.08]

The undersigned (whose title is supplied below) is authorized to act on behalf of the assignee.

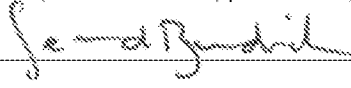
Signature

October 30, 2017
Date

Sean D. Burdick
Printed or Typed Name

51,513
Title or Registration Number

**CERTIFICATION OF MICRO ENTITY STATUS
 (GROSS INCOME BASIS)**

Application Number or Control Number (if applicable): 09/436,515	Patent Number (if applicable): 6,736,759
First Named Inventor: JACK B. STUBBS	Title of Invention: EXERCISE MONITORING SYSTEM AND METHODS

The applicant hereby certifies the following—

- (1) **SMALL ENTITY REQUIREMENT** – The applicant qualifies as a small entity as defined in 37 CFR 1.27.
- (2) **APPLICATION FILING LIMIT** – Neither the applicant nor the inventor nor a joint inventor has been named as the inventor or a joint inventor on more than four previously filed U.S. patent applications, excluding provisional applications and international applications under the Patent Cooperation Treaty (PCT) for which the basic national fee under 37 CFR 1.492(a) was not paid, and also excluding patent applications for which the applicant has assigned all ownership rights, or is obligated to assign all ownership rights, as a result of the applicant’s previous employment.
- (3) **GROSS INCOME LIMIT ON APPLICANTS AND INVENTORS** – Neither the applicant nor the inventor nor a joint inventor, in the calendar year preceding the calendar year in which the applicable fee is being paid, had a gross income, as defined in section 61(a) of the Internal Revenue Code of 1986 (26 U.S.C. 61(a)), exceeding the “Maximum Qualifying Gross Income” reported on the USPTO Web site at http://www.uspto.gov/patents/law/micro_entity.jsp which is equal to three times the median household income for that preceding calendar year, as most recently reported by the Bureau of the Census.
- (4) **GROSS INCOME LIMIT ON PARTIES WITH AN “OWNERSHIP INTEREST”** – Neither the applicant nor the inventor nor a joint inventor has assigned, granted, or conveyed, nor is under an obligation by contract or law to assign, grant, or convey, a license or other ownership interest in the application concerned to an entity that, in the calendar year preceding the calendar year in which the applicable fee is being paid, had a gross income, as defined in section 61(a) of the Internal Revenue Code of 1986, exceeding the “Maximum Qualifying Gross Income” reported on the USPTO Web site at http://www.uspto.gov/patents/law/micro_entity.jsp which is equal to three times the median household income for that preceding calendar year, as most recently reported by the Bureau of the Census.

SIGNATURE by an authorized party set forth in 37 CFR 1.33(b)

Signature	/Vance V. VanDrake, III/				
Name	Vance V. VanDrake, III				
Date	May 22, 2015	Telephone	513-698-5158	Registration No.	50,459



There is more than one inventor and I am one of the inventors who are jointly identified as the applicant. The required additional certification form(s) signed by the other joint inventor(s) are included with this form.

Privacy Act Statement

The **Privacy Act of 1974 (P.L. 93-579)** requires that you be given certain information in connection with your submission of the attached form related to a patent application or patent. Accordingly, pursuant to the requirements of the Act, please be advised that: (1) the general authority for the collection of this information is 35 U.S.C. 2(b)(2); (2) furnishing of the information solicited is voluntary; and (3) the principal purpose for which the information is used by the U.S. Patent and Trademark Office is to process and/or examine your submission related to a patent application or patent. If you do not furnish the requested information, the U.S. Patent and Trademark Office may not be able to process and/or examine your submission, which may result in termination of proceedings or abandonment of the application or expiration of the patent.

The information provided by you in this form will be subject to the following routine uses:

1. The information on this form will be treated confidentially to the extent allowed under the Freedom of Information Act (5 U.S.C. 552) and the Privacy Act (5 U.S.C. 552a). Records from this system of records may be disclosed to the Department of Justice to determine whether disclosure of these records is required by the Freedom of Information Act.
2. A record from this system of records may be disclosed, as a routine use, in the course of presenting evidence to a court, magistrate, or administrative tribunal, including disclosures to opposing counsel in the course of settlement negotiations.
3. A record in this system of records may be disclosed, as a routine use, to a Member of Congress submitting a request involving an individual, to whom the record pertains, when the individual has requested assistance from the Member with respect to the subject matter of the record.
4. A record in this system of records may be disclosed, as a routine use, to a contractor of the Agency having need for the information in order to perform a contract. Recipients of information shall be required to comply with the requirements of the Privacy Act of 1974, as amended, pursuant to 5 U.S.C. 552a(m).
5. A record related to an International Application filed under the Patent Cooperation Treaty in this system of records may be disclosed, as a routine use, to the International Bureau of the World Intellectual Property Organization, pursuant to the Patent Cooperation Treaty.
6. A record in this system of records may be disclosed, as a routine use, to another federal agency for purposes of National Security review (35 U.S.C. 181) and for review pursuant to the Atomic Energy Act (42 U.S.C. 218(c)).
7. A record from this system of records may be disclosed, as a routine use, to the Administrator, General Services, or his/her designee, during an inspection of records conducted by GSA as part of that agency's responsibility to recommend improvements in records management practices and programs, under authority of 44 U.S.C. 2904 and 2906. Such disclosure shall be made in accordance with the GSA regulations governing inspection of records for this purpose, and any other relevant (*i.e.*, GSA or Commerce) directive. Such disclosure shall not be used to make determinations about individuals.
8. A record from this system of records may be disclosed, as a routine use, to the public after either publication of the application pursuant to 35 U.S.C. 122(b) or issuance of a patent pursuant to 35 U.S.C. 151. Further, a record may be disclosed, subject to the limitations of 37 CFR 1.14, as a routine use, to the public if the record was filed in an application which became abandoned or in which the proceedings were terminated and which application is referenced by either a published application, an application open to public inspection or an issued patent.
9. A record from this system of records may be disclosed, as a routine use, to a Federal, State, or local law enforcement agency, if the USPTO becomes aware of a violation or potential violation of law or regulation.

Electronic Acknowledgement Receipt

EFS ID:	22425991
Application Number:	09436515
International Application Number:	
Confirmation Number:	6756
Title of Invention:	EXERCISE MONITORING SYSTEM AND METHODS
First Named Inventor/Applicant Name:	JACK B. STUBBS
Customer Number:	24256
Filer:	Vance Victor VanDrake III/Theresa Davis
Filer Authorized By:	Vance Victor VanDrake III
Attorney Docket Number:	24278-1
Receipt Date:	22-MAY-2015
Filing Date:	09-NOV-1999
Time Stamp:	13:33:42
Application Type:	Utility under 35 USC 111(a)

Payment information:

Submitted with Payment	no
------------------------	----

File Listing:

Document Number	Document Description	File Name	File Size(Bytes)/ Message Digest	Multi Part /.zip	Pages (if appl.)
1	Certification of Micro Entity (Gross Income Basis)	6736759_MicroEntityStatus.pdf	120673 <small>adc35f50c91ee285b3b3e2ca1e88f41e3e247f94</small>	no	2

Warnings:

Information:

IPR2018-00294

This Acknowledgement Receipt evidences receipt on the noted date by the USPTO of the indicated documents, characterized by the applicant, and including page counts, where applicable. It serves as evidence of receipt similar to a Post Card, as described in MPEP 503.

New Applications Under 35 U.S.C. 111

If a new application is being filed and the application includes the necessary components for a filing date (see 37 CFR 1.53(b)-(d) and MPEP 506), a Filing Receipt (37 CFR 1.54) will be issued in due course and the date shown on this Acknowledgement Receipt will establish the filing date of the application.

National Stage of an International Application under 35 U.S.C. 371

If a timely submission to enter the national stage of an international application is compliant with the conditions of 35 U.S.C. 371 and other applicable requirements a Form PCT/DO/EO/903 indicating acceptance of the application as a national stage submission under 35 U.S.C. 371 will be issued in addition to the Filing Receipt, in due course.

New International Application Filed with the USPTO as a Receiving Office

If a new international application is being filed and the international application includes the necessary components for an international filing date (see PCT Article 11 and MPEP 1810), a Notification of the International Application Number and of the International Filing Date (Form PCT/RO/105) will be issued in due course, subject to prescriptions concerning national security, and the date shown on this Acknowledgement Receipt will establish the international filing date of the application.



UNITED STATES PATENT AND TRADEMARK OFFICE

UNITED STATES DEPARTMENT OF COMMERCE
United States Patent and Trademark Office
Address: COMMISSIONER FOR PATENTS
P.O. Box 1450
Alexandria, Virginia 22313-1450
www.uspto.gov

APPLICATION NO.	FILING DATE	FIRST NAMED INVENTOR	ATTORNEY DOCKET NO.	CONFIRMATION NO.
09/436,515	11/09/1999	JACK B. STUBBS	24278-1	6756

24256 7590 03/05/2004

DINSMORE & SHOHL, LLP
1900 CHEMED CENTER
255 EAST FIFTH STREET
CINCINNATI, OH 45202

EXAMINER

RICHMAN, GLENN E

ART UNIT PAPER NUMBER

3764

DATE MAILED: 03/05/2004

Please find below and/or attached an Office communication concerning this application or proceeding.

Response to Rule 312 Communication	Application No. 09/436,515	Applicant(s) STUBBS ET AL.	
	Examiner Glenn Richman	Art Unit 3764	

-- The MAILING DATE of this communication appears on the cover sheet with the correspondence address --

1. The amendment filed on 24 October 2003 under 37 CFR 1.312 has been considered, and has been:
- a) entered.
 - b) entered as directed to matters of form not affecting the scope of the invention.
 - c) disapproved because the amendment was filed after the payment of the issue fee.
Any amendment filed after the date the issue fee is paid must be accompanied by a petition under 37 CFR 1.313(c)(1) and the required fee to withdraw the application from issue.
 - d) disapproved. See explanation below.
 - e) entered in part. See explanation below.

Glenn Richman
Primary Examiner
Art Unit: 3764



#23
3180A
507

Express Mail Label No. EL 993415299 US

Practitioner's Docket No. 393085

PATENT

IN THE UNITED STATES PATENT AND TRADEMARK OFFICE

In re application of: Victor F. Petrenko
Application No.: 09/857,397
Filed: 31 May 2001

Group No.: 3742
Examiner: Q. Van
Confirmation No.: 3029

For: METHODS AND STRUCTURES FOR REMOVING ICE FROM SURFACES

MAIL STOP ISSUE FEE
Commissioner for Patents
P.O. Box 1450
Alexandria, VA 22313-1450

COMMENTS ON STATEMENT OF REASONS FOR ALLOWANCE

The Examiner has cited reasons for allowance in this application in connection with the Notice of Allowance mailed 24 October 2003. Applicant wishes to point out that there are many additional reasons for allowance, including features of independent and dependent claims not specifically referenced in the Notice of Allowance.

Respectfully submitted,

Date: 12/12/03

By Curtis A. Vock
Curtis A. Vock, Reg. No. 38,356
LATHROP & GAGE L.C.
4845 Pearl East Circle, Suite 300
Boulder, CO 80301
Tel: (720) 931-3011
Fax: (720) 931-3001

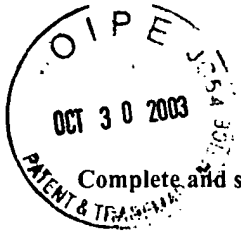

PART B - FEE(S) TRANSMITTAL

Complete and send this form, together with applicable fee(s), to: **Mail** Mail Stop ISSUE FEE
Commissioner for Patents
Alexandria, Virginia 22313-1450
Fax (703)746-4000

INSTRUCTIONS: This form should be used for transmitting the ISSUE FEE and PUBLICATION FEE (if required). Blocks 1 through 4 should be completed where appropriate. All further correspondence including the Patent, advance orders and notification of maintenance fees will be mailed to the current correspondence address as indicated unless corrected below or directed otherwise in Block 1, by (a) specifying a new correspondence address; and/or (b) indicating a separate "FEE ADDRESS" for maintenance fee notifications.

CURRENT CORRESPONDENCE ADDRESS (Note: Legibly mark-up with any corrections or use Block 1)
7590 07/29/2003

Note: A certificate of mailing can only be used for domestic mailings of the Fee(s) Transmittal. This certificate cannot be used for any other accompanying papers. Each additional paper, such as an assignment or formal drawing, must have its own certificate of mailing or transmission.

DINSMORE AND SHOHL LLP
1900 CHEMED CENTER
255 EAST FIFTH STREET
CINCINNATI, OH 45202

Certificate of Mailing or Transmission
I hereby certify that this Fee(s) Transmittal is being deposited with the United States Postal Service with sufficient postage for first class mail in an envelope addressed to the Box Issue Fee address above, or being facsimile transmitted to the USPTO, on the date indicated below.

Stephanie Berlepsch (Depositor's name)
Stephanie Berlepsch (Signature)
October 27, 2003 (Date)

APPLICATION NO.	FILING DATE	FIRST NAMED INVENTOR	ATTORNEY DOCKET NO.	CONFIRMATION NO.
09/436,515	11/09/1999	JACK B. STUBBS	24278-1	6756

TITLE OF INVENTION: EXERCISE MONITORING SYSTEM AND METHODS

APPLN. TYPE	SMALL ENTITY	ISSUE FEE	PUBLICATION FEE	TOTAL FEE(S) DUE	DATE DUE
nonprovisional	YES	\$650	\$0	\$650	10/29/2003

EXAMINER	ART UNIT	CLASS-SUBCLASS
RICHMAN, GLENN E	3764	482-008000

1. Change of correspondence address or indication of "Fee Address" (37 CFR 1.363).
 Change of correspondence address (or Change of Correspondence Address form PTO/SB/122) attached.
 "Fee Address" indication (or "Fee Address" Indication form PTO/SB/47; Rev 03-02 or more recent) attached. **Use of a Customer Number is required.**

2. For printing on the patent front page, list (1) the names of up to 3 registered patent attorneys or agents OR, alternatively, (2) the name of a single firm (having as a member a registered attorney or agent) and the names of up to 2 registered patent attorneys or agents. If no name is listed, no name will be printed.

Dinsmore & Shohl LLP
1 _____
2 _____
3 _____

3. ASSIGNEE NAME AND RESIDENCE DATA TO BE PRINTED ON THE PATENT (print or type)

PLEASE NOTE: Unless an assignee is identified below, no assignee data will appear on the patent. Inclusion of assignee data is only appropriate when an assignment has been previously submitted to the USPTO or is being submitted under separate cover. Completion of this form is NOT a substitute for filing an assignment.

(A) NAME OF ASSIGNEE: Paragon Solutions, LLC
(B) RESIDENCE: (CITY and STATE OR COUNTRY) Waynesville, Ohio

Please check the appropriate assignee category or categories (will not be printed on the patent) individual corporation or other private group entity government

4a. The following fee(s) are enclosed:
 Issue Fee
 Publication Fee
 Advance Order - # of Copies _____

4b. Payment of Fee(s):
 A check in the amount of the fee(s) is enclosed.
 Payment by credit card. Form PTO-2038 is attached.
 The Commissioner is hereby authorized by charge **any deficiencies** (enclose an extra copy of this form).
Deposit Account Number 04 1122

Commissioner for Patents is requested to apply the Issue Fee and Publication Fee (if any) or to re-apply any previously paid issue fee to the application identified above.

(Authorized Signature) *Martin J. Miller* (Date) 9-27-03

NOTE: The Issue Fee and Publication Fee (if required) will not be accepted from anyone other than the applicant; a registered attorney or agent; or the assignee or other party in interest as shown by the records of the United States Patent and Trademark Office.

This collection of information is required by 37 CFR 1.311. The information is required to obtain or retain a benefit by the public which is to file (and by the USPTO to process) an application. Confidentiality is governed by 35 U.S.C. 122 and 37 CFR 1.14. This collection is estimated to take 12 minutes to complete, including gathering, preparing, and submitting the completed application form to the USPTO. Time will vary depending upon the individual case. Any comments on the amount of time you require to complete this form and/or suggestions for reducing this burden, should be sent to the Chief Information Officer, U.S. Patent and Trademark Office, U.S. Department of Commerce, Alexandria, Virginia 22313-1450. **DO NOT SEND FEES OR COMPLETED FORMS TO THIS ADDRESS. SEND TO: Commissioner for Patents, Alexandria, Virginia 22313-1450.**

Under the Paperwork Reduction Act of 1995, no persons are required to respond to a collection of information unless it displays a valid OMB control number.

10/31/2003 SFELEKE2 00000002 09436515
01 FC:2501 665.00 OP

TRANSMIT THIS FORM WITH FEE(S)

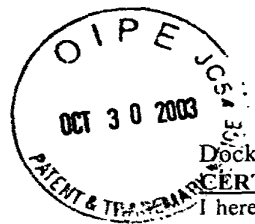

Docket No: 24278-1

CERTIFICATE OF MAILING

I hereby certify that this paper is being deposited with the United States Postal Service with sufficient postage as first class mail in an envelope addressed to: Mail Stop Issue Fee; Commissioner for Patents, P.O. Box 1450, Alexandria, VA 22313-1450 on Oct 27 2003.

Stephanie Berlepsch
Stephanie Berlepsch

B. J. P.
PATENT

NOA Date: July 29, 2003

IN THE UNITED STATES PATENT & TRADEMARK OFFICE

Applicant:	Jack B. Stubbs et al.	Paper No.:	
Serial No.:	09/436,515	Group Art Unit:	3764
Filed:	November 9, 1999	Examiner:	Glenn E. Richman
For:	Exercise Monitoring System and Methods		

TRANSMITTAL OF ISSUE FEE PAYMENT

Mail Stop Issue Fee
Commissioner for Patents
P.O. Box 1450
Alexandria, VA 22313-1450

Dear Sir:

Attached please find the Fee Transmittal form (PTOL-85) as well as credit card form PTO-2038 in the amount of \$665.00 for payment of the issue fee in the above-referenced application. Please charge any additional fees required, and credit any overpayment, to Deposit Account No. 04-1133.

Respectfully submitted,

By: *Martin J. Miller*
 Martin J. Miller
 Registration No. 35,953
 Attorney for Applicant(s)
 DINSMORE & SHOHL, LLP
 1900 Chemed Center
 255 East Fifth Street
 Cincinnati, Ohio 45202
 (513) 977-8565

OCT 30 2003
 PATENT & TRADEMARK OFFICE

GA

PART B - FEE(S) TRANSMITTAL

Complete and send this form, together with applicable fee(s), to: **Mail** Mail Stop **ISSUE FEE**
 Commissioner for Patents
 Alexandria, Virginia 22313-1450
Fax (703)746-4000

INSTRUCTIONS: This form should be used for transmitting the **ISSUE FEE** and **PUBLICATION FEE** (if required). Blocks 1 through 4 should be completed where appropriate. All further correspondence including the Patent, advance orders and notification of maintenance fees will be mailed to the current correspondence address as indicated unless corrected below or directed otherwise in Block 1, by (a) specifying a new correspondence address; and/or (b) indicating a separate "FEE ADDRESS" for maintenance fee notifications.

CURRENT CORRESPONDENCE ADDRESS (Note: Legibly mark-up with any corrections or use Block 1)

7590 07/29/2003
DINSMORE AND SHOHL LLP
 1900 CHEMED CENTER
 255 EAST FIFTH STREET
 CINCINNATI, OH 45202

Note: A certificate of mailing can only be used for domestic mailings of the Fee(s) Transmittal. This certificate cannot be used for any other accompanying papers. Each additional paper, such as an assignment or formal drawing, must have its own certificate of mailing or transmission.

Certificate of Mailing or Transmission
 I hereby certify that this Fee(s) Transmittal is being deposited with the United States Postal Service with sufficient postage for first class mail in an envelope addressed to the Box Issue Fee address above, or being facsimile transmitted to the USPTO, on the date indicated below.

Stephanie Berlepsch	(Depositor's name)
<i>Stephanie Berlepsch</i>	(Signature)
October 27, 2003	(Date)

APPLICATION NO.	FILING DATE	FIRST NAMED INVENTOR	ATTORNEY DOCKET NO.	CONFIRMATION NO.
09/436,515	11/09/1999	JACK B. STUBBS	24278-1	6756

TITLE OF INVENTION: EXERCISE MONITORING SYSTEM AND METHODS

APPLN. TYPE	SMALL ENTITY	ISSUE FEE	PUBLICATION FEE	TOTAL FEE(S) DUE	DATE DUE
nonprovisional	YES	\$650	\$0	\$650	10/29/2003

EXAMINER	ART UNIT	CLASS-SUBCLASS
RICHMAN, GLENN E	3764	482-008000

1. Change of correspondence address or indication of "Fee Address" (37 CFR 1.363). <input type="checkbox"/> Change of correspondence address (or Change of Correspondence Address form PTO/SB/122) attached. <input type="checkbox"/> "Fee Address" indication (or "Fee Address" Indication form PTO/SB/47; Rev 03-02 or more recent) attached. Use of a Customer Number is required.	2. For printing on the patent front page, list (1) the names of up to 3 registered patent attorneys or agents OR, alternatively, (2) the name of a single firm (having as a member a registered attorney or agent) and the names of up to 2 registered patent attorneys or agents. If no name is listed, no name will be printed.	Dinsmore & Shohl LLP 1 _____ 2 _____ 3 _____
---------------------------------------------------------------------------------------------------------------------------------------------------------------------------------------------------------------------------------------------------------------------------------------------------------------------------------------------------------------------------------------------	-----------------------------------------------------------------------------------------------------------------------------------------------------------------------------------------------------------------------------------------------------------------------------------------------------------------------------------	-------------------------------------------------------

3. ASSIGNEE NAME AND RESIDENCE DATA TO BE PRINTED ON THE PATENT (print or type)
 PLEASE NOTE: Unless an assignee is identified below, no assignee data will appear on the patent. Inclusion of assignee data is only appropriate when an assignment has been previously submitted to the USPTO or is being submitted under separate cover. Completion of this form is NOT a substitute for filing an assignment.
 (A) NAME OF ASSIGNEE: **Paragon Solutions, LLC**
 (B) RESIDENCE: (CITY and STATE OR COUNTRY) **Waynesville, Ohio**

Please check the appropriate assignee category or categories (will not be printed on the patent) individual corporation or other private group entity government

4a. The following fee(s) are enclosed:
 Issue Fee
 Publication Fee
 Advance Order - # of Copies _____

4b. Payment of Fee(s):
 A check in the amount of the fee(s) is enclosed.
 Payment by credit card. Form PTO-2038 is attached. **any deficiencies**
 The Commissioner is hereby authorized by charge ~~to the USPTO~~ **04 1133** (enclose an extra copy of this form).

Commissioner for Patents is requested to apply the Issue Fee and Publication Fee (if any) or to re-apply any previously paid issue fee to the application identified above.

(Authorized Signature) *Martin J. Miller* (Date) **9-27-03**

NOTE: The Issue Fee and Publication Fee (if required) will not be accepted from anyone other than the applicant, a registered attorney or agent, or the assignee or other party in interest as shown by the records of the United States Patent and Trademark Office.
 This collection of information is required by 37 CFR 1.311. The information is required to obtain or retain a benefit by the public which is to file (and by the USPTO to process) an application. Confidentiality is governed by 35 U.S.C. 122 and 37 CFR 1.14. This collection is estimated to take 12 minutes to complete, including gathering, preparing, and submitting the completed application form to the USPTO. Time will vary depending upon the individual case. Any comments on the amount of time you require to complete this form and/or suggestions for reducing this burden, should be sent to the Chief Information Officer, U.S. Patent and Trademark Office, U.S. Department of Commerce, Alexandria, Virginia 22313-1450. **DO NOT SEND FEES OR COMPLETED FORMS TO THIS ADDRESS. SEND TO: Commissioner for Patents, Alexandria, Virginia 22313-1450.**
 Under the Paperwork Reduction Act of 1995, no persons are required to respond to a collection of information unless it displays a valid OMB control number.

10/31/2003 SFELEKE2 00000002 09436515
 01 FC:2501 665.00 0P

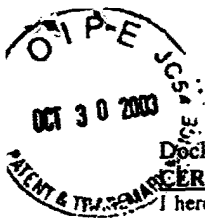

Docket No: 24278-1

CERTIFICATE OF MAILING

I hereby certify that this paper is being deposited with the United States Postal Service with sufficient postage as first class mail in an envelope addressed to: Mail Stop Issue Fee; Commissioner for Patents, P.O. Box 1450, Alexandria, VA 22313-1450 on October 27 2003.

Stephanie Berlepsch
Stephanie Berlepsch

B/S
PATENT

NOA Date: July 29, 2003

IN THE UNITED STATES PATENT & TRADEMARK OFFICE

Applicant:	Jack B. Stubbs et al.	Paper No.:	
Serial No.:	09/436,515	Group Art Unit:	3764
Filed:	November 9, 1999	Examiner:	Glenn E. Richman
For:	Exercise Monitoring System and Methods		

TRANSMITTAL OF ISSUE FEE PAYMENT

Mail Stop Issue Fee
Commissioner for Patents
P.O. Box 1450
Alexandria, VA 22313-1450

Dear Sir:

Attached please find the Fee Transmittal form (PTOL-85) as well as credit card form PTO-2038 in the amount of \$665.00 for payment of the issue fee in the above-referenced application. Please charge any additional fees required, and credit any overpayment, to Deposit Account No. 04-1133.

Respectfully submitted,

By: *Martin J. Miller*
 Martin J. Miller
 Registration No. 36,953
 Attorney for Applicant(s)
 DINSMORE & SHOHL, LLP
 1900 Chemed Center
 255 East Fifth Street
 Cincinnati, Ohio 45202
 (513) 977-8565

954853.1

OCT. 24. 2003 3:28PM

NO. 0173 - P. 5

#20 / (S) (NS)
JK
PATENT 102903

Docket No: 24278-1

CERTIFICATE OF MAILING

I hereby certify that this paper is being deposited with the United States Postal Service with sufficient postage as first class mail in an envelope addressed to: Mail Stop Non-Fee Amendment; Commissioner for Patents; P.O. Box 1450; Alexandria, VA 22313-1450 on September 18, 2003.

Stephanie Berlepsch
Stephanie Berlepsch

IN THE UNITED STATES PATENT & TRADEMARK OFFICE

Applicant(s): Jack B. Stubbs, et al.	:	Paper No.:
Serial No.: 09/436,515	:	Group Art Unit: 3764
Filed: November 9, 1999	:	Examiner: G. E. Richman
For: Exercise Monitoring System and Methods		

AMENDMENT UNDER 37 CFR §1.312

Mail Stop Non-Fee Amendment
Commissioner for Patents
P.O. Box 1450
Alexandria, VA 22313-1450

RECEIVED
OCT 24 2003
Group 3700

Dear Sir:

Pursuant to 37 CFR § 1.312 and MPEP § 714.16, Applicant requests that the above application be amended as follows:

Amendments to the Claims are reflected in the listing of claims which begins on page 2 of this paper.

Remarks begin on page 8 of this paper.

OCT. 24. 2003 3:29PM

Amendments to the Claims:

This listing of claims will replace all prior versions, and listings, of claims in the application.

Claim 1 (previously presented): An exercise monitoring system, comprising:

- (a) a data acquisition unit comprising an electronic positioning device and a physiological monitor, said data acquisition unit configured to be worn by a subject performing a physical activity; and
- (b) a display unit configured for displaying real-time data provided by said electronic positioning device and said physiological monitor, said display unit separate from said data acquisition unit;

wherein said display unit is configured to be worn by the subject, worn by someone other than the subject, or attached to an apparatus associated with the physical activity being performed by the subject so as to be visible to the subject while performing the physical activity, and

further wherein said system is configured such that said display unit displays real-time data comprising at least one of a subject's location, altitude, velocity, pace, and distance traveled.

Claim 2 (original): The exercise monitoring system of claim 1, wherein said electronic positioning device is configured to receive electromagnetic signals from three or more sources so that said monitoring system can determine at least one of a subject's location, altitude, velocity, pace, and distance traveled.

Claim 3 (previously presented): The system of claim 1, wherein said electronic positioning device comprises a GPS device.

Claim 4 (original): The system of claim 1, wherein said physiological monitor is chosen from the group consisting of: an oximeter and a heart rate monitor.

Claim 5 (original): The system of claim 4, wherein said electronic positioning device comprises a GPS device.

Claim 6 (canceled)

OCT. 24. 2003 3:29PM

⁶
Claim ~~7~~ (previously presented): The system of claim 1, wherein said electronic positioning device comprises a GPS device, and further wherein said data acquisition unit further comprises a support member, and said GPS device and said physiological monitor are provided on said support member.

⁷
Claim ~~8~~ (original): The system of claim ~~7~~⁶, wherein said GPS device and said physiological monitor are removably secured to said support member.

⁸
Claim ~~9~~ (previously presented): The system of claim 1, wherein said data acquisition unit is configured to be worn about a human user's waist.

⁹
Claim ~~10~~ (previously presented): The system of claim 1, wherein said data acquisition unit is configured to be worn about a human user's chest.

¹⁰
Claim ~~11~~ (original): The system of claim 1, wherein said display unit is configured to be worn about a human user's wrist.

¹¹
Claim ~~12~~ (original): The system of claim 1, wherein said display unit is configured to be mounted to a bicycle.

Claim 13 (canceled)

¹²
Claim ~~14~~ (original): The system of claim 1, wherein said physiological monitor includes a probe configured for acquiring physiological data from a user.

¹³
Claim ~~15~~ (original): The system of claim 4, wherein said physiological monitor comprises an oximeter.

¹⁴
Claim ~~16~~ (original): The system of claim 4, wherein said physiological monitor comprises a heart rate monitor.

¹⁵
Claim ~~17~~ (original): The system of claim 1, wherein said system further comprises an alarm which is activated when data provided by at least one of said electronic

OCT. 24. 2003 3:29PM

positioning device and said physiological monitor does not meet a predetermined target.

29

Claim ~~18~~ (currently amended): An exercise monitoring system, comprising:

- (a) an electronic positioning device configured to receive electromagnetic signals from three or more sources so that said monitoring system can determine at least one of a subject's velocity or pace, wherein said electronic positioning device is provided as part of a data acquisition unit;
- (b) a physiological monitor;
- ~~(b)~~(c) a display unit configured to be worn by a user and for simultaneously displaying real-time data provided by said electronic positioning device and said physiological monitor, wherein said display unit is separate from said electronic positioning device; and
- ~~(c)~~(d) an alarm, wherein said alarm is activated when a subject's velocity or pace does not meet a predetermined target.

Claims 19-59 (canceled)

17

Claim ~~60~~ (previously presented): The exercise monitoring system of claim 1, wherein said display unit comprises a heads-up type display unit configured to display said data by projecting the data onto glasses, goggles or a visor, or by projecting the data onto a display screen positioned such that the data will be visible to a user.

Claim 61 (canceled)

18

Claim ~~62~~ (previously presented): The exercise monitoring system of claim 1, wherein said system is configured such that the display unit simultaneously displays: at least one of a subject's velocity, pace and distance traveled; and physiological data provided by said physiological monitor.

19

Claim ~~63~~ (previously presented): The exercise monitoring system of claim 1, wherein said system further comprises at least one memory, and at least one

OCT. 24. 2003 3:29PM

processor for processing acquired data in accordance with instructions stored in said at least one memory.

²⁰ Claim ~~64~~ (previously presented): The exercise monitoring system of claim ~~63~~,¹⁹ wherein said data acquisition unit includes memory, and at least one processor for processing acquired data in accordance with instructions stored in said memory of the data acquisition unit, and further wherein said display unit includes memory, and at least one processor for processing acquired data in accordance with instructions stored in said memory of the display unit.

²¹ Claim ~~65~~ (previously presented): The exercise monitoring system of claim ~~63~~,¹⁹ wherein said at least one memory is configured for storing acquired data for later retrieval.

²² Claim ~~66~~ (previously presented): The exercise monitoring system of claim 1, wherein said display unit is configured for communication with said data acquisition unit via a wired or wireless link, such that data indicative of at least one of a subject's velocity or pace can be transmitted to said display unit.

²³ Claim ~~67~~ (previously presented): The exercise monitoring system of claim ~~66~~,²² wherein said display unit is configured for communication with said data acquisition unit via radio waves.

²⁴ Claim ~~68~~ (previously presented): The exercise monitoring system of claim 1, wherein said system is configured for computing a subject's workload based on the subject's velocity and altitude changes, and displaying the computed workload.

²⁵ Claim ~~69~~ (previously presented): The exercise monitoring system of claim ~~68~~,²⁴ wherein said system is configured for the input of a subject's weight, and said system is configured for computing a subject's workload based on the subject's velocity, altitude changes and inputted weight.

OCT. 24. 2003 3:30PM

²⁶
Claim ~~70~~ (previously presented): The exercise monitoring system of claim 1, wherein said system is configured for electrical communication with an external computer such that acquired data may be stored in the computer.

²⁷
Claim ~~71~~ (previously presented): The exercise monitoring system of claim ~~71~~,¹⁵ wherein said physiological monitor comprises an oximeter, and wherein said system is configured such that said alarm is activated when a subject's blood oxygen level does not meet a predetermined target.

²⁸
Claim ~~72~~ (previously presented): The exercise monitoring system of claim ~~71~~,²⁷ wherein said system is configured such that a plurality of predetermined targets for blood oxygen level may be input into said system.

¹⁶
Claim ~~73~~ (previously presented): The exercise monitoring system of claim 1, wherein said physiological monitor comprises an oximeter, and wherein said system is configured for computing and displaying the time variability of a subject's blood oxygen level.

²⁰
Claim ~~74~~ (previously presented): The exercise monitoring system of claim ~~18~~,²⁹ wherein said electronic positioning device comprises a GPS device.

Claim 75 (canceled)

³¹
Claim ~~76~~ (previously presented): The exercise monitoring system of claim ~~74~~,³⁰ wherein said data acquisition unit further comprises a support member, and said GPS device is removably secured to said support member.

³²
Claim ~~77~~ (new): The exercise monitoring system of claim ~~18~~,²⁹ wherein said physiological monitor comprises a heart rate monitor configured to be worn about a subject's chest and to wirelessly transmit data indicative of a subject's heart rate to said display unit.

Remarks

In the Notice of Allowance, claims 1-5, 7-12, 14-18, 60, 62-74 and 76 were allowed. In the amendments presented above, independent Claim 18 has been amended to specify that the exercise monitoring system further includes a physiological monitor, and that the display system simultaneously displays data provided by the electronic positioning device and the physiological monitor. Support for the addition of a physiological monitor can be found throughout the specification as originally filed (e.g., claim 1 as originally filed). Support for the amendment concerning the simultaneous display of data from the electronic positioning device and the physiological monitor can be found, for example, at page 40, lines 7-16, at page 24, lines 1-8, and at Fig. 19 of the specification as originally filed.

Newly added claim 77 depends from claim 18, and further specifies that the physiological monitor comprises a heart rate monitor configured to be worn about a subject's chest and to wirelessly transmit data indicative of a subject's heart rate to the display unit. Support for this new claim can be found, for example, at Fig. 15, and at page 28, line 22, through page 29, line 20, of the specification as originally filed.

The above claim amendments are presented in order to further distinguish these claims from the prior art and to facilitate enforcement of the same. Applicants recently learned that a third party has introduced a product believed to infringe one or more of the previously-allowed claims. The proposed amendments do not require an additional search or examination, since previously-allowed claim 18 is merely being narrowed in scope and newly-added claim 77 depends from previously-allowed claim 18 (and is therefore narrower than previously-allowed claim 18).

For the reasons stated above, applicants request that the Examiner enter the amendments presented herein.

OCT. 24. 2003 3:30PM

NO. 0173 P. 12

Respectfully submitted,

By

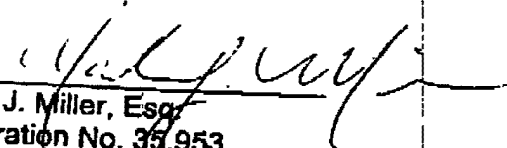
Martin J. Miller, Esq.
Registration No. 35,953
Attorney for Applicant(s)
DINSMORE & SHOHL LLP
1900 Chemed Center
255 East Fifth Street
Cincinnati, Ohio 45202
(513) 977-8565

941993.01

OCT. 24. 2003 3:27PM

DINSMORE
& SHOHL LLP

NO. 0173 P. 1

FACSIMILE TRANSMITTAL

October 24, 2003

from **MARTIN J. MILLER, ESQ.**

Direct: 513-977-8565 / Fax: 513-977-8141 / martin.miller@dinslaw.com

To: Mr. Larry Schwartz
Firm: U.S. Patent and Trademark Office
Fax Number: 703-872-9301
Client Number: 24278-1
Pages: 13
(including cover)
Comments: Re: U.S.S.N. 09/436515

RECEIVED
OCT 24 2003 3 28
Group 3700

Mr. Schwartz,

Per your discussion with Laurie Shirk today, transmitted herewith is a true copy of papers submitted on September 18, 2003. Receipt by the U.S. Patent Office is evidenced by the stamped postcard dated September 22, 2003.

As the issue fee is due on October 29, 2003, your assistance in expediting the processing of the amendment will be appreciated. If you have any questions, please contact me.

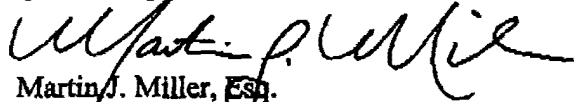
Martin J. Miller, Esq.
Reg. No. 35,953

If there are any problems in receiving this transmission, please call the fax room at (513) 977-8483 immediately. Thank you.

Notice

This message is intended only for the use of the individuals or entity to which it is addressed and may contain information that is privileged, confidential, and exempt from disclosure under applicable law. If the reader of this notice is not the intended recipient or the employee or agent responsible for delivering this message to the intended recipient, you are hereby notified that any dissemination, distribution or copying of this communication is strictly prohibited. If you have received this notice in error, please notify us immediately by telephone and return these papers to us at the address below via first class mail.

Cincinnati • 1900 Chemed Center • 255 East Fifth Street • Cincinnati, OH 45202 • Phone: (513) 977-8200

Received from < > at 10/24/03 3:28:33 PM [Eastern Daylight Time]

IPR2018-00294
Apple Inc. EX1003 Page 25

Serial No. 09/436,515
Inventor: Jack B. Stubbs et al.
Title: Exercise Monitoring System and Methods
Enclosures: Amendment Transmittal; Amendment and
Response under 37 CFR § 1.312; Change of Correspondence
Address Form; and Return Receipt Postcard

Martin J. Miller 24278-1 September 18, 2003

Please place the official stamp of the Patent and Trademark Office on this card and return it to us for our files to constitute an acknowledgement by the PTO of receipt on the date stamped of the above identified paper.

Serial No. 09/436,515
Inventor: Jack B. Stubbs et al.
Title: Exercise Monitoring System and Methods
Enclosures: Amendment Transmittal; Amendment and
Response under 37 CFR § 1.312; Change of Correspondence
Address Form; and Return Receipt Postcard

Martin J. Miller 24278-1 September 18, 2003



Please place the official stamp of the Patent and Trademark Office on this card and return it to us for our files to constitute an acknowledgement by the PTO of receipt on the date stamped of the above identified paper.

Docket No: 24278-1

PATENT

CERTIFICATE OF MAILING

I hereby certify that this paper is being deposited with the United States Postal Service with sufficient postage as first class mail in an envelope addressed to: Mail Stop Non-Fee Amendment; Commissioner for Patents; P.O. Box 1450; Alexandria, VA 22313-1450 on September 18, 2003.

Stephanie Berlepsch

 Stephanie Berlepsch

IN THE UNITED STATES PATENT & TRADEMARK OFFICE

Applicant: Jack B. Stubbs et al. :
 Serial No.: 09/436,515 : Group Art Unit: 3764
 Filed: November 9, 1999 : Examiner: G. E. Richman
 For: Exercise Monitoring System and Methods

Mail Stop Non-Fee Amendment
 Commissioner for Patents
 P.O. Box 1450
 Alexandria, VA 22313-1450

Dear Sir:

Transmitted herewith is an Amendment in the above-identified application.

- additional fee is required.
- also attached: Change of Correspondence Address Form and Return Receipt Postcard

The fee has been calculated as shown below:

	NO. OF CLAIMS	HIGHEST PREVIOUS PAID FOR	EXTRA CLAIMS	RATE	FEE
Total Claims	31	57	0	x \$9 =	\$
Independent Claims	2	9	0	x \$42 =	\$
If multiple claims newly presented, add \$135.00					---
Month Extension Fee					\$
Information Disclosure Statement					\$000.00
TOTAL FEE DUE					\$

- A check in the amount of \$ is enclosed.
- Please charge my Deposit Account No. 04-1133 in the amount of \$.
- The Commissioner is hereby authorized to charge payment of any additional fees associated with this communication or credit any overpayment, to Deposit Account No. 04-1133, including any filing fees under 37 CFR 1.16 for presentation of extra claims and any patent application processing fees under 37 CFR 1.17.

OCT. 24. 2003 3:28PM

Respectfully submitted,

By:

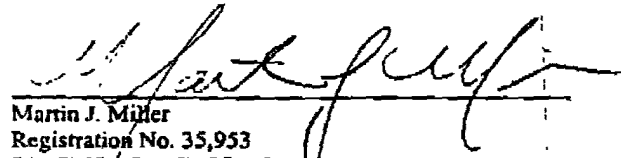

Martin J. Miller
Registration No. 35,953
DINSMORE & SHOHL LLP
1900 Chemed Center
255 East Fifth Street
Cincinnati, Ohio 45202
(513) 977-8565
Date: September 18, 2003

943305_1

OCT. 24. 2003 3:30PM

NO. 0173 P. 13

Handwritten initials and numbers

PTO/SB/122 (10-01)

Approved for use through 10/31/2002. OMB 0651-0035

U.S. Patent and Trademark Office: U.S. DEPARTMENT OF COMMERCE

Under the Paperwork Reduction Act of 1995, no persons are required to respond to a collection of information unless it displays a valid OMB control number.

CHANGE OF CORRESPONDENCE ADDRESS Application Address to: Assistant Commissioner for Patents Washington, D.C. 20231	Application Number	09/436,515
	Filing Date	November 9, 1999
	First Named Inventor	Jack B. Stubbs
	Art Unit	3764
	Examiner Name	G. E. Richman
	Attorney Docket Number	24278-1

Please change the Correspondence Address for the above-identified application to:

Customer Number →  24256
 Type Customer Number here PATENT TRADEMARK OFFICE

OR

Firm or Individual Name			
Address			
Address			
City	State	ZIP	
Country			
Telephone	Fax		

This form cannot be used to change the data associated with a Customer Number. To change the data associated with an existing Customer Number use "Request for Customer Number Data Change" (PTO/SB/124).

I am the:

Applicant/Inventor.

Assignee of record of the entire interest.
Statement under 37 CFR 3.73(b) is enclosed. (Form PTO/SB/96).

Attorney or Agent of record.

Registered practitioner named in the application transmittal letter in an application without an executed oath or declaration. See 37 CFR 1.33(a)(1). Registration Number _____

RECEIVED
OCT 24 2003
Group 3700

Typed or Printed Name: Martin J. Miller, Reg. No. 35,953

Signature: *[Handwritten Signature]*

Date: September 18, 2003

NOTE: Signatures of all the inventors or assignees of record of the entire interest or their representative(s) are required. Submit multiple forms if more than one signature is required, see below*. *Total of 1 forms are submitted.

Burden Hour Statement: This form is estimated to take 3 minutes to complete. Time will vary depending upon the needs of the individual case. Any comments on the amount of time you are required to complete this form should be sent to the Chief Information Officer, U.S. Patent and Trademark Office, Washington, DC 20231. DO NOT SEND FEES OR COMPLETED FORMS TO THIS ADDRESS. SEND TO: Assistant Commissioner for Patents, Washington, DC 20231.

Received from < > at 10/24/03 3:28:33 PM [Eastern Daylight Time]

B



PATENT

Docket No: 24278-1

CERTIFICATE OF MAILING

I hereby certify that this paper is being deposited with the United States Postal Service with sufficient postage as first class mail in an envelope addressed to: Mail Stop Non-Fee Amendment; Commissioner for Patents; P.O. Box 1450; Alexandria, VA 22313-1450 on September 18, 2003.

Stephanle Berlepsch
Stephanle Berlepsch

IN THE UNITED STATES PATENT & TRADEMARK OFFICE

Applicant: Jack B. Stubbs et al. :
Serial No.: 09/436,515 : Group Art Unit: 3764
Filed: November 9, 1999 : Examiner: G. E. Richman
For: Exercise Monitoring System and Methods

Mail Stop Non-Fee Amendment
Commissioner for Patents
P.O. Box 1450
Alexandria, VA 22313-1450

Dear Sir:

Transmitted herewith is an Amendment in the above-identified application.

- additional fee is required.
- also attached: Change of Correspondence Address Form and Return Receipt Postcard

The fee has been calculated as shown below:

	NO. OF CLAIMS	HIGHEST PREVIOUS PAID FOR	EXTRA CLAIMS	RATE	FEE
Total Claims	31	57	0	x \$9 =	\$
Independent Claims	2	9	0	x \$42 =	\$
If multiple claims newly presented, add \$135.00					-----
Month Extension Fee					\$
Information Disclosure Statement					\$000.00
TOTAL FEE DUE					\$

- A check in the amount of \$ is enclosed.
- Please charge my Deposit Account No. 04-1133 in the amount of \$.
- The Commissioner is hereby authorized to charge payment of any additional fees associated with this communication or credit any overpayment, to Deposit Account No. 04-1133, including any filing fees under 37 CFR 1.16 for presentation of extra claims and any patent application processing fees under 37 CFR 1.17.

Respectfully submitted,

By:

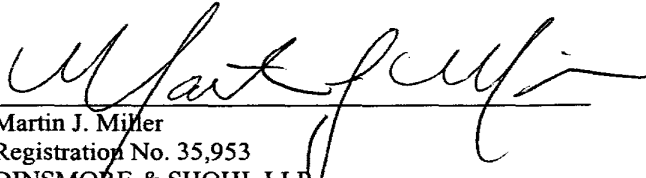

Martin J. Miller
Registration No. 35,953
DINSMORE & SHOHL LLP
1900 Chemed Center
255 East Fifth Street
Cincinnati, Ohio 45202
(513) 977-8565
Date: September 18, 2003

943305_1



Docket No: 24278-1

PATENT

CERTIFICATE OF MAILING

I hereby certify that this paper is being deposited with the United States Postal Service with sufficient postage as first class mail in an envelope addressed to: Mail Stop Non-Fee Amendment; Commissioner for Patents; P.O. Box 1450; Alexandria, VA 22313-1450 on September 18, 2003.

Stephanie Berlepsch
Stephanie Berlepsch

IN THE UNITED STATES PATENT & TRADEMARK OFFICE

Applicant(s): Jack B. Stubbs, et al.	:	Paper No.:
	:	
Serial No.: 09/436,515	:	Group Art Unit: 3764
	:	
Filed: November 9, 1999	:	Examiner: G. E. Richman
	:	
For: Exercise Monitoring System and Methods		

AMENDMENT UNDER 37 CFR §1.312

Mail Stop Non-Fee Amendment
Commissioner for Patents
P.O. Box 1450
Alexandria, VA 22313-1450

Dear Sir:

Pursuant to 37 CFR § 1.312 and MPEP § 714.16, Applicant requests that the above application be amended as follows:

Amendments to the Claims are reflected in the listing of claims which begins on page 2 of this paper.

Remarks begin on page 8 of this paper.

Amendments to the Claims:

This listing of claims will replace all prior versions, and listings, of claims in the application.

Claim 1 (previously presented): An exercise monitoring system, comprising:

- (a) a data acquisition unit comprising an electronic positioning device and a physiological monitor, said data acquisition unit configured to be worn by a subject performing a physical activity; and
- (b) a display unit configured for displaying real-time data provided by said electronic positioning device and said physiological monitor, said display unit separate from said data acquisition unit;

wherein said display unit is configured to be worn by the subject, worn by someone other than the subject, or attached to an apparatus associated with the physical activity being performed by the subject so as to be visible to the subject while performing the physical activity, and further wherein said system is configured such that said display unit displays real-time data comprising at least one of a subject's location, altitude, velocity, pace, and distance traveled.

Claim 2 (original): The exercise monitoring system of claim 1, wherein said electronic positioning device is configured to receive electromagnetic signals from three or more sources so that said monitoring system can determine at least one of a subject's location, altitude, velocity, pace, and distance traveled.

Claim 3 (previously presented): The system of claim 1, wherein said electronic positioning device comprises a GPS device.

Claim 4 (original): The system of claim 1, wherein said physiological monitor is chosen from the group consisting of: an oximeter and a heart rate monitor.

Claim 5 (original): The system of claim 4, wherein said electronic positioning device comprises a GPS device.

Claim 6 (canceled)

Claim 7 (previously presented): The system of claim 1, wherein said electronic positioning device comprises a GPS device, and further wherein said data acquisition unit further comprises a support member, and said GPS device and said physiological monitor are provided on said support member.

Claim 8 (original): The system of claim 7, wherein said GPS device and said physiological monitor are removably secured to said support member.

Claim 9 (previously presented): The system of claim 1, wherein said data acquisition unit is configured to be worn about a human user's waist.

Claim 10 (previously presented): The system of claim 1, wherein said data acquisition unit is configured to be worn about a human user's chest.

Claim 11 (original): The system of claim 1, wherein said display unit is configured to be worn about a human user's wrist.

Claim 12 (original): The system of claim 1, wherein said display unit is configured to be mounted to a bicycle.

Claim13 (canceled)

Claim 14 (original): The system of claim 1, wherein said physiological monitor includes a probe configured for acquiring physiological data from a user.

Claim 15 (original): The system of claim 4, wherein said physiological monitor comprises an oximeter.

Claim 16 (original): The system of claim 4, wherein said physiological monitor comprises a heart rate monitor.

Claim 17 (original): The system of claim 1, wherein said system further comprises an alarm which is activated when data provided by at least one of said electronic

positioning device and said physiological monitor does not meet a predetermined target.

Claim 18 (currently amended): An exercise monitoring system, comprising:

- (a) an electronic positioning device configured to receive electromagnetic signals from three or more sources so that said monitoring system can determine at least one of a subject's velocity or pace, wherein said electronic positioning device is provided as part of a data acquisition unit;
- (b) a physiological monitor;
- ~~(b)~~(c) a display unit configured to be worn by a user and for simultaneously displaying real-time data provided by said electronic positioning device and said physiological monitor, wherein said display unit is separate from said electronic positioning device; and
- ~~(c)~~(d) an alarm, wherein said alarm is activated when a subject's velocity or pace does not meet a predetermined target.

Claims 19-59 (canceled)

Claim 60 (previously presented): The exercise monitoring system of claim 1, wherein said display unit comprises a heads-up type display unit configured to display said data by projecting the data onto glasses, goggles or a visor, or by projecting the data onto a display screen positioned such that the data will be visible to a user.

Claim 61 (canceled)

Claim 62 (previously presented): The exercise monitoring system of claim 1, wherein said system is configured such that the display unit simultaneously displays: at least one of a subject's velocity, pace and distance traveled; and physiological data provided by said physiological monitor.

Claim 63 (previously presented): The exercise monitoring system of claim 1, wherein said system further comprises at least one memory, and at least one

processor for processing acquired data in accordance with instructions stored in said at least one memory.

Claim 64 (previously presented): The exercise monitoring system of claim 63, wherein said data acquisition unit includes memory, and at least one processor for processing acquired data in accordance with instructions stored in said memory of the data acquisition unit, and further wherein said display unit includes memory, and at least one processor for processing acquired data in accordance with instructions stored in said memory of the display unit.

Claim 65 (previously presented): The exercise monitoring system of claim 63, wherein said at least one memory is configured for storing acquired data for later retrieval.

Claim 66 (previously presented): The exercise monitoring system of claim 1, wherein said display unit is configured for communication with said data acquisition unit via a wired or wireless link, such that data indicative of at least one of a subject's velocity or pace can be transmitted to said display unit.

Claim 67 (previously presented): The exercise monitoring system of claim 66, wherein said display unit is configured for communication with said data acquisition unit via radio waves.

Claim 68 (previously presented): The exercise monitoring system of claim 1, wherein said system is configured for computing a subject's workload based on the subject's velocity and altitude changes, and displaying the computed workload.

Claim 69 (previously presented): The exercise monitoring system of claim 68, wherein said system is configured for the input of a subject's weight, and said system is configured for computing a subject's workload based on the subject's velocity, altitude changes and inputted weight.

Claim 70 (previously presented): The exercise monitoring system of claim 1, wherein said system is configured for electrical communication with an external computer such that acquired data may be stored in the computer.

Claim 71 (previously presented): The exercise monitoring system of claim 17, wherein said physiological monitor comprises an oximeter, and wherein said system is configured such that said alarm is activated when a subject's blood oxygen level does not meet a predetermined target.

Claim 72 (previously presented): The exercise monitoring system of claim 71, wherein said system is configured such that a plurality of predetermined targets for blood oxygen level may be input into said system.

Claim 73 (previously presented): The exercise monitoring system of claim 1, wherein said physiological monitor comprises an oximeter, and wherein said system is configured for computing and displaying the time variability of a subject's blood oxygen level.

Claim 74 (previously presented): The exercise monitoring system of claim 18, wherein said electronic positioning device comprises a GPS device.

Claim 75 (canceled)

Claim 76 (previously presented): The exercise monitoring system of claim 74, wherein said data acquisition unit further comprises a support member, and said GPS device is removably secured to said support member.

Claim 77 (new): The exercise monitoring system of claim 18, wherein said physiological monitor comprises a heart rate monitor configured to be worn about a subject's chest and to wirelessly transmit data indicative of a subject's heart rate to said display unit.

Remarks

In the Notice of Allowance, claims 1-5, 7-12, 14-18, 60, 62-74 and 76 were allowed. In the amendments presented above, independent Claim 18 has been amended to specify that the exercise monitoring system further includes a physiological monitor, and that the display system simultaneously displays data provided by the electronic positioning device and the physiological monitor. Support for the addition of a physiological monitor can be found throughout the specification as originally filed (e.g., claim 1 as originally filed). Support for the amendment concerning the simultaneous display of data from the electronic positioning device and the physiological monitor can be found, for example, at page 40, lines 7-16, at page 24, lines 1-8, and at Fig. 19 of the specification as originally filed.

Newly added claim 77 depends from claim 18, and further specifies that the physiological monitor comprises a heart rate monitor configured to be worn about a subject's chest and to wirelessly transmit data indicative of a subject's heart rate to the display unit. Support for this new claim can be found, for example, at Fig. 15, and at page 28, line 22, through page 29, line 20, of the specification as originally filed.

The above claim amendments are presented in order to further distinguish these claims from the prior art and to facilitate enforcement of the same. Applicants recently learned that a third party has introduced a product believed to infringe one or more of the previously-allowed claims. The proposed amendments do not require an additional search or examination, since previously-allowed claim 18 is merely being narrowed in scope and newly-added claim 77 depends from previously-allowed claim 18 (and is therefore narrower than previously-allowed claim 18).

For the reasons stated above, applicants request that the Examiner enter the amendments presented herein.

Respectfully submitted,

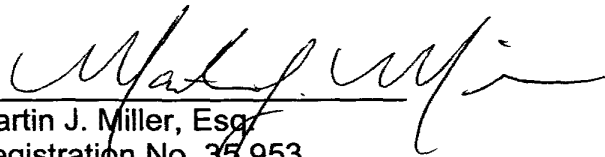
By 

Martin J. Miller, Esq.
Registration No. 35,953
Attorney for Applicant(s)
DINSMORE & SHOHL LLP
1900 Chemed Center
255 East Fifth Street
Cincinnati, Ohio 45202
(513) 977-8565

941993.01



Under the Paperwork Reduction Act of 1995, no persons are required to respond to a collection of information unless it displays a valid OMB control number.

CHANGE OF CORRESPONDENCE ADDRESS Application Address to: Assistant Commissioner for Patents Washington, D.C. 20231	Application Number	09/436,515
	Filing Date	November 9, 1999
	First Named Inventor	Jack B. Stubbs
	Art Unit	3764
	Examiner Name	G. E. Richman
	Attorney Docket Number	24278-1

Please change the Correspondence Address for the above-identified application to:

Customer Number

24256

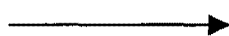

24256

PATENT TRADEMARK OFFICE

Type Customer Number here

OR

Firm or Individual Name				
Address				
Address				
City		State		ZIP
Country				
Telephone		Fax		

This form cannot be used to change the data associated with a Customer Number. To change the data associated with an existing Customer Number use "Request for Customer Number Data Change" (PTO/SB/124).

I am the:

Applicant/Inventor.

Assignee of record of the entire interest.
 Statement under 37 CFR 3.73(b) is enclosed. (Form PTO/SB/96).

Attorney or Agent of record.

Registered practitioner named in the application transmittal letter in an application without an executed oath or declaration. See 37 CFR 1.33(a)(1). Registration Number _____

Typed or Printed Name Martin J. Miller, Reg. No. 35,953

Signature

Date September 18, 2003

NOTE: Signatures of all the inventors or assignees of record of the entire interest or their representative(s) are required. Submit multiple forms if more than one signature is required, see below*.

*Total of 1 forms are submitted.

Burden Hour Statement: This form is estimated to take 3 minutes to complete. Time will vary depending upon the needs of the individual case. Any comments on the amount of time you are required to complete this form should be sent to the Chief Information Officer, U.S. Patent and Trademark Office, Washington, DC 20231. DO NOT SEND FEES OR COMPLETED FORMS TO THIS ADDRESS. SEND TO: Assistant Commissioner for Patents, Washington, DC 20231.



CH

NOTICE OF ALLOWANCE AND FEE(S) DUE

7590 07/29/2003
DINSMORE AND SHOHL LLP
1900 CHEMED CENTER
255 EAST FIFTH STREET
CINCINNATI, OH 45202

EXAMINER

RICHMAN, GLENN E

ART UNIT CLASS-SUBCLASS
3764 482-008000

DATE MAILED: 07/29/2003

APPLICATION NO.	FILING DATE	FIRST NAMED INVENTOR	ATTORNEY DOCKET NO.	CONFIRMATION NO.
09/436,515	11/09/1999	JACK B. STUBBS	24278-1	6756

TITLE OF INVENTION: EXERCISE MONITORING SYSTEM AND METHODS

APPLN. TYPE	SMALL ENTITY	ISSUE FEE	PUBLICATION FEE	TOTAL FEE(S) DUE	DATE DUE
nonprovisional	YES	\$650	\$0	\$650	10/29/2003

THE APPLICATION IDENTIFIED ABOVE HAS BEEN EXAMINED AND IS ALLOWED FOR ISSUANCE AS A PATENT. **PROSECUTION ON THE MERITS IS CLOSED.** THIS NOTICE OF ALLOWANCE IS NOT A GRANT OF PATENT RIGHTS. THIS APPLICATION IS SUBJECT TO WITHDRAWAL FROM ISSUE AT THE INITIATIVE OF THE OFFICE OR UPON PETITION BY THE APPLICANT. SEE 37 CFR 1.313 AND MPEP 1308.

THE ISSUE FEE AND PUBLICATION FEE (IF REQUIRED) MUST BE PAID WITHIN **THREE MONTHS** FROM THE MAILING DATE OF THIS NOTICE OR THIS APPLICATION SHALL BE REGARDED AS ABANDONED. **THIS STATUTORY PERIOD CANNOT BE EXTENDED.** SEE 35 U.S.C. 151. THE ISSUE FEE DUE INDICATED ABOVE REFLECTS A CREDIT FOR ANY PREVIOUSLY PAID ISSUE FEE APPLIED IN THIS APPLICATION. THE PTOL-85B (OR AN EQUIVALENT) MUST BE RETURNED WITHIN THIS PERIOD EVEN IF NO FEE IS DUE OR THE APPLICATION WILL BE REGARDED AS ABANDONED.

HOW TO REPLY TO THIS NOTICE:

I. Review the SMALL ENTITY status shown above.

If the SMALL ENTITY is shown as YES, verify your current SMALL ENTITY status:

- A. If the status is the same, pay the TOTAL FEE(S) DUE shown above.
- B. If the status is changed, pay the PUBLICATION FEE (if required) and twice the amount of the ISSUE FEE shown above and notify the United States Patent and Trademark Office of the change in status, or

If the SMALL ENTITY is shown as NO:

- A. Pay TOTAL FEE(S) DUE shown above, or
- B. If applicant claimed SMALL ENTITY status before, or is now claiming SMALL ENTITY status, check the box below and enclose the PUBLICATION FEE and 1/2 the ISSUE FEE shown above.
 - Applicant claims SMALL ENTITY status. See 37 CFR 1.27.

II. PART B - FEE(S) TRANSMITTAL should be completed and returned to the United States Patent and Trademark Office (USPTO) with your ISSUE FEE and PUBLICATION FEE (if required). Even if the fee(s) have already been paid, Part B - Fee(s) Transmittal should be completed and returned. If you are charging the fee(s) to your deposit account, section "4b" of Part B - Fee(s) Transmittal should be completed and an extra copy of the form should be submitted.

III. All communications regarding this application must give the application number. Please direct all communications prior to issuance to Box ISSUE FEE unless advised to the contrary.

IMPORTANT REMINDER: Utility patents issuing on applications filed on or after Dec. 12, 1980 may require payment of maintenance fees. It is patentee's responsibility to ensure timely payment of maintenance fees when due.

PART B - FEE(S) TRANSMITTAL

Complete and send this form, together with applicable fee(s), to: **Mail** Mail Stop ISSUE FEE
Commissioner for Patents
Alexandria, Virginia 22313-1450
Fax (703)746-4000

INSTRUCTIONS: This form should be used for transmitting the ISSUE FEE and PUBLICATION FEE (if required). Blocks 1 through 4 should be completed where appropriate. All further correspondence including the Patent, advance orders and notification of maintenance fees will be mailed to the current correspondence address as indicated unless corrected below or directed otherwise in Block 1, by (a) specifying a new correspondence address; and/or (b) indicating a separate "FEE ADDRESS" for maintenance fee notifications.

CURRENT CORRESPONDENCE ADDRESS (Note: Legibly mark-up with any corrections or use Block 1)

7590 07/29/2003

DINSMORE AND SHOHL LLP
 1900 CHEMED CENTER
 255 EAST FIFTH STREET
 CINCINNATI, OH 45202

Note: A certificate of mailing can only be used for domestic mailings of the Fee(s) Transmittal. This certificate cannot be used for any other accompanying papers. Each additional paper, such as an assignment or formal drawing, must have its own certificate of mailing or transmission.

Certificate of Mailing or Transmission

I hereby certify that this Fee(s) Transmittal is being deposited with the United States Postal Service with sufficient postage for first class mail in an envelope addressed to the Box Issue Fee address above, or being facsimile transmitted to the USPTO, on the date indicated below.

(Depositor's name)
(Signature)
(Date)

APPLICATION NO.	FILING DATE	FIRST NAMED INVENTOR	ATTORNEY DOCKET NO.	CONFIRMATION NO.
09/436,515	11/09/1999	JACK B. STUBBS	24278-1	6756

TITLE OF INVENTION: EXERCISE MONITORING SYSTEM AND METHODS

APPLN. TYPE	SMALL ENTITY	ISSUE FEE	PUBLICATION FEE	TOTAL FEE(S) DUE	DATE DUE
nonprovisional	YES	\$650	\$0	\$650	10/29/2003

EXAMINER	ART UNIT	CLASS-SUBCLASS
RICHMAN, GLENN E	3764	482-008000

1. Change of correspondence address or indication of "Fee Address" (37 CFR 1.363).

- Change of correspondence address (or Change of Correspondence Address form PTO/SB/122) attached.
- "Fee Address" indication (or "Fee Address" Indication form PTO/SB/47; Rev 03-02 or more recent) attached. **Use of a Customer Number is required.**

2. For printing on the patent front page, list (1) the names of up to 3 registered patent attorneys or agents OR, alternatively, (2) the name of a single firm (having as a member a registered attorney or agent) and the names of up to 2 registered patent attorneys or agents. If no name is listed, no name will be printed.

1 _____
 2 _____
 3 _____

3. ASSIGNEE NAME AND RESIDENCE DATA TO BE PRINTED ON THE PATENT (print or type)

PLEASE NOTE: Unless an assignee is identified below, no assignee data will appear on the patent. Inclusion of assignee data is only appropriate when an assignment has been previously submitted to the USPTO or is being submitted under separate cover. Completion of this form is NOT a substitute for filing an assignment.

(A) NAME OF ASSIGNEE _____ (B) RESIDENCE: (CITY and STATE OR COUNTRY) _____

Please check the appropriate assignee category or categories (will not be printed on the patent) individual corporation or other private group entity government

4a. The following fee(s) are enclosed:

- Issue Fee
- Publication Fee
- Advance Order - # of Copies _____

4b. Payment of Fee(s):

- A check in the amount of the fee(s) is enclosed.
- Payment by credit card. Form PTO-2038 is attached.
- The Commissioner is hereby authorized by charge the required fee(s), or credit any overpayment, to Deposit Account Number _____ (enclose an extra copy of this form).

Commissioner for Patents is requested to apply the Issue Fee and Publication Fee (if any) or to re-apply any previously paid issue fee to the application identified above.

(Authorized Signature) _____ NOTE: The Issue Fee and Publication Fee (if required) will not be accepted from anyone other than the applicant; a registered attorney or agent; or the assignee or other party in interest as shown by the records of the United States Patent and Trademark Office. This collection of information is required by 37 CFR 1.311. The information is required to obtain or retain a benefit by the public which is to file (and by the USPTO to process) an application. Confidentiality is governed by 35 U.S.C. 122 and 37 CFR 1.14. This collection is estimated to take 12 minutes to complete, including gathering, preparing, and submitting the completed application form to the USPTO. Time will vary depending upon the individual case. Any comments on the amount of time you require to complete this form and/or suggestions for reducing this burden, should be sent to the Chief Information Officer, U.S. Patent and Trademark Office, U.S. Department of Commerce, Alexandria, Virginia 22313-1450. DO NOT SEND FEES OR COMPLETED FORMS TO THIS ADDRESS. SEND TO: Commissioner for Patents, Alexandria, Virginia 22313-1450. Under the Paperwork Reduction Act of 1995, no persons are required to respond to a collection of information unless it displays a valid OMB control number.	(Date) _____
---------------------------------------------------------------------------------------------------------------------------------------------------------------------------------------------------------------------------------------------------------------------------------------------------------------------------------------------------------------------------------------------------------------------------------------------------------------------------------------------------------------------------------------------------------------------------------------------------------------------------------------------------------------------------------------------------------------------------------------------------------------------------------------------------------------------------------------------------------------------------------------------------------------------------------------------------------------------------------------------------------------------------------------------------------------------------------------------------------------------------------------------------------------------------------------------------------------------------------------------------------------------------------------------------------------------------------------------------------------------	--------------

TRANSMIT THIS FORM WITH FEE(S)



UNITED STATES PATENT AND TRADEMARK OFFICE

UNITED STATES DEPARTMENT OF COMMERCE
United States Patent and Trademark Office
Address: COMMISSIONER FOR PATENTS
P.O. Box 1450
Alexandria, Virginia 22313-1450
www.uspto.gov

Table with 5 columns: APPLICATION NO., FILING DATE, FIRST NAMED INVENTOR, ATTORNEY DOCKET NO., CONFIRMATION NO.
09/436,515 11/09/1999 JACK B. STUBBS 24278-1 6756

7590 07/29/2003
DINSMORE AND SHOHL LLP
1900 CHEMED CENTER
255 EAST FIFTH STREET
CINCINNATI, OH 45202

Table with 2 columns: EXAMINER, ART UNIT, PAPER NUMBER
EXAMINER: RICHMAN, GLENN E
ART UNIT: 3764
PAPER NUMBER: 18

DATE MAILED: 07/29/2003

Determination of Patent Term Extension under 35 U.S.C. 154 (b)
(application filed after June 7, 1995 but prior to May 29, 2000)

The patent term extension is 0 days. Any patent to issue from the above identified application will include an indication of the 0 day extension on the front page.

If a continued prosecution application (CPA) was filed in the above-identified application, the filing date that determines patent term extension is the filing date of the most recent CPA.

Applicant will be able to obtain more detailed information by accessing the Patent Application Information Retrieval (PAIR) system. (http://pair.uspto.gov)

Any questions regarding the patent term extension or adjustment determination should be directed to the Office of Patent Legal Administration at (703)305-1383.



UNITED STATES PATENT AND TRADEMARK OFFICE

UNITED STATES DEPARTMENT OF COMMERCE
United States Patent and Trademark Office
Address: COMMISSIONER FOR PATENTS
P.O. Box 1450
Alexandria, Virginia 22313-1450
www.uspto.gov

Table with 5 columns: APPLICATION NO., FILING DATE, FIRST NAMED INVENTOR, ATTORNEY DOCKET NO., CONFIRMATION NO.
09/436,515 11/09/1999 JACK B. STUBBS 24278-1 6756

7590 07/29/2003
DINSMORE AND SHOHL LLP
1900 CHEMED CENTER
255 EAST FIFTH STREET
CINCINNATI, OH 45202

EXAMINER

RICHMAN, GLENN E

ART UNIT PAPER NUMBER

3764

DATE MAILED: 07/29/2003

Notice of Fee Increase on January 1, 2003

If a reply to a "Notice of Allowance and Fee(s) Due" is filed in the Office on or after January 1, 2003, then the amount due will be higher than that set forth in the "Notice of Allowance and Fee(s) Due" since there will be an increase in fees effective on January 1, 2003. See Revision of Patent and Trademark Fees for Fiscal Year 2003; Final Rule, 67 Fed. Reg. 70847, 70849 (November 27, 2002).

The current fee schedule is accessible from: http://www.uspto.gov/main/howtofees.htm.

If the issue fee paid is the amount shown on the "Notice of Allowance and Fee(s) Due," but not the correct amount in view of the fee increase, a "Notice to Pay Balance of Issue Fee" will be mailed to applicant. In order to avoid processing delays associated with mailing of a "Notice to Pay Balance of Issue Fee," if the response to the Notice of Allowance and Fee(s) due form is to be filed on or after January 1, 2003 (or mailed with a certificate of mailing on or after January 1, 2003), the issue fee paid should be the fee that is required at the time the fee is paid. If the issue fee was previously paid, and the response to the "Notice of Allowance and Fee(s) Due" includes a request to apply a previously-paid issue fee to the issue fee now due, then the difference between the issue fee amount at the time the response is filed and the previously paid issue fee should be paid. See Manual of Patent Examining Procedure, Section 1308.01 (Eighth Edition, August 2001).

Questions relating to issue and publication fee payments should be directed to the Customer Service Center of the Office of Patent Publication at (703) 305-8283.

EC

Notice of Allowability

Application No. 09/436,515	Applicant(s) Stubbs et al	
Examiner Glenn Richman	Art Unit 3764	

--The MAILING DATE of this communication appears on the cover sheet with the correspondence address--

All claims being allowable, PROSECUTION ON THE MERITS IS (OR REMAINS) CLOSED in this application. If not included herewith (or previously mailed), a Notice of Allowance (PTOL-85) or other appropriate communication will be mailed in due course. **THIS NOTICE OF ALLOWABILITY IS NOT A GRANT OF PATENT RIGHTS.** This application is subject to withdrawal from issue at the initiative of the Office or upon petition by the applicant. See 37 CFR 1.313 and MPEP 1308.

- 1. This communication is responsive to 7/17/03.
- 2. The allowed claim(s) is/are 1-5, 7-12, 14-18, 60, 62-74, and 76.
- 3. The drawings filed on Nov 9, 1999 are accepted by the Examiner.
- 4. Acknowledgement is made of a claim for foreign priority under 35 U.S.C. § 119(a)-(d).
 - a) All b) Some* c) None of the:
 - 1. Certified copies of the priority documents have been received.
 - 2. Certified copies of the priority documents have been received in Application No. _____.
 - 3. Copies of the certified copies of the priority documents have been received in this national stage application from the International Bureau (PCT Rule 17.2(a)).

*Certified copies not received: _____

- 5. Acknowledgement is made of a claim for domestic priority under 35 U.S.C. § 119(e) (to a provisional application).
 - (a) The translation of the foreign language provisional application has been received.
- 6. Acknowledgement is made of a claim for domestic priority under 35 U.S.C. §§ 120 and/or 121.

Applicant has THREE MONTHS FROM THE "MAILING DATE" of this communication to file a reply complying with the requirements noted below. Failure to timely comply will result in ABANDONMENT of this application. **THIS THREE-MONTH PERIOD IS NOT EXTENDABLE.**

- 7. A SUBSTITUTE OATH OR DECLARATION must be submitted. Note the attached EXAMINER'S AMENDMENT or NOTICE OF INFORMAL PATENT APPLICATION (PTO-152) which gives reason(s) why the oath or declaration is deficient.
- 8. CORRECTED DRAWINGS must be submitted.
 - (a) including changes required by the Notice of Draftsperson's Patent Drawing Review (PTO-948) attached
 - 1) hereto or 2) to Paper No. _____.
 - (b) including changes required by the proposed drawing correction filed _____, which has been approved by the examiner.
 - (c) including changes required by the attached Examiner's Amendment/Comment or in the Office action of Paper No. _____.

Identifying indicia such as the application number (see 37 CFR 1.84(c)) should be written on the drawings in the top margin (not the back) of each sheet. The drawings should be filed as a separate paper with a transmittal letter addressed to the Official Draftsperson.

- 9. DEPOSIT OF and/or INFORMATION about the deposit of BIOLOGICAL MATERIAL must be submitted. Note the attached Examiner's comment regarding REQUIREMENT FOR THE DEPOSIT OF BIOLOGICAL MATERIAL.

Attachment(s)

- 1 Notice of References Cited (PTO-892)
- 2 Notice of Informal Patent Application (PTO-152)
- 3 Notice of Draftsperson's Patent Drawing Review (PTO-948)
- 4 Interview Summary (PTO-413), Paper No. _____
- 5 Information Disclosure Statement(s) (PTO-1449), Paper No(s) 16
- 6 Examiner's Amendment/Comment
- 7 Examiner's Comment Regarding Requirement for Deposit of Biological Material
- 8 Examiner's Statement of Reasons for Allowance
- 9 Other

NICHOLAS D. LUCCHESI
 SUPERVISORY PATENT EXAMINER
 TECHNOLOGY CENTER 3700

GLENN RICHMAN
 PRIMARY EXAMINER
 ART UNIT 3764

OFFICE OF THE COMMISSIONER OF PATENT & TRADEMARK OFFICE
MAY 16 2003

PTO FORM 4/92 Page 1 of 1

FORM PTO - 1449 LIST OF PATENTS AND PUBLICATIONS FOR APPLICANT'S INFORMATION DISCLOSURE STATEMENT	ATTY DOCKET. 24278-1 APPLICANT Stubbs, et al. FILING DATE November 9, 1999 FOR EXERCISE MONITORING SYSTEM AND METHODS	SERIAL NO. 09/436,515 GROUP 3661
----------------------------------------------------------------------------------------------------------------------------------------	----------------------------------------------------------------------------------------------------------------------------------------------------------------------	---------------------------------------------------------

UNITED STATES LETTERS PATENT

	DOCUMENT NUMBER							DATE	NAME	CLASS	SUB CLASS
1	6	1	9	9	5	5	0	Mar. 13, 2001	Wiesmann et al.	—	—

RECEIVED
MAY 23 2003
TECHNOLOGY CENTER

FOREIGN PATENT DOCUMENTS

	DOCUMENT NUMBER							DATE	NAME	CLASS	SUB CLASS

OTHER ART (INCLUDING AUTHOR, TITLE DATE, PERTINENT PAGES, ETC.)

EXAMINER: *Rickmar* DATE CONSIDERED *7/27/03*
 EXAMINER: Initial if reference considered, whether or not citation is in conformance with MPEP 609; Draw line through citation if not in conformance and no considered. Include copy of this form with next communication to applicant.

Docket No: 24278-1

CERTIFICATE OF MAILING

I hereby certify that this paper is being deposited with the United States Postal Service with sufficient postage as first class mail in an envelope addressed to: Mail Stop: Amendment; Commissioner for Patents; P.O. Box 1450; Alexandria, VA 22313-1450 on July 14, 2003.

Martin J. Miller



AM/C
55
PATENT
755B

IN THE UNITED STATES PATENT & TRADEMARK OFFICE

Applicant(s):	Jack B. Stubbs, et al.	:	Paper No.:
Serial No.:	09/436,515	:	Group Art Unit: 3764
Filed:	November 9, 1999	:	Examiner: G. E. Richman
For:	Exercise Monitoring System and Methods		

AMENDMENT

Mail Stop: Amendment
Commissioner for Patents
P.O. Box 1450
Alexandria, VA 22313-1450

RECEIVED
JUL 23 2003
TECHNOLOGY CENTER R3700

Dear Sir:

In response to the Office Action dated February 12, 2003, please amend the present application as follows:

In the Claims:

Please amend claim 1 as follows:

1. (twice amended) An exercise monitoring system, comprising:
 - (a) a data acquisition unit comprising an electronic positioning device and a physiological monitor, said data acquisition unit configured to be worn by a subject performing a physical activity; and

07/21/2003 GGEBREGI 00000038 041133 09436515

01 FC:2252 205.00 DA

C

(b) a display unit configured for displaying real-time data provided by said electronic positioning device and said physiological monitor, said display unit separate from said data acquisition unit;

wherein said display unit is configured to be worn by the subject, worn by someone other than the subject, or attached to an apparatus associated with the physical activity being performed by the subject so as to be visible to the subject while performing the physical activity, and

further wherein said system is configured such that said display unit displays real-time data comprising at least one of a subject's location, altitude, velocity, pace, and distance traveled.

C1
Please amend claim 3 as follows:

C2 3. (amended) The system of claim 1, wherein said electronic positioning device comprises a GPS device.

Please cancel claim 6.

Please amend claim 7 as follows:

C3 67. (amended) The system of claim 1, wherein said electronic positioning device comprises a GPS device, and further wherein said data acquisition unit further comprises a support member, and said GPS device and said physiological monitor are provided on said support member.

Please amend claim 9 as follows:

82 (amended) The system of claim 1, wherein said data acquisition unit is configured to be worn about a human user's waist.

C4 Please amend claim 10 as follows:

970. (amended) The system of claim 1, wherein said data acquisition unit is configured to be worn about a human user's chest.

Please amend claim 18 as follows:

C5 2718. (twice amended) An exercise monitoring system, comprising:

CV
C5

- (a) an electronic positioning device configured to receive electromagnetic signals from three or more sources so that said monitoring system can determine at least one of a subject's velocity or pace, wherein said electronic positioning device is provided as part of a data acquisition unit;
- (b) a display unit configured to be worn by a user and for displaying real-time data provided by said electronic positioning device wherein said display unit is separate from said electronic positioning device; and
- (c) an alarm, wherein said alarm is activated when a subject's velocity or pace does not meet a predetermined target.

Please cancel claim 59.

Please amend claim 60 as follows:

C6

60. (amended) The exercise monitoring system of claim 1, wherein said display unit comprises a heads-up type display unit configured to display said data by projecting the data onto glasses, goggles or a visor, or by projecting the data onto a display screen positioned such that the data will be visible to a user.

Please cancel claim 61.

Please amend claim 62 as follows:

C7

62. (amended) The exercise monitoring system of claim 1, wherein said system is configured such that the display unit simultaneously displays: at least one of a subject's velocity, pace and distance traveled; and physiological data provided by said physiological monitor.

Please amend claim 63 as follows:

63. (amended) The exercise monitoring system of claim 1, wherein said system further comprises at least one memory, and at least one processor for processing acquired data in accordance with instructions stored in said at least one memory.

Please amend claim 66 as follows:

C

22 66. (amended) The exercise monitoring system of claim 1, wherein said display unit is configured for communication with said data acquisition unit via a wired or wireless link, such that data indicative of at least one of a subject's velocity or pace can be transmitted to said display unit.

Please cancel claim 75.

Please amend claim 76 as follows:

3, 76. (amended) The exercise monitoring system of claim 74, wherein said data acquisition unit further comprises a support member, and said GPS device is removably secured to said support member.

REMARKS

In the Office Action dated February 12, 2003, the Examiner has rejected all of the pending claims in the present application. Specifically, the Examiner rejected claims 1, 3-12, 14, 16, 59 and 62-70 under 35 U.S.C. 102(e) as being anticipated by Root et al. Claims 2, 15, 17, 18 and 71-76 were rejected under 35 U.S.C. 103(a) as being obvious in view of Root et al. Finally, claims 60 and 61 were rejected under 35 U.S.C. 103(a) as being obvious over Root in view of Seiple et al. Applicants believe that all of the claims, as amended herein, are novel and non-obvious over the cited art.

Specifically, claim 1 has been amended to require that the electronic positioning device and physiological monitor are provided as a data acquisition unit which is configured to be worn by a subject performing a physical activity. Claim 1 has also been amended to require that the display unit is separate from the data acquisition unit and is configured to display real-time data. Finally, claim 1 now specifies that the display unit is configured to be worn by the subject, worn by someone other than the subject (e.g., a jockey), or attached to an apparatus associated with the physical activity being performed by the subject so as to be visible to the subject (e.g., bicycle handlebars). Claim 1 now includes all of the limitations of previous claims 6 and 61,

hence these claims have been cancelled. Support for the "real-time" limitation can be found in the specification as filed, for example, at page 12, lines 3-5. The dependency of claims 7, 9, 10, 63 and 66 have been amended to reflect the cancellation of claims 6 and 61.

Similarly, independent claim 18 has been amended to specify that the electronic positioning device is provided as part of a data acquisition unit which is separate from the display unit. Claim 18 has also been amended to specify that the display unit is configured to be worn by a user and is configured to display real-time data. Accordingly, claim 75 has been cancelled and the dependency of claim 76 amended. The remaining amendments are stylistic in nature and are not made for any reason pertaining to patentability.

The Root patent describes a monitor for providing an athlete with performance data. In contrast to the structure required by independent claims 1 and 18, as amended herein, however, the monitor described in Root is an unitary structure in which the data acquisition unit and the display screen are provided as a single unit. The Examiner has indicated that Figure 7 of Root discloses a performance monitor in which the display unit is separate from the data acquisition unit. The display unit in Figure 7, however, is a personal computer which obviously cannot be worn by someone or attached to an apparatus associated with physical activity being performed by the subject so as to be visible while the subject performs the physical activity. Furthermore, the personal computer depicted in Fig. 7 of Root cannot be used to display real-time data, as required by claim 1. Rather, the personal computer in Fig. 7 of Root will merely display performance data after the athlete has completed their activity. Thus, claim 1 as amended herein, clearly distinguishes over Root.

Furthermore, Root clearly and unequivocally teaches away from the invention defined by claim 1 herein. Specifically, at column 9, line 67 - column 10, line 6, Root states that the performance monitor described therein "eliminates the exclusive use of large, power-consuming, cumbersome, and visually distracting displays and leaves the athlete free to concentrate his/her exercise, safety, and surroundings." Thus, not only

does Root not contemplate the use of the physically separate display unit configured for displaying real-time data, it clearly teaches away from modifying the disclosed performance monitor to provide such an arrangement. Thus, it would not have been obvious to modify the device taught by Root to provide the exercise monitoring system of claim 1 herein.

Independent claim 18 has been similarly amended, and therefore requires that the electronic positioning device be provided as part of a data acquisition unit which is separate from the display unit and that the display unit is configured to be worn by the user. Claim 18 also requires that the display unit display real-time data acquired by the electronic positioning device. For the reasons stated above with respect to claim 1, claim 18 is patentable over the Root reference, either alone, or in combination with any other cited reference.

For the reasons stated above, applicants specifically request that the Examiner allow all of the pending claims for this application.

Respectfully submitted,

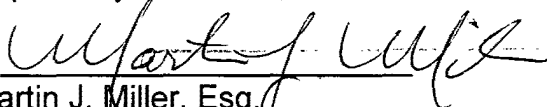
By 

Martin J. Miller, Esq.
Registration No. 35,953
Attorney for Applicant(s)
DINSMORE & SHOHL LLP
1900 Chemed Center
255 East Fifth Street
Cincinnati, Ohio 45202
(513) 977-8565

922574.01

C

VERSION WITH MARKINGS TO SHOW CHANGES MADE

In the Claims:

Claim 1 has been amended as follows:

1. (twice amended) An exercise monitoring system, comprising:
 - (a) a data acquisition unit comprising an electronic positioning device and [;
 - (b)] a physiological monitor, said data acquisition unit configured to be worn by a subject performing a physical activity; and
 - (b[c]) a display unit configured for displaying real-time data provided by said electronic positioning device and said physiological monitor, said display unit separate from said data acquisition unit;

wherein said display unit is configured to be worn by the subject, worn by someone other than the subject, or attached to an apparatus associated with the physical activity being performed by the subject so as to be visible to the subject while performing the physical activity, and

further wherein said system is configured such that said display unit displays real-time data comprising at least one of a subject's location, altitude, velocity, pace, and distance traveled.

Claim 3 has been amended as follows:

3. (amended) The system of claim [2] 1, wherein said electronic positioning device comprises a GPS device.

Claim 6 has been cancelled.

Claim 7 has been amended as follows:

7. (amended) The system of claim [6] 1, wherein said electronic positioning device comprises a GPS device, and further wherein said data acquisition unit further comprises a support member, and said GPS device and said physiological monitor are provided on said support member.

Claim 9 has been amended as follows:

9. (amended) The system of claim [6] 1, wherein said data acquisition unit is configured to be worn about a human user's waist.

Claim 10 has been amended as follows:

10. (amended) The system of claim [6] 1, wherein said data acquisition unit is configured to be worn about a human user's chest.

Claim 18 has been amended as follows:

18. (amended) An exercise monitoring system, comprising:
 - (a) an electronic positioning device configured to receive electromagnetic signals from three or more sources so that said monitoring system can determine at least one of a subject's velocity or pace, wherein said electronic positioning device is provided as part of a data acquisition unit;
 - (b) a display unit configured to be worn by a user and for displaying real-time data provided by said electronic positioning device wherein said display unit is separate from said electronic positioning device; and
 - (c) an alarm, wherein said alarm is activated when a subject's velocity or pace does not meet a predetermined target.

Claim 59 has been cancelled.

Claim 60 has been amended as follows:

60. (amended) The exercise monitoring system of claim [59] 1, wherein said display unit comprises a heads-up type display unit configured to display said data by projecting the data onto glasses, goggles or a visor, or by projecting the data onto a display screen positioned such that the data will be visible to a user.

Claim 61 has been cancelled.

Claim 62 has been amended as follows:

62. (amended) The exercise monitoring system of claim [2] 1, wherein said system is configured such that the display unit simultaneously displays: at least one of a

subject's velocity, pace and distance traveled; and physiological data provided by said physiological monitor.

Claim 63 has been amended as follows:

63. (amended) The exercise monitoring system of claim [6] 1, wherein said system further comprises at least one memory, and at least one processor for processing acquired data in accordance with instructions stored in said at least one memory.

Claim 66 has been amended as follows:

66. (amended) The exercise monitoring system of claim [6] 1, wherein said display unit is configured for communication with said data acquisition unit via a wired or wireless link, such that data indicative of at least one of a subject's velocity or pace can be transmitted to said display unit.

Claim 75 has been cancelled.

Claim 76 has been amended as follows:

76. (amended) The exercise monitoring system of claim [75] 74, wherein said data acquisition unit further comprises a support member, and said GPS device is removably secured to said support member.

3764/1

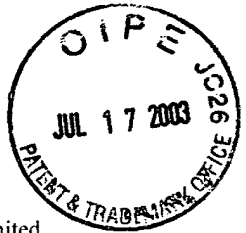

PATENT

Docket No: 24278-1

CERTIFICATE OF MAILING

I hereby certify that this paper is being deposited with the United States Postal Service with sufficient postage as first class mail in an envelope addressed to: Mail Stop: Amendment; Commissioner for Patents; P.O. Box 1450; Alexandria, VA 22313-1450 on July 14, 2003.

Martin J. Miller
Martin J. Miller

IN THE UNITED STATES PATENT & TRADEMARK OFFICE

Applicant(s):	Jack B. Stubbs, et al.	:	Paper No.:
Serial No.:	09/436,515	:	Group Art Unit: 3764
Filed:	November 9, 1999	:	Examiner: G. E. Richman
For:	Exercise Monitoring System and Methods		

Mail Stop: Amendment
Commissioner for Patents
P.O. Box 1450
Alexandria, VA 22313-1450

RECEIVED
JUL 23 2003
TECHNOLOGY CENTER R3700

Dear Sir:

Transmitted herewith is an Amendment in the above-identified application.

- additional fee is required.
- also attached: *Return Postcard*

The fee has been calculated as shown below:

	NO. OF CLAIMS	HIGHEST PREVIOUS PAID FOR	EXTRA CLAIMS	RATE	FEE
Total Claims		57	0	x \$9 =	\$
Independent Claims		9	0	x \$42 =	\$
If multiple claims newly presented, add \$135.00					-----
Two Month Extension Fee					\$ 205.00
Information Disclosure Statement					\$000.00
TOTAL FEE DUE					\$ 205.00

- A check in the amount of \$ is enclosed.
- Please charge my Deposit Account No. 04-1133 in the amount of \$ 205.00.
- The Commissioner is hereby authorized to charge payment of any additional fees associated with this communication or credit any overpayment, to Deposit Account No. 04-1133, including any filing fees under 37 CFR 1.16 for presentation of extra claims and any patent application processing fees under 37 CFR 1.17.

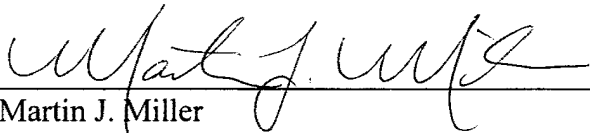

Respectfully submitted,

By: 
Martin J. Miller
Registration No. 35,953

DINSMORE & SHOHL, LLP
1900 Chemed Center
255 East Fifth Street
Cincinnati, Ohio 45202
(513) 977-
Date: July 14, 2003

Docket No: 24278-1

CERTIFICATE OF MAILING

I hereby certify that this paper is being deposited with the United States Postal Service with sufficient postage as first class mail in an envelope addressed to: Commissioner for Patents, P.O. Box 1450, Alexandria, Virginia 22313-14560 on May 13, 2003.

Stephanie Berlepsch
Stephanie Berlepsch



3764
PATENT #16

IN THE UNITED STATES PATENT & TRADEMARK OFFICE

Applicant: Jack B. Stubbs, et al.
Serial No.: 09/436,515 Group Art Unit: 3764
Filed: November 9, 1999 Examiner: G. E. Richman
For: **Exercise Monitoring System and Methods**

SUPPLEMENTAL INFORMATION DISCLOSURE STATEMENT

Commissioner for Patents
P.O. Box 1450
Alexandria, VA 22313-1450

RECEIVED
MAY 23 2003
TECHNOLOGY CENTER

Dear Sir:

In accordance with 37 C.F.R. §§ 1.97 and 1.98 Applicant herewith submits a certain patent reference which the Patent & Trademark Office may wish to consider in examining the above-identified application. The reference is listed on the attached Form PTO-1449.

A copy of the listed reference is also provided. No representation is made or intended that a prior art search has been made or that no better art than that listed is available.

The undersigned hereby states that no item of information in this Supplemental Information Disclosure Statement was cited in a communication from a foreign patent office in a counterpart foreign application, and, to my knowledge after making reasonable inquiry, no item of information contained in this Supplemental Information Disclosure Statement was known to any individual designated in 37 CFR 1.56(c) more than 3 months prior to the filing of this Supplemental Information Disclosure Statement.

Please charge any fees required for this Supplemental Information Disclosure Statement, or credit any overpayment, to Deposit Account No. 04-1133.

Respectfully submitted,

By:

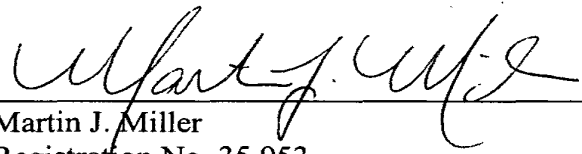

Martin J. Miller
Registration No. 35,953
Attorney for Applicant(s)
DINSMORE & SHOHL, LLP
1900 Chemed Center
255 East Fifth Street
Cincinnati, Ohio 45202
(513) 977-8565



UNITED STATES PATENT AND TRADEMARK OFFICE

UNITED STATES DEPARTMENT OF COMMERCE
United States Patent and Trademark Office
Address: COMMISSIONER OF PATENTS AND TRADEMARKS
Washington, D.C. 20231
www.uspto.gov

APPLICATION NO.	FILING DATE	FIRST NAMED INVENTOR	ATTORNEY DOCKET NO.	CONFIRMATION NO.
09/436,515	11/09/1999	JACK B. STUBBS	24278-1	6756

7590 02/12/2003

DINSMORE AND SHOHL LLP
1900 CHEMED CENTER
255 EAST FIFTH STREET
CINCINNATI, OH 45202

EXAMINER	
RICHMAN, GLENN E	
ART UNIT	PAPER NUMBER
3764	

DATE MAILED: 02/12/2003

Please find below and/or attached an Office communication concerning this application or proceeding.

Office Action Summary

Application No. 09/436,515	Applicant(s) Stubbs et al
Examiner Glenn Richman	Art Unit 3764

-- The MAILING DATE of this communication appears on the cover sheet with the correspondence address --

Period for Reply

A SHORTENED STATUTORY PERIOD FOR REPLY IS SET TO EXPIRE 3 MONTH(S) FROM THE MAILING DATE OF THIS COMMUNICATION.

- Extensions of time may be available under the provisions of 37 CFR 1.136 (a). In no event, however, may a reply be timely filed after SIX (6) MONTHS from the mailing date of this communication.
- If the period for reply specified above is less than thirty (30) days, a reply within the statutory minimum of thirty (30) days will be considered timely.
- If NO period for reply is specified above, the maximum statutory period will apply and will expire SIX (6) MONTHS from the mailing date of this communication.
- Failure to reply within the set or extended period for reply will, by statute, cause the application to become ABANDONED (35 U.S.C. § 133).
- Any reply received by the Office later than three months after the mailing date of this communication, even if timely filed, may reduce any earned patent term adjustment. See 37 CFR 1.704(b).

Status

- 1) Responsive to communication(s) filed on Nov 25, 2002
- 2a) This action is FINAL. 2b) This action is non-final.
- 3) Since this application is in condition for allowance except for formal matters, prosecution as to the merits is closed in accordance with the practice under *Ex parte Quayle*, 1935 C.D. 11; 453 O.G. 213.

Disposition of Claims

- 4) Claim(s) 1-12, 14-18, and 59-76 is/are pending in the application.
- 4a) Of the above, claim(s) _____ is/are withdrawn from consideration.
- 5) Claim(s) _____ is/are allowed.
- 6) Claim(s) 1-12, 14-18, and 59-76 is/are rejected.
- 7) Claim(s) _____ is/are objected to.
- 8) Claims _____ are subject to restriction and/or election requirement.

Application Papers

- 9) The specification is objected to by the Examiner.
- 10) The drawing(s) filed on _____ is/are a) accepted or b) objected to by the Examiner.
Applicant may not request that any objection to the drawing(s) be held in abeyance. See 37 CFR 1.85(a).
- 11) The proposed drawing correction filed on _____ is: a) approved b) disapproved by the Examiner.
If approved, corrected drawings are required in reply to this Office action.
- 12) The oath or declaration is objected to by the Examiner.

Priority under 35 U.S.C. §§ 119 and 120

- 13) Acknowledgement is made of a claim for foreign priority under 35 U.S.C. § 119(a)-(d) or (f).
- a) All b) Some* c) None of:
- Certified copies of the priority documents have been received.
 - Certified copies of the priority documents have been received in Application No. _____
 - Copies of the certified copies of the priority documents have been received in this National Stage application from the International Bureau (PCT Rule 17.2(a)).

*See the attached detailed Office action for a list of the certified copies not received.

- 14) Acknowledgement is made of a claim for domestic priority under 35 U.S.C. § 119(e).
- a) The translation of the foreign language provisional application has been received.
- 15) Acknowledgement is made of a claim for domestic priority under 35 U.S.C. §§ 120 and/or 121.

Attachment(s)

- 1) Notice of References Cited (PTO-892)
- 2) Notice of Draftsperson's Patent Drawing Review (PTO-948)
- 3) Information Disclosure Statement(s) (PTO-1449) Paper No(s). _____
- 4) Interview Summary (PTO-413) Paper No(s). _____
- 5) Notice of Informal Patent Application (PTO-152)
- 6) Other:

Art Unit: 3764

1. The following is a quotation of the appropriate paragraphs of 35 U.S.C. 102 that form the basis for the rejections under this section made in this Office action:

A person shall be entitled to a patent unless -

(e) the invention was described in a patent granted on an application for patent by another filed in the United States before the invention thereof by the applicant for patent, or on an international application by another who has fulfilled the requirements of paragraphs (1), (2), and (4) of section 371© of this title before the invention thereof by the applicant for patent.

The changes made to 35 U.S.C. 102(e) by the American Inventors Protection Act of 1999 (AIPA) do not apply to the examination of this application as the application being examined was not (1) filed on or after November 29, 2000, or (2) voluntarily published under 35 U.S.C. 122(b). Therefore, this application is examined under 35 U.S.C. 102(e) prior to the amendment by the AIPA (pre-AIPA 35 U.S.C. 102(e)).

2. Claims 1, 3-12, 14, 16, 59, 62-70 are rejected under 35 U.S.C. 102(e) as being anticipated by Root et al.

Root et al disclose an electronic positioning device (101), a physiological monitor (col. 4, lines 4-39), a display unit configured ... one of location, altitude, velocity and distance traveled (112).

As for claims 3-12, 14, 16, Root et al further disclose GPS (101), a heart rate monitor (col. 2, lines 17-20), provided as a data acquisition unit separate from the display unit (fig. 7), a support member ... waist (203), a probe (col. 10, lines 25-28).

As for claims 59, 62-70, Roots et al further disclose a display screen (fig. 7), simultaneously displays at least one of a subjects velocity, pace and distance traveled and physiological data (abstract), a memory (608), a processor (602), communication via wired or wireless (fig.1), radio waves (col. 4, lines 4-27), workload (abstract), weight (col 7, lines 1-5)

Art Unit: 3764

3. The following is a quotation of 35 U.S.C. 103(a) which forms the basis for all obviousness rejections set forth in this Office action:

(a) A patent may not be obtained though the invention is not identically disclosed or described as set forth in section 102 of this title, if the differences between the subject matter sought to be patented and the prior art are such that the subject matter as a whole would have been obvious at the time the invention was made to a person having ordinary skill in the art to which said subject matter pertains. Patentability shall not be negated by the manner in which the invention was made.

4. Claims 2, 15, 17, 18, 71 -76 are rejected under 35 U.S.C. 103(a) as being unpatentable over Roots et al.

Roots et al do not specifically disclose an oximeter, however, as Roots et al disclose a complete physical monitor, it would be obvious that an oximeter would be included in such.

Roots et al further disclose the use of preset targets, and notifying the user whether they are reached, it could obviously be done with an alarm, or considered such (abstract).

Roots et al do not specifically disclose the GPS signals are electromagnetic, however, it is well known in the art, the GPS devices use electromagnetic signals, so it would be obvious that Roots et al can use or uses electromagnetic signals.

Roots et al further disclose the use of preset targets, and notifying the user whether they are reached, it could obviously be done with an alarm, or considered such (abstract).

5. Claims 60,61 are rejected under 35 U.S.C. 103(a) as being unpatentable over Roots et al in view of Seiple et al.

Roots et al do not disclose a heads up display.

Art Unit: 3764

Seiple discloses a heads up display used with a GPS system for monitoring (col. 6, lines 24-45).

It would have been obvious to use Seiple's HUD with Roots et al GPS system, as it is well known as taught by Seiple for using a HUD with a GPS system, for displaying to a user the monitored information.

6. Any inquiry concerning this communication or earlier communications from the examiner should be directed to Glenn Richman whose telephone number is (703)308-3170. The examiner can normally be reached Tuesday through Thursday from 7:30 AM to 6:00 PM Eastern time. The facsimile number for Art Unit 3764 is (703)308-0758. The facsimile number for submitting formal papers to Technology Center 3700 is (703)305-3590.

Any inquiry of a general nature or relating to the status of this application or proceeding should be directed to the Group 3700 receptionist whose telephone number is (703)308-0858 or to Customer Service at (703)306-6789.

gr
February 9, 2003

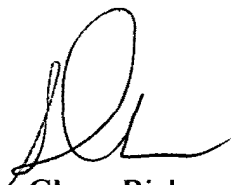

Glenn Richman
Primary Examiner
AU 3764

Notice of References Cited

Application/Control No. 09/436,515		Applicant(s)/Patent Under Reexam Stubbs et al	
Examiner Glenn Richman	Art Unit 3764	Page 1 of 1	

U.S. PATENT DOCUMENTS

	Document Number Country Code-Number-Kind Code	Date MM-YYYY ¹	Name	Classification ²	
A	6,013,007	1/2000	Roots et al	482	8
B	6,032,108	2/2000	Seiple et al	702	97
C					
D					
E					
F					
G					
H					
I					
J					
K					
L					
M					

FOREIGN PATENT DOCUMENTS

	Document Number Country Code-Number-Kind Code	Date MM-YYYY ¹	Country	Name	Classification ²	
N						
O						
P						
Q						
R						
S						
T						

NON-PATENT DOCUMENTS

Include, as applicable: Author, Title, Date, Publisher, Edition or Volume, Pertinent Pages	
U	
V	
W	
X	

* A copy of this reference is not being furnished with this Office action. See MPEP § 707.05(a). ¹ Dates in MM-YYYY format are publication dates. ² Classifications may be U.S. or foreign.

T.H.
12-3-02
PATENT
14/B
[Signature]

IP
25 2002

CERTIFICATE OF MAILING

I hereby certify that this paper is being deposited with the United States Postal Service with sufficient postage as first class mail in an envelope addressed to: Box-Fee Amendment; Commissioner for Patents, Washington, DC 20231 on November 18, 2002.

Stephanie Berlepsch
Stephanie Berlepsch

IN THE UNITED STATES PATENT & TRADEMARK OFFICE

Applicant(s): Jack B. Stubbs, et al. : Paper No.:
Serial No.: 09/436,515 : Group Art Unit: 3764
Filed: November 9, 1999 : Examiner: G. E. Richman
For: **Exercise Monitoring System and Methods**

AMENDMENT

RECEIVED
DEC - 2 2002
TECHNOLOGY CENTER R3700

Box Fee Amendment
Commissioner for Patents
Washington, D.C. 20231

Dear Sir:

In response to the Office Action dated June 18, 2002, please amend the present application as follows:

In the Specification:

Please replace the text of the Abstract of the Disclosure beginning on page 59, line 2, with the following:

B --An exercise monitoring system which includes an electronic positioning device; a physiological monitor; and a display unit configured for displaying data provided by the electronic positioning device and the physiological monitor.--

In the claims:

Please amend claim 1 as follows:

B

- C
B2
1. (amended) An exercise monitoring system, comprising:
 - (a) an electronic positioning device;
 - (b) a physiological monitor; and
 - (c) a display unit configured for displaying data provided by said electronic positioning device and said physiological monitor;wherein said system is configured such that said display unit displays at least one of a subject's location, altitude, velocity, pace, and distance traveled.

Remarks

In the Office Action dated June 18, 2002, the Examiner rejected all of the pending claims (1-12, 14-18 and 59-76) under 35 U.S.C. § 102(e) as being anticipated by Kramer (U.S. Patent No. 6,148,280). However, Kramer is directed to the collection of "motion data" rather than the monitoring and display of exercise performance data (such as a subject's velocity, pace or distance traveled). In other words, the system taught by Kramer collects data on the movement of a body part, whereas the present invention displays data on the movement of the subject as a whole (such as a person running). In light of this fundamental difference between Kramer and the present invention, it is not surprising that Kramer fails to teach or suggest many of the limitations found in the pending claims.

In particular, claim 1, as amended herein, is directed to an exercise monitoring system comprising an electronic positioning device, a physiological monitor, and a display unit which displays data provided by the electronic positioning device and the physiological monitor. The displayed data includes a subject's location, altitude, velocity, pace, and/or distance traveled. As the Examiner is aware, in order to find anticipation, each and every limitation of the claim must be disclosed in a single prior art reference. *Atlas Powder Co. v. IRECO Inc.*, 51 USPQ2d 1943, 1945-46 (Fed. Cir. 1999). Kramer, however, does not disclose or suggest any display device, let alone a display device which displays the type of data required by

claim 1.¹ In addition, the device taught by Kramer is not even capable of determining a subject's location, altitude, velocity, pace, or distance traveled, as it only provides data regarding the movement of "body parts." Thus, Kramer cannot anticipate claim 1.²

Although the claims depending from claim 1 are allowable given that claim 1 is believed to be allowable, numerous limitations contained within these dependent claims are not taught or suggested by Kramer. For example, several of the dependent claims concern structural aspects of the exercise monitoring system which are not even remotely suggested by Kramer (e.g., claims 8, 11, 12, and 60). Similarly, several claims depending from claim 1 include limitations with respect to the processing of acquired data. Once again these claims include limitations which are not disclosed or suggested by Kramer (e.g., claims 15, 17, 62, 68, 69, 71, 72 and 73). By way of example, dependent claim 73 requires that the system compute and display the "time variability of a subject's blood oxygen level." Kramer does not suggest the use of a blood oxygen sensor, let alone the computation and display of the time variability of a subject's blood oxygen level. For these reasons, the claims depending from claim 1 clearly are neither anticipated nor rendered obvious by Kramer (either alone or in combination with any other cited reference).

With respect to independent claim 18, this claim is directed to an exercise monitoring system comprising an electronic positioning device, a display unit configured for displaying data provided by the electronic positioning device, and an alarm which is activated when the subject's velocity or pace does not meet a predetermined target. Not only does Kramer fail to disclose or suggest a device which determines a subject's velocity or pace, nowhere does Kramer teach or suggest the inclusion of an alarm which is activated on the basis of the subject's velocity or pace. In fact, Kramer provides only generic statements with respect to the ultimate use of the collected data. Here, Kramer does not even remotely suggest the inclusion of an alarm, let alone one which is activated on the basis of the

¹ It should be noted that reference numeral 274 in FIG. 2 of Kramer identifies an "eyegaze sensor", not a display device (see col. 15, lines 36-40).

² For the same reasons, Kramer, alone or in combination with any other cited reference, cannot render claim 1 obvious, since any display device used in conjunction with the apparatus taught by Kramer would not display the type of data specified in claim 1.

subject's velocity or pace. Therefore, claim 18, as well as those claims depending therefrom, cannot be anticipated by Kramer.

For the reasons stated above, Applicants respectfully request that the Examiner allow all of the pending claims for this application.

Respectfully submitted,

By

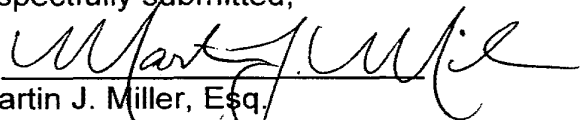

Martin J. Miller, Esq.

Registration No. 35,953

Attorney for Applicant(s)

DINSMORE & SHOHL LLP

1900 Chemed Center

255 East Fifth Street

Cincinnati, Ohio 45202

(513) 977-8565

846313.01

VERSION WITH MARKINGS TO SHOW CHANGES MADE

In the Specification:

The text of the Abstract of the Disclosure beginning on page 59, line 2, has been amended as follows:

An exercise monitoring system which includes an electronic positioning device; a physiological monitor; and a display unit configured for displaying data provided by [said] the electronic positioning device and [said] the physiological monitor.

In the Claims:

Claim 1 has been amended as follows:

1. (amended) An exercise monitoring system, comprising:
 - (a) an electronic positioning device;
 - (b) a physiological monitor; and
 - (c) a display unit configured for displaying data provided by said electronic positioning device and said physiological monitor;

wherein said system is configured such that said display unit displays at least one of a subject's location, altitude, velocity, pace, and distance traveled.



3764
#

Packet No: 24278-1
CERTIFICATE OF MAILING

PATENT

I hereby certify that this paper is being deposited with the United States Postal Service with sufficient postage as first class mail in an envelope addressed to: Box-Fee Amendment; Commissioner for Patents, Washington, DC 20231 on November 18, 2002.

Stephanie Berlepsch
Stephanie Berlepsch

IN THE UNITED STATES PATENT & TRADEMARK OFFICE

Applicant: Jack B. Stubbs, et al. Paper No.:
Serial No.: 09/436,515 Group Art Unit: 3764
Filed: November 9, 1999 Examiner: G. E. Richman
For: Exercise Monitoring System and Methods

RECEIVED
DEC - 2 2002

Box-Fee Amendment
Commissioner for Patents
Washington, DC 20231

TECHNOLOGY CENTER R3700

Dear Sir:

Transmitted herewith is a Response to the Office Action mailed on June 18, 2002 in the above-identified application.

- [x] additional fee is required.
- [x] also attached: Two Month Extension of Time, Return Receipt Postcard

The fee has been calculated as shown below:

	NO. OF CLAIMS	HIGHEST PREVIOUS PAID FOR	EXTRA CLAIMS	RATE	FEE
Total Claims		57	0	x \$18 =	\$
Independent Claims		9	0	x \$84 =	\$
If multiple claims newly presented, add \$135.00					-----
Extension Fee					\$400.00
Information Disclosure Statement					\$0.00
TOTAL FEE DUE					\$0.00

- [] A check in the amount of \$___ is enclosed.
- [x] Please charge my Deposit Account No. 04-1133 in the amount of \$400.00
- [x] The Commissioner is hereby authorized to charge payment of any additional fees associated with this communication or credit any overpayment, to Deposit Account No. 04-1133, including any filing fees under 37 CFR 1.16 for presentation of extra claims and any patent application processing fees under 37 CFR 1.17.

B



Respectfully submitted,

By: *Martin J. Miller*

Martin J. Miller
Registration No. 35,953
DINSMORE & SHOHL, LLP
1900 Chemed Center
255 East Fifth Street
Cincinnati, Ohio 45202
(513) 977-8565

Dated: November 18, 2002

847104_1

RECEIVED
DEC - 2 2002
TECHNOLOGY CENTER R3700



Docket No: 24278-1

CERTIFICATE OF MAILING

I hereby certify that this paper is being deposited with the United States Postal Service with sufficient postage as first class mail in an envelope addressed to: Box-Fee Amendment; Commissioner for Patents, Washington, DC 20231 on November 18, 2002.

Stephan Berlepsch
Stephan Berlepsch

RECEIVED

DEC - 2 2002

TECHNOLOGY CENTER R3700

PATENT

T.H.
12-3-02
#13/Ext
of
time
(JHO)

IN THE UNITED STATES PATENT & TRADEMARK OFFICE

Applicant:	Jack B. Stubbs, et al.	Paper No.:	
Serial No.:	09/436,515	Group Art Unit:	3764
Filed:	November 9, 1999	Examiner:	G. E. Richman
For:	Exercise Monitoring System and Methods		

REQUEST FOR EXTENSION OF TIME

Box-Fee Amendment
Commissioner for Patents
Washington, DC 20231

Dear Sir:

Submitted herewith is an Amendment in response to the Office Action mailed June 18, 2002.

Applicant petitions the Commissioner of Patents & Trademarks to extend the time for response to the Office Action dated June 18, 2002 for 2 month(s) from September 18, 2002 to November 18, 2002.

Please charge the fee for this extension, as well as any other deficiency with respect to this Amendment, to Deposit Account No. 04-1133.

Respectfully submitted,

By: Martin J. Miller

Martin J. Miller
Registration No. 35,953
Attorney for Applicant(s)
DINSMORE & SHOHL, LLP
1900 Chemed Center
255 East Fifth Street
Cincinnati, Ohio 45202
(513) 977-8565

11/27/2002 09436515 0000064 041133 400.00 CH

(245)
JHO
2018-00294



UNITED STATES PATENT AND TRADEMARK OFFICE

UNITED STATES DEPARTMENT OF COMMERCE
United States Patent and Trademark Office
Address: COMMISSIONER OF PATENTS AND TRADEMARKS
Washington, D.C. 20231
www.uspto.gov

APPLICATION NO.	FILING DATE	FIRST NAMED INVENTOR	ATTORNEY DOCKET NO.	CONFIRMATION NO.
09/436,515	11/09/1999	JACK B. STUBBS	24278-1	6756

7590 06/18/2002

DINSMORE AND SHOHL LLP
1900 CHEMED CENTER
255 EAST FIFTH STREET
CINCINNATI, OH 45202

EXAMINER

RICHMAN, GLENN E

ART UNIT PAPER NUMBER

3764

DATE MAILED: 06/18/2002

#12

Please find below and/or attached an Office communication concerning this application or proceeding.

Office Action Summary

Application No. 09/436,515	Applicant(s) Stubbs et al
Examiner Glenn Richman	Art Unit 3764

-- The MAILING DATE of this communication appears on the cover sheet with the correspondence address --

Period for Reply

A SHORTENED STATUTORY PERIOD FOR REPLY IS SET TO EXPIRE 3 MONTH(S) FROM THE MAILING DATE OF THIS COMMUNICATION.

- Extensions of time may be available under the provisions of 37 CFR 1.136 (a). In no event, however, may a reply be timely filed after SIX (6) MONTHS from the mailing date of this communication.
- If the period for reply specified above is less than thirty (30) days, a reply within the statutory minimum of thirty (30) days will be considered timely.
- If NO period for reply is specified above, the maximum statutory period will apply and will expire SIX (6) MONTHS from the mailing date of this communication.
- Failure to reply within the set or extended period for reply will, by statute, cause the application to become ABANDONED (35 U.S.C. § 133).
- Any reply received by the Office later than three months after the mailing date of this communication, even if timely filed, may reduce any earned patent term adjustment. See 37 CFR 1.704(b).

Status

- 1) Responsive to communication(s) filed on Mar 28, 2002
- 2a) This action is FINAL. 2b) This action is non-final.
- 3) Since this application is in condition for allowance except for formal matters, prosecution as to the merits is closed in accordance with the practice under *Ex parte Quayle*, 1035 C.D. 11; 453 O.G. 213.

Disposition of Claims

- 4) Claim(s) 1-12, 14-18, and 59-76 is/are pending in the application.
- 4a) Of the above, claim(s) _____ is/are withdrawn from consideration.
- 5) Claim(s) _____ is/are allowed.
- 6) Claim(s) 1-12, 14-18, and 59-76 is/are rejected.
- 7) Claim(s) _____ is/are objected to.
- 8) Claims _____ are subject to restriction and/or election requirements.

Application Papers

- 9) The specification is objected to by the Examiner.
- 10) The drawing(s) filed on _____ is/are a) accepted or b) objected to by the Examiner.
Applicant may not request that any objection to the drawing(s) be held in abeyance. See 37 CFR 1.85(a).
- 11) The proposed drawing correction filed on _____ is: a) approved b) disapproved by the Examiner.
If approved, corrected drawings are required in reply to this Office action.
- 12) The oath or declaration is objected to by the Examiner.

Priority under 35 U.S.C. §§ 119 and 120

- 13) Acknowledgement is made of a claim for foreign priority under 35 U.S.C. § 119(a)-(d) or (f).
a) All b) Some* c) None of:
- Certified copies of the priority documents have been received.
 - Certified copies of the priority documents have been received in Application No. _____.
 - Copies of the certified copies of the priority documents have been received in this National Stage application from the International Bureau (PCT Rule 17.2(a)).
- *See the attached detailed Office action for a list of the certified copies not received.
- 14) Acknowledgement is made of a claim for domestic priority under 35 U.S.C. § 119(e).
a) The translation of the foreign language provisional application has been received.
- 15) Acknowledgement is made of a claim for domestic priority under 35 U.S.C. §§ 120 and/or 121.

Attachment(s)

- 1) Notice of References Cited (PTO-892) 4) Interview Summary (PTO-413) Paper No(s). _____
- 2) Notice of Draftsperson's Patent Drawing Review (PTO-948) 5) Notice of Informal Patent Application (PTO-152)
- 3) Information Disclosure Statement(s) (PTO-1449) Paper No(s). 4, 5, 10 6) Other:

Art Unit: 3764

1. The abstract of the disclosure is objected to because of use of legal phraseology, i.e., "said". Correction is required. See MPEP § 608.01(b).
2. Applicant is reminded of the proper language and format for an abstract of the disclosure.

The abstract should be in narrative form and generally limited to a single paragraph on a separate sheet within the range of 50 to 150 words. It is important that the abstract not exceed 150 words in length since the space provided for the abstract on the computer tape used by the printer is limited. The form and legal phraseology often used in patent claims, such as "means" and "said," should be avoided. The abstract should describe the disclosure sufficiently to assist readers in deciding whether there is a need for consulting the full patent text for details.

The language should be clear and concise and should not repeat information given in the title. It should avoid using phrases which can be implied, such as, "The disclosure concerns," "The disclosure defined by this invention," "The disclosure describes," etc.

3. The following is a quotation of the appropriate paragraphs of 35 U.S.C. 102 that form the basis for the rejections under this section made in this Office action:

A person shall be entitled to a patent unless -

(e) the invention was described in a patent granted on an application for patent by another filed in the United States before the invention thereof by the applicant for patent, or on an international application by another who has fulfilled the requirements of paragraphs (1), (2), and (4) of section 371© of this title before the invention thereof by the applicant for patent.

Art Unit: 3764

The changes made to 35 U.S.C. 102(e) by the American Inventors Protection Act of 1999 (AIPA) do not apply to the examination of this application as the application being examined was not (1) filed on or after November 29, 2000, or (2) voluntarily published under 35 U.S.C. 122(b). Therefore, this application is examined under 35 U.S.C. 102(e) prior to the amendment by the AIPA (pre-AIPA 35 U.S.C. 102(e)).

4. Claims 1-12, 14-18, 59-76 are rejected under 35 U.S.C. 102(e) as being clearly anticipated by Kramer.

The prior art made of record and not relied upon is considered pertinent to applicant's disclosure.

Nagatsuma et al disclose a portable GPS type for distance and speed.

5. Any inquiry concerning this communication or earlier communications from the examiner should be directed to Glenn Richman whose telephone number is (703)308-3170. The examiner can normally be reached Tuesday through Thursday from 7:30 AM to 6:00 PM Eastern time. The facsimile number for Art Unit 3764 is (703)308-0758. The facsimile number for submitting formal papers to Technology Center 3700 is (703)305-3590.

Any inquiry of a general nature or relating to the status of this application or proceeding should be directed to the Group 3700 receptionist whose telephone number is (703)308-0858 or to Customer Service at (703)306-6789.

gr
June 13, 2002

Glenn Richman
Primary Examiner
AU 3764

Notice of References Cited

Application/Control No. 09/436,515		Applicant(s)/Patent Under Reexam Stubbs et al	
Examiner Glenn Richman		Art Unit 3764	Page 1 of 1

U.S. PATENT DOCUMENTS

	Document Number Country Code-Number-Kind Code	Date MM-YYYY ¹	Name	Classification ²	
A	6,148,280	11/2000	Kramer	703	153
B	6,285,314	9/2001	Nagatsuma et al	482	8
C					
D					
E					
F					
G					
H					
I					
J					
K					
L					
M					

FOREIGN PATENT DOCUMENTS

	Document Number Country Code-Number-Kind Code	Date MM-YYYY ¹	Country	Name	Classification ²
N					
O					
P					
Q					
R					
S					
T					

NON-PATENT DOCUMENTS

	Include, as applicable: Author, Title, Date, Publisher, Edition or Volume, Pertinent Pages
U	
V	
W	
X	

* A copy of this reference is not being furnished with this Office action. See MPEP § 707.05(a). ¹ Dates in MM-YYYY format are publication dates. ² Classifications may be U.S. or foreign.



PTO FORM 4/92 FORM PTO - 1449 LIST OF PATENTS AND PUBLICATIONS FOR APPLICANT'S INFORMATION DISCLOSURE STATEMENT (Supplemental)	ATTY DOCKET.: 24278 APPLICANT: Jack B. Stubbs, et al. FILING DATE: November 9, 1999 FOR: Exercise Monitoring System and Methods	SERIAL NO.: 09/436,515 GROUP: 3764
----------------------------------------------------------------------------------------------------------------------------------------------------------------------------------	----------------------------------------------------------------------------------------------------------------------------------------------------------------------	---------------------------------------------------------

UNITED STATES LETTERS PATENT

Exr. Inif.	DOCUMENT NUMBER							DATE	NAME	CLASS	SUB CLASS
M	6	0	0	2	9	8	2	Dec. 14, 1999	Fry	—	—
M	6	0	3	2	1	0	8	Feb. 29, 2000	Seiple et al.	—	—
M	6	1	4	8	2	6	2	Nov. 14, 2000	Fry	—	—

RECEIVED
APR - 1 2002
TECHNOLOGY CENTER R3700

FOREIGN PATENT DOCUMENTS

Exr. Inif.	DOCUMENT NUMBER							DATE	COUNTRY	CLASS	SUB CLASS
M	WO	01	4	1	8	7	9	14 June 2001	PCT	—	—

OTHER ART (INCLUDING AUTHOR, TITLE DATE, PERTINENT PAGES, ETC.)

EXAMINER: *Rechner* DATE CONSIDERED *6/13/02*
 EXAMINER: Initial if reference considered, whether or not citation is in conformance with MPEP 609; Draw line through citation if not in conformance and no considered. Include copy of this form with next communication to applicant.

PTO FORM 4/92 Page 1 of 1

FORM PTO - 1449 LIST OF PATENTS AND PUBLICATIONS FOR APPLICANT'S INFORMATION DISCLOSURE STATEMENT (Supplemental)	ATTY DOCKET.: 24278 APPLICANT: Jack B. Stubbs, et al. FILING DATE: November 9, 1999 FOR: Exercise Monitoring System and Methods	SERIAL NO.: 09/436,515 GROUP: 3764
----------------------------------------------------------------------------------------------------------------------------------------------------------	----------------------------------------------------------------------------------------------------------------------------------------------------------------------	---------------------------------------------------------

UNITED STATES LETTERS PATENT

Exr. Init.	DOCUMENT NUMBER							DATE	NAME	CLASS	SUB CLASS
/	6	0	0	2	9	8	2	Dec. 14, 1999	Fry	—	—
/	6	0	3	2	1	0	8	Feb. 29, 2000	Seiple et al.	—	—
/	6	1	4	8	2	6	2	Nov. 14, 2000	Fry	—	—

FOREIGN PATENT DOCUMENTS

Exr. Init.	DOCUMENT NUMBER							DATE	COUNTRY	CLASS	SUB CLASS
/	WO	01	4	1	8	7	9	14 June 2001	PCT	—	—

OTHER ART (INCLUDING AUTHOR, TITLE DATE, PERTINENT PAGES, ETC.)

EXAMINER *R. d. m. v.* DATE CONSIDERED *6/13/02*
 EXAMINER: Initial if reference considered, whether or not citation is in conformance with MPEP 609; Draw line through citation if not in conformance and no considered. Include copy of this form with next communication to applicant.

PTO FORM 4/92

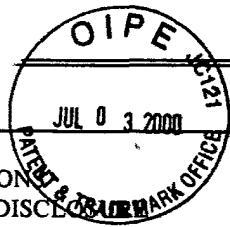

4

FORM PTO-1449
LIST OF PATENTS AND PUBLICATIONS
FOR APPLICANT'S INFORMATION DISCLOSURE
STATEMENT

ATTY DOCKET: 24278-1
SERIAL NO.: 09/436,515
APPLICANT(S): Stubbs, et al.
FILING DATE: November 9, 1999
GROUP: 3661

FOR: EXERCISE MONITORING SYSTEM AND METHODS

PAGE 1 OF PAGE 2

Exam Init	DOCUMENT NUMBER							DATE	NAME	CLASS	SUB CLASS
	4	5	6	6	4	6	1				
	4	5	6	6	4	6	1	01/28/86	Lubell, et al.		
	5	0	8	1	9	9	1	01/21/92	Chance		
	5	1	6	7	2	3	0	12/01/92	Chance		
	5	3	1	8	4	8	7	06/07/94	Golen, et al.		
	5	3	4	5	2	4	4	09/06/94	Gildea et al.		
	5	4	0	8	4	4	4	04/18/95	Kita et al.		
	5	4	5	6	2	6	2	10/10/95	Birnbaum		
	5	4	5	8	5	4	8	10/17/95	Crossing, et al.		
	5	4	6	4	0	2	1	11/07/95	Birnbaum		
	5	4	8	6	8	1	8	01/23/96	Loponen		
	5	4	9	1	4	7	4	02/13/96	Suni et al.		
	5	5	6	4	4	1	7	10/15/96	Chance		
	5	5	7	5	2	8	4	11/19/96	Athan et al.		
	5	5	8	9	8	3	5	12/31/96	Gildea et al.		
	5	6	1	1	3	4	6	03/18/97	Heikkilä et al.		
	5	6	2	2	1	8	0	04/22/97	Tammi et al.		
	5	6	2	7	5	4	8	05/06/97	Woo et al.		
	5	6	3	2	2	7	9	05/27/97	Heikkilä		

RECEIVED
 JUL - 5 2001
 TC 3500 MAIL ROOM

FOREIGN PATENT DOCUMENTS

Exam Init	DOCUMENT NUMBER							DATE	COUNTRY	CLASS	SUB CLASS
	WO	98	1	2	5	9	9				
	WO	98	1	2	5	9	9	26 March 1998	PCT		
	WO	99	2	3	5	2	4	14 May 1999	PCT		
	WO	99	2	3	5	2	5	14 May 1999	PCT		

OTHER ART (INCLUDING AUTHOR, TITLE, DATE, PERTINENT PAGES, ETC.)

EXAMINER: *R. Chinn* DATE CONSIDERED: *6/13/00*
 EXAMINER: Initial if reference considered, whether or not citation is in conformance with MPEP 609; Draw line through citation if not in conformance and not considered. Include copy of this form with next communication to applicant.

576766

PTO FORM 4/92

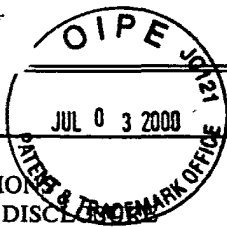

FORM PTO-1449
LIST OF PATENTS AND PUBLICATIONS
FOR APPLICANT'S INFORMATION DISCLOSURE
STATEMENT

ATTY DOCKET: 24278-1
SERIAL NO.: 09/436,515
APPLICANT(S): Stubbs, et al.
FILING DATE: November 9, 1999
GROUP: 3661

FOR: EXERCISE MONITORING SYSTEM AND METHODS

PAGE 2 OF PAGE 2

Exam Incl	DOCUMENT NUMBER								DATE	NAME	CLASS	SUB CLASS
91	5	6	9	0	1	1	9	11/25/97	Rytky et al.			
	5	7	3	1	7	5	7	03/24/98	Layson, Jr.			
	5	7	7	9	6	3	1	07/14/98	Chance			
	5	7	8	1	1	5	5	07/14/98	Woo et al.			
	5	8	1	0	7	2	2	09/22/98	Heikkilä	TC 3600 MAIL ROOM		
	5	8	4	0	0	3	9	11/24/98	Heikkilä	JUL 13 2002	RECEIVED	
	5	8	5	2	4	0	1	12/22/98	Kita	JUL 13 2002	RECEIVED	
	5	8	8	4	1	9	8	03/16/99	Kese et al.	JUL 13 2002	RECEIVED	
	5	8	8	9	4	9	3	03/30/99	Endo	JUL 13 2002	RECEIVED	
	5	8	9	1	0	4	2	04/06/99	Sham et al.	JUL 13 2002	RECEIVED	
	5	9	0	5	4	6	0	05/18/99	Odagiri et al.	JUL 13 2002	RECEIVED	
	5	9	1	9	1	3	3	07/06/99	Taylor et al.	JUL 13 2002	RECEIVED	

FOREIGN PATENT DOCUMENTS

DOCUMENT NUMBER	DATE	COUNTRY	CLASS	SUB CLASS

OTHER ART (INCLUDING AUTHOR, TITLE, DATE, PERTINENT PAGES, ETC.)

EXAMINER *Rechner* DATE CONSIDERED *6/13/02*
EXAMINER: Initial if reference considered, whether or not citation is in conformance with MPEP 609; Draw line through citation if not in conformance and not considered. Include copy of this form with next communication to applicant.

576766

3764



Docket No: 24278-1

PATENT

CERTIFICATE OF MAILING

I hereby certify that this paper is being deposited with the United States Postal Service with sufficient postage as first class mail in an envelope addressed to: Commissioner for Patents, Washington, DC 20231 on March 19, 2002.

Stephanie Berlepsch
Stephanie Berlepsch

RECEIVED
APR - 1 2002
TECHNOLOGY CENTER R3700
4/5
D3
11

IN THE UNITED STATES PATENT & TRADEMARK OFFICE

Applicant: Jack B. Stubbs, et al.
Serial No.: 09/436,515 **Group Art Unit:** 3764
Filed: November 9, 1999 **Examiner:** G. E. Richman
For: **Exercise Monitoring System and Methods**

SUPPLEMENTAL INFORMATION DISCLOSURE STATEMENT

Commissioner for Patents
Washington, DC 20231

Dear Sir:

In accordance with 37 C.F.R. §§ 1.97 and 1.98 Applicant herewith submits certain patent references which the Patent & Trademark Office may wish to consider in examining the above-identified application. The references are listed on the attached Form PTO-1449.

Copies of the listed references are also provided. No representation is made or intended that a prior art search has been made or that no better art than that listed is available.

Please charge any fees required, or credit any overpayment, to Deposit Account No. 04-1133.

Respectfully submitted,

By: *Martin J. Miller*
Martin J. Miller
Registration No. 35,953
Attorney for Applicant(s)
DINSMORE & SHOHL, LLP
1900 Chemed Center
255 East Fifth Street
Cincinnati, Ohio 45202
(513) 977-8565

CERTIFICATE OF FACSIMILE

PATENT

I hereby certify that this correspondence is being transmitted to the Technology Center 3700/United States Patent and Trademark Office at fax number (703) 308-0768 on March 19, 2002. 703 - 305-3590 MEM

Martin J. Miller
Martin J. Miller

#9A
ARIVERS
4/3/02

IN THE UNITED STATES PATENT & TRADEMARK OFFICE

Applicant(s): Jack B. Stubbs, et al. : Paper No.:
Serial No.: 09/436,515 : Group Art Unit: 3764
Filed: November 9, 1999 : Examiner: G. E. Richman
For: **Exercise Monitoring System and Methods**

PRELIMINARY AMENDMENT

Box Non-Fee Amendment
Commissioner for Patents
Washington, D.C. 20231

Dear Sir:

Prior to examination on the merits, please amend the present application as follows:

In the claims:

Please amend claim 6 as follows:

a1

6. (amended) The system of claim 3, wherein said GPS device and said physiological monitor are provided as part of a data acquisition unit which is separate from said display unit.

Please cancel claim 13.

Please amend claim 18 as follows:

18. (amended) An exercise monitoring system, comprising:
(a) an electronic positioning device configured to receive electromagnetic signals from three or more sources so that said monitoring system can determine at least one of a subject's velocity or pace;

a2
GPS

A

CB a2

- (b) a display unit configured for displaying data provided by said electronic positioning device; and
- (c) an alarm, wherein said alarm is activated when a subject's velocity or pace does not meet a predetermined target.

Please cancel claims 19-58.

Please add the following new claims:

59. The exercise monitoring system of claim 1, wherein said display unit is chosen from the group consisting of: a personal computer, a treadmill display screen, and a heads-up type display unit.

3

60. The exercise monitoring system of claim 59, wherein said display unit comprises a heads-up type display unit configured to display said data by projecting the data onto glasses, goggles or a visor, or by projecting the data onto a display screen positioned such that the data will be visible to a user.

61. The exercise monitoring system of claim 6, wherein:

- said data acquisition unit is configured to be worn by a subject performing a physical activity; and
- said display unit is configured to be worn by the subject, worn by someone other than the subject, or attached to an apparatus associated with the physical activity being performed by the subject.

62. The exercise monitoring system of claim 2, wherein said system is configured such that the display unit simultaneously displays: at least one of a subject's velocity, pace and distance traveled; and physiological data provided by said physiological monitor.

63. The exercise monitoring system of claim 6, wherein said system further comprises at least one memory, and at least one processor for processing acquired data in accordance with instructions stored in said at least one memory.

A

¹⁹
 20 64. The exercise monitoring system of claim 63, wherein said data acquisition unit includes memory, and at least one processor for processing acquired data in accordance with instructions stored in said memory of the data acquisition unit, and further wherein said display unit includes memory, and at least one processor for processing acquired data in accordance with instructions stored in said memory of the display unit.

¹⁹
 21/ 65. The exercise monitoring system of claim 63, wherein said at least one memory is configured for storing acquired data for later retrieval.

bls
 66. The exercise monitoring system of claim 6, wherein said display unit is configured for communication with said data acquisition unit via a wired or wireless link, such that data indicative of at least one of a subject's velocity or pace can be transmitted to said display unit.

²²
 23 67. The exercise monitoring system of claim 66, wherein said display unit is configured for communication with said data acquisition unit via radio waves.

²⁴
 24 68. The exercise monitoring system of claim 1, wherein said system is configured for computing a subject's workload based on the subject's velocity and altitude changes, and displaying the computed workload.

²⁴
 25 69. The exercise monitoring system of claim 68, wherein said system is configured for the input of a subject's weight, and said system is configured for computing a subject's workload based on the subject's velocity, altitude changes and inputted weight.

²⁶
 26 70. The exercise monitoring system of claim 1, wherein said system is configured for electrical communication with an external computer such that acquired data may be stored in the computer.

¹⁵
 27 71. The exercise monitoring system of claim 17, wherein said physiological monitor comprises an oximeter, and wherein said system is configured such that

said alarm is activated when a subject's blood oxygen level does not meet a predetermined target.

28 ~~72~~ The exercise monitoring system of claim ²⁷~~11~~, wherein said system is configured such that a plurality of predetermined targets for blood oxygen level may be input into said system.

¹⁶~~73~~ The exercise monitoring system of claim 1, wherein said physiological monitor comprises an oximeter, and wherein said system is configured for computing and displaying the time variability of a subject's blood oxygen level.

30 ~~74~~ The exercise monitoring system of claim ²⁹~~18~~, wherein said electronic positioning device comprises a GPS device.

75. The exercise monitoring system of claim 74, wherein said GPS device is provided as part of a data acquisition unit which is separate from said display unit.

76. The exercise monitoring system of claim 75, wherein said data acquisition unit further comprises a support member, and said GPS device is removably secured to said support member.

Remarks

In light of the previous election of claims 1-18, pending claims 19-58 have been cancelled. Applicants reserve the right to pursue these claims by way of one or more divisional applications.

Claim 13 has been cancelled since it is duplicative of claim 11.

The amendments to claims 6 and 18 herein are fully supported by the application as originally filed, and therefore do not involve new matter.

Claims 59-76 have been added herein, and are also fully supported by the application as originally filed and therefore do not involve new matter.

56

A

In light of the cancellation of claims 19-58, no additional fees are believed due for the above amendment, however the Commissioner of Patents and Trademarks is hereby authorized to charge any fees deemed necessary for entry and filing of this Amendment to Dinsmore & Shohl, Account No. 04-1133.

Respectfully submitted,

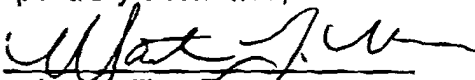
By 

Martin J. Miller, Esq.
Registration No. 35,953
Attorney for Applicant(s)
DINSMORE & SHOHL LLP
1900 Chemed Center
255 East Fifth Street
Cincinnati, Ohio 45202
(513) 977-8565

764134_1

A

VERSION WITH MARKINGS TO SHOW CHANGES MADE

Claim 6 has been amended as follows:

6. (amended) The system of claim 3, wherein said GPS device and said physiological monitor are provided as part of a [user-wearable] data acquisition unit which is separate from said display unit.

Claim 13 has been cancelled.

Claim 18 has been amended as follows:

18. (amended) An exercise monitoring system, comprising:
- (a) an electronic positioning device configured to receive electromagnetic signals from three or more sources so that said monitoring system can determine at least one of a subject's velocity or pace;
 - (b) a display unit configured for displaying data provided by said electronic positioning device; and
 - (c) an alarm, wherein said alarm is activated when a subject's velocity or pace does not meet a predetermined target.

Claims 19-58 have been cancelled.

Claims 59-76 have been added.

Docket No: 24278-1

PATENT

CERTIFICATE OF MAILING

I hereby certify that this paper is being deposited with the United States Postal Service with sufficient postage as first class mail in an envelope addressed to: Commissioner for Patents, Washington, DC 20231 on March 19, 2002.

Stephanie Berlepsch
Stephanie Berlepsch

#10
ALWAYS
4/3/02

IN THE UNITED STATES PATENT & TRADEMARK OFFICE

Applicant: Jack B. Stubbs, et al.
Serial No.: 09/436,515 Group Art Unit: 3764
Filed: November 9, 1999 Examiner: G. E. Richman
For: **Exercise Monitoring System and Methods**

SUPPLEMENTAL INFORMATION DISCLOSURE STATEMENT

Commissioner for Patents
Washington, DC 20231

Dear Sir:

In accordance with 37 C.F.R. §§ 1.97 and 1.98 Applicant herewith submits certain patent references which the Patent & Trademark Office may wish to consider in examining the above-identified application. The references are listed on the attached Form PTO-1449.

Copies of the listed references are also provided. No representation is made or intended that a prior art search has been made or that no better art than that listed is available.

Please charge any fees required, or credit any overpayment, to Deposit Account No. 04-1133.

Respectfully submitted,

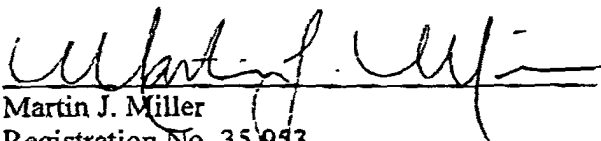
By: 
Martin J. Miller
Registration No. 35,953
Attorney for Applicant(s)
DINSMORE & SHOHL, LLP
1900 Chemed Center
255 East Fifth Street
Cincinnati, Ohio 45202
(513) 977-8565

DINSMORE & SHOHL P.L.L.
FACSIMILE TRANSMITTAL from **MARTIN J. MILLER, ESQ.**

MARCH 19, 2002

To: Examiner Glenn Richman/Technology Center 2700
Fax #: (703) ~~308-0750~~ 305-3590 *MM*
Firm: United States Patent & Trademark Office
Client #: 24278-1
Pages: 9
(including cover)

FAX RECEIVED

MAR 19 2002

GROUP 3700

Comments: 09/436,515
Applicant(s): Jack B. Stubbs, et al.
Title: Exercise Monitoring System and Methods
Filed: November 9, 1999
Attachments: Preliminary Amendment
Courtesy Copy of Supplemental IDS

CERTIFICATE OF FACSIMILE

I hereby certify that this correspondence is being facsimile transmitted to the Technology Center 3700/United States Patent and Trademark Office at fax number ~~703-308-0750~~ 305-3590 *MM*

MARTIN J. MILLER
Typed Name of Person Signing

Martin J. Miller
Signature

March 19, 2002
Date

O I P E
FEB 27 2002
TRADEMARK

T.H.
3-12-02

Docket No. 24278-1
CERTIFICATE OF MAILING

I hereby certify that this paper is being deposited with the United States Postal Service with sufficient postage as first class mail in an envelope addressed to: Commissioner for Patents, Washington, DC 20231 on February 19, 2002

Stephanie R. Berlepsch
Stephanie R. Berlepsch

PATENT
#8/Election
RECEIVED
MAR - 7 2002
TR 3700 MAIL ROOM

IN THE UNITED STATES PATENT & TRADEMARK OFFICE

Applicant: Jack B. Stubbs, et al. : Paper No.:
Serial No.: 09/436,515 : Group Art Unit: 3764
Filed: November 9, 1999 : Examiner: G. E. Richman
For: **Exercise Monitoring System and Methods**

RESPONSE TO RESTRICTION REQUIREMENT

Commissioner for Patents
Washington, DC 20231

Dear Sir:

In response to the Restriction Requirement of December 18, 2001, applications elect claims 1-18 for the purposes of examination at this time. A Petition for Extension of Time is also enclosed herewith. Any questions concerning the foregoing should be directed to the undersigned at 513-977-8565.

Respectfully submitted,

By *Martin J. Miller*
Martin J. Miller
Registration No. 35,953
Attorney for Applicants
DINSMORE & SHOHL LLP
255 East Fifth Street
1900 Chemed Center
Cincinnati, Ohio 45202
(513) 977-8565

762925_1

O I P E J C 1 5 2
FEB 27 2002
PATENT & TRADEMARK OFFICE

Docket No: 24278-1

CERTIFICATE OF MAILING

I hereby certify that this paper is being deposited with the United States Postal Service with sufficient postage as first class mail in an envelope addressed to: Commissioner for Patents, Washington, DC 20231 on February 19, 2002.

Stephanie R. Berlepsch
Stephanie R. Berlepsch

3764
PATENT
RECEIVED
MAR 7 2002
12502
7/EX
05
time
(MOS)

IN THE UNITED STATES PATENT & TRADEMARK OFFICE

Applicant: Jack B. Stubbs, et al. Paper No.:
Serial No.: 09/436,515 Group Art Unit: 3764
Filed: November 9, 1999 Examiner: G. E. Richman
For: **Exercise Monitoring System and Methods**

REQUEST FOR EXTENSION OF TIME

Commissioner for Patents
Washington, DC 20231

Dear Sir:

Submitted herewith is a Response to the Restriction Requirement mailed December 18, 2001.

Applicants petition the Commissioner of Patents & Trademarks to extend the time for response to the Office Action dated December 18, 2001 for one month(s) from January 18, 2002 to February 18, 2002.

Submitted herewith is a check for \$55.00 to cover the cost of the extension. Any deficiency or overpayment should be charged or credited to Deposit Account No. 04-1133.

Respectfully submitted,

By: Martin J. Miller
Martin J. Miller
Registration No. 35,953
Attorney for Applicant(s)
DINSMORE & SHOHL, LLP
1900 Chemed Center
255 East Fifth Street
Cincinnati, Ohio 45202
(513) 977-8565

(MOS)
John Berlepsch

03/05/2002 MAHMED1 00000075 09436515
01 FC:215 55.00 OP



UNITED STATES PATENT AND TRADEMARK OFFICE

UNITED STATES DEPARTMENT OF COMMERCE
United States Patent and Trademark Office
Address: COMMISSIONER OF PATENTS AND TRADEMARKS
Washington, D.C. 20231
www.uspto.gov

APPLICATION NO.	FILING DATE	FIRST NAMED INVENTOR	ATTORNEY DOCKET NO.	CONFIRMATION NO.
09/436,515	11/09/1999	JACK B. STUBBS	24278-1	6756

7590 12/18/2001

DINSMORE AND SHOHL LLP
1900 CHEMED CENTER
255 EAST FIFTH STREET
CINCINNATI, OH 45202

EXAMINER

RICHMAN, GLENN E *#1e*

ART UNIT	PAPER NUMBER
3764	

3764

DATE MAILED: 12/18/2001

Please find below and/or attached an Office communication concerning this application or proceeding.

Office Action Summary

Application No. 09/436,515	Applicant(s) Stubbs et al
Examiner Glenn Richman	Art Unit 3764



-- The MAILING DATE of this communication appears on the cover sheet with the correspondence address --

Period for Reply

A SHORTENED STATUTORY PERIOD FOR REPLY IS SET TO EXPIRE 1 MONTH(S) FROM THE MAILING DATE OF THIS COMMUNICATION.

- Extensions of time may be available under the provisions of 37 CFR 1.136 (a). In no event, however, may a reply be timely filed after SIX (6) MONTHS from the mailing date of this communication.
- If the period for reply specified above is less than thirty (30) days, a reply within the statutory minimum of thirty (30) days will be considered timely.
- If NO period for reply is specified above, the maximum statutory period will apply and will expire SIX (6) MONTHS from the mailing date of this communication.
- Failure to reply within the set or extended period for reply will, by statute, cause the application to become ABANDONED (35 U.S.C. § 133).
- Any reply received by the Office later than three months after the mailing date of this communication, even if timely filed, may reduce any earned patent term adjustment. See 37 CFR 1.704(b).

Status

- 1) Responsive to communication(s) filed on Jul 30, 2001
- 2a) This action is FINAL.
- 2b) This action is non-final.
- 3) Since this application is in condition for allowance except for formal matters, prosecution as to the merits is closed in accordance with the practice under *Ex parte Quayle*, 1935 C.D. 11; 453 O.G. 213.

Disposition of Claims

- 4) Claim(s) 1-58 is/are pending in the application.
 - 4a) Of the above, claim(s) _____ is/are withdrawn from consideration.
- 5) Claim(s) _____ is/are allowed.
- 6) Claim(s) _____ is/are rejected.
- 7) Claim(s) _____ is/are objected to.
- 8) Claims 1-58 are subject to restriction and/or election requirement.

Application Papers

- 9) The specification is objected to by the Examiner.
- 10) The drawing(s) filed on _____ is/are objected to by the Examiner.
- 11) The proposed drawing correction filed on _____ is: a) approved b) disapproved.
- 12) The oath or declaration is objected to by the Examiner.

Priority under 35 U.S.C. § 119

- 13) Acknowledgement is made of a claim for foreign priority under 35 U.S.C. § 119(a)-(d).
 - a) All b) Some* c) None of:
 - 1. Certified copies of the priority documents have been received.
 - 2. Certified copies of the priority documents have been received in Application No. _____
 - 3. Copies of the certified copies of the priority documents have been received in this National Stage application from the International Bureau (PCT Rule 17.2(a)).

*See the attached detailed Office action for a list of the certified copies not received.

- 14) Acknowledgement is made of a claim for domestic priority under 35 U.S.C. § 119(e).

Attachment(s)

- 15) Notice of References Cited (PTO-892)
- 16) Notice of Draftsperson's Patent Drawing Review (PTO-948)
- 17) Information Disclosure Statement(s) (PTO-1449) Paper No(s). _____
- 18) Interview Summary (PTO-413) Paper No(s). _____
- 19) Notice of Informal Patent Application (PTO-152)
- 20) Other:

Art Unit: 3764

1. Restriction to one of the following inventions is required under 35 U.S.C. 121:
 - I. Claims 1-18, drawn to an exercise monitoring system, classified in class 482, subclass 8.
 - II. Claim 19, drawn to a blood monitoring system, classified in class 600, subclass 532.
 - III. Claims 20-58, drawn to a method of controlling a user's blood oxygen level, classified in class 601, subclass 23.

2. The inventions are distinct, each from the other because of the following reasons:

Inventions I and II are related as combination and subcombination. Inventions in this relationship are distinct if it can be shown that (1) the combination as claimed does not require the particulars of the subcombination as claimed for patentability, and (2) that the subcombination has utility by itself or in other combinations (MPEP § 806.05(c)). In the instant case, the combination as claimed does not require the particulars of the subcombination as claimed because it does not require an oximeter. The subcombination has separate utility such as blood monitoring system.

3. Inventions II and III are related as process and apparatus for its practice. The inventions are distinct if it can be shown that either: (1) the process as claimed can be practiced by another materially different apparatus or by hand, or (2) the apparatus as claimed can be used to practice another and materially different process. (MPEP § 806.05(e)). In this case the apparatus as claimed can be used to practice another and materially different process.

Art Unit: 3764

4. Because these inventions are distinct for the reasons given above and have acquired a separate status in the art as shown by their different classification, restriction for examination purposes as indicated is proper.

5. A telephone call was made to Martin Miller on 12/16/01 to request an oral election to the above restriction requirement, but did not result in an election being made.

Applicant is advised that the reply to this requirement to be complete must include an election of the invention to be examined even though the requirement be traversed (37 CFR 1.143).

6. Any inquiry concerning this communication or earlier communications from the examiner should be directed to Glenn Richman whose telephone number is (703)308-3170. The examiner can normally be reached Tuesday through Thursday from 7:30 AM to 6:00 PM Eastern time. The facsimile number for Art Unit 3764 is (703)308-0758. The facsimile number for submitting formal papers to Technology Center 3700 is (703)305-3590.

Any inquiry of a general nature or relating to the status of this application or proceeding should be directed to the Group 3700 receptionist whose telephone number is (703)308-0858 or to Customer Service at (703)306-6789.

gr
December 16, 2001

Glenn Richman
Primary Examiner
AU 3764

Attachment for PTO-948 (Rev. 03/01, or earlier)
6/18/01

The below text replaces the pre-printed text under the heading, "Information on How to Effect Drawing Changes," on the back of the PTO-948 (Rev. 03/01, or earlier) form.

INFORMATION ON HOW TO EFFECT DRAWING CHANGES

1. Correction of Informalities -- 37 CFR 1.85

New corrected drawings must be filed with the changes incorporated therein. Identifying indicia, if provided, should include the title of the invention, inventor's name, and application number, or docket number (if any) if an application number has not been assigned to the application. If this information is provided, it must be placed on the front of each sheet and centered within the top margin. If corrected drawings are required in a Notice of Allowability (PTOL-37), the new drawings **MUST** be filed within the **THREE MONTH** shortened statutory period set for reply in the Notice of Allowability. Extensions of time may **NOT** be obtained under the provisions of 37 CFR 1.136(a) or (b) for filing the corrected drawings after the mailing of a Notice of Allowability. The drawings should be filed as a separate paper with a transmittal letter addressed to the Official Draftsperson.

2. Corrections other than Informalities Noted by Draftsperson on form PTO-948.

All changes to the drawings, other than informalities noted by the Draftsperson, **MUST** be made in the same manner as above except that, normally, a highlighted (preferably red ink) sketch of the changes to be incorporated into the new drawings **MUST** be approved by the examiner before the application will be allowed. No changes will be permitted to be made other than correction of informalities, unless the examiner has approved the proposed changes.

Timing of Corrections

Applicant is required to submit the drawing corrections within the time period set in the attached Office communication. See 37 CFR 1.85(a)

Failure to take corrective action within the set period will result in **ABANDONMENT** of the application.

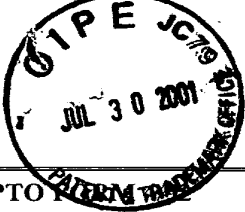

AS

FORM PTO - 1449
LIST OF PATENTS AND PUBLICATIONS
FOR APPLICANT'S INFORMATION
DISCLOSURE STATEMENT

ATTY DOCKET. 24278-1
APPLICANT Stubbs, et al.
FILING DATE November 9, 1999
FOR EXERCISE MONITORING
SYSTEM AND METHODS

SERIAL NO. 09/436,515
GROUP 3661

UNITED STATES LETTERS PATENT

DOCUMENT NUMBER	DATE	NAME	CLASS	SUB CLASS
5 1 4 8 0 0 2	09/15/92	Kuo et al.	TECHNOLOGY CENTER #3700 AUG 6 2001 RECEIVED	1 1 1
6 0 8 3 2 4 8	07/4/00	Thompson		1 1 1
6 1 5 2 8 5 6	11/28/00	Studor et al.		1 1 1

FOREIGN PATENT DOCUMENTS

DOCUMENT NUMBER	DATE	NAME	CLASS	SUB CLASS

RECEIVED
AUG 02 2001
03600 MAIL ROOM

OTHER ART (INCLUDING AUTHOR, TITLE DATE, PERTINENT PAGES, ETC.)

EXAMINER DATE CONSIDERED
EXAMINER: Initial if reference considered, whether or not citation is in conformance with MPEP 609; Draw line through citation if not in conformance and no considered. Include copy of this form with next communication to applicant.

3661

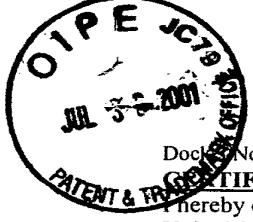

Docket No. 24278-1.

CERTIFICATE OF MAILING

I hereby certify that this paper is being deposited with the United States Postal Service with sufficient postage as first class mail in an envelope addressed to: Assistant Commissioner for Patents, Washington, DC 20231 on July 26, 2001.

Stephanie Berlepsch
Stephanie Berlepsch

RECEIVED
AUG 6 2001
TECHNOLOGY CENTER R3700

PATENT

#5

IN THE UNITED STATES PATENT & TRADEMARK OFFICE

Applicant: Jack B. Stubbs :
Kevin L. Schwieger
Serial No.: 09/436,515 : Group Art Unit: 3661
Filed: November 9, 1999 : Examiner:
For: **EXERCISE MONITORING SYSTEM AND METHODS**

RECEIVED
AUG 02 2001
3600 MAIL ROOM

SUPPLEMENTAL INFORMATION DISCLOSURE STATEMENT

Assistant Commissioner for Patents
Washington, DC 20231

Dear Sir:

In accordance with 37 C.F.R. §§ 1.97 and 1.98 Applicant herewith submits certain patent references which the Patent & Trademark Office may wish to consider in examining the above-identified application. The references are listed on the attached Form PTO-1449. A Certificate under 37 C.F.R. § 197(e) is also enclosed

Copies of the listed references are also provided. No representation is made or intended that a prior art search has been made or that no better art than that listed is available.

Please charge any fees required, or credit any overpayment, to Deposit Account No. 04-1133.

Respectfully submitted,

By Martin J. Miller
Martin J. Miller
Registration No. 35,953
Attorney for Applicants
DINSMORE & SHOHL LLP
1900 Chemed Center
255 East Fifth Street
Cincinnati, OH 45202
(513) 977-8565



Document No. 24278-1.

CERTIFICATE OF MAILING

I hereby certify that this paper is being deposited with the United States Postal Service with sufficient postage as first class mail in an envelope addressed to: Assistant Commissioner for Patents, Washington DC 20231 on July 26, 2001.

Stephanie Berlepsch
Stephanie Berlepsch

RECEIVED
AUG 6 2001
TECHNOLOGY CENTER R3700

PATENT

IN THE UNITED STATES PATENT & TRADEMARK OFFICE

Applicant: Jack B. Stubbs :
Kevin L. Schwieger
Serial No.: 09/436,515 : Group Art Unit: 3661
Filed: November 9, 1999 : Examiner:
For: **EXERCISE MONITORING SYSTEM AND METHODS**

RECEIVED

AUG 02 2001

TO 3600 MAIL ROOM

CERTIFICATE UNDER 37 CFR 1.97(e)

Assistant Commissioner for Patents
Washington, DC 20231

Dear Sir:

I hereby certify that no item of information in the Supplemental Information Disclosure Statement filed herewith was cited in a communication from a foreign patent office in a counterpart foreign application or, to my knowledge after making reasonable inquiry, was known to any individual designated in 37 CFR 1.56(c) more than 3 months prior to the filing of the Supplemental Information Disclosure Statement.

Respectfully submitted,

By Martin J. Miller
Martin J. Miller
Registration No. 35,953
Attorney for Applicants
DINSMORE & SHOHL LLP
1900 Chemed Center
255 East Fifth Street
Cincinnati, OH 45202
(513) 977-8565

699181.01

3661

Docket No. 24278-1.

CERTIFICATE OF MAILING

I hereby certify that this paper is being deposited with the United States Postal Service with sufficient postage as first class mail in an envelope addressed to: Assistant Commissioner for Patents, Washington, DC 20231 on 6/28/00

PATENT

[Handwritten signature]
7/20/01



Jackeline Grant
Jackeline Grant

IN THE UNITED STATES PATENT & TRADEMARK OFFICE

Applicant: Jack B. Stubbs :
Kevin L. Schwieger :
Serial No.: 09/436,515 : Group Art Unit: 3661
Filed: November 9, 1999 : Examiner:
For: **EXERCISE MONITORING SYSTEM AND METHODS**

RECEIVED
JUL -5 2001
TC 3600 MAIL ROOM

INFORMATION DISCLOSURE STATEMENT

Assistant Commissioner for Patents
Washington, DC 20231

Dear Sir:

In accordance with 37 C.F.R. §§ 1.97 and 1.98 Applicant herewith submits certain patent references which the Patent & Trademark Office may wish to consider in examining the above-identified application. The references are listed on the attached Form PTO-1449.

Copies of the listed references are also provided. No representation is made or intended that a prior art search has been made or that no better art than that listed is available.

Please charge any fees required, or credit any overpayment, to Deposit Account No. 04-1133.

Respectfully submitted,

By *John V. Harmeyer*
John V. Harmeyer
Registration No. 41,815
Attorney for Applicant(s)
DINSMORE & SHOHL LLP
1900 Chemed Center
255 East Fifth Street
Cincinnati, OH 45202
(513) 977-8649

RECEIVED
JUL 19 2002
TC 3700 MAIL ROOM

APPLICATION TRANSFER REQUEST FOR S.N. 09/436515

5/18/00

JH

Section I. TRANSFER REQUEST BY (PRINT NAME) Chin Date 5-8-00

TO: Art Unit 2857 Class/sub 702/127+ FROM: A.U. 3661 Class 701

REASON:

Physiological measuring system, yours in 702/127+.

Gatekeeper concurrence 891

Hand carried: Personally accepted by _____

Section II a. DISPOSITION BY RECEIVING TC By: H. Wachman A.U. 2857 Date 5-17-00

ACCEPTED BY RECEIVING T.C.

#B for YN 5/18/00

NOT ACCEPTED

Forward to receiving TC Post Classifier

Non-classification issue/other, return to Originating TC/AU _____

REASON:

Physiological monitoring
Appropriate to 601/23+ AU 3733

Section II b. DISPOSITION BY RECEIVING TC POST CLASSIFIER

This dispute was resolved. Forward to TC/AU 3764 Class/Sub 482/85 Post Classifier _____ Date _____

Concurring T. Sweet Date 6/6/00

This dispute was not resolved, forward to DISPUTE RESOLUTION PANEL

Post Classifier Assessment:

GPS based exercise monitoring device 482/85 -
which tracks physiological effects as well as exercise
parameters. 500/3764

Gatekeeper Concurrence _____

Post Classifier _____

Date _____

Section III. DISPOSITION BY DISPUTE RESOLUTION PANEL

Date _____

Panel Decision: Forward to Technology Center / Art Unit _____ Class/sub _____

REASON:

Panel Member _____ Concurring Panel Member _____

This application MAY NOT be returned to the dispute resolution panel. THIS IS A FINAL DISPOSITION 00294



UNITED STATES DEPARTMENT OF COMMERCE
Patent and Trademark Office
 Address: COMMISSIONER OF PATENTS AND TRADEMARKS
 Washington, D.C. 20231

3

APPLICATION NUMBER	FILING/RECEIPT DATE	FIRST NAMED APPLICANT	ATTORNEY DOCKET NO./TITLE
--------------------	---------------------	-----------------------	---------------------------

09/436,515 11/09/99 STUBBS 24278-1

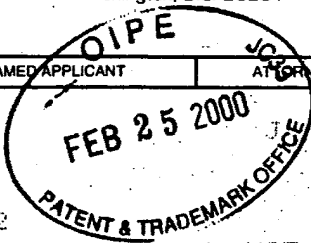

DINSMORE AND SHOHL LLP
 1900 CHEMED CENTER
 255 EAST FIFTH STREET
 CINCINNATI OH 45202

0242/1222

NOT ASSIGNED

3661

DATE MAILED:

12/22/99

NOTICE TO FILE MISSING PARTS OF APPLICATION
Filing Date Granted

An Application Number and Filing Date have been assigned to this application. The items indicated below, however, are missing. Applicant is given TWO MONTHS FROM THE DATE OF THIS NOTICE within which to file all required items and pay any fees required below to avoid abandonment. Extensions of time may be obtained by filing a petition accompanied by the extension fee under the provisions of 37 CFR 1.136(a). If any of items 1 or 3 through 5 are indicated as missing, the SURCHARGE set forth in 37 CFR 1.16(e) of \$65.00 for a small entity in compliance with 37 CFR 1.27, or \$130.00 for a non-small entity, must also be timely submitted in reply to this NOTICE to avoid abandonment.

If all required items on this form are filed within the period set above, the total amount owed by applicant as a small entity (statement filed) non-small entity is \$ 1012.00

- 1. The statutory basic filing fee is:
 - missing.
 - insufficient.
 Applicant must submit \$ 380.00 to complete the basic filing fee and/or file a small entity statement claiming such status (37 CFR 1.27).
- 2. The following additional claims fees are due:
 - \$ 333.00 for 37 total claims over 20.
 - \$ 234.00 for 6 independent claims over 3.
 - \$ _____ for multiple dependent claim surcharge.
 Applicant must either submit the additional claim fees or cancel additional claims for which fees are due.
- 3. The oath or declaration:
 - is missing or unsigned.
 - does not cover the newly submitted items.
 An oath or declaration in compliance with 37 CFR 1.63, including residence information and identifying the application by the above Application Number and Filing Date is required.
- 4. The signature(s) to the oath or declaration is/are by a person other than inventor or person qualified under 37 CFR 1.42, 1.43 or 1.47.
 A properly signed oath or declaration in compliance with 37 CFR 1.63, identifying the application by the above Application Number and Filing Date, is required.
- 5. The signature of the following joint inventor(s) is missing from the oath or declaration:

 An oath or declaration in compliance with 37 CFR 1.63 listing the names of all inventors and signed by the omitted inventor(s), identifying this application by the above Application Number and Filing Date, is required.
- 6. A \$50.00 processing fee is required since your check was returned without payment (37 CFR 1.21(m)).
- 7. Your filing receipt was mailed in error because your check was returned without payment.
- 8. The application was filed in a language other than English.
 Applicant must file a verified English translation of the application, the \$130.00 set forth in 37 CFR 1.17(k), unless previously submitted, and a statement that the translation is accurate (37 CFR 1.52(d)).
- 9. OTHER: _____

Direct the reply and any questions about this notice to "Attention: Box Missing Parts."

E. J. Shearman & Sterling

A copy of this notice MUST be returned with the reply.

Customer Service Center
 Initial Patent Examination Division (703) 308-1202

02/28/2000 NPRASASD 00000111 09436515

01 FC:202 234.00 OP
 02 FC:203 333.00 OP
 03 FC:205 65.00 OP
 04 FC:201 380.00 OP
 05 FC:299

IPR 2018-00294
 U.S. GPO: 1998-448-824

**DINSMORE
& SHOHL LLP**

Attorneys at Law

1900 Chemed Center
255 East Fifth Street
Cincinnati, Ohio 45202
(513) 977-8200
Fax (513) 977-8141

Martin J. Miller, Esq.
(513) 977-8565
e-mail: mmiller@dinslaw.com

Columbus
(614) 628-6880
Fax (614) 628-6890

Covington
(606) 292-2502
Fax (513) 977-8141

Dayton
(937) 449-6400
Fax (937) 449-6405

Lexington
(606) 425-1000
Fax (606) 425-1099

Louisville
(502) 540-2300
Fax (502) 585-2207

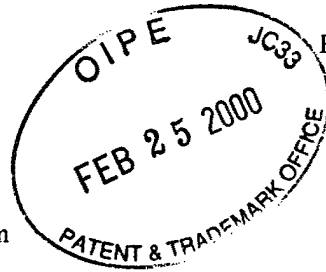

www.dinslaw.com

#3

February 22, 2000

Box Missing Parts
Assistant Commissioner of Patents
Washington, DC 20231

TRANSMITTAL OF MISSING PARTS OF APPLICATION

Dear Sir:

Transmitted herewith for filing are the missing parts for patent application 09/436,515 filed November 9, 1999.

Inventors: Jack B. Stubbs
Kevin L. Schwieger

Title: EXERCISE MONITORING SYSTEM AND METHODS

Papers Enclosed: PTO Form 1533 (*Notice to File Missing Parts of Application Filing Date Granted*); Declaration/Power of Attorney; Recordation Form Cover Sheet, Assignment; and Return Receipt Postcard.

Check: \$1,017.00

The Commissioner of Patents and Trademarks is hereby authorized to charge any additional payment of fees deemed necessary for filing and recordation of these documents, or credit any overpayment, to Dinsmore & Shohl, Account No. 04-1133:

Respectfully submitted,

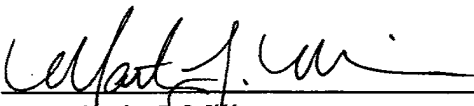
By 

Martin J. Miller
Registration No. 35,953

MJM:jag
Enclosures
Docket No. 24278-1
535527

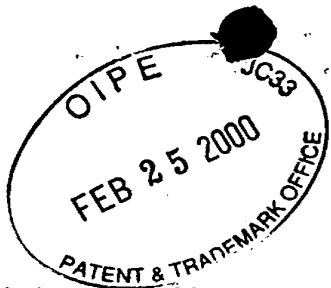

3

DECLARATION
and
POWER OF ATTORNEY

As below named inventors, we hereby declare that:

Our residences, post office addresses and citizenships are as stated below next to our names.

We believe we are the original, first and joint inventors of the subject matter which is claimed and for which a patent is sought on the invention entitled **EXERCISE MONITORING SYSTEM AND METHODS**, the specification of which

[] is attached hereto.

[X] was filed on November 9, 1999 as
Application Serial No. 09/436,515
and was amended on _____
(if applicable)

We hereby state that we have reviewed and understand the contents of the above identified specification, including the claims, as amended by any amendment referred to above.

We acknowledge the duty to disclose information which is material to the examination of this application in accordance with Title 37, Code of Federal Regulations, §1.56(a).

We hereby claim U.S. provisional application or foreign priority benefits under Title 35, United States Code, §119 of any U.S. provisional applications or any foreign application(s) for patent or inventor's certificate listed below and have also identified below any foreign application for patent or inventor's certificate having a filing date before that of the application on which priority is claimed:

Prior U.S. Provisional or Foreign Application(s)				
			Priority Claimed	
Number	Country	Day/Month/Year Filed	Yes	No

We hereby claim the benefit under Title 35, United States Code, §120 of any United States application(s) listed below and, insofar as the subject matter of each of the claims of this application is not disclosed in the prior United States application in the manner provided by the first paragraph of Title 35, United States Code, §112, we acknowledge the duty to disclose material information as defined in Title 37, Code of Federal Regulation, §1.56(a) which occurred between the filing date of the prior application and the national or PCT international filing date of this application:

(Application Serial No.) (Filing Date) (Status)
(patented, pending,
abandoned)

(Application Serial No.) (Filing Date) (Status)
(patented, pending,
abandoned)

We hereby appoint Martin J. Miller, Registration No. 35,953; Holly D. Kozlowski, Registration No. 30,468; Ronald J. Snyder, Registration No. 31,062; James D. Liles, Registration No. 28,320; Lynda E. Roesch, Registration No. 29,696; Phillip A. Rotman II, Registration No. 38,290; Victor C. Moreno, Registration No. 40,732; Jackie A. Zurcher, Registration No. 42,251; John V. Harmeyer, Registration No. 41,815; Scott N. Barker, Registration No. 42,292; and Geoffrey L. Oberhaus, Registration No. 42,955, my attorneys, c/o Dinsmore & Shohl LLP, 1900 Chemed Center, 255 East Fifth Street, Cincinnati, Ohio 45202 (513) 977-8200, with full power in each of them, of substitution and revocation, to prosecute this application and to transact all business in the Patent and Trademark Office connected therewith.

We request that correspondence for this application be directed to Martin J. Miller, Esq. at Dinsmore & Shohl LLP, 1900 Chemed Center, 255 East Fifth Street, Cincinnati, Ohio 45202 (513) 977-8200.

The undersigned hereby authorize the above-named U.S. attorneys to accept and follow instructions from **Paragon Solution, LLC** as to any action to be taken in the Patent and Trademark Office regarding this application without direct communication between the undersigned and the aforementioned U.S. attorneys. In the event of a change in the firm or persons from whom instructions may be taken, the aforementioned U.S. attorneys will be so notified in writing by the undersigned.

We hereby declare that all statements made herein of our own knowledge are true and that all statements made on information and belief are believed to be true; and further that these statements were made with the knowledge that willful false statements and the like so made are punishable by fine or imprisonment, or both, under Section 1001 of Title 18 of the United States Code and that such willful false statements may jeopardize the validity of the application or any patent issued thereon.

Full name of sole or first inventor: Jack B. Stubbs

Inventor's signature Jack B. Stubbs

2/17/00
Date

Residence: Waynesville, Ohio

Citizenship: U.S.

Post Office Address: 4266 Laura Marie Drive, Waynesville, Ohio 45068

Full name of second inventor: Kevin L. Schwieger

Inventor's signature

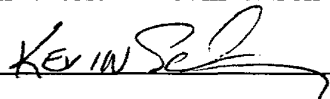

2.17.00

Date

Residence: Lebanon, Ohio

Citizenship: U.S.

Post Office Address: 633 W. Turtle Creek Road, Lebanon, Ohio 45036

500544



UNITED STATES DEPARTMENT OF COMMERCE
Patent and Trademark Office

Address: COMMISSIONER OF PATENTS AND TRADEMARKS
Washington, D.C. 20231

APPLICATION NUMBER	FILING/RECEIPT DATE	FIRST NAMED APPLICANT	ATTORNEY DOCKET NO./TITLE
--------------------	---------------------	-----------------------	---------------------------

09/436,515	11/09/99	STUBBS	J 24278-1
------------	----------	--------	-----------

0242/1222

DINSMORE AND SHOHL LLP
1900 CHEMED CENTER
255 EAST FIFTH STREET
CINCINNATI OH 45202

NOT ASSIGNED

3661

DATE MAILED:

12/22/99

NOTICE TO FILE MISSING PARTS OF APPLICATION
Filing Date Granted

An Application Number and Filing Date have been assigned to this application. The items indicated below, however, are missing. Applicant is given TWO MONTHS FROM THE DATE OF THIS NOTICE within which to file all required items and pay any fees required below to avoid abandonment. Extensions of time may be obtained by filing a petition accompanied by the extension fee under the provisions of 37 CFR 1.136(a). If any of items 1 or 3 through 5 are indicated as missing, the SURCHARGE set forth in 37 CFR 1.16(e) of \$65.00 for a small entity in compliance with 37 CFR 1.27, or \$130.00 for a non-small entity, must also be timely submitted in reply to this NOTICE to avoid abandonment.

If all required items on this form are filed within the period set above, the total amount owed by applicant as a small entity (statement filed) non-small entity is \$ 1012.00

1. The statutory basic filing fee is:
- missing.
 - insufficient.

Applicant must submit \$ 380.00 to complete the basic filing fee and/or file a small entity statement claiming such status (37 CFR 1.27).

2. The following additional claims fees are due:

\$ 333.00 for 37 total claims over 20.

\$ 234.00 for 6 independent claims over 3.

\$ _____ for multiple dependent claim surcharge.

Applicant must either submit the additional claim fees or cancel additional claims for which fees are due.

3. The oath or declaration:

is missing or unsigned.

does not cover the newly submitted items.

An oath or declaration in compliance with 37 CFR 1.63, including residence information and identifying the application by the above Application Number and Filing Date is required.

4. The signature(s) to the oath or declaration is/are by a person other than inventor or person qualified under 37 CFR 1.42, 1.43 or 1.47.

A properly signed oath or declaration in compliance with 37 CFR 1.63, identifying the application by the above Application Number and Filing Date, is required.

5. The signature of the following joint inventor(s) is missing from the oath or declaration:

An oath or declaration in compliance with 37 CFR 1.63 listing the names of all inventors and signed by the omitted inventor(s), identifying this application by the above Application Number and Filing Date, is required.

6. A \$50.00 processing fee is required since your check was returned without payment (37 CFR 1.21(m)).

7. Your filing receipt was mailed in error because your check was returned without payment.

8. The application was filed in a language other than English.

Applicant must file a verified English translation of the application, the \$130.00 set forth in 37 CFR 1.17(k), unless previously submitted, and a statement that the translation is accurate (37 CFR 1.52(d)).

9. OTHER: _____

Direct the reply and any questions about this notice to "Attention: Box Missing Parts."

A copy of this notice MUST be returned with the reply.

Elizabeth Evans

Customer Service Center

Initial Patent Examination Division (703) 308-1202

DINSMORE & SHOHL LLP

11/09/99



Attorneys at Law

1900 Chemed Center
255 East Fifth Street
Cincinnati, Ohio 45202
(513) 977-8200
Fax (513) 977-8141

Martin J. Miller, Esq.
Direct Dial - (513) 977-8565
e-mail: mmiller@dinslaw.com

Columbus
(614) 628-6880
Fax (614) 628-6890

Covington
(606) 292-2502
Fax (513) 977-8141

Dayton
(937) 449-6400
Fax (937) 449-6405

A

Lexington
(606) 425-1000
Fax (606) 425-1099

Louisville
(502) 540-2300
Fax (502) 585-2207

www.dinslaw.com



November 9, 1999

VIA EXPRESS MAIL

BOX PATENT APPLICATION
Assistant Commissioner for Patents
Washington, D.C. 20231

TRANSMITTAL OF PATENT APPLICATION

Dear Sir:

Transmitted herewith for filing is the patent application of:

Inventor(s):	Jack B. Stubbs Kevin L. Schwieger
Title:	EXERCISE MONITORING SYSTEM AND METHODS
Drawings:	<u>12</u> Sheets
Papers Enclosed:	Specification, <u>58</u> Claims and Abstract (Total of <u>59</u> Pages); Verified Statement Claiming Small Entity Status; and Return Receipt Postcard
Attorney Docket No.:	24278-1

Respectfully submitted,
DINSMORE & SHOHL LLP

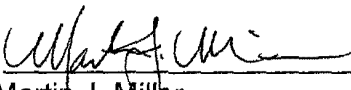
By 
Martin J. Miller
Registration No. 35,953

CERTIFICATE OF EXPRESS MAIL

"Express Mail" mailing label number: EL 441565630US

Date of Deposit: November 9, 1999

I hereby certify that this paper or fee is being deposited with the United States Postal Service "Express Mail Post Office to Addressee" service under 37 CFR 1.10 on the date indicated above and is addressed to Box Patent Application, Assistant Commissioner for Patents, Washington, D. C. 20231

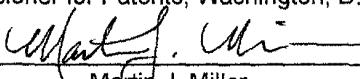
Martin J. Miller

Applicant: Jack B. Stubbs	
Serial No.	Attorney's Docket No.
Filed:	24278-1
For: EXERCISE MONITORING SYSTEM AND METHODS	

**VERIFIED STATEMENT (DECLARATION) CLAIMING SMALL ENTITY
STATUS (37 CFR 1.9(f) and 1.27(c)) - SMALL BUSINESS CONCERN**

I hereby declare that I am

- the owner of the small business concern identified below:
 an official of the small business concern empowered to act on behalf of
the concern identified below:

NAME OF CONCERN Paragon Solutions, LLC
ADDRESS OF CONCERN 4266 Laura Marie Drive
Waynesville, Ohio 45068

I hereby declare that the above identified small business concern qualifies as a small business concern as defined in 13 CFR 121.3-18, and reproduced in 37 CFR 1.9(d), for purposes of paying reduced fees under Section 41(a) and (b) of Title 35, United States Code, in that the number of employees of the concern, including those of its affiliates, does not exceed 500 persons. For purposes of this statement, (1) the number of employees of the business concern is the average over the previous fiscal year of the concern of the persons employed on a full-time, part-time or temporary basis during each of the pay periods of the fiscal year, and (2) concerns are affiliates of each other when either, directly or indirectly, one concern controls or has the power to control the other, or a third party or parties controls or has the power to control both.

I hereby declare that rights under contract or law have been conveyed to and remain with the small business concern identified above with regard to the invention, entitled **EXERCISE MONITORING SYSTEM AND METHODS** by inventor(s) **Jack B. Stubbs** and **Kevin L. Schwieger**.
described in:

- the specification filed herewith
 application Serial No. _____, filed _____

If the rights held by the above identified small business concern are not exclusive, each individual, concern or organization having rights to the invention is listed below* and no rights to the invention are held by any person, other than the inventor, who could not qualify as a small business concern under 37 CFR 1.9(d) or by any concern which would not qualify as a small business concern under 37 CFR 1.9(d) or a nonprofit organization under 37 CFR 1.9(e).

*NOTE: Separate verified statements are required from each named person, concern or organization having rights to the invention averring to their status as small entities. (37 CFR 1.27)

NAME _____

ADDRESS _____

INDIVIDUAL SMALL BUSINESS CONCERN NONPROFIT ORGANIZATION

I acknowledge the duty to file, in this application or patent, notification of any change in status resulting in loss of entitlement to small entity status prior to paying, or at the time of paying, the earliest of the issue fee or any maintenance fee due after the date on which status as a small entity is no longer appropriate (37 CFR 1.28(b)).

I hereby declare that all statements made herein of my own knowledge are true and that all statements made on information and belief are believed to be true; and further that these statements were made with the knowledge that willful false statements and the like so made are punishable by fine or imprisonment, or both, under Section 1001 of Title 18 of the United States Code, and that such willful false statements may jeopardize the validity of the application, any patent issuing thereon, or any patent to which this verified statement is directed.

NAME OF PERSON SIGNING Jack B. Stubbs

TITLE OF PERSON OTHER THAN OWNER CEO / TREASURER

ADDRESS OF PERSON SIGNING 4266 Laurie Marie Drive

Waynesville, Ohio 45068

SIGNATURE *Jack B. Stubbs*

DATE 11/9/99

500570

CERTIFICATE OF EXPRESS MAIL

"Express Mail" mailing label number:

Date of Deposit:

I hereby certify that this paper or fee is being deposited with the United States Postal Service "Express Mail Post Office to Addressee" service under 37 CFR 1.10 on the date indicated above and is addressed to Box Patent Application, Assistant Commissioner for Patents, Washington, D.C. 20231.

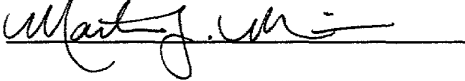

EXERCISE MONITORING SYSTEM AND METHODS

**Jack B. Stubbs
Kevin L. Schwieger**

BACKGROUND OF THE INVENTION

Field of the Invention.

5 The present invention relates to a monitoring system for use in a variety of physical activities, as well as training and analytical methods for physical activities. The present invention provides monitoring systems having an electronic positioning device and/or a physiological monitor (such as an oximeter or a heart rate monitor) in order to provide information concerning a subject performing a physical activity.

Description of Related Art.

10 Throughout the world, more and more people are exercising in order to improve their general health and physical fitness. For the average person, however, a lack of motivation can significantly hinder their efforts. In addition, the natural tendency is to try and achieve the greatest results in the shortest possible time. When typical measurements of physical fitness and progress
15 such as weight loss are monitored, however, expectations often are not met. The result can be a lack of motivation, which in turn leads to a cessation of exercise.

While athletes of all ages are usually able to overcome motivational hurdles, athletes often have difficulty in accurately measuring their progress. Human nature demands instantaneous feedback for motivation and encouragement. In addition, many athletes also do not know how to train effectively for maximal improvement. For example, competitive runners may have difficulty determining whether their pace on a particular day of training is too fast or too slow. While running on a track or treadmill may allow the runner to monitor his or her speed, speed alone is often an inadequate way to monitor optimal training levels.

.5

Currently, there are essentially three methods of providing feedback to individuals engaged in a physical activity. The first, competition, can provide feedback concerning the individual's past training efforts in a particular physical activity. Competition feedback, however, is provided long after the training regimen has been completed, and therefore only allows for adjustments in subsequent training. In addition, many individuals are only interested in improving their general health and physical fitness, rather than competing against others.

10

15

Another method of providing feedback to an individual engaged in a physical activity is heart rate monitoring. Heart rate monitors have become common place in the exercise industry and entire training programs have been developed based upon the data provided by these monitors. Typically, an ECG-type sensor is worn by the individual (such as in a strap which extends about the individual's chest), and heart rate (in beats per minute) is displayed on a wrist-watch type unit. While heart rate monitoring is a useful tool, heart rate data can be difficult to interpret. In addition, many individuals often resort to standardized tables in order to determine target heart rate training zones. Such standardized tables, however, only provide generalized guidelines which may or may not be appropriate for a particular individual or a particular physical activity.

20

25

The third feedback technique which may be used by individuals performing a physical activity is lactate monitoring. Lactate is a byproduct of the anaerobic metabolic process by which energy is produced in the body. The amount of lactate present in an individual's bloodstream provides an indication of their level of exertion. While lactate monitoring can be a valuable tool, it requires drawing blood samples which are analyzed by an expensive, electronic device. Thus, lactate monitoring is invasive, costly, and generally only useful for experienced athletes and their coaches.

BRIEF DESCRIPTION OF THE DRAWINGS

Figure 1 is a schematic illustration of an exercise monitoring system according to one embodiment of the present invention;

Figure 2 is a schematic illustration of an exercise monitoring system according to another embodiment of the present invention;

Figure 3 depicts a human subject performing a physical activity using one embodiment of a monitoring system of the present invention;

Figure 4 is perspective view of the data acquisition component of the monitoring system depicted in Fig. 3;

Figure 5 is a schematic illustration of the monitoring system depicted in Fig. 3;

Figure 6 is an enlarged plan view of a portion of the data acquisition component of the monitoring system depicted in Fig. 3;

Figure 7 is a view similar to Fig. 6, wherein the modules have been removed from the support member of the data acquisition component;

Figure 8 is a perspective view of an oximeter module of the data acquisition component of the monitoring system depicted in Fig. 3;

Figure 9 is a top plan view of the display component of the exercise monitoring system depicted in Fig. 3;

5 Figure 10 is an enlarged top plan view of a portion of the display unit of Fig. 9;

Figure 11 is a rear plan view of a portion of the data acquisition component of Fig. 7;

10 Figure 12 is a cross-sectional view of the data acquisition component of Fig. 7, taken along the line 12-12 thereof;

Figure 13 depicts an alternative display unit according to an embodiment of the exercise monitoring system of the present invention, wherein the display unit is mounted to a handlebar of a bicycle;

15 Figure 14 is a side view of the display unit of Fig. 13, wherein the bicycle handlebar is shown in cross-section;

Figure 15 is a perspective view of an alternative embodiment of a data acquisition component according to the present invention, wherein the data acquisition component is configured to be worn about the chest of a human subject;

20 Figure 16 is a plot which depicts a runner's heart rate and blood oxygen level as the runner's workload is progressively increased;

Figures 17a and 17b are plots depicting a runner's blood oxygen level as the runner's pace is progressively increased;

Figure 18 is a perspective view of an alternative embodiment of an oximeter used in a monitoring system according to the present invention; and

5 Figure 19 depicts an alternative display unit of a monitoring system according to the present invention.

SUMMARY OF THE INVENTION

One embodiment of the present invention is an exercise monitoring system which comprises:

- 10 a. an electronic positioning device;
- b. a physiological monitor; and
- c. a display unit (or component) configured for displaying data provided by the electronic positioning device and the physiological monitor.

15 The electronic positioning device is configured to receive electromagnetic signals from three or more sources so that the monitoring system can determine at least one of a subject's location, altitude, velocity, pace, and distance traveled. In one particular embodiment, the electronic positioning device comprises a GPS device. The physiological monitor may be chosen from the

20 group consisting of: an oximeter and a heart rate monitor.

 The electronic positioning device and the physiological monitor may be provided as part of a user-wearable data acquisition unit (or component) which is separate from the display unit. The data acquisition unit may further include a support member, wherein the electronic positioning device and the

25 physiological monitor are provided on the support member. In one embodiment, the electronic positioning device and the physiological monitor are removably

secured to the support member. The data acquisition unit may be configured to be worn by a subject in a variety of locations, such as the subject's waist or chest. The display unit may likewise be configured in a variety of manners. For example, the display unit may be configured to be worn about a human user's wrist, or may be configured to be mounted to a bicycle (e.g., mounted to the handlebars). The display unit may also comprise an external device to which the monitoring system of the present invention transmits data. For example, the monitoring system of the present invention may be configured to display acquired data on a personal computer ("PC"), and even store the data on the PC for later retrieval and analysis. The monitoring system may also be configured to display data on a treadmill display screen so that the monitoring system will provide blood oxygen data for a subject walking or running on a treadmill.

The physiological monitor of the exercise monitoring system may include a probe (or sensor) configured for acquiring physiological data from a user. The probe may be incorporated into the data acquisition component itself (such as integrally provided on or in the support member), or may comprise a separate unit which is in electrical communication with the data acquisition component (such as by means of a wire or cable, or by means of electromagnetic wave transmission). The monitoring system may further include at least one audible or visual alarms which is activated when data provided by at least one of the electronic positioning device and the physiological monitor does not meet a predetermined target (e.g., when the user's speed, blood oxygen level or heart rate exceeds or falls short of a predetermined target).

Another embodiment of the present invention is an exercise monitoring system which comprises:

- a. an electronic positioning device configured to receive electromagnetic signals from three or more sources so that the monitoring system can determine a subject's velocity or pace;

- b. a display unit configured for displaying data provided by the electronic positioning device; and
- c. an alarm, wherein the alarm is activated when a subject's velocity or pace does not meet a predetermined target.

5 The electronic positioning device in this embodiment may comprise a GPS device.

Yet another embodiment of the present invention is an exercise monitoring system which comprises:

- 10 a. an oximeter configured to determine a subject's blood oxygen level;
- b. a display unit configured for displaying the subject's blood oxygen level; and
- c. an alarm, wherein the alarm is activated when the subject's blood oxygen level does not meet a predetermined target.

15 By way of example, the oximeter may comprise an oximetry probe and oximeter module, which are configured to acquire blood oxygen data by light absorption techniques. Preferably, the oximeters described herein are configured and positioned to determine systemic blood oxygen levels, rather than the blood oxygen level of targeted tissues or regions.

20 Another embodiment of the present invention is a method of controlling a subjects physical activity, comprising:

- a. monitoring a subject's blood oxygen level while the subject performs a physical activity; and
- 25 b. maintaining the blood oxygen level at a selected level while the subject continues to perform the physical activity.

The subject may be human or animal (particularly horses, dogs, camels, and other mammals), and the monitoring step may even utilize the exercise monitoring systems described herein. It should be pointed out, however, that blood oxygen data may also be acquired using conventional, readily-available

oximeters. This method of controlling a subject's physical activity may be performed solely by the subject, or may involve another (such as a coach or trainer). In one particular embodiment, the method of controlling a subject's physical activity even provides a training method for athletes and the like using blood oxygen data.

5

The subject's blood oxygen level may be maintained at the selected level by adjusting the workload of the physical activity as necessary. In fact, the exercise monitoring systems described above may even be used for this purpose, since embodiments of the monitoring system can be configured for computing and displaying the subject's workload (based on the subject's velocity and weight, and optionally based on elevational changes). The subject's blood oxygen level may also be maintained at the selected level by adjusting the subject's level of exertion as necessary. As yet another alternative, the subject's blood oxygen level may be maintained at the selected (or predetermined) level by adjusting the subject's oxygen intake as necessary (e.g., by altering breathing patterns or methods, or by restricting or expanding oxygen or air intake). In fact, by limiting oxygen intake in order to reduce the subject's blood oxygen level, athletic training (e.g., running or biking) at high altitude may be simulated.

10

15

The method of controlling a subject's physical activity is suitable for a variety of activities, including: walking, running, swimming, bicycling, skating, singing, skiing, boating, climbing, wheelchairs, snowshoeing, scuba diving, and flying. The step of monitoring blood oxygen level may comprise:

20

- (a) providing an oximeter, the oximeter including a probe for non-invasively determining blood oxygen level (such as through light absorption measurements); and
- (b) positioning the probe on the subject at a location suitable for detecting the subject's blood oxygen level.

25

Preferably, the probe is positioned such that the oximeter determines the subject's systemic blood oxygen level. The probe location may be chosen from

the group consisting of the subject's back (particularly the subject's lower back), head, arm, leg, chest and torso.

5 It should be noted that the selected (or predetermined) blood oxygen level may comprise a range or a target "setpoint". In fact, multiple predetermined blood oxygen levels may be employed, such that the subject's blood oxygen level is sequentially maintained at multiple selected levels (i.e., interval training). The subject's blood oxygen level may be maintained at each selected level:

- (a) for a predetermined period of time;
- (b) until the subject has advanced a predetermined distance (e.g., as measured by a GPS system); or
- 10 (d) until the subject has performed a predetermined amount of work (e.g., as measured by a GPS system).

Each selected (or predetermined) blood oxygen level may be chosen on the basis of blood oxygen data previously obtained while the subject performed a physical activity. For example, the subject's blood oxygen level at a lactate threshold ("LT") may be determined. Thereafter, each selected blood oxygen level may be chosen on the basis of the subject's LT (e.g., at LT, or a predetermined percentage of LT). Alternatively, each selected level may be chosen on the basis of the duration of the physical activity. For example, the selected blood oxygen level may be higher when the duration of the activity is greater.

25 In order to facilitate the method of controlling the subject's performance of a physical activity, an alarm may be provided. The alarm may be configured to indicate (i.e., provide an audible and/or visible indicia) when the subject's blood oxygen level is not at the selected level (e.g., outside of a selected range, or not within a certain percentage of a setpoint). A display unit configured for displaying the subject's blood oxygen level may also be provided in order to facilitate performance of the method of controlling. When the subject is a human, the display unit may be configured to display blood oxygen data to the

subject or to another (such as a coach or trainer monitoring the subject's performance). For animal subjects, the display unit may be configured to display blood oxygen data to an individual such as a trainer or, in the case of horses and camels, a jockey.

5 It will be appreciated that the exercise monitoring systems of the present invention may be used for the methods of controlling a subject's performance of a physical activity described herein. In fact, the subject's velocity, pace, workload, and/or distance traveled may be measured by an electronic positioning device provided on the exercise monitoring system.

10 Still another embodiment of the present invention comprises a method of reducing a subject's blood oxygen level variability while the subject performs a physical activity, comprising:

- a. periodically measuring a subject's blood oxygen level while the subject performs a physical activity; and
- 15 b. adjusting the manner in which the physical activity is performed in order to reduce blood oxygen level variability.

The time variability of the subject's blood oxygen level may also be indicated (e.g., displayed) to the subject. The time variability of blood oxygen level may be quantified in a variety of manners, such as the standard deviation of the
20 subject's blood oxygen level. The monitoring systems of the present invention may even be configured to activate an alarm when the time variability exceeds a predetermined level.

A method of determining a fitness indicator of a subject is also provided, wherein this method comprises:

- 25 (a) recording a subject's blood oxygen level while the subject performs a physical activity;

- (b) varying the subject's workload (e.g., periodically increasing workload) while continuing to record the subject's blood oxygen level; and
- (c) determining a fitness indicator of the subject on the basis of the recorded blood oxygen data.

5

The fitness indicator may comprise, for example, the subject's lactate threshold or VO₂max (the milliliters of oxygen consumed per kilogram of body weight per minute). The subject's velocity (and optionally altitude) may be measured by a GPS device, such that the subject's workload may then be determined using velocity (and optionally altitude) measurements provided by the GPS device.

10

A method of stabilizing blood oxygen levels while exercising is also provided, and comprises:

- (a) monitoring the level of blood oxygen while exercising;
- (b) adjusting breathing while continuing to exercise in order to stabilize the level of blood oxygen.

15

Another embodiment of the present invention comprises a method of comparing a subject's physical fitness to their physical fitness on a previous occasion, comprising:

- (a) measuring an individual's blood oxygen level while the individual performs a physical activity at a predetermined workload, velocity or pace; and
- (b) measuring the individual's blood oxygen level on a subsequent occasion while the individual performs the physical activity (particularly at the same predetermined workload, velocity or pace).

20

25

For example, if the subject's blood oxygen level (e.g., the subject's average blood oxygen level) is higher on a subsequent occasion, the subject's fitness will have been improved.

DETAILED DESCRIPTION OF THE PREFERRED EMBODIMENTS

The present invention provides an exercise monitoring system, as well as training and analytical methods useful for subjects (both human and animal) performing physical activities. The systems and methods of the present invention, for example, provide real-time data and feedback useful to individuals performing a physical activity (such as athletes). The monitoring system may include an electronic positioning device (such as a GPS device) and/or a physiological monitor (such as an oximeter or a heart rate monitor).

The electronic positioning device uses electromagnetic signals from three or more sources in order to provide data indicative of one or more of the subject's location, altitude, velocity, pace and/or distance traveled. By way of example, the electronic positioning component may comprise a GPS device which utilizes signals from satellites of the Global Positioning System (i.e., "GPS") in order to provide real-time data concerning at least one of the subject's location, altitude, heading, velocity, pace and distance traveled, and may optionally provide a precise time measurement.

The physiological monitor may comprise an oximeter which measures the subject's blood oxygen level, and may also measure the subject's heart rate. Alternatively, the physiological monitor may comprise a heart rate monitor which measures the subject's heart rate.

One embodiment of the monitoring system of the present invention includes both an electronic positioning device and a physiological monitor (such as an oximeter or heart rate monitor) as part of an integrated monitoring system. Such an integrated monitoring system allows velocity, pace, and/or distance traveled information provided by the electronic positioning device to be used in conjunction with data provided by the physiological monitor. In this manner,

exercising subjects can monitor, control and/or analyze their performance while exercising at any location (e.g., outside of a laboratory).

5 The present invention also provides analytical and training methods which utilize data provided by: (a) a physiological monitor; (b) an electronic positioning device (such as a GPS device); or (c) the combination of an electronic positioning device and a physiological monitor (such as a heart rate monitor or an oximeter). It should be pointed out that the various analytical and training methods of the present invention do not require the use of the exercise monitoring systems of the present invention. However, the exercise monitoring systems of the present invention may be configured for implementation of the analytical and training methods described herein.

10 The monitoring systems, as well as the analytical and training methods, provided by the present invention may be used on both human and animal subjects. Hence, the term "subject" is intended to encompass both humans and animals. By way of example, embodiments of the exercise monitoring systems of the present invention may be used for the testing and/or training of horses and other animals typically involved in racing sports (including dogs and camels). Of course, these methods can also be used in the testing and/or training of other animals not necessarily involved in racing sports (such as rehabilitating an injured animal by putting the injured animal through a training program).

15 Figure 1 is a schematic illustration of one embodiment of an exercise monitoring system according to the present invention. The system of Fig. 1 generally comprises an electronic positioning device 5 and a physiological monitor 6, both of which are in electrical communication with a display unit 7. Electronic positioning device 5 is configured to receive electromagnetic signals from three or more sources so that the monitoring system can determine (and display by means of display unit 5) at least one of a subject's location, altitude,

heading, velocity, pace, and distance traveled. By way of example, electronic positioning device 5 may be configured to receive electromagnetic signals, and process those signals in order to determine at least one of a subject's location, altitude, heading, velocity, pace, and distance traveled. The determined data may then be transmitted to display unit 7 for display to the subject or other individual monitoring the subject's performance of a physical activity. Similarly, physiological monitor 6 is configured to acquire physiological data from the subject for display by means of display unit 5. By way of example, physiological monitor 6 may be configured to determine one or more physiological indicia (such as the subject's blood oxygen level or heart rate). The determined physiological indicia may then be transmitted to display unit 7 for display to the subject or other individual monitoring the subject's performance of a physical activity.

Figure 2 schematically depicts a more specific embodiment of an exercise monitoring system according to the present invention. In the embodiment of Fig. 2, electronic positioning device 5 comprises a GPS device which includes a GPS antenna 80, and a GPS module 30. Physiological monitor 6 comprises an oximeter which includes a probe 41, and an oximeter module 40. Display unit 7 may comprise any of a variety of structures configured for displaying data. For example, a simple display unit may include a screen which displays the subject's speed (e.g., in miles per hour) and blood oxygen level (e.g., in terms of the percentage of oxygen saturation). The display unit may optionally be configured for linking to (e.g., in electrical communication with) a computer 8 (such as a personal computer of "PC"). Such linking may be provided by a cable, in infrared link, or other means well-known to those skilled in the art. In this manner, data may be stored in computer 8 for later retrieval and analysis.

An exercise monitoring system according to the present invention may comprise a single structure, or may be subdivided into one or more component structures. Thus, one embodiment of the present invention includes a data

acquisition component and a separate data display component (i.e., display unit) which are in electrical communication with each other through a wired link (e.g., and electrical cable) or a wireless link (e.g., via radio wave transmission). The data acquisition component may include at least one of an electronic positioning device and a physiological monitor, and may be configured to be worn by a subject performing a physical activity.

A variety of configurations may be provided for the data acquisition component, depending in part upon the nature of the physical activity to be performed as well as the type of data to be acquired. For example, a physiological monitor will often include a sensor or probe which interacts with the subject to acquire physiological data (such as heart rate and/or blood oxygen level). The physiological sensor or probe may be incorporated into the data acquisition component, or may be provided as a separate unit which is in communication with the data acquisition component. For example, the physiological sensor or probe may be remote from the data acquisition component, yet in electrical communication with the data acquisition component over a wired or wireless connection (see, e.g., Fig. 18). When the sensor or probe is incorporated into the data acquisition component itself, the data acquisition component may be configured to ensure proper positioning of the sensor or probe on the subject (i.e., in a position operable to acquire the desired physiological data). Of course, the data acquisition component of a monitoring system according to the present invention may even comprise multiple structures which are physically separate from each other.

The data display component may likewise be provided in a variety of configurations, and its configuration may even be chosen based upon the particular physical activity to be performed. By way of example, the display component may be worn by the subject, worn by another individual, attached to an apparatus associated with the physical activity (e.g., mounted on a bicycle), or provided as a separate, standalone unit.

Figure 3 depicts a human subject performing a physical activity, namely running, using a monitoring system according to one embodiment of the present invention. In the monitoring system depicted in Fig. 3, the data acquisition component is depicted at 20, and is worn about the subject's waist. The data display component is depicted at 7, and is worn about the subject's wrist. While the system shown in Fig. 3 provides separate data acquisition and data display components, it will be understood that these two components can be provided in a single structure. In addition, the configuration of data acquisition component 20 and data display component 7 in Fig. 3 is merely exemplary of one embodiment of a monitoring system according to the present invention. The structural features of the specific embodiment of the monitoring system of Fig. 3 will be further described below, after the electronic configuration has been described.

As mentioned previously, the data acquisition component of the monitoring system of the present invention may include an electronic positioning device and/or a physiological monitor (such as an oximeter or a heart rate monitor). In the schematic illustration of an exemplary monitoring system in Fig. 5, data acquisition component 20 includes both an electronic positioning device and a physiological monitor. In the embodiment of Fig. 5, the electronic positioning device comprises a GPS device which may include a GPS antenna 80 and a GPS processing module 30. As further detailed below, antenna 80 receives GPS satellite signals, and signal output from antenna 80 is processed by GPS processing module 30 in order to provide an electrical signal which includes, for example, data indicative of the user's location. Data from GPS module 30 is provided to processor/transmitter module 60 where it may be further processed and then transmitted to display component 7 over link 64.

It should be noted that the electronic positioning device used in embodiments of the monitoring system of the present invention is not limited to a GPS device. Thus, the term electronic positioning device is intended to be

inclusive of devices which receive electromagnetic signals from three or more sources, and thereafter process those signals in order to provide data indicative at least one of the subject's location, altitude, heading, velocity, pace and distance traveled. For example, an electronic positioning device which detects radio wave and/or microwave signals from at least three sources may be used, wherein the received signals are processed in a manner similar to the processing of GPS signals in order to determine the subject's location, altitude, heading, velocity, pace and/or distance traveled. Even signals from cellular phone towers may be employed. In addition, the term "GPS device" is intended to include devices which utilize signals received from satellites of the Global Positioning System developed by the United States Department of Defense, as well as systems which utilize signals received from satellites of the Global Orbiting Navigation Satellite System ("GLONASS") developed by the former Soviet Union (or any other satellite-based positioning system which receives and processes electromagnetic signals from three or more satellites).

Data acquisition component 20 of Fig. 5 also includes a physiological monitor; in this case an oximeter which may include an oximetry probe 41 and an oximeter module 40. Probe 41 acquires data indicative of the subject's blood oxygen level (and optionally heart rate), and oximeter module 40 processes data received from probe 41 in order to provide an electrical signal which includes data indicative of the subject's blood oxygen level (and optionally data indicative of the subject's heart rate). Blood oxygen data from oximeter module 30 is provided to processor/transmitter module 60 where it may be further processed and then transmitted to display component 7 over link 64. Data acquisition component 20 also includes a power supply 25 which provides electrical power to GPS module 30, oximeter module 40, probe 41, and processor/transmitter 60, as needed. GPS antenna 80 may also receive electrical power from power supply 25 when an active GPS antenna is used.

It will be understood that the physiological monitor used in embodiments of the monitoring system of the present invention is not limited to an oximeter. The physiological monitor may alternatively comprise, for example, a heart rate monitor which may include a heart rate module and associated sensor or probe for acquiring data indicative of the subject's heart rate. The data acquired by a heart rate monitor sensor or probe is processed in the heart rate module in order to provide data indicative of the subject's heart rate to processor/ transmitter module 60 for further processing and transmittal to display component 7 over link 64.

Processor/transmitter module 60 may include a processor 66 which processes data received from oximeter module 40 and GPS module 30 in accordance with instructions stored in memory 67. The data is thereafter transmitted to display component 7 by a wired or wireless link 64. Thus, electronic link 64 may merely comprise one or more electrical cables or wires located between processor 66 and display component 7 (see. e.g., Fig. 19). Alternatively, data may be transmitted by a wireless link using, for example, radio waves. Thus, in the embodiment of Fig. 5, processor/transmitter module 60 includes an RF transmitter 65 which transmits data received from processor 66 via radio waves to receiver 76 of display component 7.

As mentioned above, display component 7 includes a receiver 76 for receiving data transmitted by data acquisition component 20. The received data may include, for example, data indicative of the subject's location, altitude, heading, velocity, pace, distance traveled, blood oxygen level and/or heart rate, (and optionally the current time as determined by the GPS device). This data is then provided to processor 75 wherein it may be further processed in accordance with instructions stored in memory 77. After processing, acquired and/or calculated data is displayed on display screen 52 where it is visible to the subject or an individual monitoring the subject's performance. Display component 7 may also include a power supply 78 for supplying power to

processor 75, receiver 76, and other components, as necessary, within display component 7.

5 It should be noted that transmitter 65 and receiver 76 may alternatively each comprise transceivers so that electrical signals may be transmitted in both directions (i.e., from data acquisition component 20 to display component 7, and from display component 7 to data acquisition component 20).

10 Display component 7 may also include one or more alarms 79, each of which provides an audible and/or visual alarm in response to a signal received from processor 75. A plurality of input devices may also be provided on display component 7 so that the subject or other individual may control the processing and/or display of acquired data on display screen 52. Such input devices may comprise, for example, input switches 53–56. Display component 7 may further include a peripheral interface 85 which allows display component 7 to be linked to an external device such that data may be transmitted from display component 15 7 to the external device (such as a PC, as described previously). In this manner, data concerning the subject's performance of a physical activity may be stored for further processing, analysis and/or retrieval. Peripheral interface 85 may be configured in a variety of manners, depending upon the type of connection to the external device (such as a PC). For example, data may be transmitted from display component 20 7 to a PC over a wired link. Thus, peripheral interface 85 may merely comprise an electrical terminal to which one end of a cable may be attached. The other end of the cable may then be attached to the PC, such as through a USB port or a serial port. Alternatively, display component 7 may transmit data by means of a wireless link, such as by radio waves or infrared. 25 Thus, peripheral interface 85 may also include a transmitter capable of transmitting radio waves or an infrared signal to a PC which is configured to receive radio waves or an infrared signal. A variety of other structures well-known to those skilled in the art may also be used for peripheral interface 85 in order to transmit data to a PC or other external device.

Electronic Positioning Device

As mentioned above, one embodiment of the monitoring system of the present invention includes an electronic positioning device which determines the subject's location, altitude, heading, velocity, pace, and/or distance traveled based upon electromagnetic signals received from three or more sources. While other positioning devices may be employed, one embodiment of the monitoring system of the present invention employs a GPS device. In general, the GPS device receives electromagnetic signals from three or more satellites, and computes the user's location based upon those signals. In essence, each satellite signal provides the three-dimensional location of the satellite at a precise time. The GPS device then computes the time it took for each signal to reach the GPS device, and this data is then used to compute the user's precise location (typically in terms of the user's longitude and latitude at the time of receiving the GPS satellite signals, and optionally the user's altitude).

The GPS device may generally include an antenna (an active or passive antenna) and a GPS processing module, as previously described. The antenna receives GPS signals from three or more orbiting satellites and transmits the acquired data to the GPS processing module. Thus, as shown in Fig. 5 which is a schematic illustration of one embodiment of the present invention, GPS antenna 80 is in electrical communication with GPS processing module 30, and therefore transmits data acquired from three or more GPS satellites to GPS module 30. It should be noted that while GPS antenna 80 and GPS module 30 are depicted as separate units, they may alternatively be combined into a single structure. GPS processing module 30 then computes the precise location of the subject, and may provide an electrical signal indicative of this position (e.g., in terms of latitude, longitude, and altitude) to processor/transmitter module 60 for further processing.

While GPS processing module 30 may merely transmit raw data indicative of the subject's position to processor/transmitter module 60, GPS module 30 may alternatively process the location data in order to compute, and provide an electrical signal indicative of the subject's velocity, heading, pace and/or distance traveled, as well as the current time. The computed data may then be transmitted to module 60 for further processing and transmittal to display component 7. Of course, it will be understood that, depending upon the level of processing provided by GPS module 30, processor/transmitter module 60 may simply receive data from GPS module 30 and pass the data substantially unaltered to display component 7 via link 64. Thereafter, the transmitted data may be further processed within display component 7, as needed, so as to provide additional data such as average velocity, average pace, workload (based on the subject's weight) and/or other useful information as desired.

in order to compute the distance traveled, a "start point" must be provided to the monitoring system. If the distance traveled is computed by GPS module 30 or processor 66 of processor/ transmitter module 60, the subject's location when data acquisition component 20 is first powered up may be selected as the start point for purposes of calculating the distance traveled. Alternatively, an input device may be provided on data acquisition component 20 in order to commence calculation of the subject's distance traveled. If transmitter 65 of processor/transmitter module 60 is replaced by a transceiver, data acquisition component 20 may also receive a start point signal from display component 7. In this manner, the subject may input a start point (such as by pressing a start button or switch) provided on display component 7 in order to commence calculation of the subject's distance traveled. As yet another alternative, the subject's distance traveled may be computed in processor 75 provided in display component 7, thus alleviating the need to provide a start point signal to data acquisition component 20.

In order to provide the above-described functionality, the GPS device utilized in embodiments of the present invention may employ conventional, commercially-available components. As described in U.S. Patent No. 5,627,548 which is incorporated herein by way of reference, an integrated circuit (IC) may be used in GPS module 30, wherein the IC includes, for example, a low-noise amplifier for boosting signals received from the GPS antenna, a downconverter for translating the amplified signals to a more suitable frequency, and one or more processors (such as a code-processor and a navigation processor). Numerous manufacturers provide both GPS antennas, as well as GPS “receivers”, the latter of which may be incorporated into GPS module 30 of the present invention. Commercially-available GPS receivers generally comprise a circuit board having thereon one or more microprocessor units, one or more custom integrated circuits, software, and other electronic componentry necessary for performing GPS functions. The GPS antenna (also commercially-available) is merely operatively connected to the GPS module (such as by way of a coaxial cable, or other wired or wireless link). A power supply is also operatively connected to the GPS module. The GPS module will then provide (such as through a suitable electronic connector) an electrical signal which includes data indicative of, for example, the subject’s latitude, longitude, altitude, velocity and/or heading, as well the current time (the latter based upon the received satellite signals). Therefore, GPS module 30 may simply comprise a commercially-available GPS receiver, along with suitable connection elements which allow GPS antenna 80, power supply 25, and processor/transmitter module 60 to be operatively connected to the GPS receiver portion of GPS module 30.

One commercially-available GPS receiver which may be used in an embodiment of the present invention is the GPS-PS1 receiver available from μ -blox AG, of Zurich, Switzerland. Alternatively, the GPS-MS1 receiver (also available from μ -blox AG) may be used. Suitable GPS antennas are also available from μ -blox AG, as well as other sources.

While some commercially-available GPS systems simply display the user's location (typically in terms of longitude and latitude values, and optionally altitude), as mentioned previously, an embodiment of the present invention utilizes GPS location data for computing velocity, pace and/or distance traveled.

5 Thus, the GPS device used in embodiments of the present invention may acquire location information at predetermined intervals, such as between about 0.1 and about 1.0 seconds. In this manner, the GPS device is capable of periodically determining the subject's location (e.g., determining the subject's location between about every tenth of a second and about every second). Such

10 periodic location data can then be further processed (such as in the GPS module, or alternatively in processor/transmitter module 60, or even in processor 75 of display component 7) in order to compute the subject's velocity (e.g., speed in miles per hour), pace (e.g., the user's speed in terms of the number of minutes to complete one mile), or distance traveled (e.g., the distance that the user has traveled since an initial start point). The commercially-available GPS receivers mentioned above are generally configured for computing velocity, and may be readily programmed to compute pace and/or distance traveled. In this manner, these commercially-available GPS receivers may be incorporated into GPS module 30 such that GPS module 30 will provide a signal which includes

15 data indicative of the subject's latitude, longitude, altitude, velocity, heading, pace and/or distance traveled (as well as the current time).

20

An embodiment of the monitoring system of the present invention which includes an electronic positioning device is useful even without the inclusion of a physiological monitor. For example, an individual can use the GPS device of

25 the monitoring system while running (or performing any other physical activity) in order to determine their velocity at any given moment (e.g., in miles per hour), their pace at any given moment (e.g., in terms of minutes per mile), and/or the total distance they have run since an initial start time (e.g., from the moment they begin running).

When the monitoring system includes both an electronic positioning device (such as a GPS device) and a physiological monitor (such as an oximeter or heart rate monitor), data provided by the GPS system may be used in conjunction with the physiological data for performance monitoring, testing and/or training. By way of example, a heart rate monitor device incorporated into a monitoring system according to the present invention may display a subject's heart rate at any given moment, while a GPS device of the system simultaneously displays the subject's velocity and/or pace. In this manner, the subject (or another individual such as a coach or trainer) can more effectively monitor the subject's performance, exertion level and/or progress. By itself, a runner's velocity (or pace) is a poor indicator of performance and/or progress (i.e., improvement). Likewise, heart rate alone is a poor indicator of performance and/or progress when the subject's velocity (or pace) is not known. Simultaneously monitoring velocity (or pace) and heart rate (and/or blood oxygen level), however, provides the missing link; i.e., the physiological effect of running at a certain speed. Thus, incorporating an electronic positioning device and a physiological monitor into an integrated system provides more meaningful data.

Oximeter

As blood is pumped through the lungs, deoxyhemoglobin in the bloodstream absorbs oxygen to become oxyhemoglobin. Thereafter, the oxygenated blood is delivered throughout the body, where the oxygen is released in order to support metabolic function. Medical personnel often monitor a patient's blood oxygen level as one indicator of the patient's overall condition. For example, a patient's blood oxygen level is typically monitored during surgery in order to ensure that sufficient oxygen is reaching the patient's brain and other vital organs.

Blood oxygen levels are typically monitored in terms of the oxygen saturation level, which is defined as the amount of oxyhemoglobin as a percentage of the total hemoglobin. For example, the typical oxygen saturation level of a healthy adult at rest is between about 96% and about 98%, which simply means that between about 96% and about 98% of the hemoglobin in the arterial blood is oxygenated (i.e., converted to oxyhemoglobin). As used herein, the term oximeter includes any device capable of determining blood oxygen level.

Many commercially-available oximeters employ light absorption measurements to determine blood oxygen levels, as well as heart rate. When light is directed towards a volume of blood (such blood in an artery), a portion of the light is absorbed by surrounding tissue as well as the blood. A sensor may then detect the amount of light which is transmitted through or reflected by the blood and surrounding tissue (i.e., light which is not absorbed by the blood or surrounding tissue). During systole, the volume of blood in the artery is increased, and more light will be absorbed by the blood. During diastole, the volume of blood in the artery decreases, and in turn the amount of light absorption decreases. Since light absorption by the surrounding tissue remains constant, the amount of light absorption will vary as a function of heart rate. Therefore, the subject's heart rate can be readily determined simply by monitoring the amount of light absorption (e.g., by measuring the length of time between peak levels of light absorption).

Oxyhemoglobin and deoxyhemoglobin differ in their absorption of light, and these differences in light absorption properties can be employed to determine the blood oxygen level. By measuring light absorption at two or more different wavelengths, blood oxygen level can be readily determined. For example, deoxyhemoglobin absorbs more red light than does oxyhemoglobin, while oxyhemoglobin absorbs more infrared light than deoxyhemoglobin. Since the absorption properties of oxyhemoglobin and deoxyhemoglobin are well-

known, the ratio of oxyhemoglobin to total hemoglobin can be readily determined merely by measuring light absorption at a red wavelength and at an infrared wavelength. The ratio of light absorption at the two frequencies (e.g., red light absorption divided by infrared light absorption) can be compared to values in a look-up table in order to provide a measurement of blood oxygen level.

5

Typically, an oximeter directs light of two different predetermined wavelengths in alternating fashion towards a volume of blood, and a light sensor detects light which is transmitted through or reflected by the blood. Data acquired by the light sensor is then processed in order to provide a measure of the oxygen level of the blood. In the embodiment depicted schematically in Fig. 5, a probe 41 may include a pair of light sources for directing light of two different wavelengths at a volume of blood, as well as a light sensor for detecting light which is transmitted through or reflected by the blood. By way of example, the light sources (such as LED's) may be configured to emit red light (e.g., a wavelength of between about 610 nm and about 650 nm) and infrared light (e.g., a wavelength of between about 810 nm and about 850 nm). Probe 41 is in electronic communication with oximeter module 40 via a wired or wireless connection, such that probe 41 transmits data indicative of detected light to module 40. Oximeter module 40 includes a processor and other electronic componentry which provides an electrical signal indicative of the subject's blood oxygen level, and optionally the subject's heart rate. Oximeter module 40 is in electrical communication with processor/transmitter module 60, such that the electrical signal indicative of the subject's blood oxygen level (and optionally heart rate) is transmitted to processor 66. After processing, processor/transmitter module 60 may transmit the resulting oximetry data to display component 7, as previously described. Alternatively, the oximetry data from oximeter module 40 may be merely transmitted to display component 7 by processor/transmitter module 60.

10

15

20

25

The oximeter device utilized in embodiments of the present invention may employ commercially-available components in order to provide the functionality described above. For example, numerous manufacturers provide both oximeter probes, as well as oximeter modules which may be used in the present invention. Commercially-available oximeter modules are provided, for example, as integrated circuits which may include one or more microprocessors, software, and other electronic componentry for generating an electrical signal which includes data indicative of the subject's blood oxygen level and heart rate. The oximeter probe (also commercially-available) is merely operatively connected to the oximeter module (such as by way of a wired or wireless connection), and the oximeter module will then provide an electrical signal which includes data indicative of the subject's blood oxygen level and heart rate. A commercially-available oximeter module may be repackaged into an enclosed unit suitable for attachment to a support member (such as a belt to be worn by the subject) in electrical communication with the other elements of data acquisition component 20. One commercially-available oximeter module which may be used in an embodiment of the present invention is the OEM2 Pulse Oximeter Module available from Nonin Medical, Inc. of Plymouth, Minnesota. Suitable oximeter probes are also available from Nonin Medical, Inc., as well as other sources.

It should be noted that the monitoring systems of the present invention preferably determine, and the analytical and training methods preferably utilize, the subject's systemic blood oxygen level, rather than localized oxygen levels (such as in or near active muscle tissue). When a subject performs a physical activity, particularly a strenuous activity, blood oxygen level within and around working muscles may vary considerably from the subject's systemic blood oxygen level (i.e., the level of oxygen in the bloodstream as a whole). Thus, the monitoring systems according to the present invention are preferably configured in order to minimize any localized variance in blood oxygen levels as compared to the subject's systemic blood oxygen level. This may be accomplished, for

example, by positioning the oximetry probe in a location of minimal muscle activity, thereby avoiding active muscle tissues or regions.

Heart Rate Monitor

As mentioned previously, the physiological monitor used in certain
5 embodiments of the present invention may comprise a heart rate monitoring
device which provides data indicative of the subject's heart rate. By way of
example, oximeter module 40 in Fig. 5 may merely be replaced by a heart rate
module which processes data received from probe 41 in order to provide an
electrical signal which includes data indicative of the subject's heart rate. In fact,
10 a heart rate module similar in configuration to oximeter module 40 may be
employed, except that the electronic componentry need not be configured for
determining the subject's blood oxygen level. In addition, probe 41 may be used
with a heart rate module, since, as described previously, the light absorption of
blood will vary with the subject's heart rate. During systole, the volume of blood
15 in an artery increases, thereby resulting in a detectable increase in light
absorption. Thus, the subject's heart rate may be readily determined, for
example, by measuring the period of time between light absorption peaks (i.e.,
peaks corresponding to systole). It should be pointed out, however, that light of
a single wave length is sufficient for monitoring the subject's heart rate.
20 Therefore, only a single light source is required in probe 41 if oximeter module
40 is replaced by a heart rate module.

As an alternative to employing light absorption measurements for
determining heart rate, electrocardiography ("ECG") may be employed. A
beating heart produces electrical pulses which can be readily measured in a
25 variety of manners well-known to those skilled in the art. For example, a pair of
electrodes may be positioned against the subject's chest in the region
surrounding the heart, such that the electrodes will detect ECG signals. Thus,
probe 41 may be replaced by an ECG-type probe having a pair of electrodes

suitable for detecting ECG signals and transmitting data indicative of the subject's heart rate to a heart rate module. By way of example, U.S. Patent No. 5,491,474, which is incorporated herein by way of reference, discloses a telemetric transmitter unit which may be used as a heart rate sensor or probe in
5 embodiments of the present invention. The telemetric transmitter unit of this patent is configured to be worn about the subject's chest such that the electrodes of the transmitter unit are operatively positioned so as to detect ECG signals. As described in U.S. Patent No. 5,840,039, which is also incorporated
10 herein by way of reference, data indicative of the subject's heart rate may be transmitted by the telemetric transmitter unit to a telemetric receiver unit. In the present invention, the telemetric receiver unit may simply comprise the heart rate module provided by data acquisition units 20. Alternatively, data from the telemetric transmitter unit may be transmitted directly to data display component
15 7 of the present invention, such as by the methods of U.S. Patent No. 5,840,039. The transmitted heart rate data may then be further processed by data display component 7, as desired. Of course, it is also contemplated that instead of the wireless data transmission described in U.S. Patent No. 5,840,039, the heart rate probe or sensor (such as the telemetric transmitter unit described previously) may be in electrical communication with either data acquisition
20 component 20 or data display component 7 by means of one or more wires.

Data Display Component

As mentioned above, display component 7 receives an electrical signal from data acquisition component 20 via a wired or wireless link 64 (see Fig. 5). This electrical signal will generally include data indicative of one or more of the
25 following: location, altitude, velocity, pace, distance traveled, heading, blood oxygen level and heart rate. The electrical signal may be received, for example, by receiver 76 (which may alternatively comprise a transceiver). The received electrical signal is then provided to processor 75 where the data may be further processed in accordance with instructions stored in memory 77. The acquired
30 data may be processed in processor 75 in a variety of manners, depending

upon, for example, the type of data which the subject or other individual wishes to monitor. After processing, the data may then be displayed on display screen 52. The subject, or other individual monitoring the subject's performance, may even select the type of data to be displayed by, for example, employing switches 53–56. By way of example, the subject may select one or more predetermined formats for data display utilizing input switches 53–56.

Data display component 7 may also include one or more alarms 79 which provide an audible and/or visible indication to the subject or other individual monitoring the subject's performance. Data display component 7 may be programmed such that an alarm 79 will be activated if a data value departs from a predetermined limit or range. For example, the monitoring system of the present invention may be programmed such that an alarm 79 will be activated if the subject's velocity, pace, distance traveled, blood oxygen level or heart rate is outside a predetermined range. In one embodiment, the subject may program the monitoring system of the present invention, such as by using input switches 53–56, in order to set predetermined levels or ranges for a variety of acquired data. For example, the subject can input an alarm level or range for blood oxygen level, such that an alarm 79 will be activated if the subject's blood oxygen level falls below the predetermined level or outside of the predetermined range. Similar alarm set points can be established by the subject or another individual monitoring the subject's performance for velocity, pace, distance traveled and/or heart rate. In this manner, the subject's performance of the physical activity can be precisely controlled. It should be pointed out that alarms 79 may take a variety of configurations, such as a device capable of generating an audible sound (such as a tone or beep) in response to a signal received from processor 75, or a device capable of generating a visible signal (e.g., a blinking light source) in response to a signal received from processor 75.

As further discussed below, data display component 7 may also include one or more status indicators 57 and 58 (see Fig. 10). Status indicators 57 and

58 may be operatively connected to processor 75 such that one of said status indicators is activated when data acquisition component 20 is not operating properly. For example, the status indicators may merely comprise a portion of display screen 52 which illuminates in order to alert the subject or other individual monitoring the subject's performance that, for example, the GPS device has not acquired the necessary satellite signals, or the physiological monitor is not properly acquiring physiological data from the subject.

Exemplary Embodiment of Exercise Monitoring System

As mentioned previously, Fig. 3 depicts a runner using an exemplary exercise monitoring system according to one embodiment of the present invention. In the monitoring system of Fig. 3, data acquisition component 20 is configured to be worn about the waist of the subject. As more fully described herein, the data acquisition component can comprise any of a variety of structures and configurations, and the structure shown in Fig. 3 is merely exemplary of one embodiment of the present invention. The data display component in Fig. 3 comprises a data display component 7 worn about the wrist of the subject. Once again, as more fully described herein, the data display component can comprise any of a variety of structures and configurations, and that shown in Fig. 3 is merely exemplary of one embodiment.

Data acquisition component 20 acquires data while a subject wearing component 20 performs a physical activity. The acquired data is processed and then displayed by data display component 7. In this manner, data may be acquired while the subject performs the physical activity at any location, thus allowing performance testing and monitoring to be performed anywhere. As shown in the perspective view of Fig. 4, data acquisition component 20 includes a support member 15 which generally comprises an elongate member sized and configured to be worn about the user's waist. Support member 15 may be made

from any of a variety of suitable materials, particularly flexible materials such as polyurethane or other plastics which can be manufactured to be both flexible and soft. Support member 15 may include connector elements at each end thereof in order to facilitate securing support member 15 about the user's waist. These connector elements may comprise any conventional elements used to secure a belt about a person's waist, including conventional belt buckle elements, or hook and loop fastener elements. In the embodiment shown, male and female connector elements 21 and 22, respectively, are provided at opposite ends of support member 15. Connector elements 21 and 22 are made from a resilient plastic, thereby allowing male element 21 to be releasably snapped into female element 22 in order to secure support member 15 about the user's waist. Support member 15 may also be adjustable in length to accommodate different waist sizes, and to allow support member 15 to be adjusted for comfort.

As best seen in the enlarged view of Fig. 6, the various modules described previously are mounted on support member 15 in order to provide the desired data acquisition functions. The modules are preferably provided on support member 15 at a side opposite to connector elements 21 and 22 (as shown in Fig. 4). In this manner, support member 15 may be worn about a subject's waist, with connector elements 21 and 22 located in front, with the modules positioned adjacent the subject's lower back. Not only does this arrangement provide for ease of use (i.e., connecting and disconnecting connector elements 21 and 22), it also provides a more comfortable arrangement due to the increased bulk of the modules. In addition, when a probe or sensor (such as an oximeter probe) is incorporated into support member 15, the probe or sensor may be operatively positioned against the subject's lower back. Of course other arrangements may be provided, particularly whenever it is necessary to orient a probe or sensor at some other location with respect to the subject's body.

GPS module 30, oximetry module 40, antenna 80 and processor/transmitter module 60 may be provided on support member 15. Each may be removably attached to support member 15 such that they may be removed and attached as needed, or even replaced by other modules which provide different functionality (such as a heart rate monitor module). Each module generally includes electronic circuitry suitable for performing the desired data acquisition and/or processing function, as described above (e.g., acquiring data indicative of blood oxygen level of a subject wearing support member 15).

While each module may include the necessary circuitry for independently acquiring, processing and transmitting data, the embodiment of data acquisition component 20 depicted in Fig. 4 includes circuitry which allows data and other electrical signals to be passed from one module to another. In this manner, for example, a single processor/transmitter module 60 may be employed for not only processing data from GPS module 30 and oximeter module 40, but also for transmitting such data to display component 7. In addition, one or more power supplies, such as batteries 125, may provide power to multiple modules provided on support member 15. In order to provide such electrical integration of data acquisition component 20 and the various modules attached thereto, support member 15 may include a plurality of electrical conduits to allow electrical signals to be exchanged between the various modules, as desired. Each of the modules (including antenna 80) is configured such that each may be attached to belt 20 in electrical communication with one or more of the electrical conduits of belt 20.

Electrical conduits may be provided on support member 15 in a variety of manners, such as along inner surface 24 or outer surface 23 of support member 15. Alternatively, a plurality of electrical conduits may be provided within the interior of support member 15. As best seen in the cross-sectional view of Fig. 12, a plurality of electrical conduits 63 extend through the interior of support member 15, and are thus protected and insulated by the material from

which support member 15 is formed. Individual conduits may be provided within support member 15 (as shown in Fig. 12), or a flexible electrical strip such as a membrane circuit may be provided within support member 15. One or more separate conduits for transmitting electrical power may also be provided in support member 15. Thus, as seen in Fig. 12, first and second power cables 61 and 62, respectively, extend through the interior of support member 15. Electrical conduits 63 and power cables 61 and 62 may extend through the interior of support member 15 in any of a variety of patterns; generally as necessary to provide the desired electrical connections between the various modules and power supplies. Of course, it will be understood that conduits for transmitting electrical power from batteries 25 to the various modules may also be provided on a flexible electrical strip along with the electrical conduits described previously.

The various modules and support member 15 are configured such that each module may be attached to support member 15 in electrical communication with one or more of electrical conduits 63, and optionally one or both of power cables 61 and 62. As best seen in the top plan view of Fig. 7, wherein the modules have been removed from support member 15, a plurality of electrical apertures 29 (also commonly referred to as female connectors or female electrical terminals) are provided on support member 15. Electrical apertures 29 may be arranged in any desired pattern, and the rectangular grid shown is merely exemplary of one possible arrangement. The arrangement of electrical apertures 29, however, should correspond with the arrangement of electrical connectors provided on each module (as described below). Each aperture 29 is in electrical communication with one of electrical conduits 63. A pair of power apertures 28 are also provided above and below each grid of electrical apertures 28, and each power apertures is in electrical communication with one of first and second power cables 61 and 62.

Turning to Fig. 8 which depicts GPS module 30, a plurality of electrical connectors 33 (also commonly referred to as male connectors or male electrical terminals) extend away from rear surface 34 of GPS module 30. Electrical connectors 33 may be arranged in the same pattern as electrical apertures 29 on support member 15. Similarly, GPS module 30 includes a pair of power connectors 32 which extend away from rear surface 34 of module 30, above and below the grid of electrical connectors 33. In this manner, GPS module 30 may be attached to support member 15, with each electrical connector 33 engaging an electrical aperture 29 on support member 15 and each power connector 32 engaging a power aperture 28 on support member 15. Thus, the arrangement of electrical connectors 33 and power connectors 32 on GPS module 30 should correspond to an arrangement of electrical apertures 29 and power apertures 28 on support member 15. In the embodiment of Fig. 7, each rectangular grid of electrical apertures 28 and corresponding pair of power apertures 28 (i.e., above and below the rectangular grid) are identical. Thus, GPS module 30 can be attached to support member 15 at a variety of locations. The other modules may have an arrangement of electrical connectors 33 and power connectors 32 which is similar to that for GPS module 30 (as shown in Fig. 8). In this manner, each module can be attached to support member 15 at a variety of locations. Alternatively, each module may have a unique configuration which allows that module to be attached to support member 15 only at one or more selected locations.

In order to further secure GPS module 30 to support member 15, a pair of mounting tabs 31 may also extend away from rear surface 34 of module 30. A pair of corresponding mounting apertures 27 are provided on support member 15. Mounting tabs 31 and mounting apertures 27 are arranged such that GPS module 30 may be attached to support member 15 with each mounting tab 31 engaging a mounting aperture 27 on support member 15. Each mounting tab 31 may be resilient in nature such that the end portion of the mounting tab will engage a mounting aperture, thereby securely attaching GPS module 30 to

support member 15. The other modules may each include similar mounting tabs such each module may be securely attached to support member 15 in the same manner. In fact, each module may have a shape and configuration similar (or even identical to) GPS module 30. Of course a variety of alternate configurations may be employed for each module, particularly if the system is designed such that each module can be attached to support member 15 only at a single, predetermined location. It should be pointed out that processor/transmitter module 60 of the embodiment shown in Fig. 4 is sized somewhat larger than GPS module 30 and oximeter module 40. Thus, module 60 may include four mounting tabs 31 for attachment to support member 15 at region P shown in Fig. 7.

While individual power supplies may be provided in each module, one or more power supplies may be provided on support member 15 in order to provide electrical power to each module. A variety of sources of electrical power may be provided, such as rechargeable or non-rechargeable batteries, one or more solar cells, or a combination of any of the foregoing power sources. In the embodiment shown in Fig. 4, a pair of batteries 125 are provided on support member 15 in electrical communication with first and second power cables 61 and 62. Each battery 125 may be removably or permanently secured to support member 15, and may be located internally or externally of support member 15. Each battery 125 may provide power to selected modules, or both batteries may be configured to provide power to all of the modules. A power switch 26 may also be provided on support member 15. Power switch 26 is operable for turning support member 15 on and off (i.e., allowing power to be supplied to the modules when switch 26 is in its on position).

Fig. 15 depicts an alternative data acquisition component according to an embodiment of the present invention. In the embodiment of Fig. 15, the data acquisition component is configured similar to a bra, and therefore includes a fabric article 114 configured to be worn about a subject's chest. A support

member 115 is incorporated into the fabric article. In fact, support member 115 may be configured identical to support member 15 described above, and includes the various modules and other components described in conjunction with the data acquisition component of Fig. 4. Support member 115 may be secured to fabric article 114 in a variety of manners, such as an adhesive or by sewing support member 115 directly to fabric article 114. An opening may also be provided in fabric article 114 in the region of the oximeter probe in order to allow the probe to be urged against the subject's back, such as below the subject's shoulder blade. Of course it will be recognized that support member 115 may be used without fabric article 114, such that support member 115 is merely secured about the subject's chest similar to the manner in which the telemetric transmitter unit of a conventional heart rate monitor is secured about a user's chest.

As best seen in Fig's 11 and 12, probe 41 is integrally provided on support member 15 such that probe 41 extends partially away from inner surface 24 of support member 15. In this manner, support member 15 will urge probe 41 against the subject's skin in the lower back region in order to acquire blood oxygen data. An electrical connector 45 (such as a cable or wire) electrically connects probe 41 to the oximeter module. Probe 41 includes a first light source 42 configured for emitting red visible light, and a second light source 43 configured for emitting infrared light. First and second light sources 42 and 43 may comprise, for example, LED's. Probe 41 also includes a light sensor 44. Thus, probe 41 may acquire blood oxygen and heart rate data in the manner described previously.

Figure 18 depicts an alternative embodiment of a physiological monitor for use with the data acquisition component of the monitoring system of the present invention. In the embodiment of Fig. 18, probe 141 is remote from the support member for the data acquisition component of the monitoring system. Thus, probe 141 is operatively connected to oximeter module 130 by means of

a cable 145. Of course another suitable wired or wireless link may be used in place of cable 145. The configuration of Fig. 18 is advantageous in that probe 141 may be attached to the subject in a variety of locations, such as the subject's lower back, torso, beneath the shoulder blade, or even on the subject's head (such as on the subject's forehead). Therefore, probe 141 may be positioned in a variety of locations. The embodiment of Fig. 18 is also advantageous when the monitoring system is used on a non-human subject such as a horse. Probe 141 may be attached to the horse's forehead (such as using adhesive or a suitable harness), while a jockey or trainer riding the horse wears data acquisition component 20 (such as around their waist).

Display Component

As discussed previously, particularly in conjunction with the description of the schematic illustration of Fig. 5, the monitoring system of the present invention includes a display component (or display unit) for displaying data which has been acquired and processed by the data acquisition component. The display component of the monitoring system of the present invention may comprise any of a variety of structures suitable for displaying data and other information to the subject or an individual monitoring the subject's physical activity (such as a trainer or a coach). The display component may therefore comprise a personal computer having a monitor associated therewith, wherein the personal computer receives data from the data acquisition component via a wired or wireless connection. Alternatively, the display component may comprise a display device which is configured for use in a particular physical activity, such as a display unit which attaches to a bicycle in a location visible to the rider (e.g. a handlebar-mounted display unit).

The display component may alternatively comprise a "heads-up" type display unit configured for displaying data and other information directly to the subject. As used herein, the term "heads-up display unit" refers to any display

device which is configured to display data to the subject in front of the subject's face. Such a device may be configured to project data and other information onto glasses worn by the subject, swimming goggles, a visor worn by the subject (such as a visor attached to a bicycle helmet), or even onto a display screen which is physically attached to helmet, visor, hat or other structure positioned on the subject's head in a position so that data and other information displayed thereon is directly visible to the subject. Figure 19 depicts an exemplary heads-up display unit 107 comprising glasses of the type described in patent application number WO 99/23524 (which is incorporated herein by way of reference). Such glasses include a display assembly 153 which displays data onto eyeglass lens 152. A cable (or wire) 154 connects the glasses to processor/transmitter module 60, through peripheral interface 68 provided on module 60. Such a display device is available from the MicroOptical Corporation of Boston, Massachusetts. Alternatively, the display device described in patent application number WO 99/23525 (which is incorporated herein by way of reference) may be used. The display device described in this latter patent application essentially provides a display screen positioned in front of the subject's eyeglasses (or is otherwise positioned in front of the subject's face) so that the subject may view data and other information provided on the display screen while still being able to see through the glasses. The focal point of the display screen, however, may be adjusted so as to appear several feet in front of the subject's glasses. In this manner, the subject may view the data and other information provided on the display screen, while still being able to use the glasses in a normal fashion. Other suitable heads-up type display devices are well-known to those skilled in the art, and may be utilized in the monitoring system of the present invention.

Figures 9 and 10 depict yet an exemplary display component 7 according to one embodiment of the present invention. Display component 7 comprises a wrist watch-type display unit which may be worn about the subject's wrist. Display unit 7 includes a flexible band 51 by which the display component may

be secured about a subject's wrist. Display component 7 also includes a display screen 52, which may be configured similar to the display screen of a digital wrist watch. Thus, display screen 52 is configured so as to display data and other information to the subject by means of an LCD screen, or other suitable means well-known to those skilled in the art. Display component 7 further includes actuators or switches 53–56 which allow the subject to operate and control the monitoring system of the present invention. Display screen 52 also may be subdivided into a number of regions which are configured to display specific information to the subject. For example, first display region 70 may be configured as a three digit display which provides the subject's blood oxygen level (as a percentage of saturation) or the subject's heart rate (in beats per minute). Second display region 71 is similarly configured as a three digit display, which may be used to display the subject's velocity (in miles per hour or kilometers per hour) or the subject's pace (e.g., in minutes per mile). A third display region 72 is also shown, and may be configured to display, for example, elapsed time.

Display screen 52 also includes first and second status indicators 57 and 58. Status indicators 57 and 58 may be configured such that status indicator 57 will illuminate when the GPS device has acquired the necessary satellite signals for measurement purposes. Second status indicator 58 may similarly illuminate when the sensor or probe for the physiological monitor (such as an oximeter or heart rate monitor) is operable and acquiring physiological data from the subject. First and second mode indicator 73 and 74 may also be provided on display screen 52. First mode indicator 73 merely indicates to the subject the current mode of operation of display component 7. During use, the subject may alter the mode of operation of display component 7 in order to alter the particular data or other information displayed on display screen 52. The subject may utilize mode switch 54 to toggle display screen 52 so as to display one or more of the following data: blood oxygen level, heart rate, elapsed time ("TM"), average speed, maximum speed, year-to-date miles or kilometers ("YTD"), or the current

time ("clock mode" or "CL"). Second mode indicator 74 merely indicates to the subject whether or not data is being displayed in terms of miles per hour, kilometers per hour, or minutes per mile.

5 In order to operate display component 7, a number of actuators or switches are provided. Thus, as mentioned above, mode switch 54 is used to toggle display screen 52 between various modes of operation. Start/stop switch 53 may be used to commence data measurement. For example, the subject may press start/stop switch 53 when they begin performing a physical activity such that the measurement of elapsed time and distance traveled will begin at that point. When the start/stop switch 53 is depressed a second time, measurement of elapsed time and distance traveled will stop, similar to the manner in which a chronograph is employed. Display component 7 also includes third and fourth actuators 55 and 56 positioned on either side of display screen 52. Actuators 55 and 56 may be used for a variety of purposes, depending upon the configuration of the monitoring system. For example, actuator 55 may be used to toggle first display region 70 between displaying blood oxygen level and heart rate. Similarly, actuator 56 may be used to toggle second display region 71 between displaying miles per hour, kilometers per hour, or minutes per mile.

20 Figures 13 and 14 depict an alternative display unit 107 which is configured to be mounted on a bicycle such that a subject riding the bicycle can view the data displayed on display unit 107. Display unit 107 includes a main housing 151 and a clamp member 160 positioned beneath main housing 151. Main housing 151 and clamp member 160 each include a semi-circular groove such that when main housing 151 and clamp member 160 are positioned as shown in Fig. 14, a circular opening is provided therebetween. This circular opening is sized and configured to accept a handlebar 185 of a bicycle. In this manner, when clamp member 160 is secured to main housing 151 (such as by means of screws 161), handlebar 185 is securely held between clamp member 160 and main housing 151 as shown.

5 Display unit 107 further includes a display screen 152 which may be configured in the same manner as display screen 52 of the display unit shown in Fig. 10. Display unit 107 also includes input switches 153-156, which may be configured in the same manner as input switches 53-56 on the display unit shown in Fig. 10. Thus, display unit 107 is essentially the same as display unit 7 of Fig. 10, except that the clamping mechanism described above has replaced band 51 of the display unit shown in Fig. 7. It should be noted that band 51 of display unit 7 of Fig. 10 may also be used to secure display unit 7 to the handlebars of a bicycle, particular if band 51 employs a hook and loop fastening system.

Analytical and Training Methods

15 While the monitoring system of the present invention may simply display the exercising subject's location (e.g., in terms of longitude and latitude), altitude, velocity, pace, heart rate (e.g., in beats per minute), distance traveled, and/or blood oxygen level (e.g., as a percentage of saturation), the monitoring system of the present invention may be configured to further process, analyze or otherwise utilize this data. In this manner, the monitoring systems of the present invention may be used to monitor, analyze and/or control a subject's performance of a physical activity at any location.

25 By way of example, runners are very interested in monitoring their velocity, pace and/or total distance run. A simple pedometer may provide a rough estimate of the total distance run, however, such devices are inaccurate and do not provide a direct measurement of velocity or pace. While treadmills typically provide an accurate measurement of velocity, pace and total distance, many runners prefer outdoor running. Running on a track or premeasured route will also provide a measure of total distance run, however, many runners do not want to be restricted to running round and round on a track or on the same

course day after day. In addition, the runner will be unable to determine their instantaneous velocity, pace or total distance traveled.

In order to overcome the above problems, the monitoring systems of the present invention which include a GPS device may be configured to provide more than just location information. As described previously, the location data acquired by the GPS device may be used to compute and display the subject's velocity, pace and/or distance traveled. Such information is particularly useful when the subject is performing a physical activity wherein performance may be measured in terms of speed, time and/or distance, such as walking, running, swimming, wheelchairs (e.g., wheel chair racing), bicycling, skating (e.g., speed skating on any surface), skiing (e.g., cross-country skiing), or boating (e.g., rowing, sailing, kayaking, or canoeing), or climbing (e.g., rock climbing). When the system is worn by a human subject performing a physical activity, he or she may simply view the display screen at any time in order to obtain their speed, pace and/or distance traveled. Alternatively, particularly when the subject is an animal such as a horse, the display screen may be viewed by another individual (such as a trainer or even a jockey) in order to monitor the animal's speed, pace and/or distance traveled.

A monitoring system according to one embodiment of the present invention may also be configured (e.g., programmed) to provide a visual and/or audible alarm which is responsive to data provided by the GPS device and/or a physiological monitor (when provided). In one embodiment, the system is user-programmable so that a visible and/or audible alarm is activated when at least one of the subject's speed, pace, blood oxygen level and heart rate departs from a predetermined target, and/or when the subject has traveled a predetermined target distance. For example, a runner may input a predetermined pace of 6:00 per mile (a pace "set point"). Thereafter, the system alarm will activate whenever the runner's pace departs from the desired 6:00 per mile pace by more than a certain amount (e.g., $\pm 10\%$). The alarm will remain activated until

the runner's pace returns to the desired level. The runner may also input a predetermined distance. Thereafter, the system alarm will activate when the runner has traveled this predetermined distance. In this manner, the runner can precisely control their speed and/or total distance without having to run on a treadmill or track.

5

The monitoring system may also be configured such that multiple targets (or set points) may be established by a user (e.g., the subject performing the physical activity, or a coach or trainer). For example, a runner may wish to perform interval training wherein they maintain a first predetermined pace for a first predetermined period of time or distance, and thereafter maintain a second predetermined pace for a second predetermined period of time or distance. Thus, the monitoring system of the present invention may be configured to allow for the input of multiple setpoints (or targets) and multiple time or distance intervals. Thereafter, a system alarm will activate when the runner's pace departs from a specified setpoint of a particular interval, thereby allowing the runner to perform interval training at precise speeds and/or distances.

10

15

The systems of the present invention may also be configured for recording speed, pace and/or distance traveled data, and maintaining such data in memory for later retrieval and/or display. For example, the start button (or other input device) may be activated in order to commence recording of data (such as to coincide with beginning performance of the physical activity). The stop button (or other input device) may thereafter be activated upon completion of the physical activity. Speed, pace, average speed, average pace, elapsed time and/or distance traveled data may then be retrieved from memory and displayed.

20

25

When the system of the present invention includes both a GPS device and a physiological monitor, data provided by the GPS device may be used in conjunction with data provided by the physiological monitor. While heart rate

and blood oxygen data is useful, the utility of such data is greatly improved if the subject's workload is also known. Thus, embodiments of the monitoring system of the present invention which includes both a GPS device and a physiological monitor allow for the monitoring of a physiological parameter (e.g., heart rate or blood oxygen level) and workload. A user may even input their weight so that the monitoring system may compute real-time workload based upon the subject's velocity and altitude changes. In this manner, the system even accounts for elevational changes when determining (and even displaying) the subject's workload. Thus, meaningful data can be obtained even when the subject is exercising at varying altitudes (e.g., running or biking on hilly terrain).

Applicants have also found that monitoring blood oxygen levels while performing a physical activity provides data which is useful for both training and analytical purposes. For example, applicants believe that blood oxygen data provides an indicia of metabolic function, and therefore provides an effective training parameter which can replace or be used in conjunction with heart rate monitoring. As further described below, blood oxygen monitoring also allows for training and analytical techniques which are generally difficult to implement using conventional physiological monitoring such as heart rate monitoring.

As an individual performs a physical activity, the working muscles consume oxygen at a rate which is higher than the rate of oxygen consumption while at rest. The body compensates for the increased oxygen requirements by increasing oxygen intake and/or blood flow. Oxygen intake may be increased, for example, by increasing breathing rate and/or the volume of air inhaled in each breath, while blood flow is increased by an increase in heart rate. At low levels of physical exertion, the blood oxygen level will remain at or near the subject's normal resting level. At these low levels of exertion, energy is primarily provided by an aerobic metabolic process which consumes oxygen. Since the cardiovascular system is able to supply sufficient oxygen to meet the body's demands, blood oxygen level remains at or near the normal resting levels.

As the level of exertion is increased, however, the cardiovascular system is unable to supply sufficient oxygen to meet the demands of working muscles. Thus, the body will begin to supply a portion of the energy requirements by an anaerobic metabolic process which does not consume oxygen. However, lactic acid is a byproduct of the anaerobic process, and must be eliminated by the body in order to prevent muscle failure. When only a small portion of the subject's energy requirements are provided by the anaerobic process, the body is generally able to eliminate the lactic acid byproduct. As the level of exertion is increased, however, the anaerobic process is responsible for more and more of the body's energy requirements. Eventually, the body is unable to eliminate lactic acid at the same rate that it is being produced. At this point (often referred to as the "lactate threshold" or "LT"), lactic acid will begin to accumulate in the working muscles, eventually leading to muscle failure. If the subject continues to perform at a level of exertion above LT, it is only a matter of time until the working muscles begin to fail and the subject must stop.

Applicants have surprisingly found that blood oxygen data provides an indirect measurement of the body's metabolic functioning. For example, as the level of exertion is progressively increased, the blood oxygen level will decrease. The plot shown in Fig. 16 depicts a runner's heart rate and blood oxygen level as their workload is progressively increased. Workload can easily be computed on the basis of the subject's weight and speed (and optionally altitude changes if running on a hilly course), and the monitoring system of the present invention can readily compute and display the subject's workload. As noted from the plot Fig. 16, heart rate increases with workload, while blood oxygen level decreases. Thus, it is apparent that blood oxygen level (particularly systemic blood oxygen level) varies with the metabolic functioning of the body. In fact, Applicants' discovery that blood oxygen level provides an indicator of metabolic function is quite useful in that blood oxygen data can now be used to monitor, analyze and/or control a subject's performance of a physical activity. Thus, the present invention provides methods using blood oxygen data

to perform one or more of these functions. In fact, embodiments of the monitoring system of the present invention may be configured (e.g., programmed) to provide one or more of these functions (such as activating an alarm when the subject's blood oxygen level departs from a predetermined target level or range). It should be pointed out, however, that the methods of the present invention which utilize blood oxygen data need not be performed using the exercise monitoring systems of the present invention.

One particular method provided by the present invention is a method of controlling (i.e., regulating) a subject's physical activity by monitoring the subject's blood oxygen level, and maintaining the subject's blood oxygen level at a selected level (such as a setpoint or a range) while the subject continues to perform the physical activity. Such a method can provide an effective training tool for athletes in that they (or their coaches) can more effectively control training sessions, or even monitor their performance during a race. For example, if a marathoner knows their appropriate blood oxygen level for completing a marathon, they can monitor their blood oxygen level during the race in order to ensure that their blood oxygen level does not exceed or fall below their target level.

The subject's blood oxygen level can be maintained at a selected level by adjusting the subject's workload (e.g., slowing down, speeding up, changing gears on a bike, etc.). Similarly, the subject's level of exertion may also be modified as needed in order to maintain their blood oxygen level at the selected level. The subject's oxygen intake may even be modified in order to maintain blood oxygen at the selected level. For example, various devices are available for regulating the amount of oxygen which is inhaled by an exercising subject (such as by restricting air flow to the user's lungs). A swimmer can also regulate their oxygen intake by regulating their breathing. Thus, a swimmer can even use the monitoring systems of the present invention (particularly an embodiment having an audible alarm which activates when blood oxygen departs from the

selected level) to regulate their blood oxygen by altering breathing patterns. A subject can also control the depth or volume of their breathing (e.g., deep or shallow breathing) in order to maintain blood oxygen at the desired level. The subject's blood oxygen level can also be maintained at a plurality of selected levels for one or more predetermined intervals. Thus, interval training can be performed based upon blood oxygen data.

The subject may also perform initial testing in order to determine desirable blood oxygen levels or heart rate for subsequent training or competition. For example, the subject may perform a test routine which estimates the subject's lactate threshold (i.e., the subject's blood oxygen level or heart rate at their lactate threshold). Thereafter, the subject may perform a physical activity at a blood oxygen level which is selected on the basis of their previously determined lactate threshold ("LT"). By way of example, the subject's LT may be determined using a plot similar to that of Fig. 16. The subject performs a physical activity while their blood oxygen level is monitored. The subject's workload (e.g., speed) is then incrementally increased at predetermined intervals (e.g., increase speed by 1% every two minutes) until exhaustion (or some other selected endpoint). When blood oxygen is plotted against workload (or even speed), the subject's LT will generally correspond to the point of inflection identified at A in Fig. 16.

As yet another alternative, a fitness parameter (such as LT) of a subject may first be determined. Thereafter, the same fitness parameter may be measured on subsequent occasions in order to measure improvements in the subject's fitness.

The monitoring system of the present invention described above may even be programmed to provide for determining a fitness indicator (such as LT). The subject's weight may be inputted into the system, and the subject will then begin performing the physical activity (e.g., running). The system may

determine the subject's speed and altitude changes, which the system then uses to calculate the subject's workload. The system may even be programmed to signal to the subject when the workload should be increased (such as by activating an alarm). Once the test protocol has been completed, the system will calculate the subject's LT (or other fitness indicator) on the basis of the acquired workload and blood oxygen data. Alternatively, the system may use heart rate (rather than blood oxygen data) to compute the fitness indicator (such as LT) by well-known methods. One such well-known test protocol is the Conconi Test which employs heart rate measurements with increasing workload to determine a subject's VO₂max.

Blood oxygen data can also be monitored while a subject performs a physical activity in order to reduce variability in blood oxygen levels. By stabilizing blood oxygen levels while performing at a constant workload, the subject's performance will be improved. Thus, the monitoring system of the present invention may be configured to measure the time variability of the subject's blood oxygen level, particularly when the workload remains at a substantially constant level. The time variability may simply be calculated as the standard deviation of blood oxygen over a predetermined time interval (e.g., the standard deviation of blood oxygen level over the preceding 5 seconds). The manner in which the physical activity is performed may then be adjusted in order to reduce the time variability of blood oxygen level. In fact, the system may even be configured to activate an alarm if the time variability of the subject's blood oxygen level exceeds a predetermined limit. By way of example, the subject may reduce the time variability of blood oxygen by stabilizing their breathing (e.g., concentrating on deep, rhythmic breathing), or by merely concentrating on stabilizing their workload or level of exertion.

By way of example, the plot of Fig. 17a depicts a runner's blood oxygen level as their pace (in miles per hour) is gradually increased. It will be noted that the subject's blood oxygen level shows significant variability which does not

correlate with increases in workload. In other words, the subject's blood oxygen level shows significant peaks and valleys, rather than gradually decreasing as would be expected. When blood oxygen level drops and rises rapidly, the subject's performance will suffer. For example, lactate levels may begin to rise, leading to premature muscle failure. Figure 17b is a plot from the same runner, however the runner concentrated on their breathing (i.e., rhythmic, deep breathing from their belly, rather than from their chest). The result is that blood oxygen levels are more stable, even though the workload is increasing. In fact, the subject's blood oxygen level in Fig. 17b remained substantially constant at about 96% when pace was increased from about 6mph to about 9mph. In the plot of Fig. 17a, however, the subject's blood oxygen level varied between about 91% and about 98% over this same pace range. Such variability in blood oxygen level will inevitably lead to decreased performance.

1. An exercise monitoring system, comprising:
 - (a) an electronic positioning device;
 - (b) a physiological monitor; and
 - (c) a display unit configured for displaying data provided by said electronic positioning device and said physiological monitor.
2. The exercise monitoring system of claim 1, wherein said electronic positioning device is configured to receive electromagnetic signals from three or more sources so that said monitoring system can determine at least one of a subject's location, altitude, velocity, pace, and distance traveled.
3. The system of claim 2, wherein said electronic positioning device comprises a GPS device.
4. The system of claim 1, wherein said physiological monitor is chosen from the group consisting of: an oximeter and a heart rate monitor.
5. The system of claim 4, wherein said electronic positioning device comprises a GPS device.
6. The system of claim 3, wherein said GPS device and said physiological monitor are provided as part of a user-wearable data acquisition unit which is separate from said display unit.
7. The system of claim 6, wherein said data acquisition unit further comprises a support member, and said GPS device and said physiological monitor are provided on said support member.
8. The system of claim 7, wherein said GPS device and said physiological monitor are removably secured to said support member.

9. The system of claim 6, wherein said data acquisition unit is configured to be worn about a human user's waist.
10. The system of claim 6, wherein said data acquisition unit is configured to be worn about a human user's chest.
11. The system of claim 1, wherein said display unit is configured to be worn about a human user's wrist.
12. The system of claim 1, wherein said display unit is configured to be mounted to a bicycle.
13. The system of claim 1, wherein said display unit is configured to be worn about a human user's wrist.
14. The system of claim 1, wherein said physiological monitor includes a probe configured for acquiring physiological data from a user.
15. The system of claim 4, wherein said physiological monitor comprises an oximeter.
16. The system of claim 4, wherein said physiological monitor comprises a heart rate monitor.
17. The system of claim 1, wherein said system further comprises an alarm which is activated when data provided by at least one of said electronic positioning device and said physiological monitor does not meet a predetermined target.
18. An exercise monitoring system, comprising:

- (a) an electronic positioning device configured to receive electromagnetic signals from three or more sources so that said monitoring system can determine a subject's velocity or pace;
- (b) a display unit configured for displaying data provided by said electronic positioning device; and
- (c) an alarm, wherein said alarm is activated when a subject's velocity or pace does not meet a predetermined target.

19. An exercise monitoring system, comprising:

- (a) an oximeter configured to determine a subject's blood oxygen level;
- (b) a display unit configured for displaying the subject's blood oxygen level; and
- (c) an alarm, wherein said alarm is activated when the subject's blood oxygen level does not meet a predetermined target.

20. A method of controlling a subjects physical activity, comprising:

- (a) monitoring a subject's blood oxygen level while the subject performs a physical activity; and
- (b) maintaining said blood oxygen level at a selected level while the subject continues to perform said physical activity.

21. The method of claim 20, wherein said blood oxygen level is maintained at said selected level by adjusting the workload of said physical activity as necessary.

22. The method of claim 20, wherein said blood oxygen level is maintained at said selected level by adjusting the subject's level of exertion as necessary.

23. The method of claim 20, wherein said blood oxygen level is maintained at said selected level by adjusting the subject's oxygen intake as necessary.
24. The method of claim 20, wherein said physical activity is chosen from the group consisting of: walking, running, swimming, bicycling, skating, singing, skiing, boating, climbing, wheelchairs, snowshoeing, scuba diving, and flying.
25. The method of claim 20, wherein said step of monitoring blood oxygen level comprises:
 - (a) providing an oximeter, said oximeter including a probe for non-invasively determining blood oxygen level; and
 - (b) positioning said probe on said subject at a location suitable for detecting the subject's blood oxygen level.
26. The method of claim 25, wherein said probe is positioned such that said oximeter determines the subject's systemic blood oxygen level.
27. The method of claim 25, wherein said location is chosen from the group consisting of the subject's back, head, arm, leg, chest and torso.
28. The method of claim 26, wherein said location comprises the subject's lower back.
29. The method of claim 25, wherein said probe is provided on a support member worn about the subject's waist.
30. The method of claim 20, wherein said subject is chosen from the group consisting of: humans, horses, dogs, camels, and other mammals.

31. The method of claim 20, wherein said selected level comprises a range.
32. The method of claim 20, further comprising the step of maintaining said blood oxygen level at a second selected level.
33. The method of claim 20, further comprising the steps of sequentially maintaining said blood oxygen level at multiple selected levels.
34. The method of claim 33, wherein said blood oxygen level is maintained at each selected level:
 - (a) for a predetermined period of time;
 - (b) until the subject has advanced a predetermined distance; or
 - (d) until the subject has performed a predetermined amount of work.
35. The method of claim 20, wherein said selected level is chosen on the basis of blood oxygen data previously obtained while said subject performed a physical activity.
36. The method of claim 20, wherein said selected level is chosen on the basis of said subject's lactate threshold.
37. The method of claim 20, wherein said selected level is chosen on the basis of the duration of said physical activity.
38. The method of claim 20, further comprising the step of providing an alarm, said alarm configured for indicating when the subject's blood oxygen level is not at said selected level.
39. The method of claim 20, further comprising the step of providing a display unit configured for displaying the subject's blood oxygen level.

40. The method of claim 39, wherein said subject comprises a human, and said display unit is positioned so that the blood oxygen level displayed by said display unit can be viewed by said subject.
41. The method of claim 39, wherein said display unit is positioned so that the blood oxygen level displayed by said display unit can be viewed by someone other than said subject.
42. The method of claim 40, wherein said display unit is worn on the subject's wrist.
43. The method of claim 40, wherein said physical activity comprises bicycling, and said display unit is attached to the subject's bicycle so as to be visible to the subject.
44. The method of claim 40, wherein said physical activity comprises walking or running on a treadmill, and said display unit is provided on said treadmill.
45. The method of claim 20, further comprising the step of measuring at least one of the subject's velocity, pace, or distance traveled.
46. The method of claim 45, wherein said measuring step comprises: providing a GPS device operable for measuring at least one of the subject's velocity, pace or distance traveled.
47. The method of claim 45, further comprising the step of providing a display unit configured for displaying the subject's blood oxygen level, and at least one of the subject's velocity, pace or distance traveled.

48. A method of reducing a subject's blood oxygen level variability while the subject performs a physical activity, comprising:
- (a) periodically measuring a subject's blood oxygen level while said subject performs a physical activity; and
 - (b) adjusting the manner in which said physical activity is performed in order to reduce blood oxygen level variability.
49. A method of performing a physical activity, comprising:
- (a) monitoring a subject's blood oxygen level while said subject performs a physical activity; and
 - (b) indicating to said subject the time variability of the subject's blood oxygen level.
50. The method of claim 49, wherein said time variability comprises the standard deviation of the subject's blood oxygen level.
52. A method of determining a fitness indicator of a subject, comprising:
- (a) recording a subject's blood oxygen level while the subject performs a physical activity;
 - (b) varying the subject's workload while continuing to record the subject's blood oxygen level; and
 - (c) determining a fitness indicator of said subject on the basis of the recorded blood oxygen data.
53. The method of claim 52, wherein said fitness indicator comprises the subject's lactate threshold.
54. The method of claim 53, wherein said step of varying the subject's workload comprises periodically increasing the subject's workload.

55. The method of claim 52, further comprising the steps of providing a GPS device operable for measuring the subject's velocity, and determining the subject's workload using velocity measurements provided by said GPS device.
56. The method of claim 55, wherein said GPS device is further operable for measuring the subject's altitude, and wherein the subject's workload is determined using velocity and altitude measurements provided by said GPS device.
57. A method of stabilizing blood oxygen levels while exercising, comprising:
- (a) monitoring the level of blood oxygen while exercising;
 - (b) adjusting breathing while continuing to exercise in order to stabilize the level of blood oxygen.
58. A method of comparing an individual's physical fitness to their physical fitness on a previous occasion, comprising:
- (a) measuring an individual's blood oxygen level while the individual performs a physical activity at a predetermined workload; and
 - (b) measuring said individual's blood oxygen level on a subsequent occasion while the individual performs said physical activity.

ABSTRACT OF THE DISCLOSURE

An exercise monitoring system which includes an electronic positioning device; a physiological monitor; and a display unit configured for displaying data provided by said electronic positioning device and said physiological monitor.

0485956.05

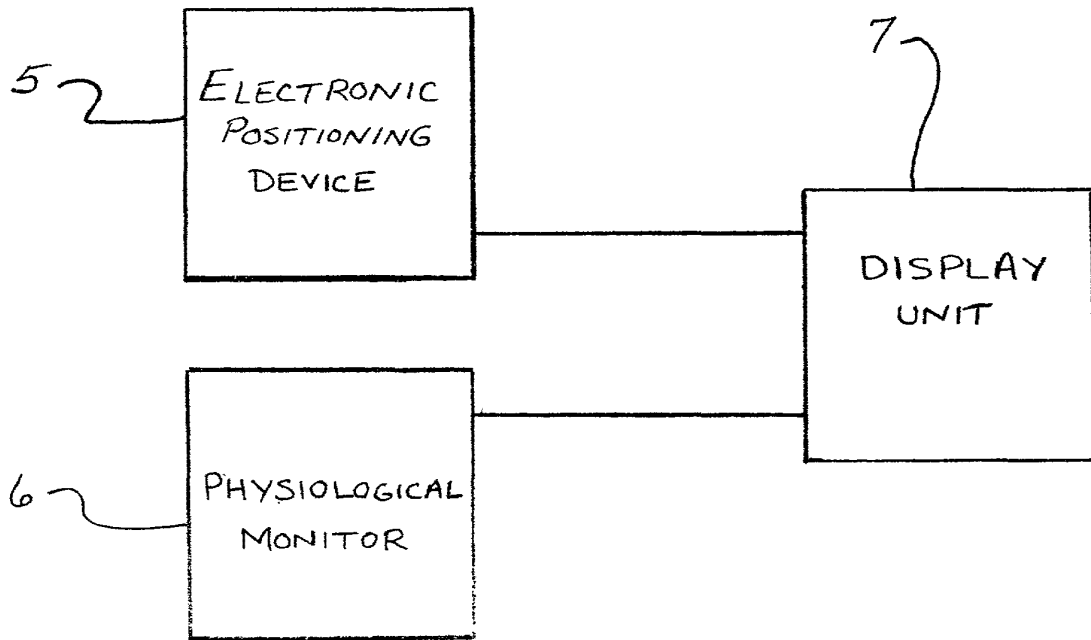

FIG. 1

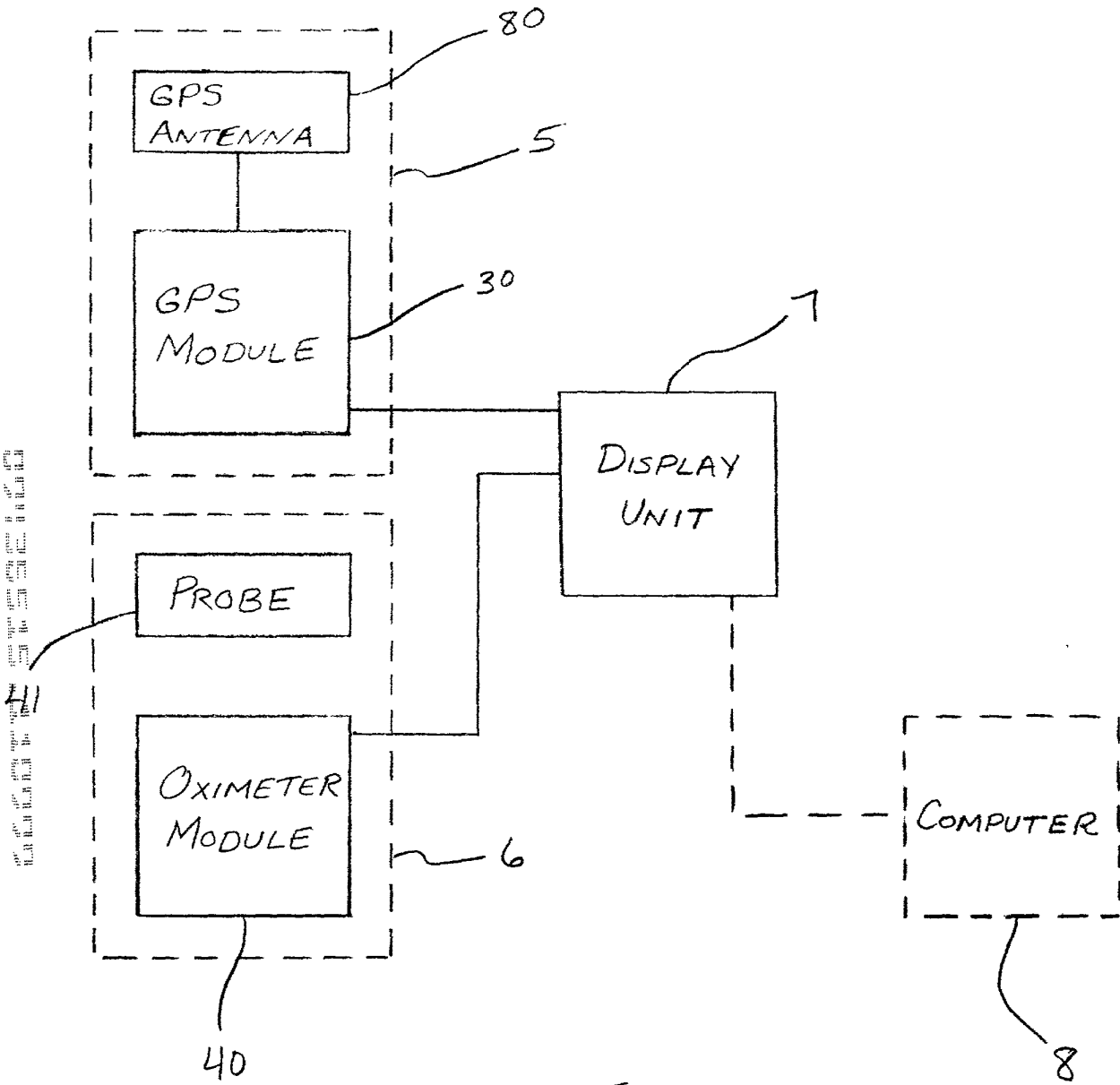

FIG. 2

001 002 003 004 005 006 007 008 009 010 011 012 013 014 015 016 017 018 019 020 021 022 023 024 025 026 027 028 029 030 031 032 033 034 035 036 037 038 039 040 041 042 043 044 045 046 047 048 049 050 051 052 053 054 055 056 057 058 059 060 061 062 063 064 065 066 067 068 069 070 071 072 073 074 075 076 077 078 079 080 081 082 083 084 085 086 087 088 089 090 091 092 093 094 095 096 097 098 099 100 101 102 103 104 105 106 107 108 109 110 111 112 113 114 115 116 117 118 119 120 121 122 123 124 125 126 127 128 129 130 131 132 133 134 135 136 137 138 139 140 141 142 143 144 145 146 147 148 149 150 151 152 153 154 155 156 157 158 159 160 161 162 163 164 165 166 167 168 169 170 171 172 173 174 175 176 177 178 179 180 181 182 183 184 185 186 187 188 189 190 191 192 193 194 195 196 197 198 199 200 201 202 203 204 205 206 207 208 209 210 211 212 213 214 215 216 217 218 219 220 221 222 223 224 225 226 227 228 229 230 231 232 233 234 235 236 237 238 239 240 241 242 243 244 245 246 247 248 249 250 251 252 253 254 255 256 257 258 259 260 261 262 263 264 265 266 267 268 269 270 271 272 273 274 275 276 277 278 279 280 281 282 283 284 285 286 287 288 289 290 291 292 293 294 295 296 297 298 299 300 301 302 303 304 305 306 307 308 309 310 311 312 313 314 315 316 317 318 319 320 321 322 323 324 325 326 327 328 329 330 331 332 333 334 335 336 337 338 339 340 341 342 343 344 345 346 347 348 349 350 351 352 353 354 355 356 357 358 359 360 361 362 363 364 365 366 367 368 369 370 371 372 373 374 375 376 377 378 379 380 381 382 383 384 385 386 387 388 389 390 391 392 393 394 395 396 397 398 399 400 401 402 403 404 405 406 407 408 409 410 411 412 413 414 415 416 417 418 419 420 421 422 423 424 425 426 427 428 429 430 431 432 433 434 435 436 437 438 439 440 441 442 443 444 445 446 447 448 449 450 451 452 453 454 455 456 457 458 459 460 461 462 463 464 465 466 467 468 469 470 471 472 473 474 475 476 477 478 479 480 481 482 483 484 485 486 487 488 489 490 491 492 493 494 495 496 497 498 499 500 501 502 503 504 505 506 507 508 509 510 511 512 513 514 515 516 517 518 519 520 521 522 523 524 525 526 527 528 529 530 531 532 533 534 535 536 537 538 539 540 541 542 543 544 545 546 547 548 549 550 551 552 553 554 555 556 557 558 559 560 561 562 563 564 565 566 567 568 569 570 571 572 573 574 575 576 577 578 579 580 581 582 583 584 585 586 587 588 589 590 591 592 593 594 595 596 597 598 599 600 601 602 603 604 605 606 607 608 609 610 611 612 613 614 615 616 617 618 619 620 621 622 623 624 625 626 627 628 629 630 631 632 633 634 635 636 637 638 639 640 641 642 643 644 645 646 647 648 649 650 651 652 653 654 655 656 657 658 659 660 661 662 663 664 665 666 667 668 669 670 671 672 673 674 675 676 677 678 679 680 681 682 683 684 685 686 687 688 689 690 691 692 693 694 695 696 697 698 699 700 701 702 703 704 705 706 707 708 709 710 711 712 713 714 715 716 717 718 719 720 721 722 723 724 725 726 727 728 729 730 731 732 733 734 735 736 737 738 739 740 741 742 743 744 745 746 747 748 749 750 751 752 753 754 755 756 757 758 759 760 761 762 763 764 765 766 767 768 769 770 771 772 773 774 775 776 777 778 779 780 781 782 783 784 785 786 787 788 789 790 791 792 793 794 795 796 797 798 799 800 801 802 803 804 805 806 807 808 809 810 811 812 813 814 815 816 817 818 819 820 821 822 823 824 825 826 827 828 829 830 831 832 833 834 835 836 837 838 839 840 841 842 843 844 845 846 847 848 849 850 851 852 853 854 855 856 857 858 859 860 861 862 863 864 865 866 867 868 869 870 871 872 873 874 875 876 877 878 879 880 881 882 883 884 885 886 887 888 889 890 891 892 893 894 895 896 897 898 899 900 901 902 903 904 905 906 907 908 909 910 911 912 913 914 915 916 917 918 919 920 921 922 923 924 925 926 927 928 929 930 931 932 933 934 935 936 937 938 939 940 941 942 943 944 945 946 947 948 949 950 951 952 953 954 955 956 957 958 959 960 961 962 963 964 965 966 967 968 969 970 971 972 973 974 975 976 977 978 979 980 981 982 983 984 985 986 987 988 989 990 991 992 993 994 995 996 997 998 999 1000

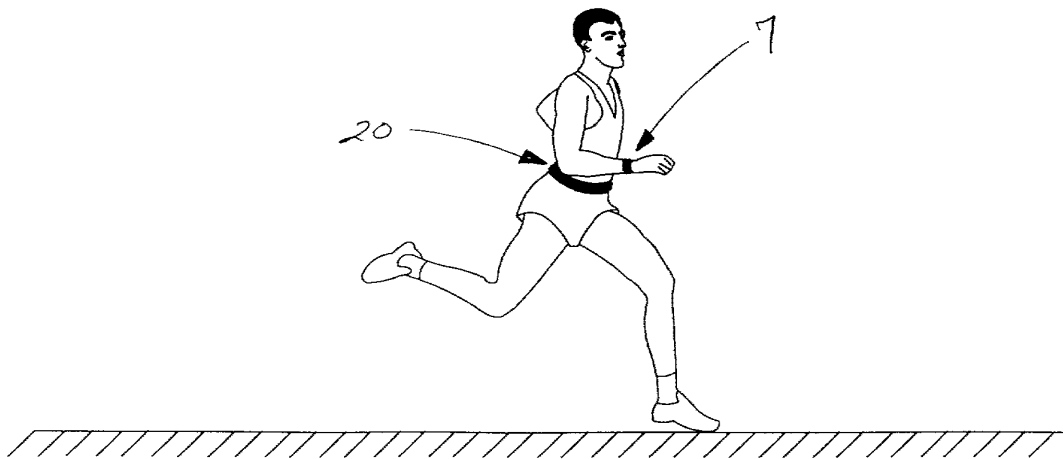
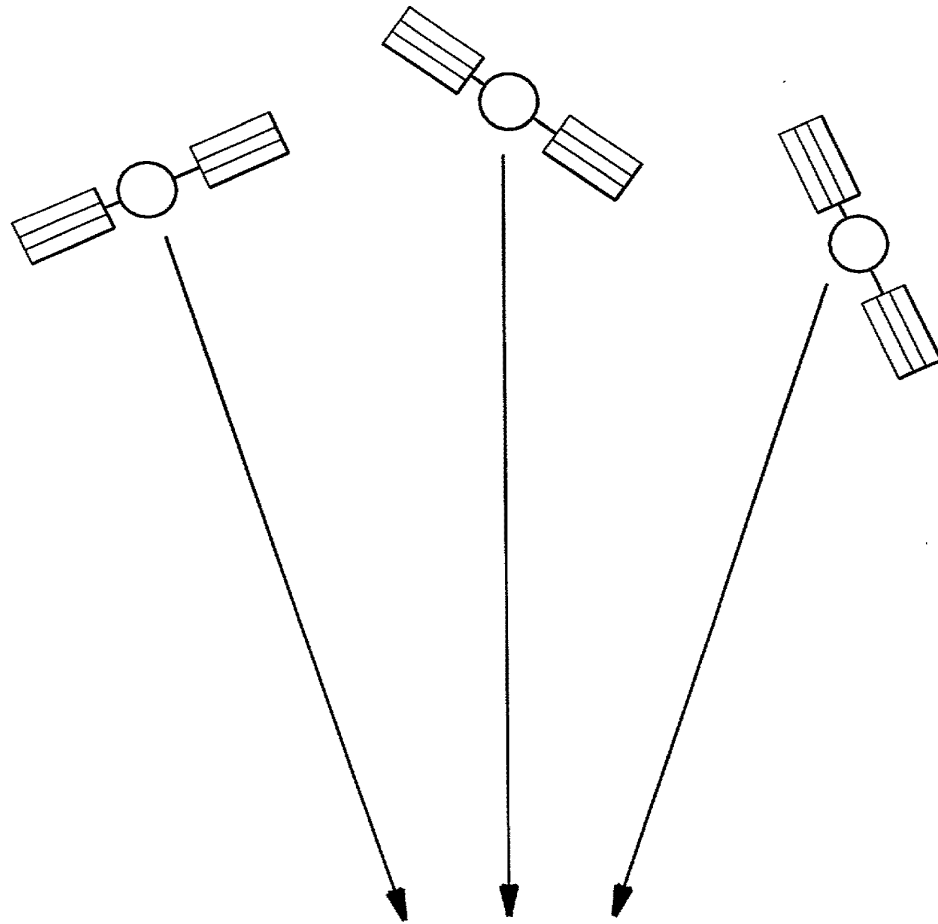
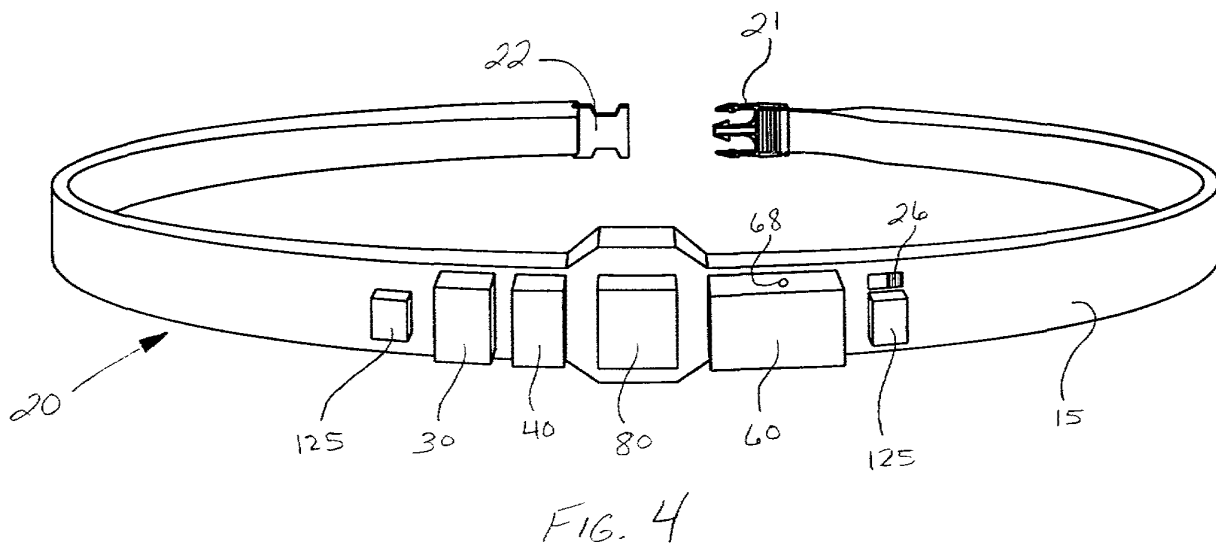
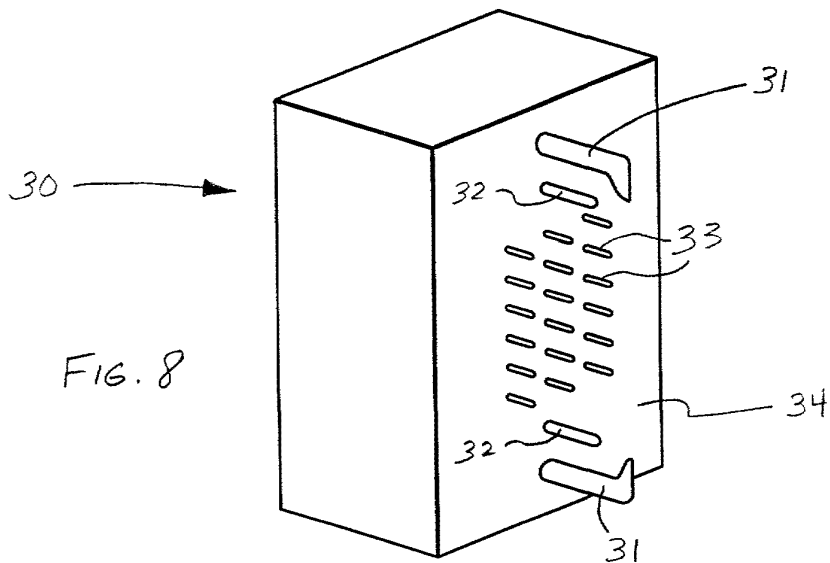
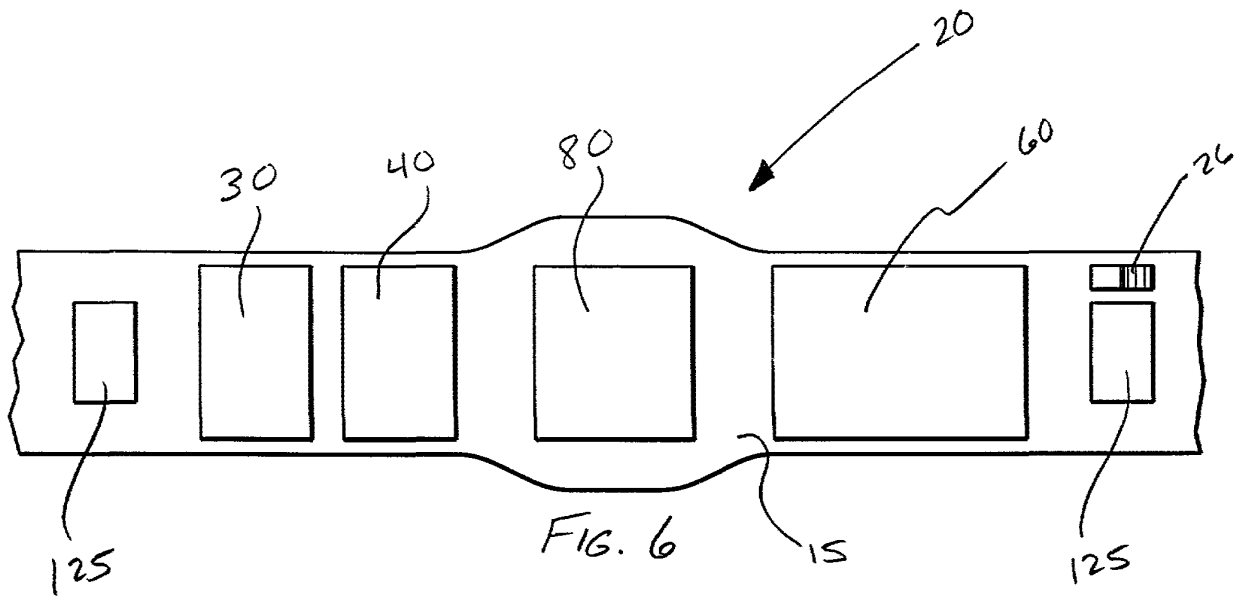

FIG. 3



125 30 40 80 60 26 15 20 31 32 33 34 22 21 68 26 15 20

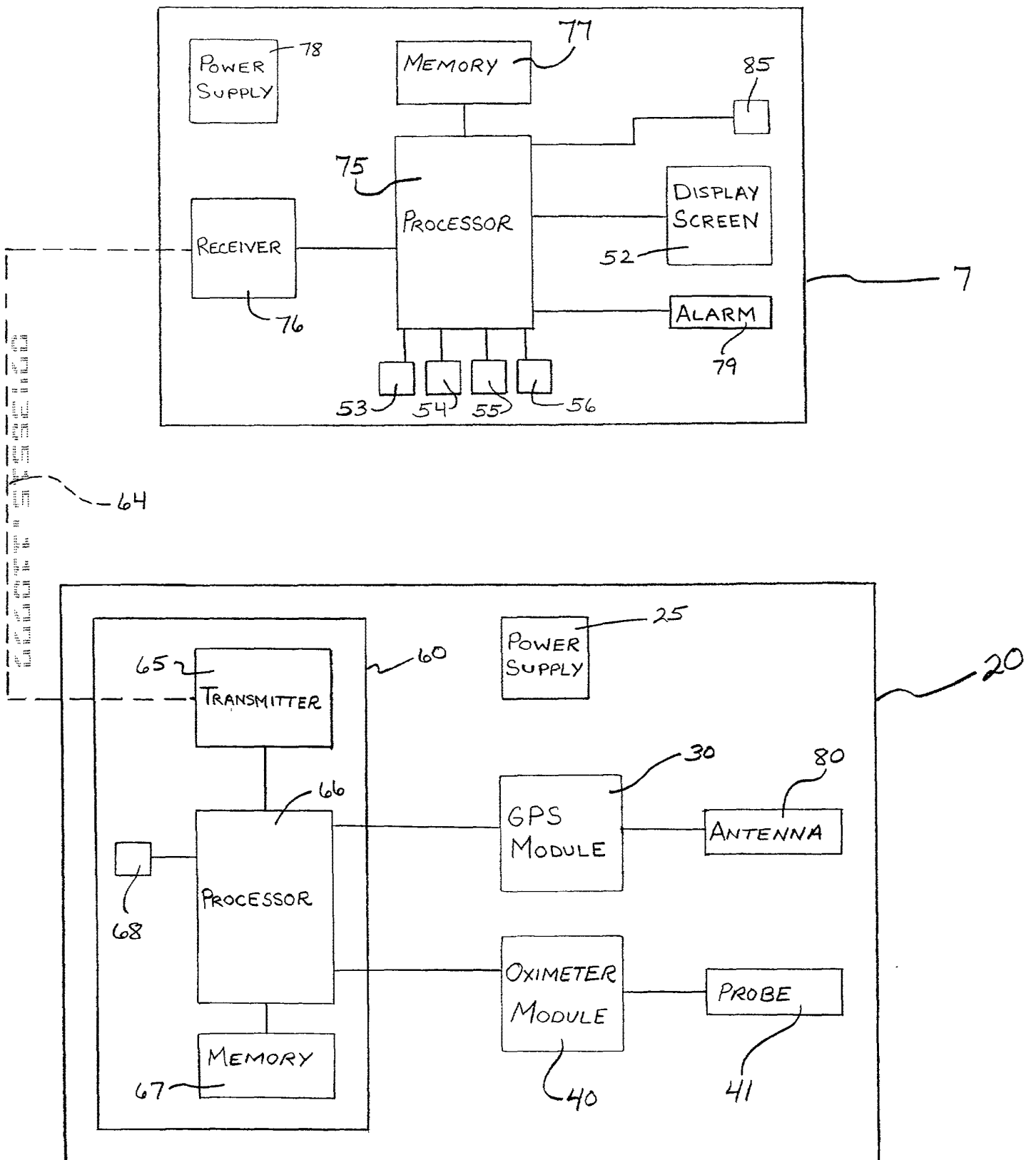

FIG. 5

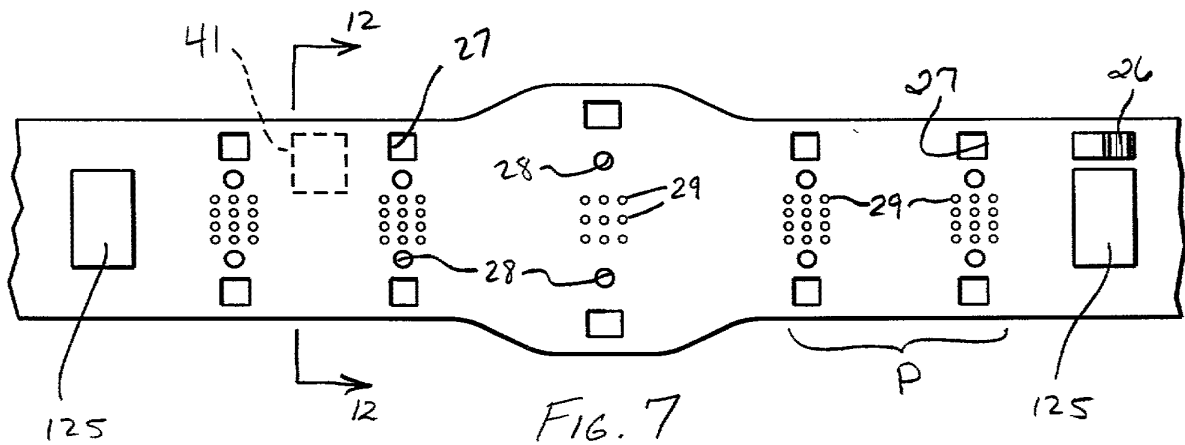

FIG. 7

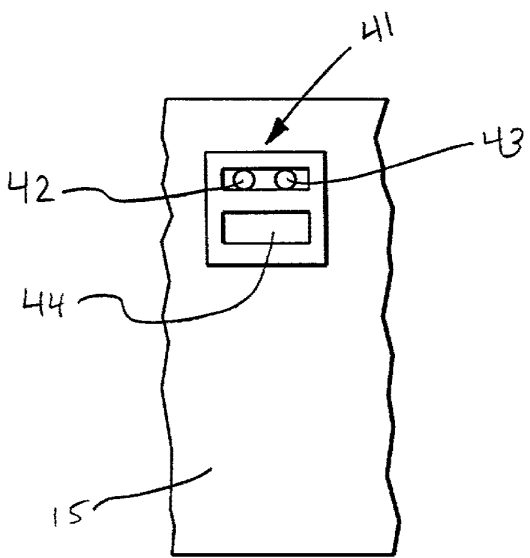

FIG. 11

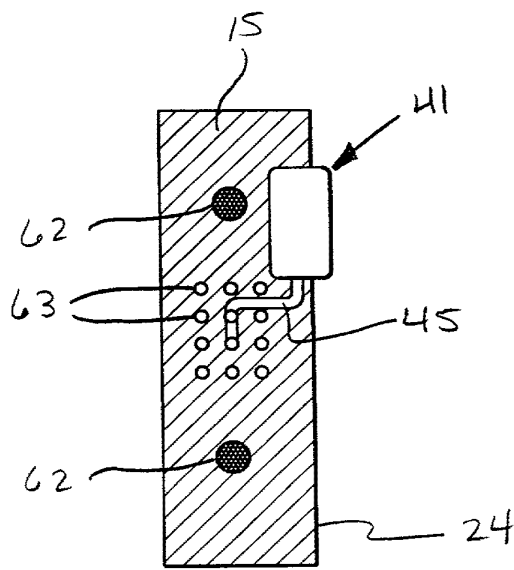

FIG. 12

11/2018 Apple Inc. Patent Application No. 15/800,000, filed Nov. 12, 2018, titled "Flexible Display Device"

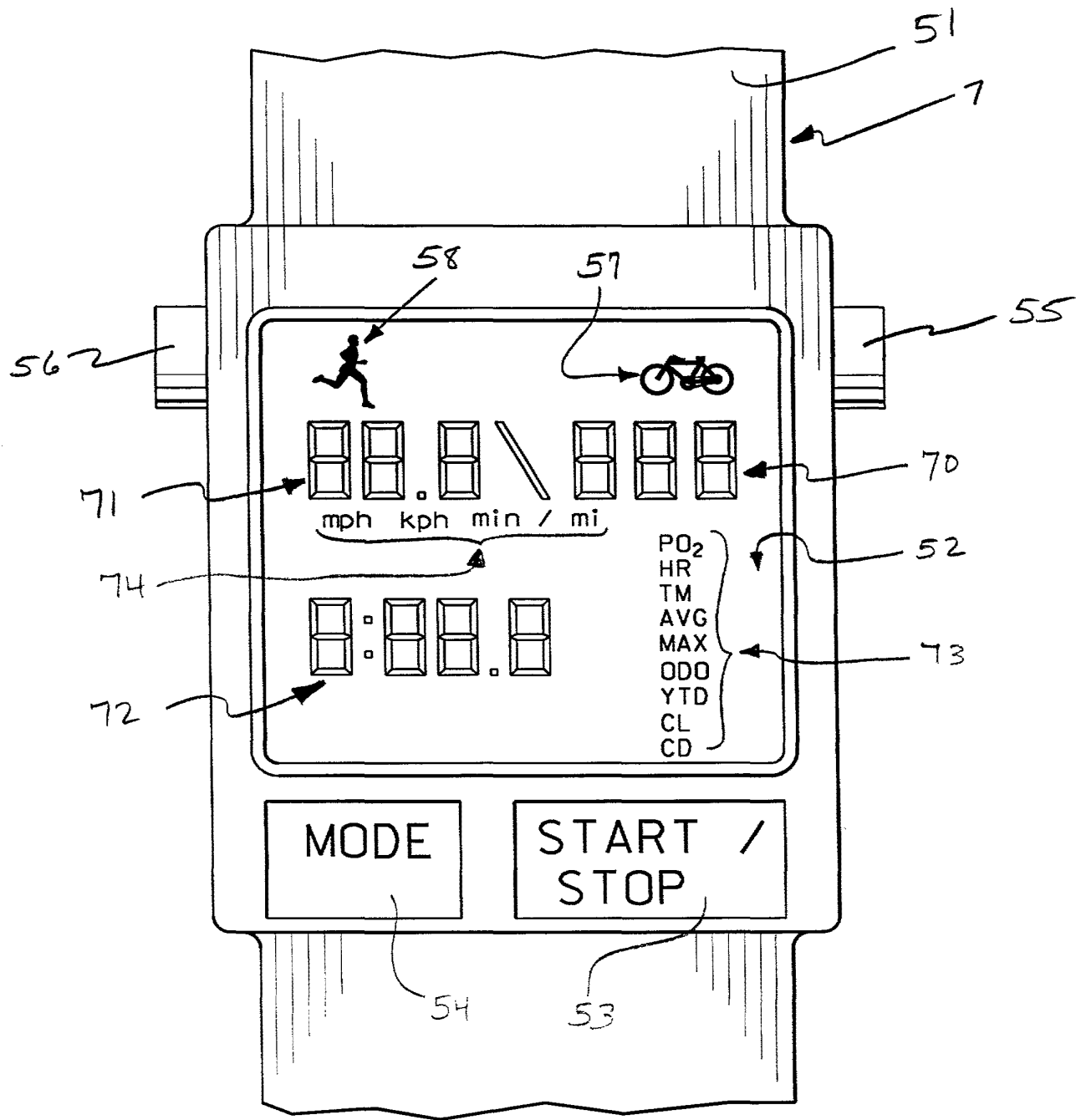

FIG. 10

114
115

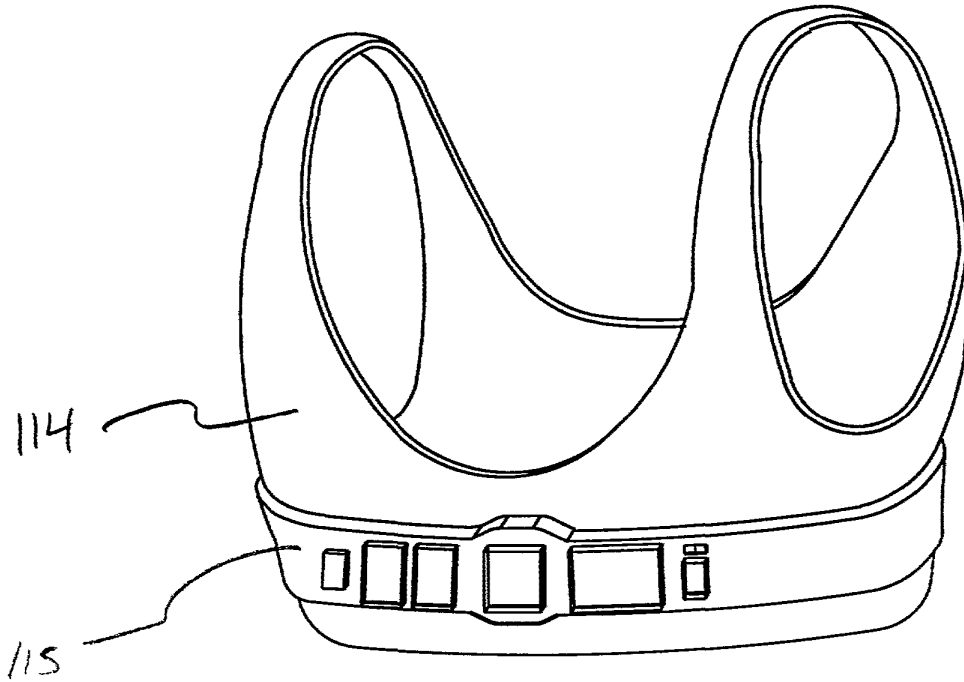

FIG. 15

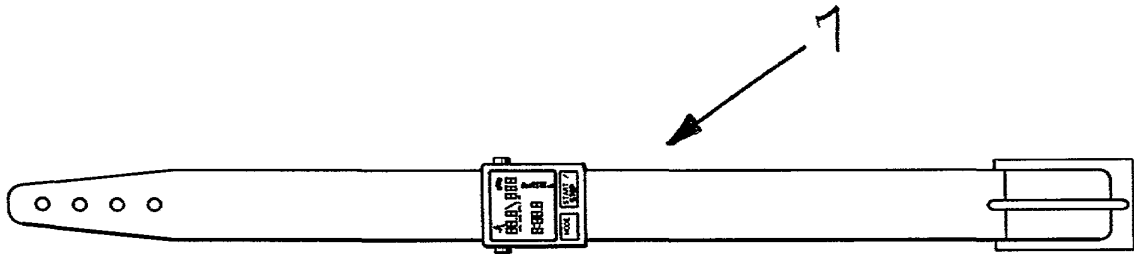

FIG. 9

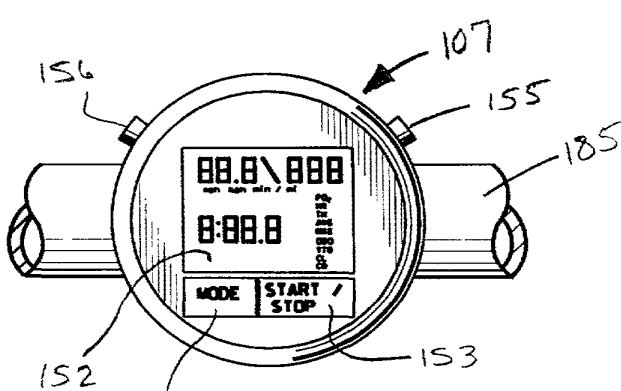

FIG. 13

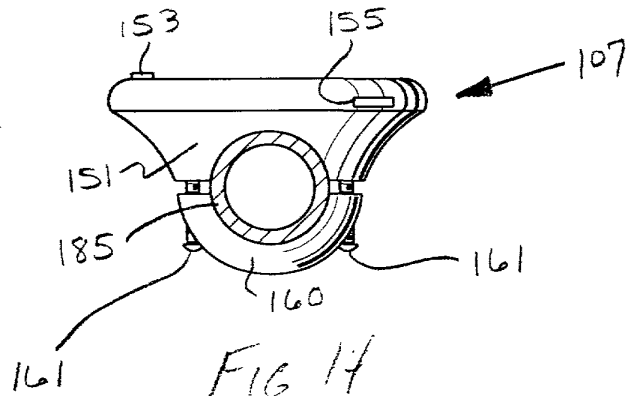

FIG. 14

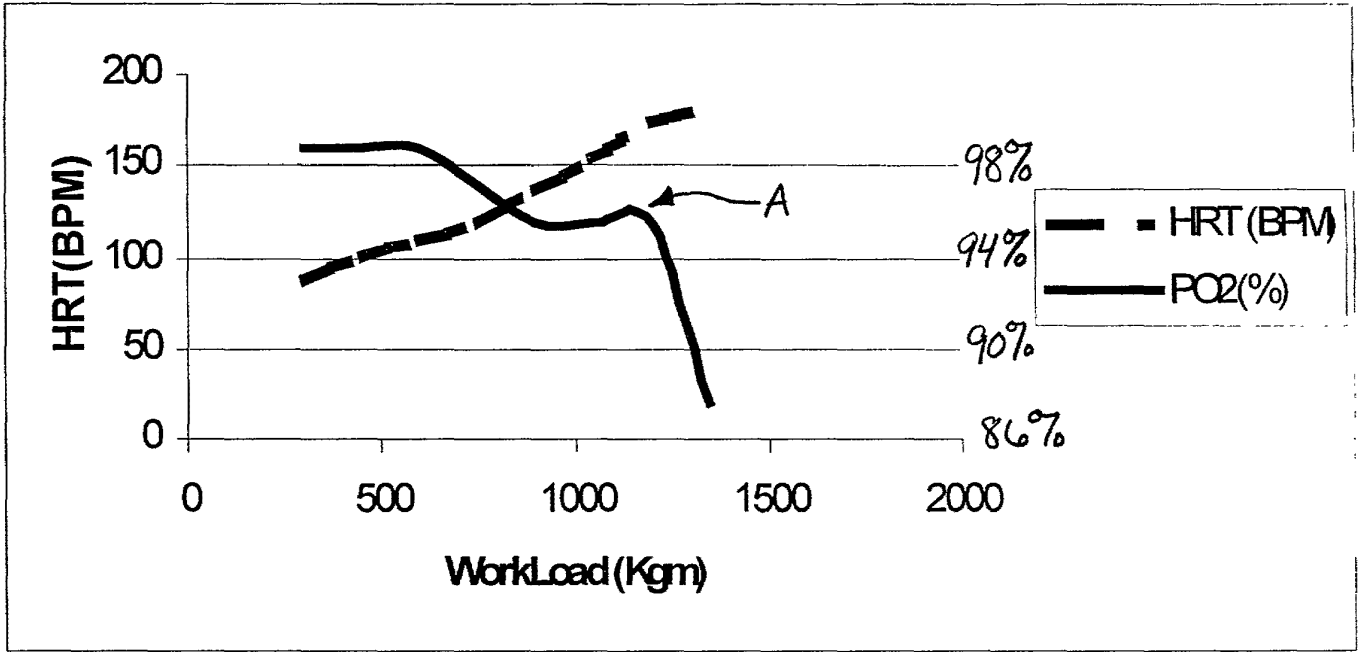

FIG. 16

U.S. PATENT AND TRADEMARK OFFICE

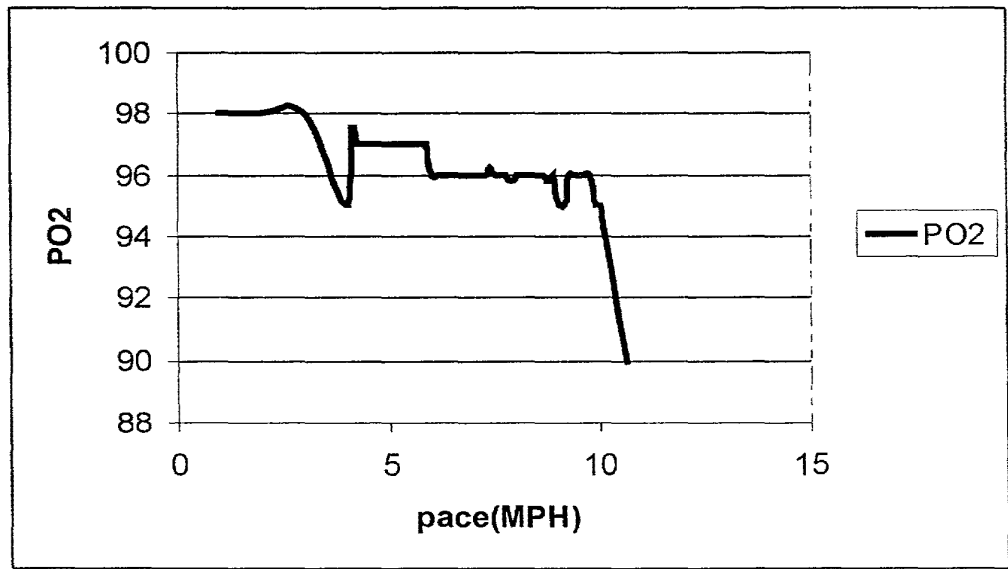
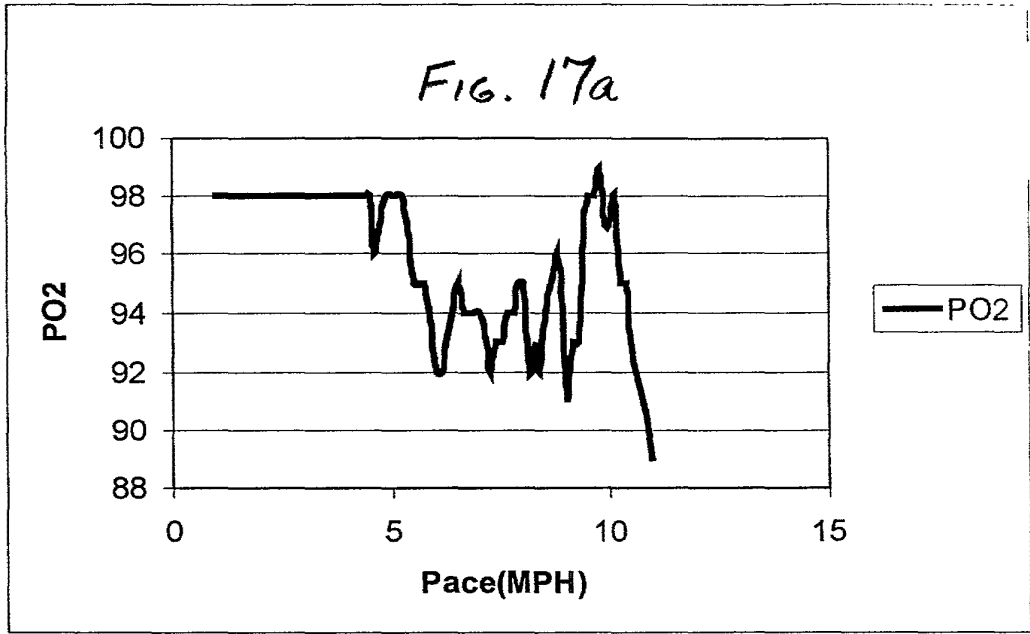

FIG. 17b

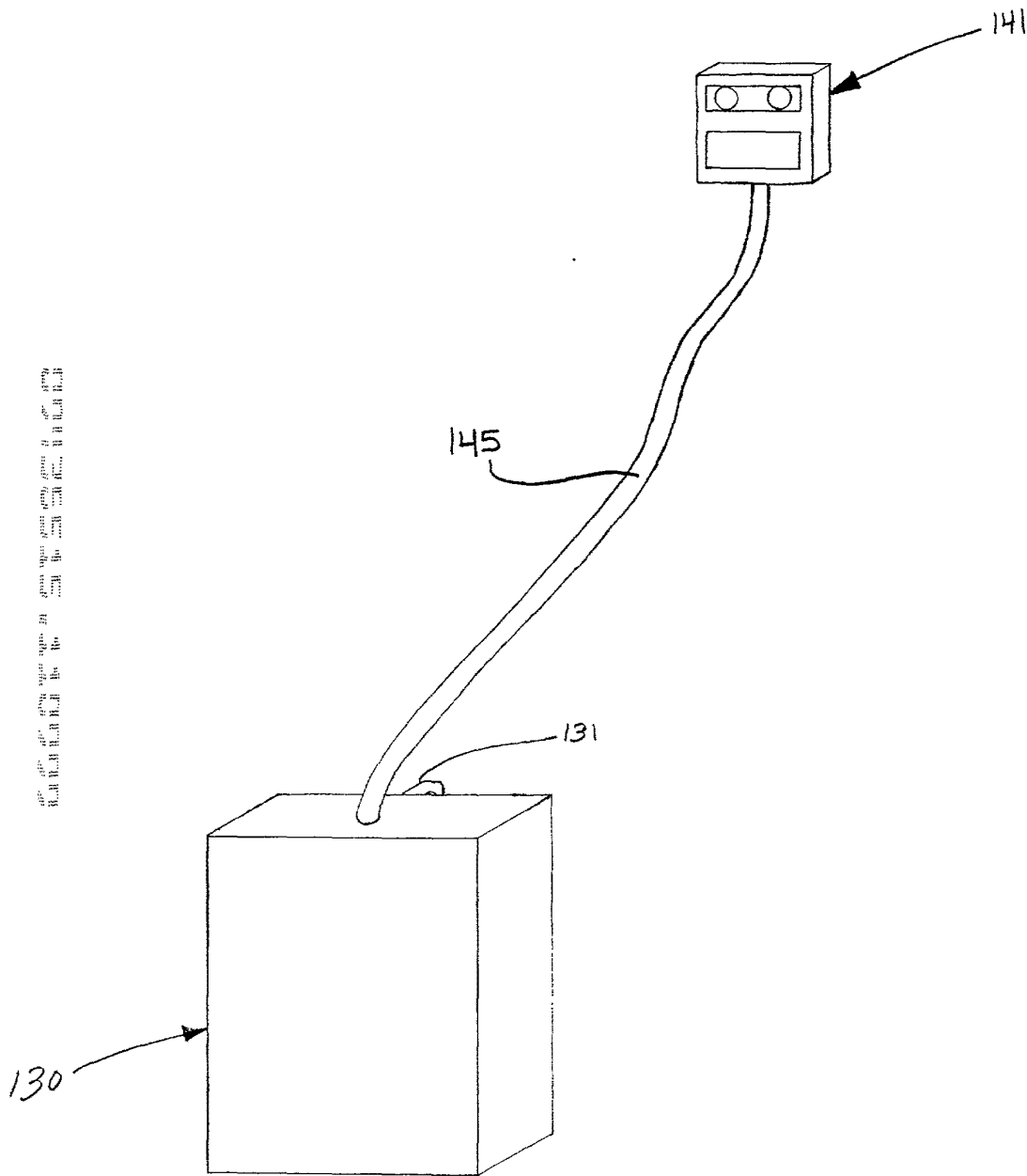

FIG. 18

02
01
00
99
98
97
96
95
94
93
92
91
90
89
88
87
86
85
84
83
82
81
80
79
78
77
76
75
74
73
72
71
70
69
68
67
66
65
64
63
62
61
60
59
58
57
56
55
54
53
52
51
50
49
48
47
46
45
44
43
42
41
40
39
38
37
36
35
34
33
32
31
30
29
28
27
26
25
24
23
22
21
20
19
18
17
16
15
14
13
12
11
10
09
08
07
06
05
04
03
02
01
00

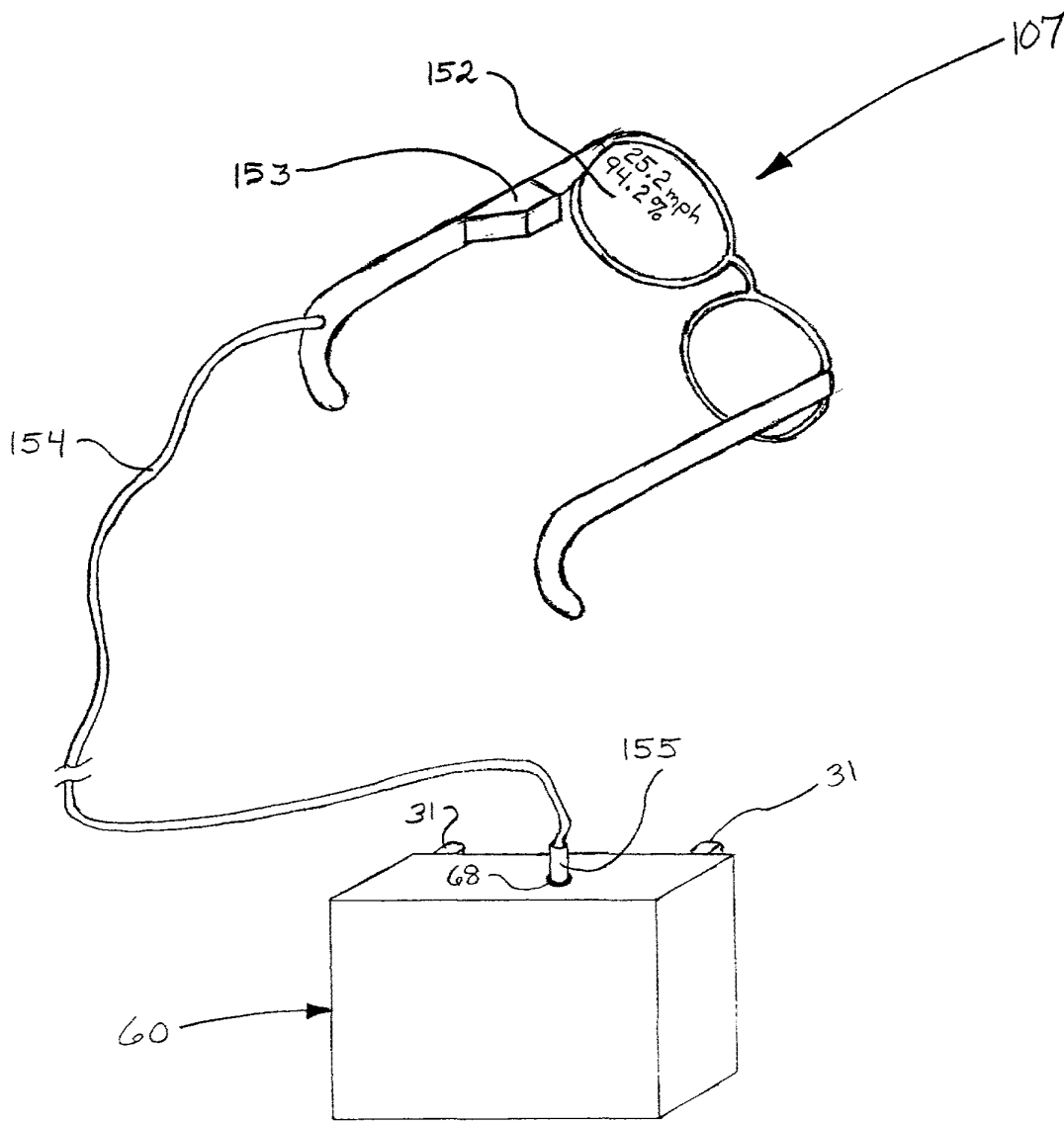

FIG. 19

DINSMORE & SHOHL LLP

66/60/TJ
11/09/99
jc674 U.S. PTO

Attorneys at Law

1900 Chemed Center
255 East Fifth Street
Cincinnati, Ohio 45202
(513) 977-8200
Fax (513) 977-8141

Martin J. Miller, Esq.
Direct Dial - (513) 977-8565
e-mail: mmiller@dinslaw.com

Columbus
(614) 628-6880
Fax (614) 628-6890

Covington
(606) 292-2502
Fax (513) 977-8141

Dayton
(937) 449-6400
Fax (937) 449-6405

Lexington
(606) 425-1000
Fax (606) 425-1099

Louisville
(502) 540-2300
Fax (502) 585-2207

www.dinslaw.com

November 9, 1999

VIA EXPRESS MAIL

BOX PATENT APPLICATION
Assistant Commissioner for Patents
Washington, D.C. 20231

jc625 U.S. PTO
09/436515
11/09/99

TRANSMITTAL OF PATENT APPLICATION

Dear Sir:

Transmitted herewith for filing is the patent application of:

Inventor(s): Jack B. Stubbs
Kevin L. Schwieger
Title: EXERCISE MONITORING SYSTEM AND METHODS
Drawings: 12 Sheets
Papers Enclosed: Specification, 58 Claims and Abstract (Total of 59 Pages);
Verified Statement Claiming Small Entity Status; and Return
Receipt Postcard
Attorney Docket No.: 24278-1

Respectfully submitted,
DINSMORE & SHOHL LLP

By Martin J. Miller
Martin J. Miller
Registration No. 35,953

CERTIFICATE OF EXPRESS MAIL

"Express Mail" mailing label number: **EL 441565630US**

Date of Deposit: November 9, 1999

I hereby certify that this paper or fee is being deposited with the United States Postal Service "Express Mail Post Office to Addressee" service under 37 CFR 1.10 on the date indicated above and is addressed to Box Patent Application, Assistant Commissioner for Patents, Washington, D. C. 20231

Martin J. Miller
Martin J. Miller

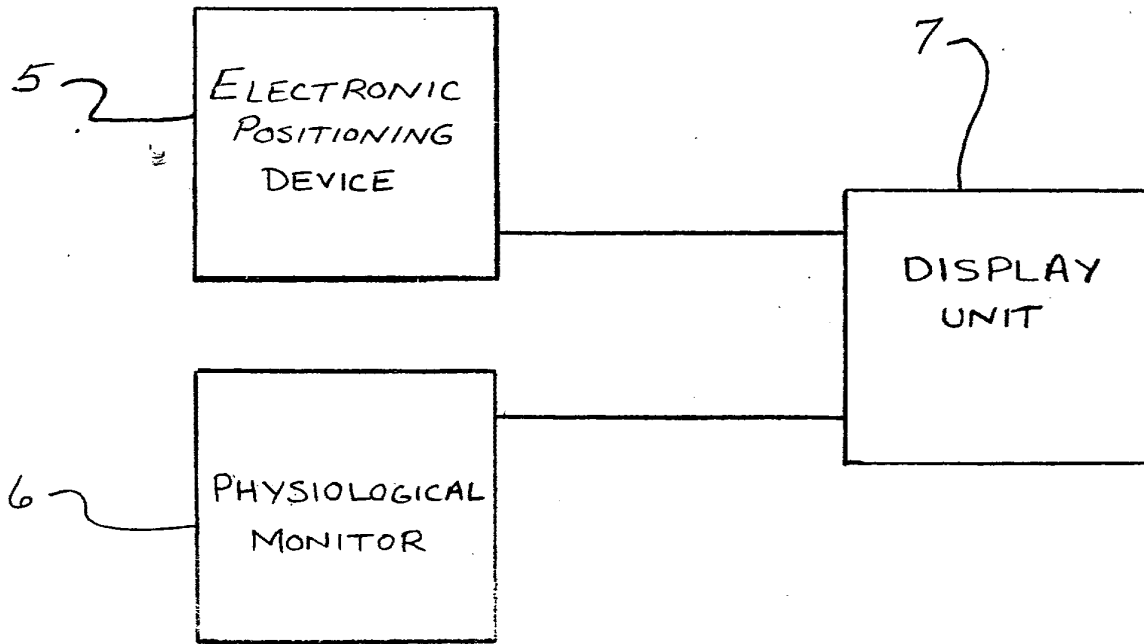

FIG. 1

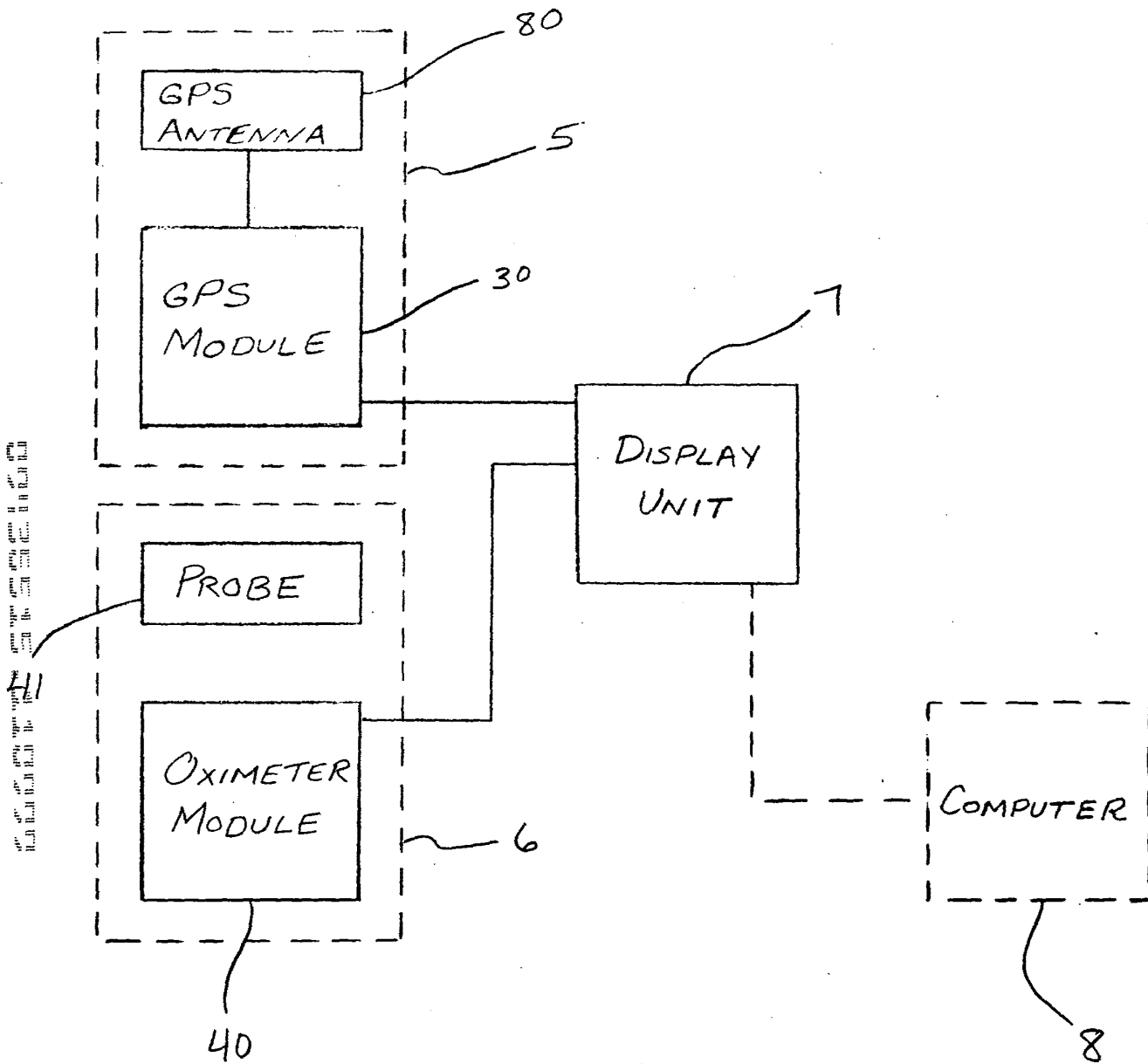

FIG. 2

FIG. 3 is a schematic diagram of a system for motion tracking. The system includes a user 20 and a set of three satellites 7. The satellites 7 are positioned in a triangular arrangement above the user 20. Arrows indicate the signal paths from each satellite 7 to the user 20. The user 20 is shown in a running posture on a ground surface, with a hatched area representing the ground. The user 20 is wearing a waist-mounted device and a wrist-mounted device. The ground surface is indicated by a horizontal line with diagonal hatching below it.

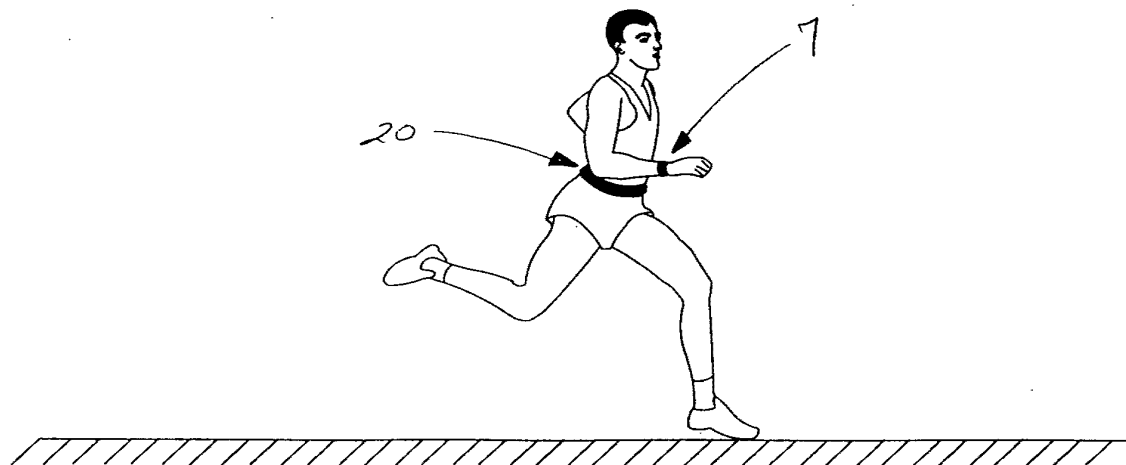
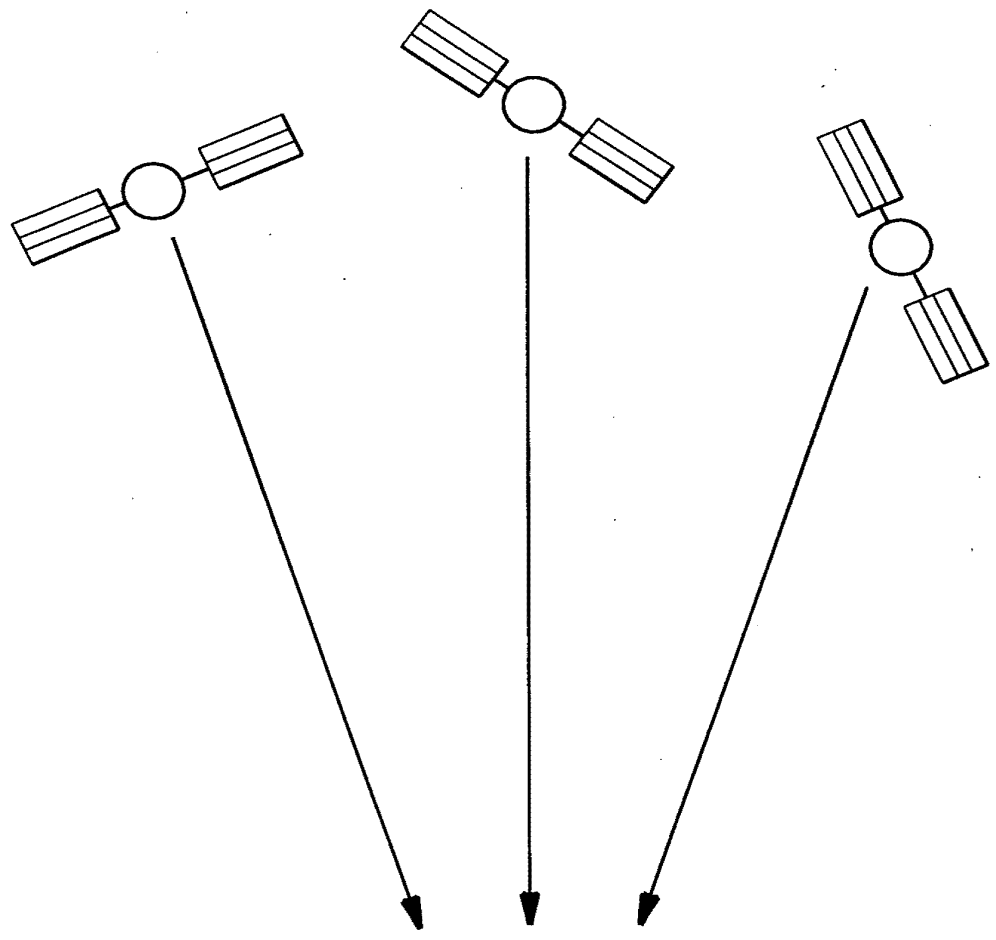
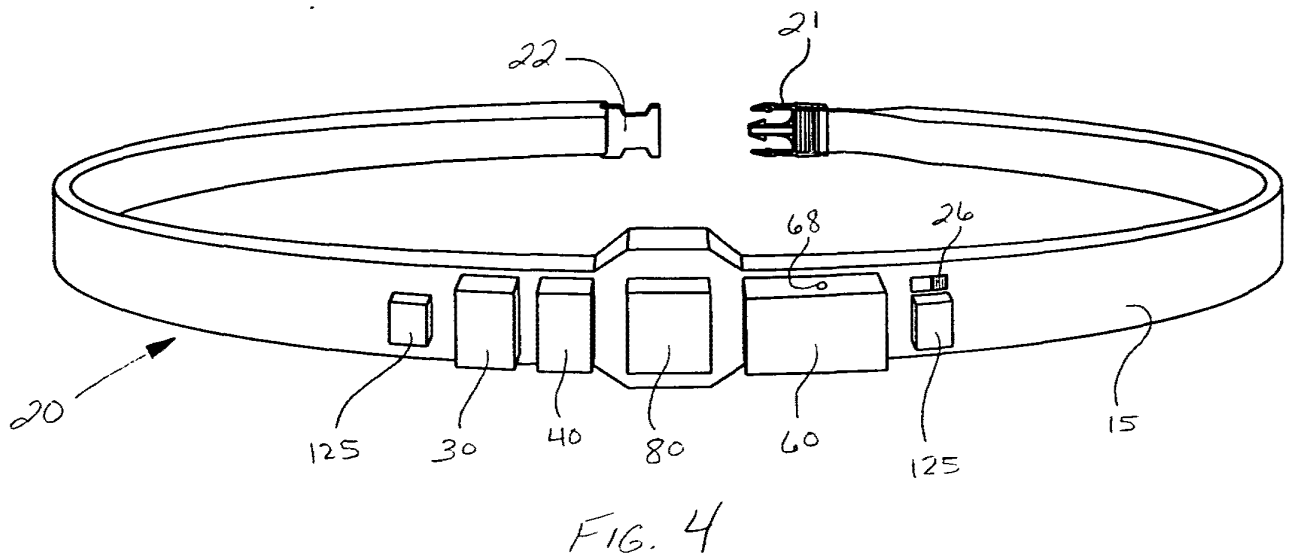
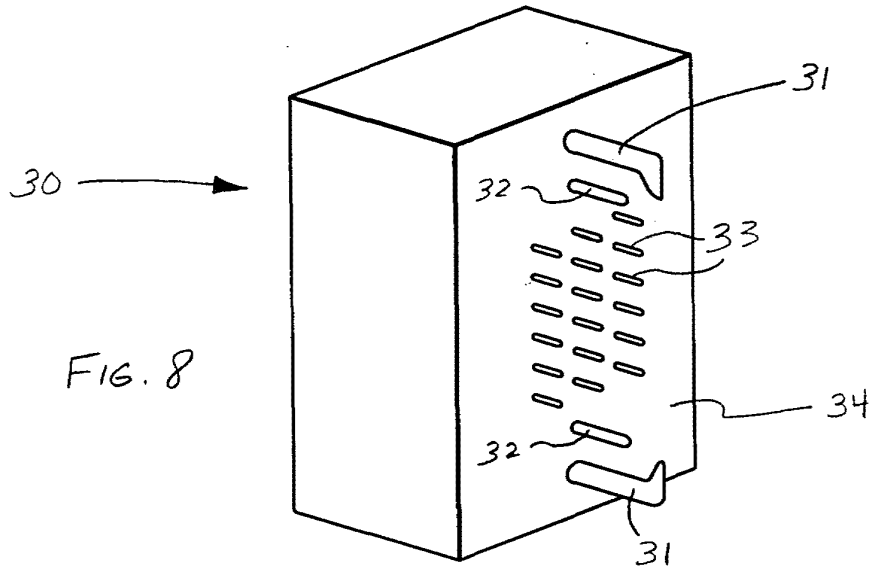
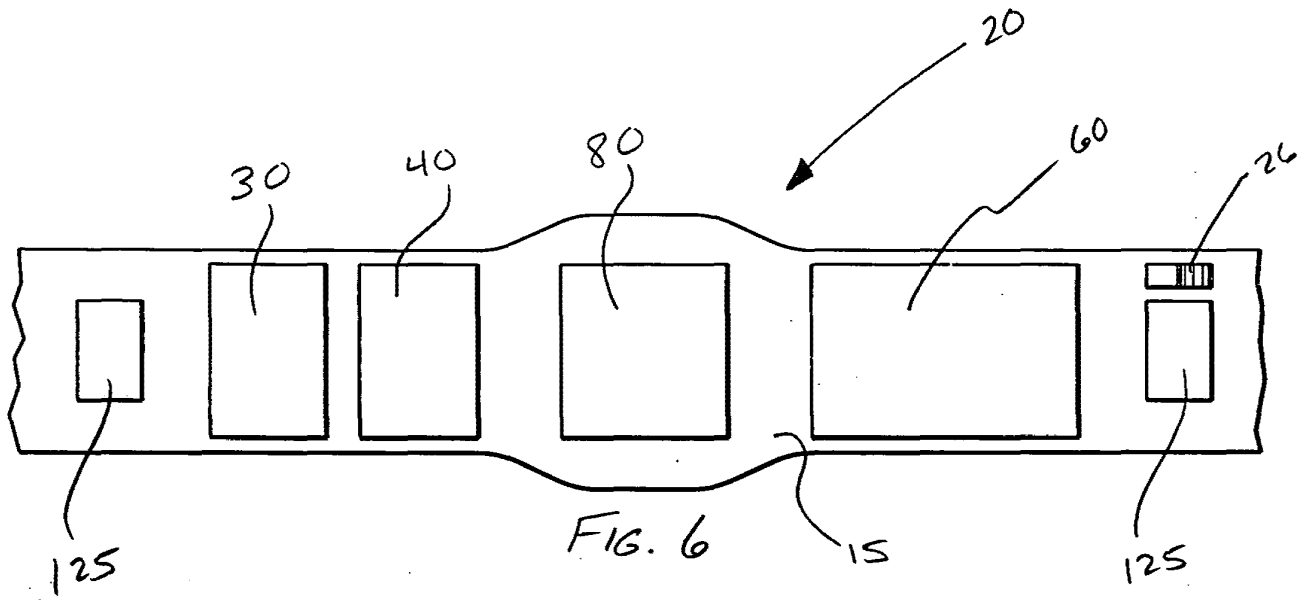

FIG. 3



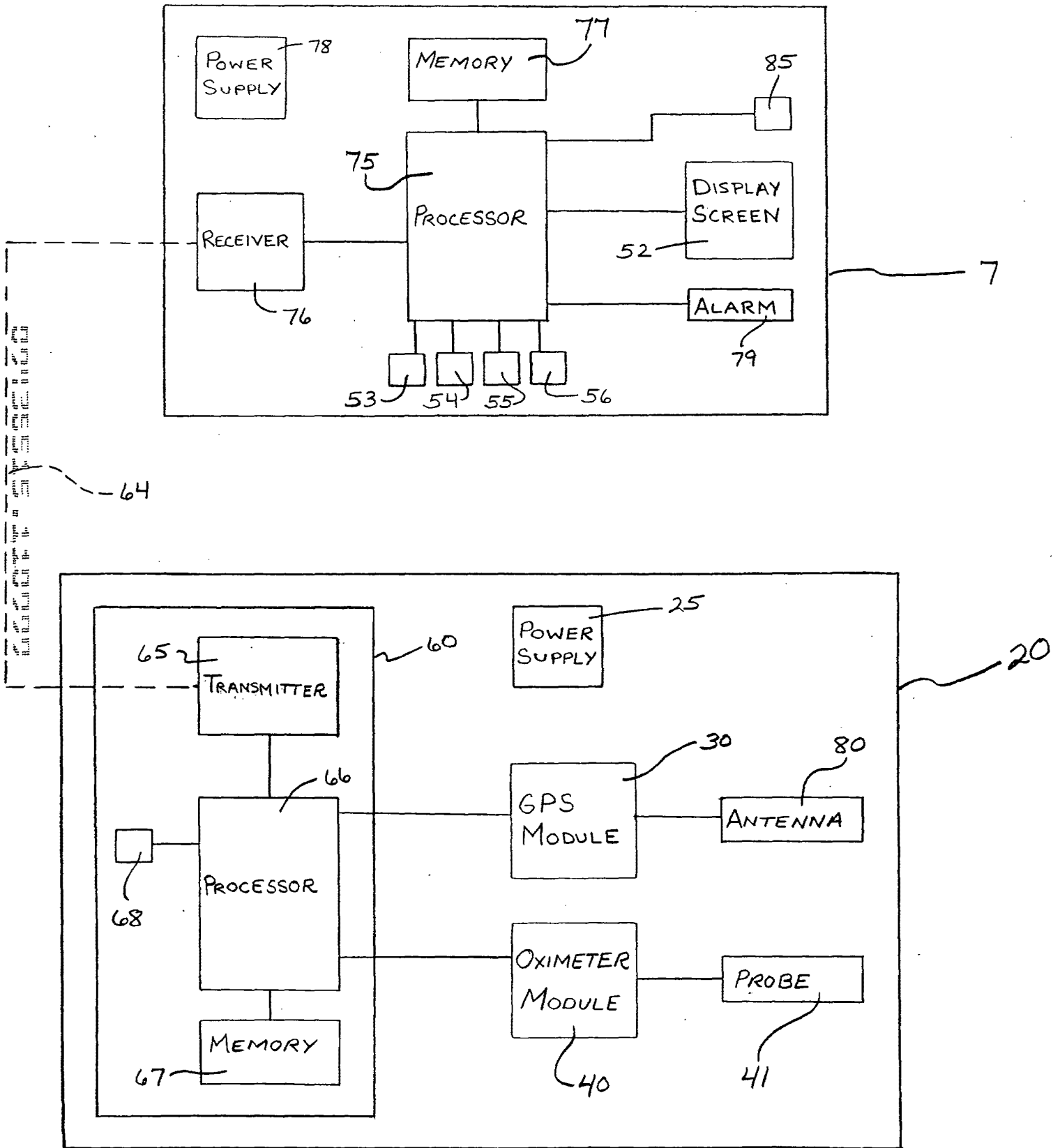
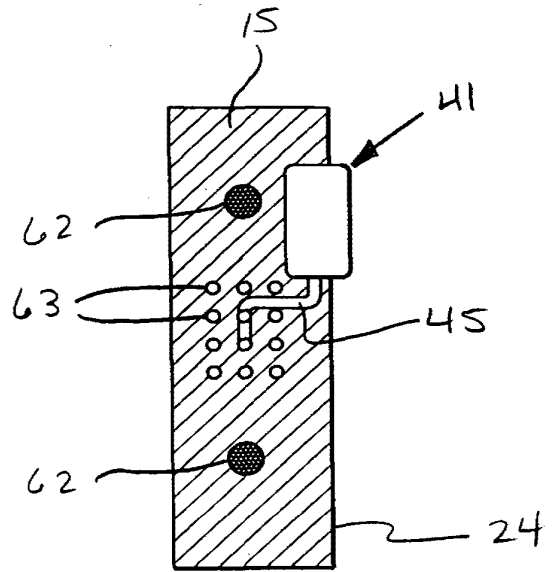
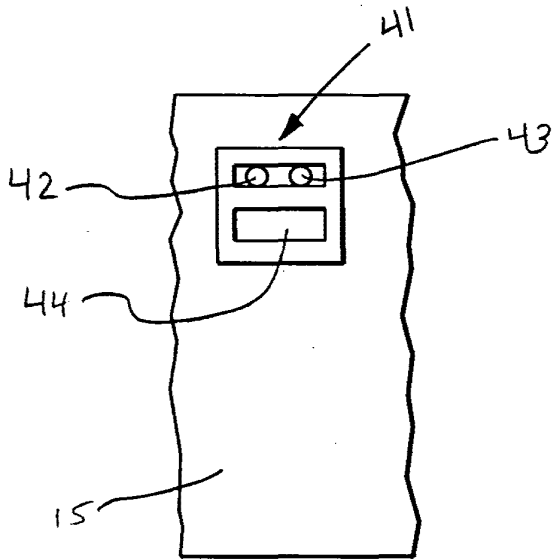
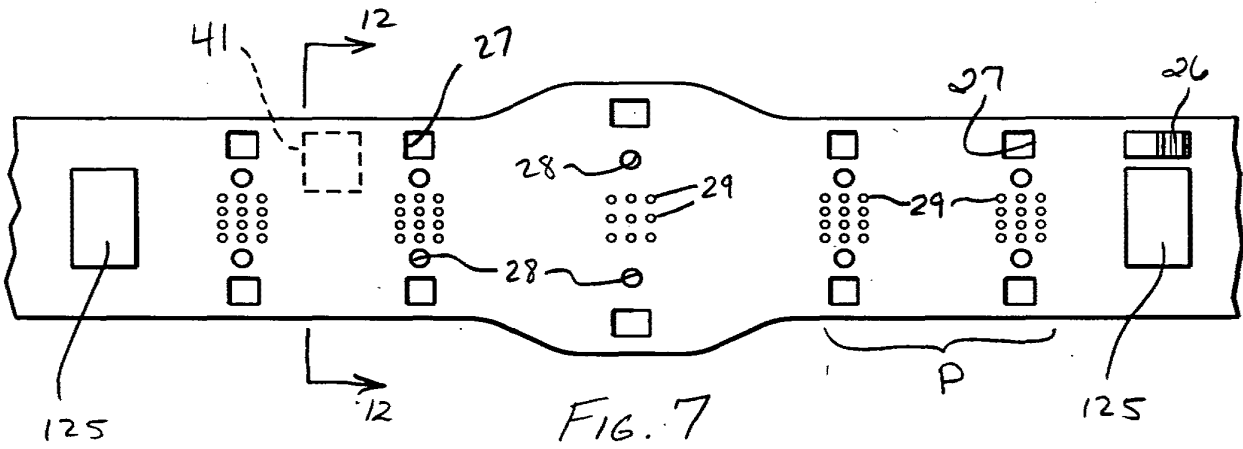

FIG. 5



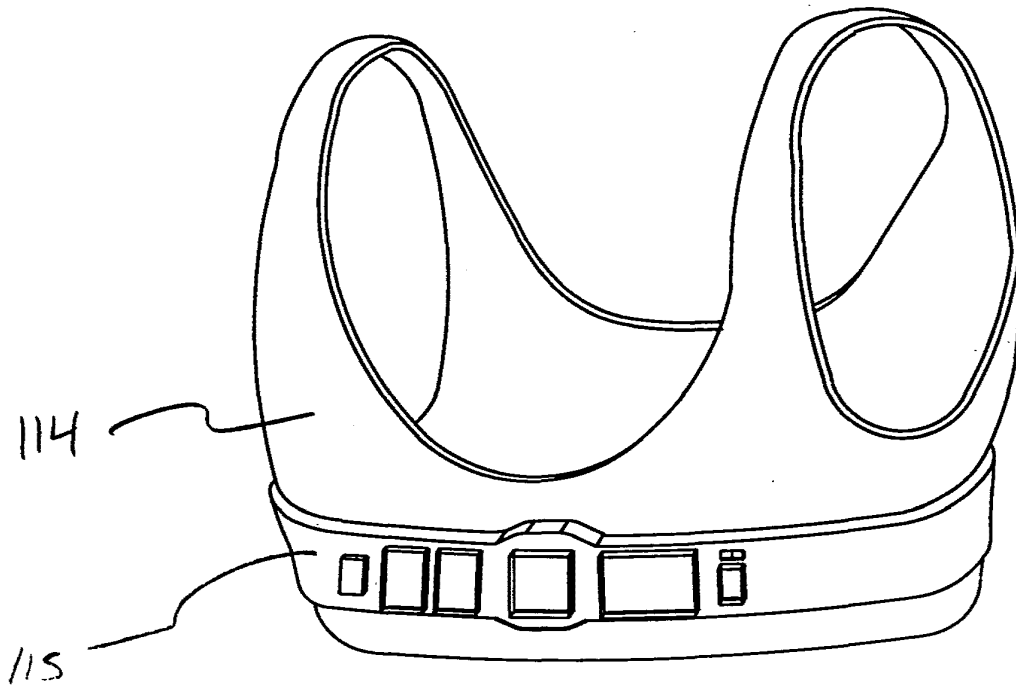

FIG. 15

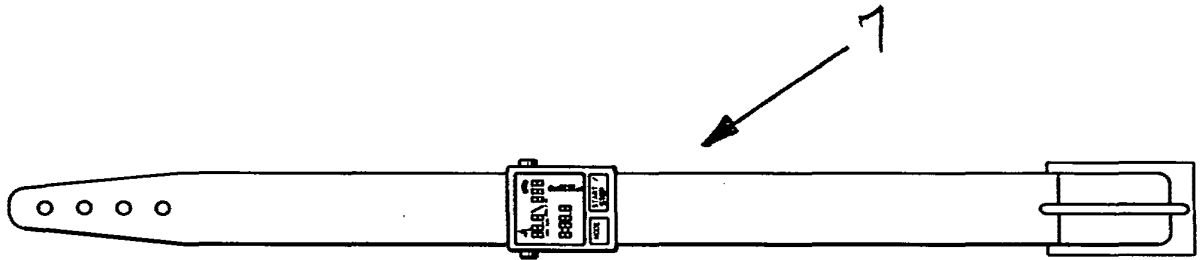

FIG. 9

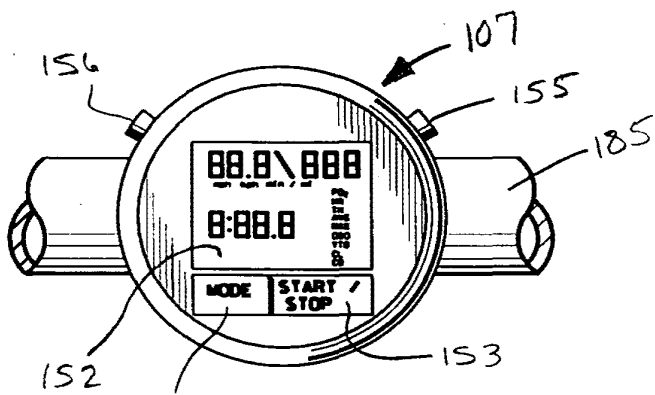

FIG. 13

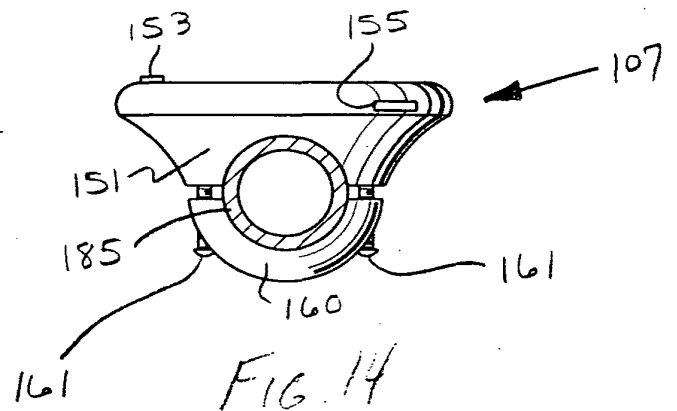

FIG. 14

11/2018 Apple Inc. Patent Application No. 15/800,000

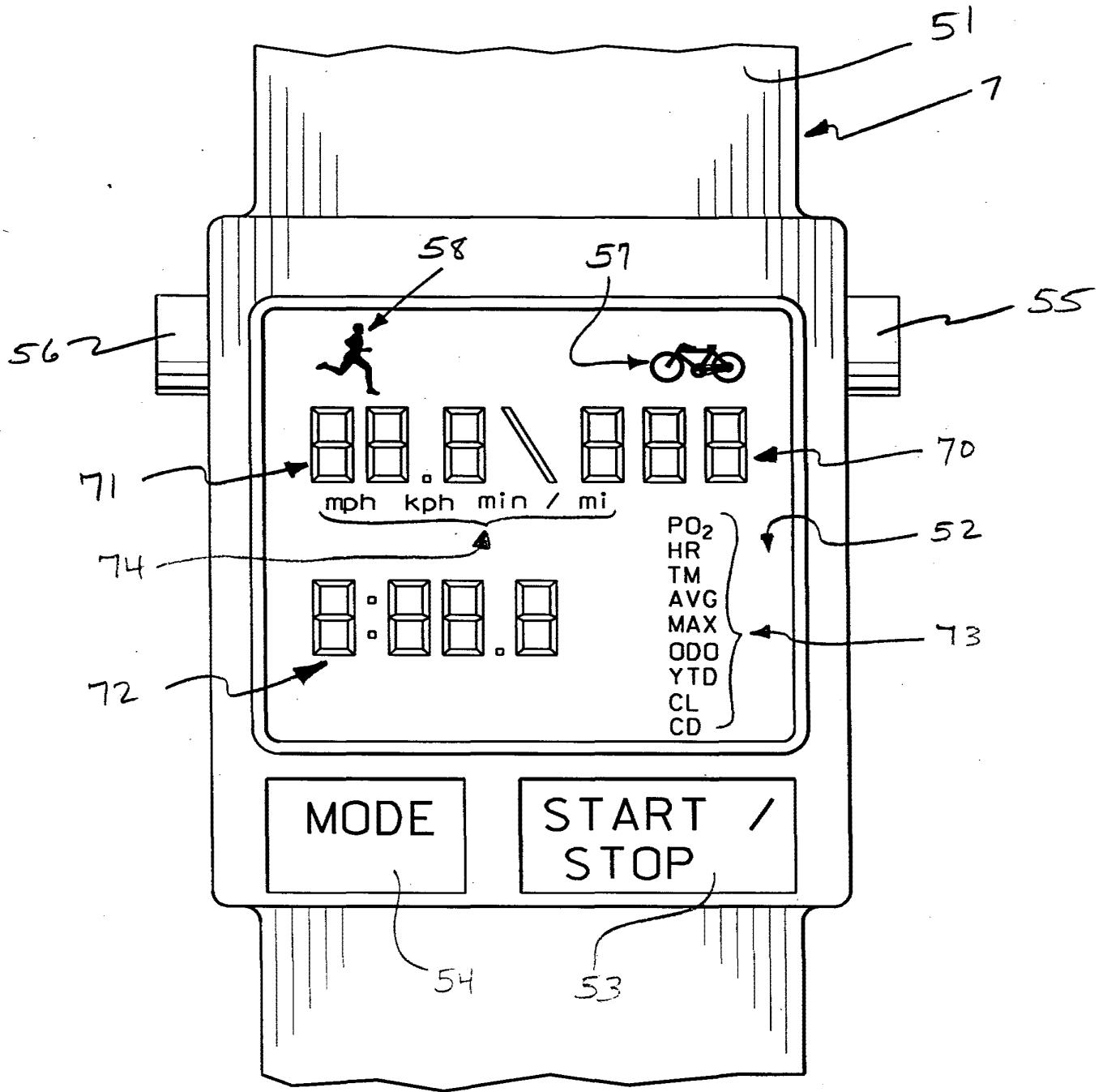

FIG. 10

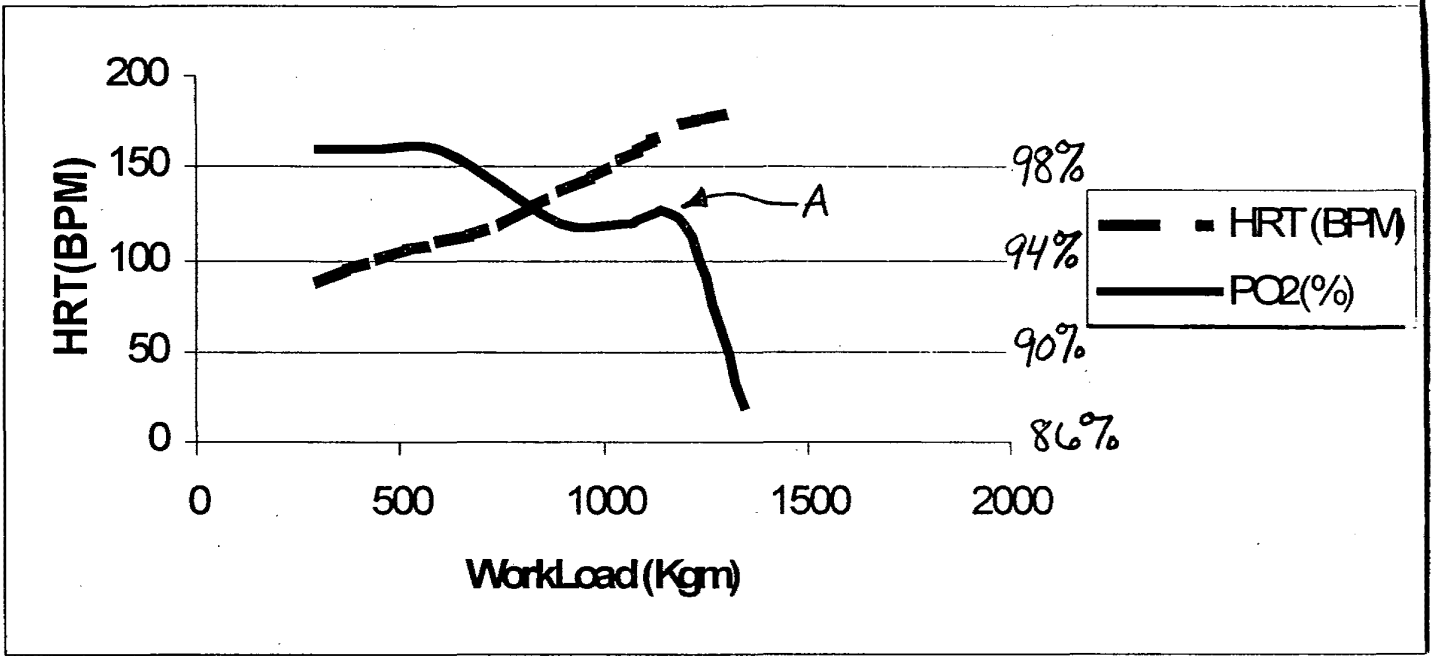

FIG. 16

1 2 3 4 5 6 7 8 9 10 11 12 13 14 15 16 17 18 19 20 21 22 23 24 25 26 27 28 29 30 31 32 33 34 35 36 37 38 39 40 41 42 43 44 45 46 47 48 49 50 51 52 53 54 55 56 57 58 59 60 61 62 63 64 65 66 67 68 69 70 71 72 73 74 75 76 77 78 79 80 81 82 83 84 85 86 87 88 89 90 91 92 93 94 95 96 97 98 99 100

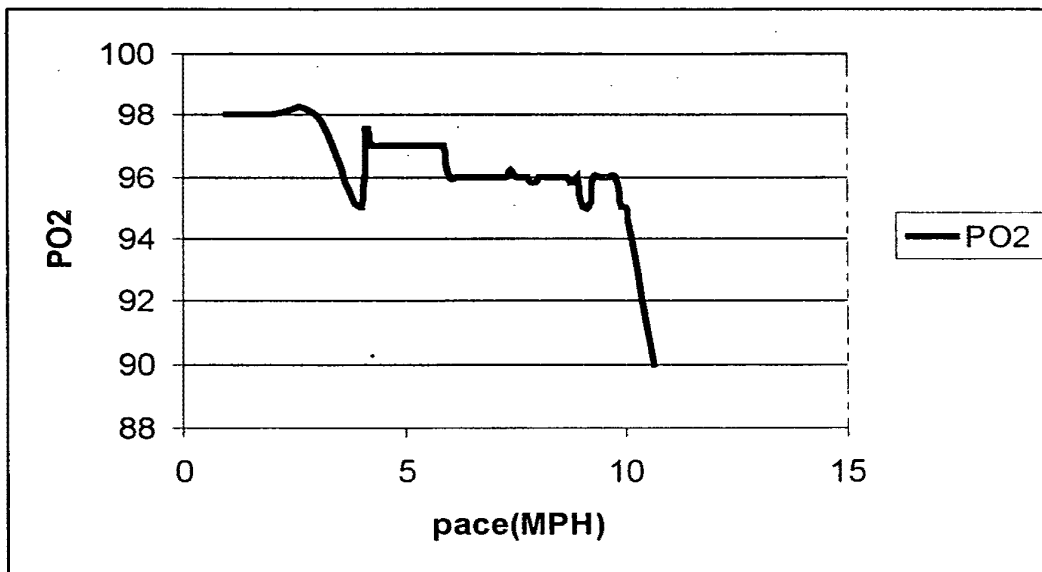
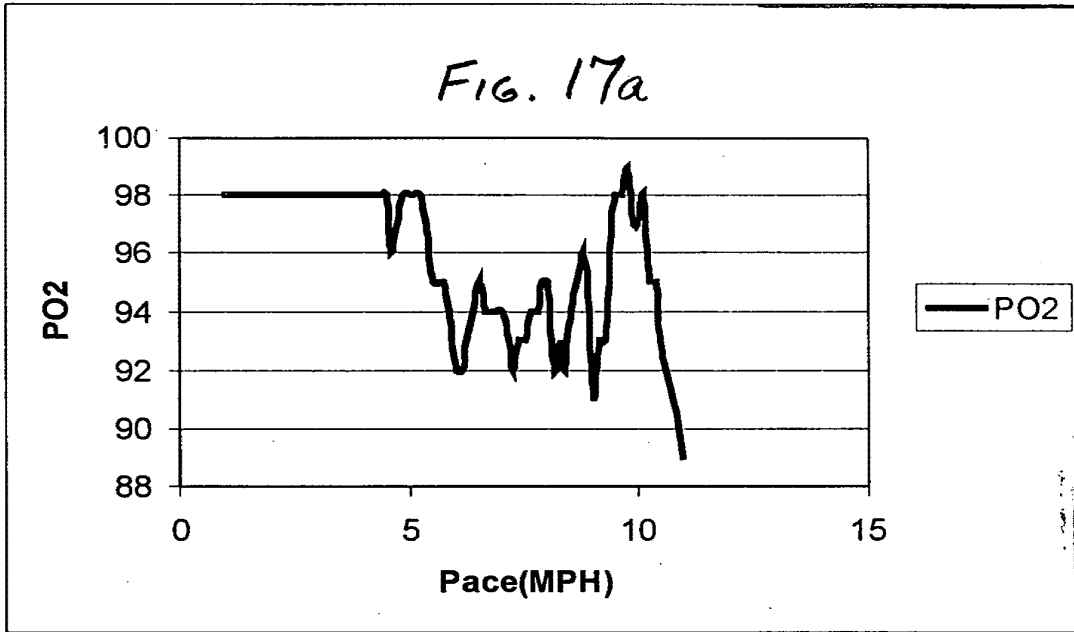

FIG. 17b

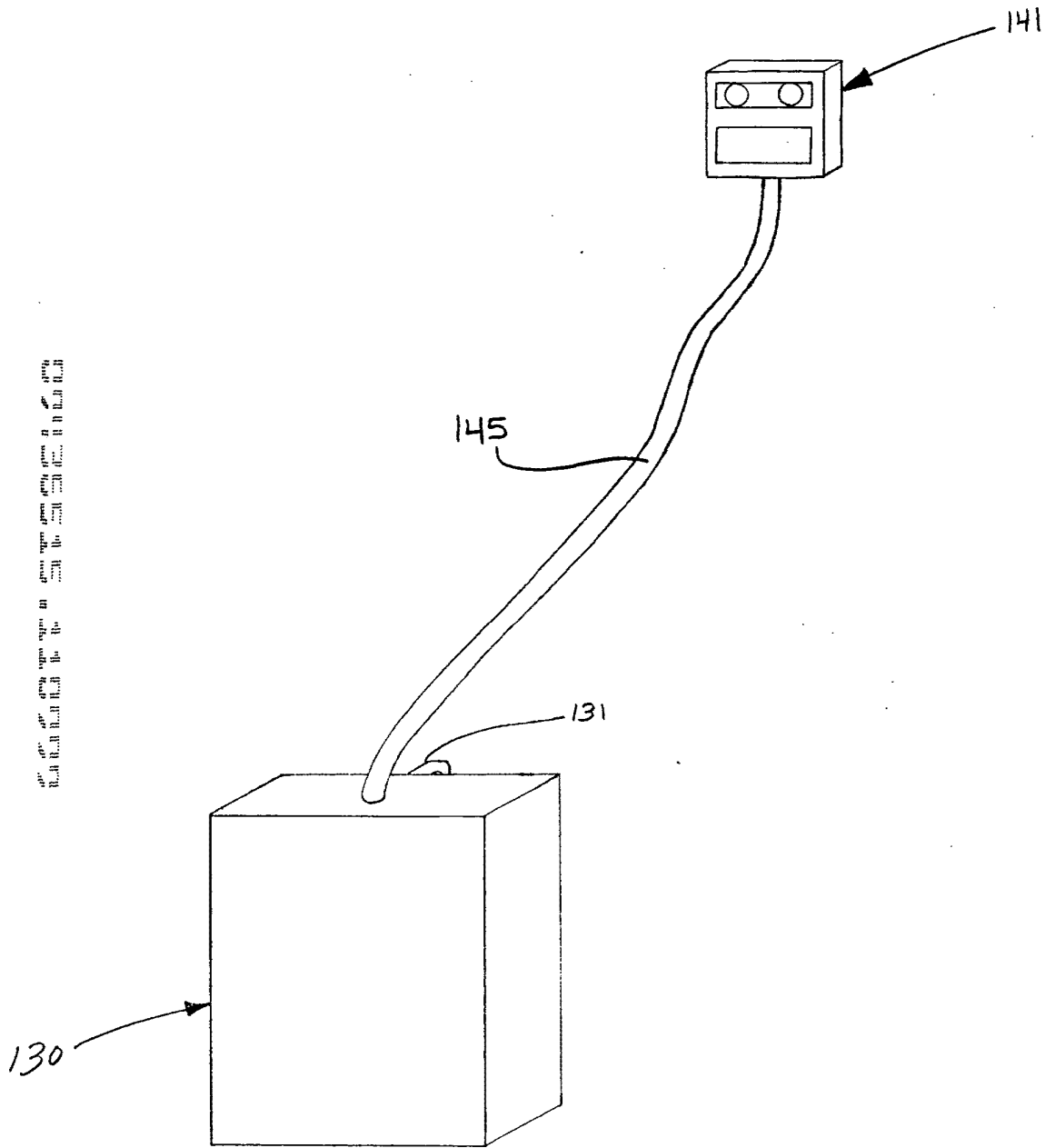

FIG. 18

ALL INFORMATION CONTAINED HEREIN IS UNCLASSIFIED EXCEPT WHERE SHOWN OTHERWISE

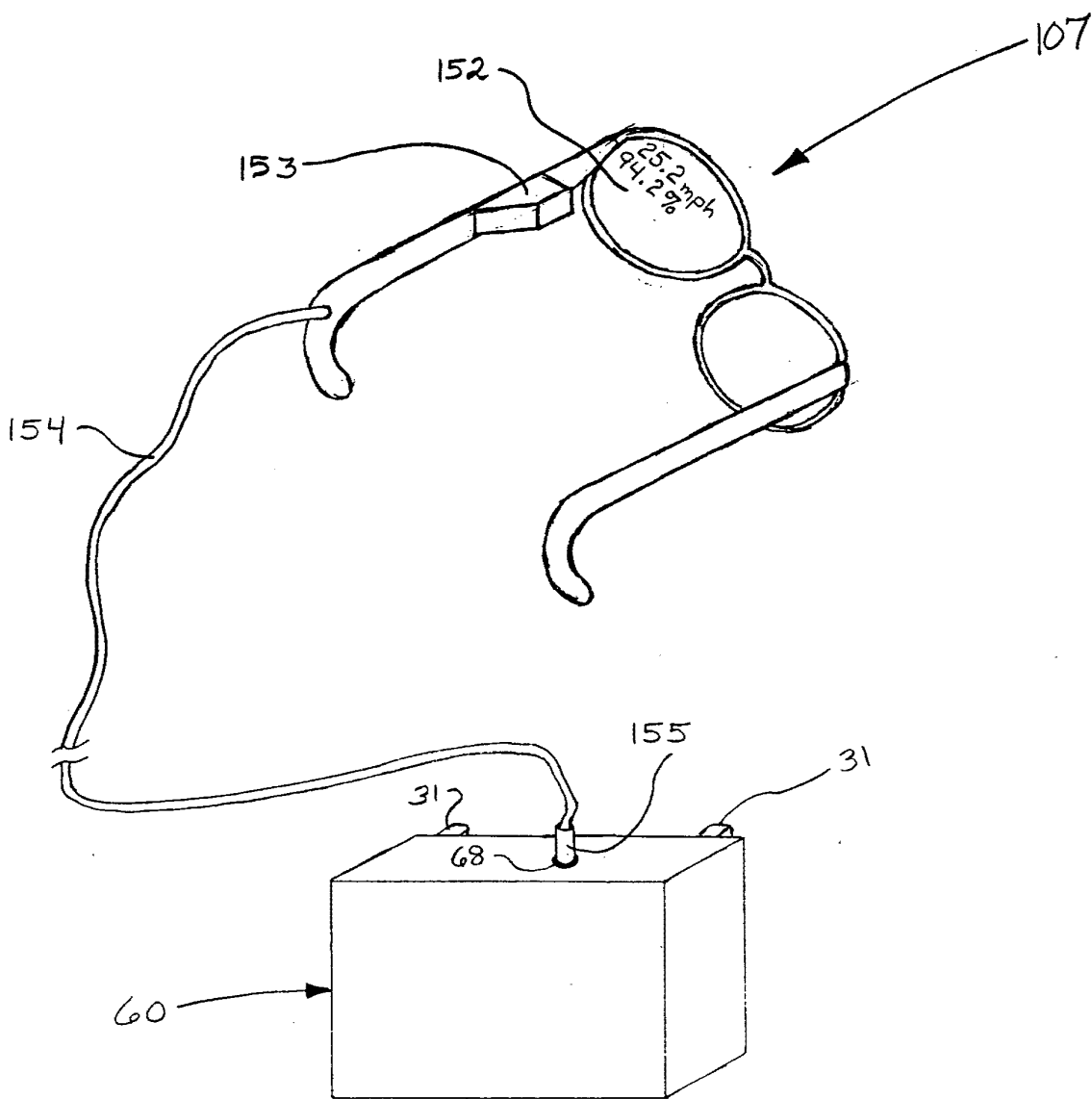

FIG. 19

DRS

CERTIFICATE OF EXPRESS MAIL

"Express Mail" mailing label number:
Date of Deposit:

I hereby certify that this paper or fee is being deposited with the United States Postal Service "Express Mail Post Office to Addressee" service under 37 CFR 1.10 on the date indicated above and is addressed to Box Patent Application, Assistant Commissioner for Patents, Washington, D.C. 20231.

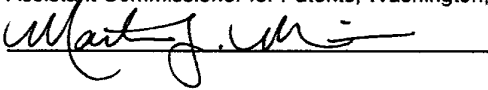

EXERCISE MONITORING SYSTEM AND METHODS

**Jack B. Stubbs
Kevin L. Schwieger**

BACKGROUND OF THE INVENTION

Field of the Invention.

5 The present invention relates to a monitoring system for use in a variety of physical activities, as well as training and analytical methods for physical activities. The present invention provides monitoring systems having an electronic positioning device and/or a physiological monitor (such as an oximeter or a heart rate monitor) in order to provide information concerning a subject performing a physical activity.

Description of Related Art.

10 Throughout the world, more and more people are exercising in order to improve their general health and physical fitness. For the average person, however, a lack of motivation can significantly hinder their efforts. In addition, the natural tendency is to try and achieve the greatest results in the shortest possible time. When typical measurements of physical fitness and progress
15 such as weight loss are monitored, however, expectations often are not met. The result can be a lack of motivation, which in turn leads to a cessation of exercise.

While athletes of all ages are usually able to overcome motivational hurdles, athletes often have difficulty in accurately measuring their progress. Human nature demands instantaneous feedback for motivation and encouragement. In addition, many athletes also do not know how to train effectively for maximal improvement. For example, competitive runners may have difficulty determining whether their pace on a particular day of training is too fast or too slow. While running on a track or treadmill may allow the runner to monitor his or her speed, speed alone is often an inadequate way to monitor optimal training levels.

5

Currently, there are essentially three methods of providing feedback to individuals engaged in a physical activity. The first, competition, can provide feedback concerning the individual's past training efforts in a particular physical activity. Competition feedback, however, is provided long after the training regimen has been completed, and therefore only allows for adjustments in subsequent training. In addition, many individuals are only interested in improving their general health and physical fitness, rather than competing against others.

10

15

Another method of providing feedback to an individual engaged in a physical activity is heart rate monitoring. Heart rate monitors have become common place in the exercise industry and entire training programs have been developed based upon the data provided by these monitors. Typically, an ECG-type sensor is worn by the individual (such as in a strap which extends about the individual's chest), and heart rate (in beats per minute) is displayed on a wrist-watch type unit. While heart rate monitoring is a useful tool, heart rate data can be difficult to interpret. In addition, many individuals often resort to standardized tables in order to determine target heart rate training zones. Such standardized tables, however, only provide generalized guidelines which may or may not be appropriate for a particular individual or a particular physical activity.

20

25

5 The third feedback technique which may be used by individuals performing a physical activity is lactate monitoring. Lactate is a byproduct of the anaerobic metabolic process by which energy is produced in the body. The amount of lactate present in an individual's bloodstream provides an indication of their level of exertion. While lactate monitoring can be a valuable tool, it requires drawing blood samples which are analyzed by an expensive, electronic device. Thus, lactate monitoring is invasive, costly, and generally only useful for experienced athletes and their coaches.

BRIEF DESCRIPTION OF THE DRAWINGS

10 Figure 1 is a schematic illustration of an exercise monitoring system according to one embodiment of the present invention;

Figure 2 is a schematic illustration of an exercise monitoring system according to another embodiment of the present invention;

15 Figure 3 depicts a human subject performing a physical activity using one embodiment of a monitoring system of the present invention;

Figure 4 is perspective view of the data acquisition component of the monitoring system depicted in Fig. 3;

Figure 5 is a schematic illustration of the monitoring system depicted in Fig. 3;

20 Figure 6 is an enlarged plan view of a portion of the data acquisition component of the monitoring system depicted in Fig. 3;

Figure 7 is a view similar to Fig. 6, wherein the modules have been removed from the support member of the data acquisition component;

Figure 8 is a perspective view of an oximeter module of the data acquisition component of the monitoring system depicted in Fig. 3;

Figure 9 is a top plan view of the display component of the exercise monitoring system depicted in Fig. 3;

5 Figure 10 is an enlarged top plan view of a portion of the display unit of Fig. 9;

Figure 11 is a rear plan view of a portion of the data acquisition component of Fig. 7;

10 Figure 12 is a cross-sectional view of the data acquisition component of Fig. 7, taken along the line 12-12 thereof;

Figure 13 depicts an alternative display unit according to an embodiment of the exercise monitoring system of the present invention, wherein the display unit is mounted to a handlebar of a bicycle;

15 Figure 14 is a side view of the display unit of Fig. 13, wherein the bicycle handlebar is shown in cross-section;

Figure 15 is a perspective view of an alternative embodiment of a data acquisition component according to the present invention, wherein the data acquisition component is configured to be worn about the chest of a human subject;

20 Figure 16 is a plot which depicts a runner's heart rate and blood oxygen level as the runner's workload is progressively increased;

Figures 17a and 17b are plots depicting a runner's blood oxygen level as the runner's pace is progressively increased;

Figure 18 is a perspective view of an alternative embodiment of an oximeter used in a monitoring system according to the present invention; and

5 Figure 19 depicts an alternative display unit of a monitoring system according to the present invention.

SUMMARY OF THE INVENTION

One embodiment of the present invention is an exercise monitoring system which comprises:

10

- a. an electronic positioning device;
- b. a physiological monitor; and
- c. a display unit (or component) configured for displaying data provided by the electronic positioning device and the physiological monitor.

15

The electronic positioning device is configured to receive electromagnetic signals from three or more sources so that the monitoring system can determine at least one of a subject's location, altitude, velocity, pace, and distance traveled. In one particular embodiment, the electronic positioning device comprises a GPS device. The physiological monitor may be chosen from the group consisting of: an oximeter and a heart rate monitor.

20

25

The electronic positioning device and the physiological monitor may be provided as part of a user-wearable data acquisition unit (or component) which is separate from the display unit. The data acquisition unit may further include a support member, wherein the electronic positioning device and the physiological monitor are provided on the support member. In one embodiment, the electronic positioning device and the physiological monitor are removably

secured to the support member. The data acquisition unit may be configured to be worn by a subject in a variety of locations, such as the subject's waist or chest. The display unit may likewise be configured in a variety of manners. For example, the display unit may be configured to be worn about a human user's wrist, or may be configured to be mounted to a bicycle (e.g., mounted to the handlebars). The display unit may also comprise an external device to which the monitoring system of the present invention transmits data. For example, the monitoring system of the present invention may be configured to display acquired data on a personal computer ("PC"), and even store the data on the PC for later retrieval and analysis. The monitoring system may also be configured to display data on a treadmill display screen so that the monitoring system will provide blood oxygen data for a subject walking or running on a treadmill.

The physiological monitor of the exercise monitoring system may include a probe (or sensor) configured for acquiring physiological data from a user. The probe may be incorporated into the data acquisition component itself (such as integrally provided on or in the support member), or may comprise a separate unit which is in electrical communication with the data acquisition component (such as by means of a wire or cable, or by means of electromagnetic wave transmission). The monitoring system may further include at least one audible or visual alarms which is activated when data provided by at least one of the electronic positioning device and the physiological monitor does not meet a predetermined target (e.g., when the user's speed, blood oxygen level or heart rate exceeds or falls short of a predetermined target).

Another embodiment of the present invention is an exercise monitoring system which comprises:

- a. an electronic positioning device configured to receive electromagnetic signals from three or more sources so that the monitoring system can determine a subject's velocity or pace;

- b. a display unit configured for displaying data provided by the electronic positioning device; and
- c. an alarm, wherein the alarm is activated when a subject's velocity or pace does not meet a predetermined target.

5 The electronic positioning device in this embodiment may comprise a GPS device.

Yet another embodiment of the present invention is an exercise monitoring system which comprises:

- a. an oximeter configured to determine a subject's blood oxygen level;
- b. a display unit configured for displaying the subject's blood oxygen level; and
- c. an alarm, wherein the alarm is activated when the subject's blood oxygen level does not meet a predetermined target.

10

15

By way of example, the oximeter may comprise an oximetry probe and oximeter module, which are configured to acquire blood oxygen data by light absorption techniques. Preferably, the oximeters described herein are configured and positioned to determine systemic blood oxygen levels, rather than the blood oxygen level of targeted tissues or regions.

20

Another embodiment of the present invention is a method of controlling a subjects physical activity, comprising:

- a. monitoring a subject's blood oxygen level while the subject performs a physical activity; and
- b. maintaining the blood oxygen level at a selected level while the subject continues to perform the physical activity.

25

The subject may be human or animal (particularly horses, dogs, camels, and other mammals), and the monitoring step may even utilize the exercise monitoring systems described herein. It should be pointed out, however, that blood oxygen data may also be acquired using conventional, readily-available

5

oximeters. This method of controlling a subject's physical activity may be performed solely by the subject, or may involve another (such as a coach or trainer). In one particular embodiment, the method of controlling a subject's physical activity even provides a training method for athletes and the like using blood oxygen data.

10

The subject's blood oxygen level may be maintained at the selected level by adjusting the workload of the physical activity as necessary. In fact, the exercise monitoring systems described above may even be used for this purpose, since embodiments of the monitoring system can be configured for computing and displaying the subject's workload (based on the subject's velocity and weight, and optionally based on elevational changes). The subject's blood oxygen level may also be maintained at the selected level by adjusting the subject's level of exertion as necessary. As yet another alternative, the subject's blood oxygen level may be maintained at the selected (or predetermined) level by adjusting the subject's oxygen intake as necessary (e.g., by altering breathing patterns or methods, or by restricting or expanding oxygen or air intake). In fact, by limiting oxygen intake in order to reduce the subject's blood oxygen level, athletic training (e.g., running or biking) at high altitude may be simulated.

15

20

The method of controlling a subject's physical activity is suitable for a variety of activities, including: walking, running, swimming, bicycling, skating, singing, skiing, boating, climbing, wheelchairsing, snowshoeing, scuba diving, and flying. The step of monitoring blood oxygen level may comprise:

25

- (a) providing an oximeter, the oximeter including a probe for non-invasively determining blood oxygen level (such as through light absorption measurements); and
- (b) positioning the probe on the subject at a location suitable for detecting the subject's blood oxygen level.

Preferably, the probe is positioned such that the oximeter determines the subject's systemic blood oxygen level. The probe location may be chosen from

the group consisting of the subject's back (particularly the subject's lower back), head, arm, leg, chest and torso.

It should be noted that the selected (or predetermined) blood oxygen level may comprise a range or a target "setpoint". In fact, multiple predetermined blood oxygen levels may be employed, such that the subject's blood oxygen level is sequentially maintained at multiple selected levels (i.e., interval training). The subject's blood oxygen level may be maintained at each selected level:

- (a) for a predetermined period of time;
- (b) until the subject has advanced a predetermined distance (e.g., as measured by a GPS system); or
- (d) until the subject has performed a predetermined amount of work (e.g., as measured by a GPS system).

Each selected (or predetermined) blood oxygen level may be chosen on the basis of blood oxygen data previously obtained while the subject performed a physical activity. For example, the subject's blood oxygen level at a lactate threshold ("LT") may be determined. Thereafter, each selected blood oxygen level may be chosen on the basis of the subject's LT (e.g., at LT, or a predetermined percentage of LT). Alternatively, each selected level may be chosen on the basis of the duration of the physical activity. For example, the selected blood oxygen level may be higher when the duration of the activity is greater.

In order to facilitate the method of controlling the subject's performance of a physical activity, an alarm may be provided. The alarm may be configured to indicate (i.e., provide an audible and/or visible indicia) when the subject's blood oxygen level is not at the selected level (e.g., outside of a selected range, or not within a certain percentage of a setpoint). A display unit configured for displaying the subject's blood oxygen level may also be provided in order to facilitate performance of the method of controlling. When the subject is a human, the display unit may be configured to display blood oxygen data to the

subject or to another (such as a coach or trainer monitoring the subject's performance). For animal subjects, the display unit may be configured to display blood oxygen data to an individual such as a trainer or, in the case of horses and camels, a jockey.

5 It will be appreciated that the exercise monitoring systems of the present invention may be used for the methods of controlling a subject's performance of a physical activity described herein. In fact, the subject's velocity, pace, workload, and/or distance traveled may be measured by an electronic positioning device provided on the exercise monitoring system.

10 Still another embodiment of the present invention comprises a method of reducing a subject's blood oxygen level variability while the subject performs a physical activity, comprising:

- a. periodically measuring a subject's blood oxygen level while the subject performs a physical activity; and
- 15 b. adjusting the manner in which the physical activity is performed in order to reduce blood oxygen level variability.

The time variability of the subject's blood oxygen level may also be indicated (e.g., displayed) to the subject. The time variability of blood oxygen level may be quantified in a variety of manners, such as the standard deviation of the
20 subject's blood oxygen level. The monitoring systems of the present invention may even be configured to activate an alarm when the time variability exceeds a predetermined level.

A method of determining a fitness indicator of a subject is also provided, wherein this method comprises:

- 25 (a) recording a subject's blood oxygen level while the subject performs a physical activity;

- (b) varying the subject's workload (e.g., periodically increasing workload) while continuing to record the subject's blood oxygen level; and
- (c) determining a fitness indicator of the subject on the basis of the recorded blood oxygen data.

5

The fitness indicator may comprise, for example, the subject's lactate threshold or VO2max (the milliliters of oxygen consumed per kilogram of body weight per minute). The subject's velocity (and optionally altitude) may be measured by a GPS device, such that the subject's workload may then be determined using velocity (and optionally altitude) measurements provided by the GPS device.

10

A method of stabilizing blood oxygen levels while exercising is also provided, and comprises:

- (a) monitoring the level of blood oxygen while exercising;
- (b) adjusting breathing while continuing to exercise in order to stabilize the level of blood oxygen.

15

Another embodiment of the present invention comprises a method of comparing a subject's physical fitness to their physical fitness on a previous occasion, comprising:

- (a) measuring an individual's blood oxygen level while the individual performs a physical activity at a predetermined workload, velocity or pace; and
- (b) measuring the individual's blood oxygen level on a subsequent occasion while the individual performs the physical activity (particularly at the same predetermined workload, velocity or pace).

20

25

For example, if the subject's blood oxygen level (e.g., the subject's average blood oxygen level) is higher on a subsequent occasion, the subject's fitness will have been improved.

DETAILED DESCRIPTION OF THE PREFERRED EMBODIMENTS

5 The present invention provides an exercise monitoring system, as well as training and analytical methods useful for subjects (both human and animal) performing physical activities. The systems and methods of the present invention, for example, provide real-time data and feedback useful to individuals performing a physical activity (such as athletes). The monitoring system may include an electronic positioning device (such as a GPS device) and/or a physiological monitor (such as an oximeter or a heart rate monitor).

10 The electronic positioning device uses electromagnetic signals from three or more sources in order to provide data indicative of one or more of the subject's location, altitude, velocity, pace and/or distance traveled. By way of example, the electronic positioning component may comprise a GPS device which utilizes signals from satellites of the Global Positioning System (i.e., "GPS") in order to provide real-time data concerning at least one of the subject's
15 location, altitude, heading, velocity, pace and distance traveled, and may optionally provide a precise time measurement.

The physiological monitor may comprise an oximeter which measures the subject's blood oxygen level, and may also measure the subject's heart rate. Alternatively, the physiological monitor may comprise a heart rate monitor which
20 measures the subject's heart rate.

One embodiment of the monitoring system of the present invention includes both an electronic positioning device and a physiological monitor (such as an oximeter or heart rate monitor) as part of an integrated monitoring system. Such an integrated monitoring system allows velocity, pace, and/or distance
25 traveled information provided by the electronic positioning device to be used in conjunction with data provided by the physiological monitor. In this manner,

exercising subjects can monitor, control and/or analyze their performance while exercising at any location (e.g., outside of a laboratory).

5 The present invention also provides analytical and training methods which utilize data provided by: (a) a physiological monitor; (b) an electronic positioning device (such as a GPS device); or (c) the combination of an electronic positioning device and a physiological monitor (such as a heart rate monitor or an oximeter). It should be pointed out that the various analytical and training methods of the present invention do not require the use of the exercise monitoring systems of the present invention. However, the exercise monitoring systems of the present invention may be configured for implementation of the analytical and training methods described herein.

10 The monitoring systems, as well as the analytical and training methods, provided by the present invention may be used on both human and animal subjects. Hence, the term "subject" is intended to encompass both humans and animals. By way of example, embodiments of the exercise monitoring systems of the present invention may be used for the testing and/or training of horses and other animals typically involved in racing sports (including dogs and camels). Of course, these methods can also be used in the testing and/or training of other animals not necessarily involved in racing sports (such as rehabilitating an injured animal by putting the injured animal through a training program).

15 Figure 1 is a schematic illustration of one embodiment of an exercise monitoring system according to the present invention. The system of Fig. 1 generally comprises an electronic positioning device 5 and a physiological monitor 6, both of which are in electrical communication with a display unit 7. Electronic positioning device 5 is configured to receive electromagnetic signals from three or more sources so that the monitoring system can determine (and display by means of display unit 5) at least one of a subject's location, altitude,

heading, velocity, pace, and distance traveled. By way of example, electronic positioning device 5 may be configured to receive electromagnetic signals, and process those signals in order to determine at least one of a subject's location, altitude, heading, velocity, pace, and distance traveled. The determined data may then be transmitted to display unit 7 for display to the subject or other individual monitoring the subject's performance of a physical activity. Similarly, physiological monitor 6 is configured to acquire physiological data from the subject for display by means of display unit 5. By way of example, physiological monitor 6 may be configured to determine one or more physiological indicia (such as the subject's blood oxygen level or heart rate). The determined physiological indicia may then be transmitted to display unit 7 for display to the subject or other individual monitoring the subject's performance of a physical activity.

Figure 2 schematically depicts a more specific embodiment of an exercise monitoring system according to the present invention. In the embodiment of Fig. 2, electronic positioning device 5 comprises a GPS device which includes a GPS antenna 80, and a GPS module 30. Physiological monitor 6 comprises an oximeter which includes a probe 41, and an oximeter module 40. Display unit 7 may comprise any of a variety of structures configured for displaying data. For example, a simple display unit may include a screen which displays the subject's speed (e.g., in miles per hour) and blood oxygen level (e.g., in terms of the percentage of oxygen saturation). The display unit may optionally be configured for linking to (e.g., in electrical communication with) a computer 8 (such as a personal computer of "PC"). Such linking may be provided by a cable, in infrared link, or other means well-known to those skilled in the art. In this manner, data may be stored in computer 8 for later retrieval and analysis.

An exercise monitoring system according to the present invention may comprise a single structure, or may be subdivided into one or more component structures. Thus, one embodiment of the present invention includes a data

acquisition component and a separate data display component (i.e., display unit) which are in electrical communication with each other through a wired link (e.g., and electrical cable) or a wireless link (e.g., via radio wave transmission). The data acquisition component may include at least one of an electronic positioning device and a physiological monitor, and may be configured to be worn by a subject performing a physical activity.

A variety of configurations may be provided for the data acquisition component, depending in part upon the nature of the physical activity to be performed as well as the type of data to be acquired. For example, a physiological monitor will often include a sensor or probe which interacts with the subject to acquire physiological data (such as heart rate and/or blood oxygen level). The physiological sensor or probe may be incorporated into the data acquisition component, or may be provided as a separate unit which is in communication with the data acquisition component. For example, the physiological sensor or probe may be remote from the data acquisition component, yet in electrical communication with the data acquisition component over a wired or wireless connection (see, e.g., Fig. 18). When the sensor or probe is incorporated into the data acquisition component itself, the data acquisition component may be configured to ensure proper positioning of the sensor or probe on the subject (i.e., in a position operable to acquire the desired physiological data). Of course, the data acquisition component of a monitoring system according to the present invention may even comprise multiple structures which are physically separate from each other.

The data display component may likewise be provided in a variety of configurations, and its configuration may even be chosen based upon the particular physical activity to be performed. By way of example, the display component may be worn by the subject, worn by another individual, attached to an apparatus associated with the physical activity (e.g., mounted on a bicycle), or provided as a separate, standalone unit.

Figure 3 depicts a human subject performing a physical activity, namely running, using a monitoring system according to one embodiment of the present invention. In the monitoring system depicted in Fig. 3, the data acquisition component is depicted at 20, and is worn about the subject's waist. The data display component is depicted at 7, and is worn about the subject's wrist. While the system shown in Fig. 3 provides separate data acquisition and data display components, it will be understood that these two components can be provided in a single structure. In addition, the configuration of data acquisition component 20 and data display component 7 in Fig. 3 is merely exemplary of one embodiment of a monitoring system according to the present invention. The structural features of the specific embodiment of the monitoring system of Fig. 3 will be further described below, after the electronic configuration has been described.

As mentioned previously, the data acquisition component of the monitoring system of the present invention may include an electronic positioning device and/or a physiological monitor (such as an oximeter or a heart rate monitor). In the schematic illustration of an exemplary monitoring system in Fig. 5, data acquisition component 20 includes both an electronic positioning device and a physiological monitor. In the embodiment of Fig. 5, the electronic positioning device comprises a GPS device which may include a GPS antenna 80 and a GPS processing module 30. As further detailed below, antenna 80 receives GPS satellite signals, and signal output from antenna 80 is processed by GPS processing module 30 in order to provide an electrical signal which includes, for example, data indicative of the user's location. Data from GPS module 30 is provided to processor/transmitter module 60 where it may be further processed and then transmitted to display component 7 over link 64.

It should be noted that the electronic positioning device used in embodiments of the monitoring system of the present invention is not limited to a GPS device. Thus, the term electronic positioning device is intended to be

inclusive of devices which receive electromagnetic signals from three or more sources, and thereafter process those signals in order to provide data indicative at least one of the subject's location, altitude, heading, velocity, pace and distance traveled. For example, an electronic positioning device which detects radio wave and/or microwave signals from at least three sources may be used, wherein the received signals are processed in a manner similar to the processing of GPS signals in order to determine the subject's location, altitude, heading, velocity, pace and/or distance traveled. Even signals from cellular phone towers may be employed. In addition, the term "GPS device" is intended to include devices which utilize signals received from satellites of the Global Positioning System developed by the United States Department of Defense, as well as systems which utilize signals received from satellites of the Global Orbiting Navigation Satellite System ("GLONASS") developed by the former Soviet Union (or any other satellite-based positioning system which receives and processes electromagnetic signals from three or more satellites).

Data acquisition component 20 of Fig. 5 also includes a physiological monitor; in this case an oximeter which may include an oximetry probe 41 and an oximeter module 40. Probe 41 acquires data indicative of the subject's blood oxygen level (and optionally heart rate), and oximeter module 40 processes data received from probe 41 in order to provide an electrical signal which includes data indicative of the subject's blood oxygen level (and optionally data indicative of the subject's heart rate). Blood oxygen data from oximeter module 30 is provided to processor/transmitter module 60 where it may be further processed and then transmitted to display component 7 over link 64. Data acquisition component 20 also includes a power supply 25 which provides electrical power to GPS module 30, oximeter module 40, probe 41, and processor/transmitter 60, as needed. GPS antenna 80 may also receive electrical power from power supply 25 when an active GPS antenna is used.

It will be understood that the physiological monitor used in embodiments of the monitoring system of the present invention is not limited to an oximeter. The physiological monitor may alternatively comprise, for example, a heart rate monitor which may include a heart rate module and associated sensor or probe for acquiring data indicative of the subject's heart rate. The data acquired by a heart rate monitor sensor or probe is processed in the heart rate module in order to provide data indicative of the subject's heart rate to processor/ transmitter module 60 for further processing and transmittal to display component 7 over link 64.

5

Processor/transmitter module 60 may include a processor 66 which processes data received from oximeter module 40 and GPS module 30 in accordance with instructions stored in memory 67. The data is thereafter transmitted to display component 7 by a wired or wireless link 64. Thus, electronic link 64 may merely comprise one or more electrical cables or wires located between processor 66 and display component 7 (see. e.g., Fig. 19). Alternatively, data may be transmitted by a wireless link using, for example, radio waves. Thus, in the embodiment of Fig. 5, processor/transmitter module 60 includes an RF transmitter 65 which transmits data received from processor 66 via radio waves to receiver 76 of display component 7.

10

15

As mentioned above, display component 7 includes a receiver 76 for receiving data transmitted by data acquisition component 20. The received data may include, for example, data indicative of the subject's location, altitude, heading, velocity, pace, distance traveled, blood oxygen level and/or heart rate, (and optionally the current time as determined by the GPS device). This data is then provided to processor 75 wherein it may be further processed in accordance with instructions stored in memory 77. After processing, acquired and/or calculated data is displayed on display screen 52 where it is visible to the subject or an individual monitoring the subject's performance. Display component 7 may also include a power supply 78 for supplying power to

20

25

processor 75, receiver 76, and other components, as necessary, within display component 7.

5 It should be noted that transmitter 65 and receiver 76 may alternatively each comprise transceivers so that electrical signals may be transmitted in both directions (i.e., from data acquisition component 20 to display component 7, and from display component 7 to data acquisition component 20).

10 Display component 7 may also include one or more alarms 79, each of which provides an audible and/or visual alarm in response to a signal received from processor 75. A plurality of input devices may also be provided on display component 7 so that the subject or other individual may control the processing and/or display of acquired data on display screen 52. Such input devices may comprise, for example, input switches 53–56. Display component 7 may further include a peripheral interface 85 which allows display component 7 to be linked to an external device such that data may be transmitted from display component 15 7 to the external device (such as a PC, as described previously). In this manner, data concerning the subject's performance of a physical activity may be stored for further processing, analysis and/or retrieval. Peripheral interface 85 may be configured in a variety of manners, depending upon the type of connection to the external device (such as a PC). For example, data may be transmitted from 20 display component 7 to a PC over a wired link. Thus, peripheral interface 85 may merely comprise an electrical terminal to which one end of a cable may be attached. The other end of the cable may then be attached to the PC, such as through a USB port or a serial port. Alternatively, display component 7 may transmit data by means of a wireless link, such as by radio waves or infrared. 25 Thus, peripheral interface 85 may also include a transmitter capable of transmitting radio waves or an infrared signal to a PC which is configured to receive radio waves or an infrared signal. A variety of other structures well-known to those skilled in the art may also be used for peripheral interface 85 in order to transmit data to a PC or other external device.

Electronic Positioning Device

As mentioned above, one embodiment of the monitoring system of the present invention includes an electronic positioning device which determines the subject's location, altitude, heading, velocity, pace, and/or distance traveled based upon electromagnetic signals received from three or more sources. While other positioning devices may be employed, one embodiment of the monitoring system of the present invention employs a GPS device. In general, the GPS device receives electromagnetic signals from three or more satellites, and computes the user's location based upon those signals. In essence, each satellite signal provides the three-dimensional location of the satellite at a precise time. The GPS device then computes the time it took for each signal to reach the GPS device, and this data is then used to compute the user's precise location (typically in terms of the user's longitude and latitude at the time of receiving the GPS satellite signals, and optionally the user's altitude).

The GPS device may generally include an antenna (an active or passive antenna) and a GPS processing module, as previously described. The antenna receives GPS signals from three or more orbiting satellites and transmits the acquired data to the GPS processing module. Thus, as shown in Fig. 5 which is a schematic illustration of one embodiment of the present invention, GPS antenna 80 is in electrical communication with GPS processing module 30, and therefore transmits data acquired from three or more GPS satellites to GPS module 30. It should be noted that while GPS antenna 80 and GPS module 30 are depicted as separate units, they may alternatively be combined into a single structure. GPS processing module 30 then computes the precise location of the subject, and may provide an electrical signal indicative of this position (e.g., in terms of latitude, longitude, and altitude) to processor/transmitter module 60 for further processing.

While GPS processing module 30 may merely transmit raw data indicative of the subject's position to processor/transmitter module 60, GPS module 30 may alternatively process the location data in order to compute, and provide an electrical signal indicative of the subject's velocity, heading, pace and/or distance traveled, as well as the current time. The computed data may then be transmitted to module 60 for further processing and transmittal to display component 7. Of course, it will be understood that, depending upon the level of processing provided by GPS module 30, processor/transmitter module 60 may simply receive data from GPS module 30 and pass the data substantially unaltered to display component 7 via link 64. Thereafter, the transmitted data may be further processed within display component 7, as needed, so as to provide additional data such as average velocity, average pace, workload (based on the subject's weight) and/or other useful information as desired.

in order to compute the distance traveled, a "start point" must be provided to the monitoring system. If the distance traveled is computed by GPS module 30 or processor 66 of processor/ transmitter module 60, the subject's location when data acquisition component 20 is first powered up may be selected as the start point for purposes of calculating the distance traveled. Alternatively, an input device may be provided on data acquisition component 20 in order to commence calculation of the subject's distance traveled. If transmitter 65 of processor/transmitter module 60 is replaced by a transceiver, data acquisition component 20 may also receive a start point signal from display component 7. In this manner, the subject may input a start point (such as by pressing a start button or switch) provided on display component 7 in order to commence calculation of the subject's distance traveled. As yet another alternative, the subject's distance traveled may be computed in processor 75 provided in display component 7, thus alleviating the need to provide a start point signal to data acquisition component 20.

In order to provide the above-described functionality, the GPS device utilized in embodiments of the present invention may employ conventional, commercially-available components. As described in U.S. Patent No. 5,627,548 which is incorporated herein by way of reference, an integrated circuit (IC) may be used in GPS module 30, wherein the IC includes, for example, a low-noise amplifier for boosting signals received from the GPS antenna, a downconverter for translating the amplified signals to a more suitable frequency, and one or more processors (such as a code-processor and a navigation processor). Numerous manufacturers provide both GPS antennas, as well as GPS "receivers", the latter of which may be incorporated into GPS module 30 of the present invention. Commercially-available GPS receivers generally comprise a circuit board having thereon one or more microprocessor units, one or more custom integrated circuits, software, and other electronic componentry necessary for performing GPS functions. The GPS antenna (also commercially-available) is merely operatively connected to the GPS module (such as by way of a coaxial cable, or other wired or wireless link). A power supply is also operatively connected to the GPS module. The GPS module will then provide (such as through a suitable electronic connector) an electrical signal which includes data indicative of, for example, the subject's latitude, longitude, altitude, velocity and/or heading, as well the current time (the latter based upon the received satellite signals). Therefore, GPS module 30 may simply comprise a commercially-available GPS receiver, along with suitable connection elements which allow GPS antenna 80, power supply 25, and processor/transmitter module 60 to be operatively connected to the GPS receiver portion of GPS module 30.

One commercially-available GPS receiver which may be used in an embodiment of the present invention is the GPS-PS1 receiver available from μ -blox AG, of Zurich, Switzerland. Alternatively, the GPS-MS1 receiver (also available from μ -blox AG) may be used. Suitable GPS antennas are also available from μ -blox AG, as well as other sources.

While some commercially-available GPS systems simply display the user's location (typically in terms of longitude and latitude values, and optionally altitude), as mentioned previously, an embodiment of the present invention utilizes GPS location data for computing velocity, pace and/or distance traveled.

5 Thus, the GPS device used in embodiments of the present invention may acquire location information at predetermined intervals, such as between about 0.1 and about 1.0 seconds. In this manner, the GPS device is capable of periodically determining the subject's location (e.g., determining the subject's location between about every tenth of a second and about every second). Such

10 periodic location data can then be further processed (such as in the GPS module, or alternatively in processor/transmitter module 60, or even in processor 75 of display component 7) in order to compute the subject's velocity (e.g., speed in miles per hour), pace (e.g., the user's speed in terms of the number of minutes to complete one mile), or distance traveled (e.g., the distance that the user has traveled since an initial start point). The commercially-available GPS receivers mentioned above are generally configured for computing velocity, and may be readily programmed to compute pace and/or distance traveled. In this manner, these commercially-available GPS receivers may be incorporated into GPS module 30 such that GPS module 30 will provide a signal which includes

15 data indicative of the subject's latitude, longitude, altitude, velocity, heading, pace and/or distance traveled (as well as the current time).

20

An embodiment of the monitoring system of the present invention which includes an electronic positioning device is useful even without the inclusion of a physiological monitor. For example, an individual can use the GPS device of the monitoring system while running (or performing any other physical activity) in order to determine their velocity at any given moment (e.g., in miles per hour), their pace at any given moment (e.g., in terms of minutes per mile), and/or the total distance they have run since an initial start time (e.g., from the moment they begin running).

25

When the monitoring system includes both an electronic positioning device (such as a GPS device) and a physiological monitor (such as an oximeter or heart rate monitor), data provided by the GPS system may be used in conjunction with the physiological data for performance monitoring, testing and/or training. By way of example, a heart rate monitor device incorporated into a monitoring system according to the present invention may display a subject's heart rate at any given moment, while a GPS device of the system simultaneously displays the subject's velocity and/or pace. In this manner, the subject (or another individual such as a coach or trainer) can more effectively monitor the subject's performance, exertion level and/or progress. By itself, a runner's velocity (or pace) is a poor indicator of performance and/or progress (i.e., improvement). Likewise, heart rate alone is a poor indicator of performance and/or progress when the subject's velocity (or pace) is not known. Simultaneously monitoring velocity (or pace) and heart rate (and/or blood oxygen level), however, provides the missing link; i.e., the physiological effect of running at a certain speed. Thus, incorporating an electronic positioning device and a physiological monitor into an integrated system provides more meaningful data.

Oximeter

As blood is pumped through the lungs, deoxyhemoglobin in the bloodstream absorbs oxygen to become oxyhemoglobin. Thereafter, the oxygenated blood is delivered throughout the body, where the oxygen is released in order to support metabolic function. Medical personnel often monitor a patient's blood oxygen level as one indicator of the patient's overall condition. For example, a patient's blood oxygen level is typically monitored during surgery in order to ensure that sufficient oxygen is reaching the patient's brain and other vital organs.

5

Blood oxygen levels are typically monitored in terms of the oxygen saturation level, which is defined as the amount of oxyhemoglobin as a percentage of the total hemoglobin. For example, the typical oxygen saturation level of a healthy adult at rest is between about 96% and about 98%, which simply means that between about 96% and about 98% of the hemoglobin in the arterial blood is oxygenated (i.e., converted to oxyhemoglobin). As used herein, the term oximeter includes any device capable of determining blood oxygen level.

10

Many commercially-available oximeters employ light absorption measurements to determine blood oxygen levels, as well as heart rate. When light is directed towards a volume of blood (such blood in an artery), a portion of the light is absorbed by surrounding tissue as well as the blood. A sensor may then detect the amount of light which is transmitted through or reflected by the blood and surrounding tissue (i.e., light which is not absorbed by the blood or surrounding tissue). During systole, the volume of blood in the artery is increased, and more light will be absorbed by the blood. During diastole, the volume of blood in the artery decreases, and in turn the amount of light absorption decreases. Since light absorption by the surrounding tissue remains constant, the amount of light absorption will vary as a function of heart rate. Therefore, the subject's heart rate can be readily determined simply by monitoring the amount of light absorption (e.g., by measuring the length of time between peak levels of light absorption).

15

20

25

Oxyhemoglobin and deoxyhemoglobin differ in their absorption of light, and these differences in light absorption properties can be employed to determine the blood oxygen level. By measuring light absorption at two or more different wavelengths, blood oxygen level can be readily determined. For example, deoxyhemoglobin absorbs more red light than does oxyhemoglobin, while oxyhemoglobin absorbs more infrared light than deoxyhemoglobin. Since the absorption properties of oxyhemoglobin and deoxyhemoglobin are well-

known, the ratio of oxyhemoglobin to total hemoglobin can be readily determined merely by measuring light absorption at a red wavelength and at an infrared wavelength. The ratio of light absorption at the two frequencies (e.g., red light absorption divided by infrared light absorption) can be compared to values in a look-up table in order to provide a measurement of blood oxygen level.

5

Typically, an oximeter directs light of two different predetermined wavelengths in alternating fashion towards a volume of blood, and a light sensor detects light which is transmitted through or reflected by the blood. Data acquired by the light sensor is then processed in order to provide a measure of the oxygen level of the blood. In the embodiment depicted schematically in Fig. 10 5, a probe 41 may include a pair of light sources for directing light of two different wavelengths at a volume of blood, as well as a light sensor for detecting light which is transmitted through or reflected by the blood. By way of example, the light sources (such as LED's) may be configured to emit red light 15 (e.g., a wavelength of between about 610 nm and about 650 nm) and infrared light (e.g., a wavelength of between about 810 nm and about 850 nm). Probe 41 is in electronic communication with oximeter module 40 via a wired or wireless connection, such that probe 41 transmits data indicative of detected light to module 40. Oximeter module 40 includes a processor and other 20 electronic componentry which provides an electrical signal indicative of the subject's blood oxygen level, and optionally the subject's heart rate. Oximeter module 40 is in electrical communication with processor/transmitter module 60, such that the electrical signal indicative of the subject's blood oxygen level (and optionally heart rate) is transmitted to processor 66. After processing, 25 processor/transmitter module 60 may transmit the resulting oximetry data to display component 7, as previously described. Alternatively, the oximetry data from oximeter module 40 may be merely transmitted to display component 7 by processor/transmitter module 60.

The oximeter device utilized in embodiments of the present invention may employ commercially-available components in order to provide the functionality described above. For example, numerous manufacturers provide both oximeter probes, as well as oximeter modules which may be used in the present invention. Commercially-available oximeter modules are provided, for example, as integrated circuits which may include one or more microprocessors, software, and other electronic componentry for generating an electrical signal which includes data indicative of the subject's blood oxygen level and heart rate. The oximeter probe (also commercially-available) is merely operatively connected to the oximeter module (such as by way of a wired or wireless connection), and the oximeter module will then provide an electrical signal which includes data indicative of the subject's blood oxygen level and heart rate. A commercially-available oximeter module may be repackaged into an enclosed unit suitable for attachment to a support member (such as a belt to be worn by the subject) in electrical communication with the other elements of data acquisition component 20. One commercially-available oximeter module which may be used in an embodiment of the present invention is the OEM2 Pulse Oximeter Module available from Nonin Medical, Inc. of Plymouth, Minnesota. Suitable oximeter probes are also available from Nonin Medical, Inc., as well as other sources.

It should be noted that the monitoring systems of the present invention preferably determine, and the analytical and training methods preferably utilize, the subject's systemic blood oxygen level, rather than localized oxygen levels (such as in or near active muscle tissue). When a subject performs a physical activity, particularly a strenuous activity, blood oxygen level within and around working muscles may vary considerably from the subject's systemic blood oxygen level (i.e., the level of oxygen in the bloodstream as a whole). Thus, the monitoring systems according to the present invention are preferably configured in order to minimize any localized variance in blood oxygen levels as compared to the subject's systemic blood oxygen level. This may be accomplished, for

example, by positioning the oximetry probe in a location of minimal muscle activity, thereby avoiding active muscle tissues or regions.

Heart Rate Monitor

5 As mentioned previously, the physiological monitor used in certain
embodiments of the present invention may comprise a heart rate monitoring
device which provides data indicative of the subject's heart rate. By way of
example, oximeter module 40 in Fig. 5 may merely be replaced by a heart rate
module which processes data received from probe 41 in order to provide an
electrical signal which includes data indicative of the subject's heart rate. In fact,
10 a heart rate module similar in configuration to oximeter module 40 may be
employed, except that the electronic componentry need not be configured for
determining the subject's blood oxygen level. In addition, probe 41 may be used
with a heart rate module, since, as described previously, the light absorption of
blood will vary with the subject's heart rate. During systole, the volume of blood
15 in an artery increases, thereby resulting in a detectable increase in light
absorption. Thus, the subject's heart rate may be readily determined, for
example, by measuring the period of time between light absorption peaks (i.e.,
peaks corresponding to systole). It should be pointed out, however, that light of
a single wave length is sufficient for monitoring the subject's heart rate.
20 Therefore, only a single light source is required in probe 41 if oximeter module
40 is replaced by a heart rate module.

As an alternative to employing light absorption measurements for
determining heart rate, electrocardiography ("ECG") may be employed. A
beating heart produces electrical pulses which can be readily measured in a
variety of manners well-known to those skilled in the art. For example, a pair or
25 electrodes may be positioned against the subject's chest in the region
surrounding the heart, such that the electrodes will detect ECG signals. Thus,
probe 41 may be replaced by an ECG-type probe having a pair of electrodes

suitable for detecting ECG signals and transmitting data indicative of the subject's heart rate to a heart rate module. By way of example, U.S. Patent No. 5,491,474, which is incorporated herein by way of reference, discloses a telemetric transmitter unit which may be used as a heart rate sensor or probe in
5 embodiments of the present invention. The telemetric transmitter unit of this patent is configured to be worn about the subject's chest such that the electrodes of the transmitter unit are operatively positioned so as to detect ECG signals. As described in U.S. Patent No. 5,840,039, which is also incorporated
10 herein by way of reference, data indicative of the subject's heart rate may be transmitted by the telemetric transmitter unit to a telemetric receiver unit. In the present invention, the telemetric receiver unit may simply comprise the heart rate module provided by data acquisition units 20. Alternatively, data from the telemetric transmitter unit may be transmitted directly to data display component
15 7 of the present invention, such as by the methods of U.S. Patent No. 5,840,039. The transmitted heart rate data may then be further processed by data display component 7, as desired. Of course, it is also contemplated that instead of the wireless data transmission described in U.S. Patent No. 5,840,039, the heart rate probe or sensor (such as the telemetric transmitter unit described previously) may be in electrical communication with either data acquisition
20 component 20 or data display component 7 by means of one or more wires.

Data Display Component

As mentioned above, display component 7 receives an electrical signal from data acquisition component 20 via a wired or wireless link 64 (see Fig. 5). This electrical signal will generally include data indicative of one or more of the
25 following: location, altitude, velocity, pace, distance traveled, heading, blood oxygen level and heart rate. The electrical signal may be received, for example, by receiver 76 (which may alternatively comprise a transceiver). The received electrical signal is then provided to processor 75 where the data may be further processed in accordance with instructions stored in memory 77. The acquired
30 data may be processed in processor 75 in a variety of manners, depending

upon, for example, the type of data which the subject or other individual wishes to monitor. After processing, the data may then be displayed on display screen 52. The subject, or other individual monitoring the subject's performance, may even select the type of data to be displayed by, for example, employing switches 53-56. By way of example, the subject may select one or more predetermined formats for data display utilizing input switches 53-56.

Data display component 7 may also include one or more alarms 79 which provide an audible and/or visible indication to the subject or other individual monitoring the subject's performance. Data display component 7 may be programmed such that an alarm 79 will be activated if a data value departs from a predetermined limit or range. For example, the monitoring system of the present invention may be programmed such that an alarm 79 will be activated if the subject's velocity, pace, distance traveled, blood oxygen level or heart rate is outside a predetermined range. In one embodiment, the subject may program the monitoring system of the present invention, such as by using input switches 53-56, in order to set predetermined levels or ranges for a variety of acquired data. For example, the subject can input an alarm level or range for blood oxygen level, such that an alarm 79 will be activated if the subject's blood oxygen level falls below the predetermined level or outside of the predetermined range. Similar alarm set points can be established by the subject or another individual monitoring the subject's performance for velocity, pace, distance traveled and/or heart rate. In this manner, the subject's performance of the physical activity can be precisely controlled. It should be pointed out that alarms 79 may take a variety of configurations, such as a device capable of generating an audible sound (such as a tone or beep) in response to a signal received from processor 75, or a device capable of generating a visible signal (e.g., a blinking light source) in response to a signal received from processor 75.

As further discussed below, data display component 7 may also include one or more status indicators 57 and 58 (see Fig. 10). Status indicators 57 and

58 may be operatively connected to processor 75 such that one of said status indicators is activated when data acquisition component 20 is not operating properly. For example, the status indicators may merely comprise a portion of display screen 52 which illuminates in order to alert the subject or other individual monitoring the subject's performance that, for example, the GPS device has not acquired the necessary satellite signals, or the physiological monitor is not properly acquiring physiological data from the subject.

Exemplary Embodiment of Exercise Monitoring System

As mentioned previously, Fig. 3 depicts a runner using an exemplary exercise monitoring system according to one embodiment of the present invention. In the monitoring system of Fig. 3, data acquisition component 20 is configured to be worn about the waist of the subject. As more fully described herein, the data acquisition component can comprise any of a variety of structures and configurations, and the structure shown in Fig. 3 is merely exemplary of one embodiment of the present invention. The data display component in Fig. 3 comprises a data display component 7 worn about the wrist of the subject. Once again, as more fully described herein, the data display component can comprise any of a variety of structures and configurations, and that shown in Fig. 3 is merely exemplary of one embodiment.

Data acquisition component 20 acquires data while a subject wearing component 20 performs a physical activity. The acquired data is processed and then displayed by data display component 7. In this manner, data may be acquired while the subject performs the physical activity at any location, thus allowing performance testing and monitoring to be performed anywhere. As shown in the perspective view of Fig. 4, data acquisition component 20 includes a support member 15 which generally comprises an elongate member sized and configured to be worn about the user's waist. Support member 15 may be made

from any of a variety of suitable materials, particularly flexible materials such as polyurethane or other plastics which can be manufactured to be both flexible and soft. Support member 15 may include connector elements at each end thereof in order to facilitate securing support member 15 about the user's waist. These
5 connector elements may comprise any conventional elements used to secure a belt about a person's waist, including conventional belt buckle elements, or hook and loop fastener elements. In the embodiment shown, male and female connector elements 21 and 22, respectively, are provided at opposite ends of support member 15. Connector elements 21 and 22 are made from a resilient
10 plastic, thereby allowing male element 21 to be releasably snapped into female element 22 in order to secure support member 15 about the user's waist. Support member 15 may also be adjustable in length to accommodate different waist sizes, and to allow support member 15 to be adjusted for comfort.

As best seen in the enlarged view of Fig. 6, the various modules
15 described previously are mounted on support member 15 in order to provide the desired data acquisition functions. The modules are preferably provided on support member 15 at a side opposite to connector elements 21 and 22 (as shown in Fig. 4). In this manner, support member 15 may be worn about a subject's waist, with connector elements 21 and 22 located in front, with the
20 modules positioned adjacent the subject's lower back. Not only does this arrangement provide for ease of use (i.e., connecting and disconnecting connector elements 21 and 22), it also provides a more comfortable arrangement due to the increased bulk of the modules. In addition, when a probe or sensor (such as an oximeter probe) is incorporated into support
25 member 15, the probe or sensor may be operatively positioned against the subject's lower back. Of course other arrangements may be provided, particularly whenever it is necessary to orient a probe or sensor at some other location with respect to the subject's body.

5 GPS module 30, oximetry module 40, antenna 80 and processor/
transmitter module 60 may be provided on support member 15. Each may be
removably attached to support member 15 such that they may removed and
attached as needed, or even replaced by other modules which provide different
functionality (such as a heart rate monitor module). Each module generally
includes electronic circuitry suitable for performing the desired data acquisition
and/or processing function, as described above (e.g., acquiring data indicative
of blood oxygen level of a subject wearing support member 15).

10 While each module may include the necessary circuitry for independently
acquiring, processing and transmitting data, the embodiment of data acquisition
component 20 depicted in Fig. 4 includes circuitry which allows data and other
electrical signals to be passed from one module to another. In this manner, for
example, a single processor/transmitter module 60 may be employed for not only
processing data from GPS module 30 and oximeter module 40, but also for
15 transmitting such data to display component 7. In addition, one or more power
supplies, such as batteries 125, may provide power to multiple modules
provided on support member 15. In order to provide such electrical integration
of data acquisition component 20 and the various modules attached thereto,
support member 15 may include a plurality of electrical conduits to allow
20 electrical signals to be exchanged between the various modules, as desired.
Each of the modules (including antenna 80) is configured such that each may
be attached to belt 20 in electrical communication with one or more of the
electrical conduits of belt 20.

25 Electrical conduits may be provided on support member 15 in a variety
of manners, such as along inner surface 24 or outer surface 23 of support
member 15. Alternatively, a plurality of electrical conduits may be provided
within the interior of support member 15. As best seen in the cross-sectional
view of Fig. 12, a plurality of electrical conduits 63 extend through the interior of
support member 15, and are thus protected and insulated by the material from

which support member 15 is formed. Individual conduits may be provided within support member 15 (as shown in Fig. 12), or a flexible electrical strip such as a membrane circuit may be provided within support member 15. One or more separate conduits for transmitting electrical power may also be provided in support member 15. Thus, as seen in Fig. 12, first and second power cables 61 and 62, respectively, extend through the interior of support member 15. Electrical conduits 63 and power cables 61 and 62 may extend through the interior of support member 15 in any of a variety of patterns; generally as necessary to provide the desired electrical connections between the various modules and power supplies. Of course, it will be understood that conduits for transmitting electrical power from batteries 25 to the various modules may also be provided on a flexible electrical strip along with the electrical conduits described previously.

The various modules and support member 15 are configured such that each module may be attached to support member 15 in electrical communication with one or more of electrical conduits 63, and optionally one or both of power cables 61 and 62. As best seen in the top plan view of Fig. 7, wherein the modules have been removed from support member 15, a plurality of electrical apertures 29 (also commonly referred to as female connectors or female electrical terminals) are provided on support member 15. Electrical apertures 29 may be arranged in any desired pattern, and the rectangular grid shown is merely exemplary of one possible arrangement. The arrangement of electrical apertures 29, however, should correspond with the arrangement of electrical connectors provided on each module (as described below). Each aperture 29 is in electrical communication with one of electrical conduits 63. A pair of power apertures 28 are also provided above and below each grid of electrical apertures 28, and each power apertures is in electrical communication with one of first and second power cables 61 and 62.

Turning to Fig. 8 which depicts GPS module 30, a plurality of electrical connectors 33 (also commonly referred to as male connectors or male electrical terminals) extend away from rear surface 34 of GPS module 30. Electrical connectors 33 may be arranged in the same pattern as electrical apertures 29 on support member 15. Similarly, GPS module 30 includes a pair of power connectors 32 which extend away from rear surface 34 of module 30, above and below the grid of electrical connectors 33. In this manner, GPS module 30 may be attached to support member 15, with each electrical connector 33 engaging an electrical aperture 29 on support member 15 and each power connector 32 engaging a power aperture 28 on support member 15. Thus, the arrangement of electrical connectors 33 and power connectors 32 on GPS module 30 should correspond to an arrangement of electrical apertures 29 and power apertures 28 on support member 15. In the embodiment of Fig. 7, each rectangular grid of electrical apertures 28 and corresponding pair of power apertures 28 (i.e., above and below the rectangular grid) are identical. Thus, GPS module 30 can be attached to support member 15 at a variety of locations. The other modules may have an arrangement of electrical connectors 33 and power connectors 32 which is similar to that for GPS module 30 (as shown in Fig. 8). In this manner, each module can be attached to support member 15 at a variety of locations. Alternatively, each module may have a unique configuration which allows that module to be attached to support member 15 only at one or more selected locations.

In order to further secure GPS module 30 to support member 15, a pair of mounting tabs 31 may also extend away from rear surface 34 of module 30. A pair of corresponding mounting apertures 27 are provided on support member 15. Mounting tabs 31 and mounting apertures 27 are arranged such that GPS module 30 may be attached to support member 15 with each mounting tab 31 engaging a mounting aperture 27 on support member 15. Each mounting tab 31 may be resilient in nature such that the end portion of the mounting tab will engage a mounting aperture, thereby securely attaching GPS module 30 to

support member 15. The other modules may each include similar mounting tabs such each module may be securely attached to support member 15 in the same manner. In fact, each module may have a shape and configuration similar (or even identical to) GPS module 30. Of course a variety of alternate configurations may be employed for each module, particularly if the system is designed such that each module can be attached to support member 15 only at a single, predetermined location. It should be pointed out that processor/transmitter module 60 of the embodiment shown in Fig. 4 is sized somewhat larger than GPS module 30 and oximeter module 40. Thus, module 60 may include four mounting tabs 31 for attachment to support member 15 at region P shown in Fig. 7.

While individual power supplies may be provided in each module, one or more power supplies may be provided on support member 15 in order to provide electrical power to each module. A variety of sources of electrical power may be provided, such as rechargeable or non-rechargeable batteries, one or more solar cells, or a combination of any of the foregoing power sources. In the embodiment shown in Fig. 4, a pair of batteries 125 are provided on support member 15 in electrical communication with first and second power cables 61 and 62. Each battery 125 may be removably or permanently secured to support member 15, and may be located internally or externally of support member 15. Each battery 125 may provide power to selected modules, or both batteries may be configured to provide power to all of the modules. A power switch 26 may also be provided on support member 15. Power switch 26 is operable for turning support member 15 on and off (i.e., allowing power to be supplied to the modules when switch 26 is in its on position).

Fig. 15 depicts an alternative data acquisition component according to an embodiment of the present invention. In the embodiment of Fig. 15, the data acquisition component is configured similar to a bra, and therefore includes a fabric article 114 configured to be worn about a subject's chest. A support

member 115 is incorporated into the fabric article. In fact, support member 115 may be configured identical to support member 15 described above, and includes the various modules and other components described in conjunction with the data acquisition component of Fig. 4. Support member 115 may be secured to fabric article 114 in a variety of manners, such as an adhesive or by sewing support member 115 directly to fabric article 114. An opening may also be provided in fabric article 114 in the region of the oximeter probe in order to allow the probe to be urged against the subject's back, such as below the subject's shoulder blade. Of course it will be recognized that support member 115 may be used without fabric article 114, such that support member 115 is merely secured about the subject's chest similar to the manner in which the telemetric transmitter unit of a conventional heart rate monitor is secured about a user's chest.

As best seen in Fig's 11 and 12, probe 41 is integrally provided on support member 15 such that probe 41 extends partially away from inner surface 24 of support member 15. In this manner, support member 15 will urge probe 41 against the subject's skin in the lower back region in order to acquire blood oxygen data. An electrical connector 45 (such as a cable or wire) electrically connects probe 41 to the oximeter module. Probe 41 includes a first light source 42 configured for emitting red visible light, and a second light source 43 configured for emitting infrared light. First and second light sources 42 and 43 may comprise, for example, LED's. Probe 41 also includes a light sensor 44. Thus, probe 41 may acquire blood oxygen and heart rate data in the manner described previously.

Figure 18 depicts an alternative embodiment of a physiological monitor for use with the data acquisition component of the monitoring system of the present invention. In the embodiment of Fig. 18, probe 141 is remote from the support member for the data acquisition component of the monitoring system. Thus, probe 141 is operatively connected to oximeter module 130 by means of

a cable 145. Of course another suitable wired or wireless link may be used in place of cable 145. The configuration of Fig. 18 is advantageous in that probe 141 may be attached to the subject in a variety of locations, such as the subject's lower back, torso, beneath the shoulder blade, or even on the subject's head (such as on the subject's forehead). Therefore, probe 141 may be positioned in a variety of locations. The embodiment of Fig. 18 is also advantageous when the monitoring system is used on a non-human subject such as a horse. Probe 141 may be attached to the horse's forehead (such as using adhesive or a suitable harness), while a jockey or trainer riding the horse wears data acquisition component 20 (such as around their waist).

5
10

Display Component

As discussed previously, particularly in conjunction with the description of the schematic illustration of Fig. 5, the monitoring system of the present invention includes a display component (or display unit) for displaying data which has been acquired and processed by the data acquisition component. The display component of the monitoring system of the present invention may comprise any of a variety of structures suitable for displaying data and other information to the subject or an individual monitoring the subject's physical activity (such as a trainer or a coach). The display component may therefore comprise a personal computer having a monitor associated therewith, wherein the personal computer receives data from the data acquisition component via a wired or wireless connection. Alternatively, the display component may comprise a display device which is configured for use in a particular physical activity, such as a display unit which attaches to a bicycle in a location visible to the rider (e.g. a handlebar-mounted display unit).

15
20
25

The display component may alternatively comprise a "heads-up" type display unit configured for displaying data and other information directly to the subject. As used herein, the term "heads-up display unit" refers to any display

device which is configured to display data to the subject in front of the subject's face. Such a device may be configured to project data and other information onto glasses worn by the subject, swimming goggles, a visor worn by the subject (such as a visor attached to a bicycle helmet), or even onto a display screen which is physically attached to helmet, visor, hat or other structure positioned on the subject's head in a position so that data and other information displayed thereon is directly visible to the subject. Figure 19 depicts an exemplary heads-up display unit 107 comprising glasses of the type described in patent application number WO 99/23524 (which is incorporated herein by way of reference). Such glasses include a display assembly 153 which displays data onto eyeglass lens 152. A cable (or wire) 154 connects the glasses to processor/transmitter module 60, through peripheral interface 68 provided on module 60. Such a display device is available from the MicroOptical Corporation of Boston, Massachusetts. Alternatively, the display device described in patent application number WO 99/23525 (which is incorporated herein by way of reference) may be used. The display device described in this latter patent application essentially provides a display screen positioned in front of the subject's eyeglasses (or is otherwise positioned in front of the subject's face) so that the subject may view data and other information provided on the display screen while still being able to see through the glasses. The focal point of the display screen, however, may be adjusted so as to appear several feet in front of the subject's glasses. In this manner, the subject may view the data and other information provided on the display screen, while still being able to use the glasses in a normal fashion. Other suitable heads-up type display devices are well-known to those skilled in the art, and may be utilized in the monitoring system of the present invention.

Figures 9 and 10 depict yet an exemplary display component 7 according to one embodiment of the present invention. Display component 7 comprises a wrist watch-type display unit which may be worn about the subject's wrist. Display unit 7 includes a flexible band 51 by which the display component may

be secured about a subject's wrist. Display component 7 also includes a display screen 52, which may be configured similar to the display screen of a digital wrist watch. Thus, display screen 52 is configured so as to display data and other information to the subject by means of an LCD screen, or other suitable means well-known to those skilled in the art. Display component 7 further includes actuators or switches 53–56 which allow the subject to operate and control the monitoring system of the present invention. Display screen 52 also may be subdivided into a number of regions which are configured to display specific information to the subject. For example, first display region 70 may be configured as a three digit display which provides the subject's blood oxygen level (as a percentage of saturation) or the subject's heart rate (in beats per minute). Second display region 71 is similarly configured as a three digit display, which may be used to display the subject's velocity (in miles per hour or kilometers per hour) or the subject's pace (e.g., in minutes per mile). A third display region 72 is also shown, and may be configured to display, for example, elapsed time.

Display screen 52 also includes first and second status indicators 57 and 58. Status indicators 57 and 58 may be configured such that status indicator 57 will illuminate when the GPS device has acquired the necessary satellite signals for measurement purposes. Second status indicator 58 may similarly illuminate when the sensor or probe for the physiological monitor (such as an oximeter or heart rate monitor) is operable and acquiring physiological data from the subject. First and second mode indicator 73 and 74 may also be provided on display screen 52. First mode indicator 73 merely indicates to the subject the current mode of operation of display component 7. During use, the subject may alter the mode of operation of display component 7 in order to alter the particular data or other information displayed on display screen 52. The subject may utilize mode switch 54 to toggle display screen 52 so as to display one or more of the following data: blood oxygen level, heart rate, elapsed time ("TM"), average speed, maximum speed, year-to-date miles or kilometers ("YTD"), or the current

time ("clock mode" or "CL"). Second mode indicator 74 merely indicates to the subject whether or not data is being displayed in terms of miles per hour, kilometers per hour, or minutes per mile.

5 In order to operate display component 7, a number of actuators or switches are provided. Thus, as mentioned above, mode switch 54 is used to toggle display screen 52 between various modes of operation. Start/stop switch 53 may be used to commence data measurement. For example, the subject may press start/stop switch 53 when they begin performing a physical activity such that the measurement of elapsed time and distance traveled will begin at that point. When the start/stop switch 53 is depressed a second time, measurement of elapsed time and distance traveled will stop, similar to the manner in which a chronograph is employed. Display component 7 also includes third and fourth actuators 55 and 56 positioned on either side of display screen 52. Actuators 55 and 56 may be used for a variety of purposes, depending upon the configuration of the monitoring system. For example, actuator 55 may be used to toggle first display region 70 between displaying blood oxygen level and heart rate. Similarly, actuator 56 may be used to toggle second display region 71 between displaying miles per hour, kilometers per hour, or minutes per mile.

20 Figures 13 and 14 depict an alternative display unit 107 which is configured to be mounted on a bicycle such that a subject riding the bicycle can view the data displayed on display unit 107. Display unit 107 includes a main housing 151 and a clamp member 160 positioned beneath main housing 151. Main housing 151 and clamp member 160 each include a semi-circular groove such that when main housing 151 and clamp member 160 are positioned as shown in Fig. 14, a circular opening is provided therebetween. This circular opening is sized and configured to accept a handlebar 185 of a bicycle. In this manner, when clamp member 160 is secured to main housing 151 (such as by means of screws 161), handlebar 185 is securely held between clamp member 160 and main housing 151 as shown.

5

10

Display unit 107 further includes a display screen 152 which may be configured in the same manner as display screen 52 of the display unit shown in Fig. 10. Display unit 107 also includes input switches 153-156, which may be configured in the same manner as input switches 53-56 on the display unit shown in Fig. 10. Thus, display unit 107 is essentially the same as display unit 7 of Fig. 10, except that the clamping mechanism described above has replaced band 51 of the display unit shown in Fig. 7. It should be noted that band 51 of display unit 7 of Fig. 10 may also be used to secure display unit 7 to the handlebars of a bicycle, particular if band 51 employs a hook and loop fastening system.

Analytical and Training Methods

15

20

While the monitoring system of the present invention may simply display the exercising subject's location (e.g., in terms of longitude and latitude), altitude, velocity, pace, heart rate (e.g., in beats per minute), distance traveled, and/or blood oxygen level (e.g., as a percentage of saturation), the monitoring system of the present invention may be configured to further process, analyze or otherwise utilize this data. In this manner, the monitoring systems of the present invention may be used to monitor, analyze and/or control a subject's performance of a physical activity at any location.

25

By way of example, runners are very interested in monitoring their velocity, pace and/or total distance run. A simple pedometer may provide a rough estimate of the total distance run, however, such devices are inaccurate and do not provide a direct measurement of velocity or pace. While treadmills typically provide an accurate measurement of velocity, pace and total distance, many runners prefer outdoor running. Running on a track or premeasured route will also provide a measure of total distance run, however, many runners do not want to be restricted to running round and round on a track or on the same

course day after day. In addition, the runner will be unable to determine their instantaneous velocity, pace or total distance traveled.

5 In order to overcome the above problems, the monitoring systems of the present invention which include a GPS device may be configured to provide more than just location information. As described previously, the location data acquired by the GPS device may be used to compute and display the subject's velocity, pace and/or distance traveled. Such information is particularly useful when the subject is performing a physical activity wherein performance may be measured in terms of speed, time and/or distance, such as walking, running, 10 swimming, wheelchairs (e.g., wheel chair racing), bicycling, skating (e.g., speed skating on any surface), skiing (e.g., cross-country skiing), or boating (e.g., rowing, sailing, kayaking, or canoeing), or climbing (e.g., rock climbing). When the system is worn by a human subject performing a physical activity, he or she may simply view the display screen at any time in order to obtain their speed, pace and/or distance traveled. Alternatively, particularly when the 15 subject is an animal such as a horse, the display screen may be viewed by another individual (such as a trainer or even a jockey) in order to monitor the animal's speed, pace and/or distance traveled.

20 A monitoring system according to one embodiment of the present invention may also be configured (e.g., programmed) to provide a visual and/or audible alarm which is responsive to data provided by the GPS device and/or a physiological monitor (when provided). In one embodiment, the system is user-programmable so that a visible and/or audible alarm is activated when at least one of the subject's speed, pace, blood oxygen level and heart rate departs from a predetermined target, and/or when the subject has traveled a predetermined 25 target distance. For example, a runner may input a predetermined pace of 6:00 per mile (a pace "set point"). Thereafter, the system alarm will activate whenever the runner's pace departs from the desired 6:00 per mile pace by more than a certain amount (e.g., $\pm 10\%$). The alarm will remain activated until

the runner's pace returns to the desired level. The runner may also input a predetermined distance. Thereafter, the system alarm will activate when the runner has traveled this predetermined distance. In this manner, the runner can precisely control their speed and/or total distance without having to run on a treadmill or track.

5

The monitoring system may also be configured such that multiple targets (or set points) may be established by a user (e.g., the subject performing the physical activity, or a coach or trainer). For example, a runner may wish to perform interval training wherein they maintain a first predetermined pace for a first predetermined period of time or distance, and thereafter maintain a second predetermined pace for a second predetermined period of time or distance. Thus, the monitoring system of the present invention may be configured to allow for the input of multiple setpoints (or targets) and multiple time or distance intervals. Thereafter, a system alarm will activate when the runner's pace departs from a specified setpoint of a particular interval, thereby allowing the runner to perform interval training at precise speeds and/or distances.

10

15

The systems of the present invention may also be configured for recording speed, pace and/or distance traveled data, and maintaining such data in memory for later retrieval and/or display. For example, the start button (or other input device) may be activated in order to commence recording of data (such as to coincide with beginning performance of the physical activity). The stop button (or other input device) may thereafter be activated upon completion of the physical activity. Speed, pace, average speed, average pace, elapsed time and/or distance traveled data may then be retrieved from memory and displayed.

20

25

When the system of the present invention includes both a GPS device and a physiological monitor, data provided by the GPS device may be used in conjunction with data provided by the physiological monitor. While heart rate

and blood oxygen data is useful, the utility of such data is greatly improved if the subject's workload is also known. Thus, embodiments of the monitoring system of the present invention which includes both a GPS device and a physiological monitor allow for the monitoring of a physiological parameter (e.g., heart rate or blood oxygen level) and workload. A user may even input their weight so that the monitoring system may compute real-time workload based upon the subject's velocity and altitude changes. In this manner, the system even accounts for elevational changes when determining (and even displaying) the subject's workload. Thus, meaningful data can be obtained even when the subject is exercising at varying altitudes (e.g., running or biking on hilly terrain).

5
10

Applicants have also found that monitoring blood oxygen levels while performing a physical activity provides data which is useful for both training and analytical purposes. For example, applicants believe that blood oxygen data provides an indicia of metabolic function, and therefore provides an effective training parameter which can replace or be used in conjunction with heart rate monitoring. As further described below, blood oxygen monitoring also allows for training and analytical techniques which are generally difficult to implement using conventional physiological monitoring such as heart rate monitoring.

15

As an individual performs a physical activity, the working muscles consume oxygen at a rate which is higher than the rate of oxygen consumption while at rest. The body compensates for the increased oxygen requirements by increasing oxygen intake and/or blood flow. Oxygen intake may be increased, for example, by increasing breathing rate and/or the volume of air inhaled in each breath, while blood flow is increased by an increase in heart rate. At low levels of physical exertion, the blood oxygen level will remain at or near the subject's normal resting level. At these low levels of exertion, energy is primarily provided by an aerobic metabolic process which consumes oxygen. Since the cardiovascular system is able to supply sufficient oxygen to meet the body's demands, blood oxygen level remains at or near the normal resting levels.

20
25

As the level of exertion is increased, however, the cardiovascular system is unable to supply sufficient oxygen to meet the demands of working muscles. Thus, the body will begin to supply a portion of the energy requirements by an anaerobic metabolic process which does not consume oxygen. However, lactic acid is a byproduct of the anaerobic process, and must be eliminated by the body in order to prevent muscle failure. When only a small portion of the subject's energy requirements are provided by the anaerobic process, the body is generally able to eliminate the lactic acid byproduct. As the level of exertion is increased, however, the anaerobic process is responsible for more and more of the body's energy requirements. Eventually, the body is unable to eliminate lactic acid at the same rate that it is being produced. At this point (often referred to as the "lactate threshold" or "LT"), lactic acid will begin to accumulate in the working muscles, eventually leading to muscle failure. If the subject continues to perform at a level of exertion above LT, it is only a matter of time until the working muscles begin to fail and the subject must stop.

Applicants have surprisingly found that blood oxygen data provides an indirect measurement of the body's metabolic functioning. For example, as the level of exertion is progressively increased, the blood oxygen level will decrease. The plot shown in Fig. 16 depicts a runner's heart rate and blood oxygen level as their workload is progressively increased. Workload can easily be computed on the basis of the subject's weight and speed (and optionally altitude changes if running on a hilly course), and the monitoring system of the present invention can readily compute and display the subject's workload. As noted from the plot Fig. 16, heart rate increases with workload, while blood oxygen level decreases. Thus, it is apparent that blood oxygen level (particularly systemic blood oxygen level) varies with the metabolic functioning of the body. In fact, Applicants' discovery that blood oxygen level provides an indicator of metabolic function is quite useful in that blood oxygen data can now be used to monitor, analyze and/or control a subject's performance of a physical activity. Thus, the present invention provides methods using blood oxygen data

to perform one or more of these functions. In fact, embodiments of the monitoring system of the present invention may be configured (e.g., programmed) to provide one or more of these functions (such as activating an alarm when the subject's blood oxygen level departs from a predetermined target level or range). It should be pointed out, however, that the methods of the present invention which utilize blood oxygen data need not be performed using the exercise monitoring systems of the present invention.

One particular method provided by the present invention is a method of controlling (i.e., regulating) a subject's physical activity by monitoring the subject's blood oxygen level, and maintaining the subject's blood oxygen level at a selected level (such as a setpoint or a range) while the subject continues to perform the physical activity. Such a method can provide an effective training tool for athletes in that they (or their coaches) can more effectively control training sessions, or even monitor their performance during a race. For example, if a marathoner knows their appropriate blood oxygen level for completing a marathon, they can monitor their blood oxygen level during the race in order to ensure that their blood oxygen level does not exceed or fall below their target level.

The subject's blood oxygen level can be maintained at a selected level by adjusting the subject's workload (e.g., slowing down, speeding up, changing gears on a bike, etc.). Similarly, the subject's level of exertion may also be modified as needed in order to maintain their blood oxygen level at the selected level. The subject's oxygen intake may even be modified in order to maintain blood oxygen at the selected level. For example, various devices are available for regulating the amount of oxygen which is inhaled by an exercising subject (such as by restricting air flow to the user's lungs). A swimmer can also regulate their oxygen intake by regulating their breathing. Thus, a swimmer can even use the monitoring systems of the present invention (particularly an embodiment having an audible alarm which activates when blood oxygen departs from the

selected level) to regulate their blood oxygen by altering breathing patterns. A subject can also control the depth or volume of their breathing (e.g., deep or shallow breathing) in order to maintain blood oxygen at the desired level. The subject's blood oxygen level can also be maintained at a plurality of selected levels for one or more predetermined intervals. Thus, interval training can be performed based upon blood oxygen data.

The subject may also perform initial testing in order to determine desirable blood oxygen levels or heart rate for subsequent training or competition. For example, the subject may perform a test routine which estimates the subject's lactate threshold (i.e., the subject's blood oxygen level or heart rate at their lactate threshold). Thereafter, the subject may perform a physical activity at a blood oxygen level which is selected on the basis of their previously determined lactate threshold ("LT"). By way of example, the subject's LT may be determined using a plot similar to that of Fig. 16. The subject performs a physical activity while their blood oxygen level is monitored. The subject's workload (e.g., speed) is then incrementally increased at predetermined intervals (e.g., increase speed by 1% every two minutes) until exhaustion (or some other selected endpoint). When blood oxygen is plotted against workload (or even speed), the subject's LT will generally correspond to the point of inflection identified at A in Fig. 16.

As yet another alternative, a fitness parameter (such as LT) of a subject may first be determined. Thereafter, the same fitness parameter may be measured on subsequent occasions in order to measure improvements in the subject's fitness.

The monitoring system of the present invention described above may even be programmed to provide for determining a fitness indicator (such as LT). The subject's weight may be inputted into the system, and the subject will then begin performing the physical activity (e.g., running). The system may

5

determine the subject's speed and altitude changes, which the system then uses to calculate the subject's workload. The system may even be programmed to signal to the subject when the workload should be increased (such as by activating an alarm). Once the test protocol has been completed, the system will calculate the subject's LT (or other fitness indicator) on the basis of the acquired workload and blood oxygen data. Alternatively, the system may use heart rate (rather than blood oxygen data) to compute the fitness indicator (such as LT) by well-known methods. One such well-known test protocol is the Conconi Test which employs heart rate measurements with increasing workload to determine a subject's VO₂max.

10

Blood oxygen data can also be monitored while a subject performs a physical activity in order to reduce variability in blood oxygen levels. By stabilizing blood oxygen levels while performing at a constant workload, the subject's performance will be improved. Thus, the monitoring system of the present invention may be configured to measure the time variability of the subject's blood oxygen level, particularly when the workload remains at a substantially constant level. The time variability may simply be calculated as the standard deviation of blood oxygen over a predetermined time interval (e.g., the standard deviation of blood oxygen level over the preceding 5 seconds). The manner in which the physical activity is performed may then be adjusted in order to reduce the time variability of blood oxygen level. In fact, the system may even be configured to activate an alarm if the time variability of the subject's blood oxygen level exceeds a predetermined limit. By way of example, the subject may reduce the time variability of blood oxygen by stabilizing their breathing (e.g., concentrating on deep, rhythmic breathing), or by merely concentrating on stabilizing their workload or level of exertion.

By way of example, the plot of Fig. 17a depicts a runner's blood oxygen level as their pace (in miles per hour) is gradually increased. It will be noted that the subject's blood oxygen level shows significant variability which does not

correlate with increases in workload. In other words, the subject's blood oxygen level shows significant peaks and valleys, rather than gradually decreasing as would be expected. When blood oxygen level drops and rises rapidly, the subject's performance will suffer. For example, lactate levels may begin to rise, leading to premature muscle failure. Figure 17b is a plot from the same runner, however the runner concentrated on their breathing (i.e., rhythmic, deep breathing from their belly, rather than from their chest). The result is that blood oxygen levels are more stable, even though the workload is increasing. In fact, the subject's blood oxygen level in Fig. 17b remained substantially constant at about 96% when pace was increased from about 6mph to about 9mph. In the plot of Fig. 17a, however, the subject's blood oxygen level varied between about 91% and about 98% over this same pace range. Such variability in blood oxygen level will inevitably lead to decreased performance.

Sub 1827

1. An exercise monitoring system, comprising:
(a) an electronic positioning device;
(b) a physiological monitor; and
(c) a display unit configured for displaying data provided by said electronic positioning device and said physiological monitor.

2. The exercise monitoring system of claim 1, wherein said electronic positioning device is configured to receive electromagnetic signals from three or more sources so that said monitoring system can determine at least one of a subject's location, altitude, velocity, pace, and distance traveled.

Sub 2

3. The system of claim 2, wherein said electronic positioning device comprises a GPS device.

4. The system of claim 1, wherein said physiological monitor is chosen from the group consisting of: an oximeter and a heart rate monitor.

5. The system of claim 4, wherein said electronic positioning device comprises a GPS device.

Sub 6

6. The system of claim 3, wherein said GPS device and said physiological monitor are provided as part of a user-wearable data acquisition unit which is separate from said display unit.

Sub 3

7. The system of claim 6, wherein said data acquisition unit further comprises a support member, and said GPS device and said physiological monitor are provided on said support member.

7-8

8. The system of claim 7, wherein said GPS device and said physiological monitor are removably secured to said support member.

Handwritten initials

9. The system of claim 6, wherein said data acquisition unit is configured to be worn about a human user's waist.

10. The system of claim 6, wherein said data acquisition unit is configured to be worn about a human user's chest.

¹⁰ 11. The system of claim 1, wherein said display unit is configured to be worn about a human user's wrist.

¹¹ 12. The system of claim 1, wherein said display unit is configured to be mounted to a bicycle.

13. The system of claim 1, wherein said display unit is configured to be worn about a human user's wrist.

¹² 14. The system of claim 1, wherein said physiological monitor includes a probe configured for acquiring physiological data from a user.

¹³ 15. The system of claim 4, wherein said physiological monitor comprises an oximeter.

¹⁴ 16. The system of claim 4, wherein said physiological monitor comprises a heart rate monitor.

¹⁵ 17. The system of claim 1, wherein said system further comprises an alarm which is activated when data provided by at least one of said electronic positioning device and said physiological monitor does not meet a predetermined target.

Sub 18

18. An exercise monitoring system, comprising:

- (a) an electronic positioning device configured to receive electromagnetic signals from three or more sources so that said monitoring system can determine a subject's velocity or pace;
 - (b) a display unit configured for displaying data provided by said electronic positioning device; and
 - (c) an alarm, wherein said alarm is activated when a subject's velocity or pace does not meet a predetermined target.
19. An exercise monitoring system, comprising:
- (a) an oximeter configured to determine a subject's blood oxygen level;
 - (b) a display unit configured for displaying the subject's blood oxygen level; and
 - (c) an alarm, wherein said alarm is activated when the subject's blood oxygen level does not meet a predetermined target.
20. A method of controlling a subjects physical activity, comprising:
- (a) monitoring a subject's blood oxygen level while the subject performs a physical activity; and
 - (b) maintaining said blood oxygen level at a selected level while the subject continues to perform said physical activity.
21. The method of claim 20, wherein said blood oxygen level is maintained at said selected level by adjusting the workload of said physical activity as necessary.
22. The method of claim 20, wherein said blood oxygen level is maintained at said selected level by adjusting the subject's level of exertion as necessary.

23. The method of claim 20, wherein said blood oxygen level is maintained at said selected level by adjusting the subject's oxygen intake as necessary.
24. The method of claim 20, wherein said physical activity is chosen from the group consisting of: walking, running, swimming, bicycling, skating, singing, skiing, boating, climbing, wheelchairs, snowshoeing, scuba diving, and flying.
25. The method of claim 20, wherein said step of monitoring blood oxygen level comprises:
- (a) providing an oximeter, said oximeter including a probe for non-invasively determining blood oxygen level; and
 - (b) positioning said probe on said subject at a location suitable for detecting the subject's blood oxygen level.
26. The method of claim 25, wherein said probe is positioned such that said oximeter determines the subject's systemic blood oxygen level.
27. The method of claim 25, wherein said location is chosen from the group consisting of the subject's back, head, arm, leg, chest and torso.
28. The method of claim 26, wherein said location comprises the subject's lower back.
29. The method of claim 25, wherein said probe is provided on a support member worn about the subject's waist.
30. The method of claim 20, wherein said subject is chosen from the group consisting of: humans, horses, dogs, camels, and other mammals.

31. The method of claim 20, wherein said selected level comprises a range.
32. The method of claim 20, further comprising the step of maintaining said blood oxygen level at a second selected level.
33. The method of claim 20, further comprising the steps of sequentially maintaining said blood oxygen level at multiple selected levels.
34. The method of claim 33, wherein said blood oxygen level is maintained at each selected level:
- (a) for a predetermined period of time;
 - (b) until the subject has advanced a predetermined distance; or
 - (d) until the subject has performed a predetermined amount of work.
35. The method of claim 20, wherein said selected level is chosen on the basis of blood oxygen data previously obtained while said subject performed a physical activity.
36. The method of claim 20, wherein said selected level is chosen on the basis of said subject's lactate threshold.
37. The method of claim 20, wherein said selected level is chosen on the basis of the duration of said physical activity.
38. The method of claim 20, further comprising the step of providing an alarm, said alarm configured for indicating when the subject's blood oxygen level is not at said selected level.
39. The method of claim 20, further comprising the step of providing a display unit configured for displaying the subject's blood oxygen level.

40. The method of claim 39, wherein said subject comprises a human, and said display unit is positioned so that the blood oxygen level displayed by said display unit can be viewed by said subject.
41. The method of claim 39, wherein said display unit is positioned so that the blood oxygen level displayed by said display unit can be viewed by someone other than said subject.
42. The method of claim 40, wherein said display unit is worn on the subject's wrist.
43. The method of claim 40, wherein said physical activity comprises bicycling, and said display unit is attached to the subject's bicycle so as to be visible to the subject.
44. The method of claim 40, wherein said physical activity comprises walking or running on a treadmill, and said display unit is provided on said treadmill.
45. The method of claim 20, further comprising the step of measuring at least one of the subject's velocity, pace, or distance traveled.
46. The method of claim 45, wherein said measuring step comprises: providing a GPS device operable for measuring at least one of the subject's velocity, pace or distance traveled.
47. The method of claim 45, further comprising the step of providing a display unit configured for displaying the subject's blood oxygen level, and at least one of the subject's velocity, pace or distance traveled.

48. A method of reducing a subject's blood oxygen level variability while the subject performs a physical activity, comprising:
- (a) periodically measuring a subject's blood oxygen level while said subject performs a physical activity; and
 - (b) adjusting the manner in which said physical activity is performed in order to reduce blood oxygen level variability.
49. A method of performing a physical activity, comprising:
- (a) monitoring a subject's blood oxygen level while said subject performs a physical activity; and
 - (b) indicating to said subject the time variability of the subject's blood oxygen level.
50. The method of claim 49, wherein said time variability comprises the standard deviation of the subject's blood oxygen level.
52. A method of determining a fitness indicator of a subject, comprising:
- (a) recording a subject's blood oxygen level while the subject performs a physical activity;
 - (b) varying the subject's workload while continuing to record the subject's blood oxygen level; and
 - (c) determining a fitness indicator of said subject on the basis of the recorded blood oxygen data.
53. The method of claim 52, wherein said fitness indicator comprises the subject's lactate threshold.
54. The method of claim 53, wherein said step of varying the subject's workload comprises periodically increasing the subject's workload.

55. The method of claim 52, further comprising the steps of providing a GPS device operable for measuring the subject's velocity, and determining the subject's workload using velocity measurements provided by said GPS device.

56. The method of claim 55, wherein said GPS device is further operable for measuring the subject's altitude, and wherein the subject's workload is determined using velocity and altitude measurements provided by said GPS device.

57. A method of stabilizing blood oxygen levels while exercising, comprising:
(a) monitoring the level of blood oxygen while exercising;
(b) adjusting breathing while continuing to exercise in order to stabilize the level of blood oxygen.

58. A method of comparing an individual's physical fitness to their physical fitness on a previous occasion, comprising:
(a) measuring an individual's blood oxygen level while the individual performs a physical activity at a predetermined workload; and
(b) measuring said individual's blood oxygen level on a subsequent occasion while the individual performs said physical activity.

add a³

ABSTRACT OF THE DISCLOSURE

cb17

An exercise monitoring system which includes an electronic positioning device; a physiological monitor; and a display unit configured for displaying data provided by said electronic positioning device and said physiological monitor.

0485956.05

0485956.05

Applicant: Jack B. Stubbs	
Serial No.	Attorney's Docket No.
Filed:	24278-1
For: EXERCISE MONITORING SYSTEM AND METHODS	

VERIFIED STATEMENT (DECLARATION) CLAIMING SMALL ENTITY STATUS (37 CFR 1.9(f) and 1.27(c)) - SMALL BUSINESS CONCERN

I hereby declare that I am

- the owner of the small business concern identified below:
 an official of the small business concern empowered to act on behalf of the concern identified below:

NAME OF CONCERN Paragon Solutions, LLC
ADDRESS OF CONCERN 4266 Laura Marie Drive
Waynesville, Ohio 45068

I hereby declare that the above identified small business concern qualifies as a small business concern as defined in 13 CFR 121.3-18, and reproduced in 37 CFR 1.9(d), for purposes of paying reduced fees under Section 41(a) and (b) of Title 35, United States Code, in that the number of employees of the concern, including those of its affiliates, does not exceed 500 persons. For purposes of this statement, (1) the number of employees of the business concern is the average over the previous fiscal year of the concern of the persons employed on a full-time, part-time or temporary basis during each of the pay periods of the fiscal year, and (2) concerns are affiliates of each other when either, directly or indirectly, one concern controls or has the power to control the other, or a third party or parties controls or has the power to control both.

I hereby declare that rights under contract or law have been conveyed to and remain with the small business concern identified above with regard to the invention, entitled **EXERCISE MONITORING SYSTEM AND METHODS** by inventor(s) **Jack B. Stubbs** and **Kevin L. Schwieger**.
described in:

- the specification filed herewith
 application Serial No. _____, filed _____

If the rights held by the above identified small business concern are not exclusive, each individual, concern or organization having rights to the invention is listed below* and no rights to the invention are held by any person, other than the inventor, who could not qualify as a small business concern under 37 CFR 1.9(d) or by any concern which would not qualify as a small business concern under 37 CFR 1.9(d) or a nonprofit organization under 37 CFR 1.9(e).

*NOTE: Separate verified statements are required from each named person, concern or organization having rights to the invention averring to their status as small entities. (37 CFR 1.27)

NAME _____

ADDRESS _____

INDIVIDUAL SMALL BUSINESS CONCERN NONPROFIT ORGANIZATION

I acknowledge the duty to file, in this application or patent, notification of any change in status resulting in loss of entitlement to small entity status prior to paying, or at the time of paying, the earliest of the issue fee or any maintenance fee due after the date on which status as a small entity is no longer appropriate (37 CFR 1.28(b)).

I hereby declare that all statements made herein of my own knowledge are true and that all statements made on information and belief are believed to be true; and further that these statements were made with the knowledge that willful false statements and the like so made are punishable by fine or imprisonment, or both, under Section 1001 of Title 18 of the United States Code, and that such willful false statements may jeopardize the validity of the application, any patent issuing thereon, or any patent to which this verified statement is directed.

NAME OF PERSON SIGNING Jack B. Stubbs

TITLE OF PERSON OTHER THAN OWNER CEO / TREASURER

ADDRESS OF PERSON SIGNING 4266 Laurie Marie Drive

Waynesville, Ohio 45068

SIGNATURE *Jack B. Stubbs*

DATE 11/9/99

500570



UNITED STATES PATENT AND TRADEMARK OFFICE

COMMISSIONER FOR PATENTS
 UNITED STATES PATENT AND TRADEMARK OFFICE
 WASHINGTON, D.C. 20231
 www.uspto.gov

BIBDATASHEET

CONFIRMATION NO. 6756

Bib Data Sheet

SERIAL NUMBER 09/436,515	FILING DATE 11/09/1999 RULE	CLASS 482	GROUP ART UNIT 3764	ATTORNEY DOCKET NO. 24278-1
-----------------------------	---------------------------------------	--------------	------------------------	--------------------------------

APPLICANTS

JACK B. STUBBS, Waynesville, OH, ~~NOT PROVIDED~~

KEVIN L. SCHWIEGER, Lebanon, OH, ~~NOT PROVIDED~~

KS

** CONTINUING DATA *****

** FOREIGN APPLICATIONS *****

IF REQUIRED, FOREIGN FILING LICENSE GRANTED ** SMALL ENTITY **
 ** 12/09/1999

KS

Foreign Priority claimed <input type="checkbox"/> yes <input checked="" type="checkbox"/> no	STATE OR COUNTRY OH	SHEETS DRAWING 12	TOTAL CLAIMS 57	INDEPENDENT CLAIMS 9
35 USC 119 (a-d) conditions met <input type="checkbox"/> yes <input checked="" type="checkbox"/> no <input type="checkbox"/> Met after Allowance	EXAMINER'S SIGNATURE <i>[Signature]</i>	INITIALS		
Verified and Acknowledged				

ADDRESS
 DINSMORE AND SHOHL LLP
 1900 CHEMED CENTER
 255 EAST FIFTH STREET
 CINCINNATI, OH
 45202

TITLE
 EXERCISE MONITORING SYSTEM AND METHODS

FILING FEE RECEIVED 1012	FEES: Authority has been given in Paper No. _____ to charge/credit DEPOSIT ACCOUNT No. _____ for following:	<input type="checkbox"/> All Fees <input type="checkbox"/> 1.16 Fees (Filing) <input type="checkbox"/> 1.17 Fees (Processing Ext. of time) <input type="checkbox"/> 1.18 Fees (Issue)
-----------------------------	-------------------------------------------------------------------------------------------------------------------	------------------------------------------------------------------------------------------------------------------------------------------------------------------------------------------------------

PATENT APPLICATION FEE DETERMINATION RECORD

Effective November 10, 1998

Application or Docket Number

CLAIMS AS FILED - PART I

SMALL ENTITY TYPE OR

OTHER THAN SMALL ENTITY

	(Column 1)	(Column 2)	
FOR	NUMBER FILED	NUMBER EXTRA	
BASIC FEE			
TOTAL CLAIMS	57	minus 20 = * 37	
INDEPENDENT CLAIMS	57	minus 3 = * 6	
MULTIPLE DEPENDENT CLAIM PRESENT			

RATE	FEE
	380.00
X\$ 9=	333
X39=	234
+130=	
TOTAL	947

RATE	FEE
	760.00
X\$18=	660
X78=	
+260=	
TOTAL	

* If the difference in column 1 is less than zero, enter "0" in column 2

CLAIMS AS AMENDED - PART II

SMALL ENTITY TYPE OR

OTHER THAN SMALL ENTITY

		(Column 1)		(Column 2)		(Column 3)		
AMENDMENT A		CLAIMS REMAINING AFTER AMENDMENT		HIGHEST NUMBER PREVIOUSLY PAID FOR		PRESENT EXTRA		
	Total	*	35	Minus	**	58	=	—
	Independent	*	2	Minus	***	9	=	—
FIRST PRESENTATION OF MULTIPLE DEPENDENT CLAIM								

RATE	ADDITIONAL FEE
X\$ 9=	
X39=	
+130=	
TOTAL ADDIT. FEE	

RATE	ADDITIONAL FEE
X\$18=	
X78=	
+260=	
TOTAL ADDIT. FEE	

		(Column 1)		(Column 2)		(Column 3)	
AMENDMENT B		CLAIMS REMAINING AFTER AMENDMENT		HIGHEST NUMBER PREVIOUSLY PAID FOR		PRESENT EXTRA	
	Total	*		Minus	**		=
	Independent	*		Minus	***		=
FIRST PRESENTATION OF MULTIPLE DEPENDENT CLAIM							

RATE	ADDITIONAL FEE
X\$ 9=	
X39=	
+130=	
TOTAL ADDIT. FEE	

RATE	ADDITIONAL FEE
X\$18=	
X78=	
+260=	
TOTAL ADDIT. FEE	

		(Column 1)		(Column 2)		(Column 3)	
AMENDMENT C		CLAIMS REMAINING AFTER AMENDMENT		HIGHEST NUMBER PREVIOUSLY PAID FOR		PRESENT EXTRA	
	Total	*		Minus	**		=
	Independent	*		Minus	***		=
FIRST PRESENTATION OF MULTIPLE DEPENDENT CLAIM							

RATE	ADDITIONAL FEE
X\$ 9=	
X39=	
+130=	
TOTAL ADDIT. FEE	

RATE	ADDITIONAL FEE
X\$18=	
X78=	
+260=	
TOTAL ADDIT. FEE	

* If the entry in column 1 is less than the entry in column 2, write "0" in column 3.

** If the "Highest Number Previously Paid For" IN THIS SPACE is less than 20, enter "20."

*** If the "Highest Number Previously Paid For" IN THIS SPACE is less than 3, enter "3."

The "Highest Number Previously Paid For" (Total or Independent) is the highest number found in the appropriate box in column 1.

IPR2018-00294

T4

JC625 U.S. PTO
09/436515
11/09/99

482	8
Class	Subclass
ISSUE CLASSIFICATION	

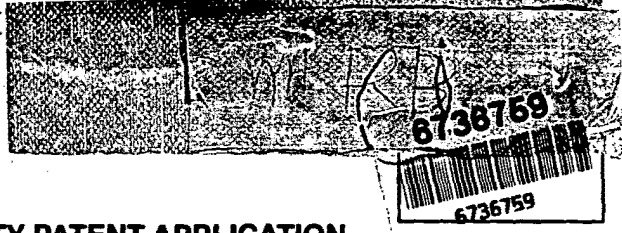

U.S. UTILITY PATENT APPLICATION

O.I.P.E. 2 PATENT DATE MAY 18 2004
 SCANNED LA O.A. KLOB

SECTOR	CLASS <u>482</u>	SUBCLASS <u>701</u>	ART UNIT <u>3661</u>	EXAMINER <u>3764 Richman</u>
--------	---------------------	------------------------	-------------------------	---------------------------------

FILED WITH: DISK (CRF) FICHE
 (Attached in pocket on right inside flap)

PREPARED AND APPROVED FOR ISSUE

ISSUING CLASSIFICATION			
ORIGINAL		CROSS REFERENCE(S)	
CLASS	SUBCLASS	CLASS	SUBCLASS (ONE SUBCLASS PER BLOCK)
<u>482</u>	<u>8</u>	<u>482</u>	<u>906 5</u>
INTERNATIONAL CLASSIFICATION			
<u>A63B</u>	<u>21/00</u>		

3/18/04 Formal Drawings (12 shts) set 11/9/99

<input type="checkbox"/> TERMINAL DISCLAIMER	DRAWINGS			CLAIMS ALLOWED	
	Sheets Drwg. <u>12</u>	Figs. Drwg. <u>20</u>	Print Fig. <u>1</u>	Total Claims <u>31</u>	Print Claim for O.G. <u>1</u>
<input type="checkbox"/> a) The term of this patent subsequent to _____ (date) has been disclaimed.	_____ (Assistant Examiner) (Date)			NOTICE OF ALLOWANCE MAILED <u>7/29/03</u>	
<input type="checkbox"/> b) The term of this patent shall not extend beyond the expiration date of U.S. Patent. No. _____	<u>Glenn E. Richman</u> PRIMARY EXAMINER (Date) <u>7/27/03</u>			Amount Due <u>1050</u>	Date Paid <u>10-30-03</u>
<input type="checkbox"/> c) The terminal _____ months of this patent have been disclaimed.	<u>D. Bruce</u> (Legal Instruments Examiner) (Date) <u>7/31/03</u>			ISSUE BATCH NUMBER	

WARNING: The information disclosed herein may be restricted. Unauthorized disclosure may be prohibited by the United States Code Title 35, Sections 122, 181 and 368. Possession outside the U.S. Patent & Trademark Office is restricted to authorized employees and contractors only.

Form PTO-438A (Rev. 6/98)

TO

ISSUE FEE IN FILE

(LABEL AREA)

(FACE)

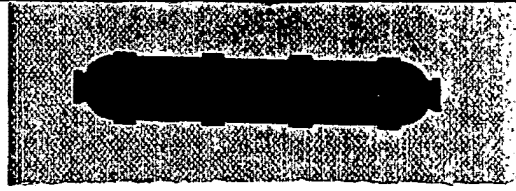

SEARCHED

Class	Sub.	Date	Exmr.
482	1-9, 900- 902	6/16/02	R
702	127,141, 142,150, 153,97	↓	↓
701	213-216, 207	↓	↓
Updated		2/9/03	R
''		7/27/03	R

**SEARCH NOTES
(INCLUDING SEARCH STRATEGY)**

	Date	Exmr.

INTERFERENCE SEARCHED

Class	Sub.	Date	Exmr.
482 701	8,900 213	7/27/03 ↓	R ↓

ISSUE SLIP STAPLE AREA (for additional cross references)

POSITION	INITIALS	ID NO.	DATE
FEE DETERMINATION	VT	69607	11/18/00
O.I.P.E. CLASSIFIER		16	11.24.99
FORMALITY REVIEW		700008	10-9-00

INDEX OF CLAIMS

- ✓ Rejected
- Allowed
- (Through numeral)... Canceled
- + Restricted
- N Non-elected
- I Interference
- A Appeal
- O Objected

Claim	Final	Original	Date
1	✓	✓	
2	✓	✓	
3	✓	✓	
4	✓	✓	
5	✓	✓	
6	✓	✓	
7	✓	✓	
8	✓	✓	
9	✓	✓	
10	✓	✓	
11	✓	✓	
12	✓	✓	
13	✓	✓	
14	✓	✓	
15	✓	✓	
16	✓	✓	
17	✓	✓	
18	✓	✓	
19	✓	✓	
20	✓	✓	
21	✓	✓	
22	✓	✓	
23	✓	✓	
24	✓	✓	
25	✓	✓	
26	✓	✓	
27	✓	✓	
28	✓	✓	
29	✓	✓	
30	✓	✓	
31	✓	✓	
32	✓	✓	
33	✓	✓	
34	✓	✓	
35	✓	✓	
36	✓	✓	
37	✓	✓	
38	✓	✓	
39	✓	✓	
40	✓	✓	
41	✓	✓	
42	✓	✓	
43	✓	✓	
44	✓	✓	
45	✓	✓	
46	✓	✓	
47	✓	✓	
48	✓	✓	
49	✓	✓	
50	✓	✓	

Claim	Final	Original	Date
51	✓	✓	
52	✓	✓	
53	✓	✓	
54	✓	✓	
55	✓	✓	
56	✓	✓	
57	✓	✓	
58	✓	✓	
59	✓	✓	
60	✓	✓	
61	✓	✓	
62	✓	✓	
63	✓	✓	
64	✓	✓	
65	✓	✓	
66	✓	✓	
67	✓	✓	
68	✓	✓	
69	✓	✓	
70	✓	✓	
71	✓	✓	
72	✓	✓	
73	✓	✓	
74	✓	✓	
75	✓	✓	
76	✓	✓	
77	✓	✓	
78	✓	✓	
79	✓	✓	
80	✓	✓	
81	✓	✓	
82	✓	✓	
83	✓	✓	
84	✓	✓	
85	✓	✓	
86	✓	✓	
87	✓	✓	
88	✓	✓	
89	✓	✓	
90	✓	✓	
91	✓	✓	
92	✓	✓	
93	✓	✓	
94	✓	✓	
95	✓	✓	
96	✓	✓	
97	✓	✓	
98	✓	✓	
99	✓	✓	
100	✓	✓	

Claim	Final	Original	Date
101			
102			
103			
104			
105			
106			
107			
108			
109			
110			
111			
112			
113			
114			
115			
116			
117			
118			
119			
120			
121			
122			
123			
124			
125			
126			
127			
128			
129			
130			
131			
132			
133			
134			
135			
136			
137			
138			
139			
140			
141			
142			
143			
144			
145			
146			
147			
148			
149			
150			

If more than 150 claims or 10 actions
staple additional sheet here

(LEFT INSIDE)

IPR2018-00293