



US005925942A

United States Patent [19]

[11] Patent Number: **5,925,942**

Theobald

[45] Date of Patent: **Jul. 20, 1999**

[54] **POWER SUPPLY CONTROL APPARATUS AND METHOD SUITABLE FOR USE IN AN ELECTRONIC DEVICE**

Theobald, "Battery Identification Apparatus and Associated Method", U.S.S.N. 08/572,837, filed Dec. 14, 1995, Atty. Docket CE01032R.

[75] Inventor: **David J. Theobald**, Woodstock, Ill.

Alberth Jr. et al., "Electronic Device Having Internal Charge Regulator and Temperature Sensor for Controlling Application of a Charging Current Thereto . . .", filed Sep. 13, 1993, U.S.S.N. 08/120,509, Atty. Docket CE00861R.

[73] Assignee: **Motorola, Inc.**, Schaumburg, Ill.

Motorola Product List Web Page, Motorola Original Adapters, Personal Cellular Phone Adapters, p. 1, 1997.

[21] Appl. No.: **08/895,390**

[22] Filed: **Jul. 16, 1997**

Motorola Product List Web Page, Motorola Original Hands Free Systems, Personal Cellular Phone Hands Free Solutions, p. 1, 1997.

[51] **Int. Cl.⁶** **H02J 7/00**

[52] **U.S. Cl.** **307/125; 307/66; 455/573; 320/137**

[58] **Field of Search** 307/125, 64, 66; 455/90, 573; 320/106, 110, 137

Motorola Product List Web Page, Motorola Original Chargers, Personal Cellular Phone Chargers, pp. 1& 2, 1997.

[56] References Cited

U.S. PATENT DOCUMENTS

4,843,299	6/1989	Hutchings	320/31
5,237,257	8/1993	Johnson et al.	320/2
5,254,931	10/1993	Martensson	320/22
5,313,661	5/1994	Malmi et al.	
5,315,228	5/1994	Hess et al.	320/31
5,333,176	7/1994	Burke et al.	455/573
5,418,445	5/1995	Alpert et al.	307/66
5,506,490	4/1996	DeMuro	320/106
5,519,303	5/1996	Goedken et al.	320/35
5,668,462	9/1997	Hansson	320/110
5,764,026	6/1998	Issa	320/137

FOREIGN PATENT DOCUMENTS

2 239 567 7/1991 United Kingdom .

OTHER PUBLICATIONS

Johnson et al., "Battery Charger Charging Time Control", U.S.S.N. 08/718,797, filed Sep. 24, 1996, Atty. Docket CEO1931R.

Primary Examiner—Albert W. Paladini
Attorney, Agent, or Firm—Mark D. Patrick

[57] ABSTRACT

A power supply control apparatus (113) for an electronic device (102) includes a terminal (115) to couple to a battery (103), a connector (122) to couple to an external power supply (172), a switch circuit (140) coupled to the terminal (115) and the connector (122), and a controller (108) coupled to the switch circuit (140). The switch circuit (140) connects the terminal (115) to power the electronic device (102) from the terminal (115) when the battery (103) is attached and disconnects the terminal (115) to power the electronic device (102) from the connector (122) when the external power supply (172) is attached. The controller (108) selectively controls the switch circuit (140) to connect the connector (122) to the terminal (115) so as to charge the battery (103) from the external power supply (172).

20 Claims, 2 Drawing Sheets

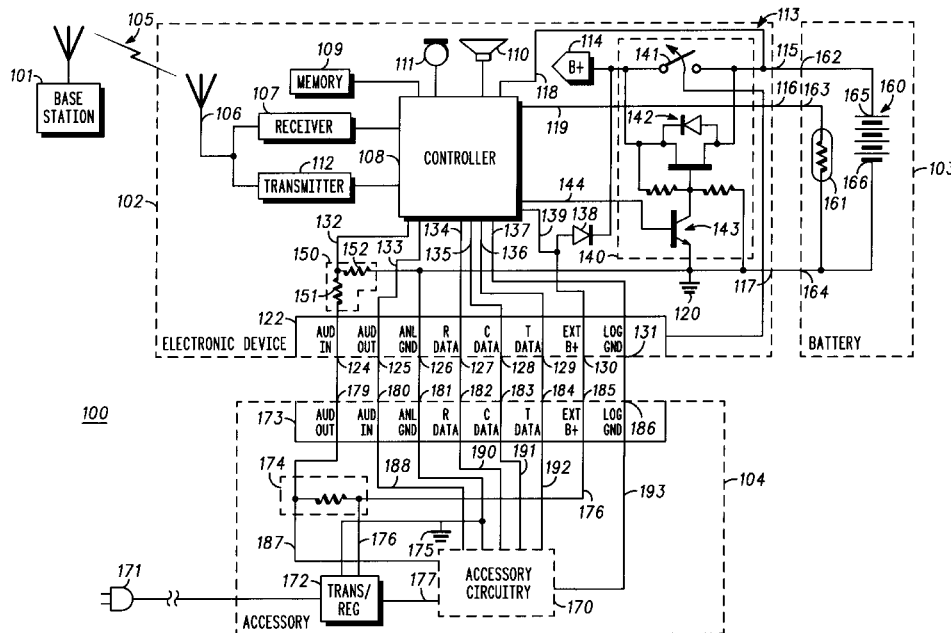

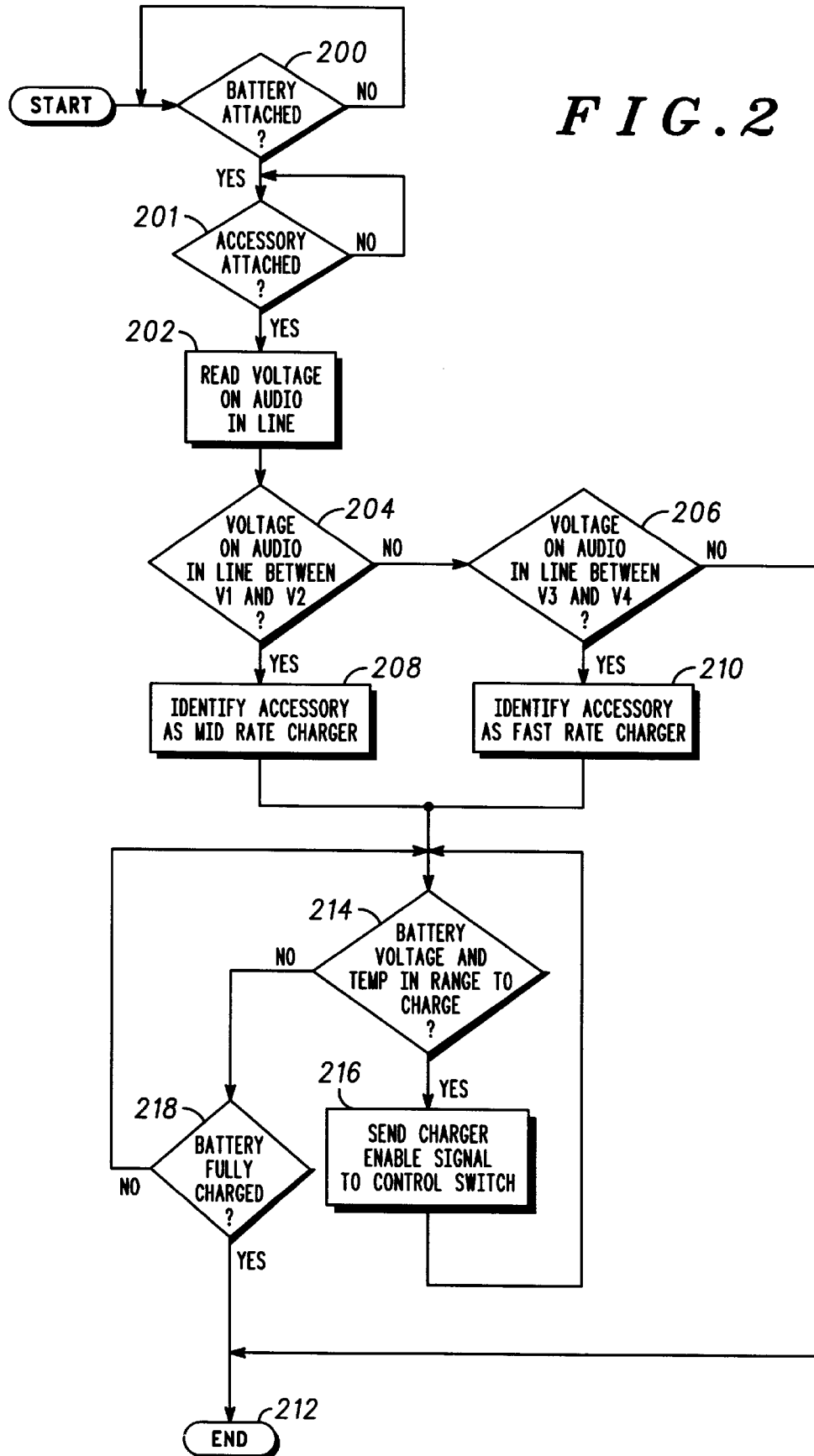

**POWER SUPPLY CONTROL APPARATUS
AND METHOD SUITABLE FOR USE IN AN
ELECTRONIC DEVICE**

FIELD OF THE INVENTION

This invention relates generally to electronic devices and, more particularly, to an apparatus and method used by an electronic device for controlling power supplied thereto.

BACKGROUND OF THE INVENTION

Electronic devices, such as cellular telephones, must be supplied with power in order to operate. A detachable battery is used to supply power to the device, particularly when portability of the device is desired. The battery is secured to the device via a battery connector. The battery supplies power to the device until depletion occurs. Once depleted, the battery must be replaced or recharged if portable operation of the device is to continue. If no replacement battery is available and portability is not a concern, operation of the device may be continued by attaching an accessory to the device.

Accessories are attached to the device via an accessory connector of the device, such as the standardized eight pin J3-type accessory connector used in MicroTAC™ cellular telephones manufactured and sold by Motorola, Inc. from 1989 to the present. The J3-type accessory connector has an external power supply pin; an audio in pin; an audio out pin; data pins for high speed data communications according to the three-wire bus protocol used in radiotelephone products by Motorola, Inc.; and two grounding pins in a predetermined arrangement. To be compatible with the J3-type accessory connector, an accessory must have a connector that is designed to mate with the accessory connector and have the same number and arrangement of pins. Upon attachment of the accessory to the device, the battery is electrically disconnected by an internal switch arrangement employed by the device and the device is powered solely by the accessory, which couples power transformed from an automobile electrical system or a conventional wall socket to the external power supply pin.

Unfortunately, because the battery is disconnected upon attachment of the accessory, charging of the battery can not be accomplished via the accessory connector as described. In the past, charging of the battery was performed by detaching the battery from the battery connector of the device and placing it in a standalone charger or by providing a dedicated charger connector on the device separate from, and in addition to, the accessory connector and the battery connector that fed a current source circuit disposed in the device. The standalone charger lacked portability, while the dedicated charger connector and current source circuit added cost and complexity to the device. Therefore, what is needed is a low cost apparatus and method that permits charging of the battery by the device and maintains backward compatibility with past accessories that mate with the accessory connector of the device.

BRIEF DESCRIPTION OF THE DRAWINGS

FIG. 1 illustrates, in partial block and partial schematic diagram form, a charging system including an electronic device having a power supply control apparatus, a battery, and an accessory; and

FIG. 2 illustrates, in flow chart form, a power supply control method implemented by the electronic device of FIG. 1.

**DETAILED DESCRIPTION OF THE
PREFERRED EMBODIMENTS**

A power supply control apparatus for an electronic device includes a terminal to couple to a battery, a connector to couple to an external power supply, a switch circuit coupled to the terminal and the connector, and a controller coupled to the switch circuit. The switch circuit connects the terminal to power the electronic device from the terminal when the battery is attached and disconnects the terminal to power the electronic device from the connector when the external power supply is attached. The controller selectively controls the switch circuit to connect the connector to the terminal so as to charge the battery from the external power supply. By using the external power supply, previously used only to power the electronic device, to also charge the battery, a low cost and backwards compatible charging system is realized.

FIG. 1 illustrates a charging system 100. The charging system 100 includes an electronic device 102, a battery 103, and an accessory 104. The electronic device 102 communicates with a base station 101, which provides wireless communications and features, such as paging, telephone, and short messaging, or the like, to the electronic device 102 when it is located within a geographic area served by the base station 101. The base station 101 and the electronic device 102 communicate with each other via a communication link, which is preferably radio frequency (RF) signals 105. In the illustrated embodiment, the electronic device 102 is a cellular telephone and the base station 101 is a cellular telephone service provider.

The electronic device 102 includes an antenna 106, a receiver 107, a controller 108, a memory 109, a speaker 110, a microphone 111, and a transmitter 112. The controller 108 includes a microprocessor, such as a 68HC11 microprocessor commercially available from Motorola, Inc., known synthesizer circuitry, and known audio logic circuitry. The controller 108 controls the operation of the electronic device 102 according to instructions read from the memory 109. The antenna 106 detects and emits the RF signals 105. The receiver 107 operates under control of the controller 108 to convert signals received by the antenna 106 into data signals input to the controller 108 for use thereby and into voice signals input to the controller 108 for output by the speaker 110 as audible speech. The transmitter 112 operates under control of the controller 108 to convert signals, which include data signals generated by the controller 108 and voice signals generated by the controller 108 from audible speech input via the microphone 111, for emission by the antenna 106.

The electronic device 102 has a power supply control apparatus 113 that includes, aside from the controller 108, a supply terminal (B+) 114, battery terminals 115, 116, and 117, a connector 122, and a switch circuit 140. The supply terminal 114 supplies power to electrical circuitry of the electronic device 102, including but not limited to, the receiver 107, the controller 108, and transmitter 112 via electrical connections (not shown).

The battery terminals 115–117 are for electrically connecting to the battery 103. Battery terminals 115 and 116 are monitored by the controller 108 via lines 118 and 119. Battery terminal 117 is coupled to an analog ground 120 of the electronic device 102.

The connector 122 is for physically and electrically connecting to the accessory 104. The connector 122 has multiple pins including information pins 124, 125, 127, 128, and 129 designated AUD IN, AUD OUT, and R, C, and T DATA, respectively; grounding pins 126 and 131 designated

ANL GND and LOG GND; and an external power supply pin 130 designated EXT B+. The information pin 124 is coupled to the controller 108 via audio in line 132 and an identification network 150. The identification network 150 is employed to identify the accessory 104. In the illustrated embodiment, the identification network 150 includes a resistor 151, having a value of 15 k Ω , coupled in series with the information pin 124 and the audio in line 132 and a resistor 152, having a value of 15 k Ω , coupled to the audio in line 132 and the analog ground 120 in a shunt configuration, which give the identification network 150 an impedance of approximately 30 k Ω looking in from the information pin 124. The information pin 125 is coupled to the controller 108 via audio out line 133. The information pins 127–129 are coupled to the controller 108 via data lines 134–136. The grounding pins 126 and 131 are coupled to the analog ground 120 and to a logic ground of the controller 108 via line 137, respectively. The external power supply pin 130 is coupled to the supply terminal 114 via a diode 138. The external power supply pin 130 is monitored by the controller 108 via line 139. The connector 122 is preferably the standardized eight pin J3-type accessory connector employed by MicroTAC™ cellular telephones manufactured and sold by Motorola, Inc. from 1989 to the present, but may be any other suitable multiple pin accessory connector having an external power supply pin and at least one information pin.

The switch circuit 140 selectively connects the battery terminal 115 to the supply terminal 114. The switch circuit 140 includes a mechanical switch 141, a transistor switch 142, and a control switch 143. The mechanical switch 141 is coupled to the connector 122, the supply terminal 114, and the battery terminal 115. The mechanical switch 141 electrically connects the supply and battery terminals 114 and 115 when the connector 122 is unattached and opens to electrically disconnect the supply and battery terminals 114 and 115 when the accessory 104 is physically attached to the connector 122.

The transistor switch 142 is coupled in parallel with the mechanical switch 141 to prevent interruption of power to the electronic device 102 when the mechanical switch 141 is opened or closed. The transistor switch 142 provides a conduction path between the supply and battery terminals 114 and 115 until a voltage level at the supply terminal 114 meets or exceeds a voltage level at the battery terminal 115 causing the transistor switch 142 to turn off. The transistor switch 142 is preferably a MOSFET (metal-oxide semiconductor field effect transistor) having gate and drain terminals coupled to the supply terminal 114, a source terminal coupled to battery terminal 115, and an intrinsic diode coupled across the source and drain terminals. One skilled in the art will recognize that the mechanical switch 141 in the aforementioned arrangement is redundant and the desired switching of the supply and battery terminals 114 and 115 can be accomplished using only the transistor switch 142.

The control switch 143 is coupled to the transistor switch 142 and the controller 108 via line 144 to selectively control the transistor switch 142. In response to an enable signal on line 144, the control switch 143 turns on and pulls the gate of the transistor switch 142 low, which in turn forces the transistor switch 142 to turn on and provide a current conduction path between the supply and battery terminals 114 and 115. The control switch 143 is preferably a BJT (bipolar junction transistor) having a collector terminal coupled to the gate of the transistor switch 142, a base coupled to the controller 108 via line 144, and an emitter coupled to the analog ground 120.

Although electronic device 102 is illustrated as a cellular telephone, the present invention will also find application in radios, portable computers, cordless telephones, two-way radios, pagers, personal digital assistants, tape recorders, and the like, and “electronic device” as used herein shall refer to all such battery powered electronic devices and their equivalents.

The battery 103 includes an electrochemical cell 160, a thermistor 161, and contacts 162–164. The electrochemical cell 160 includes a positive polarity terminal 165 coupled to contact 162 and a negative polarity terminal 166 coupled to contact 164. The electrochemical cell 160 is preferably rechargeable, and can be, for example, any one of the following chemical types: Nickel-Cadmium (NiCd), Nickel-Metal Hydride (NiMH), Alkaline, or Lithium Ion. In the illustrated embodiment, the electrochemical cell 160 supplies a battery voltage supply, preferably of 6 V DC (direct current), at the positive polarity terminal 165. The thermistor 161 is coupled to the contacts 163 and 164. A voltage level across the thermistor 161 forms a temperature signal corresponding to the temperature of the electrochemical cell 160.

The accessory 104 has a plug 171, a transformer and regulator 172, a connector 173, and an identification element 174. The accessory 104 can be a modem, a hands-free car kit, a battery saver, or the like, and include accessory circuitry 170. The accessory circuitry 170 can include a microprocessor requiring a logic ground; and data or audio input/output devices such as a keypad, a microphone, or a speaker requiring a connection to an analog ground 175 of the accessory 104. However, in the illustrated embodiment, the accessory 104 is a low cost mid rate charger or fast rate charger that does not include the accessory circuitry 170.

The plug 171 is compatible to mate with a conventional wall outlet (not shown) and provide external power (e.g., 110 V AC (alternating current) supply) to the accessory 104 from the outlet. Alternatively, the plug 171 could be compatible to mate with a cigarette lighter port to provide power to the accessory 104 from an automobile electrical system, or with another suitable power supply.

The transformer and regulator 172 is coupled to the plug 171 and has conventional circuitry. The transformer and regulator 172 provides an external power supply to connector 173 via line 176. In the illustrated embodiment, the external power supply is a current limited constant voltage supply supplying an 8.6 V DC output voltage for both the mid and fast rate chargers, a 340 mA current for the mid rate charger, and a 850 mA current for the fast rate charger. The transformer and regulator 172 preferably includes a tracking circuit that adjusts output power according to feedback received on line 176. In the event that the accessory 104 has the accessory circuitry 170, the transformer and regulator 172 outputs regulated power on line 177 to power the accessory circuitry 170. The transformer and regulator 172 is coupled to the analog ground 175.

The connector 173 is for physically and electrically connecting to the connector 122 of the electronic device 102. The connector 173 has multiple pins including information pins 179, 180, 182, 183, and 184 designated AUD OUT, AUD IN, and R, C, and T DATA, respectively; grounding pins 181 and 186 designated ANL GND and LOG GND; and an external power supply pin 185 designated EXT B+. The information pins 179 and 180 are coupled to an audio out line 187 and an audio in line 188, respectively. The information pins 181–183 are coupled to data lines 190–192. The grounding pins 181 and 186 are coupled to the analog ground 175 and logic ground line 193, respectively. The

Explore Litigation Insights

Docket Alarm provides insights to develop a more informed litigation strategy and the peace of mind of knowing you're on top of things.

Real-Time Litigation Alerts



Keep your litigation team up-to-date with **real-time alerts** and advanced team management tools built for the enterprise, all while greatly reducing PACER spend.

Our comprehensive service means we can handle Federal, State, and Administrative courts across the country.

Advanced Docket Research



With over 230 million records, Docket Alarm's cloud-native docket research platform finds what other services can't. Coverage includes Federal, State, plus PTAB, TTAB, ITC and NLRB decisions, all in one place.

Identify arguments that have been successful in the past with full text, pinpoint searching. Link to case law cited within any court document via Fastcase.

Analytics At Your Fingertips



Learn what happened the last time a particular judge, opposing counsel or company faced cases similar to yours.

Advanced out-of-the-box PTAB and TTAB analytics are always at your fingertips.

API

Docket Alarm offers a powerful API (application programming interface) to developers that want to integrate case filings into their apps.

LAW FIRMS

Build custom dashboards for your attorneys and clients with live data direct from the court.

Automate many repetitive legal tasks like conflict checks, document management, and marketing.

FINANCIAL INSTITUTIONS

Litigation and bankruptcy checks for companies and debtors.

E-DISCOVERY AND LEGAL VENDORS

Sync your system to PACER to automate legal marketing.