

[54] VIDEO SIGNAL PROCESSING APPARATUS FOR CORRECTING FOR CAMERA VIBRATIONS USING CCD IMAGER WITH A NUMBER OF LINES GREATER THAN THE NTSC STANDARD

Primary Examiner—Michael T. Razavi
Assistant Examiner—Tuan Y. Ho
Attorney, Agent, or Firm—Jay H. Maioli

[75] Inventor: Shigeki Ishizuka, Kanagawa, Japan

[73] Assignee: Sony Corporation, Tokyo, Japan

[21] Appl. No.: 395,900

[22] Filed: Feb. 28, 1995

Related U.S. Application Data

[62] Division of Ser. No. 70,957, Jun. 4, 1993, Pat. No. 5,396,286.

[30] Foreign Application Priority Data

Jun. 9, 1992 [JP] Japan ..... 4-174896

[51] Int. Cl. 6 ..... H04N 5/228

[52] U.S. Cl. .... 348/208; 348/294; 348/316

[58] Field of Search ..... 348/208, 207, 348/240, 294, 155, 699, 700, 303, 304, 311, 316; 359/554; 354/70; H04N 5/228

[56] References Cited

U.S. PATENT DOCUMENTS

4,963,981 10/1990 Todaka et al. .... 348/240
5,253,071 10/1993 Mackay ..... 348/208

[57] ABSTRACT

A video signal processing apparatus for correcting vibration effects in a video camera that has a CCD image pickup device having a number of lines greater than the number of lines of the standard NTSC television system. The lines used to generate the image are shifted during the vertical blanking interval to correct for vibrations of the video camera, and the overflow charges which are caused by transferring the CCD image pickup device at a high speed during the blanking period are absorbed into a semiconductor drain element arranged in parallel with the horizontal transfer register of the CCD image pickup device. Defective pixels in the image pickup device are compensated by storing the addresses of defective pixels and interpolating at those positions, during vibration correction the addresses of the defective pixels are shifted to correspond to the amount of vibration correction. A read clock and a write clock for the line memory that is used to perform the vibration correction in the horizontal direction are set to line-locked clock signals of different frequencies, thereby preventing deterioration of the picture quality upon vibration correction. The window used to detect optical information for automatic camera control is also shifted in accordance with the shift amount used to perform vibration correction.

3 Claims, 9 Drawing Sheets

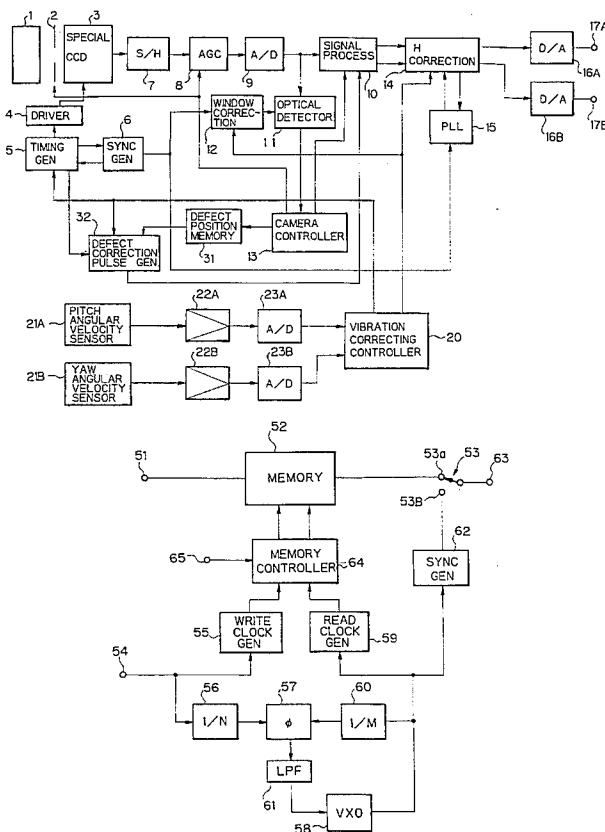

Fig. 1

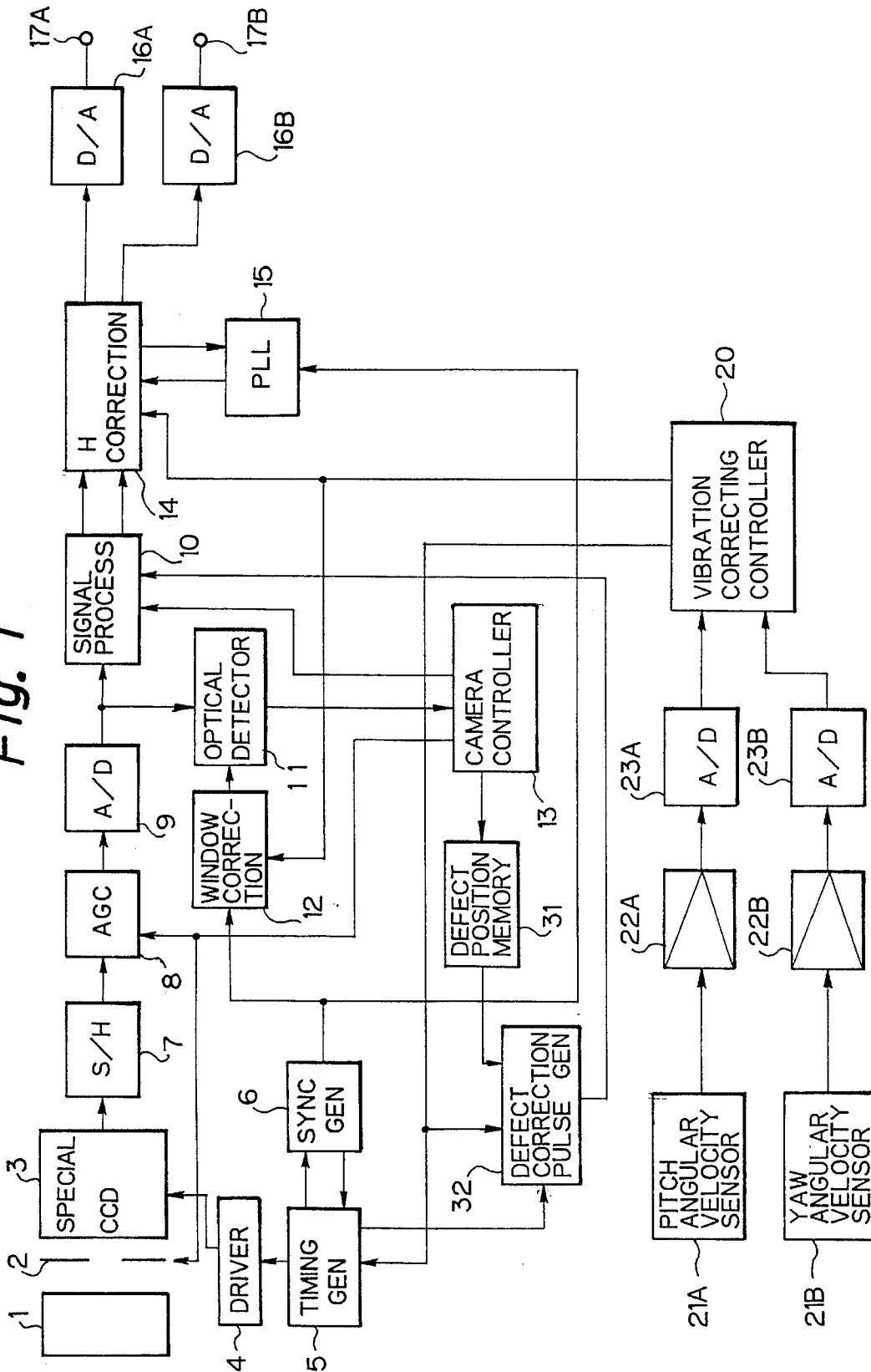

Fig. 2

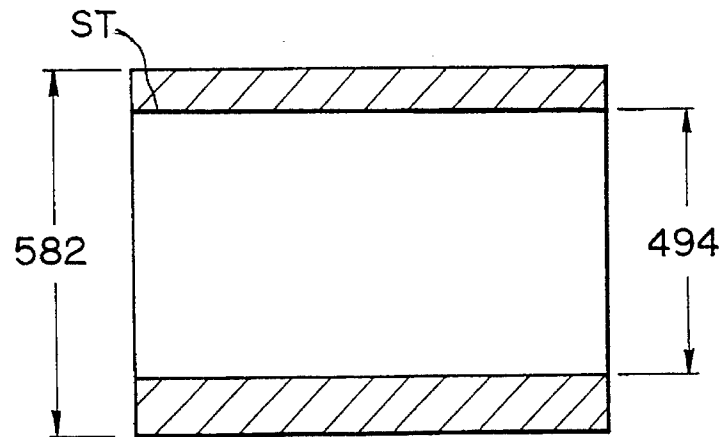

Fig. 4

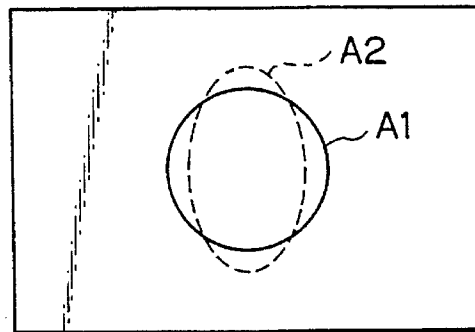

Fig. 5A

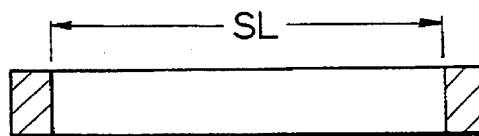
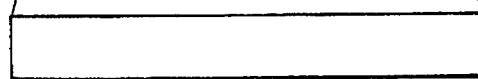

Fig. 5B



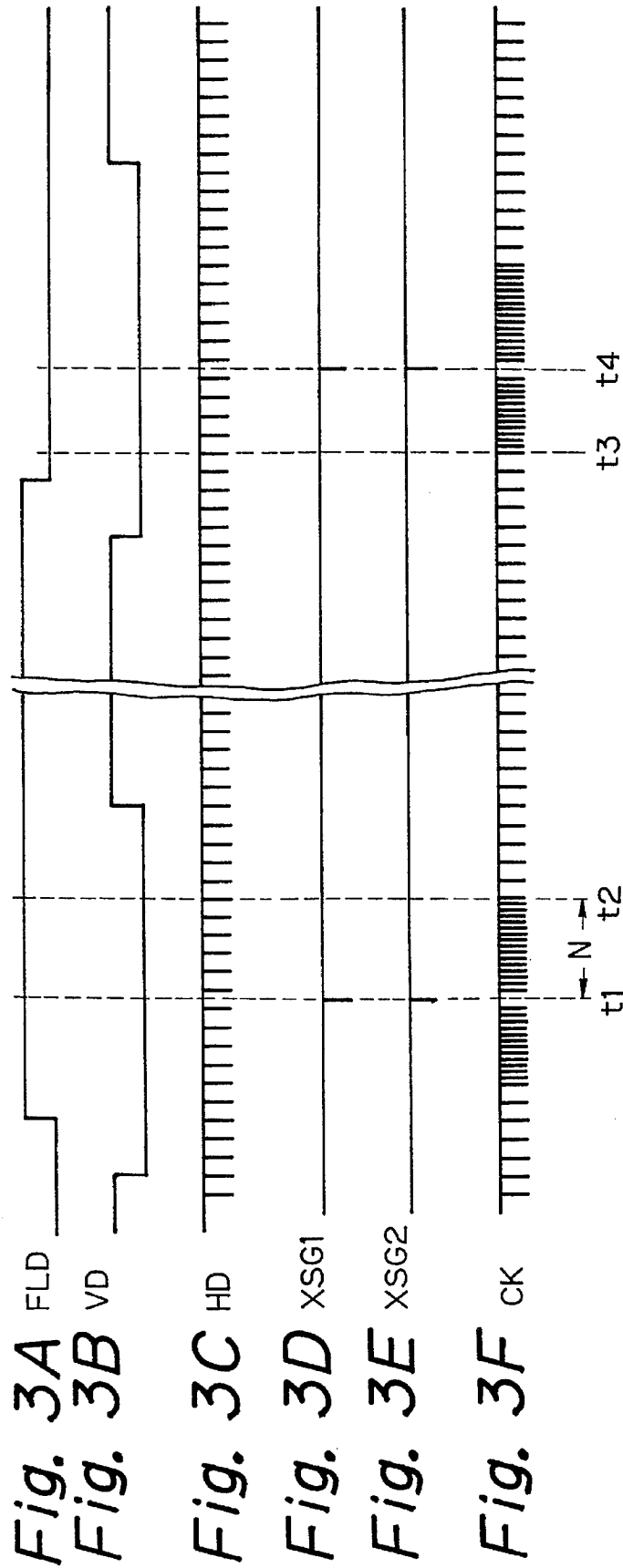

Fig. 3A FLD

Fig. 3B VD

Fig. 3C HD

Fig. 3D XSG1

Fig. 3E XSG2

Fig. 3F CK

Fig. 6

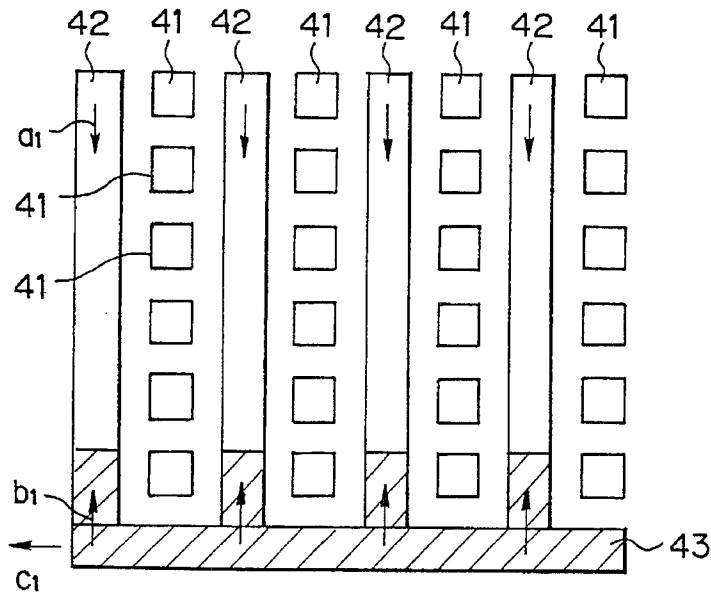

Fig. 7

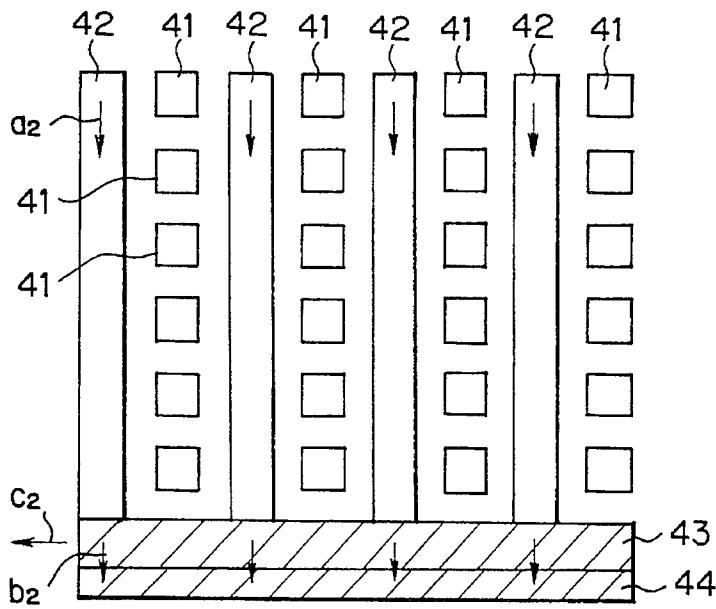
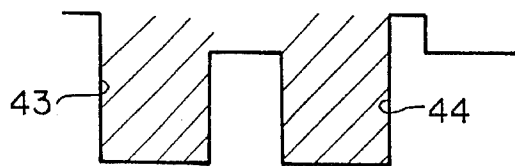

Fig. 8



# Explore Litigation Insights

Docket Alarm provides insights to develop a more informed litigation strategy and the peace of mind of knowing you're on top of things.

## Real-Time Litigation Alerts



Keep your litigation team up-to-date with **real-time alerts** and advanced team management tools built for the enterprise, all while greatly reducing PACER spend.

Our comprehensive service means we can handle Federal, State, and Administrative courts across the country.

## Advanced Docket Research



With over 230 million records, Docket Alarm's cloud-native docket research platform finds what other services can't. Coverage includes Federal, State, plus PTAB, TTAB, ITC and NLRB decisions, all in one place.

Identify arguments that have been successful in the past with full text, pinpoint searching. Link to case law cited within any court document via Fastcase.

## Analytics At Your Fingertips



Learn what happened the last time a particular judge, opposing counsel or company faced cases similar to yours.

Advanced out-of-the-box PTAB and TTAB analytics are always at your fingertips.

## API

Docket Alarm offers a powerful API (application programming interface) to developers that want to integrate case filings into their apps.

## LAW FIRMS

Build custom dashboards for your attorneys and clients with live data direct from the court.

Automate many repetitive legal tasks like conflict checks, document management, and marketing.

## FINANCIAL INSTITUTIONS

Litigation and bankruptcy checks for companies and debtors.

## E-DISCOVERY AND LEGAL VENDORS

Sync your system to PACER to automate legal marketing.