

17231 U.S. PTO  
08/26/03

Landmark Building - Newland Center  
1990 Beach Blvd., Suite C-2  
Huntington Beach, CA 92648  
BUS: (714) 378-0212  
FAX: (714) 378-0262

Law Offices of  
**DENNIS W. BEECH**

**RESPOND TO: HUNTINGTON BEACH**

17302 U.S. PTO  
10/648012  
08/26/03

Meridien Building  
1007 West Avenue M-14, Suite C-10  
Palmdale, California 93551  
BUS: (805) 273-0503  
FAX: (714) 378-0262

August 25, 2003

Mail Stop Patent Application  
Commissioner for Patents  
P.O. Box 1450  
Alexandria, VA 22313-1450

EV203842632US

Serial No.: 10/027,391  
Applicant: C. Earl Woolfork  
Filing Date: 12/21/2001  
Group Art Unit: 2644  
Examiner: McChesney, Elizabeth A.  
For: WIRELESS DIGITAL AUDIO SYSTEM

Dear Assistant Commissioner for Patents:

This amendment, and fee for CIP application are filed to maintain the parent case which is to be abandoned when filing a new application claiming its benefit.

1. The amendment in this case is a bona fide attempt by applicant to respond and to advance this application to final action and comprises a separately filed:
  - (a) \_\_\_ Continuation Application
  - (b) X Continuation-in-Part Application
  - (c) \_\_\_ Divisional Application (where parent case is to be abandoned).

A copy of this amendment and petition is being filed with the papers constituting the filing of the separately filed application.

2. The amendment being filed in this case is attached.
3. This is not a petition for extension of time to respond to:
  - (d) \_\_\_ the Office Action mailed on \_\_\_\_\_, and Advisory Action dated \_\_\_\_\_.

(e)  Other: The Office Action dated 02/26/2003 did not specify a shortened time period for reply.

4. Please abandon this application conditioned upon the granting of the petition and granting of a filing date to the continuing application so as to make the continuing application co-pending with this application.

5. Applicant is:

a small entity verified statement

is enclosed.

was filed in parent application (a copy attached) and this status is still proper and its benefit under 37 CFR 1.28 (a) is hereby claimed.

other than a small entity.

6. Extension requested under 37 CFR 1.17(c) is for \_\_\_\_\_ months to \_\_\_\_\_ for a fee of \$---.--.

7. Enclosed is:

Continuation-in-Part Patent Application including:

11 pages of specifications

2 pages of drawings

Small Entity Statement

Combination Declaration and Power of Attorney

Nonpublication Request

Proof of Mailing

Self Addressed Postcard

A check in the amount of \$375.00

This amount is based on:

5 claim and 3 independent claim	\$375.00
0 independent claims in excess of three (\$42.00)	0.00
0 claims in excess of twenty (\$9.00)	0.00

TOTAL FILING FEE:

\$375.00

Very truly yours,

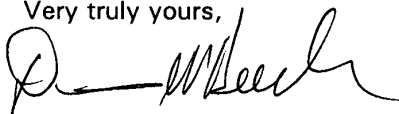

DENNIS W. BEECH

Reg. No.: 35,443

DWB/ab

Enclosures

## FUZZY AUDIO WIRELESS MUSIC SYSTEM

This is a continuation-in-part of application Serial No. 10/027,739  
which patent application is pending.

5

### BACKGROUND OF THE INVENTION

[0001] This invention relates to audio player devices and more particularly to systems that include headphone listening devices. The new audio system uses existing audio player device headphone jacks to connect a battery  
10 powered transmitter for wireless transmission of a signal to a battery powered receiving headphone.

[0002] Use of audio headphones with audio player devices such as radio, tape players, CD players, computers, television audio and the like have been in use for many years. These systems usually incorporate an audio source having  
15 a headphone jack to which a headphone may be connected by wire and connector.

[0003] There are also known wireless headphones that may receive A.M. and F.M. radio transmissions. However, these systems do not allow use of a simple plug in battery powered transmitter for connection to any audio player  
20 device jack, such as, laptop and desktop computers, portable compact disc players, portable MP3 players, portable cassette players and the like, for wireless transmission and reception of audio music for private listening to multiple users occupying the same space. Existing audio systems make use of electrical wire connections between the audio source and the headphones to  
25 accomplish private listening to multiple users.

[0004] There is a need for a battery powered simple connection system for existing audio player devices, to allow wireless transmission to a headphone receiver that accomplishes private listening to multiple users occupying the  
30 same space.

## SUMMARY OF THE INVENTION

5 [0005] The present invention is directed to FAWM (Fuzzy Audio Wireless Music) systems for coded digital transmission of an audio signal from any audio player device with a headphone jack to a receiver headphone using fuzzy logic technology. A battery powered digital transmitter may include a headphone plug in communication with any of the previously mentioned audio sources, 10 laptop and desktop computers, portable compact disc players, portable MP3 players, portable cassette players and the like. The FAWM system converts the audio music signal that may be supplied by the source, into a digital signal. This conversion takes place in the small battery powered transmitter that connects to the headphone jack of the source. The transmitter then adds a 15 unique user code and transmits it to the battery powered receiver headphones where the fuzzy logic detector decodes only the unique user code to allow private listening without interference from other users.

[0006] These and other features, aspects and advantages of the present invention will become better understood with reference to the following 20 drawings, description and claims.

## BRIEF DESCRIPTION OF THE DRAWINGS

[0007] Figure 1 illustrates a schematic diagram representation of the 25 FAWM system;

Figure 2 illustrates a graph of the high and low bit fuzzy logic if-then part fuzzy set according to an embodiment of the invention.

30



## DETAILED DESCRIPTION

**[0008]** The following detailed description is the best currently contemplated modes for carrying out the invention. The description is not to be taken in a limiting sense, but is made merely for the purpose of illustrating the general principles of the invention.

**[0009]** Referring to Figure 1, a FAWM system 10 may include a battery powered transmitter 20 connected to a portable audio player or audio source 80. The battery powered transmitter 20 may be connected to the audio source 80 headphone jack 82 using a headphone plug 22. The battery powered transmitter 20 may have a transmitting antenna 24 that may be omni-directional for transmitting a coded digital modulated signal to a receiving antenna 52 of a battery powered receiver 50 that may be a headphone receiver. The battery powered receiver 50 may have headphone speakers 54 in headphones 55 for listening to the demodulated and decoded digital signal. The FAWM transmitter 20 may digitize the audio signal. This digital signal has a throughput of approximately 1.4 Mbps, which may be determined by the analog to digital A/D converter sampling rate of 44.1kHz multiplied by 16 bit quantization. To reduce the effects of channel noise, the battery powered transmitter 20 may use convolutional encoding, and interleaving. For further noise immunity, spread spectrum modulation may be utilized. The battery powered transmitter 20 may contain a shift register generator (SRG) that may be used to create a unique user code. The unique user code generated is specifically associated with one FAWM user, and it is the only code recognized by the battery powered FAWM headphone receiver 50 of that particular user. The radio frequency (RF) spectrum utilized (as taken from the Industrial, Scientific and Medical (ISM) band), may be approximately 2.4 GHz. And the power radiated by the transmitter adheres to the ISM standard.

**[0010]** Referring to Figure 1, the digital modulated signal from transmit antenna 24 may be received by receiving antenna 52 and then demodulated,

decoded and deinterleaved in the battery powered receiver 50 headphones. The battery powered receiver 50 may utilize fuzzy logic to optimize the detection of the received user code.

5 **[0011]** Each receiver 50 user may be able to listen (privately) to high fidelity audio music, using any of the audio devices listed previously, without the use of wires, and without interference from any other receiver 50 user. Because of the fuzzy logic detection technique used in the wireless digital audio system, user separation through code division may be achieved.

10 **[0012]** The battery powered transmitter 20 sends the audio information to the battery powered receiver 50 in digital packet format. Each packet may consist of, at minimum, a start bit to indicate the beginning of a packet, the unique user code, the digitized audio information and a stop bit to indicate the end of a packet. These packets may flow to create a digital bit stream rate less than or equal to 1 Mb/s.

15 **[0013]** The user code bits in each packet may be received and detected by a fuzzy logic detector in the headset receiver 50. For each consecutive packet received, the fuzzy logic detector may compute a conditional density with respect to the context and fuzziness of the user code vector, i.e., the received user code bits in each packet. The fuzzy logic detector is the key component to  
20 the FAWM system 10. Because the fuzzy logic detector enables the battery powered FAWM receiver 50 to accurately detect the assigned user code in the presence of noise, which includes other FAWM users. Fuzziness may describe the ambiguity of the high (1)/low (0) bit event in the noisy received packet. Note that the fuzzy detector may measure the degree to which a high/low bit occurs  
25 in the user code vector, which produces a low probability of bit error in the presence of noise. The fuzzy detector may use a set of if-then rules to map the user code bit inputs to validation outputs. These rules may be developed as if-then statements.

30 **[0014]** The fuzzy logic detector in the battery powered receiver 50 utilizes the if-then fuzzy set to map the received user code bits into two values; a low

(0) and a high (1). Thus, as the user code bits are received, the "if" rules map the signal bit energy to the fuzzy set low value to some degree and to the fuzzy set high value to some degree. See Figure 2. Due to additive noise each user code bit (bit energy  $x$ ) may have some membership to a low and high as represented in Figure 2. Therefore, the if-part fuzzy set may determine if each bit in the user code, for every received packet, has a greater membership to a high bit representation or a low bit representation. The more a user code bit energy,  $x$  fits into the high or low representation, the closer its subsethood, i.e., a measure of the degree to which a set may be a subset of another set, may be to one. Note that Figure 2 shows that  $-1$  equals the maximum low bit energy representation and  $1$  equals the maximum high bit energy representation to illustrate that this design may utilize Manchester encoding/decoding schemes.

**[0015]** The received user code input bit in each packet may be:  
 $x(i)$ , where  $i = 1, 2, \dots, n$  is the set of all bits that make up the user code vector.  
 $X(c)$ , where  $c = 1, 2, \dots, m$  represents each user assigned a unique user code.  
So user  $X(1)$  has bit code  $[x(1) x(2) \dots x(n)]$  and user  $X(m)$  has bit code  $[x(1) x(2) \dots x(n)]$  which is different from user  $X(1)$ .

**[0016]** Each  $x$  in  $X$  may activate a fuzzy "if" rule. The if-part sets may be conditional densities, so the fuzzy "if" rule activates to the degree  $p[x(i)|X(c)] p[X(c)]$ , which is the probability of the user code bits  $x$  given the user vector  $X$  multiplied by the probability of  $X$ .

**[0017]** The then-part fuzzy rule set may be indirectly dependent on the input bits  $x$  in  $X$ . The then-part set may be a weighted sum equal to  $p[x(i)] p[y|x(i)]$ ,  $i = 1, 2, \dots, n$ .

**[0018]** Which is the probability of the user bit vector  $x$  multiplied by the probability of  $y$  given the user bit vector  $x$ . Where  $y$  may be a number representation to define the correct user headset battery powered receiver

given the input bit set  $x(i)$ ,  $i = 1, 2, \dots, n$ .

**[0019]** The if-then rule parts that make up the fuzzy logic detector must be followed by a defuzzifying operation. This operation reduces the output fuzzy set to a single number that determines if the correct received user code bits within the transmitted packet have been detected. The defuzzifying operation may be implemented with the modal method, i.e., calculation of the value that has the highest membership in the fuzzy set. With the modal method a strategy of clarity may be applied in the event that some user code energy bit values have equally high membership. The clarity of a fuzzy set may be considered by weighting the conditional densities discussed previously. The weighting determines relative fuzziness of the user code energy bit ( $x$ ) that gives a measure of the uncertainty of the unique user code vector. As a result, the fuzzy logic detector used in the battery powered headset receiver 50 greatly reduces the unique user code bit error probability. The fuzzy logic detector technique, combined with convolutional error detection and correction techniques, may enable the FAWM system 10 to operate in most any environment.

**[0020]** While the invention has been particularly shown and described with respect to the illustrated and preferred embodiments thereof, it will be understood by those skilled in the art that the foregoing and other changes in form and details may be made therein without departing from the spirit and scope of the invention.

25

## CLAIMS

I claim:

1. A fuzzy audio wireless music system for wireless transmission of a signal from an audio source to a battery powered headphone receiver comprising:

a headphone jack from an audio source in communication with a connectable battery powered transmitter;

said connectable battery powered transmitter contains an A/D converter wherein said A/D converter converts an analog music audio signal to a digital signal at a signal rate of approximately 1.4 Mbps;

said A/D converter in communication with a shift register generator, a convolutional encoder and an interleaver;

said interleaver in communication with a spread spectrum modulator;

said spread spectrum modulator in communication with a transmit antenna for wireless transmission of a coded digital signal to a receiving antenna at a radio frequency of approximately 2.4 GHz;

said receiving antenna in communication with a spread spectrum demodulator, a convolutional deinterleaver and a decoder; and

said decoder in communication with a fuzzy logic detector.

2. The fuzzy audio wireless music system as in claim 1 wherein said battery powered headphone receiver having said fuzzy logic detector with a detection method, comprising the steps of:

a) receiving a user code having:

$x(i)$  where  $i = 1, 2, \dots, n$  is the set of all bits that make up

the user code vector;

$X(c)$ , where  $c = 1, 2, \dots, m$  represents each user assigned

unique user code;

Wherein user X(1) has bit code [x(1) x (2)... X(n)] and user X(m) has bit code [x(1) x(2) ... x(n)] which is different form X(1);

b) activating a fuzzy if rule based on each x in X wherein the if part sets are conditional densities to activate the if rule to the degree  $p[x(i)|X(c)]$   $p[X(c)]$ ;

c) activating a fuzzy then rule indirectly dependent on each x in X wherein the then part sets are a weighted sum equal to  $p[x(i)]p[y|x(i)]$ ,  $i = 1, 2, \dots, n$ ; and

d) performing a defuzzifying operation of modal type.

3. A battery powered headphone receiver having a fuzzy logic detector method, comprising the steps of:

a) receiving a user code having:

x(i) where  $i = 1, 2, \dots, n$  is the set of all bits that make up the user code vector;

X(c), where  $c = 1, 2, \dots, m$  represents each user assigned unique user code;

wherein user X(1) has bit code [x(1) x (2)... X(n)] and user X(m) has bit code [x(1) x(2) ... x(n)] which is different form X(1);

b) activating a fuzzy if rule based on each x in X wherein the if part sets are conditional densities to activate the if rule to the degree  $p[x(i)|X(c)]$   $p[X(c)]$ ;

c) activating a fuzzy then rule indirectly dependent on each x in X wherein the then part sets are a weighted sum equal to  $p[x(i)]p[y|x(i)]$ ,  $i = 1, 2, \dots, n$ ; and

d) performing a defuzzifying operation of modal type.

4. A method for battery powered digital wireless transmission and reception of high fidelity audio music between a battery operated transmitter

and a battery operated receiver comprising the step of:

connecting a headphone plug attached to said battery operated transmitter to a headphone jack of an audio source;

converting an music audio signal to a digital signal using an A/D converter having a sampling rate of approximately 44.1 kHz multiplied by 16 bit quantization to produce a signal rate of approximately 1.4 Mbps;

encoding the digital signal using a convolutional encoding and interleaving method;

creating a spread spectrum signal using a shift register generator to modulate a unique user code;

transmitting said spread spectrum signal at a radio frequency of approximately 2.4 GHz at a power level that adheres to the ISM standard for reception at a distance of up to approximately 10 feet from said battery operated transmitter;

receiving said spread spectrum signal at said battery operated receiver headphones;

demodulating said spread spectrum signal and optimal bit detecting of said unique user code using fuzzy logic technology;

convolutional decoding and deinterleaving to receive said digital signal;

converting said digital signal to said analog music audio signal;

and

communication said analog music audio signal to a headphone speaker.

5. The battery powered receiver headphone as in claim 4 wherein said receiver having a fuzzy logic detector method comprising the steps of:

a) receiving a user code having:

$x(i)$  where  $i = 1, 2, \dots, n$  is the set of all bits that make up the user code vector;

$X(c)$ , where  $c = 1, 2, \dots, m$  represents each user assigned unique user code;

Wherein user  $X(1)$  has bit code  $[x(1) x(2) \dots x(n)]$  and user  $X(m)$  has bit code  $[x(1) x(2) \dots x(n)]$  which is different from  $X(i)$ ;

b) activating a fuzzy if rule based on each  $x$  in  $X$  wherein the if part sets are conditional densities to activate the if rule to the degree  $p[x(i)|X(c)]$   $p[X(c)]$ ;

c) activating a fuzzy then rule indirectly dependent on each  $x$  in  $X$  wherein the then part sets are a weighted sum equal to  $p[x(i)]p[y|x(i)]$ ,  $i = 1, 2, \dots, n$ ; and

d) performing a defuzzifying operation of modal type.



## FUZZY AUDIO WIRELESS MUSIC SYSTEM

### ABSTRACT OF THE DISCLOSURE

5 [0021] The fuzzy audio wireless music system may utilize a battery  
powered transmitter to transmit a coded digital signal from an audio player  
device or source to a battery powered headphone receiver without the use of  
wires. A battery powered digital transmitter may include a headphone plug in  
communication with any audio source, such as, laptop and desktop computers,  
10 portable compact disc players, portable MP3 players, portable cassette players,  
etc. The battery powered transmitter adds a unique user code and transmits it  
to the battery powered receiver headphones where a fuzzy logic detector  
decodes only the unique user code to allow private listening without  
interference from other users.

15

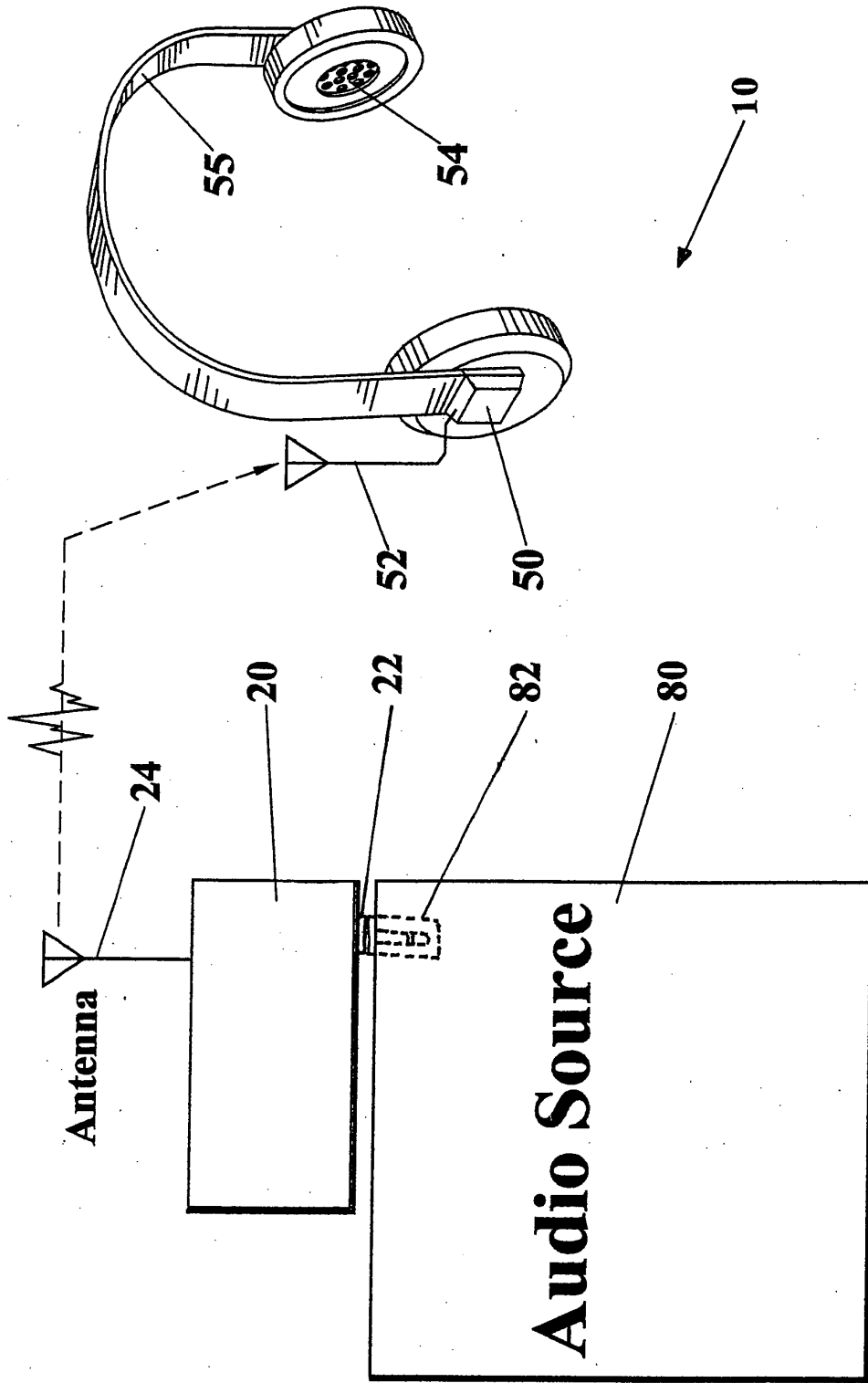

**FIG 1**

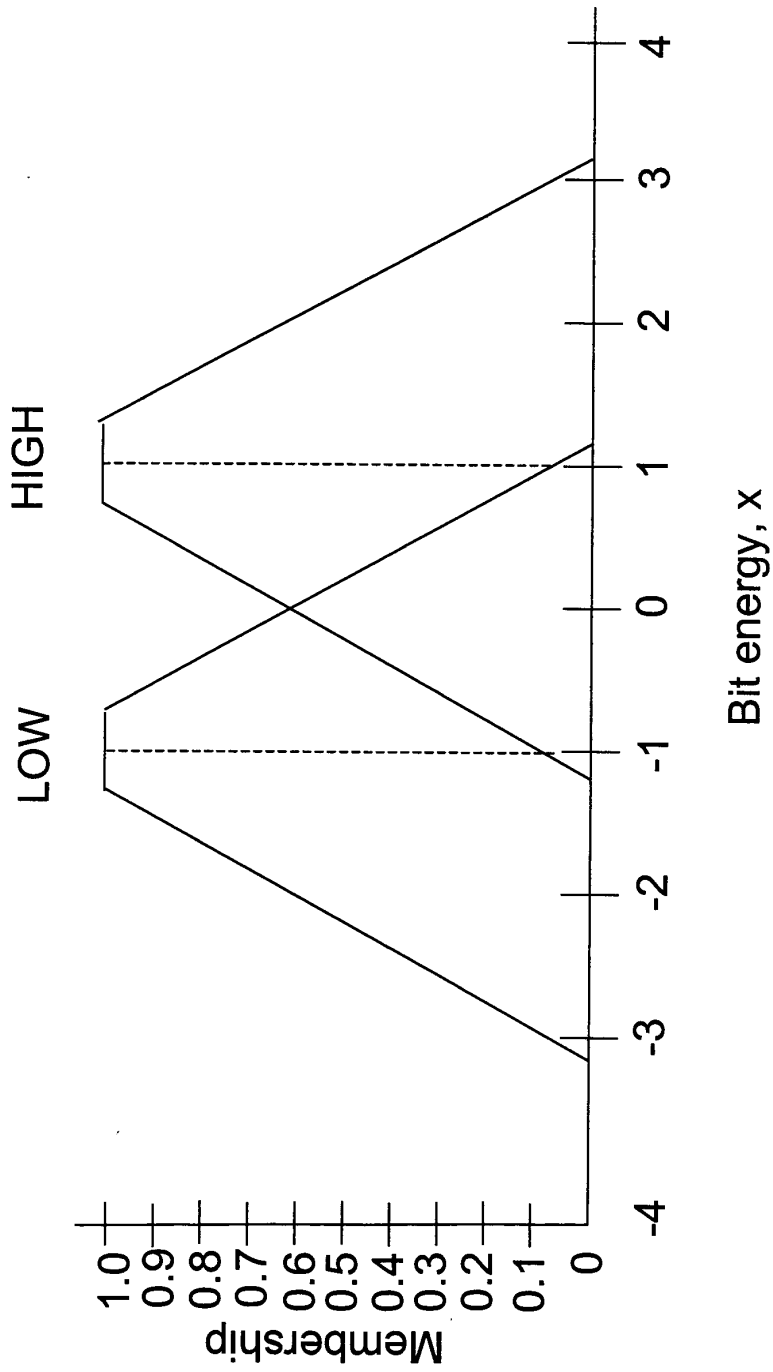

Figure 2

## POWER OF ATTORNEY

As the named inventor, I hereby appoint the following attorney to prosecute this application and transact all business in the Patent and Trademark Office and as agent or common representative to act on behalf of the applicant before the competent International authorities.

Dennis W. Beech, Reg. No. 35,443  
LAW OFFICES OF DENNIS W. BEECH  
19900 Beach Blvd., Suite C-2  
Huntington Beach, CA 92648  
(714) 378-0212

### DECLARATION

I hereby declare that all statements made herein of my own knowledge are true and that all statements made on information and belief are believed to be true; and further that these statements were made with the knowledge that willful false statements and the like so made are punishable by fine or imprisonment, or both under Section 1001 of Title 18 of the United States code and that such willful false statement may jeopardize the validity of the application or any patent issue thereon.

Country of Citizenship: United States of America

Residence: 500 Santa Paula Ave, Pasadena CA 91107

Post Office address: Same as above

Full name of sole or first inventor: C. Earl Woolfork

Inventor's signature: 

Date: 8/20/03

## COMBINATION DECLARATION AND POWER OF ATTORNEY

As the below named inventor, I hereby declare that this declaration is an original.

### INVENTORSHIP IDENTIFICATION

My residence, post office address and citizenship are as stated below next to my name, I believe I am the original, first and sole inventor of the subject matter which is claimed and for which a patent is sought on the invention entitled: **FUZZY AUDIO WIRELESS MUSIC SYSTEM**.

### SPECIFICATION IDENTIFICATION

The specification is attached hereto.

### ACKNOWLEDGEMENT OF REVIEW OF PAPERS AND DUTY OF CANDOR

I hereby state that I have reviewed and understand the contents of the above identified specification, including the claims, as amended by any amendment referred to above. I acknowledge the duty to disclose information which is material to the examination of this application in accordance with Title 37, Code of Federal Regulations, Section 1.56(a), including information that occurred between the filing date of the prior application and the national filing date of the continuation-in-part application.

### PRIORITY CLAIM

I hereby claim foreign priority benefits under Title 35, United States Code, Section 119 of any foreign application(s) for patent or inventor's certificate or of any PCT international application(s) designating at least one country other than the United States of America listed below and have also identified below any foreign application(s) for patent or inventor's certificate or any PCT international application(s) designating at least one country other than the United States of America filed by me on the same subject matter having a filing date before that of the application(s) of which priority is claimed.

No such applications have been filed.

Dated: \_\_\_\_\_

8/20/03

  
C. EARL WOOLFORK

Applicant or Patentee: C. Earl Woolfork  
Serial or Patent No.: 10/027,391  
Filed or Issued: 12/21/2001  
For: FUZZY AUDIO WIRELESS MUSIC SYSTEM

**VERIFIED STATEMENT (DECLARATION) CLAIMING SMALL ENTITY  
STATUS (37 CFR 1.9 (f) AND 1.27 (b))--INDEPENDENT INVENTOR**

As the below named inventor, I hereby declare that I qualify as an independent inventor as defined in 37 CFR 1.9(c) for purposes of paying reduced fees under Section 41 (a) and (b) of Title 35, United States Code, to Patent and Trademark Office with regard to the invention entitled **FUZZY AUDIO WIRELESS MUSIC SYSTEM** described in the specification filed herewith.

I have not assigned, granted, conveyed or licensed and I am under no obligation under contract or law to assign, grant, convey or license, any rights in the invention to any person who could not be classified as an independent inventor under 37 CFR 1.9(c) if that person had made the invention, or to any concern which would not qualify as a small business concern under 37 CFR 1.9(d) or a nonprofit organization under 37 CFR 1.9(e).

Each person, concern or organization to which I have assigned, granted, conveyed, or license or are under an obligation under contract or law to assign, grant, convey, or license any rights in the invention is listed below:

No such person.

I acknowledge the duty to file, in this application or patent, notification of any change in status resulting in loss of entitlement to small entity status prior to paying or at the time of paying, the earliest of the issue fee or any maintenance fee due after the date on which status as a small entity is no longer appropriate. (37 CFR 1.28(b)).

I hereby declare that all statements made herein of my own knowledge are true and that all statements made on information and belief are believed to be true; and further that these statements were made with the knowledge that willful false statements and the like so made are punishable by fine or imprisonment, or both, under Section 1001 of Title 18 of the United States Code, and that such willful false statements may jeopardize the validity of the application, and patent issuing thereon, or any patent to which this verified statement is directed.

Date 8/20/03

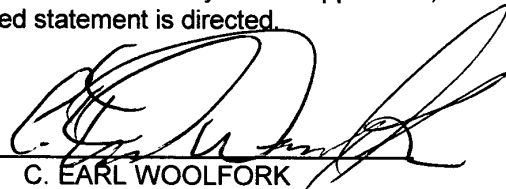
  
C. EARL WOOLFORK

**NONPUBLICATION REQUEST  
UNDER  
35 U.S.C. 122(b)(2)(B)(i)**

First Named Inventor: C. Earl Woolfork

Title: FUZZY AUDIO WIRELESS MUSIC SYSTEM

Atty Docket Number:

\_\_\_\_\_

I hereby certify that the invention disclosed in the attached application **has not and will not be** the subject of an application filed in another country, or under a multilateral agreement, that requires publication at eighteen months after filing.

**I hereby request that the attached application not be published under 35 U.S. C. 122(b).**

8/20/03  
Date

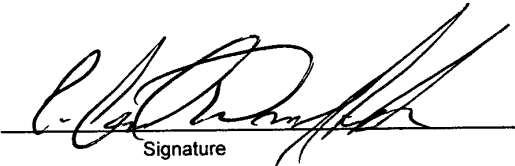
  
Signature

C. Earl Woolfork

This request must be signed in compliance with 37 CFR 1.33(b) and submitted with the application **upon filing**.

Applicant may rescind this nonpublication request at any time. If applicant rescinds a request that an application not be published under 35 U.S.C 122(b), the application will be scheduled for publication at eighteen months from the earliest claimed filing date for which a benefit is claimed.

If applicant subsequently files an application directed to the invention disclosed in the attached application in another country, or under a multilateral international agreement, that requires publication of applications eighteen months after filing, the applicant **must** notify the United States Patent and Trademark Office of such filing within forty-five (45) days after the date of the filing of such foreign or international application. **Failure to do so will result in abandonment of this application (35 U.S.C. 122(b)(2)(B)(iii)).**

IN THE UNITED STATES PATENT AND TRADEMARK OFFICE

In regards to application of:

Applicant: C, EARL WOOLFORK

Application: WIRELESS DIGITAL AUDIO SYSTEM

Mail Stop Patent Application  
Commissioner for Patents  
P.O. Box 1450  
Alexandria, VA 22313-1450

-----  
**EXPRESS MAIL CERTIFICATE MAILING UNDER 37 CFR § 1.10**

"Express Mail" label number: EV 203842632

Date of Deposit: August 25, 2003

I hereby certify that the following attached correspondence comprising:

11 pages of specifications  
2 pages of drawings  
2 pages of transmittal letter  
Combination Declaration & Power of Attorney  
Small Entity Declaration  
Nonpublication Request  
Self addressed postcard  
A check in the amount of \$375.00

is being deposited with the United States Postal Service "Express Mail Post Office to Addressee" service under 37 CFR § 1.10 on the date indicated above and is addressed to:

Mail Stop Patent Application  
Commissioner for Patents  
P.O. Box 1450  
Alexandria, VA 22313-1450

Dated: 8-25-03

  
ANNEROSE BEECH



**PATENT APPLICATION FEE DETERMINATION RECORD**  
Effective January 1, 2003

Application or Docket Number

**CLAIMS AS FILED - PART I**

	(Column 1)	(Column 2)
TOTAL CLAIMS	5	
FOR	NUMBER FILED	NUMBER EXTRA
TOTAL CHARGEABLE CLAIMS	5 minus 20=	* 15
INDEPENDENT CLAIMS	3 minus 3 =	* 0
MULTIPLE DEPENDENT CLAIM PRESENT <input type="checkbox"/>		

\* If the difference in column 1 is less than zero, enter "0" in column 2

**SMALL ENTITY TYPE**  OR

**OTHER THAN SMALL ENTITY**

RATE	FEE
BASIC FEE	375.00
X\$ 9=	
X42=	
+140=	
<b>TOTAL</b>	<b>315</b>

RATE	FEE
BASIC FEE	750.00
X\$18=	
X84=	
+280=	
<b>TOTAL</b>	

**CLAIMS AS AMENDED - PART II**

	(Column 1)	(Column 2)	(Column 3)
<b>AMENDMENT A</b>	CLAIMS REMAINING AFTER AMENDMENT	HIGHEST NUMBER PREVIOUSLY PAID FOR	PRESENT EXTRA
	Total	* Minus	** =
	Independent	* Minus	*** =
FIRST PRESENTATION OF MULTIPLE DEPENDENT CLAIM <input type="checkbox"/>			

**SMALL ENTITY** OR

**OTHER THAN SMALL ENTITY**

RATE	ADDITIONAL FEE
X\$ 9=	
X42=	
+140=	
<b>TOTAL ADDIT. FEE</b>	

RATE	ADDITIONAL FEE
X\$18=	
X84=	
+280=	
<b>TOTAL ADDIT. FEE</b>	

	(Column 1)	(Column 2)	(Column 3)
<b>AMENDMENT B</b>	CLAIMS REMAINING AFTER AMENDMENT	HIGHEST NUMBER PREVIOUSLY PAID FOR	PRESENT EXTRA
	Total	* Minus	** =
	Independent	* Minus	*** =
FIRST PRESENTATION OF MULTIPLE DEPENDENT CLAIM <input type="checkbox"/>			

RATE	ADDITIONAL FEE
X\$ 9=	
X42=	
+140=	
<b>TOTAL ADDIT. FEE</b>	

RATE	ADDITIONAL FEE
X\$18=	
X84=	
+280=	
<b>TOTAL ADDIT. FEE</b>	

	(Column 1)	(Column 2)	(Column 3)
<b>AMENDMENT C</b>	CLAIMS REMAINING AFTER AMENDMENT	HIGHEST NUMBER PREVIOUSLY PAID FOR	PRESENT EXTRA
	Total	* Minus	** =
	Independent	* Minus	*** =
FIRST PRESENTATION OF MULTIPLE DEPENDENT CLAIM <input type="checkbox"/>			

RATE	ADDITIONAL FEE
X\$ 9=	
X42=	
+140=	
<b>TOTAL ADDIT. FEE</b>	

RATE	ADDITIONAL FEE
X\$18=	
X84=	
+280=	
<b>TOTAL ADDIT. FEE</b>	

\* If the entry in column 1 is less than the entry in column 2, write "0" in column 3.

\*\* If the "Highest Number Previously Paid For" IN THIS SPACE is less than 20, enter "20."

\*\*\* If the "Highest Number Previously Paid For" IN THIS SPACE is less than 3, enter "3."

The "Highest Number Previously Paid For" (Total or Independent) is the highest number found in the appropriate box in column 1.

PATENT APPLICATION SERIAL NO. \_\_\_\_\_

U.S. DEPARTMENT OF COMMERCE  
PATENT AND TRADEMARK OFFICE  
FEE RECORD SHEET

08/28/2003 DTESSEM1 00000077 10648012  
01 FC:2001 375.00 OP

PTO-1556  
(5/87)



10-27-04

IFW

Law Offices of  
**DENNIS W. BEECH**

Landmark Building - Newland Center  
19900 Beach Blvd., Suite C-2  
Huntington Beach, CA 92648  
BUS: (714) 378-0212  
FAX: (714) 378-0262

Palmdale/Lancaster: (661) 273-0503  
Temecula/Murrieta: (909) 986-4624  
Brea/Ontario: (909) 986-4624  
Bakersfield: (661) 821-6911  
Fax: (714) 378-0262

**RESPOND TO: HUNTINGTON BEACH**

EXPRESS MAIL

EV482347413US

October 25, 2004

Mail Stop NON-FEE AMENDMENT  
Commissioner for Patents  
P.O. Box 1450  
Alexandria, VA 22313-1450

Serial Number: 10/648,012  
Applicant: C. Earl Woolfork  
Filing Date: 08/26/2003  
Title: WIRELESS DIGITAL AUDIO SYSTEM  
TC/AU: 2644  
Examiner: Graham, Andrew R.

**PRELIMINARY AMENDMENT**

TO THE COMMISSIONER FOR PATENTS:

The following preliminary amendment is submitted for US Patent Application No. 10/648,012 filed on 08-26-2003.

Applicant respectfully submits the following amendments to the application. Applicant believes this amendment is supported by the original disclosure and that no new matter is added by this amendment.

**AMENDMENTS**

**Amendments to the Specification** begin on page 3 of this paper.

**Amendments to the Claims** are reflected in the listing of claims that begins on page 9 of this paper.

**Remarks/Arguments** begin on page 13 of this paper.

## **AMENDMENTS TO THE SPECIFICATION**

In the Abstract of the Disclosure: (Place a replacement or new abstract on a separate sheet)

**[0021]** The fuzzy audio wireless music system utilizes a battery powered **BLUETOOTH compliant** transmitter to transmit a coded digital **BLUETOOTH communication** signal from an existing non-BLUETOOTH analog headphone jack of a music audio player device or source to a battery powered **BLUETOOTH compliant** headphone receiver without the use of wires. A battery powered digital **BLUETOOTH compliant** transmitter may include a headphone plug in communication with a standard analog headphone jack on a audio source, such as, laptop and desktop computers, portable compact disc players, portable MP3 players, portable cassette players,....,etc. The battery powered **BLUETOOTH compliant** transmitter adds a unique user code as defined in the BLUETOOTH standard and transmits it to the battery powered **BLUETOOTH compliant** receiver headphones where a fuzzy logic detector detection system may be used to enhance decoding performance. ~~decodes only the unique user code to~~ **The BLUETOOTH communication FAWM system will** allow private listening without interference from other users, and without the inconvenience of wires.

In the Specifications:

Please replace the paragraphs and the beginning of the specification with the following rewritten paragraphs and beginning:

### **FUZZY AUDIO WIRELESS MUSIC SYSTEM**

This is a continuation-in-part of application Serial No. ~~40/027,739~~ 10/027,391 which patent application is pending.

### **BACKGROUND OF THE INVENTION**

**[0001]** This invention relates to music audio player devices and more particularly to systems that include headphone listening devices. The new audio music system uses an existing device non-BLUETOOTH headphone jack (i.e., this is the standard analog headphone jack that connects to wired headphones) of a music audio player (i.e., portable CD player, portable cassette player,

~~portable A.M./F.M. radio, laptop/desktop computer, portable MP3 player, and the like) to connect a battery powered BLUETOOTH compliant transmitter for digital wireless transmission of a BLUETOOTH communication signal to a set of battery powered BLUETOOTH compliant receiver headphones. BLUETOOTH is a worldwide wireless standard. Detailed Information regarding the standard is available on the web site www.bluetooth.com.~~

**[0002]** Use of music audio headphones with music audio player devices such as ~~radio, tape players, CD players, computers, television audio portable CD players, portable cassette players, portable A.M./F.M. radios, laptop/desktop computer, portable MP3 players and the like,~~ have been in use for many years. These systems incorporate an audio source having a analog non-BLUETOOTH headphone jack to which headphones may be connected by wire ~~and connector~~ .

**[0003]** There are also known ~~non-portable~~ wireless headphones that may receive ~~A.M. and F.M. radio infrared (IR) transmissions. However, these systems operate with a narrow beam width that requires a point-and-shoot style for reception. these systems~~ They do not allow use of a simple plug in (~~i.e., plug in to the existing analog audio headphone jack~~) battery powered BLUETOOTH compliant transmitter for connection to any music audio player device jack, such as; ~~laptop and desktop computers, portable compact disc players, portable MP3 players, portable cassette players and the like, such as the above mentioned music audio player devices for coded digital~~ wireless transmission and reception by BLUETOOTH compliant headphones of audio music for private listening to multiple users occupying the same space without the use of wires. Existing audio systems make use of electrical wire connections between the audio source and the headphones to accomplish private listening to multiple users.

**[0004]** There is a need for a battery powered simple connection system for existing music audio player devices (~~i.e., the previously mentioned music devices~~), to allow coded digital wireless transmission (using a battery powered BLUETOOTH compliant transmitter) to a headphone receiver (using battery powered BLUETOOTH compliant receiver headphones) that accomplishes private listening to multiple users occupying the same space without the use of wires.

#### SUMMARY OF THE INVENTION

**[0005]** The present invention is directed to FAWM (Fuzzy Audio Wireless Music) systems for coded digital transmission, per the BLUETOOTH standard, of an analog audio signal from any music audio player device with a non-BLUETOOTH analog headphone jack to a receiver headphone, which adheres to the BLUETOOTH standard. using Fuzzy logic technology may be

~~utilized by the FAWM system to enhance bit detection. A battery powered digital BLUETOOTH compliant transmitter may include a headphone plug in communication with any of the previously mentioned music audio sources laptop and desktop computers, portable compact disc players, portable MP3 players, portable cassette players and the like. For reception, a battery powered BLUETOOTH compliant headphone receiver may apply fuzzy logic to enhance bit detection. Fuzzy logic detection may be used to enhance bit detection during decoding of the BLUETOOTH communication signal.~~ The FAWM system converts the audio music signal that may be supplied by the source, into a digital signal. This conversion takes place in the small battery powered transmitter that connects to the headphone jack of the source. The transmitter then adds a unique user code and transmits it to the battery powered receiver headphones where the fuzzy logic detector decodes only the unique user code to allow will provide private listening without interference from other users and without the use of wires.

[0006] These and other features, aspects and advantages of the present invention will become better understood with reference to the following drawings, description and claims.

#### BRIEF DESCRIPTION OF THE DRAWINGS

[0007] Figure 1 illustrates a schematic diagram representation of the FAWM system;

Figure 2 illustrates a graph of the high and low bit fuzzy logic if-then part fuzzy set according to an embodiment of the invention.

#### DETAILED DESCRIPTION

[0008] The following detailed description is the best currently contemplated modes for carrying out the invention. The description is not to be taken in a limiting sense, but is made merely for the purpose of illustrating the general principles of the invention.

[0009] Referring to Figure 1, a FAWM system 10 may include a battery powered BLUETOOTH compliant transmitter 20 connected to a portable music audio player (or music audio source) 80. The battery powered BLUETOOTH compliant transmitter 20 that utilizes a CODEC and BLUETOOTH front end may be connected to the music audio source 80 analog non-BLUETOOTH headphone jack 82 using a headphone plug 22. The battery powered BLUETOOTH compliant transmitter 20 may have a transmitting antenna 24 that may be omni-directional for transmitting a

~~coded digital spread spectrum modulated signal, which adheres to the BLUETOOTH standard, to a receiving antenna 52 of a battery powered BLUETOOTH compliant headphone receiver 50. The battery powered BLUETOOTH compliant receiver 50 may have headphone speakers 54 in headphones 55 for listening to the spread spectrum demodulated and decoded digital BLUETOOTH communication signal. During decoding, fuzzy logic detection may be used to increase receiver decoding performance. The FAWM BLUETOOTH compliant transmitter 20 may digitize the audio signal per the BLUETOOTH standard using a CODEC and BLUETOOTH front end. This BLUETOOTH compliant digital signal has a throughput of approximately 1.4 Mbps that may be as low as approximately 1.0 Mbps, which may be determined by the analog to digital A/D converter sampling rate of 44.1kHz multiplied by 16 bit quantization.~~ To reduce the effects of channel noise, the battery powered BLUETOOTH compliant transmitter 20 may use convolutional channel encoding and interleaving. For further noise immunity, spread spectrum modulation, as defined in the BLUETOOTH standard may be is utilized. The battery powered BLUETOOTH compliant transmitter 20 may contain a BLUETOOTH compliant shift register generator, or the like, that may be used to create a unique user code. The unique user code generated is specifically associated with one FAWM user, and it is the only code recognized by the battery powered FAWM BLUETOOTH compliant headphone receiver 50 of that operated by a particular user. The radio frequency (RF) spectrum utilized (as taken from the Industrial, Scientific and Medical (ISM) band), may be approximately 2.4 GHz as defined in the BLUETOOTH standard. And the power radiated by the BLUETOOTH compliant transmitter adheres to the BLUETOOTH standard.

[0010] Referring to Figure 1, the ~~digital spread spectrum modulated BLUETOOTH compliant signal from transmit antenna 24 may be received by receiving antenna 52 and then spread spectrum demodulated per the BLUETOOTH standard, decoded and deinterleaved~~ in the battery powered BLUETOOTH compliant receiver 50 headphones. The battery powered BLUETOOTH compliant receiver 50 may utilize fuzzy logic to optimize the bit detection of the received packet code.

[0011] Each BLUETOOTH compliant receiver headphone 50 user may be able to listen (privately) to high fidelity audio music, using any of the audio devices listed previously, without the use of wires, and without interference from any other BLUETOOTH compliant receiver headphone 50 user. . ~~Because of the fuzzy logic detection technique used in the wireless digital audio system, user separation through code division may be achieved. The fuzzy logic detection technique that may be used in the FAWM could provide greater user separation through optimizing code division in the BLUETOOTH compliant headphone receiver.~~

[0012] The battery powered BLUETOOTH compliant transmitter 20 sends the audio music



information to the battery powered BLUETOOTH compliant receiver 50 in digital packet format as defined in the BLUETOOTH standard. These packets may flow to create a digital bit stream rate of less than or equal to 1.0 Mbps as defined in the BLUETOOTH standard.

[0013] The user code bits in each packet may also be received and detected by a fuzzy logic detection system (as an option) in the headset receiver 50 to provide additional decoding performance. For each consecutive packet received, the fuzzy logic detection system may compute a conditional density with respect to the context and fuzziness of the user packet code vector, i.e., the received user code bits in each packet. The fuzzy logic detector detection system ~~is the key component to the~~ may enable the battery powered FAWM BLUETOOTH compliant system 10. ~~Because the fuzzy logic detector enables the battery powered FAWM receiver 50 to enhance the bit detection accuracy of the~~ packet code in the presence of noise, which may include other FAWM users. Fuzziness may describe the ambiguity of the high bit (1)/low bit (0 or -1) bit event in the received code within the packet. ~~Note that the~~ The fuzzy logic detection system detector may measure the degree to which a high/low bit occurs in the user packet code vector, which produces a low probability of bit error in the presence of noise. The fuzzy logic detection system may use a set of if-then rules to map the code bit inputs to validation outputs. These rules may be developed as if-then statements.

[0014] The fuzzy logic detector detection system in the battery powered BLUETOOTH compliant headphone receiver 50 utilizes the if-then fuzzy set to map the received user code bits into two values; a low (0 or -1) and a high (1). Thus, as the user code bits are received, the "if" rules map the signal bit energy to the fuzzy set low value to some degree and to the fuzzy set high value to some degree. See Figure 2. ~~Due to additive noise each user code bit (bit energy x) may have some membership to a low and high as represented in Figure 2. Therefore, the if-part fuzzy set may determine if each bit in the user code, for every received packet, has a greater membership to a high bit representation or a low bit representation. The more a user code bit energy, x fits into the high or low representation, the closer its subsethood, i.e., a measure of the degree to which a set may be a subset of another set, may be to one. Note that~~ Figure 2 shows that -1 equals the maximum low bit energy representation and 1 equals the maximum high bit energy representation ~~to illustrate that this design may utilize Manchester encoding/decoding schemes. Due to additive noise, the code bit energy may have some membership to low and high as represented in Figure 2. The if-part fuzzy set may determine if each bit in the code, for every received packet, has a greater membership to a high bit representation or a low bit representation. The more a user code bit energy~~ fits into the high or low representation, the closer its subsethood,

i.e., a measure of the degree to which a set may be a subset of another set, may be to one.

[0015] The received user code input bit in each packet may be:

$x(i)$ , where  $i = 1, 2, \dots, n$  is the set of all bits that make up the user code vector.

$X(c)$ , where  $c = 1, 2, \dots, m$  represents each user assigned a unique user code.

So user  $X(1)$  has bit code  $[x(1) x(2) \dots x(n)]$  and user  $X(m)$  has bit code  $[x(1) x(2) \dots x(n)]$  which is different from user  $X(1)$ .

[0016] Each  $x$  in  $X$  may activate a fuzzy "if" rule. The if-part sets may be conditional densities, so the fuzzy "if" rule activates to the degree  $p[x(i)|X(c)] p[X(c)]$ , which is the probability of the user code bits  $x$  given the user vector  $X$  multiplied by the probability of  $X$ .

[0017] The then-part fuzzy rule set may be indirectly dependent on the input bits  $x$  in  $X$ . The then-part set may be a weighted sum equal to  $p[x(i)] p[y|x(i)]$ ,  $i = 1, 2, \dots, n$ .

[0018] Which is the probability of the user bit vector  $x$  multiplied by the probability of  $y$  given the user bit vector  $x$ . Where  $y$  may be a number representation to define the correct user headset battery powered receiver 50 given the input bit set  $x(i)$ ,  $i = 1, 2, \dots, n$ .

[0019] The if-then rule parts that make up the fuzzy logic detector detection system must be followed by a defuzzifying operation. This operation reduces the output mentioned fuzzy set to a bit energy representation (i.e., -1 or 1) single number that determines if the correct that is received user code bits within by the transmitted BLUETOOTH standard packet. have been detected. The defuzzifying operation may be implemented with the modal method, i.e., calculation of the value that has the highest membership in the fuzzy set. With the modal method a strategy of clarity may be applied in the event that some user code energy bit values have equally high membership. The clarity of a fuzzy set may be considered by weighting the conditional densities discussed previously. The weighting determines relative fuzziness of the user code energy bit ( $x$ ) that gives a measure of the uncertainty of the unique user code vector. As a result, the fuzzy logic detector used in the battery powered headset receiver 50 greatly reduces the unique user code bit error probability. The fuzzy logic detection system may be used in the battery powered BLUETOOTH compliant headset receiver 50 to enhance overall FAWM system 10 decoding performance. The fuzzy logic detector technique, combined with convolutional error detection and correction techniques, may enable the FAWM system 10 to operate in most any environment.

[0020] While the invention has been particularly shown and described with respect to the illustrated and preferred embodiments thereof, it will be understood by those skilled in the art that the foregoing and other changes in form and details may be made therein without departing from the spirit and scope of the invention.

## **AMENDMENTS TO THE CLAIMS**

This listing of claims will replace all prior versions, and listings, of claims in the application:

### **Listing of Claims:**

1. (currently amended): A fuzzy audio wireless music system for ~~wireless transmission of a signal from~~ BLUETOOTH communication of an audio music signal from the non-BLUETOOTH analog headphone jack connected to a battery powered BLUETOOTH compliant transmitter and received by a battery powered BLUETOOTH compliant source to a battery powered headphone receiver comprising:

a NON-BLUETOOTH compliant analog headphone jack from an audio music source in communication with ~~a connectable~~ said battery powered BLUETOOTH compliant transmitter; said connectable battery powered BLUETOOTH compliant transmitter converts an analog audio music signal from said existing non-BLUETOOTH analog headphone jack to a BLUETOOTH compliant contains an ~~A/D~~ converter wherein ~~said A/D~~ converter converts an analog music audio signal to a digital signal using a CODEC and a BLUETOOTH front end at a signal rate of approximately 1.4 Mbps as defined in the BLUETOOTH standard;

~~said A/D~~ converter CODEC in communication with a shift register generator that is BLUETOOTH compliant to create a unique user code and a convolutional encoder ~~and an interleaver~~ ;

said interleaver shift register generator in communication with a spread spectrum modulator that is BLUETOOTH compliant;

said BLUETOOTH compliant spread spectrum modulator in communication with a transmit antenna for ~~wireless~~ BLUETOOTH compliant transmission of a coded ~~digital signal~~ BLUETOOTH compliant packet to a receiving antenna at a radio frequency of approximately 2.4 GHz as defined in the BLUETOOTH standard;

said receiving antenna in communication with a spread spectrum demodulator that is BLUETOOTH compliant and a convolutional ~~deinterleaver and a~~ decoder; and

said decoder BLUETOOTH compliant spread spectrum demodulator in communication with a fuzzy logic detector detection system for additional decoding performance.

2. (currently amended): The fuzzy audio wireless music system as in claim 1 wherein said battery powered BLUETOOTH compliant headphone receiver having said fuzzy logic detector detection system with a detection method, comprising the steps of:

- a) receiving a user BLUETOOTH compliant packet code bits having:  
 $x(i)$  where  $i = 1, 2, \dots, n$  is the set of all bits that make up the packet user code vector;  
 $X(c)$ , where  $c = 1, 2, \dots, m$  represents each user assigned unique user code;  
wherein user  $X(1)$  has bit code  $[x(1) x(2) \dots X(n)]$  and user  $X(m)$  has bit code  $[x(1) x(2) \dots x(n)]$  which is different from  $X(1)$ ;
- b) activating a fuzzy logic if rule for each bit energy in the packet code based on each  $x$  in  $X$  wherein the if part sets are conditional densities to activate the if rule to the degree  $p[x(i)|X(c)] p[X(c)]$ ;
- c) activating a fuzzy then rule indirectly dependent on each  $x$  in  $X$  wherein the then part sets are a weighted sum equal to  $p[x(i)]p[y|x(i)]$ ,  $i = 1, 2, \dots, n$  received bit energy; and
- d) performing a defuzzifying fuzzy logic operation to relate the bit energy to one of a digital one(1) and digital zero(0) bit representation. of modal type.

3. (currently amended): A battery powered BLUETOOTH compliant headphone receiver possibly having a an additive fuzzy logic detector detection method, comprising the steps of:

- a) receiving a user BLUETOOTH compliant packet code bits having:  
 $x(i)$  where  $i = 1, 2, \dots, n$  is the set of all bits that make up the packet user code vector;  
 $X(c)$ , where  $c = 1, 2, \dots, m$  represents each user assigned unique user code;  
wherein user  $X(1)$  has bit code  $[x(1) x(2) \dots X(n)]$  and user  $X(m)$  has bit code  $[x(1) x(2) \dots x(n)]$  which is different from  $X(1)$ ;
- b) activating a fuzzy logic if rule for each bit energy in the packet code  $x$  in  $X$  wherein the if part sets are conditional densities to activate the if rule to the degree  $p[x(i)|X(c)] p[X(c)]$ ;
- c) activating a fuzzy then rule indirectly dependent on each  $x$  in  $X$  wherein the

then part sets are a weighted sum equal to  $p[x(i)]p[y|x(i)]$ ,  $i = 1, 2, \dots, n$  received bit energy; and  
d) performing a defuzzifying fuzzy logic operation to relate the bit energy to one of a digital one(1) and digital zero(0) bit representation. operation of modal type.

4. (currently amended): A method for battery powered digital wireless **BLUETOOTH** communication transmission and reception of high fidelity audio music between a battery operated **BLUETOOTH** compliant transmitter and a battery operated **BLUETOOTH** compliant receiver headphone comprising the step of:

connecting the plug attached to said battery operated **BLUETOOTH** compliant transmitter to a the existing non-BLUETOOTH compliant analog headphone jack of an audio music source;

converting an a music audio signal to a digital **BLUETOOTH** communication signal using an A/D converter having a sampling rate of approximately 44.1 kHz multiplied by 16 bit quantization to produce a signal rate of approximately 1.4 Mbps a CODEC and a BLUETOOTH front end;

encoding the digital **BLUETOOTH** communication signal using a convolutional **BLUETOOTH** standard convolutional encoding and interleaving method;

creating a **BLUETOOTH** standard spread spectrum signal using a shift register generator to modulate a unique user code that adheres to the BLUETOOTH standard;

transmitting said **BLUETOOTH** standard spread spectrum signal at a radio frequency of approximately 2.4 GHz at a power level that adheres to the **ISM BLUETOOTH** standard for reception at a distance of up to ~~10~~ less than approximately ~~30~~ feet from said battery operated **BLUETOOTH** compliant transmitter;

receiving said **BLUETOOTH** compliant spread spectrum signal at said battery operated **BLUETOOTH** compliant receiver headphones;

demodulating said **BLUETOOTH** compliant spread spectrum signal; ~~and optimal bit detecting of said unique user code using fuzzy logic technology~~;

convolutional decoding and deinterleaving to receive said digital signal; decoding of said BLUETOOTH communication signal as defined in the BLUETOOTH standard, with an option to apply fuzzy logic detection system to enhance bit detection performance;

converting said digital **BLUETOOTH** communication signal back to said analog music audio signal; and

communication said analog music audio signal to a headphone speaker within the

BLUETOOTH compliant headphone receiver.

5. (currently amended): The ~~battery-powered-receiver-headphone method~~ as in claim 4 wherein said battery operated BLUETOOTH compliant receiver having a fuzzy logic detector method comprising the steps of:

a) receiving ~~a user~~ BLUETOOTH compliant packet code bits having:

~~$x(i)$  where  $i = 1, 2, \dots, n$  is the set of all bits that make up the packet user code vector;~~

~~$X(c)$ , where  $c = 1, 2, \dots, m$  represents each user assigned unique user code; wherein user  $X(1)$  has bit code  $[x(1) x(2) \dots X(n)]$  and user  $X(m)$  has bit code  $[x(1) x(2) \dots x(n)]$  which is different from  $X(1)$ ;~~

b) ~~activating a fuzzy logic if rule for each bit energy in the packet code based on each  $x$  in  $X$  wherein the if part sets are conditional densities to activate the if rule to the degree  $p[x(i)|X(c)] p[X(c)]$ ;~~

c) ~~activating a fuzzy then rule indirectly dependent on each  $x$  in  $X$  wherein the then part sets are a weighted sum equal to  $p[x(i)]p[y|x(i)]$ ,  $i = 1, 2, \dots, n$  received bit energy; and~~

d) ~~performing a defuzzifying fuzzy logic operation to relate the bit energy to one of a digital one(1) and digital zero(0) bit representation. operation of modal type.~~

## **REMARKS/ARGUMENTS**

The applicant has provided the following analysis concerning non-introduction of new matter for this preliminary amendment.

"A Special Interest Group (SIG) was formed to create an industry standard for short range low power radio frequency (RF) connectivity to make free use of intellectual property in a specification. The specification is called Bluetooth. The SIG determined a short range low power RF protocol for personal wireless connectivity technologies that allow personal devices to communicate. The Bluetooth wireless technology serves as a replacement of the interconnecting cables between personal electronic devices. Because the FAWM design replaces the interconnecting cable between a portable audio music device and a pair of headphones, it was necessary to follow the Bluetooth specification to adhere to the RF, low power wireless protocol.

In the initial patent application and the CIP the Bluetooth protocol was described, but the name (Bluetooth) was not called out. The key Bluetooth specifications are as follows: The (1) carrier frequency of approximately 2.4 GHz is in the ISM (Industrial, Scientific, & Medical) band, and the (2) data rate is approximately 1 Mbps. The (3) transmit power is not greater than 100 mW (milliwatts), and has a (4) operating range up to 30 ft (or 10 m). To correct errors that may occur during packet transmission, (5) convolutional encoding is used. Finally, (6) spread spectrum technology is used for maximum immunity to interference.

Each of the Bluetooth specifications listed has been included in the initial patent application and the CIP".

No additional fee for claims is seen to be required.

If you have any questions do not hesitate to contact me.

Very truly yours,

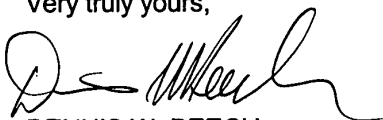

DENNIS W. BEECH  
Reg. No.: 35,443

DWB/ab



IN THE UNITED STATES PATENT AND TRADEMARK OFFICE

In regards to application of:

Serial Number: 10/648,012  
Applicant: C. Earl Woolfork  
Filing Date: 08/26/2003  
Title: WIRELESS DIGITAL AUDIO SYSTEM  
TC/AU: 2644  
Examiner: Graham, Andrew R.

Mail Stop Non-Fee Amendment  
Commissioner for Patents  
P.O. Box 1450  
Alexandria, VA 22313-1450

EXPRESS MAIL CERTIFICATE MAILING UNDER 37 CFR § 1.10

"Express Mail" label number: EV 482347413 US

Date of Deposit: October 25, 2004

I hereby certify that the following attached correspondence comprising:

13 Pages of response

is being deposited with the United States Postal Service "Express Mail Post Office to Addressee" service under 37 CFR § 1.10 on the date indicated above and is addressed to:

Mail Stop Non-Fee Amendment  
Commissioner for Patents  
P.O. Box 1450  
Alexandria, VA 22313-1450

Date: 10-25-04

  
ANNEROSE BEECH



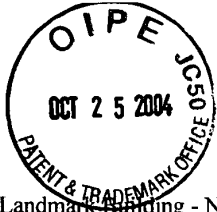

10-27-04

IFW #

Law Offices of  
**DENNIS W. BEECH**

Landmark Building - Newland Center  
19900 Beach Blvd., Suite C-2  
Huntington Beach, CA 92648  
BUS: (714) 378-0212  
FAX: (714) 378-0262

Meridien Building  
1007 West Avenue M-14, Suite C-10  
Palmdale, California 93551  
BUS: (805) 273-0503  
FAX: (714) 378-0262

**RESPOND TO: HUNTINGTON BEACH**

October 25, 2004

Mail Stop Patent Application  
Commissioner for Patents  
**Group Director of Group 2644**  
P.O. Box 1450  
Alexandria, VA 22313-1450

EXPRESS MAIL

EV482346599US

Dear Commissioner:

Enclosed is a petition to make special for:

Serial Number: 10/648,012  
Applicant: C. Earl Woolfork  
Filing Date: 08/26/2003  
Group Art Unit: 2644  
Examiner: Graham, Andrew R.  
For: WIRELESS DIGITAL AUDIO SYSTEM (A.K.A. FAWM)

**PETITION TO MAKE SPECIAL BASED ON AN INFRINGING PRODUCT ACTUALLY ON THE MARKET; 37 CFR 1.102 and MPEP 708.02 II**

Applicant hereby petitions to make this application special because he believes that there is an infringing product and method of use actually on the market.

As a showing of this fact, accompanying this petition is:

A declaration by the applicant.

A fee of \$130.00 is required and is enclosed.

If you have any questions, please do not hesitate to contact me.

Sincerely,

DENNIS W. BEECH  
Reg. No.: 35443

DWB/ab  
Enclosures

10/28/2004 EAREGAY1 00000066 10648012

01 FC:1460

130.00 0P



**DECLARATION IN SUPPORT OF  
PETITION TO MAKE SPECIAL  
BASED ON AN INFRINGING PRODUCT ON THE MARKET**

I, C. Earl Woolfork  
500 Santa Paula Ave.  
Pasadena, CA 91107

am

the inventor

have the following interest or relationship to the above identified invention

\_\_\_\_\_  
\_\_\_\_\_

hereby declare the following:

That there is an infringing product or products actually on the market. One such product is that currently advertised for sale by Bluetake Inc., 525 Parriott Place, City of Industry, CA 91745. The device is currently being marketed and sold as a I-PHONE, Bluetooth Hi-Fi Sports Headphone. The infringing device has specifications and is produced as disclosed and claimed in my currently pending patent application.

A rigid comparison of the alleged infringing product and method of use with the claims of the application has been made, and that, in my opinion, some of the claims are unquestionably infringed.

**PROOF OF INFRINGEMENT**

**FUNCTIONALITY:**

**FAWM**

A transmitter plugs into the existing headphone jack to transmit an audio signal, from an audio source such as a portable cassette player, portable CD player, portable MP3 player, laptop or desktop computer and the like for wireless transmission to a headphone speaker receiver. (1FF)

(Reference claim 1 and "BACKGROUND OF THE INVENTION" of both the original patent submittal and CIP.)

A FAWM user is not subjected to interference from any other FAWM users (i.e., in the same

way a wired system would prevent one user from hearing what the other user is listening to). (2FF)  
(Reference "BACKGROUND OF THE INVENTION" of the original patent submittal and CIP.)

#### Bluetake

A transmitter (called a "Audio Dongle") plugs into the audio jack of an audio device such as a portable CD player, portable cassette player, portable MP3 player, laptop or desktop computer to provide wireless transmission to a headphone speaker receiver (Bluetake calls it a "Sports Headphone"). (1FB)

The Bluetake system (called the "i-phono") prevents one user from interfering with any other "i-phono" users. (2FB)

#### SPECIFICATION:

##### FAWM Transmitter/Headphone Receiver

The FAWM radio frequency (RF) utilized is approximately 2.4 GHz. (1SF)  
(Reference "DETAILED DESCRIPTION" of original patent submittal and claim 1 of the CIP.)

The FAWM data rate used is approximately 1.4 Mbps (2SF)  
(Reference claim 1 of the CIP.)

The FAWM modulation technique used is called Spread Spectrum (3SF)  
(Reference "DETAILED DESCRIPTION" of original patent submittal and claim 1 of the CIP.)

The FAWM transmitter and receiver are both battery operated. (4SF)  
(Reference claim 1 of the CIP.)

##### Bluetake Transmitter/ Headphone Receiver

The Bluetake system uses a RF (radio frequency) of 2.4 –2.48 GHz. (1SB)

The data rate for the Bluetake system is 1.0 Mbps (2SB)

The modulation technique used in the Bluetake system is called Spread Spectrum (3SB)

The Bluetake transmitter and receiver are both battery operated. (4SB)

#### SUMMARY:

By observing the previously described functionality and specifications of the Fuzzy Audio Wireless Music (FAWM) system and Bluetake's "i-phono" system it is evident that Bluetake is infringing the US Patent Application No. 10/648,012. By observing the functionality items 1FF (the FAWM system) and 1FB, (the Bluetake system) it is clear that both perform the same function on the same devices. It is especially important to note that both devices are portable and utilize the

standard headphone jack.

Functionality items 2FF (the FAWM system) and 2FB (the Bluetake system) both prevent one user from interfering with another user. Furthermore, both systems operate as well as a wired system, but without the use of wires.

Specification items 1SF (the FAWM system), 1SB (the Bluetake system), 2SF and 2SB show that similar frequency and data rate are utilized.

Specification items 3SF (the FAWM system) and 3SB (the Bluetake system) prove that both systems utilize the spread spectrum modulation technique to provide a unique user code and reduce the probability of interference.

Specification items 4SF and 4SB show that both systems are battery operated to allow portability.

Please note that a wireless protocol exists to successfully design a short-range low power wireless system (i.e., a RF wireless system that operates within a range of 30 feet). A Special Interest Group (SIG) developed the protocol and the SIG called it "BLUETOOTH." The FAWM system adheres to the BLUETOOTH protocol for short-range low power wireless units ([www.bluetooth.com](http://www.bluetooth.com)). This protocol (or standard) is adhered to and described in both the original patent submittal and the CIP although the name BLUETOOTH was omitted. Bluetake's "i-phonon" also adheres to the BLUETOOTH protocol (or standard).

#### SUMMARY INFORMATION REGARDING CLAIM 1 OF THE PATENT APPLICATION:

Claim 1 of the original patent submittal and the CIP specifies the unique method the FAWM utilizes to extract audio music from the existing standard headphone jack of audio music devices, such as portable CD players, portable MP3 players, portable cassette players, laptop and desktop computers, to convert the analog music signal (from the headphone jack) into a coded digital signal and transmit it to a receiver headphone speaker without the use of wires and without interference from other users.

As of the FAWM conception, no other communication system used front end transmitter electronics (i.e., A/D converter/CODEC) to convert the analog music signal (coming from the standard headphone jack of any of the audio music devices listed previously) to a coded digital signal for wireless transmission at a data rate of approximately 1.4 Mbps.

Furthermore, until the FAWM conception, spread spectrum technology was never applied to a communication system (both the transmitter and receiver) to provide a user of any of the above listed audio music devices the ability to hear music privately without the use of wires and without interference from other users. In short, no other individual FAWM user will hear the music of another FAWM user because of the secure wireless link spread spectrum technology provides.

Finally, until the FAWM conception, no other communication system applied an operating frequency of approximately 2.4 GHz (that adheres to the ISM/BLUETOOTH standard) to a system (i.e., the FAWM) that enables an individual to hear audio music with a headphone speaker, from the audio music devices previously listed, without the use of wires and without interference from other users.

All of the items just cited in claim 1 of the original patent submittal and CIP, have been duplicated by "Bluetake's" "i-phono" system. Their "i-phono" system functions the same as the FAWM system that preceded it.

I made a careful and through search of the prior art and have a good knowledge of the prior art. I have more than 20 years of experience in the electrical engineering business. I have over 8 years of experience in signal processing electronic communication products and methods of use. My schooling is B.S.E.E. (currently pursuing M.S.E.E.). Prior to filing the current patent application for wireless digital audio system, I had a search of prior art performed and a search was performed relative to the parent application on which the current CIP application depends. I believe that the current CIP patent application is allowable over the prior art currently in the File Wrapper and overcomes the previous examination rejections.

I hereby declare that all statements made herein of my own knowledge are true and that all statements made on information and belief are believed to be true; and further that these statements were made with the knowledge that willful false statements and the like so made are punishable by fine or imprisonment, or both, under Section 1001 of Title 18 of the United States Code, and that such willful false statements may jeopardize the validity of the application or any patent issued thereon.

Dated: 10/23/04

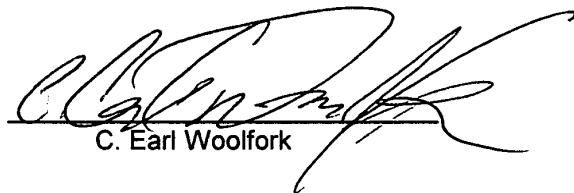
  
C. Earl Woolfork

**PATENT APPLICATION FEE DETERMINATION RECORD**  
Effective January 1, 2003

Application or Docket Number

10/645012

**CLAIMS AS FILED - PART I**

	(Column 1)	(Column 2)
TOTAL CLAIMS	5	
FOR	NUMBER FILED	NUMBER EXTRA
TOTAL CHARGEABLE CLAIMS	5 minus 20=	* 0
INDEPENDENT CLAIMS	3 minus 3 =	* 0
MULTIPLE DEPENDENT CLAIM PRESENT <input type="checkbox"/>		

\* If the difference in column 1 is less than zero, enter "0" in column 2

**CLAIMS AS AMENDED - PART II**

10/25/05

	(Column 1)	(Column 2)	(Column 3)
AMENDMENT A	CLAIMS REMAINING AFTER AMENDMENT	HIGHEST NUMBER PREVIOUSLY PAID FOR	PRESENT EXTRA
	Total	* 5 Minus ** 20	= 0
	Independent	* 3 Minus *** 3	= 0
FIRST PRESENTATION OF MULTIPLE DEPENDENT CLAIM <input type="checkbox"/>			

SMALL ENTITY TYPE  OR OTHER THAN SMALL ENTITY

RATE	FEE	OR	RATE	FEE
BASIC FEE	375.00	OR	BASIC FEE	750.00
X\$ 9=		OR	X\$18=	
X42=		OR	X84=	
+140=		OR	+280=	
TOTAL	315	OR	TOTAL	

SMALL ENTITY OR OTHER THAN SMALL ENTITY

RATE	ADDITIONAL FEE	OR	RATE	ADDITIONAL FEE
X\$ 9=		OR	X\$18=	
X42=		OR	X84=	
+140=		OR	+280=	
TOTAL ADDIT. FEE		OR	TOTAL ADDIT. FEE	

	(Column 1)	(Column 2)	(Column 3)
AMENDMENT B	CLAIMS REMAINING AFTER AMENDMENT	HIGHEST NUMBER PREVIOUSLY PAID FOR	PRESENT EXTRA
	Total	* Minus **	=
	Independent	* Minus ***	=
FIRST PRESENTATION OF MULTIPLE DEPENDENT CLAIM <input type="checkbox"/>			

RATE	ADDITIONAL FEE	OR	RATE	ADDITIONAL FEE
X\$ 9=		OR	X\$18=	
X42=		OR	X84=	
+140=		OR	+280=	
TOTAL ADDIT. FEE		OR	TOTAL ADDIT. FEE	

	(Column 1)	(Column 2)	(Column 3)
AMENDMENT C	CLAIMS REMAINING AFTER AMENDMENT	HIGHEST NUMBER PREVIOUSLY PAID FOR	PRESENT EXTRA
	Total	* Minus **	=
	Independent	* Minus ***	=
FIRST PRESENTATION OF MULTIPLE DEPENDENT CLAIM <input type="checkbox"/>			

RATE	ADDITIONAL FEE	OR	RATE	ADDITIONAL FEE
X\$ 9=		OR	X\$18=	
X42=		OR	X84=	
+140=		OR	+280=	
TOTAL ADDIT. FEE		OR	TOTAL ADDIT. FEE	

\* If the entry in column 1 is less than the entry in column 2, write "0" in column 3.  
 \*\* If the "Highest Number Previously Paid For" IN THIS SPACE is less than 20, enter "20."  
 \*\*\* If the "Highest Number Previously Paid For" IN THIS SPACE is less than 3, enter "3."  
 The "Highest Number Previously Paid For" (Total or Independent) is the highest number found in the appropriate box in column 1.



UNITED STATES PATENT AND TRADEMARK OFFICE

COMMISSIONER FOR PATENTS  
UNITED STATES PATENT AND TRADEMARK OFFICE  
P.O. Box 1450  
ALEXANDRIA, VA 22313-1450  
www.uspto.gov

MAIL

JAN 25 2005

DIRECTOR OFFICE  
TECHNOLOGY CENTER 2600

DENNIS W. BEECH  
19900 BEACH BOULEVARD, SUITE C-2  
HUNTINGTON BEACH CA 92648

In re Application of :  
C. Earl WOOLFORK :  
Application No. 10/648,012 :  
Filed: August 26, 2003 :  
For: **FUZZY AUDIO WIRELESS MUSIC** :  
**SYSTEM** :

DECISION ON PETITION  
TO MAKE SPECIAL

This is a decision on the petition filed October 25, 2004, under 37 CFR §1.102(d) to make the application special and treated as pursuant to MPEP §708.02, section II (Infringement),.

A grantable petition under 37 CFR §1.102(d) and MPEP §708.02, section II (Infringement), must be accompanied by the required fee and a statement alleging:

- (1) that there is an infringing device or product actually on the market or method in use;
- (2) that a rigid comparison of the alleged infringing device, product, or method with the claims of the application has been made, and that, in his or her opinion, some of the claims are unquestionably infringed; and
- (3) that he or she has made or caused to be made a careful and thorough search of the prior art or has a good knowledge of the pertinent prior art. Further, Applicant must provide a copy of each of the references deemed most closely related to the subject matter encompassed by the claims if the references are not already of record.

The petitioner meets all the above-listed requirements. Accordingly, the petition is GRANTED.

The application will retain its special status throughout its entire prosecution, including any appeal to the Board of Patent Appeals and Interferences, subject only to diligent prosecution by the applicant.

The application is being forwarded to the examiner for expedited prosecution.

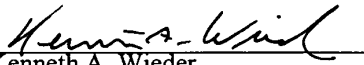
  
Kenneth A. Wieder  
Special Program Examiner  
Technology Center 2600  
Communications



UNITED STATES PATENT AND TRADEMARK OFFICE

fw

UNITED STATES DEPARTMENT OF COMMERCE  
United States Patent and Trademark Office  
Address: COMMISSIONER FOR PATENTS  
P.O. Box 1450  
Alexandria, Virginia 22313-1450  
www.uspto.gov

APPLICATION NO.	FILING DATE	FIRST NAMED INVENTOR	ATTORNEY DOCKET NO.	CONFIRMATION NO.
10/648,012	08/26/2003	C. Earl Woolfork		3337

42794 7590 05/18/2005  
DENNIS W. BEECH (LAW OFFICE OF DENNIS W. BEECH)  
P.O. BOX 519  
MURRIETA, CA 92564-0519

EXAMINER

GRAHAM, ANDREW R

ART UNIT PAPER NUMBER

2644

DATE MAILED: 05/18/2005

Please find below and/or attached an Office communication concerning this application or proceeding.



<b>Office Action Summary</b>	Application No. 10/648,012	Applicant(s) WOOLFORK, C. EARL	
	Examiner Andrew Graham	Art Unit 2644	

-- The MAILING DATE of this communication appears on the cover sheet with the correspondence address --

**Period for Reply**

A SHORTENED STATUTORY PERIOD FOR REPLY IS SET TO EXPIRE 3 MONTH(S) FROM THE MAILING DATE OF THIS COMMUNICATION.

- Extensions of time may be available under the provisions of 37 CFR 1.136(a). In no event, however, may a reply be timely filed after SIX (6) MONTHS from the mailing date of this communication.
- If the period for reply specified above is less than thirty (30) days, a reply within the statutory minimum of thirty (30) days will be considered timely.
- If NO period for reply is specified above, the maximum statutory period will apply and will expire SIX (6) MONTHS from the mailing date of this communication.
- Failure to reply within the set or extended period for reply will, by statute, cause the application to become ABANDONED (35 U.S.C. § 133). Any reply received by the Office later than three months after the mailing date of this communication, even if timely filed, may reduce any earned patent term adjustment. See 37 CFR 1.704(b).

**Status**

- 1)  Responsive to communication(s) filed on 25 October 2004.
- 2a)  This action is **FINAL**.                      2b)  This action is non-final.
- 3)  Since this application is in condition for allowance except for formal matters, prosecution as to the merits is closed in accordance with the practice under *Ex parte Quayle*, 1935 C.D. 11, 453 O.G. 213.

**Disposition of Claims**

- 4)  Claim(s) 1-5 is/are pending in the application.  
4a) Of the above claim(s) \_\_\_\_\_ is/are withdrawn from consideration.
- 5)  Claim(s) \_\_\_\_\_ is/are allowed.
- 6)  Claim(s) 1-5 is/are rejected.
- 7)  Claim(s) \_\_\_\_\_ is/are objected to.
- 8)  Claim(s) \_\_\_\_\_ are subject to restriction and/or election requirement.

**Application Papers**

- 9)  The specification is objected to by the Examiner.
- 10)  The drawing(s) filed on 26 August 2003 is/are: a)  accepted or b)  objected to by the Examiner.  
Applicant may not request that any objection to the drawing(s) be held in abeyance. See 37 CFR 1.85(a).  
Replacement drawing sheet(s) including the correction is required if the drawing(s) is objected to. See 37 CFR 1.121(d).
- 11)  The oath or declaration is objected to by the Examiner. Note the attached Office Action or form PTO-152.

**Priority under 35 U.S.C. § 119**

- 12)  Acknowledgment is made of a claim for foreign priority under 35 U.S.C. § 119(a)-(d) or (f).  
a)  All    b)  Some \*    c)  None of:
1.  Certified copies of the priority documents have been received.
2.  Certified copies of the priority documents have been received in Application No. \_\_\_\_\_.
3.  Copies of the certified copies of the priority documents have been received in this National Stage application from the International Bureau (PCT Rule 17.2(a)).

\* See the attached detailed Office action for a list of the certified copies not received.

**Attachment(s)**

- |  |   |
|--|---|
| 1) <input checked="" type="checkbox"/> Notice of References Cited (PTO-892)  | 4) <input type="checkbox"/> Interview Summary (PTO-413)<br>Paper No(s)/Mail Date. _____ |
| 2) <input type="checkbox"/> Notice of Draftsperson's Patent Drawing Review (PTO-948)                                   | 5) <input type="checkbox"/> Notice of Informal Patent Application (PTO-152)             |
| 3) <input type="checkbox"/> Information Disclosure Statement(s) (PTO-1449 or PTO/SB/08)<br>Paper No(s)/Mail Date _____ | 6) <input type="checkbox"/> Other: _____  |

**DETAILED ACTION**

***Response to Remarks/Amendment***

1. Applicant's arguments filed October 25, 2004 that pertain to the concurrently submitted amendments have been fully considered but they are not persuasive in terms of the non-introduction of new matter.

The remarks state that the Bluetooth protocol was described, but not identified by name (page 13, lines 12-13). The remarks then denote six criterion as 'key Bluetooth specifications' (page 13, lines 13-18). Based on these specifications, which are stated to have been included in the initial patent application and present, continuation-in-part application, the applicant submits that the amendment does not introduce new matter (page 13, lines 2-3 and 19-20).

However, the examiner respectfully submits that the relationship between the applicant's disclosure(s) and the Bluetooth protocol are not mutually inclusive. In other words, properties included in the applicant's specification are paralleled in the properties of the Bluetooth protocol, but the Bluetooth protocol includes other properties that are not addressed by the applicant's specification. As such, to amended the application to state that the transmitter involved a "BLUETOOTH compliant transmitter" (see Claim 1 and paragraph 0008) means that the now-claimed transmitted involves all of the requirements for the transmitter that are defined in the Bluetooth protocol. Certain ones of these requirements for a transmitter were not addressed by the applicant's original or CIP disclosures. As the

Art Unit: 2644

amendment suggests that these certain requirements are included, such an amendment is considered to introduce new matter. For example, the Bluetooth protocol requires that the transmitted initial center frequency be  $\pm 75$  kHz from the ideal center frequency ( $F_c$ ) and has a maximum drift rate of 400 Hz/ $\mu$ s, as is described, for example, on page 23 of Version 1.0 B of the Bluetooth Specification. Such requirements are not addressed by the applicant's initial or CIP disclosures, which causes the Bluetooth compliant transmitter of the present version of the disclosure/claims to incorporate new matter.

Also, the applicant's disclosure states that the transmitter is a differential phase shift key transmitter (page 4, lines 1-4 of the initial disclosure, application number 10/027391; the disclosure originally submitted with the present application does not discuss a shift keying). The Bluetooth standard, however, uses a Gaussian frequency shift keying (GFSK), as is defined on page 21 of the Version 1.0 B specification. Accordingly, the two systems utilize different shift keying schemes, and the system of the applicant appears to not be Bluetooth-based, in light of the disclosure of the initial application. As the GFSK is a requirement of the Bluetooth protocol and the disclosure of the present application (CIP) is at least silent to involved/any shift keying, the transmission scheme of the present application (CIP) at least cannot be described as "Bluetooth communication" because the CIP's initial disclosure does not include the necessary support.

Art Unit: 2644

Furthermore, the general recitation of "Bluetooth" is considered indefinite because it does not delimit a version number of the Bluetooth specification. Accordingly, the presently amended disclosure does not clearly delimit which version(s) of the Bluetooth specification, including future versions that have not been published, certain phrases such as "BLUETOOTH compliant" are intended to refer.

*Specification*

2. The amendment filed 10/25/04 is objected to under 35 U.S.C. 132 because it introduces new matter into the disclosure. 35 U.S.C. 132 states that no amendment shall introduce new matter into the disclosure of the invention. As further discussed in the above paragraph, amended references to the Bluetooth protocol do not have support found in the initial disclosure of this CIP application. Such references, and other recitations of new matter, are required to be cancelled from the amended version of the disclosure, as follows:

- Page 3, lines 3-4, 6, 7, 10, 11-12: "BLUETOOTH compliant", made in references to the transmitter and receiver; as explained above, at least the modulation performed in a BLUETOOTH system is not supported by the original disclosure.
- Page 3, lines 4 and 13-14: "BLUETOOTH communication" made in reference to a transmitted signal and FAWM system; as explained above, at least the modulation performed in a BLUETOOTH system is not supported by the original disclosure

Art Unit: 2644

- Page 3, lines 5 and 25: "non-BLUETOOTH", made in reference to the jack; such a restriction on the nature of the jack is not clearly supported by the original disclosure
- Page 3, line 11: "as defined in the BLUETOOTH standard" imparts properties to the code not supported by the original disclosure
- Page 4, lines 2, 3, 15, 18, 24, and 25: "BLUETOOTH compliant" infers characteristics upon the transmitter, receiver, and other addressed components that were not described in the original disclosure
- Page 4, lines 3: "BLUETOOTH communication" imparts characteristics to the transmission not supported by the original disclosure
- Page 4, lines 4-5: "BLUETOOTH is a worldwide wireless standard. Detailed information regarding the standard is available on the web site [www.bluetooth.com](http://www.bluetooth.com)." includes information not found in the initial disclosure
- Page 4, line 11: "non-portable" imparts information not found in the initial disclosure
- Page 4, line 12: "infrared (IR)" imparts information not found in the initial disclosure, which cited 'radio' transmission
- Page 4, lines 12-13. "these systems operate with narrow beam width that requires a point-and-shoot style for reception" and "They" present information not found in the initial disclosure

Art Unit: 2644

- Page 4, lines 29 and 31 "per the BLUETOOTH standard" and "which adheres to the BLUETOOTH standard", made in reference to the transmission and receiver, conveys a relationship not presented in the initial disclosure
- Page 4, lines 9 and 30: "non-BLUETOOTH", made in reference to the jack
- Page 5, lines 1-2, 5, 24, 25, 27: "BLUETOOTH compliant", made in reference to the transmitter and receiver
- Page 5, lines 6-7: "BLUETOOTH communication" imparts characteristics to the transmission not supported by the original disclosure
- Page 5, lines 25-26: "that utilizes a CODEC and BLUETOOTH front end" is a property of the transmitter not disclosed or supported by the originally filed specification
- Page 5, line 26: "non-BLUETOOTH" conveys characteristics associated with the headphone jack not supported by the originally filed specification
- Page 6, line 1: "which adheres to the BLUETOOTH standard" imparts a characteristic to the modulated signal not supported by the originally filed specification
- Page 6, lines 2, 3, 6, 8, 11, 13, 14, 17, 20, 21, 24, 26, 28, 32, and 33: "BLUETOOTH compliant", as discussed above, is not a characteristic of the transmitter or receiver supported by the original disclosure

Art Unit: 2644

- Page 6, lines 4-5: "BLUETOOTH communication" is not a characteristic of the transmitted signal supported by the original disclosure
- Page 6, lines 7: "per the BLUETOOTH standard using a CODEC and BLUETOOTH front end" is not a type of digitization nor set of components supported for the transmitter of the original disclosure
- Page 6, lines 12-13: "as defined in the BLUETOOTH specification" conveys a set of characteristics to the spread spectrum modulation not supported in the original disclosure
- Page 6, line 14: "or the like", conveys analogous generators that were not clearly considered in the original disclosure as filed
- Page 6, line 19: "as defined in the BLUETOOTH standard" assesses particular characteristics to the 2.4 GHz spectrum usage that are not supported by the original disclosure
- Page 6, line 23: "per the BLUETOOTH specification" conveys a set of characteristics to the spread spectrum demodulation not supported in the original disclosure
- Page 6, line 25: "packet" asserts that the fuzzy logic may be used to increase the bit detection of the overall packet (which comprises the user code, along with other data). The originally filed disclosure only denotes the use of fuzzy logic with the user code. As such, optimizing the packet code

Art Unit: 2644

is considered to suggest enhancing more than just the user code, which is unsubstantiated.

- Page 7, lines 1, 9, 18-19: "BLUETOOTH compliant" as discussed above, is not a characteristic of the transmitter or receiver supported by the original disclosure
- Page 7, lines 2 and 3: "as defined in the BLUETOOTH standard" conveys characteristics of the format and bit stream rate not supported by the original disclosure
- Page 7, line 4: the strikethrough of "user" suggests that code bits in each packet other than those related to the user code may be processed by the fuzzy logic detector, which is not supported by the original disclosure. The same objection applied to "packet code" in line 11, the strikethrough of "user" and addition of "packet" in line 14, the strikethrough of "user" in line 20, and the lack of a "user" qualifier before the word "code" in lines 30 and 31.
- Page 8, line 18 and 27, "BLUETOOTH standard" imparts characteristics to the packet that were fully supported in the original disclosure
- Page 8, line 27, "BLUETOOTH compliant" imparts characteristics to the receiver was not fully supported in the original disclosure

Per MPEP 608.04, the applicant is required to cancel the new matter in the reply to this Office action.



Art Unit: 2644

***Drawings***

3. The drawings are objected to under 37 CFR 1.83(a). The drawings must show every feature of the invention specified in the claims. Therefore, each of the components recited in the claims, such as the codec, Bluetooth front end, shift register generator, encoder, decoder, modulator, demodulator, decoder, fuzzy logic system, as well as the steps of the methods, such as the receiving of a BLUETOOTH compliant packet, activating a fuzzy logic "if" rule, activating a fuzzy logic "then" rule, and performing a defuzzifying operation must be shown in the drawing or the feature(s) canceled from the claim(s). No new matter should be entered.

Corrected drawing sheets in compliance with 37 CFR 1.121(d) are required in reply to the Office action to avoid abandonment of the application. Any amended replacement drawing sheet should include all of the figures appearing on the immediate prior version of the sheet, even if only one figure is being amended. The figure or figure number of an amended drawing should not be labeled as "amended." If a drawing figure is to be canceled, the appropriate figure must be removed from the replacement sheet, and where necessary, the remaining figures must be renumbered and appropriate changes made to the brief description of the several views of the drawings for consistency. Additional replacement sheets may be necessary to show the renumbering of the remaining figures. Each drawing sheet submitted after the filing date of an application must be labeled in the top margin as either "Replacement Sheet" or "New Sheet" pursuant to 37 CFR 1.121(d). If the

Art Unit: 2644

changes are not accepted by the examiner, the applicant will be notified and informed of any required corrective action in the next Office action. The objection to the drawings will not be held in abeyance.

***Claim Rejections - 35 USC § 112 - 1<sup>st</sup> paragraph***

The following is a quotation of the first paragraph of 35 U.S.C. 112:

The specification shall contain a written description of the invention, and of the manner and process of making and using it, in such full, clear, concise, and exact terms as to enable any person skilled in the art to which it pertains, or with which it is most nearly connected, to make and use the same and shall set forth the best mode contemplated by the inventor of carrying out his invention.

4. **Claims 1-5** are rejected under 35 U.S.C. 112, first paragraph, as failing to comply with the written description requirement. The claim(s) contains subject matter which was not described in the specification in such a way as to reasonably convey to one skilled in the relevant art that the inventor(s), at the time the application was filed, had possession of the claimed invention. The grounds upon which the following limitations are considered to involve new matter is discussed in further detail above, in regards to the corresponding matter found in the specification.

**Claim 1** contains the following limitations which incorporate new matter:

Line 2: "BLUETOOTH communication" suggests a form of transmission not supported in the original disclosure

Art Unit: 2644

Lines 2, 6, and 9: "NON BLUETOOTH" imparts restrictions on the jack not provided for in the original disclosure

Lines 3, 4, 7, 8, 10, 14, 17, 18, 19, 20, 23, 24: "BLUETOOTH compliant" imparts requirements on the transmitter, headphone, packet, generator, modulator, transmission, and demodulator not provided for in the original disclosure

Lines 11 and 13: a "CODEC" is not clearly provided for in the original disclosure

Line 11: a "BLUETOOTH front end" is not clearly provided for in the original disclosure

Lines 12 and 21: "as defined in the BLUETOOTH standard" imparts a correlation not clearly denoted in the original disclosure

**Claim 2** contains the following limitations which incorporate new matter:

Line 2: "BLUETOOTH compliant" imparts requirements on the headphone receiver not provided for in the original disclosure

Line 3: "BLUETOOTH compliant packet" imparts requirements upon the packet not supported in the original disclosure

Line 10: "for each bit energy in the packet code" involves executing the logic 'if' on each of the bits in the packet, instead of only the user code; the original disclosure only supports the execution of such a rule on the user code bits (paragraphs 0013-0016 of the original disclosure)

Lines 13-14: "on each received bit energy" involves executing the logic 'then' on each of the bits in the packet, instead of only the

Art Unit: 2644

user code; the original disclosure only supports the execution of such a rule on the user code bits (paragraphs 0017-0018 of the original disclosure)

**Claim 3** contains the following limitations which incorporate new matter:

Line 1: "BLUETOOTH compliant" imparts requirements on the headphone receiver not provided for in the original disclosure

Line 4: "BLUETOOTH compliant packet" imparts requirements upon the packet not supported in the original disclosure

Line 10: "for each bit energy in the packet code" involves executing the logic 'if' on each of the bits in the packet, instead of only the user code; the original disclosure only supports the execution of such a rule on the user code bits (paragraphs 0013-0016 of the original disclosure)

Lines 13-14: "on each received bit energy" involves executing the logic 'then' on each of the bits in the packet, instead of only the user code; the original disclosure only supports the execution of such a rule on the user code bits (paragraphs 0017-0018 of the original disclosure)

**Claim 4** contains the following limitations which incorporate new matter:

Lines 1-2, 8, 12, 25 and 27: "BLUETOOTH communication" suggests a form of transmission not supported in the original disclosure

Line 6: "non BLUETOOTH" imparts restrictions on the jack not provided for in the original disclosure

Art Unit: 2644

Lines 3, 5, 19, 20, 21, 22, and 30: "BLUETOOTH compliant" imparts requirements on the transmitter, receiver, and spread spectrum signal not provided for in the original disclosure

Line 10: a "CODEC" is not clearly provided for in the original disclosure

Lines 10-11: a "BLUETOOTH front end" is not clearly provided for in the original disclosure

Lines 13, 14, 15, 16, 17, and 25: "BLUETOOTH standard", "adheres to the BLUETOOTH standard", and "as defined in the BLUETOOTH standard" imparts a correlation not clearly denoted in the original disclosure

Line 18: "less than approximately 30 feet" imparts a range not clearly denoted in the original disclosure

**Claim 5** contains the following limitations which incorporate new matter:

Line 2: "BLUETOOTH compliant" imparts requirements on the receiver not provided for in the original disclosure

Line 4: "BLUETOOTH compliant packet" imparts requirements upon the packet not supported in the original disclosure

Line 10: "for each bit energy in the packet code" involves executing the logic 'if' on each of the bits in the packet, instead of only the user code; the original disclosure only supports the execution of such a rule on the user code bits (paragraphs 0013-0016 of the original disclosure)

Lines 13-14: "on each received bit energy" involves executing the logic 'then' on each of the bits in the packet, instead of only the

Art Unit: 2644

user code; the original disclosure only supports the execution of such a rule on the user code bits (paragraphs 0017-0018 of the original disclosure)

5. **Claims 4 and 5** are rejected under 35 U.S.C. 112, first paragraph, as failing to comply with the enablement requirement. The claim(s) contains subject matter which was not described in the specification in such a way as to enable one skilled in the art to which it pertains, or with which it is most nearly connected, to make and/or use the invention.

**Claim 4**, lines 25-26 state "with an option to apply fuzzy logic detection system". However, the details of how this system is made "optionally applicable", such as the physical connections or functional basis upon which the system is opted in or out of the processing sequence, are not disclosed nor suggested by the original disclosure.

Claim 4 also recites "BLUETOOTH standard convolutional encoding" and "convolutional decoding of said BLUETOOTH communications signal as defined in the BLUETOOTH standard" in lines 13 and 24-25. The BLUETOOTH standard does not clearly disclose the concept of "convolutional" encoding or decoding, as is conventionally understood by the terminology. Accordingly, until further corrected or clarified, such encoding and decoding per the BLUETOOTH standard is considered not enabled.

Art Unit: 2644

**Claim 5** is rejected due to its respective dependency upon Claim 4.

***Claim Rejections - 35 USC § 112 - 2<sup>nd</sup> paragraph***

The following is a quotation of the second paragraph of 35 U.S.C. 112:

The specification shall conclude with one or more claims particularly pointing out and distinctly claiming the subject matter which the applicant regards as his invention.

6. **Claim 3** is rejected under 35 U.S.C. 112, second paragraph, as being indefinite for failing to particularly point out and distinctly claim the subject matter which applicant regards as the invention.

**Claim 3** states that the receiver "possibly" has an additive fuzzy logic detection system. The phrase "possibly" renders the claim indefinite because it is unclear whether the limitations following the phrase are part of the claimed invention.

***Claim Rejections - 35 USC § 103***

The following is a quotation of 35 U.S.C. 103(a) which forms the basis for all obviousness rejections set forth in this Office action:

(a) A patent may not be obtained though the invention is not identically disclosed or described as set forth in section 102 of this title, if the differences between the subject matter sought to be patented and the prior art are such that the subject matter as a whole would have been obvious at the time the invention was made to a person having ordinary skill in the art to which said subject matter pertains. Patentability shall not be negated by the manner in which the invention was made.

7. **Claims 1-5** are rejected under U.S.C. 103(a) as being unpatentable over Mooney et al (US 20030045235) in view of Altstatt (USPN 5771441) and Benthin et al (USPN 5790595). Hereafter, "Mooney

Art Unit: 2644

et al" will be referred to as "Mooney". "Benthin et al" will be referred to as "Benthin". In this rejection, Mooney makes repeated reference to the BLUETOOTH protocol of communication. To this end, the Specification of the Bluetooth System, Version 1.0 B (hereafter, "Bluetooth Specification") will on occasion be cited to illustrate that certain explicit limitations of the claims are inherently included in Mooney's reference to the BLUETOOTH protocol.

Mooney teaches a dongle for converting the headset jack of a telephone into a wireless communication port for a BLUETOOTH-enabled wireless headset.

Specifically regarding **Claim 1**, Mooney teaches:

A fuzzy audio wireless system for BLUETOOTH communication of an audio signal (system and function of Figure 1; p. 0036)

from the non-BLUETOOTH analog headphone jack ("analog audio jack", 252; p. 0036, 0047) connected to a BLUETOOTH compliant transmitter (100, p.0041,0051)and

received by a BLUETOOTH compliant headphone receiver (504) (p.0048) comprising:

a NON-BLUETOOTH compliant analog headphone jack ("analog audio jack" of conventional telephone that does not have BLUETOOTH installed; p. 0025, 0036) from an audio source (170) in communication (signals received over 252) with said BLUETOOTH compliant transmitter (100) (p.0047);

said BLUETOOTH compliant transmitter (100) converts an analog audio signal (input from 252) from said existing non-BLUETOOTH analog



Art Unit: 2644

headphone jack (connection from 170 to 252) to a BLUETOOTH compliant digital signal using a CODEC (204) and a BLUETOOTH front end (202) (p. 0044,0048,0053,0059)

at a signal rate of approximately 1.4 Mbps as defined in the BLUETOOTH standard (inherent, enabling BLUETOOTH communication involves adhering to BLUETOOTH required bit rate, 1 Mbps, as denoted on page 44 of BLUETOOTH specification);

said CODEC (204) in communication with a shift register generator (LFSR, part of BLUETOOTH front end 202) that is BLUETOOTH compliant to create a unique user code (BLUETOOTH device address BD\_ADDR) (inherently part of BLUETOOTH front end 202; see pages 143-147 of BLUETOOTH specification regarding use of LFSR in generating BD\_ADDR)

said shift register generator (LFSR involved in generating BD\_ADDR) in communication with a spread spectrum modulator (circuitry of 202 that generates and applies hopping sequence; hopping sequence based on BD\_ADDR of master, see page 43 of BLUETOOTH specification) that is BLUETOOTH compliant (inherent, part of BLUETOOTH front end 202);

said BLUETOOTH compliant spread spectrum modulator (inherent, circuitry that implements determined hop frequency, performs FM modulation in 202, see page 41 of BLUETOOTH specification) in communication with a transmit antenna (antenna, Figure 2 of Mooney) for BLUETOOTH compliant transmission of a coded BLUETOOTH compliant packet (output of 202, establishment of communication between 100 and

Art Unit: 2644

504, p. 0039; see also page 41 of BLUETOOTH specification for modulation of packets)

to a receiving antenna (antenna on 504, Figure 1) at a radio frequency of approximately 2.4 GHz as defined in the BLUETOOTH standard (inherent, BLUETOOTH communication in system of Mooney, see page 43 of BLUETOOTH specification),

said receiving antenna (on 504, Figure 1) in communication with a spread spectrum demodulator (inherently part of 504, frequency hop transceiver involves FM modulation, and thus, inherently demodulation from the hop frequency and GFSK based frequency deviations; see pages 41,44 of BLUETOOTH specification) that is BLUETOOTH compliant (inherently compliant as it receives BLUETOOTH communication signal)

However, Mooney does not clearly specify:

- that the BLUETOOTH compliant transmitter is battery powered
- that the BLUETOOTH compliant headphone receiver is battery powered
- that the analog audio signal is an analog audio music signal

Altstatt teaches an audio dongle for an portable audio device that utilizes a RF connection to interface a pair of wireless headphones.

Specifically regarding Claim 1, Altstatt teaches:

the BLUETOOTH compliant transmitter is battery powered (col. 4, lines 36-39)

the BLUETOOTH compliant headphone receiver is battery powered (inherent, headphones are wireless, col. 4, lines 48-67, but

Art Unit: 2644

require power for receiver circuitry, col. 8, lines 51-67; col. 9, lines 1-19)

the analog audio signal is an analog audio music signal (input source 10 comprises radio, cassette player, CD player, col. 4, lines 29-34)

To one of ordinary skill in the art at the time the invention was made, it would have been obvious to modify the system of Mooney to utilize battery powered components and connect to audio sources, as is taught by Altstatt. The motivation behind the use of battery components would have been the elimination of wires or external connections for the provision of power to the transmitter, source, and headset. The connection to audio sources, such as a portable radio or cassette player, would have enabled the wireless headset of Mooney to receive user-selected music, such as that prerecorded on a medium, for enjoyment during exercising, rollerblading, and other physical activities that involve a great deal of arm motion.

However, as part of this error correction encoding and decoding, Mooney in view of Altstatt does not specify:

- the use of a convolutional encoder in communication with the CODEC
- the use of convolutional decoder in communication with the receiving antenna
- a fuzzy logic detection system for additional decoding performance in communication with the received, demodulated signal from the spread spectrum demodulator

Art Unit: 2644

Benthin teaches a method for reliably obtaining bit specific information using soft data bits.

Specifically regarding Claim 1, Benthin teaches:

the use of a convolutional encoder (Viterbi decoding may be used, per col. 5, lines 34-39, which inherently involves Viterbi encoding of data groups in the channel; col. 1, lines 10-18; col. 5, lines 60-65) in communication with the CODEC (encoder as part of front end 202, in communication with 204 in system of Mooney)

the use of convolutional decoder (Viterbi decoder, col. 5, lines 34-39 in view of decoding in receive path of Mooney, as illustrated in Figure 8.4 of BLUETOOTH specification) in communication with the receiving antenna (10) (col. 1, lines 61-63).

a fuzzy logic detection system (implemented in 12, determines soft data bits) (Figure 1, function of Figure 2) for additional decoding performance in communication with the received, demodulated signal (output of 11) from the spread spectrum demodulator (11) (col. 2, lines 6-31 col. 5, lines 10-25)

To one of ordinary skill in the art at the time the invention was made, it would have been obvious to implement the convolutional encoding scheme as well as the soft decision relevant components of Benthin as part of the encoding and signal reception parts of the system of Mooney in view of Altstatt. The motivation behind such a modification would have been that convolutional encoding is well known

Art Unit: 2644

in the art to perform well under high error conditions and is often inexpensive to implement. The soft bit determining circuitry would have improved the reliability of the decision relating to the hard data bit equivalents of the received information, as is taught by Benthin.

Regarding **Claim 2**, Mooney in view of Altstatt and Benthin particularly discloses:

said battery powered BLUETOOTH compliant headphone receiver (504 of Mooney, in view of 14 of Alstatt) having said fuzzy logic detection system (12 of Benthin) with a detection method, comprising the steps of:

a) receiving (step 1) a BLUETOOTH compliant packet code bits having all bits that make up the packet code (col. 1, lines 61-67; col. 2, lines 1-17);

b) activating a fuzzy logic if rule for each bit energy in the packet code (aspect of step 2, determination of probability value for each symbol, each symbol represents a group of bits, which involves received energy; col. 2, lines 18-65; col. 3, lines 1-16 of Benthin)

c) activating a fuzzy then rule indirectly dependent on each received energy bit (determining of a posteriori probability, step 3, col. 3, lines 17-65 of Benthin); and

d) performing a defuzzifying fuzzy logic operation to relate the bit energy to one of a digital one (1) and digital zero(0) bit representation (col. 5, lines 22-49 of Benthin).

Art Unit: 2644

Regarding **Claim 3**, please refer above to the rejection of the similar limitations of Claim 2, noting that the derivation of a posteriori probabilities in Benthin involve summation, which equates to "additive".

Regarding **Claim 4**, Mooney in view of Alstatt and Benthin teaches:

A method for battery powered wireless BLUETOOTH communication transmission and reception of high fidelity audio music (from 10 of Alstatt) between a battery operated BLUETOOTH compliant transmitter (14 of Altstatt in view of 100 of Mooney) and a battery operated BLUETOOTH compliant receiver headphone (504 of Mooney in view of 16 of Altstatt) (para. 0027 of Mooney, in view of col. 4, lines 29-53 of Altstatt) comprising the step of:

connecting the plug (18 of Alstatt) attached to said battery operated BLUETOOTH compliant transmitter (14 of Altstatt in view of communication scheme of Mooney) to the existing non-BLUETOOTH compliant analog headphone jack (12) of an audio music source (10, of Altstatt)(col. 4, lines 36-39);

converting an a music audio signal (from 10 of Altstatt) to a BLUETOOTH communication signal using a CODEC (204) and A BLUETOOTH front end (202)(para. 0047-0048, Figure 2);

encoding the BLUETOOTH communication signal using BLUETOOTH standard convolutional encoding creating a BLUETOOTH standard spread spectrum signal using a shift register generator to modulate a unique user code that adheres to the BLUETOOTH standard (inherent, operation of BLUETOOTH front end; para. 0048,0051);

Art Unit: 2644

transmitting said BLUETOOTH standard spread spectrum signal at a radio frequency of approximately 2.4 GHZ at a power level that adheres to the BLUETOOTH standard (inherent, defined in BLUETOOTH specification for BLUETOOTH front end 202 of Mooney)

for reception at a distance less than approximately 30 feet from said battery operated BLUETOOTH compliant transmitter (Altstatt requires 3 ft, col. 6, lines 41-46);

receiving said BLUETOOTH compliant spread spectrum signal at said battery operated BLUETOOTH compliant receiver headphones (inherent, reception of BLUETOOTH signal, para. 0017,0021 of Mooney);

demodulating said BLUETOOTH compliant spread spectrum signal (inherent, part of BLUETOOTH communication implemented by Mooney)

convolutional decoding of said BLUETOOTH communication signal as defined in the BLUETOOTH standard (inherent, part of BLUETOOTH communication of 504 implemented by Mooney, in view of Vitterbi decoding of Benthin, col. 5, lines 34-39)

with an option to apply fuzzy logic detection system to enhance bit detection performance (processing of BLUETOOTH communication signal payload is optional, depending on packet type and enabled mode, as defined by BLUETOOTH specification, part of BLUETOOTH communication implemented by Mooney, page 86 of BLUETOOTH spec; Benthin teaches soft decision for bits, col. 5, lines 10-49)

converting said BLUETOOTH communication signal back to said analog music audio signal (inherent, output of digital payload of Mooney into headset 504, para. 0048) and communicating said analog

music audio signal to a headphone speaker (such as 26,28 of Alstatt) within the BLUETOOTH compliant headphone receiver (504 of Mooney, para. 0039, in view of 20 of Alstatt, col. 4, lines 48-51)

Regarding **Claim 5**, please refer above to the rejection of the similar limitations of Claim 2.

### **Conclusion**

Any inquiry concerning this communication or earlier communications from the examiner should be directed to Andrew Graham whose telephone number is 703-308-6729. The examiner can normally be reached on Monday-Friday, 8:30 AM to 5:00 PM (EST).

If attempts to reach the examiner by telephone are unsuccessful, the examiner's supervisor, Sinh Tran can be reached at 571-272-7564. The fax phone number for the organization where this application or proceeding is assigned is 703-872-9306.

Information regarding the status of an application may be obtained from the Patent Application Information Retrieval (PAIR) system. Status information for published applications may be obtained from either Private PAIR or Public PAIR. Status information for unpublished applications is available through Private PAIR only. For more information about the PAIR system, see <http://pair-direct.uspto.gov>. Should you have questions on access to the Private PAIR system, contact the Electronic Business Center (EBC) at 866-217-9197 (toll-free).



Application/Control Number: 10/648,012

Page 25

Art Unit: 2644



**SINH TRAN**  
**SUPERVISORY PATENT EXAMINER**

*AG*

Andrew Graham  
Examiner  
A.U. 2644

ag  
May 11, 2005

<b>Notice of References Cited</b>	Application/Control No. 10/648,012	Applicant(s)/Patent Under Reexamination WOOLFORK, C. EARL	
	Examiner Andrew Graham	Art Unit 2644	Page 1 of 1

**U.S. PATENT DOCUMENTS**

*	Document Number Country Code-Number-Kind Code	Date MM-YYYY	Name	Classification
A	US-2003/0045235 A1	03-2003	Mooney et al.	455/41
B	US-5,790,595 A	08-1998	Benthin et al.	375/224
C	US-5,771,441 A	06-1998	Altstatt, John E.	455/66.1
D	US-			
E	US-			
F	US-			
G	US-			
H	US-			
I	US-			
J	US-			
K	US-			
L	US-			
M	US-			

**FOREIGN PATENT DOCUMENTS**

*	Document Number Country Code-Number-Kind Code	Date MM-YYYY	Country	Name	Classification
N					
O					
P					
Q					
R					
S					
T					

**NON-PATENT DOCUMENTS**

*	Include as applicable: Author, Title Date, Publisher, Edition or Volume, Pertinent Pages)
U	Specification of the Bluetooth System, Version 1.0 B, pages 17-27, 4144, 81-86, 143-147.
V	Pohlman, K. C. Principles of Digital Audio. McGraw-Hill, Inc., 3 <sup>rd</sup> ed. 1995. pages 155-157.
W	
X	

\*A copy of this reference is not being furnished with this Office action. (See MPEP § 707.05(a).)  
Dates in MM-YYYY format are publication dates. Classifications may be US or foreign.

**Index of Claims**



Application/Control No.

10/648,012

Examiner

Andrew Graham

Applicant(s)/Patent under Reexamination

WOOLFORK, C. EARL

Art Unit

2644

√	Rejected
=	Allowed

-	(Through numeral) Cancelled
+	Restricted

N	Non-Elected
I	Interference

A	Appeal
O	Objected

Claim		Date			
Final	Original	5/10/05			
1	√				
2	√				
3	√				
4	√				
5	√				
6					
7					
8					
9					
10					
11					
12					
13					
14					
15					
16					
17					
18					
19					
20					
21					
22					
23					
24					
25					
26					
27					
28					
29					
30					
31					
32					
33					
34					
35					
36					
37					
38					
39					
40					
41					
42					
43					
44					
45					
46					
47					
48					
49					
50					

Claim		Date			
Final	Original				
51					
52					
53					
54					
55					
56					
57					
58					
59					
60					
61					
62					
63					
64					
65					
66					
67					
68					
69					
70					
71					
72					
73					
74					
75					
76					
77					
78					
79					
80					
81					
82					
83					
84					
85					
86					
87					
88					
89					
90					
91					
92					
93					
94					
95					
96					
97					
98					
99					
100					

Claim		Date			
Final	Original				
101					
102					
103					
104					
105					
106					
107					
108					
109					
110					
111					
112					
113					
114					
115					
116					
117					
118					
119					
120					
121					
122					
123					
124					
125					
126					
127					
128					
129					
130					
131					
132					
133					
134					
135					
136					
137					
138					
139					
140					
141					
142					
143					
144					
145					
146					
147					
148					
149					
150					

**Search Notes**



Application/Control No.

10/648,012

Examiner

Andrew Graham

Applicant(s)/Patent under Reexamination

WOOLFORK, C. EARL

Art Unit

2644

**SEARCHED**

Class	Subclass	Date	Examiner
700	94	5/10/2005	AG
714	709,780	5/10/2005	AG
706	8,9	5/10/2005	AG
455	3.06,41	5/10/2005	AG
455	66.1	5/10/2005	AG
375	224	5/10/2005	AG

**INTERFERENCE SEARCHED**

Class	Subclass	Date	Examiner

**SEARCH NOTES  
(INCLUDING SEARCH STRATEGY)**

	DATE	EXMR
EAST search using USPAT PGPUB DERWENT EPO JPO USOCR dbs	5/10/2005	AG
cls/sbcis at left w/ keywords Bluetooth, fuzzy, soft decision, bit energy, probability, membership, and equivalents	5/10/2005	AG
Parent application, including applied references, considered	5/10/2005	AG
Inventor search, using EAST and Internet search engine	5/10/2005	AG



UNITED STATES PATENT AND TRADEMARK OFFICE

UNITED STATES DEPARTMENT OF COMMERCE  
 United States Patent and Trademark Office  
 Address: COMMISSIONER FOR PATENTS  
 P.O. Box 1450  
 Alexandria, Virginia 22313-1450  
 www.uspto.gov



Bib Data Sheet

CONFIRMATION NO. 3337

SERIAL NUMBER 10/648,012	FILING DATE 08/26/2003  RULE	CLASS 700	GROUP ART UNIT 2644	ATTORNEY DOCKET NO.	
APPLICANTS C. Earl Woolfork, Pasadena, CA;  ** CONTINUING DATA ***** This application is a CIP of <del>10/027,799 12/20/2001 PAT 6,725,100</del> ↳ 10/027391, now abandoned. - X6  ** FOREIGN APPLICATIONS ***** na  IF REQUIRED, FOREIGN FILING LICENSE GRANTED ** SMALL ENTITY ** ** 11/18/2003					
Foreign Priority claimed <input type="checkbox"/> yes <input checked="" type="checkbox"/> no	35 USC 119 (a-d) conditions met <input type="checkbox"/> yes <input checked="" type="checkbox"/> no <input type="checkbox"/> Met after Allowance	STATE OR COUNTRY CA	SHEETS DRAWING 2	TOTAL CLAIMS 5	INDEPENDENT CLAIMS 3
Verified and Acknowledged Examiner's Signature: <u>AS</u> Initials: _____					
ADDRESS 42794 DENNIS W. BEECH (LAW OFFICE OF DENNIS W. BEECH) P.O. BOX 519 MURRIETA, CA 92564-0519					
TITLE Fuzzy audio wireless music system					
FILING FEE RECEIVED 375	FEES: Authority has been given in Paper No. _____ to charge/credit DEPOSIT ACCOUNT No. _____ for following:		<input type="checkbox"/> All Fees <input type="checkbox"/> 1.16 Fees ( Filing ) <input type="checkbox"/> 1.17 Fees ( Processing Ext. of time ) <input type="checkbox"/> 1.18 Fees ( Issue ) <input type="checkbox"/> Other _____ <input type="checkbox"/> Credit		



07-05-05

IFW

Law Offices of  
**DENNIS W. BEECH**

Landmark Building - Newland Center  
19900 Beach Blvd., Suite C-2  
Huntington Beach, CA 92648  
BUS: (714) 378-0212  
FAX: (714) 378-0262

Palmdale/Lancaster: (661) 273-0503  
Temecula/Murrieta: (909) 986-4624  
Brea/Ontario: (909) 986-4624  
Bakersfield: (661) 821-6911  
Fax: (714) 378-0262

**RESPOND TO: HUNTINGTON BEACH**

EXPRESS MAIL

EV482347002US

July 1, 2005

Mail Stop NON-FEE AMENDMENT  
Commissioner for Patents  
P.O. Box 1450  
Alexandria, VA 22313-1450

Serial Number: 10/648,012  
Applicant: C. Earl Woolfork  
Filing Date: 08/26/2003  
Title: WIRELESS DIGITAL AUDIO SYSTEM  
TC/AU: 2644  
Examiner: Graham, Andrew R.

TO THE COMMISSIONER FOR PATENTS:

The following is submitted in response to Examiner's Action, Paper No. 20050421, dated May 18, 2005.

Please amend the above identified application as follows:

## **AMENDMENTS**

**Amendments to the Specification** begin on page 3 of this paper.

**Amendments to the Claims** are reflected in the listing of claims that begins on page 9 of this paper.

**Amendments to the Drawings** begin on page 13 of this paper and include an attached replacement sheet.

**Remarks/Arguments** begin on page 14 of this paper.

## **AMENDMENTS TO THE SPECIFICATION**

In the Abstract of the Disclosure: (Place a replacement or new abstract on a separate sheet)

~~[0024]~~ ~~[0017]~~ The fuzzy audio wireless digital audio music system may utilize a battery powered ~~BLUETOOTH-compliant~~ transmitter to transmit a coded digital ~~BLUETOOTH~~ communication signal from an existing ~~non-BLUETOOTH~~ analog headphone jack of a music audio player device or source to a battery powered headphone receiver without the use of wires. A battery powered ~~BLUETOOTH-compliant~~ digital transmitter may include a headphone plug in communication with a standard analog headphone jack on a an audio source, such as, laptop and desktop computers, portable compact disc players, portable MP3 players, portable cassette players, etc. The battery powered ~~BLUETOOTH-compliant~~ transmitter adds a unique user code ~~as defined in the BLUETOOTH standard~~ and transmits it to the battery powered ~~BLUETOOTH-compliant~~ receiver headphones where a fuzzy logic detection system may be used to enhance decoding performance. The ~~BLUETOOTH-communication~~ FAWM wireless digital audio system will allow private listening without interference from other users, and without the inconvenience of wires.

In the Specifications:

Please replace the paragraphs and the beginning of the specification with the following rewritten paragraphs and beginning:

### **FUZZY AUDIO WIRELESS DIGITAL AUDIO MUSIC SYSTEM**

This is a continuation-in-part of application Serial No. 10/027,391  
which patent application is pending.

### **BACKGROUND OF THE INVENTION**

**[0001]** This invention relates to music audio player devices and more particularly to systems that include headphone listening devices. The new audio music system uses an existing ~~non-BLUETOOTH~~ headphone jack (i.e., this is the standard analog headphone jack that connects to wired headphones) of a music audio player (i.e., portable CD player, portable cassette player, portable A.M./F.M. radio, laptop/desktop computer, portable MP3 player, and the like) to connect a



battery powered ~~BLUETOOTH~~ compliant transmitter for digital wireless transmission of a ~~BLUETOOTH~~ communication signal to a set of battery powered ~~BLUETOOTH~~ compliant receiver headphones. ~~BLUETOOTH is a worldwide wireless standard. Detailed information regarding the standard is available on the web site www.bluetooth.com.~~

**[0002]** Use of music audio headphones with music audio player devices such as portable CD players, portable cassette players, portable A.M./F.M. radios, laptop/desktop computer, portable MP3 players and the like, have been in use for many years. These systems usually incorporate an audio source having ~~a~~ an analog ~~non-BLUETOOTH~~ headphone jack to which headphones may be connected by wire.

**[0003]** There are also known ~~non-portable~~ wireless headphones that may receive infrared (IR) A.M. and F.M. radio transmissions. However, ~~these systems operate with a narrow beam width that requires a point-and-shoot style for reception.~~ they do not allow use of a simple plug in (i.e., plug in to the existing analog audio headphone jack) battery powered ~~BLUETOOTH~~ compliant transmitter for connection to any music audio player device jack, such as the above mentioned music audio player devices, for coded digital wireless transmission and reception by ~~BLUETOOTH~~ compliant headphones of audio music for private listening to multiple users occupying the same space, without the use of wires. Existing audio systems make use of electrical wire connections between the audio source and the headphones to accomplish private listening to multiple users.

**[0004]** There is a need for a battery powered simple connection system for existing music audio player devices (i.e., the previously mentioned music devices), to allow coded digital wireless transmission (using a battery powered ~~BLUETOOTH~~ compliant transmitter) to a headphone receiver (using battery powered ~~BLUETOOTH~~ compliant receiver headphones) that accomplishes private listening to multiple users occupying the same space without the use of wires.

#### SUMMARY OF THE INVENTION

**[0005]** The present invention is directed to ~~FAWM (Fuzzy Audio Wireless Music) systems~~ a wireless digital audio music system for coded digital transmission, ~~per the BLUETOOTH standard,~~ of an analog audio signal from any music audio player device with an ~~non-BLUETOOTH~~ analog headphone jack to a receiver headphone, ~~which adheres to the BLUETOOTH standard.~~ Fuzzy logic technology may be utilized by the FAWM wireless digital audio music system to enhance bit detection. A battery powered ~~BLUETOOTH~~ compliant transmitter may include a headphone plug in communication with any of the previously mentioned music audio sources. For reception, a battery

powered ~~BLUETOOTH-compliant~~ headphone receiver may apply fuzzy logic to enhance user code bit detection. Fuzzy logic detection may be used to enhance user code bit detection during decoding of the ~~BLUETOOTH-communication~~ signal. The ~~FAWM-wireless digital audio music~~ system will provide private listening without interference from other users and without the use of wires.

[0006] These and other features, aspects and advantages of the present invention will become better understood with reference to the following drawings, description and claims.

#### BRIEF DESCRIPTION OF THE DRAWINGS

[0007] Figure 1 illustrates a schematic diagram representation of the ~~FAWM-wireless digital audio music~~ system according to and embodiment of the invention;

Figure 2 illustrates a schematic diagram representation of the FAWM transmitter according to an embodiment of the invention;

Figure 3 illustrates a schematic diagram representation of the FAWM receiver without the use of the fuzzy logic enhancement according to an embodiment of the invention;

Figure 2 4 illustrates a schematic diagram representation of the FAWM system with the use of the fuzzy logic enhancement a graph of the high and low bit fuzzy logic if-then-part fuzzy set according to an embodiment of the invention.

#### DETAILED DESCRIPTION

[0008] The following detailed description is the best currently contemplated modes for carrying out the invention. The description is not to be taken in a limiting sense, but is made merely for the purpose of illustrating the general principles of the invention.

[0009] Referring to Figure ~~Figures 1 through 3~~, a ~~FAWM-wireless digital audio music~~ system 10 may include a battery powered ~~BLUETOOTH-compliant~~ transmitter 20 connected to a portable music audio player or music audio source 80. The battery powered ~~BLUETOOTH-compliant-wireless digital audio music~~ transmitter 20 that utilizes a ~~CODEC an analog to digital converter or ADC 32 and~~ ~~BLUETOOTH~~ front-end may be connected to the music audio source 80 analog non-~~BLUETOOTH~~ headphone jack 82 using a headphone plug 22. The battery powered ~~BLUETOOTH~~

compliant transmitter 20 may have a transmitting antenna 24 that may be omni-directional for transmitting a spread spectrum modulated signal, which adheres to the BLUETOOTH standard, to a receiving antenna 52 of a battery powered BLUETOOTH compliant headphone receiver 50. The battery powered BLUETOOTH compliant receiver 50 may have headphone speakers 54 in headphones 55 for listening to the spread spectrum demodulated and decoded BLUETOOTH communication signal. In the headphone receiver 50, During decoding, fuzzy logic detection may be used to optimize reception of the received user code. increase receiver decoding performance. The FAWM-BLUETOOTH compliant transmitter 20 may digitize the audio signal per the BLUETOOTH standard using a CODEC an ADC 32 that may be in communication with an encoder 36. and BLUETOOTH front-end. This BLUETOOTH compliant digital signal has a throughput of approximately 1.4 Mbps that may be as low as approximately 1.0 Mbps. After digital conversion, the digital signal may be processed by a digital low pass filter 34. To reduce the effects of channel noise, the battery powered BLUETOOTH compliant transmitter 20 may use channel encoding 38. A modulator 48 modulates the digital signal to be transmitted. For further noise immunity, spread spectrum modulation 42, as defined in the BLUETOOTH standard is utilized. The battery powered BLUETOOTH compliant transmitter 20 may contain a BLUETOOTH compliant code shift register generator 44 (SRG), or the like, that may be used to create a unique user code. The unique user code generated is specifically associated with one FAWM wireless digital audio music system user, and it is the only code recognized by the battery powered FAWM-BLUETOOTH compliant headphone receiver 50 operated by a particular user. The radio frequency (RF) spectrum utilized (as taken from the Industrial, Scientific and Medical (ISM) band), may be approximately 2.4 GHz, as defined in the BLUETOOTH standard. And the power radiated by the BLUETOOTH compliant transmitter adheres to the ISM ~~ISM~~ BLUETOOTH standard.

[0010] Referring to Figure Figures 1 through 4, the spread spectrum modulated BLUETOOTH compliant signal from transmit antenna 24 may be received by receiving antenna 52 and then spread spectrum demodulated 62 with a receiver code generator 60 that contains the same transmitted unique code per the BLUETOOTH standard, in the battery powered BLUETOOTH compliant receiver 50 headphones. The transmitted signal from transmit antenna 24 may be received by receiving antenna 52 and communicated to a wideband bandpass filter (BPF) 64. The received digital signal may be processed by a demodulator 58 (Figure 3). The battery powered BLUETOOTH compliant receiver 50 may utilize fuzzy logic 61 (as best viewed in Figure 4) to optimize the bit detection of the received packet user code.

[0011] Each BLUETOOTH compliant receiver headphone 50 user may be able to listen

(privately) to high fidelity audio music, using any of the audio devices listed previously, without the use of wires, and without interference from any other ~~BLUETOOTH-compliant~~ receiver headphone user. The fuzzy logic detection technique 61 that may be used in the FAWM\_receiver\_50 could provide greater user separation through optimizing code division in the ~~BLUETOOTH-compliant~~ headphone receiver.

**[0012]** The battery powered ~~BLUETOOTH-compliant~~ transmitter 20 sends the audio music information to the battery powered ~~BLUETOOTH-compliant~~ receiver 50 in digital packet format as defined in the ~~BLUETOOTH~~ standard. Each packet may consist of, at minimum, a start bit to indicate the beginning of a packet, the unique user code, the digitized audio information and a stop bit to indicate the end of a packet. These packets may flow to create a digital bit stream rate of less than or equal to 1.0 Mbps as defined in the ~~BLUETOOTH~~ standard.

**[0013]** The user code bits in each packet may also be received and detected by a fuzzy logic detector detection 61 system (as an option) in the headset receiver 50 to provide additional receiver decoding performance. For each consecutive packet received, the fuzzy logic detector detection system may compute a conditional density with respect to the context and fuzziness of the user packet code vector, i.e., the received code bits in each packet. ~~The fuzzy logic detection system FAWM-BLUETOOTH-compliant receiver 50 to accurately detect the assigned user code packet code in the presence of noise, which may include other FAWM users.~~ Fuzziness may describe the ambiguity of the high bit (1)/low bit (0 or -1) bit event in the noisy received user code within the packet. The fuzzy logic detection system 61 may measure the degree to which a high/low bit occurs in the user packet code vector, which produces a low probability of bit error in the presence of noise. The fuzzy logic detector detection system 61 may use a set of if-then rules to map the user code bit inputs to validation outputs. These rules may be developed as if-then statements 61.

**[0014]** The fuzzy logic detection system 61 in the battery powered ~~BLUETOOTH-compliant~~ headphone receiver 50 utilizes the if-then fuzzy set to map the received user code bits into two values; a low (0 or -1) and a high (1). Thus, as the user code bits are received, the "if" rules map the signal bit energy to the fuzzy set low value to some degree and to the fuzzy set high value to some degree. See Figure 2.4 schematic block 61. Figure 2.4 schematic block 61 shows that -1 equals the maximum low bit energy representation and 1 equals the maximum high bit energy representation. Due to additive noise, the user code bit energy may have some membership to low and high as represented in 61 of Figure 2.4. The if-part fuzzy set may determine if each bit in the user code, for every received packet, has a greater membership to a high bit representation or a low bit representation. The more a user code bit energy fits into the high or low representation, the

closer its subsethood, i.e., a measure of the membership degree to which a set may be a subset of another set, may be to one.

~~[0015]~~

~~[0016]~~

~~[0017]~~

~~[0018]~~

~~[0019]~~ ~~[0015]~~ The if-then rule parts that make up the fuzzy logic detection system 61 must be followed by a defuzzifying operation. This operation reduces the aforementioned fuzzy set to a bit energy representation (i.e., -1 or 1) that is received by the transmitted ~~BLUETOOTH~~ standard packet. The fuzzy logic detection system 61 may be used in the battery powered ~~BLUETOOTH~~ compliant headset receiver 50 to enhance overall ~~FAWM~~ system 10 decoding performance.

~~[0016]~~ A channel decoder 66 may be in communication with the bandpass filter (BPF) 64. A ~~CODEC~~ decoder 68 may be in communication with a digital to analog converter or DAC 70 that may convert the digital signal back to an analog audio music signal. An analog low pass filter 72 may be used to filter the analog audio music signal to pass a signal in the approximate 20 Hz to 20 kHz frequency range and filter other frequencies. The analog audio music signal may then be processed by a power amplifier 74 that may be optimized to for powering headphone speakers 54 to optimize a high quality, low distortion audio music signal for hearing by a user wearing the headphones 55.

~~[0020]~~ ~~[0017]~~ While the invention has been particularly shown and described with respect to the illustrated and preferred embodiments thereof, it will be understood by those skilled in the art that the foregoing and other changes in form and details may be made therein without departing from the spirit and scope of the invention.

## **AMENDMENTS TO THE CLAIMS**

This listing of claims will replace all prior versions, and listings, of claims in the application:

### **Listing of Claims:**

1. (currently amended): A ~~fuzzy audio~~ wireless digital audio music system for ~~spread spectrum~~ BLUETOOTH communication of an audio music signal from the ~~non-BLUETOOTH~~ analog headphone jack connected to a battery powered ~~BLUETOOTH-compliant spread spectrum~~ transmitter and received by a battery powered ~~BLUETOOTH-compliant spread spectrum~~ headphone receiver comprising:

~~a an~~ NON-BLUETOOTH-compliant analog headphone jack from an audio music source in communication with ~~said a~~ battery powered BLUETOOTH-compliant digital transmitter;

~~said battery powered BLUETOOTH-compliant digital~~ transmitter converts an analog audio music signal from said existing ~~non-BLUETOOTH~~ analog headphone jack to a BLUETOOTH-compliant digital signal using ~~a CODEC and a BLUETOOTH front-end~~ an ADC in communication with an encoder at a signal rate of ~~less than~~ approximately 1.4\_1.0 Mbps ~~as defined in the~~ BLUETOOTH standard;

~~said CODEC encoder~~ in communication with a ~~shift register generator that is~~ BLUETOOTH-compliant to create a unique user code and a convolutional channel encoder;

~~said shift register generator~~ channel encoder in communication with a digital low pass filter ~~spread spectrum modulator that is BLUETOOTH-compliant~~;

~~said BLUETOOTH-compliant digital low pass filter~~ spread spectrum modulator in communication with a digital modulator ~~transmit antenna for BLUETOOTH-compliant transmission of a coded BLUETOOTH-compliant packet to a receiving antenna at a radio frequency of approximately 2.4 GHz as defined in the BLUETOOTH standard~~;

~~said digital modulator~~ in communication with a spread spectrum communication modulator that utilizes a code generator to create user code;

~~said spread spectrum communication modulator~~ in communication with a transmit antenna that transmits at a radio frequency of approximately 2.4 GHz for receipt by a receiving

antenna;

said receiving antenna in communication with a spread spectrum communication demodulator that is BLUETOOTH compliant and a convolutional decoder; and

said BLUETOOTH compliant spread spectrum communication demodulator in communication with a receiver code generator and with a digital demodulator;

said digital demodulator in communication with a wide bandpass filter;

said wide bandpass filter in communication with a channel decoder a fuzzy logic detection system for additional decoding performance.;

said channel decoder in communication with a receiver decoder;

said receiver decoder in communication with a DAC;

said DAC in communication with a low pass filter to pass the analog music signal in the approximate frequency band of 20 Hz to 20 kHz; and

said low pass filter passing analog music signal will be amplified for processing to a speaker headphone set to provide high quality music for listening by a single user wearing the headphones.

2. (canceled):

3. (canceled):

4. (currently amended): A method for battery powered wireless BLUETOOTH communication transmission and reception of high fidelity audio music between a battery operated BLUETOOTH compliant digital transmitter and a battery operated BLUETOOTH compliant digital receiver headphone comprising the step of:

connecting a headphone the plug attached to said battery operated BLUETOOTH compliant digital transmitter to the existing non-BLUETOOTH compliant analog headphone jack of an audio music source;

converting a music audio signal to a BLUETOOTH digital communication signal using an ADC in communication with an encoder a CODEC and a BLUETOOTH front end;

encoding the BLUETOOTH communication signal using BLUETOOTH standard channel encoding;

digital low pass filtering the communication signal;

modulating the digital communication signal using a digital modulator;

creating a ~~BLUETOOTH standard~~ spread spectrum signal using a ~~code shift register~~ generator to modulate a unique user code ~~that adheres to the BLUETOOTH standard~~;

transmitting said ~~BLUETOOTH standard~~ spread spectrum signal at a radio frequency of approximately 2.4 GHz at a power level ~~that adheres to the BLUETOOTH standard~~ for reception at a distance ~~less than~~ up to approximately 10 30 feet from said battery operated ~~BLUETOOTH compliant~~ transmitter;

receiving said ~~BLUETOOTH compliant~~ spread spectrum signal at said battery operated ~~BLUETOOTH compliant~~ receiver headphones;

demodulating said ~~BLUETOOTH compliant~~ spread spectrum signal;

demodulating said digital communication signal;

bandpass filtering said digital communication signal;

~~channel~~ decoding of said ~~BLUETOOTH digital~~ communication signal ~~as defined in the BLUETOOTH standard, with an option to apply fuzzy logic detection system to enhance bit detection performance~~;

converting said ~~BLUETOOTH digital~~ communication signal back to said analog music audio signal using a ~~CODEC decoder in communication with a DAC~~; and

communication said analog music audio signal to a headphone speaker within the ~~BLUETOOTH compliant~~ headphone receiver.

5. (canceled):

6. (new): An audio music digital wireless transmitter for spread spectrum communication of an audio music signal from an analog headphone jack connected to a battery powered spread spectrum transmitter comprising:

an analog headphone jack from an audio music source in communication with a battery powered digital transmitter;

said battery powered digital transmitter converts an analog audio music signal from said existing analog headphone jack to a digital signal using an ADC in communication with an encoder at a signal rate of less than approximately 1.0 Mbps ;

said encoder in communication with a channel encoder;

said channel encoder in communication with a digital low pass filter ;

said digital low pass filter in communication with a digital modulator ;

said digital modulator in communication with a spread spectrum communication



modulator that utilizes a code generator to create user code; and

said spread spectrum communication modulator in communication with a transmit antenna that transmits at a radio frequency of approximately 2.4 GHz for receipt by a receiving antenna.

7. (new): An audio music digital wireless receiver for spread spectrum communication of an audio music signal to be received by a battery powered spread spectrum headphone receiver comprising:

a receiving antenna in communication with a spread spectrum communication demodulator

said spread spectrum communication demodulator in communication with a code generator and with a digital demodulator;

said digital demodulator in communication with a wide bandpass filter;

said wide bandpass filter in communication with a channel decoder;

said channel decoder in communication with a decoder;

said decoder in communication with a DAC;

said DAC in communication with a low pass filter to pass the analog music signal in the approximate frequency band of 20 Hz to 20 kHz; and

said low pass filter passing analog music signal will be amplified for processing to a speaker headphone set to provide high quality music for listening by a single user wearing the headphones.

**Amendments to the Drawings:**

The attached sheets of drawings include corrections made to original Figures 1 and 2, the renumber of Figure 2 to Figure 4, and the addition of Figures 2 and 3 based on the examiner's comments. These sheets replace original sheets 1 and 2.

Attachment: 2 Replacement Sheets and 1 New Sheets.

## **REMARKS/ARGUMENTS**

The recitations requested by the examiner to be cancelled in Office Action paragraph 2 and the claim rejections in Office Action paragraph 4 based on 35 USC 112, first paragraph, have been corrected in the amendments in this response except for the reference to a spread spectrum modulation technique of Gaussian frequency shift keying (GFSK) and reference to a digital low pass filter. It is believed these are part of the original disclosure. New claims 6 and 7 have been added. Support for these claims is found in the original application, claims 1 and 5 and in the continuation-in-part application specification.

While the term Gaussian frequency shift keying (GFSK) was not mentioned in the original disclosure, it is stated that DPSK may be (not that it necessarily will be) utilized [original patent application, pg 4/lines1-2] as a spread spectrum modulation technique. The original disclosure was written to specify that a spread spectrum modulation technique is used [original patent application, pg 4/lines 8 & 11-12]. The type of spread spectrum modulation technique used is dependent on the spread spectrum system that most effectively applies to the invention (i.e., direct sequence spread spectrum or frequency hopping spread spectrum). The following shows how the original disclosure was written to include the use of a phase shift keying (PSK) modulation scheme for a direct sequence spread spectrum (DSSS) system or a frequency shift keying (FSK) modulation scheme for a frequency hopping spread spectrum system.

Characterizing the performance of a modulation method is a key step for comparison of different modulation techniques. If it can be shown that two modulation techniques are equal in performance, then it can be said that their performance characteristics are the same. Therefore, the two modulation techniques under comparison are interchangeable.

A performance comparison of the bit error probability of DPSK (differential phase shift keying) to both Noncoherent FSK (frequency shift keying), and coherent FSK [reference texts: Digital Communication Techniques by M.K Simon, S.M. Hinedi, W.C. Lindsey (Chapter 7) and Wireless Communications by Theodore S. Rappaport (Chapter 5)] is now presented. It can be proven that the performance characteristics between DPSK and coherent FSK detection are the same. Also, aside from a 3 dB difference in signal-to-noise ratio (SNR), the performance characteristics between DPSK and noncoherent FSK are the same.

In what follows, the thread that ties DPSK and FSK modulation and detection techniques together is disclosed. The basis of this thread is a special case of a unified analysis of certain coherent and noncoherent binary communication systems performed many years ago by S. Stein ["Unified analysis of certain coherent and noncoherent binary communications systems," IEEE Transactions on Information Theory, vol. IT-10, no. 1, January 1964, pp. 43-51], which still stands as a classic contribution in the field.

Consider the optimum DPSK receiver of Figure 7.2b (see page 443 of Digital Communication Techniques) and the optimum coherent (see Figure 5.36 on page 258 of Rappaport) and noncoherent receiver (see Figure 7.6 on page 458 of Digital Communication Techniques). We will compare the error probability performances of these receivers for both messages  $m_0$  and  $m_1$ , which are defined on page 457 of Digital Communication Techniques for the two different modulation/detection techniques. Please see pages 457,459 and 460 of Digital Communication Techniques for the remainder of the proof.

In view of the proof, Figure 5.53 on page 287 of Rappaport, shows the performance curves that support the proof. Further, Figure 5.53 of Rappaport clearly shows that the mathematical proof given applies to the performance comparison of FSK coherent modulation/detection technique and DPSK modulation/detection technique. The coherent FSK has the same probability statistics as DPSK. This holds because the DPSK independent Gaussian random variables and variance are equal to the coherent FSK independent Gaussian random variables and variance. Therefore, the comparison case of error probability performance between coherent FSK and DPSK does not have a 3 dB difference in SNR (see page 287 of Rappaport). The 3 dB difference in SNR between DPSK modulation/detection and noncoherent modulation/detection can be seen in Figure 5.53 on page 287 of Rappaport. Further, page 286 of Rappaport supports the coherent FSK and DPSK bit error probability performance similarities in equations 5.160 and 5.161. As proven, the performance of coherent FSK modulation/detection and DPSK modulation/detection are similar.

Given the performance characteristics (shown in the proof) and the hardware architecture of coherent FSK and DPSK, the original disclosure stated that DPSK modulation/detection may be used (given a DSSS system choice). But, within the scope of the invention [the "FAWM allows multiple user operation within the same space." (original application pg 4/lines 21-22 & continuation-in-part application pg 1/lines 28-29)], a coherent FSK modulation/detection technique could be used

given a FHSS system choice.

A note about the digital low pass filter disclosed. The digital low pass filter was disclosed in the original patent application on pg 3/line19. This digital low pass filter is a premodulation pulse shaping type that can control sidelobe levels (i.e., "reduce unwanted out of band noise") to produce good spectral efficiency and also create good constant envelope properties.

The CODEC function was disclosed within the original application as A/D and D/A conversion and compression. A CODEC (also called an A/D converter) is defined as Coder/decoder equipment (in this case integrated chip) used to convert and compress analog video and audio signals into a digital format for transmission, then convert them back to analog signals upon reaching their destination. This was disclosed as two elements in the original application (pg 3/lines15-17). The A/D converter serves to convert and compress the analog music signal. By stating that a "4 bit A/D converter" is utilized, it is understood (based on the scope of the invention) that the analog music information is compressed (see page 131 of Communication Networks: A First Course, by Jean Walrand) because of the low number of bits (4 bits) needed to transmit a portion of the information. The number of bits needed to transmit a given piece of information can be reduced by a technique called information compression [Communication Networks: A First Course, by Jean Walrand, page 131]. It is stated in the original application (pg 3/line15) that the "approximate range" is 20Hz to 20kHz (analog music frequency band), so the bit rate at this point can be calculated as follows:

$$(48\text{kHz}) \times (4\text{bits}) \times 2 = 384 \text{ kbps} \quad [\text{compressed}] \quad (1)$$

where, 48kHz is the sample rate (this satisfies Nyquist's sampling theorem), the quantization is 4 bits, and the 2 represents the right and left audio channel

$$(48\text{kHz}) \times (16\text{bits}) \times 2 = 1.53\text{Mbps} \quad [\text{uncompressed}] \quad (2)$$

$$(96\text{kHz}) \times (4\text{bits}) \times 2 = 768 \text{ kbps} \quad [\text{compressed}] \quad (3)$$

$$(96\text{kHz}) \times (16\text{bits}) \times 2 = 3.0\text{Mbps} \quad [\text{uncompressed}] \quad (4)$$

$$(128\text{kHz}) \times (4\text{bits}) \times 2 = 1\text{Mbps kbps} \quad [\text{compressed}] \quad (5)$$

$$(128\text{kHz}) \times (16\text{bits}) \times 2 = 4.0\text{Mbps} \quad [\text{uncompressed}] \quad (6).$$

Therefore, as disclosed within the original application and the continuation-in-part application, and presented in equations (1), (3) & (5), the invention will operate at a bit rate of less than or equal to 1Mbps and an A/D converter may be utilized. The use of the word CODEC has been deleted to avoid confusion.

The drawings have been objected to under 37 CFR 1.83 (a) as not showing every feature of the invention specified in the claims. The drawings have been corrected and new sheets added based on the original disclosure and drawings to show the features claimed.

Claims 4 and 5 have been rejected under 35 USC 112, first paragraph, as failing to comply with the enablement requirement. The "option" wording in claim 4 has been removed by amendment and the claim 5 fuzzy logic method clarified concerning dependency on claim 4. The BLUETOOTH terminology has been removed such that "convolutional" with respect to BLUETOOTH has become moot.

Claim 3 has been rejected under 35 USC 112, second paragraph, as being indefinite for use of the word possibly. The word has been removed in this amendment.

Claims 1 through 5 have been rejected under 35 USC 103 (a) as being unpatentable over Mooney, et al., in view of Altstatt and Benthin, et al.

Mooney's invention is for cell phone use (he references cell phone operation with his invention) where the audio is voice (which has a maximum bandwidth of about 3kHz); the patent never discloses the use of the invention with stereo music audio (which has a maximum bandwidth of about 20kHz). Further, Mooney does not discuss a device like the instant invention [See claim 1 ] that connects to portable MP3 players, portable CD players, portable cassette players, laptop computer or desktop computer to provide wireless stereo music audio.

Furthermore, There are differences between speech and music spectra and there are also differences between the perceptual requirements for speech and for music. Compared with music, speech tends to be a well-controlled spectrum with well established and predictable perceptual characteristics. In contrast, musical spectra are highly variable and the perceptual requirements can vary based on the music being played.

Mooney's BLUETOOTH cell phone system acts like a bandpass filter passing energy between approximately 200 Hz and 3.2 kHz (this is the typical telephone audio bandwidth).

In contrast the instant invention passes energy between approximately 20 Hz and 20 kHz (the typical audio bandwidth for music perception) [claim 1]. It is clear that the design parameters for music transmission/reception differ from speech design parameters. In fact, Mooney specifically points out that the invention uses the SCO (Synchronous Connection Oriented) link. This link provides a uniform bandwidth for both transmit and receive communication at a data rate of 64 kbps in both the transmit and receive directions (i.e., 64 kbps download speed in the transmit direction and 64 kbps upload speed in the receive direction). However, the invention uses a packet switching link (asynchronous link) method that has a high download speed (up to approximately 1 Mbps data rate from the transmitter to the receiver) [claims 1 & 6], but a slow upload speed (the acknowledgement status signal that flows from the receiver to the transmitter has a data rate of approximately 60 kbps). Clearly, this makes the elements for the instant invention different than the Mooney disclosure.

Altstatt's invention utilizes the FM band of local stations. The disclosure states that the invention is designed to not interfere with local stations. Altstatt makes no references to multiple independent users utilizing the invention in the same space without interference with each other (as disclosed in the invention that uses digital coding to eliminate user interference) [claim1]. Altstatt's invention seems to incorporate analog circuitry within the design (the instant invention uses coded digital circuitry while incorporating spread spectrum communications technology) [claim 1].

Based on the attached additional supporting documents and Declarations of the applicant it is believed that the Mooney art doesn't actually disclose nor anticipate these elements as disclosed and claimed in the instant application. Mooney does something quite different and doesn't anticipate the instant invention as it address the issues of interaction with a cellular telephone. In this action two

other patents have been combined with Mooney to argue that the instant application is obvious. In the Altstatt case the disclosure is a very simple RF device with no provision for adjacent user differentiation and in the Benthin disclosure the invention relates to probability and not fuzzy logic principles. Even in cases where a single prior art reads more closely on a device where rearrangement of parts is a patentability issue, "The mere fact that a worker in the art could rearrange the parts of the reference device to meet the terms of the claims on appeal is not by itself sufficient to support a finding of obviousness. The prior art must provide a motivation or reason for the worker in the art, without the benefit of appellant's specification, to make the necessary changes in the reference device". Ex parte Chicago Rawhide Mfg. Co., 223 USPQ 351, 353 (underline added, MPEP 2144.04, VI, C). It is believed in this instance there is no prior anticipation of the instant invention combination to accomplish the intended purpose.

For all of these reasons it is believed claims should be allowed.

Accordingly it is believed that the rejections under 35 USC Section 103(a) have been overcome by the remarks and additional evidence, and withdrawal thereof is respectfully requested. It is believed the 35 USC Section 112 objections/rejections have been corrected as requested.

In view of the above, it is submitted that the claims are in condition for allowance. Reconsideration of the cause for rejections and objections is requested. Allowance of claims 1, 4, 6 and 7 is earnestly solicited.

No additional fee for claims is seen to be required.

If you have any questions do not hesitate to contact me.

Very truly yours,



DENNIS W. BEECH  
Reg. No.: 35,443

DWB/ab

Attachments: 3 Drawing Sheets  
1 Page Information Disclosure Statement w/ 22 Pages  
2 Pages Declaration Under 37 CFR 1.132 w/ 30 Pages



REPLACEMENT SHEET

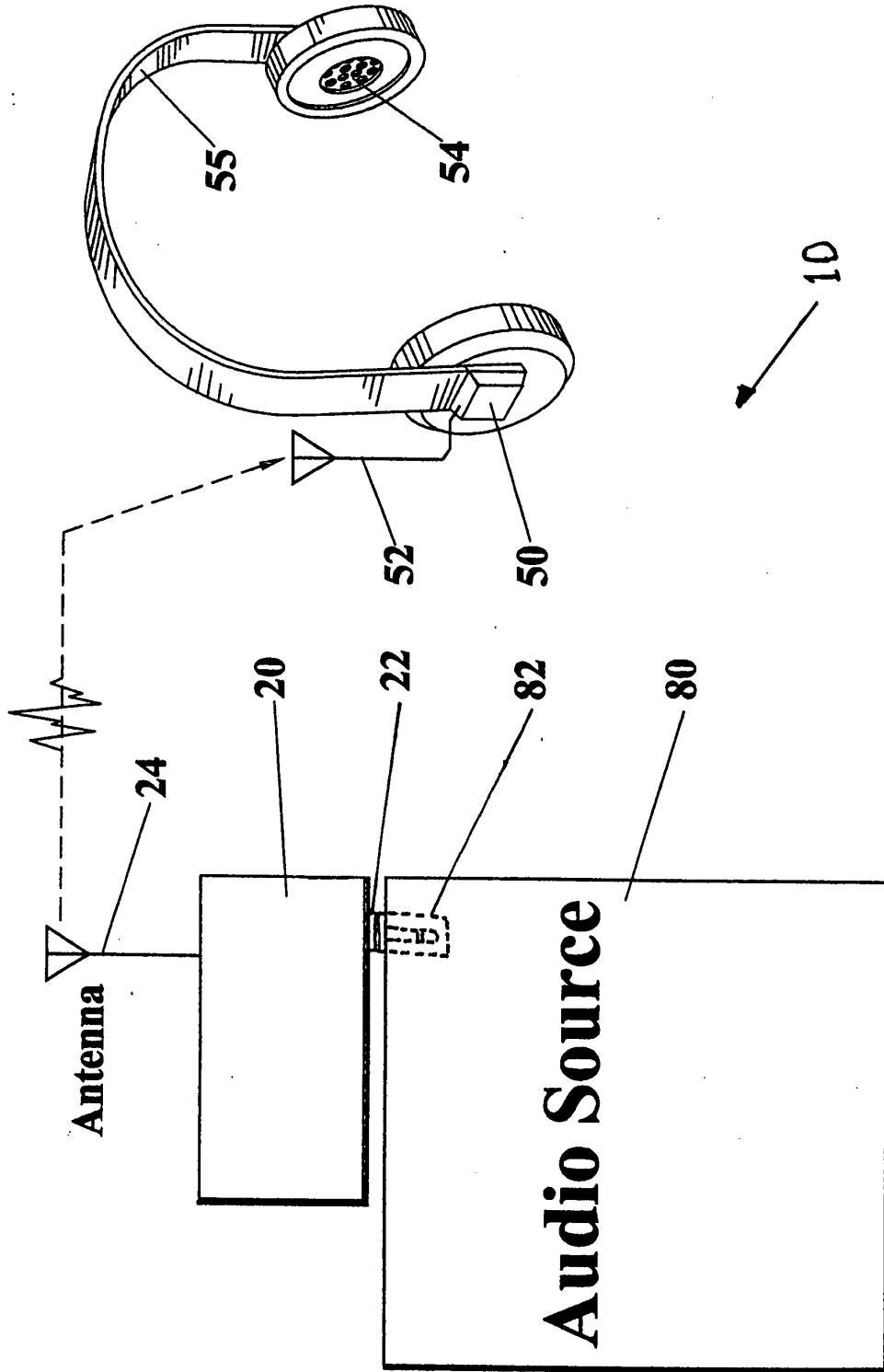

FIG.1

NEW SHEET

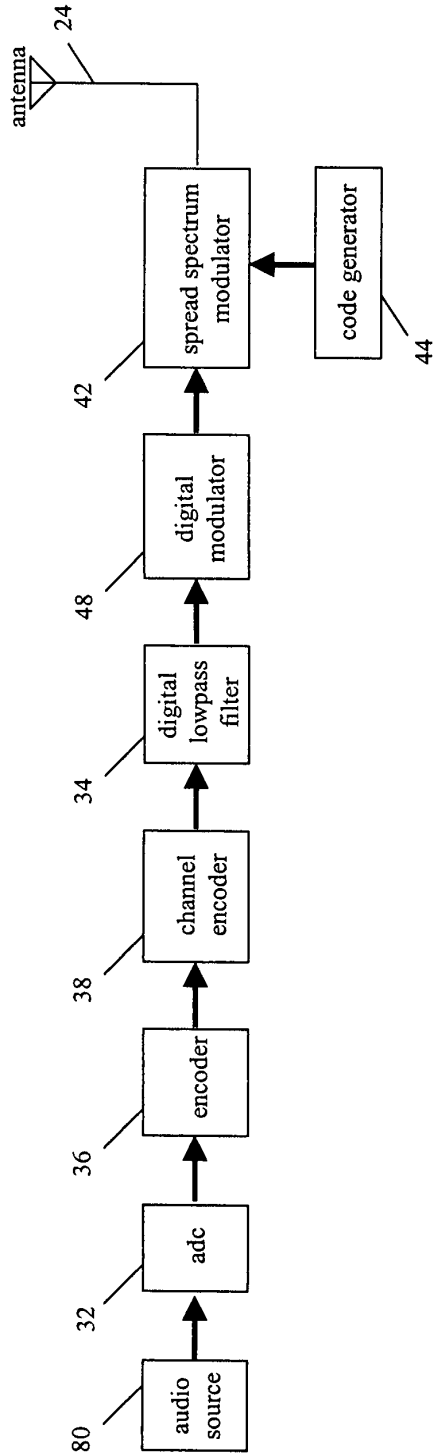

Figure 2

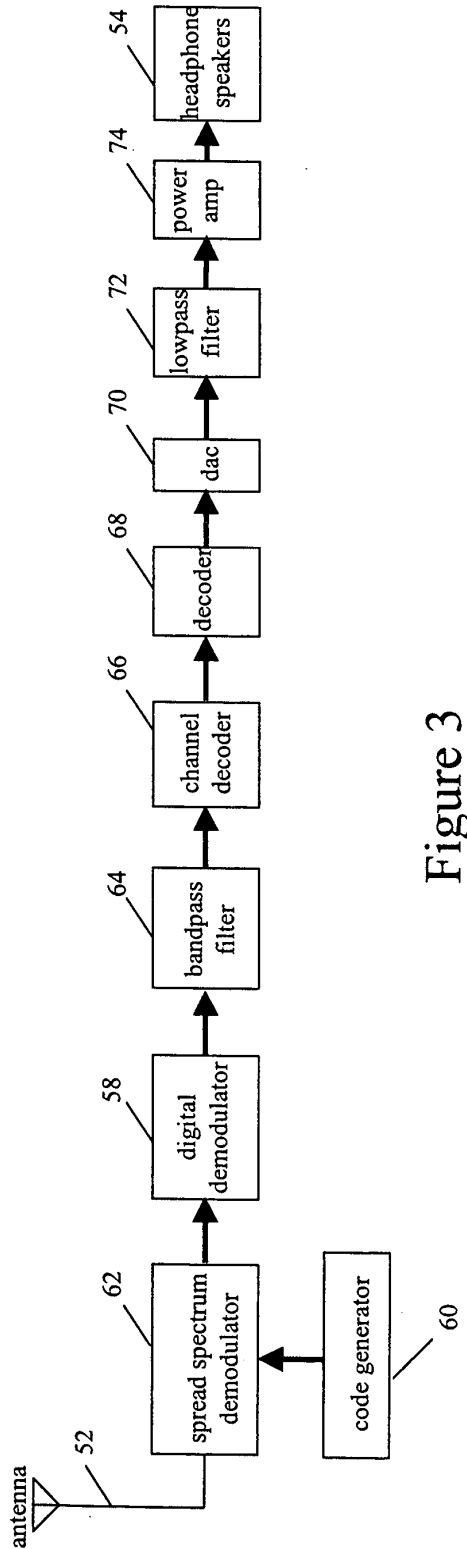

Figure 3

# REPLACEMENT SHEET

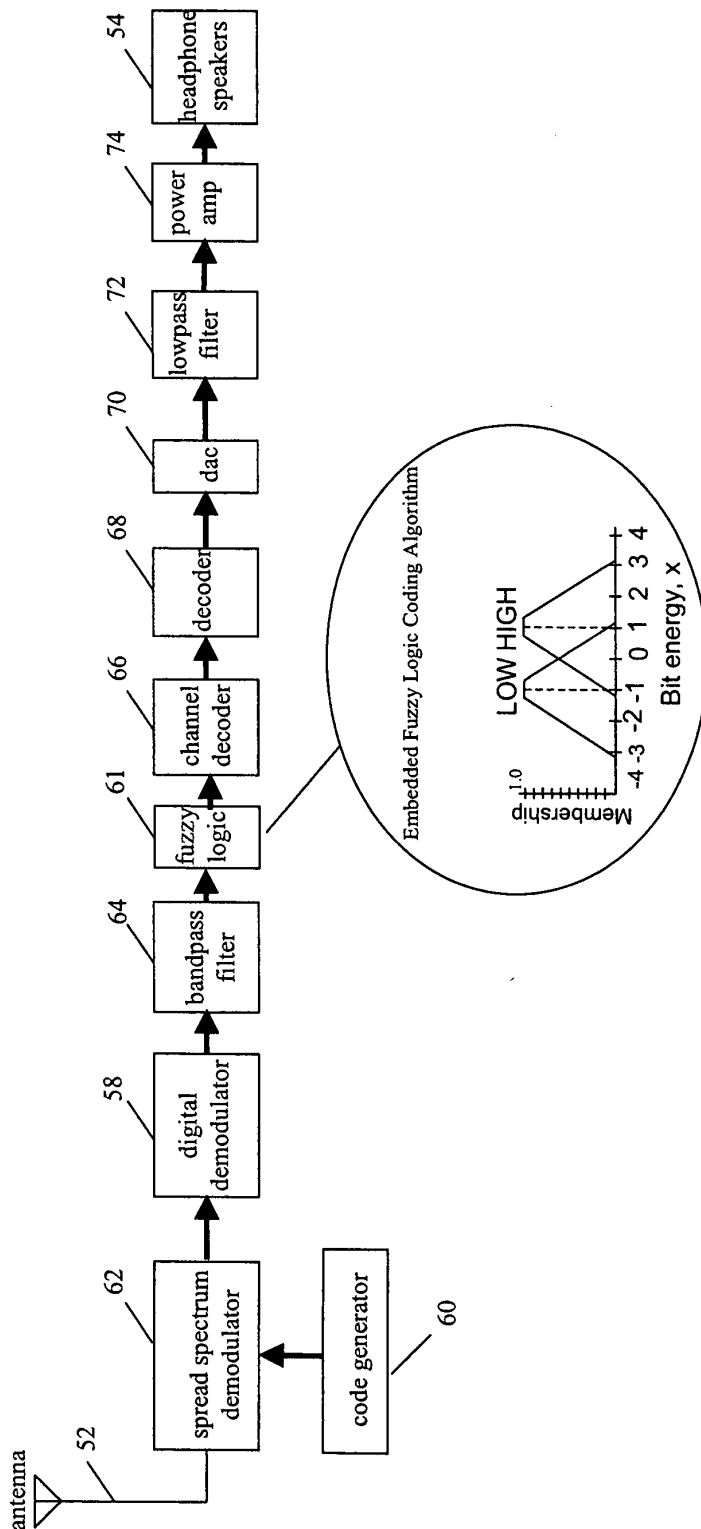

Figure 4



Patent Application No. : 10/648,012  
 Applicant : C. Earl Woolfork  
 Filing Date : 08-26-2003  
 Group Art Unit : 2644  
 Examiner : Graham, Andrew R.  
 For : FUZZY AUDIO WIRELESS MUSIC SYSTEM

**DECLARATION UNDER 37 CFR § 1.132**

In accordance with 37 CFR § 1.132, I hereby declare that

Further comments on the nonobviousness of the wireless digital audio music system invention. Attention will be focused on tribute paid to the instant invention system and the long need in the art for the solution the system provides. On June 26, 2003 the Wireless Digital Audio System patent application was made public on the U.S. Patent Office website. Clearly, it was available for all to see and learn from [Original Patent Application 10/027,391 ]. Such was the case with a company named Bluetake, because Bluetake marketed the "i-phono" approximately one (1) year after the invention was made public. The "i-phono" is discussed within the petition to make special that was filed by applicant on October 25, 2004. A committee within the US Patent Office granted the petition. Bluetake's i-phono functions in the same way as the disclosed invention (see filed petition to make special).

Similarly, Motorola has plans to release (scheduled 2<sup>nd</sup> quarter of 2005) their new wireless stereo headset system. It consists of a "DC800" transmitter that connects to the headphone jack of any of the devices mentioned by applicant earlier (portable MP3 payers, portable CD players, portable cassette players, laptop computer or desktop computer), and a "HT820" receiver headphone. Motorola's wireless stereo system functions in the same way as the disclosed invention. The reason for the design similarities is obvious. In August of 2004 I disclosed the instant invention to Motorola hoping that a business relationship would be developed (i.e., establish a license agreement with Motorola to mass produce the invention).

After several documented fax and phone communications, Motorola appeared to show no interest and stated that "it is not the direction their company is going."

These two cases are brought to the Examiner's attention to show the level of interest in the invention is great. The fact that both of the companies discussed (Bluetake & Motorola), have taken the steps to quickly mass produce a duplication of the invention brings merit to support the case of nonobviousness. Clearly, Bluetake and Motorola pay tribute to and recognize the long felt need of the invention.

Attached are documents relating to contracts with Motorola and advertisements for the Company's new product.

I hereby declare that all statements made herein of my own knowledge are true and that all statements made on information and belief are believed to be true; and further that these statements are made with the knowledge that willful false statements and the like so made are punishable by fine or imprisonment, or both, under Section 1001 of Title 18 of the United States code and that such willful false statement may jeopardize the validity of the application or any patent issue thereon.

Dated:

6/30/05

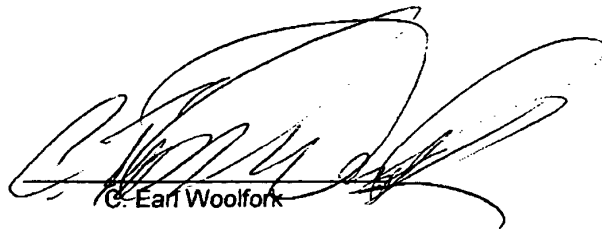

G. Earl Woolfork

JOB STATUS REPORT

TIME : 08/12/2004 06:36  
NAME :  
FAX# :  
TEL# :

DATE, TIME	08/12 06:36
FAX NO., NAME	918475762569
DURATION	00:00:42
PAGE(S)	05
RESULT	OK
MODE	STANDARD ECM

BEST AVAILABLE COPY

**TO:**

Cathy McMillian

**NAME:** Motorola  
**COMPANY**

**DATE:** 8/12/04

**TELEPHONE:** (847) 576-0278 **FAX:** (847) 576-2569

**# OF PAGES**  
**(INCLUDING COVER)** 5

**FROM:**

C. EARL WOOLFORD

**NAME:** EARL WOOLFORD  
**BLDG / MS:**

**ORG.**

**TELEPHONE:** (818) 625-4966

**FAX:**

**MESSAGE:**

8/12/04

Motorola Corporation  
1303 E. Algonquin Road  
Schaumburg, IL 60196  
(847) 576-5000 Office

Dear Ms Cathy McMillian,

Thank you for reviewing the enclosed FAWN (Fuzzy Audio Wireless Music) headset proposal.

The FAWN is a convenient, hands-free headset with crisp and pristine sound with no peripheral interference. The headset can be used with but not limited to computers, portable CD/cassette players, portable MP3's and AM/FM radios.

Thank you for your time and I look forward to meeting with you to discuss this proposal in further detail. If you have any questions, my contact information is listed below.

Sincerely,

C. Earl Woolfork  
(818) 625-4966 Cell Phone  
(626) 792-9822 Home Phone  
[cwoolfork@sbcglobal.net](mailto:cwoolfork@sbcglobal.net)



# Fuzzy Audio Wireless Music (FAWM) (Patent Pending)

By

C. Earl Woolfork, Electrical Engineer

Phone: (818) 625-4966 or (626) 792-9822

e-mail: [cwoolfork@sbcglobal.net](mailto:cwoolfork@sbcglobal.net)

## DESCRIPTION

- WIRELESS HEADSET USED WITH THE FOLLOWING DEVICES  
(SEE FIGURE 1):
  - Portable MP3
  - Portable CD/Cassette Player
  - AM/FM Radio
  - Desktop/Laptop Computer

## FEATURES

- THE FAWM UTILIZES BLUETOOTH TECHNOLOGY
  - A battery powered digital transmitter plugs into any standard  
headphone jack and transmits **only** to the assigned battery powered  
digital headphone receiver.

8/12/04

4

- Multiple FAWM users can operate within the same spatial area without interfering with each other.

## **MARKET ANALYSIS**

### **• CURRENT WIRELESS AUDIO DEVICES:**

- Do not support multiple users
- Require A/C power
- Do not operate with portable devices

## **SUMMARY**

The FAWM device eliminates the inconvenience of wires, while connecting your portable audio device without degrading sound quality.

8/12/04

5

# Wireless Digital Audio

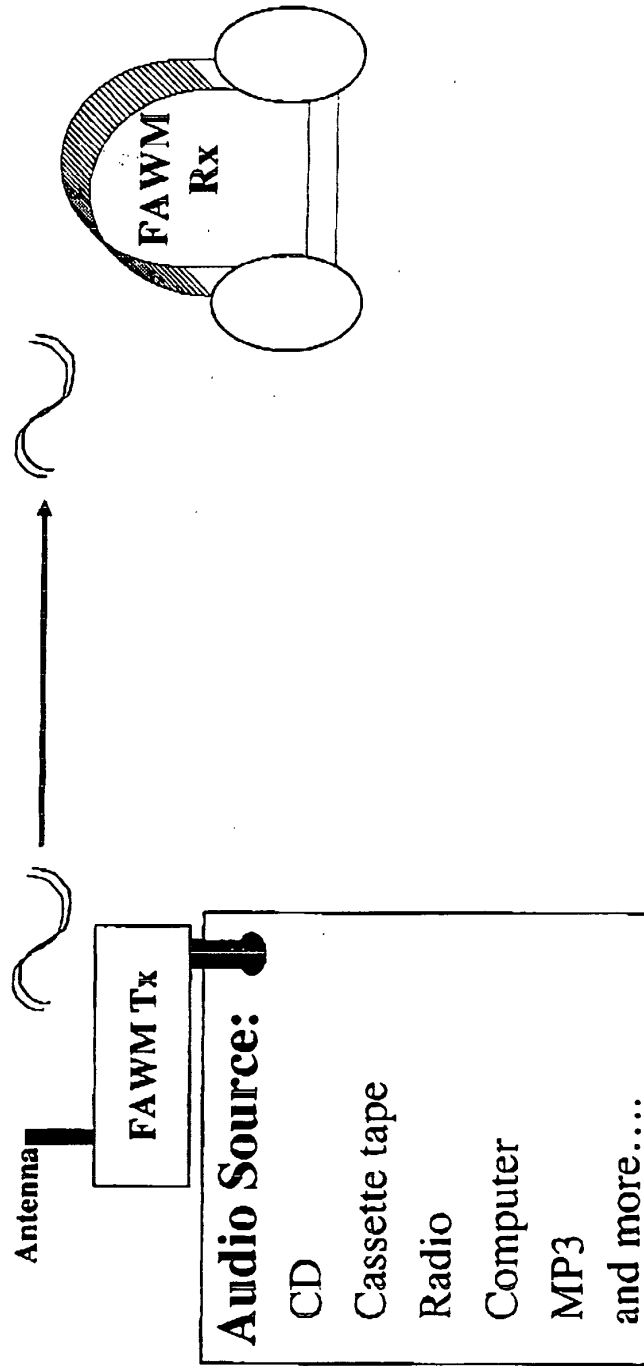

Figure 1

8/12/04

JOB STATUS REPORT

TIME : 08/12/2004 06:38  
NAME :  
FAX# :  
TEL# :

DATE, TIME	08/12 06:37
FAX NO./NAME	916172529685
DURATION	00:00:57
PAGE(S)	05
RESULT	OK
MODE	STANDARD ECM

[REDACTED]

TO: ANDREW RAMER

NAME: MOTOROLA      DATE: 8/12/04  
COMPANY  
TELEPHONE: (617) 252-9668      FAX: (617) 252-9685  
# OF PAGES (INCLUDING COVER) 5

FROM: C. EARL WOOLFORK

NAME: EARL WOOLFORK      ORG.  
BLOG / MS:  
TELEPHONE: (818) 625-4966      FAX: (310) 334-4717

MESSAGE:  
[REDACTED]

8/12/04

Motorola Corporation  
Cambridge, MA  
(617) 252-9668 Office

Dear Mr Andrew Ramer,

Thank you for reviewing the enclosed FAWN (Fuzzy Audio Wireless Music) headset proposal.

The FAWN is a convenient, hands-free headset with crisp and pristine sound with no peripheral interference. The headset can be used with but not limited to computers, portable CD/cassette players, portable MP3's and AM/FM radios.

Thank you for your time and I look forward to meeting with you to discuss this proposal in further detail. If you have any questions, my contact information is listed below.

Sincerely,

C. Earl Woolfork  
(818) 625-4966 Cell Phone  
(626) 792-9822 Home Phone  
[cwoolfork@sbcglobal.net](mailto:cwoolfork@sbcglobal.net)

JOB STATUS REPORT

TIME : 08/16/2004 11:17  
NAME :  
FAX# :  
TEL# :

DATE, TIME	08/16 11:16
FAX NO./NAME	918475763750
DURATION	00:00:32
PAGE(S)	02
RESULT	OK
MODE	STANDARD ECM







August 11, 2004

Earl Woolfork  
500 Santa Paula Ave.  
Pasadena, CA 91107

Re: Submission Idea

Dear Mr. Woolfork:

In response to your recent inquiry, enclosed please find two copies of Motorola's policy and agreement regarding submission of ideas by persons outside the company. Given the frequency with which we receive ideas from people, who are not our employees, we have established this policy to protect both the submitter of the idea and Motorola.

It is Motorola's policy to require each inventor to sign this agreement before we will evaluate ideas from outside the corporation. If you have already sent us information on your idea, please be assured that we do not review any such materials until we have received the signed agreement.

Please sign and return one copy of the agreement along with any information, including patent number if applicable, that you feel would assist us in determining whether we are interested in pursuing this matter with you. Be sure to retain a copy of any information you submit and a copy of the agreement as we will be unable to return these materials to you.

Thank you for considering Motorola for your submission.

Sincerely,

Motorola, Inc.  
External Relations  
Intellectual Property Section  
Law Department

**Corporate Offices**  
1303 East Algonquin Road, Schaumburg, IL 60196  
(847) 576-5184

2004-0470

12



Search

Home | About Motorola | Products and Services | Shop

- [Overview](#)
- [News Releases](#)
- [Media Contacts](#)
- [Executive Bios](#)
- [Media Info](#)
- [Graphix](#)
- [Personal Communications](#)
- [Exploring Technology:](#)
- [Multimedia News Releases](#)
- [Investors](#)
- [Industry Analysts](#)
- [Calendar](#)
- [Motorola® in 2005](#)

[Printer Friendly Version](#)

## Motorola Advances the Mobile Music Experience through Bluetooth

*New suite of Bluetooth wireless-enabled products merges wire-free mobility with musical entertainment*

LAS VEGAS, NV. – 8 January 2004 – Motorola Inc. (NYSE: MOT) forges new ground in mobile music with the announcement of the Motorola Bluetooth® Stereo Headset HT820, Motorola Bluetooth® Stereo Transceiver DC800 and Motorola Bluetooth® USB PC Adapter PC850. Designed for freedom, ease of use and seamless access to favorite songs, this trio creates a premium hi-fi wireless mobile music system.

As the first headset of its kind on the market, the Motorola HT820 wirelessly connects to a Bluetooth wireless-enabled phone and a separate music source simultaneously – promising that users can enjoy favorite songs without missing a call. Music automatically pauses when a call comes in and when the call ends, the music resumes play. The intuitive headset features controls for both the music source and mobile phone – making it easy to play, pause or stop a favorite song, as well as receive, answer or end calls wirelessly.

"Motorola continues to lead the industry with its development of innovative Bluetooth wireless-enabled handsets and accessories," said Bruce Hawver, vice president and general manager, Companion Products Group, Motorola, Personal Device Business. "Whether looking for an in-vehicle solution, headset, a wire-free music experience, consumers can rely on Motorola's Bluetooth portfolio for style, simplicity and advanced functionality."

Motorola's new trio of music-focused Bluetooth products eliminates the clutter of cables and provides Bluetooth connections for up to 10m (30 feet) – delivering flexible, high-quality, hands-free communication and entertainment.

### About the Products

The lightweight, ergonomic Motorola HT820 provides premium communication and music connectivity with minimized background noise and reliable battery power. Complete with a 3.5mm headset jack and accessory cable, the headset is compatible with non-Bluetooth devices for universal music enjoyment.

With the ability to turn most stereos into a wireless music system, the portable Motorola DC800 streams content to the Motorola HT820 from the stereo and Bluetooth wireless-enabled mobile phones, PCs or other devices. For group listening, music can be played through the stereo speakers.

The Motorola PC850 empowers traditional laptops and PCs with Bluetooth technology, establishing cordless connections to compatible mobile phones, headsets and PDAs. Whether used to share and stream music files, data or images, the PC adapter provides a new level of mobile convenience.

### Pricing and Availability

The Motorola Bluetooth Stereo Headset HT820, Motorola Bluetooth Stereo Transceiver DC800 and Motorola Bluetooth USB PC Adapter PC850 are expected to be available in the first half of 2005. For more information regarding product availability in your region, please check with your local Motorola representative.

### About Motorola

Motorola is a Fortune 100 global communications leader that provides seamless mobility products and solutions across broadband, embedded systems and wireless networks. In your home, auto, workplace, and all spaces in between, seamless

mobility means you can reach the people, things and information you need, on the go. Seamless mobility harnesses the power of technology convergence and enables smarter, faster, cost-effective and flexible communication. Motorola had sales of US \$27.1 billion in 2003. For more information: [www.motorola.com](http://www.motorola.com).

Digital imagery of Motorola Personal Device products mentioned in this release can be seen at: [www.Motorola.com/motoinfo](http://www.Motorola.com/motoinfo)

###

**Media Contact:**  
Monica Rohleder  
+1-847-523-5377  
[monica.rohleder@motorola.com](mailto:monica.rohleder@motorola.com).

MOTOROLA and the Stylized M Logo are registered in the US Patent & Trademark Office. All other product or service names are the property of their respective owners. The Bluetooth word mark and logos are owned by the Bluetooth SIG, Inc., and any use of such marks by Motorola, Inc. is under license. Other trademarks and trade names are those of their respective owners.

© Motorola, Inc. 2004.

---

<a href="http://www.motorola.com">www.motorola.com</a>		<a href="#">Terms of Use</a>		<a href="#">Privacy Practices</a>		<a href="#">Contact</a>		© Copyright 1994-2005 Motorola, Inc. All rights reserved.
--	--	------------------------------	--	-----------------------------------	--	-------------------------	--	---

---

Autoblog Most Popular: [Ford Mustang](#) (73 posts), [Chrysler 300C](#) (45), [Corvette C6](#) (39), [Mini Cooper](#) (37), [Toyota Prius](#) (37).

<p><b>Calculate Your Savings</b></p> <p>LEARN MORE</p>	<p>Enter your monthly phone bill and click the calculate button to find out.</p> <p><b>CALCULATE SAVINGS</b></p>	<p>See what you can save by switching your home phone service to <b>VONAGE</b>.</p>	<p><b>VONA</b> THE BARGAIN PHONE</p> <p>CHECK IT OUT</p>
--	--	---	--

# engadget

MY YAHOO! NEW

Have great gadge

Advertiser

## Motorola @ CES - The HT820 Bluetooth stereo headset explained

Posted Jan 8, 2005, 1:45 PM ET by Eric Lin  
Related entries: [Cellphones](#), [CES](#), [Portable Audio](#), [Wireless](#)

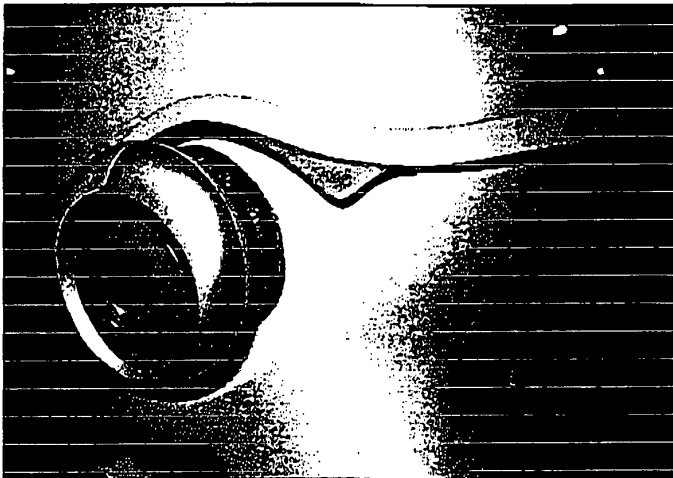

Yesterday we thought the [Moto Bluetooth stereo headset](#) was interesting but we hadn't seen it and couldn't quite explain it. Today we have all the answers. (Ok, maybe not *all* the answers.) Here's how it really works. The HT820 supports both headset and hands-free to connect to a phone via Bluetooth. It also supports two new Bluetooth profiles for audio, one for receiving stereo broadcast and the other for controlling audio devices. If you have an audio device that supports the profiles, or you have an adapter—either one of Motorola's that we mentioned or even the [naviPlay](#)—the

LUXURY TRAVEL AUCTION



SEARCH FOR TRIPS

LUXURY LINK  
Advertisement

Choo

Choo

SPC

The

H  
2000

W

Play  
all c  
So  
speci

A  
w

Make

<http://www.engadget.com/entry/1234000660026555/>

2/25/2005

15

headset will be able to pause your music when you take an incoming call, and you can even skip tracks using buttons right on the headset. If, however you don't have a Bluetooth audio device or adapter, you can plug a player into the phones using a cable, in which case, the HT820 will mute the audio when you get a phone call, but won't be able to pause it. There's a few more pix below.

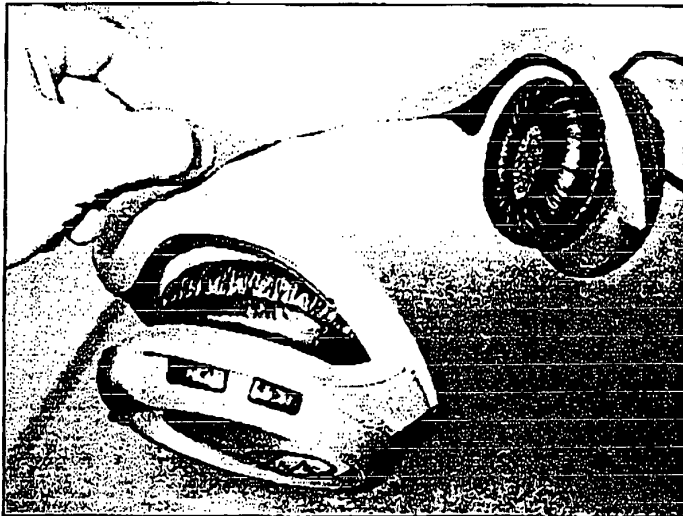
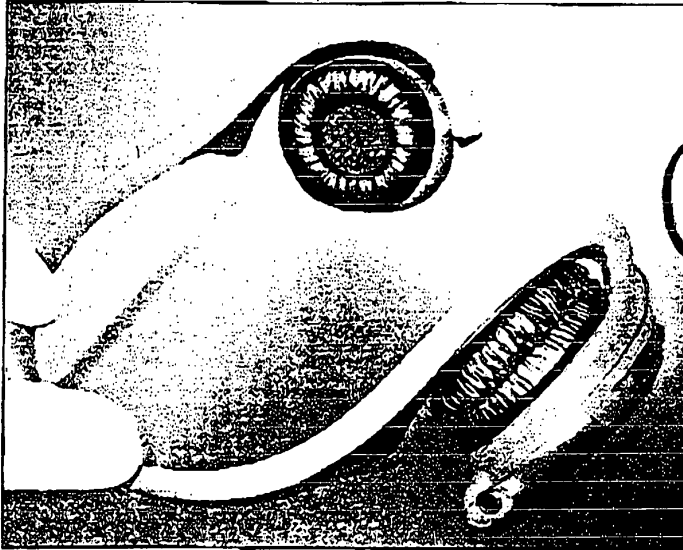

Permalink | Email this | Comments (15)

**Ads by Google** high-s  
 SmartPhoneDepot  
 Bluetooth  
 Accessories 20-  
 70% Off Headsets,  
 Handfree Car Kits  
 SmartPhoneDepot.Com

**Bluetooth headset**  
 Wireless  
 convenience, up to  
 7 hours talk time.  
 Compare prices  
 here!  
 www.logitech.com

**Bluetake**  
**BT420EX**  
 Bluetooth Stereo  
 Hi-Fi Headphones  
 MP3/PDA/Phone/PC  
 - Free Shipping  
 www.btboutique.com

**Bluetooth headset**  
**factory**  
 Stereo audio  
 headset, auto-  
 switch on When  
 receive call or  
 enjoy music.  
 www.ansso.com

**SECTIONS**

- Engadget Home
- Announcements
- Ask Engadget
- Cellphones
- Desktops
- Digital Cameras
- Displays
- Engadget
- Features
- Gaming
- GPS
- Handhelds
- HDTV
- Home Entertainment

<http://www.engadget.com/entry/123400066002655/>

2/25/2005

## Recent Entries

- » [Sony planning new PlayStation Portable with a 50GB hard drive?](#) (2/25/2005)
- » [The DIY Mac mini dock](#) (2/25/2005)
- » [Hasbro Tooth Tunes toothbrush makes you a loud mouth](#) (2/25/2005)
- » [Dell's new Inspiron 9300, their first Media Center Edition laptop](#) (2/25/2005)
- » [Sonos Digital Music System reviewed](#) (2/25/2005)

### Ads by Google

#### Bluetooth Stereo Headset

Find Wireless News, Product Info The Latest on Bluetooth Here  
wireless.eweek.com

#### Bluetooth Headset

Bluetrek G2 headset for any cell phone. Only \$44.99 Free S&H  
www.hakimov.com

#### Bluetooth headsets

Bluetooth headsets and accessories for cell phones - free shipping  
www.behandstree.com

#### Handheld Computers

Find, Compare and Buy PDAs! Shop and Save from 1000's of Stores  
www.Shopping.com

(Add your comments)

## Reader Comments

1. Posted Jan 8, 2005, 2:04 PM ET by Travis

Throwing in noise cancellation would put this product the stratosphere ... an in-car version of this combo and we'd be out in space. Good stuff!

2. Posted Jan 8, 2005, 2:12 PM ET by tree007

Man, it's about time something like this was produced. This and the iPhone could be a killer combination. I wonder what the audio quality is like though?

3. Posted Jan 8, 2005, 2:19 PM ET by Joey Geraci

and battery life. I don't see room for that big of a battery

4. Posted Jan 8, 2005, 2:33 PM ET by Adam

I want Caller ID via laser display to my lenses, HUD-style. Geez, get it right the first time and make a fortune.

<http://www.engadget.com/entry/1234000660026555/>

2/25/2005

- [Household Interviews](#)
- [Laptops](#)
- [Media PCs](#)
- [Misc. Gadgets](#)
- [Peripherals](#)
- [Podcasts](#)
- [Portable Audio](#)
- [Portable Video](#)
- [Robots](#)
- [Tablet PCs](#)
- [Transportation](#)
- [Wearables](#)
- [Wireless](#)

## RESOURCES

- [About Engadget](#)
- [Contact Us](#)
- [Advertise](#)
- [Corrections?](#)
- [Problems?](#)

## ENGADGET EMAIL

Sign Up

**Privacy:** Your email address will be used for Engadget news only. *We hate spam too.*

## RSS NEWSFEED

RSS 2.0

## LINK TO ENGADGET

ENGADGET

17

5. Posted Jan 8, 2005, 2:34 PM ET by Chris Heinonen

I want to know if there's a way I can get this to work for me at the office. Given how often I have to pause music and remove headphones when someone calls, if I could setup my desktop to support this, and somehow work with my phone, it would be ideal.

6. Posted Jan 8, 2005, 2:37 PM ET by Jaron Senna

Awesome if it will really work, battery life is my main concern...  
And, now all we need is a bluetooth module for the ipod I guess, although then we have a battery issue with the iPod if we haven't already...

7. Posted Jan 8, 2005, 2:53 PM ET by Scotto

Hmmm, no obvious microphone or boom attachment, how does it grab your voice when talking on the phone?

8. Posted Jan 8, 2005, 3:11 PM ET by Richard

Okay, so this supports both the Headset and Hands-Free profiles. Where's the mic at (so we can actually use this as a headset)? Also, what are the "new" audio profiles that it supports? I'm assuming Advanced Audio Distribution (A2DP) and Audio/Video Remote Control (AVRCP), but some confirmation and even more "deets" would be much appreciated. I'm excited to finally see a Bluetooth/wired stereo headset; this just may be close enough to that perfect device I was alluding to (<http://www.engadget.com/entry/5563682036957882/#e57818>)!

9. Posted Jan 8, 2005, 7:05 PM ET by Thomas

<http://www.bluctake.com/products/BT420EX.htm>

here is what you are looking for, has flip out mic there are no controls to skip tracks etc., but that would have to be made for a specific player I would think.

these are available now.

10. Posted Jan 8, 2005, 8:48 PM ET by Richard

I've known about that since Engadget posted on it. It's the closest thing currently available to what I want, but that's a Bluetooth only headset. Unlike this Motorola one, when the battery dies you are out of luck.

11. Posted Jan 8, 2005, 11:21 PM ET by jon

<http://www.engadget.com/entry/1234000660026555/>

ARCHIVES

- [Feb 2005](#)
- [Jan 2005](#)
- [Dec 2004](#)
- [Nov 2004](#)
- [Oct 2004](#)
- [Sep 2004](#)
- [Aug 2004](#)
- [Jul 2004](#)
- [Jun 2004](#)
- [May 2004](#)
- [Apr 2004](#)
- [Mar 2004](#)

Th  
E  
  
  
  
  
  
  
  
  
  
  
E  
  
  
  
  
  
  
  
  
  
  
Med  
  
  
  
  
  
  
  
  
  
  
E  
Dr  
I  
!

[Ads by Goooooogle](#)

**Bluespoon AX - Buy Now**

Smallest headset in the world - AX For Bluetooth available! Buy Here [www.bluespoons.com](http://www.bluespoons.com)

The  
SCV

**Jabra FreeSpeak Bluetooth**

Free Shipping on all models of Jabra Bluetooth FreeSpeak headsets [www.hitechwireless.com](http://www.hitechwireless.com)

T  
M

**Batteries & More**

Get \$500 for batteries absolutely free. [www.consumerincentives.com](http://www.consumerincentives.com)

B  
E

**Jabra FreeSpeak Headset**

For All Bluetooth Phones On Sale For Only \$69.98 [mobilecityonline.com](http://mobilecityonline.com)

2/25/2005

18

will there be an adapter so i can use it was a regular 3.5mm audio player? (i desperately want these for my gmini 400, v600. and ibm t42!!)

12. Posted Jan 10, 2005, 1:15 AM ET by Mike

As a Stereo Bluetooth Headset the SONORIX OBH-0100 is already on the market and does all of the above. With a totally wire free set of 'Sports' Bluetooth Stereo headphones it also boasts an 'on board' MP3 player too. It comes supplied with a USB Bluetooth dongle and Bluetooth Software Suite to enable the streaming of Stereo Audio from your PC too. It is also equipped with a mic and can be used as a mobile hands free kit pausing the music track you are listening to to take calls and fading it back in when you end your call .

Check out [www.bluesharksystems.com](http://www.bluesharksystems.com) for more details

13. Posted Jan 10, 2005, 2:29 AM ET by Mike

Mike,

Good point but the darn thing goes for \$239 US (In Canada that's like \$1000 dollars, eh?)

14. Posted Jan 10, 2005, 9:07 PM ET by Mike

I guess that does sound a bit steep, but I'm looking at these things from a regional perspective.

I live in the UK and if you break the Sonorix set down into its various components I think you are getting quite a bit of 'bang per buck'

eg.

The Sonorix OBH-0100 comprises of the following | (Wireless Studio Quality Stereo Audio Headset Sennheiser RS120 RRP £70) - (Top End (Mono) Bluetooth Hands free Headset Jabra RRP £59) - (128M/Bit Totally Wireless MP3 Player - Not even commercially available Disc-O Music Player nearest RRP £60) - (128M/Bit Compact Flash Ram File storage device RRP £25) - (Full Bluetooth Software Suite with USB Dongle - Belkin 10M RRP £25)---(Total RRP £239 GBP)|

That would equate to about \$448 USD at current rates. I know the cost of living is expensive in London but I guess these things are relative.

15. Posted Jan 11, 2005, 4:09 AM ET by Mike

I guess that does sound a bit steep, but I'm looking at these things from a regional perspective.

I live in the UK and if you break the Sonorix set down into its various components I think you are getting quite a bit of 'bang per buck'

<http://www.engadget.com/entry/1234000660026555/>

2/25/2005



eg.

The Sonorix OBH-0100 comprises of the following [ (Wireless Studio Quality Stereo Audio Headset Sennheiser RS120 RRP £70) - (Top End (Mono) Bluetooth Hands free Headset Jabra RRP £59) - (128M/Bit Totally Wireless MP3 Player - Not even commercially available Disc-O Music Player nearest RRP £60) - (128M/Bit Compact Flash Ram File storage device RRP £25) - (Full Bluetooth Software Suite with USB Dongle - Belkin 10M RRP £25)----(Total RRP £239 GBP)]

That would equate to about \$448 USD at current rates. I know the cost of living is expensive in London but I guess these things are relative.

## Add your comments

Please keep your comments relevant to this blog entry: inappropriate or purely promotional comments may be removed. Email addresses are never displayed, but they are required to confirm your comments. To create a live link, simply type the URL (including http://) or email address and we will make it a live link for you. You can put up to 3 URLs in your comments. Line breaks and paragraphs are automatically converted — no need to use <p> or <br> tags.

Your name (required):

Your email address (required, will not be shown to the public):

Your site's URL (optional):

http://

Do you want us to remember your personal information for next time?





Yes  No

Add your comments:

[Preview your comments](#)

[Add your comments](#)

All contents copyright © 2005, Engadget, LLC. All rights reserved.  
Engadget is a member of the Weblogs, Inc. Network. [Privacy Policy](#)

 <p><b>Calculate Your Savings</b> LEARN MORE</p>	 <p><b>CALCULATE SAVINGS</b></p>	 <p>Save what you earn Simply switching your home phone SERVICE TO: <b>VONAGE</b></p>	 <p><b>VONAGE</b> THE BUSINESS PHONE CHECK IT OUT</p>
---	---	---	--

Engadget is part of the Weblogs, Inc. Network — a network of more than 70 blogs.  
Here are some recent headlines from our other blogs:

**Autoblog**

Shoe is on the other foot - Automakers to invade Korea  
Dan Gillmor gets a Prius  
Opel dumps 4,500 jobs, halfway done  
A very different take on the Grand Cherokee  
About that BMW 1-Series sedan

**Joystiq (video games)**

Nintendo DS Download Service - Feb 26  
Is this the face of Xbox 2?  
Empire Earth 2 website comes to life  
Missing GT4 online? Try this.  
Troika closes

**Peer-to-Peer**

Ex-Loki Users Have Little to Fear  
A DNS system for file on P2P networks  
Earthstation 5 signs off the P2P airwaves  
UK downloaders avid for US TV content  
The "improved" iMesh update may soon be released

**Flash Insider**

Killer Sirius Player for Eminem  
Shockwave Flash  
This is Macy's?  
Skate It!  
Computer specs

**Luxist (fine living)**

More Uses for Burj Al Arab's Helipad  
Luxury Magazines On The Rise  
Visiting the Solid Gold Toilet  
The Osborne Family Gets Ripped Off Again  
Dranfield & Ross Birds of Paradise Tablecloth

**Blogging Baby**

Are you my mother?  
More contraction action  
Chill, pops... it's only a blunt  
It's Parent Appreciation Day!  
Cartoon characters pushing fatty foods on kids

**Wireless**

10,000 And Climbing  
SOCALWUG Meeting Tonight - Panel: Wireless in Business  
Sprint Intros International Wireless Device  
Were Pulse-Link's Actions Justified?  
Nitpicking On The BlackBerry

**TUAW (Apple)**

Working prototype: Mac mini car dock  
Google Maps now works in Safari  
No photos of photo connector for iPod  
Deny Apple considering TiVo buyout  
Griffin's Dock to FireWire 400

**hack a day**

homebrew mac mini dc  
hackaday links  
hacking a car horn  
howto: getting started v programming  
hackaday links

**Gadling (travel)**

Cooking in Florence  
More on Noise-Cancel  
Photo of the Day: (2/25  
Festival Finding  
Solo Traveling Not So

**Indie Film**

Can't Simone Simon G  
Oscar Predictions: Best  
Oscar's First Year at Fi  
The Day in Miramax: A  
Will Carry On  
UK Oddsmakers Close

**Engadget**

Sony planning new Pla  
50GB hard drive?  
The DIY Mac mini doc  
Hasbro Tooth Tunes to  
mouth  
Dell's new Inspiron 931  
Edition laptop  
Sonos Digital Music S5

If you want to advertise on the largest blog network in the world,  
email [Shawn Gold](mailto:Shawn.Gold) or call him at 310-828-8284.

News

Motorola bares its Bluetooth grin and points to the PMG

by Guy Kewney | posted on 18 October 2004

We had hints, before, that Motorola was following the IXI path, and designing a personal mobile gateway wireless hub - with phones, text pads, cameras and other toys all being Bluetooth peripherals. Now, the veil is lifting ... a family of new Bluetooth peripherals. And plans ... including stereo audio devices.



Today, the company said it couldn't confirm, but wouldn't deny, that it was working with Bluetooth pioneers IXI Mobile - then admitted that it would work with partners, and "wouldn't re-Invent wheels."

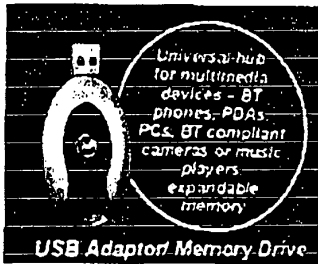

Music storage with both Bluetooth and USB

New toys: at a conference in London, product manager Fred Zimbric predicted that the phone itself would become

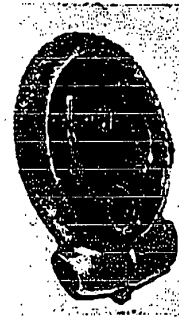

Bluetooth speaker for car hands-free

"just a little green circuit card." He said: "A phone will be embedded in cars, computers, other devices. The Bluetooth accessory will be the thing you use. You will wonder which is

the accessory, and which is the phone."

The star of the show was the "necklace" bluetooth device. There were also three ordinary wireless headpieces, and a "remote speaker" which allows the motorcar user to fit their own hands-free kit - all Bluetooth. "The HSB30 Necklace Headset will have a multifunction button, 5 hours talk time, six days standby. This is the bluetooth module; you can attach it to the motorcycle helmet headset in the HS 830 Helmet," said Zimbric, showing off the noise cancelling, rubber sealed cover, which makes the helmet unit weather proof.

Concept devices were shown. The necklace is a product which will definitely be launched, and will allow devices to be swapped out. But move away from phones, and devices being tested include texting keyboards "thin as a credit card, wearable like an ID badge" and music storage units, which could be used as a temporary "staging area" for high-res pictures taken by a future Bluetooth camera. Which might, or might not, be a phone itself.

"These are concept devices, not products," Zimbric said. "But if we did launch them, they would appear next year."

He also showed future Bluetooth toys; things which will allow us to take the sound output from iPods, TV sockets, or CD players or PCs, and literally broadcast them over Bluetooth throughout the home, in high quality stereo. Not, perhaps, true hi-fi - but then, the output of an iPod isn't true hi-fi, either.

Two devices in particular will appear soon. The DC800 Stereo Gateway; and HT 820 Bluetooth stereo headset "which we're coming out with next year, will be costed at a level well below WiFi stereo products, which we think are expensive. And we'll upgrade them as soon as the Bluetooth SIG (special interest group)

ratifies the Enhanced Data Rate (EDR) spec, which is three times faster than the 700 kilobit/sec payload you get today," said Fred Zimbric.

The uncanny resemblance between Motorola plans and IXI Mobile designs has been noted before. Was this the moment to ask whether the two companies were talking? Is this necklace the first step towards a Motorola PMG? or coincidence?

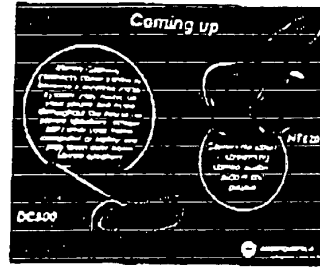

Henrik Asbjorn

Zimbric said he "couldn't say." Asked if he could deny it, he just grinned. Henrik Asbjorn, general manager of

**Future stereo Bluetooth products, for first quarter 05**

Motorola EMEA consumer business said: "Our relationship with Apple over iTunes shows that if there is something out there, then, if the question is 'are we going to reinvent everything?' then the answer is 'absolutely not.' The Apple Motorola deal made sense; will see where we can be partnering up with other companies, where it makes sense."

No comment from IXI Mobile, either.

Nice toys, Motorola. Which of them will be the PMG? - You can discuss this article on our [discussion board](#).

**Point your IRC client at [hunkymouse.co.uk](http://hunkymouse.co.uk), join channel #kewney, and flame us direct!**

Other comments? Feedback? Call me on +44 20 8809 0492 in the UK

# Press Release: Motorola Advances the Mobile Music Experience through Bluetooth



The Broadband Phone Company

Feature-filled calling plans  
from only



- [Home](#)
- [Search](#)
- [Forums](#)
- [Links](#)
- [Archives](#)
  - [Bluetooth](#)
  - [Columns](#)
  - [Galleries](#)
  - [News](#)
  - [Previews](#)
  - [Press Releases](#)
  - [Reviews](#)
  - [Rumors](#)
- [About](#)
- [PDA Version](#)
- [RSS](#)

Search:

## Phone Browser

- [Sony Ericsson](#)
- [Siemens](#)
- [Samsung](#)
- [Nokia](#)
- [Motorola](#)
- [LG](#)
- [All Brands](#)

**POLL:** *Do you own a regular digital camera?*

- Yes
- No

<http://www.mobileburn.com/pressrelease.isp?Id=1047&source=SEARCH>

2/25/2005

24

○ I plan to soon

Vote!

- **NEWS**  
RSS and Image Viewer for Java Phones

- **NEWS**  
Java MobileATM's Launch in UK



- **NEWS**  
GSL Xplore M68



- **GALLERY**  
Siemens SF65



- **NEWS**  
Samsung Anna Sui SGH-E315



- **NEWS**  
Sanyo MM-5600



- **GALLERY**  
Fujitsu F90iC



- **SNAPSHOT**  
Motorola A101Q



- **NEWS**  
Tegic Announces Plans Beyond T9



- **GALLERY**  
Motorola SLVR V8



- **COLUMN**  
A Chat With PalmSource

-  NEWS  
Sendo X2
-  NEWS  
Panasonic X800

[More in the Archives »](#)

## Motorola Advances the Mobile Music Experience through Bluetooth

Press Release posted by *Michael Oryl (editor)* on Thursday January 06, 2005.

Note: Sponsored advertising links, if any, are in green.

**New suite of Bluetooth wireless-enabled products merges wire-free mobility with musical entertainment**

LAS VEGAS, Jan. 6 /PRNewswire-FirstCall/ -- Motorola Inc. (NYSE:MOT) forges new ground in mobile music with the announcement of the Motorola Bluetooth(R) Stereo Headset HT820, Motorola Bluetooth(R) Stereo Transceiver DC800 and Motorola Bluetooth(R) USB PC Adapter PC850. Designed for freedom, ease of use and seamless access to favorite songs, this trio creates a premium hi-fi wireless mobile music system.

As the first headset of its kind on the market, the Motorola HT820 wirelessly connects to a Bluetooth wireless-enabled phone and a separate music source simultaneously -- promising that users can enjoy favorite songs without missing a call. Music automatically pauses when a call comes in and when the call ends, the music resumes play. The intuitive headset features controls for both the music source and mobile phone -- making it easy to play, pause or stop a favorite song, as well as receive, answer or end calls wirelessly.

"Motorola continues to lead the industry with its development of innovative Bluetooth wireless-enabled handsets and accessories," said Bruce Hawver, vice president and general manager, Companion Products Group, Motorola, Personal Device Business. "Whether looking for an in-vehicle solution, headset, a wire-free music experience, consumers can rely on Motorola's Bluetooth portfolio for style, simplicity and advanced functionality."

Motorola's new trio of music-focused Bluetooth products eliminates the clutter of cables and provides Bluetooth connections for up to 10m (30 feet) -- delivering flexible, high-quality, hands-free communication and entertainment.



The Broadband Phone Company

**\$24.99**  
month

**UNLIMITED CALLS**  
to all 50 states and Canada,  
anytime.

»

<http://www.mobileburn.com/pressrelease.jsp?Id=1047&source=SEARCH>

01/06/05

**About the Products**

The lightweight, ergonomic Motorola HT820 provides premium communication and music connectivity with minimized background noise and reliable battery power. Complete with a 3.5mm headset jack and accessory cable, the headset is compatible with non-Bluetooth devices for universal music enjoyment.

With the ability to turn most stereos into a wireless music system, the portable Motorola DC800 streams content to the Motorola HT820 from the stereo and Bluetooth wireless-enabled mobile phones, PCs or other devices. For group listening, music can be played through the stereo speakers.

The Motorola PC850 empowers traditional laptops and PCs with Bluetooth technology, establishing cordless connections to compatible mobile phones, headsets and PDAs. Whether used to share and stream music files, data or images, the PC adapter provides a new level of mobile convenience.

**Pricing and Availability**

The Motorola Bluetooth Stereo Headset HT820, Motorola Bluetooth Stereo Transceiver DC800 and Motorola Bluetooth USB PC Adapter PC850 are expected to be available in the first half of 2005. For more information regarding product availability in your region, please check with your local Motorola representative.

**About Motorola**

Motorola is a Fortune 100 global communications leader that provides seamless mobility products and solutions across broadband, embedded systems and wireless networks. In your home, auto, workplace, and all spaces in between, seamless mobility means you can reach the people, things and information you need, on the go. Seamless mobility harnesses the power of technology convergence and enables smarter, faster, cost-effective and flexible communication. Motorola had sales of US \$27.1 billion in 2003. For more information: <http://www.motorola.com/>.



The Granddaddy  
Phone-Company

**Add a second  
phone line  
for just  
\$14.99/mo.**

**Friends/Affiliates:**  
[BargainOffers.com](http://BargainOffers.com)  
[MobyMemory.com](http://MobyMemory.com)  
[Mobile9.com](http://Mobile9.com)  
[Zedge.net](http://Zedge.net)  
[DigitalCameraInfo](http://DigitalCameraInfo)  
[Club SonyEricsson](http://Club SonyEricsson)  
[PriceGrabber.Com](http://PriceGrabber.Com)

<http://www.mobileburn.com/pressrelease.jsp?Id=1047&source=SEARCH>

7/25/2005

28

**BLUETOOTH WIRELESS TECHNOLOGY**

**but in the WORLD**

<p><b>SONY</b></p> <p>Bluetooth Wireless Technology</p> <p>2001-2002</p> <p>www.sony.com</p>	<p><b>SONY</b></p> <p>Bluetooth Wireless Technology</p> <p>2001-2002</p> <p>www.sony.com</p>	<p><b>SONY</b></p> <p>Bluetooth Wireless Technology</p> <p>2001-2002</p> <p>www.sony.com</p>	<p><b>SONY</b></p> <p>Bluetooth Wireless Technology</p> <p>2001-2002</p> <p>www.sony.com</p>	<p><b>SONY</b></p> <p>Bluetooth Wireless Technology</p> <p>2001-2002</p> <p>www.sony.com</p>	<p><b>SONY</b></p> <p>Bluetooth Wireless Technology</p> <p>2001-2002</p> <p>www.sony.com</p>
--	--	--	--	--	--

**BLUETOOTH™ WIRELESS TECHNOLOGY**



Apple	BlackBerry	Motorola
HP	HTC	Nokia
IBM	LG	Sony
Intel	Lenovo	Toshiba
Microsoft	Philips	Verizon
Samsung	Sony	
Sony		
Toshiba		
Verizon		
Walmart		

**Out in the WORLD**

**This Page is Inserted by IFW Indexing and Scanning  
Operations and is not part of the Official Record**

**BEST AVAILABLE IMAGES**

Defective images within this document are accurate representations of the original documents submitted by the applicant.

Defects in the images include but are not limited to the items checked:

- BLACK BORDERS
- IMAGE CUT OFF AT TOP, BOTTOM OR SIDES
- FADED TEXT OR DRAWING
- BLURRED OR ILLEGIBLE TEXT OR DRAWING
- SKEWED/SLANTED IMAGES
- COLOR OR BLACK AND WHITE PHOTOGRAPHS
- GRAY SCALE DOCUMENTS
- LINES OR MARKS ON ORIGINAL DOCUMENT
- REFERENCE(S) OR EXHIBIT(S) SUBMITTED ARE POOR QUALITY
- OTHER: \_\_\_\_\_

**IMAGES ARE BEST AVAILABLE COPY.**

**As rescanning these documents will not correct the image problems checked, please do not report these problems to the IFW Image Problem Mailbox.**



IN THE UNITED STATES PATENT AND TRADEMARK OFFICE

Re: regards to application of:

Serial Number: 10/648,012  
Applicant: C. Earl Woolfork  
Filing Date: 08/26/2003  
Title: WIRELESS DIGITAL AUDIO SYSTEM  
TC/AU: 2644  
Examiner: Graham, Andrew R.

Mail Stop Non-Fee Amendment  
Commissioner for Patents  
P.O. Box 1450  
Alexandria, VA 22313-1450

-----  
**EXPRESS MAIL CERTIFICATE MAILING UNDER 37 CFR § 1.10**

"Express Mail" label number:

Date of Deposit:

I hereby certify that the following attached correspondence comprising:

19 Pages of response  
3 Drawing Sheets  
1 Page Information Disclosure Statement w/ 22 Pages  
2 Pages Declaration Under 37 CFR 1.132 w/ 30 Pages

is being deposited with the United States Postal Service "Express Mail Post Office to Addressee" service under 37 CFR § 1.10 on the date indicated above and is addressed to:

Mail Stop Non-Fee Amendment  
Commissioner for Patents  
P.O. Box 1450  
Alexandria, VA 22313-1450

Date: 7-1-05

  
ANNEROSE BEECH

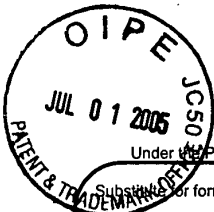

PTO/SB/08B (08-03)  
 Approved for use through 07/31/2006. OMB 0651-0031  
 U.S. Patent and Trademark Office; U.S. DEPARTMENT OF COMMERCE

Under the Paperwork Reduction Act of 1995, no persons are required to respond to a collection of information unless it contains a valid OMB control number.

<b>INFORMATION DISCLOSURE STATEMENT BY APPLICANT</b>  (Use as many sheets as necessary)	<b>Complete if Known</b>	
	Application Number	10/648,012
	Filing Date	08-26-2003
	First Named Inventor	C. Earl Woolfork
	Art Unit	2644
	Examiner Name	Graham, Andrew R.
Sheet 1 of 1	Attorney Docket Number	None

NON PATENT LITERATURE DOCUMENTS			
Examiner Initials*	Cite No. <sup>1</sup>	Include name of the author (in CAPITAL LETTERS), title of the article (when appropriate), title of the item (book, magazine, journal, serial, symposium, catalog, etc.), date, page(s), volume-issue number(s), publisher, city and/or country where published.	T <sup>2</sup>
		"Digital Communication Techniques" by Simon, Hinedi and Lindsey	
		"Wireless Communications" by Rappaport	
		"Communication Networks" by Walrand	
		"Unified Analysis of Certain Coherent and Noncoherent Binary Communications Systems" by Stein in IEEE Transactions on Information Theory, January 1964	

Examiner Signature	Date Considered
--------------------	-----------------

\*EXAMINER: Initial if reference considered, whether or not citation is in conformance with MPEP 609. Draw line through citation if not in conformance and not considered. Include copy of this form with next communication to applicant.  
<sup>1</sup> Applicant's unique citation designation number (optional). <sup>2</sup> Applicant is to place a check mark here if English language Translation is attached.  
 This collection of information is required by 37 CFR 1.98. The information is required to obtain or retain a benefit by the public which is to file (and by the USPTO to process) an application. Confidentiality is governed by 35 U.S.C. 122 and 37 CFR 1.14. This collection is estimated to take 2 hours to complete, including gathering, preparing, and submitting the completed application form to the USPTO. Time will vary depending upon the individual case. Any comments on the amount of time you require to complete this form and/or suggestions for reducing this burden, should be sent to the Chief Information Officer, U.S. Patent and Trademark Office, P.O. Box 1450, Alexandria, VA 22313-1450. DO NOT SEND FEES OR COMPLETED FORMS TO THIS ADDRESS. SEND TO: Commissioner for Patents, P.O. Box 1450, Alexandria, VA 22313-1450.

If you need assistance in completing the form, call 1-800-PTO-9199 (1-800-786-9199) and select option 2.

**PATENT APPLICATION FEE DETERMINATION RECORD**  
Effective January 1, 2003

Application or Docket Number

10/649012

**CLAIMS AS FILED - PART I**

	(Column 1)	(Column 2)
TOTAL CLAIMS	5	
FOR	NUMBER FILED	NUMBER EXTRA
TOTAL CHARGEABLE CLAIMS	5 minus 20 =	0
INDEPENDENT CLAIMS	3 minus 3 =	0
MULTIPLE DEPENDENT CLAIM PRESENT	<input type="checkbox"/>	

\* If the difference in column 1 is less than zero, enter "0" in column 2

**CLAIMS AS AMENDED - PART II**

2/25/05

	(Column 1)	(Column 2)	(Column 3)
AMENDMENT A	CLAIMS REMAINING AFTER AMENDMENT	HIGHEST NUMBER PREVIOUSLY PAID FOR	PRESENT EXTRA
Total	5	20	0
Independent	3	3	0
FIRST PRESENTATION OF MULTIPLE DEPENDENT CLAIM	<input type="checkbox"/>		

7/1/05

	(Column 1)	(Column 2)	(Column 3)
AMENDMENT B	CLAIMS REMAINING AFTER AMENDMENT	HIGHEST NUMBER PREVIOUSLY PAID FOR	PRESENT EXTRA
Total	4	20	0
Independent	4	3	1
FIRST PRESENTATION OF MULTIPLE DEPENDENT CLAIM	<input type="checkbox"/>		

	(Column 1)	(Column 2)	(Column 3)
AMENDMENT C	CLAIMS REMAINING AFTER AMENDMENT	HIGHEST NUMBER PREVIOUSLY PAID FOR	PRESENT EXTRA
Total			
Independent			
FIRST PRESENTATION OF MULTIPLE DEPENDENT CLAIM	<input type="checkbox"/>		

\* If the entry in column 1 is less than the entry in column 2, enter "0" in column 3.  
 \*\* If the "Highest Number Previously Paid For" IN THIS SPACE is less than 20, enter "20."  
 \*\*\* If the "Highest Number Previously Paid For" IN THIS SPACE is less than 3, enter "3."  
 The "Highest Number Previously Paid For" (Total or Independent) is the highest number found in the appropriate box in column 1.

SMALL ENTITY TYPE  OR OTHER THAN SMALL ENTITY

RATE	FEE	OR	RATE	FEE
BASIC FEE	375.00	OR	BASIC FEE	750.00
X\$ 9=		OR	X\$18=	
X42=		OR	X84=	
+140=		OR	+280=	
TOTAL	375	OR	TOTAL	

SMALL ENTITY OR OTHER THAN SMALL ENTITY

RATE	ADDITIONAL FEE	OR	RATE	ADDITIONAL FEE
X\$ 9=		OR	X\$18=	
X42=		OR	X84=	
+140=		OR	+280=	
TOTAL ADDIT. FEE		OR	TOTAL ADDIT. FEE	

RATE	ADDITIONAL FEE	OR	RATE	ADDITIONAL FEE
X\$ 9=		OR	X\$18=	
X42=		OR	X84=	
+140=		OR	+280=	
TOTAL ADDIT. FEE		OR	TOTAL ADDIT. FEE	

RATE	ADDITIONAL FEE	OR	RATE	ADDITIONAL FEE
X\$ 9=		OR	X\$18=	
X42=		OR	X84=	
+140=		OR	+280=	
TOTAL ADDIT. FEE		OR	TOTAL ADDIT. FEE	

Best Available Copy

Customer No. 33401

**RECEIVED** Attorney Docket No. 73785-014  
**CENTRAL FAX CENTER**

JUL 25 2005

PATENT

**IN THE UNITED STATES PATENT AND TRADEMARK OFFICE**

In re Application of:  
C. Earl Woolfork

Serial No.: 10/648,012

Filed: August 26, 2003

For: WIRELESS DIGITAL  
AUDIO SYSTEM

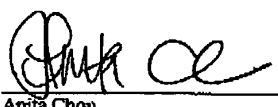
<p>CERTIFICATE OF FACSIMILE TRANSMISSION UNDER 37 C.F.R. § 1.6(d)</p> <p>I hereby certify that this correspondence is being transmitted via facsimile to 571-273-8300 under 37 CFR 1.6(d) on the July 27, 2005..</p>  <p>Anita Chou</p>
---

Commissioner for Patents  
P.O. Box 1450  
Alexandria, VA 22313-1450

**REVOCATION OF POWER OF ATTORNEY AND NEW APPOINTMENT**

Sir:

Applicant revokes all previous powers of attorney to Dennis W. Beech and the Law Offices of Dennis W. Beech, and now appoints the registered practitioners of the law firm McDermott Will & Emery LLP, included in the Customer Number provided below, with full power of substitution and revocation, to prosecute this application and any continuation, divisional, continuation-in-part, reissue, or reexam application thereof, and any international application under the Patent Cooperation Treaty based on it, and to transact all business in the U.S. Patent and Trademark Office connected therewith.

**CUSTOMER NUMBER 33401**

Applicant hereby grants said attorneys the power to insert on this Power of Attorney any further identification that may be necessary or desirable in order to comply with the rules of the U.S. Patent and Trademark Office and before competent International Authorities including the World Intellectual Property Organization..

The authority under this Power of Attorney of each person named above shall automatically terminate and be revoked upon such person ceasing to be a member or associate of or of counsel to that law firm.

Please direct all future correspondence to:

ATTN: Daphne L. Burton  
MCDERMOTT, WILL & EMERY, LLP  
2049 Century Park East, 34th Floor  
Los Angeles, California 90067



Attorney Docket No. 73785-014

Telephone: 310.277.4110

I declare that all statements made herein of my own knowledge are true, and that all statements made on information and belief are believed to be true. I make these statements with the knowledge that willful false statements and the like so made are punishable by fine or imprisonment, or both, under 18 U.S.C. § 1001, and that such willful false statements may jeopardize the validity of the application or any patent issuing from the application.

C. Earl Woolfork

Date:

7/20/05

By

  
C. Earl Woolfork

Customer No. 33401

Attorney Docket No. 073758-0013

**PATENT RECEIVED  
CENTRAL FAX CENTER**

**IN THE UNITED STATES PATENT AND TRADEMARK OFFICE**

**JUL 26 2005**

In re Application of:  
C. Earl Woolfork

Group Art Unit: 2644

Serial No.: 10/648,012

Examiner: Andrew R. Graham

Filed: August 26, 2003

For: WIRELESS DIGITAL AUDIO  
SYSTEM

**CERTIFICATE OF FACSIMILE TRANSMISSION UNDER 37 C.F.R. § 1.6(d)**

I hereby certify that this correspondence is being transmitted via facsimile to 571-273-8300 under 37 CFR 1.6(d) on the date below.

Date: 7/20/05

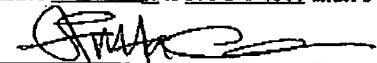
  
Anita Chou

Commissioner of Patents  
P.O. Box 1450  
Alexandria, VA 22313-1450

**NOTICE OF APPEAL FROM THE PRIMARY EXAMINER  
TO THE BOARD OF APPEALS**

Applicant hereby appeals to the Board from the decision of the Primary Examiner mailed May 18, 2005, rejecting claims 1-5. An amendment was filed in response to this action on or about July 1, 2005. The amendment has been entered. The amendment cancels claims 2, 3 and 5, and adds claims 6 and 7. The amended claims are those which Applicant wishes to appeal. Accordingly, the present appeal pertains to Claims 1, 4, 6 and 7.

This appeal is being presented because various claims of the present application have been rejected on at least three occasions. The present application has been rejected once. The present application is a continuation-in-part of U.S. patent application serial no. 10/027,391. This parent application was rejected twice.

LAS99 1412492-1.073785.0013

07/28/2005 WARDLRI 00000123 501946 10648012  
01 FC:2401 250.00 DA

Serial No.: 10/648,012

Attorney Docket No.: 073758-0013

The items checked below are appropriate:

**STATUS OF APPLICANT**

This application is on behalf of:

other than a small entity

small entity

**FEE FOR FILING NOTICE OF APPEAL**

Pursuant to 37 C.F.R. § 1.17(e) the fee for filing the Notice of Appeal is:

small entity \$250.00

other than a small entity \$500.00

Notice of Appeal fee due \$250.00

Applicant believes that no extension of term is required. However, this conditional petition is being made to provide for the possibility that applicant has inadvertently overlooked the need for a petition and fee for extension of time.

**TOTAL FEE DUE**

The total fee due is:

Notice of Appeal fee \$250.00

**TOTAL FEE DUE \$250.00**

**FEE PAYMENT**

Charge Account No. 50-1946 the sum of \$ 250.00. A duplicate of this transmittal is attached.

**FEE DEFICIENCY**

Please charge any additional fees which may be required, or credit overpayment to Deposit Account No. 50-1946.

Serial No.: 10/648,012

Attorney Docket No.: 073758-0013

Respectfully submitted,

July 26, 2005  
Date

Daphne L. Burton  
Daphne L. Burton  
Registration No. 45,323

MCDERMOTT WILL & EMERY LLP  
2049 Century Park East, 34th Floor  
Los Angeles, CA 90067  
Telephone: (310) 277-4110  
Facsimile: (310) 277-4730

Customer No. 33401

Attorney Docket No. 073758-0013

IN THE UNITED STATES PATENT AND TRADEMARK OFFICE

PATENT RECEIVED  
CENTRAL FAX CENTER

JUL 26 2005

In re Application of:  
C. Earl Woolfork

Group Art Unit: 2644

Serial No.: 10/648,012

Examiner: Andrew R. Graham

Filed: August 26, 2003

For: WIRELESS DIGITAL AUDIO  
SYSTEM

**CERTIFICATE OF FACSIMILE TRANSMISSION UNDER 37 C.F.R. § 1.6(d)**

I hereby certify that this correspondence is being transmitted via facsimile to 571-273-8300 under 37 CFR 1.6(d) on the date below.

Date: 7/20/05

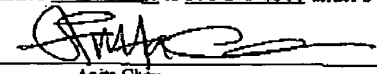
  
Anita Chou

Commissioner of Patents  
P.O. Box 1450  
Alexandria, VA 22313-1450

**NOTICE OF APPEAL FROM THE PRIMARY EXAMINER  
TO THE BOARD OF APPEALS**

Applicant hereby appeals to the Board from the decision of the Primary Examiner mailed May 18, 2005, rejecting claims 1-5. An amendment was filed in response to this action on or about July 1, 2005. The amendment has been entered. The amendment cancels claims 2, 3 and 5, and adds claims 6 and 7. The amended claims are those which Applicant wishes to appeal. Accordingly, the present appeal pertains to Claims 1, 4, 6 and 7.

This appeal is being presented because various claims of the present application have been rejected on at least three occasions. The present application has been rejected once. The present application is a continuation-in-part of U.S. patent application serial no. 10/027,391. This parent application was rejected twice.

LAS99 1412492-1.073785.0013

07/28/2005 WARDLRI 00000123 501946 10648012  
01 FC:2401 250.00 DA

Serial No.: 10/648,012

Attorney Docket No.: 073758-0013

The items checked below are appropriate:

**STATUS OF APPLICANT**

This application is on behalf of:

- other than a small entity
- small entity

**FEE FOR FILING NOTICE OF APPEAL**

Pursuant to 37 C.F.R. § 1.17(e) the fee for filing the Notice of Appeal is:

- small entity \$250.00
- other than a small entity \$500.00
- Notice of Appeal fee due \$250.00

Applicant believes that no extension of term is required. However, this conditional petition is being made to provide for the possibility that applicant has inadvertently overlooked the need for a petition and fee for extension of time.

**TOTAL FEE DUE**

The total fee due is:

Notice of Appeal fee \$250.00

**TOTAL FEE DUE \$250.00**

**FEE PAYMENT**

Charge Account No. 50-1946 the sum of \$ 250.00. A duplicate of this transmittal is attached.

**FEE DEFICIENCY**

Please charge any additional fees which may be required, or credit overpayment to Deposit Account No. 50-1946.

Serial No.: 10/648,012

Attorney Docket No.: 073758-0013

Respectfully submitted,

July 26, 2005  
Date

Daphne L. Burton  
Daphne L. Burton  
Registration No. 45,323

MCDERMOTT WILL & EMERY LLP  
2049 Century Park East, 34th Floor  
Los Angeles, CA 90067  
Telephone: (310) 277-4110  
Facsimile: (310) 277-4730



UNITED STATES PATENT AND TRADEMARK OFFICE

UNITED STATES DEPARTMENT OF COMMERCE  
United States Patent and Trademark Office  
Address: COMMISSIONER FOR PATENTS  
P.O. Box 1450  
Alexandria, Virginia 22313-1450  
www.uspto.gov

APPLICATION NUMBER	FILING OR 371 (c) DATE	FIRST NAMED APPLICANT	ATTY. DOCKET NO./TITLE
10/648,012	08/26/2003	C. Earl Woolfork	73785-014

ATTN: Daphne L. Burton  
McDERMOTT, WILL & EMERY, LLP  
34th Floor  
2049 Century Park East  
Los Angeles, CA 90067

CONFIRMATION NO. 3337



\*OC000000016730504\*

Date Mailed: 08/09/2005

**NOTICE OF ACCEPTANCE OF POWER OF ATTORNEY**

This is in response to the Power of Attorney filed 07/25/2005.

The Power of Attorney in this application is accepted. Correspondence in this application will be mailed to the above address as provided by 37 CFR 1.33.

KIDIST TESFAYE  
PTOSS Q-

OFFICE COPY





UNITED STATES PATENT AND TRADEMARK OFFICE

UNITED STATES DEPARTMENT OF COMMERCE  
United States Patent and Trademark Office  
Address: COMMISSIONER FOR PATENTS  
P.O. Box 1450  
Alexandria, Virginia 22313-1450  
www.uspto.gov

APPLICATION NUMBER	FILING OR 371 (c) DATE	FIRST NAMED APPLICANT	ATTY. DOCKET NO./TITLE
10/648,012	08/26/2003	C. Earl Woolfork	

42794  
DENNIS W. BEECH (LAW OFFICE OF DENNIS W. BEECH)  
P.O. BOX 519  
MURRIETA, CA 92564-0519

CONFIRMATION NO. 3337



\*OC000000016730406\*

Date Mailed: 08/09/2005

NOTICE REGARDING CHANGE OF POWER OF ATTORNEY

This is in response to the Power of Attorney filed 07/25/2005.

- The Power of Attorney to you in this application has been revoked by the applicant. Future correspondence will be mailed to the new address of record(37 CFR 1.33).

KIDIST TESFAYE  
PTOSS 0-

OFFICE COPY

By



UNITED STATES PATENT AND TRADEMARK OFFICE

UNITED STATES DEPARTMENT OF COMMERCE  
United States Patent and Trademark Office  
Address: COMMISSIONER FOR PATENTS  
P.O. Box 1450  
Alexandria, Virginia 22313-1450  
www.uspto.gov

APPLICATION NO.	FILING DATE	FIRST NAMED INVENTOR	ATTORNEY DOCKET NO.	CONFIRMATION NO.
10/648,012	08/26/2003	C. Earl Woolfork	73785-014	3337

7590 08/16/2005  
ATTN: Daphne L. Burton  
McDERMOTT, WILL & EMERY, LLP  
34th Floor  
2049 Century Park East  
Los Angeles, CA 90067

EXAMINER

GRAHAM, ANDREW R

ART UNIT	PAPER NUMBER
2644	

2644

DATE MAILED: 08/16/2005

Please find below and/or attached an Office communication concerning this application or proceeding.

<b>Communication Re: Appeal</b>	Application No.	Applicant(s)	
	10/648,012	WOOLFORK, C. EARL	
	Examiner	Art Unit	
	Andrew Graham	2644	

-- The MAILING DATE of this communication appears on the cover sheet with the correspondence address --

1.  The Notice of Appeal filed on 26 July 2005 is not acceptable because:
- (a)  it was not timely filed.
  - (b)  the statutory fee for filing the appeal was not submitted. See 37 CFR 41.20(b)(1).
  - (c)  the appeal fee received on \_\_\_\_\_ was not timely filed.
  - (d)  the submitted fee of \$\_\_\_\_\_ is insufficient. The appeal fee required by 37 CFR 41.20(b)(1) is \$\_\_\_\_\_.
  - (e)  the appeal is not in compliance with 37 CFR 41.31(a)(1) in that no claim has been twice rejected.
  - (f)  a Notice of Allowability, PTO-37, was mailed by the Office on \_\_\_\_\_.

2.  The appeal brief filed on \_\_\_\_\_ is NOT acceptable for the reason(s) indicated below:
- (a)  the brief and/or brief fee is untimely. See 37 CFR 41.37(a).
  - (b)  the statutory fee for filing the brief has not been submitted. See 37 CFR 41.20(b)(2).
  - (c)  the submitted brief fee of \$\_\_\_\_\_ is insufficient. The brief fee required by 37 CFR 41.20(b)(2) is \$\_\_\_\_\_.

**The appeal in this application will be dismissed unless corrective action is taken to timely submit the brief and requisite fee. See 37 CFR 41.37(a)(1). Extensions of time may be obtained under 37 CFR 1.136(a). See 37 CFR 41.37(e).**

3.  The appeal in this application is DISMISSED because:
- (a)  the statutory fee for filing the brief as required under 37 CFR 41.20(b)(2) was not timely submitted and the period for obtaining an extension of time to file the brief under 37 CFR 1.136(a) has expired.
  - (b)  the brief was not timely filed and the period for obtaining an extension of time to file the brief under 37 CFR 1.136(a) has expired.
  - (c)  a Request for Continued Examination (RCE) under 37 CFR 1.114 was filed on \_\_\_\_\_.
  - (d)  other: \_\_\_\_\_.

4.  Because of the dismissal of the appeal, this application:
- (a)  is abandoned because there are no allowed claims.
  - (b)  is before the examiner for final disposition because it contains allowed claims. Prosecution on the merits remains CLOSED.
  - (c)  is before the examiner for consideration.

  
**VIVIAN CHIN**  
**SUPERVISORY PATENT EXAMINER**  
**TECHNOLOGY CENTER 2600**

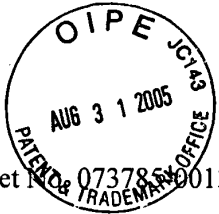

DAC  
IPW

Docket No. 073785.0013

PATENT

**IN THE UNITED STATES PATENT AND TRADEMARK OFFICE**

In re Application of	:	Customer Number: 33401
	:	
C. Earl WOOLFORK	:	Confirmation Number: 3337
	:	
Application No.: 10/648,012	:	Group Art Unit: 2644
	:	
Filed: August 26, 2003	:	Examiner: Graham, Andrew
	:	
For: WIRELESS DIGITAL AUDIO SYSTEM	:	

**PETITION FOR UNINTENTIONALLY DELAYED CLAIM FOR § 120 PRIORITY UNDER 37 C.F.R. § 1.78(a)(3)**

Mail Stop Petition  
Commissioner for Patents  
P.O. Box 1450  
Alexandria, VA 22313-1450

Dear Sir:

Applicant respectfully requests acceptance of the revised priority claim in the above identified application.

U.S. Application No. 10/648,012 (hereinafter '012 application), filed on or about August 26, 2003, was filed as an utility application pursuant to 37 C.F.R. 1.53(b). As evident from the transmittal sheet (Exhibit A) submitted at the time the '012 application was filed, Applicant identified the '012 application as a continuation-in-part for U.S. Application No. 10/027,391 (hereinafter '391 application) filed on December 21, 2001.

However, in the continuation-in-part application dated August 25, 2003, which was the subject of the transmittal sheet, the priority claim provided the incorrect serial no. (Exhibit B) which inadvertently identified the '012 application as a continuation-in-part of serial no. 10/027, 739, rather than a continuation-in-part of the '391 application. Accordingly, the '391 application was not correctly identified in the specification as a prior U.S. application with benefit claimed

09/01/2005 TBESHAHI 00000013 501946 10648012

01 FC:1454 1370.00 DA  
LAS99 1417278-1.073785.0013

10/648,012

under 35 U.S.C. § 120. On or about October 25, 2004, Applicant's prior counsel submitted an amendment to the first line of the specification of the '391 application (Exhibit C, p. 3) so that the revised priority claim clarifies that priority is being claimed to the earlier filed '391 application.

Applicant petitions the Patent Office to accept the amendment to the first line of the specification of the '012 application, to contain reference to the benefit claimed under 35 U.S.C. § 120 to the '391 application.

The entire delay in claiming priority to the '391 application between the date the claim was due under 37 C.F.R. § 1.78(a)(2)(ii) and the date the revised priority claim was filed was unintentional (see the attached declaration of applicant's prior counsel as Exhibit D).

The surcharge set forth by 37 C.F.R. §§ 1.78(a)(3)(ii), and 1.17(t) of \$1,370.00 accompanies this petition. Please charge Deposit Account 501946 the fee of \$1,370.00 if such petition is necessary to revise the priority claim.

To the extent necessary, a petition for an extension of time under 37 C.F.R. 1.136 is hereby made. Please charge any shortage in fees due in connection with the filing of this paper, including extension of time fees, to Deposit Account 501946 and please credit any excess fees to such deposit account.

Respectfully submitted,

McDERMOTT WILL & EMERY LLP



Daphne L. Burton

Registration No. 45,323

2049 Century Park East, Suite 3400  
Los Angeles, California 90067  
Phone: 310.788.4125  
Facsimile: 310.277.4730  
**Date: August 29, 2005**

**Please recognize our Customer No. 33401  
as our correspondence address.**

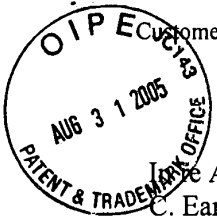

Customer No. 33401

Attorney Docket No. 073785-013

**IN THE UNITED STATES PATENT AND TRADEMARK OFFICE**

Inventor Application of:  
C. Earl WOOLFORK

Group Art Unit: 2644

Examiner: Andrew Graham

Serial No.: 10/648,012

Filed: August 26, 2003

For: WIRELESS DIGITAL AUDIO  
SYSTEM

**CERTIFICATE OF MAILING (37 C.F.R. § 1.8(a))**

I hereby certify that this correspondence is being deposited with the United States Postal Service as First Class Mail under 37 CFR 1.8(a) in an envelope addressed to, Mail Stop: Petition, Commissioner for Patents, P.O. Box 1450, Alexandria, VA 22313-1450 on August 29, 2005.

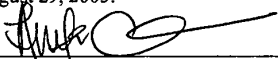
  
Anita Chou

Mail Stop: Petition  
Commissioner for Patents  
P.O. Box 1450  
Alexandria, VA 22313-1450

**TRANSMITTAL**

Sir:

Transmitted herewith is a Petition for Unintentionally Delayed Claim for §120 Priority under 37 CFR §1.78(a)(3) and Exhibits for the above-identified application.

- Please charge my Deposit Account No. 50-1946 the amount of \$1,370.00. A duplicate copy of this sheet is enclosed.
- We authorize the Commissioner to charge Deposit Account No. 50-1946 for payment of any additional fees required by this response or to credit any overpayment to the account.

August 29, 2005  
DATE

  
Daphne L. Burton  
Registration No. 45,323  
Attorney for Applicant

MCDERMOTT, WILL & EMERY, LLP  
2049 Century Park East, 34th Floor  
Los Angeles, CA 90067  
Telephone: (310) 277-4110  
Facsimile: (310) 277-4730

LAS99 1417385-1.073785.0013

10/648, 012

Law Offices of  
**DENNIS W. BEECH**

Landmark Building - Newland Center  
19900 Beach Blvd., Suite C-2  
Huntington Beach, CA 92648  
BUS: (714) 378-0212  
FAX: (714) 378-0262

Meridien Building  
1007 West Avenue M-14, Suite C-10  
Palmdale, California 93551  
BUS: (805) 273-0503  
FAX: (714) 378-0262

**RESPOND TO: HUNTINGTON BEACH**

August 25, 2003

Mail Stop Patent Application  
Commissioner for Patents  
P.O. Box 1450  
Alexandria, VA 22313-1450

**EV203842632US**

Serial No.: 10/027,391  
Applicant: C. Earl Woolfork  
Filing Date: 12/21/2001  
Group Art Unit: 2644  
Examiner: McChesney, Elizabeth A.  
For: WIRELESS DIGITAL AUDIO SYSTEM

Dear Assistant Commissioner for Patents:

This amendment, and fee for CIP application are filed to maintain the parent case which is to be abandoned when filing a new application claiming its benefit.

1. The amendment in this case is a bona fide attempt by applicant to respond and to advance this application to final action and comprises a separately filed:
  - (a)  Continuation Application
  - (b)  Continuation-in-Part Application
  - (c)  Divisional Application (where parent case is to be abandoned).

A copy of this amendment and petition is being filed with the papers constituting the filing of the separately filed application.

2. The amendment being filed in this case is attached.
3. This is not a petition for extension of time to respond to:
  - (d)  the Office Action mailed on \_\_\_\_\_, and Advisory Action dated \_\_\_\_\_.

(e)  Other: The Office Action dated 02/26/2003 did not specify a shortened time period for reply.

4. Please abandon this application conditioned upon the granting of the petition and granting of a filing date to the continuing application so as to make the continuing application co-pending with this application.

5. Applicant is:

a small entity verified statement

is enclosed.

was filed in parent application (a copy attached) and this status is still proper and its benefit under 37 CFR 1.28 (a) is hereby claimed.

other than a small entity.

6. Extension requested under 37 CFR 1.17(c) is for \_\_\_\_\_ months to \_\_\_\_\_ for a fee of \$-----.

7. Enclosed is:

Continuation-in-Part Patent Application including:

11 pages of specifications  
2 pages of drawings  
Small Entity Statement  
Combination Declaration and Power of Attorney  
Nonpublication Request  
Proof of Mailing  
Self Addressed Postcard  
A check in the amount of \$375.00

This amount is based on:

5 claim and 3 independent claim	\$375.00
0 independent claims in excess of three (\$42.00)	0.00
0 claims in excess of twenty (\$9.00)	0.00

TOTAL FILING FEE:

\$375.00

Very truly yours,

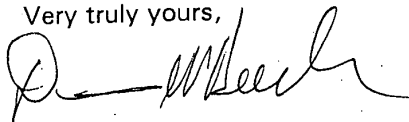

DENNIS W. BEECH  
Reg. No.: 35,443  
DWB/ab  
Enclosures



## FUZZY AUDIO WIRELESS MUSIC SYSTEM

This is a continuation-in-part of application Serial No. 10/027,739  
which patent application is pending.

5

### BACKGROUND OF THE INVENTION

[0001] This invention relates to audio player devices and more particularly to systems that include headphone listening devices. The new audio system uses existing audio player device headphone jacks to connect a battery powered transmitter for wireless transmission of a signal to a battery powered receiving headphone.

[0002] Use of audio headphones with audio player devices such as radio, tape players, CD players, computers, television audio and the like have been in use for many years. These systems usually incorporate an audio source having a headphone jack to which a headphone may be connected by wire and connector.

[0003] There are also known wireless headphones that may receive A.M. and F.M. radio transmissions. However, these systems do not allow use of a simple plug in battery powered transmitter for connection to any audio player device jack, such as, laptop and desktop computers, portable compact disc players, portable MP3 players, portable cassette players and the like, for wireless transmission and reception of audio music for private listening to multiple users occupying the same space. Existing audio systems make use of electrical wire connections between the audio source and the headphones to accomplish private listening to multiple users.

[0004] There is a need for a battery powered simple connection system for existing audio player devices, to allow wireless transmission to a headphone receiver that accomplishes private listening to multiple users occupying the same space.

30

## SUMMARY OF THE INVENTION

5 [0005] The present invention is directed to FAWM (Fuzzy Audio Wireless Music) systems for coded digital transmission of an audio signal from any audio player device with a headphone jack to a receiver headphone using fuzzy logic technology. A battery powered digital transmitter may include a headphone plug in communication with any of the previously mentioned audio sources, 10 laptop and desktop computers, portable compact disc players, portable MP3 players, portable cassette players and the like. The FAWM system converts the audio music signal that may be supplied by the source, into a digital signal. This conversion takes place in the small battery powered transmitter that connects to the headphone jack of the source. The transmitter then adds a 15 unique user code and transmits it to the battery powered receiver headphones where the fuzzy logic detector decodes only the unique user code to allow private listening without interference from other users.

[0006] These and other features, aspects and advantages of the present invention will become better understood with reference to the following 20 drawings, description and claims.

## BRIEF DESCRIPTION OF THE DRAWINGS

[0007] Figure 1 illustrates a schematic diagram representation of the 25 FAWM system;

Figure 2 illustrates a graph of the high and low bit fuzzy logic if-then part fuzzy set according to an embodiment of the invention.

30

## DETAILED DESCRIPTION

**[0008]** The following detailed description is the best currently contemplated modes for carrying out the invention. The description is not to be taken in a limiting sense, but is made merely for the purpose of illustrating the general principles of the invention.

**[0009]** Referring to Figure 1, a FAWM system 10 may include a battery powered transmitter 20 connected to a portable audio player or audio source 80. The battery powered transmitter 20 may be connected to the audio source 80 headphone jack 82 using a headphone plug 22. The battery powered transmitter 20 may have a transmitting antenna 24 that may be omni-directional for transmitting a coded digital modulated signal to a receiving antenna 52 of a battery powered receiver 50 that may be a headphone receiver. The battery powered receiver 50 may have headphone speakers 54 in headphones 55 for listening to the demodulated and decoded digital signal. The FAWM transmitter 20 may digitize the audio signal. This digital signal has a throughput of approximately 1.4 Mbps, which may be determined by the analog to digital A/D converter sampling rate of 44.1kHz multiplied by 16 bit quantization. To reduce the effects of channel noise, the battery powered transmitter 20 may use convolutional encoding, and interleaving. For further noise immunity, spread spectrum modulation may be utilized. The battery powered transmitter 20 may contain a shift register generator (SRG) that may be used to create a unique user code. The unique user code generated is specifically associated with one FAWM user, and it is the only code recognized by the battery powered FAWM headphone receiver 50 of that particular user. The radio frequency (RF) spectrum utilized (as taken from the Industrial, Scientific and Medical (ISM) band), may be approximately 2.4 GHz. And the power radiated by the transmitter adheres to the ISM standard.

**[0010]** Referring to Figure 1, the digital modulated signal from transmitting antenna 24 may be received by receiving antenna 52 and then demodulated,

decoded and deinterleaved in the battery powered receiver 50 headphones. The battery powered receiver 50 may utilize fuzzy logic to optimize the detection of the received user code.

5 [0011] Each receiver 50 user may be able to listen (privately) to high fidelity audio music, using any of the audio devices listed previously, without the use of wires, and without interference from any other receiver 50 user. Because of the fuzzy logic detection technique used in the wireless digital audio system, user separation through code division may be achieved.

10 [0012] The battery powered transmitter 20 sends the audio information to the battery powered receiver 50 in digital packet format. Each packet may consist of, at minimum, a start bit to indicate the beginning of a packet, the unique user code, the digitized audio information and a stop bit to indicate the end of a packet. These packets may flow to create a digital bit stream rate less than or equal to 1 Mb/s.

15 [0013] The user code bits in each packet may be received and detected by a fuzzy logic detector in the headset receiver 50. For each consecutive packet received, the fuzzy logic detector may compute a conditional density with respect to the context and fuzziness of the user code vector, i.e., the received user code bits in each packet. The fuzzy logic detector is the key component to  
20 the FAWM system 10. Because the fuzzy logic detector enables the battery powered FAWM receiver 50 to accurately detect the assigned user code in the presence of noise, which includes other FAWM users. Fuzziness may describe the ambiguity of the high (1)/low (0) bit event in the noisy received packet. Note that the fuzzy detector may measure the degree to which a high/low bit occurs  
25 in the user code vector, which produces a low probability of bit error in the presence of noise. The fuzzy detector may use a set of if-then rules to map the user code bit inputs to validation outputs. These rules may be developed as if-then statements.

30 [0014] The fuzzy logic detector in the battery powered receiver 50 utilizes the if-then fuzzy set to map the received user code bits into two values; a low

(0) and a high (1). Thus, as the user code bits are received, the "if" rules map the signal bit energy to the fuzzy set low value to some degree and to the fuzzy set high value to some degree. See Figure 2. Due to additive noise each user code bit (bit energy  $x$ ) may have some membership to a low and high as represented in Figure 2. Therefore, the if-part fuzzy set may determine if each bit in the user code, for every received packet, has a greater membership to a high bit representation or a low bit representation. The more a user code bit energy,  $x$  fits into the high or low representation, the closer its subsethood, i.e., a measure of the degree to which a set may be a subset of another set, may be to one. Note that Figure 2 shows that -1 equals the maximum low bit energy representation and 1 equals the maximum high bit energy representation to illustrate that this design may utilize Manchester encoding/decoding schemes.

[0015] The received user code input bit in each packet may be:

$x(i)$ , where  $i = 1, 2, \dots, n$  is the set of all bits that make up the user code vector.

$X(c)$ , where  $c = 1, 2, \dots, m$  represents each user assigned a unique user code.

So user  $X(1)$  has bit code  $[x(1) x(2) \dots x(n)]$  and user  $X(m)$  has bit code  $[x(1) x(2) \dots x(n)]$  which is different from user  $X(1)$ .

[0016] Each  $x$  in  $X$  may activate a fuzzy "if" rule. The if-part sets may be conditional densities, so the fuzzy "if" rule activates to the degree  $p[x(i)|X(c)] p[X(c)]$ , which is the probability of the user code bits  $x$  given the user vector  $X$  multiplied by the probability of  $X$ .

[0017] The then-part fuzzy rule set may be indirectly dependent on the input bits  $x$  in  $X$ . The then-part set may be a weighted sum equal to  $p[x(i)] p[y|x(i), i = 1, 2, \dots, n]$ .

[0018] Which is the probability of the user bit vector  $x$  multiplied by the probability of  $y$  given the user bit vector  $x$ . Where  $y$  may be a number representation to define the correct user headset battery powered receiver 50

given the input bit set  $x(i)$ ,  $i = 1, 2, \dots, n$ .

**[0019]** The if-then rule parts that make up the fuzzy logic detector must be followed by a defuzzifying operation. This operation reduces the output fuzzy set to a single number that determines if the correct received user code bits within the transmitted packet have been detected. The defuzzifying operation may be implemented with the modal method, i.e., calculation of the value that has the highest membership in the fuzzy set. With the modal method a strategy of clarity may be applied in the event that some user code energy bit values have equally high membership. The clarity of a fuzzy set may be considered by weighting the conditional densities discussed previously. The weighting determines relative fuzziness of the user code energy bit ( $x$ ) that gives a measure of the uncertainty of the unique user code vector. As a result, the fuzzy logic detector used in the battery powered headset receiver 50 greatly reduces the unique user code bit error probability. The fuzzy logic detector technique, combined with convolutional error detection and correction techniques, may enable the FAWM system 10 to operate in most any environment.

**[0020]** While the invention has been particularly shown and described with respect to the illustrated and preferred embodiments thereof, it will be understood by those skilled in the art that the foregoing and other changes in form and details may be made therein without departing from the spirit and scope of the invention.

25

## CLAIMS

I claim:

1. A fuzzy audio wireless music system for wireless transmission of a signal from an audio source to a battery powered headphone receiver comprising:

a headphone jack from an audio source in communication with a connectable battery powered transmitter;

said connectable battery powered transmitter contains an A/D converter wherein said A/D converter converts an analog music audio signal to a digital signal at a signal rate of approximately 1.4 Mbps;

said A/D converter in communication with a shift register generator, a convolutional encoder and an interleaver;

said interleaver in communication with a spread spectrum modulator;

said spread spectrum modulator in communication with a transmit antenna for wireless transmission of a coded digital signal to a receiving antenna at a radio frequency of approximately 2.4 GHz;

said receiving antenna in communication with a spread spectrum demodulator, a convolutional deinterleaver and a decoder; and

said decoder in communication with a fuzzy logic detector.

2. The fuzzy audio wireless music system as in claim 1 wherein said battery powered headphone receiver having said fuzzy logic detector with a detection method, comprising the steps of:

a) receiving a user code having:

$x(i)$  where  $i = 1, 2, \dots, n$  is the set of all bits that make up the user code vector;

$X(c)$ , where  $c = 1, 2, \dots, m$  represents each user assigned

unique user code;

Wherein user  $X(1)$  has bit code  $[x(1) x(2) \dots X(n)]$  and user  $X(m)$  has bit code  $[x(1) x(2) \dots x(n)]$  which is different from  $X(1)$ ;

b) activating a fuzzy if rule based on each  $x$  in  $X$  wherein the if part sets are conditional densities to activate the if rule to the degree  $p[x(i)|X(c)]$   $p[X(c)]$ ;

c) activating a fuzzy then rule indirectly dependent on each  $x$  in  $X$  wherein the then part sets are a weighted sum equal to  $p[x(i)]p[y|x(i)]$ ,  $i = 1, 2, \dots, n$ ; and

d) performing a defuzzifying operation of modal type.

3. A battery powered headphone receiver having a fuzzy logic detector method, comprising the steps of:

a) receiving a user code having:

$x(i)$  where  $i = 1, 2, \dots, n$  is the set of all bits that make up the user code vector;

$X(c)$ , where  $c = 1, 2, \dots, m$  represents each user assigned unique user code;

wherein user  $X(1)$  has bit code  $[x(1) x(2) \dots X(n)]$  and user  $X(m)$  has bit code  $[x(1) x(2) \dots x(n)]$  which is different from  $X(1)$ ;

b) activating a fuzzy if rule based on each  $x$  in  $X$  wherein the if part sets are conditional densities to activate the if rule to the degree  $p[x(i)|X(c)]$   $p[X(c)]$ ;

c) activating a fuzzy then rule indirectly dependent on each  $x$  in  $X$  wherein the then part sets are a weighted sum equal to  $p[x(i)]p[y|x(i)]$ ,  $i = 1, 2, \dots, n$ ; and

d) performing a defuzzifying operation of modal type.

4. A method for battery powered digital wireless transmission and reception of high fidelity audio music between a battery operated transmitter



and a battery operated receiver comprising the step of:

connecting a headphone plug attached to said battery operated transmitter to a headphone jack of an audio source;

converting an music audio signal to a digital signal using an A/D converter having a sampling rate of approximately 44.1 kHz multiplied by 16 bit quantization to produce a signal rate of approximately 1.4 Mbps;

encoding the digital signal using a convolutional encoding and interleaving method;

creating a spread spectrum signal using a shift register generator to modulate a unique user code;

transmitting said spread spectrum signal at a radio frequency of approximately 2.4 GHz at a power level that adheres to the ISM standard for reception at a distance of up to approximately 10 feet from said battery operated transmitter;

receiving said spread spectrum signal at said battery operated receiver headphones;

demodulating said spread spectrum signal and optimal bit detecting of said unique user code using fuzzy logic technology;

convolutional decoding and deinterleaving to receive said digital signal;

converting said digital signal to said analog music audio signal; and

communication said analog music audio signal to a headphone speaker.

5. The battery powered receiver headphone as in claim 4 wherein said receiver having a fuzzy logic detector method comprising the steps of:

a) receiving a user code having:

$x(i)$  where  $i = 1, 2, \dots, n$  is the set of all bits that make up the user code vector;

$X(c)$ , where  $c = 1, 2, \dots, m$  represents each user assigned unique user code;

Wherein user  $X(1)$  has bit code  $[x(1) x(2) \dots x(n)]$  and user  $X(m)$  has bit code  $[x(1) x(2) \dots x(n)]$  which is different from  $X(i)$ ;

b) activating a fuzzy if rule based on each  $x$  in  $X$  wherein the if part sets are conditional densities to activate the if rule to the degree  $p[x(i)|X(c)]$   $p[X(c)]$ ;

c) activating a fuzzy then rule indirectly dependent on each  $x$  in  $X$  wherein the then part sets are a weighted sum equal to  $p[x(i)]p[y|x(i)]$ ,  $i = 1, 2, \dots, n$ ; and

d) performing a defuzzifying operation of modal type.

## FUZZY AUDIO WIRELESS MUSIC SYSTEM

### ABSTRACT OF THE DISCLOSURE

5 [0021] The fuzzy audio wireless music system may utilize a battery  
powered transmitter to transmit a coded digital signal from an audio player  
device or source to a battery powered headphone receiver without the use of  
wires. A battery powered digital transmitter may include a headphone plug in  
communication with any audio source, such as, laptop and desktop computers,  
10 portable compact disc players, portable MP3 players, portable cassette players,  
etc. The battery powered transmitter adds a unique user code and transmits it  
to the battery powered receiver headphones where a fuzzy logic detector  
decodes only the unique user code to allow private listening without  
interference from other users.

15

IN THE UNITED STATES PATENT AND TRADEMARK OFFICE

In regards to application of:

Serial Number: 10/027,391  
Applicant: C. EARL WOOLFORK  
Filing Date: 12-21-01  
Group Art Unit: 2644  
Examiner: MC CHESNEY, ELIZABETH A.  
For: WIRELESS DIGITAL AUDIO SYSTEM

Box: Non-Fee Amendment  
Assistant Commissioner for Patents  
Washington, DC 20231

CERTIFICATE OF MAILING UNDER 37 CFR § 1.10

Express Mail label number: EL 870683609 US  
Date of Deposit: November 26, 2002

I hereby certify that the following attached correspondence comprising:

8 page specifications  
1 page drawing  
Version with Markings to Show Changes Made

is being deposited with the United States Postal Service as Express Mail to Addressee" service under 37 CFR § 1.10 on the date indicated below and is addressed to:

BOX: Non-Fee Amendment  
Assistant Commissioner for Patents  
Washington, DC 20231

Date: 11-26-02

  
Annerose Beech

Law Offices of  
**DENNIS W. BEECH**

Landmark Building - Newland Center  
19900 Beach Blvd., Suite C-2  
Huntington Beach, CA 92648  
BUS: (714) 378-0212  
FAX: (714) 378-0262

**RESPOND TO: HUNTINGTON BEACH**

Palmdale/Lancaster: (661) 273-0503  
Temecula/Murrieta: (909) 986-4624  
Brea/Ontario: (909) 986-4624  
Bakersfield: (661) 821-6911  
Fax: (714) 378-0262

EXPRESS MAIL

EV482347413US

October 25, 2004

Mail Stop NON-FEE AMENDMENT  
Commissioner for Patents  
P.O. Box 1450  
Alexandria, VA 22313-1450

Serial Number: 10/648,012  
Applicant: C. Earl Woolfork  
Filing Date: 08/26/2003  
Title: WIRELESS DIGITAL AUDIO SYSTEM  
TC/AU: 2644  
Examiner: Graham, Andrew R.

**PRELIMINARY AMENDMENT**

TO THE COMMISSIONER FOR PATENTS:

The following preliminary amendment is submitted for US Patent Application No. 10/648,012 filed on 08-26-2003.

Applicant respectfully submits the following amendments to the application. Applicant believes this amendment is supported by the original disclosure and that no new matter is added by this amendment.

## **AMENDMENTS**

**Amendments to the Specification** begin on page 3 of this paper.

**Amendments to the Claims** are reflected in the listing of claims that begins on page 9 of this paper.

**Remarks/Arguments** begin on page 13 of this paper.

## **AMENDMENTS TO THE SPECIFICATION**

In the Abstract of the Disclosure: (Place a replacement or new abstract on a separate sheet)

[0021] The fuzzy audio wireless music system utilizes a battery powered **BLUETOOTH** compliant transmitter to transmit a coded digital **BLUETOOTH communication** signal from an existing ~~non-BLUETOOTH analog headphone jack of a music~~ audio player device or source to a battery powered **BLUETOOTH compliant** headphone receiver without the use of wires. A battery powered digital **BLUETOOTH compliant** transmitter may include a headphone plug in communication with a ~~standard analog headphone jack on a~~ audio source, such as, laptop and desktop computers, portable compact disc players, portable MP3 players, portable cassette players,....etc. The battery powered **BLUETOOTH compliant** transmitter adds a unique user code ~~as defined in the BLUETOOTH standard~~ and transmits it to the battery powered **BLUETOOTH compliant** receiver headphones where a fuzzy logic detector ~~detection system may be used to enhance decoding performance.~~ ~~decodes only the unique user code to~~ **The BLUETOOTH communication FAWM system will** allow private listening without interference from other users, ~~and without the inconvenience of wires.~~

In the Specifications:

Please replace the paragraphs and the beginning of the specification with the following rewritten paragraphs and beginning:

### **FUZZY AUDIO WIRELESS MUSIC SYSTEM**

This is a continuation-in-part of application Serial No. ~~40/027,739~~ 10/027,391  
which patent application is pending.

### **BACKGROUND OF THE INVENTION**

[0001] This invention relates to music audio player devices and more particularly to systems that include headphone listening devices. The new audio music system uses ~~an existing device~~ non-BLUETOOTH headphone jack (~~i.e., this is the standard analog headphone jack that connects to wired headphones~~) of a music audio player (~~i.e., portable CD player, portable cassette player,~~

~~portable A.M./F.M. radio, laptop/desktop computer, portable MP3 player, and the like~~) to connect a battery powered BLUETOOTH compliant transmitter for digital wireless transmission of a BLUETOOTH communication signal to a set of battery powered BLUETOOTH compliant receiver headphones. BLUETOOTH is a worldwide wireless standard. Detailed Information regarding the standard is available on the web site www.bluetooth.com.

[0002] Use of music audio headphones with music audio player devices such as ~~radio, tape players, CD players, computers, television audio portable CD players, portable cassette players, portable A.M./F.M. radios, laptop/desktop computer, portable MP3 players and the like~~, have been in use for many years. These systems incorporate an audio source having a analog non-BLUETOOTH headphone jack to which headphones may be connected by wire ~~and connector~~ .

[0003] There are also known non-portable wireless headphones that may receive A.M. and F.M. radio infrared (IR) transmissions. However, ~~these systems operate with a narrow beam width that requires a point-and-shoot style for reception. these systems~~ They do not allow use of a simple plug in (i.e., plug in to the existing analog audio headphone jack) battery powered BLUETOOTH compliant transmitter for connection to any music audio player device jack, ~~such as, laptop and desktop computers, portable compact disc players, portable MP3 players, portable cassette players and the like, such as the above mentioned music audio player devices~~ for coded digital wireless transmission and reception by BLUETOOTH compliant headphones of audio music for private listening to multiple users occupying the same space without the use of wires. Existing audio systems make use of electrical wire connections between the audio source and the headphones to accomplish private listening to multiple users.

[0004] There is a need for a battery powered simple connection system for existing music audio player devices (i.e., the previously mentioned music devices), to allow coded digital wireless transmission (using a battery powered BLUETOOTH compliant transmitter) to a headphone receiver (using battery powered BLUETOOTH compliant receiver headphones) that accomplishes private listening to multiple users occupying the same space without the use of wires.

#### SUMMARY OF THE INVENTION

[0005] The present invention is directed to FAWM (Fuzzy Audio Wireless Music) systems for coded digital transmission, per the BLUETOOTH standard, of an analog audio signal from any music audio player device with a non-BLUETOOTH analog headphone jack to a receiver headphone, which adheres to the BLUETOOTH standard. using Fuzzy logic technology may be



~~utilized by the FAWM system to enhance bit detection. A battery powered digital BLUETOOTH compliant transmitter may include a headphone plug in communication with any of the previously mentioned music audio sources laptop and desktop computers, portable compact disc players, portable MP3 players, portable cassette players and the like. For reception, a battery powered BLUETOOTH compliant headphone receiver may apply fuzzy logic to enhance bit detection. Fuzzy logic detection may be used to enhance bit detection during decoding of the BLUETOOTH communication signal. The FAWM system converts the audio music signal that may be supplied by the source, into a digital signal. This conversion takes place in the small battery powered transmitter that connects to the headphone jack of the source. The transmitter then adds a unique user code and transmits it to the battery powered receiver headphones where the fuzzy logic detector decodes only the unique user code to allow will provide private listening without interference from other users and without the use of wires.~~

[0006] These and other features, aspects and advantages of the present invention will become better understood with reference to the following drawings, description and claims.

#### BRIEF DESCRIPTION OF THE DRAWINGS

[0007] Figure 1 illustrates a schematic diagram representation of the FAWM system;

Figure 2 illustrates a graph of the high and low bit fuzzy logic if-then part fuzzy set according to an embodiment of the invention.

#### DETAILED DESCRIPTION

[0008] The following detailed description is the best currently contemplated modes for carrying out the invention. The description is not to be taken in a limiting sense, but is made merely for the purpose of illustrating the general principles of the invention.

[0009] Referring to Figure 1, a FAWM system 10 may include a battery powered BLUETOOTH compliant transmitter 20 connected to a portable music audio player (or music audio source) 80. The battery powered BLUETOOTH compliant transmitter 20 that utilizes a CODEC and BLUETOOTH front end may be connected to the music audio source 80 analog non-BLUETOOTH headphone jack 82 using a headphone plug 22. The battery powered BLUETOOTH compliant transmitter 20 may have a transmitting antenna 24 that may be omni-directional for transmitting a

~~coded digital spread spectrum~~ modulated signal, ~~which adheres to the BLUETOOTH standard~~, to a receiving antenna 52 of a battery powered BLUETOOTH compliant headphone receiver 50. The battery powered BLUETOOTH compliant receiver 50 may have headphone speakers 54 in headphones 55 for listening to the ~~spread spectrum~~ demodulated and decoded ~~digital~~ BLUETOOTH communication signal. ~~During decoding, fuzzy logic detection may be used to increase receiver decoding performance.~~ The FAWM BLUETOOTH compliant transmitter 20 may digitize the audio signal ~~per the BLUETOOTH standard using a CODEC and BLUETOOTH front end.~~ This BLUETOOTH compliant digital signal has a throughput of approximately 1.4 Mbps ~~that may be as low as approximately 1.0 Mbps, which may be determined by the analog-to-digital A/D converter sampling rate of 44.1kHz multiplied by 16 bit quantization.~~ To reduce the effects of channel noise, the battery powered BLUETOOTH compliant transmitter 20 may use convolutional channel encoding and interleaving. For further noise immunity, spread spectrum modulation, ~~as defined in the BLUETOOTH standard may be~~ is utilized. The battery powered BLUETOOTH compliant transmitter 20 may contain a BLUETOOTH compliant shift register generator, ~~or the like~~, that may be used to create a unique user code. The unique user code generated is specifically associated with one FAWM user, and it is the only code recognized by the battery powered FAWM BLUETOOTH compliant headphone receiver 50 ~~of that operated by a~~ particular user. The radio frequency (RF) spectrum utilized (as taken from the Industrial, Scientific and Medical (ISM) band), may be approximately 2.4 GHz ~~as defined in the BLUETOOTH standard~~. And the power radiated by the BLUETOOTH compliant transmitter adheres to the BLUETOOTH standard.

[0010] Referring to Figure 1, the ~~digital spread spectrum~~ modulated BLUETOOTH compliant signal from transmit antenna 24 may be received by receiving antenna 52 and then ~~spread spectrum~~ demodulated ~~per the BLUETOOTH standard, decoded and deinterleaved~~ in the battery powered BLUETOOTH compliant receiver 50 headphones. The battery powered BLUETOOTH compliant receiver 50 may utilize fuzzy logic to optimize the ~~bit~~ detection of the received ~~packet~~ code.

[0011] Each BLUETOOTH compliant receiver headphone 50 user may be able to listen (privately) to high fidelity audio music, using any of the audio devices listed previously, without the use of wires, and without interference from any other BLUETOOTH compliant receiver headphone 50 user. . ~~Because of the fuzzy logic detection technique used in the wireless digital audio system, user separation through code division may be achieved. The fuzzy logic detection technique that may be used in the FAWM could provide greater user separation through optimizing code division in the BLUETOOTH compliant headphone receiver.~~

[0012] The battery powered BLUETOOTH compliant transmitter 20 sends the audio music

information to the battery powered BLUETOOTH compliant receiver 50 in digital packet format as defined in the BLUETOOTH standard. These packets may flow to create a digital bit stream rate of less than or equal to 1.0 Mbps as defined in the BLUETOOTH standard.

[0013] The user code bits in each packet may also be received and detected by a fuzzy logic detection system (as an option) in the headset receiver 50 to provide additional decoding performance. For each consecutive packet received, the fuzzy logic detection system may compute a conditional density with respect to the context and fuzziness of the user packet code vector, i.e., the received user code bits in each packet. The fuzzy logic detector detection system is the key component ~~to the~~ may enable the battery powered FAWM BLUETOOTH compliant system 10. ~~Because the fuzzy logic detector enables the battery powered FAWM receiver 50 to enhance the bit detection accuracy of the packet code in the presence of noise, which may include other FAWM users. Fuzziness may describe the ambiguity of the high bit (1)/low bit (0 or -1) bit event in the received code within the packet. Note that the~~ The fuzzy logic detection system detector may measure the degree to which a high/low bit occurs in the user packet code vector, which produces a low probability of bit error in the presence of noise. The fuzzy logic detection system may use a set of if-then rules to map the code bit inputs to validation outputs. These rules may be developed as if-then statements.

[0014] The fuzzy logic detector detection system in the battery powered BLUETOOTH compliant headphone receiver 50 utilizes the if-then fuzzy set to map the received user code bits into two values; a low (0 or -1) and a high (1). Thus, as the user code bits are received, the "if" rules map the signal bit energy to the fuzzy set low value to some degree and to the fuzzy set high value to some degree. See Figure 2. ~~Due to additive noise each user code bit (bit energy x) may have some membership to a low and high as represented in Figure 2. Therefore, the if-part fuzzy set may determine if each bit in the user code, for every received packet, has a greater membership to a high bit representation or a low bit representation. The more a user code bit energy, x fits into the high or low representation, the closer its subsethood, i.e., a measure of the degree to which a set may be a subset of another set, may be to one. Note that Figure 2 shows that -1 equals the maximum low bit energy representation and 1 equals the maximum high bit energy representation to illustrate that this design may utilize Manchester encoding/decoding schemes. Due to additive noise, the code bit energy may have some membership to low and high as represented in Figure 2. The if-part fuzzy set may determine if each bit in the code, for every received packet, has a greater membership to a high bit representation or a low bit representation. The more a user code bit energy fits into the high or low representation, the closer its subsethood,~~

i.e., a measure of the degree to which a set may be a subset of another set, may be to one.

[0015] The received user code input bit in each packet may be:

$x(i)$ , where  $i = 1, 2, \dots, n$  is the set of all bits that make up the user code vector.

$X(c)$ , where  $c = 1, 2, \dots, m$  represents each user assigned a unique user code.

So user  $X(1)$  has bit code  $[x(1) x(2) \dots x(n)]$  and user  $X(m)$  has bit code  $[x(1) x(2) \dots x(n)]$  which is different from user  $X(1)$ .

[0016] Each  $x$  in  $X$  may activate a fuzzy "if" rule. The if-part sets may be conditional densities, so the fuzzy "if" rule activates to the degree  $p[x(i)|X(c)] p[X(c)]$ , which is the probability of the user code bits  $x$  given the user vector  $X$  multiplied by the probability of  $X$ .

[0017] The then-part fuzzy rule set may be indirectly dependent on the input bits  $x$  in  $X$ . The then-part set may be a weighted sum equal to  $p[x(i)] p[y|x(i)]$ ,  $i = 1, 2, \dots, n$ .

[0018] Which is the probability of the user bit vector  $x$  multiplied by the probability of  $y$  given the user bit vector  $x$ . Where  $y$  may be a number representation to define the correct user headset battery powered receiver 50 given the input bit set  $x(i)$ ,  $i = 1, 2, \dots, n$ .

[0019] The if-then rule parts that make up the fuzzy logic detector detection system must be followed by a defuzzifying operation. This operation reduces the output aforementioned fuzzy set to a bit energy representation (i.e., -1 or 1) single number that determines if the correct that is received user code bits within by the transmitted BLUETOOTH standard packet. have been detected. The defuzzifying operation may be implemented with the modal method, i.e., calculation of the value that has the highest membership in the fuzzy set. With the modal method a strategy of clarity may be applied in the event that some user code energy bit values have equally high membership. The clarity of a fuzzy set may be considered by weighting the conditional densities discussed previously. The weighting determines relative fuzziness of the user code energy bit ( $x$ ) that gives a measure of the uncertainty of the unique user code vector. As a result, the fuzzy logic detector used in the battery powered headset receiver 50 greatly reduces the unique user code bit error probability.

The fuzzy logic detection system may be used in the battery powered BLUETOOTH compliant headset receiver 50 to enhance overall FAWM system 10 decoding performance. The fuzzy logic detector technique, combined with convolutional error detection and correction techniques, may enable the FAWM system 10 to operate in most any environment.

[0020] While the invention has been particularly shown and described with respect to the illustrated and preferred embodiments thereof, it will be understood by those skilled in the art that the foregoing and other changes in form and details may be made therein without departing from the spirit and scope of the invention.

## **AMENDMENTS TO THE CLAIMS**

This listing of claims will replace all prior versions, and listings, of claims in the application:

### **Listing of Claims:**

1. (currently amended): A fuzzy audio wireless music system for ~~wireless transmission of a signal from~~ BLUETOOTH communication of an audio music signal from the non-BLUETOOTH analog headphone jack connected to a battery powered BLUETOOTH compliant transmitter and received by a battery powered BLUETOOTH compliant source to a battery-powered headphone receiver comprising:

a NON-BLUETOOTH compliant analog headphone jack from an audio music source in communication with a ~~connectable~~ said battery powered BLUETOOTH compliant transmitter;  
said ~~connectable~~ battery powered BLUETOOTH compliant transmitter converts an analog audio music signal from said existing non-BLUETOOTH analog headphone jack to a BLUETOOTH compliant contains ~~an A/D converter wherein said A/D converter converts an analog music audio signal to a digital signal using a CODEC and a BLUETOOTH front end~~ at a signal rate of approximately 1.4 Mbps as defined in the BLUETOOTH standard;

said ~~A/D converter~~ CODEC in communication with a shift register generator ~~that is BLUETOOTH compliant to create a unique user code~~ and a convolutional encoder ~~and an interleaver~~ ;

said ~~interleaver~~ shift register generator in communication with a spread spectrum modulator ~~that is BLUETOOTH compliant;~~

said BLUETOOTH compliant spread spectrum modulator in communication with a transmit antenna for ~~wireless~~ BLUETOOTH compliant transmission of a coded ~~digital signal~~ BLUETOOTH compliant packet to a receiving antenna at a radio frequency of approximately 2.4 GHz as defined in the BLUETOOTH standard;

said receiving antenna in communication with a spread spectrum demodulator ~~that is BLUETOOTH compliant~~ and a convolutional deinterleaver ~~and a decoder;~~ and

said ~~decoder~~ BLUETOOTH compliant spread spectrum demodulator in communication with a fuzzy logic detector detection system for additional decoding performance.

2. (currently amended): The fuzzy audio wireless music system as in claim 1 wherein said battery powered BLUETOOTH compliant headphone receiver having said fuzzy logic detector detection system with a detection method, comprising the steps of:

- a) receiving a user BLUETOOTH compliant packet code bits having:  
 $x(i)$  where  $i = 1, 2, \dots, n$  is the set of all bits that make up the packet user code vector;  
 ~~$X(c)$ , where  $c = 1, 2, \dots, m$  represents each user assigned unique user code; wherein user  $X(1)$  has bit code  $[x(1) x(2) \dots X(n)]$  and user  $X(m)$  has bit code  $[x(1) x(2) \dots x(n)]$  which is different form  $X(1)$ ;~~
- b) activating a fuzzy logic if rule for each bit energy in the packet code based on each  $x$  in  $X$  wherein the if part sets are conditional densities to activate the if rule to the degree  $p[x(i)|X(c)] p[X(c)]$ ;
- c) activating a fuzzy then rule indirectly dependent on each  $x$  in  $X$  wherein the then part sets are a weighted sum equal to  $p[x(i)]p[y|x(i)]$ ,  $i = 1, 2, \dots, n$  received bit energy; and
- d) performing a defuzzifying fuzzy logic operation to relate the bit energy to one of a digital one(1) and digital zero(0) bit representation. of modal type.

3. (currently amended): A battery powered BLUETOOTH compliant headphone receiver possibly having a an additive fuzzy logic detector detection method, comprising the steps of:

- a) receiving a user BLUETOOTH compliant packet code bits having:  
 $x(i)$  where  $i = 1, 2, \dots, n$  is the set of all bits that make up the packet user code vector;  
 ~~$X(c)$ , where  $c = 1, 2, \dots, m$  represents each user assigned unique user code; wherein user  $X(1)$  has bit code  $[x(1) x(2) \dots X(n)]$  and user  $X(m)$  has bit code  $[x(1) x(2) \dots x(n)]$  which is different form  $X(1)$ ;~~
- b) activating a fuzzy logic if rule for each bit energy in the packet code  $x$  in  $X$  wherein the if part sets are conditional densities to activate the if rule to the degree  $p[x(i)|X(c)] p[X(c)]$ ;
- c) activating a fuzzy then rule indirectly dependent on each  $x$  in  $X$  wherein the

then part sets are a weighted sum equal to  $p[x(i)]p[y|x(i)]$ ,  $i = 1, 2, \dots, n$  received bit energy; and

d) performing a defuzzifying fuzzy logic operation to relate the bit energy to one of a digital one(1) and digital zero(0) bit representation. operation of modal type:

4. (currently amended): A method for battery powered digital wireless BLUETOOTH communication transmission and reception of high fidelity audio music between a battery operated BLUETOOTH compliant transmitter and a battery operated BLUETOOTH compliant receiver headphone comprising the step of:

connecting the plug attached to said battery operated BLUETOOTH compliant transmitter to a the existing non-BLUETOOTH compliant analog headphone jack of an audio music source;

converting an a music audio signal to a digital BLUETOOTH communication signal using an A/D converter having a sampling rate of approximately 44.1 kHz multiplied by 16 bit quantization to produce a signal rate of approximately 1.4 Mbps a CODEC and a BLUETOOTH front end;

encoding the digital BLUETOOTH communication signal using a convolutional BLUETOOTH standard convolutional encoding and interleaving method;

creating a BLUETOOTH standard spread spectrum signal using a shift register generator to modulate a unique user code that adheres to the BLUETOOTH standard;

transmitting said BLUETOOTH standard spread spectrum signal at a radio frequency of approximately 2.4 GHz at a power level that adheres to the ISM BLUETOOTH standard for reception at a distance of up to 10 less than approximately 30 feet from said battery operated BLUETOOTH compliant transmitter;

receiving said BLUETOOTH compliant spread spectrum signal at said battery operated BLUETOOTH compliant receiver headphones;

demodulating said BLUETOOTH compliant spread spectrum signal; and optimal bit detecting of said unique user code using fuzzy logic technology;

convolutional decoding and deinterleaving to receive said digital signal; decoding of said BLUETOOTH communication signal as defined in the BLUETOOTH standard, with an option to apply fuzzy logic detection system to enhance bit detection performance;

converting said digital BLUETOOTH communication signal back to said analog music audio signal; and

communication said analog music audio signal to a headphone speaker within the

BLUETOOTH compliant headphone receiver.

5. (currently amended): The ~~battery powered receiver headphone method~~ as in claim 4 wherein said ~~battery operated BLUETOOTH compliant receiver~~ having a fuzzy logic detector method comprising the steps of:

a) receiving a ~~user BLUETOOTH compliant packet code bits~~ having:

~~$x(i)$  where  $i = 1, 2, \dots, n$  is the set of all bits that make up the packet user code vector;~~

~~$X(c)$ , where  $c = 1, 2, \dots, m$  represents each user assigned unique user code; wherein user  $X(1)$  has bit code  $[x(1) x(2) \dots X(n)]$  and user  $X(m)$  has bit code  $[x(1) x(2) \dots x(n)]$  which is different from  $X(1)$ ;~~

b) activating a fuzzy logic if rule for each bit energy in the packet code based on each  $x$  in  $X$  wherein the if part sets are conditional densities to activate the if rule to the degree  $p[x(i)|X(c)] p[X(c)]$ ;

c) activating a fuzzy then rule indirectly dependent on each  $x$  in  $X$  wherein the then part sets are a weighted sum equal to  $p[x(i)]p[y|x(i)]$ ,  $i = 1, 2, \dots, n$  received bit energy; and

d) performing a defuzzifying fuzzy logic operation to relate the bit energy to one of a digital one(1) and digital zero(0) bit representation. operation of modal type.



**REMARKS/ARGUMENTS**

The applicant has provided the following analysis concerning non-introduction of new matter for this preliminary amendment.

"A Special Interest Group (SIG) was formed to create an industry standard for short range low power radio frequency (RF) connectivity to make free use of intellectual property in a specification. The specification is called Bluetooth. The SIG determined a short range low power RF protocol for personal wireless connectivity technologies that allow personal devices to communicate. The Bluetooth wireless technology serves as a replacement of the interconnecting cables between personal electronic devices. Because the FAWM design replaces the interconnecting cable between a portable audio music device and a pair of headphones, it was necessary to follow the Bluetooth specification to adhere to the RF, low power wireless protocol.

In the initial patent application and the CIP the Bluetooth protocol was described, but the name (Bluetooth) was not called out. The key Bluetooth specifications are as follows: The (1) carrier frequency of approximately 2.4 GHz is in the ISM (Industrial, Scientific, & Medical) band, and the (2) data rate is approximately 1 Mbps. The (3) transmit power is not greater than 100 mW (milliwatts), and has a (4) operating range up to 30 ft (or 10 m). To correct errors that may occur during packet transmission, (5) convolutional encoding is used. Finally, (6) spread spectrum technology is used for maximum immunity to interference.

Each of the Bluetooth specifications listed has been included in the initial patent application and the CIP".

No additional fee for claims is seen to be required.

If you have any questions do not hesitate to contact me.

Very truly yours,

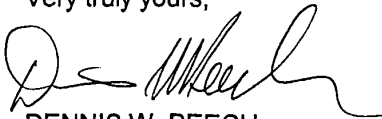

DENNIS W. BEECH  
Reg. No.: 35,443

DWB/ab

**IN THE UNITED STATES PATENT AND TRADEMARK OFFICE**

In regards to application of:

Serial Number: 10/648,012  
Applicant: C. Earl Woolfork  
Filing Date: 08/26/2003  
Title: WIRELESS DIGITAL AUDIO SYSTEM  
TC/AU: 2644  
Examiner: Graham, Andrew R.

Mail Stop Non-Fee Amendment  
Commissioner for Patents  
P.O. Box 1450  
Alexandria, VA 22313-1450

-----  
**EXPRESS MAIL CERTIFICATE MAILING UNDER 37 CFR § 1.10**

"Express Mail" label number: EV 482347413 US

Date of Deposit: October 25, 2004

I hereby certify that the following attached correspondence comprising:

13 Pages of response

is being deposited with the United States Postal Service "Express Mail Post Office to Addressee" service under 37 CFR § 1.10 on the date indicated above and is addressed to:

Mail Stop Non-Fee Amendment  
Commissioner for Patents  
P.O. Box 1450  
Alexandria, VA 22313-1450

Date: 10-25-04

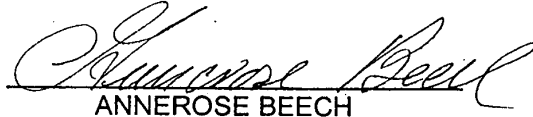
  
ANNEROSE BEECH

**DECLARATION FOR PATENT APPLICATION**

My name is Dennis W. Beech. I am a registered patent attorney who represented C. Earl Woolfork in the filing of a continuation-in-part application serial no. 10/648,012 ("the '012 application"). The '012 application was submitted to the United States Patent and Trademark Office on or about August 25, 2003. I represented C. Earl Woolfork in relation to the '012 application from the date of submission of the '012 application until on or about July 25, 2005.

On the date of submission of the '012 application, a typographical error was made with respect to the application serial number in the first line of the specification. The first line of the specification provided that the '012 application claimed the benefit of priority of U.S. patent application serial no. 10/027,739. The '012 application was intended to include a priority claim to U.S. patent application serial no. 10/027,391. A preliminary amendment was submitted to this effect on or about October 25, 2004.

The entire delay between the date the claim was due and the date the claim was filed was unintentional.

I declare that all statements made herein of my own knowledge are true and that all statements made on information and belief are believed to be true; and further that these statements were made with the knowledge that willful false statements and the like so made are punishable by fine or imprisonment, or both, under Section 1001 of Title 18 of the United States Code and that such willful false statements may jeopardize the validity of the application or any patent issued thereon.

Full name of Declarant <i>Dennis W. Beech</i>	Declarant's signature <i>D. W. Beech</i>	Date <i>8/29/2005</i>
Residence and Post Office Address <i>P.O. Box 519, Murrieta, CA 92564</i>		Citizenship <i>US</i>

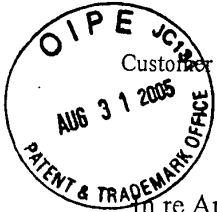

Customer No. 33401

Attorney Docket No. 073785-013

DAC  
JAW

IN THE UNITED STATES PATENT AND TRADEMARK OFFICE

In re Application of:  
C. Earl WOOLFORK  
  
Serial No.: 10/648,012  
  
Filed: August 26, 2003  
  
For: WIRELESS DIGITAL AUDIO  
SYSTEM

Group Art Unit: 2644  
  
Examiner: Andrew Graham

CERTIFICATE OF MAILING (37 C.F.R. § 1.8(a))

I hereby certify that this correspondence is being deposited with the United States Postal Service as First Class Mail under 37 CFR 1.8(a) in an envelope addressed to, Mail Stop: Petition, Commissioner for Patents, P.O. Box 1450, Alexandria, VA 22313-1450 on August 29, 2005.

  
Anita Chou

Mail Stop: Petition  
Commissioner for Patents  
P.O. Box 1450  
Alexandria, VA 22313-1450

**TRANSMITTAL**

Sir:

Transmitted herewith is a Petition for Unintentionally Delayed Claim for §120 Priority under 37 CFR §1.78(a)(3) and Exhibits for the above-identified application.

- Please charge my Deposit Account No. 50-1946 the amount of \$1,370.00. A duplicate copy of this sheet is enclosed.
- We authorize the Commissioner to charge Deposit Account No. 50-1946 for payment of any additional fees required by this response or to credit any overpayment to the account.

August 29, 2005  
DATE

  
Daphne L. Burton  
Registration No. 45,323  
Attorney for Applicant

MCDERMOTT, WILL & EMERY, LLP  
2049 Century Park East, 34th Floor  
Los Angeles, CA 90067  
Telephone: (310) 277-4110  
Facsimile: (310) 277-4730

LAS99 1417385-1.073785.0013

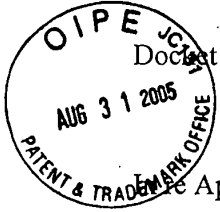

Docket No. 073785-0013

PATENT

IN THE UNITED STATES PATENT AND TRADEMARK OFFICE

Application of	:	Customer Number: 33401
C. Earl WOOLFORK	:	Confirmation Number: 3337
Application No.: 10/648,012	:	Group Art Unit: 2644
Filed: August 26, 2003	:	Examiner: Graham, Andrew
For: WIRELESS DIGITAL AUDIO SYSTEM	:	

PETITION FOR UNINTENTIONALLY DELAYED CLAIM FOR § 120 PRIORITY UNDER 37 C.F.R. § 1.78(a)(3)

Mail Stop Petition  
Commissioner for Patents  
P.O. Box 1450  
Alexandria, VA 22313-1450

Dear Sir:

Applicant respectfully requests acceptance of the revised priority claim in the above identified application.

U.S. Application No. 10/648,012 (hereinafter '012 application), filed on or about August 26, 2003, was filed as an utility application pursuant to 37 C.F.R. 1.53(b). As evident from the transmittal sheet (Exhibit A) submitted at the time the '012 application was filed, Applicant identified the '012 application as a continuation-in-part for U.S. Application No. 10/027,391 (hereinafter '391 application) filed on December 21, 2001.

However, in the continuation-in-part application dated August 25, 2003, which was the subject of the transmittal sheet, the priority claim provided the incorrect serial no. (Exhibit B) which inadvertently identified the '012 application as a continuation-in-part of serial no. 10/027, 739, rather than a continuation-in-part of the '391 application. Accordingly, the '391 application was not correctly identified in the specification as a prior U.S. application with benefit claimed

LAS99 1417278-1.073785.0013

09/01/2005 MBERHE 00000098 501946 10648012  
01 FC:1454 1370.00 DA

10/648,012

under 35 U.S.C. § 120. On or about October 25, 2004, Applicant's prior counsel submitted an amendment to the first line of the specification of the '391 application (Exhibit C, p. 3) so that the revised priority claim clarifies that priority is being claimed to the earlier filed '391 application.

Applicant petitions the Patent Office to accept the amendment to the first line of the specification of the '012 application, to contain reference to the benefit claimed under 35 U.S.C. § 120 to the '391 application.

The entire delay in claiming priority to the '391 application between the date the claim was due under 37 C.F.R. § 1.78(a)(2)(ii) and the date the revised priority claim was filed was unintentional (see the attached declaration of applicant's prior counsel as Exhibit D).

The surcharge set forth by 37 C.F.R. §§ 1.78(a)(3)(ii), and 1.17(t) of \$1,370.00 accompanies this petition. Please charge Deposit Account 501946 the fee of \$1,370.00 if such petition is necessary to revise the priority claim.

To the extent necessary, a petition for an extension of time under 37 C.F.R. 1.136 is hereby made. Please charge any shortage in fees due in connection with the filing of this paper, including extension of time fees, to Deposit Account 501946 and please credit any excess fees to such deposit account.

Respectfully submitted,

McDERMOTT WILL & EMERY LLP



Daphne L. Burton

Registration No. 45,323

2049 Century Park East, Suite 3400  
Los Angeles, California 90067  
Phone: 310.788.4125  
Facsimile: 310.277.4730  
**Date: August 29, 2005**

**Please recognize our Customer No. 33401  
as our correspondence address.**

10/648, 012

Law Offices of  
**DENNIS W. BEECH**

Landmark Building - Newland Center  
19900 Beach Blvd., Suite C-2  
Huntington Beach, CA 92648  
BUS: (714) 378-0212  
FAX: (714) 378-0262

Meridien Building  
1007 West Avenue M-14, Suite C-10  
Palmdale, California 93551  
BUS: (805) 273-0503  
FAX: (714) 378-0262

**RESPOND TO: HUNTINGTON BEACH**

August 25, 2003

Mail Stop Patent Application  
Commissioner for Patents  
P.O. Box 1450  
Alexandria, VA 22313-1450

**EV203842632US**

Serial No.: 10/027,391  
Applicant: C. Earl Woolfork  
Filing Date: 12/21/2001  
Group Art Unit: 2644  
Examiner: McChesney, Elizabeth A.  
For: WIRELESS DIGITAL AUDIO SYSTEM

Dear Assistant Commissioner for Patents:

This amendment, and fee for CIP application are filed to maintain the parent case which is to be abandoned when filing a new application claiming its benefit.

1. The amendment in this case is a bona fide attempt by applicant to respond and to advance this application to final action and comprises a separately filed:
  - (a)  Continuation Application
  - (b)  Continuation-in-Part Application
  - (c)  Divisional Application (where parent case is to be abandoned).

A copy of this amendment and petition is being filed with the papers constituting the filing of the separately filed application.

2. The amendment being filed in this case is attached.
3. This is not a petition for extension of time to respond to:
  - (d)  the Office Action mailed on \_\_\_\_\_, and Advisory Action dated \_\_\_\_\_.

(e)  Other: The Office Action dated 02/26/2003 did not specify a shortened time period for reply.

4. Please abandon this application conditioned upon the granting of the petition and granting of a filing date to the continuing application so as to make the continuing application co-pending with this application.

5. Applicant is:

a small entity verified statement

is enclosed.

was filed in parent application (a copy attached) and this status is still proper and its benefit under 37 CFR 1.28 (a) is hereby claimed.

other than a small entity.

6. Extension requested under 37 CFR 1.17(c) is for \_\_\_\_\_ months to \_\_\_\_\_ for a fee of \$-----.

7. Enclosed is:

Continuation-in-Part Patent Application including:

- 11 pages of specifications
- 2 pages of drawings
- Small Entity Statement
- Combination Declaration and Power of Attorney
- Nonpublication Request
- Proof of Mailing
- Self Addressed Postcard
- A check in the amount of \$375.00

This amount is based on:

5 claim and 3 independent claim	\$375.00
0 independent claims in excess of three (\$42.00)	0.00
0 claims in excess of twenty (\$9.00)	0.00

TOTAL FILING FEE: \$375.00

Very truly yours,

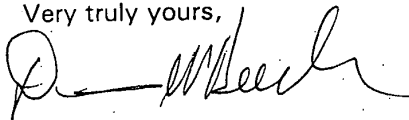

DENNIS W. BEECH  
Reg. No.: 35,443  
DWB/ab  
Enclosures



## FUZZY AUDIO WIRELESS MUSIC SYSTEM

This is a continuation-in-part of application Serial No. 10/027,739  
which patent application is pending.

5

### BACKGROUND OF THE INVENTION

[0001] This invention relates to audio player devices and more particularly to systems that include headphone listening devices. The new audio system uses existing audio player device headphone jacks to connect a battery powered transmitter for wireless transmission of a signal to a battery powered receiving headphone.

[0002] Use of audio headphones with audio player devices such as radio, tape players, CD players, computers, television audio and the like have been in use for many years. These systems usually incorporate an audio source having a headphone jack to which a headphone may be connected by wire and connector.

[0003] There are also known wireless headphones that may receive A.M. and F.M. radio transmissions. However, these systems do not allow use of a simple plug in battery powered transmitter for connection to any audio player device jack, such as, laptop and desktop computers, portable compact disc players, portable MP3 players, portable cassette players and the like, for wireless transmission and reception of audio music for private listening to multiple users occupying the same space. Existing audio systems make use of electrical wire connections between the audio source and the headphones to accomplish private listening to multiple users.

[0004] There is a need for a battery powered simple connection system for existing audio player devices, to allow wireless transmission to a headphone receiver that accomplishes private listening to multiple users occupying the same space.

30

## SUMMARY OF THE INVENTION

5 [0005] The present invention is directed to FAWM (Fuzzy Audio Wireless Music) systems for coded digital transmission of an audio signal from any audio player device with a headphone jack to a receiver headphone using fuzzy logic technology. A battery powered digital transmitter may include a headphone plug in communication with any of the previously mentioned audio sources, 10 laptop and desktop computers, portable compact disc players, portable MP3 players, portable cassette players and the like. The FAWM system converts the audio music signal that may be supplied by the source, into a digital signal. This conversion takes place in the small battery powered transmitter that connects to the headphone jack of the source. The transmitter then adds a 15 unique user code and transmits it to the battery powered receiver headphones where the fuzzy logic detector decodes only the unique user code to allow private listening without interference from other users.

[0006] These and other features, aspects and advantages of the present invention will become better understood with reference to the following 20 drawings, description and claims.

## BRIEF DESCRIPTION OF THE DRAWINGS

[0007] Figure 1 illustrates a schematic diagram representation of the 25 FAWM system;

Figure 2 illustrates a graph of the high and low bit fuzzy logic if-then part fuzzy set according to an embodiment of the invention.

30

## DETAILED DESCRIPTION

[0008] The following detailed description is the best currently contemplated modes for carrying out the invention. The description is not to be taken in a limiting sense, but is made merely for the purpose of illustrating the general principles of the invention.

[0009] Referring to Figure 1, a FAWM system 10 may include a battery powered transmitter 20 connected to a portable audio player or audio source 80. The battery powered transmitter 20 may be connected to the audio source 80 headphone jack 82 using a headphone plug 22. The battery powered transmitter 20 may have a transmitting antenna 24 that may be omni-directional for transmitting a coded digital modulated signal to a receiving antenna 52 of a battery powered receiver 50 that may be a headphone receiver. The battery powered receiver 50 may have headphone speakers 54 in headphones 55 for listening to the demodulated and decoded digital signal. The FAWM transmitter 20 may digitize the audio signal. This digital signal has a throughput of approximately 1.4 Mbps, which may be determined by the analog to digital A/D converter sampling rate of 44.1kHz multiplied by 16 bit quantization. To reduce the effects of channel noise, the battery powered transmitter 20 may use convolutional encoding, and interleaving. For further noise immunity, spread spectrum modulation may be utilized. The battery powered transmitter 20 may contain a shift register generator (SRG) that may be used to create a unique user code. The unique user code generated is specifically associated with one FAWM user, and it is the only code recognized by the battery powered FAWM headphone receiver 50 of that particular user. The radio frequency (RF) spectrum utilized (as taken from the Industrial, Scientific and Medical (ISM) band), may be approximately 2.4 GHz. And the power radiated by the transmitter adheres to the ISM standard.

[0010] Referring to Figure 1, the digital modulated signal from transmit antenna 24 may be received by receiving antenna 52 and then demodulated,

decoded and deinterleaved in the battery powered receiver 50 headphones. The battery powered receiver 50 may utilize fuzzy logic to optimize the detection of the received user code.

5 [0011] Each receiver 50 user may be able to listen (privately) to high fidelity audio music, using any of the audio devices listed previously, without the use of wires, and without interference from any other receiver 50 user. Because of the fuzzy logic detection technique used in the wireless digital audio system, user separation through code division may be achieved.

10 [0012] The battery powered transmitter 20 sends the audio information to the battery powered receiver 50 in digital packet format. Each packet may consist of, at minimum, a start bit to indicate the beginning of a packet, the unique user code, the digitized audio information and a stop bit to indicate the end of a packet. These packets may flow to create a digital bit stream rate less than or equal to 1 Mb/s.

15 [0013] The user code bits in each packet may be received and detected by a fuzzy logic detector in the headset receiver 50. For each consecutive packet received, the fuzzy logic detector may compute a conditional density with respect to the context and fuzziness of the user code vector, i.e., the received user code bits in each packet. The fuzzy logic detector is the key component to the FAWM system 10. Because the fuzzy logic detector enables the battery powered FAWM receiver 50 to accurately detect the assigned user code in the presence of noise, which includes other FAWM users. Fuzziness may describe the ambiguity of the high (1)/low (0) bit event in the noisy received packet. Note that the fuzzy detector may measure the degree to which a high/low bit occurs  
20 in the user code vector, which produces a low probability of bit error in the presence of noise. The fuzzy detector may use a set of if-then rules to map the user code bit inputs to validation outputs. These rules may be developed as if-then statements.

25 [0014] The fuzzy logic detector in the battery powered receiver 50 utilizes  
30 the if-then fuzzy set to map the received user code bits into two values; a low

(0) and a high (1). Thus, as the user code bits are received, the "if" rules map the signal bit energy to the fuzzy set low value to some degree and to the fuzzy set high value to some degree. See Figure 2. Due to additive noise each user code bit (bit energy  $x$ ) may have some membership to a low and high as represented in Figure 2. Therefore, the if-part fuzzy set may determine if each bit in the user code, for every received packet, has a greater membership to a high bit representation or a low bit representation. The more a user code bit energy,  $x$  fits into the high or low representation, the closer its subethood, i.e., a measure of the degree to which a set may be a subset of another set, may be to one. Note that Figure 2 shows that -1 equals the maximum low bit energy representation and 1 equals the maximum high bit energy representation to illustrate that this design may utilize Manchester encoding/decoding schemes.

**[0015]** The received user code input bit in each packet may be:

$x(i)$ , where  $i = 1, 2, \dots, n$  is the set of all bits that make up the user code vector.

$X(c)$ , where  $c = 1, 2, \dots, m$  represents each user assigned a unique user code.

So user  $X(1)$  has bit code  $[x(1) x(2) \dots x(n)]$  and user  $X(m)$  has bit code  $[x(1) x(2) \dots x(n)]$  which is different from user  $X(1)$ .

**[0016]** Each  $x$  in  $X$  may activate a fuzzy "if" rule. The if-part sets may be conditional densities, so the fuzzy "if" rule activates to the degree  $p[x(i)|X(c)] p[X(c)]$ , which is the probability of the user code bits  $x$  given the user vector  $X$  multiplied by the probability of  $X$ .

**[0017]** The then-part fuzzy rule set may be indirectly dependent on the input bits  $x$  in  $X$ . The then-part set may be a weighted sum equal to  $p[x(i)] p[y|x(i)]$ ,  $i = 1, 2, \dots, n$ .

**[0018]** Which is the probability of the user bit vector  $x$  multiplied by the probability of  $y$  given the user bit vector  $x$ . Where  $y$  may be a number

representation to define the correct user headset battery powered receiver 50

given the input bit set  $x(i)$ ,  $i = 1, 2, \dots, n$ .

**[0019]** The if-then rule parts that make up the fuzzy logic detector must be followed by a defuzzifying operation. This operation reduces the output fuzzy set to a single number that determines if the correct received user code bits within the transmitted packet have been detected. The defuzzifying operation may be implemented with the modal method, i.e., calculation of the value that has the highest membership in the fuzzy set. With the modal method a strategy of clarity may be applied in the event that some user code energy bit values have equally high membership. The clarity of a fuzzy set may be considered by weighting the conditional densities discussed previously. The weighting determines relative fuzziness of the user code energy bit ( $x$ ) that gives a measure of the uncertainty of the unique user code vector. As a result, the fuzzy logic detector used in the battery powered headset receiver 50 greatly reduces the unique user code bit error probability. The fuzzy logic detector technique, combined with convolutional error detection and correction techniques, may enable the FAWM system 10 to operate in most any environment.

**[0020]** While the invention has been particularly shown and described with respect to the illustrated and preferred embodiments thereof, it will be understood by those skilled in the art that the foregoing and other changes in form and details may be made therein without departing from the spirit and scope of the invention.

25

## CLAIMS

I claim:

1. A fuzzy audio wireless music system for wireless transmission of a signal from an audio source to a battery powered headphone receiver comprising:

a headphone jack from an audio source in communication with a connectable battery powered transmitter;

said connectable battery powered transmitter contains an A/D converter wherein said A/D converter converts an analog music audio signal to a digital signal at a signal rate of approximately 1.4 Mbps;

said A/D converter in communication with a shift register generator, a convolutional encoder and an interleaver;

said interleaver in communication with a spread spectrum modulator;

said spread spectrum modulator in communication with a transmit antenna for wireless transmission of a coded digital signal to a receiving antenna at a radio frequency of approximately 2.4 GHz;

said receiving antenna in communication with a spread spectrum demodulator, a convolutional deinterleaver and a decoder; and

said decoder in communication with a fuzzy logic detector.

2. The fuzzy audio wireless music system as in claim 1 wherein said battery powered headphone receiver having said fuzzy logic detector with a detection method, comprising the steps of:

a) receiving a user code having:

$x(i)$  where  $i = 1, 2, \dots, n$  is the set of all bits that make up the user code vector;

$X(c)$ , where  $c = 1, 2, \dots, m$  represents each user assigned

unique user code;

Wherein user  $X(1)$  has bit code  $[x(1) x(2) \dots X(n)]$  and user  $X(m)$  has bit code  $[x(1) x(2) \dots x(n)]$  which is different from  $X(1)$ ;

b) activating a fuzzy if rule based on each  $x$  in  $X$  wherein the if part sets are conditional densities to activate the if rule to the degree  $p[x(i)|X(c)]$   $p[X(c)]$ ;

c) activating a fuzzy then rule indirectly dependent on each  $x$  in  $X$  wherein the then part sets are a weighted sum equal to  $p[x(i)]p[y|x(i)]$ ,  $i = 1, 2, \dots, n$ ; and

d) performing a defuzzifying operation of modal type.

3. A battery powered headphone receiver having a fuzzy logic detector method, comprising the steps of:

a) receiving a user code having:

$x(i)$  where  $i = 1, 2, \dots, n$  is the set of all bits that make up the user code vector;

$X(c)$ , where  $c = 1, 2, \dots, m$  represents each user assigned unique user code;

wherein user  $X(1)$  has bit code  $[x(1) x(2) \dots X(n)]$  and user  $X(m)$  has bit code  $[x(1) x(2) \dots x(n)]$  which is different from  $X(1)$ ;

b) activating a fuzzy if rule based on each  $x$  in  $X$  wherein the if part sets are conditional densities to activate the if rule to the degree  $p[x(i)|X(c)]$   $p[X(c)]$ ;

c) activating a fuzzy then rule indirectly dependent on each  $x$  in  $X$  wherein the then part sets are a weighted sum equal to  $p[x(i)]p[y|x(i)]$ ,  $i = 1, 2, \dots, n$ ; and

d) performing a defuzzifying operation of modal type.

4. A method for battery powered digital wireless transmission and reception of high fidelity audio music between a battery operated transmitter



and a battery operated receiver comprising the step of:

connecting a headphone plug attached to said battery operated transmitter to a headphone jack of an audio source;

converting an music audio signal to a digital signal using an A/D converter having a sampling rate of approximately 44.1 kHz multiplied by 16 bit quantization to produce a signal rate of approximately 1.4 Mbps;

encoding the digital signal using a convolutional encoding and interleaving method;

creating a spread spectrum signal using a shift register generator to modulate a unique user code;

transmitting said spread spectrum signal at a radio frequency of approximately 2.4 GHz at a power level that adheres to the ISM standard for reception at a distance of up to approximately 10 feet from said battery operated transmitter;

receiving said spread spectrum signal at said battery operated receiver headphones;

demodulating said spread spectrum signal and optimal bit detecting of said unique user code using fuzzy logic technology;

convolutional decoding and deinterleaving to receive said digital signal;

converting said digital signal to said analog music audio signal;

and  
communication said analog music audio signal to a headphone speaker.

5. The battery powered receiver headphone as in claim 4 wherein said receiver having a fuzzy logic detector method comprising the steps of:

a) receiving a user code having:

$x(i)$  where  $i = 1, 2, \dots, n$  is the set of all bits that make up the user code vector;

$X(c)$ , where  $c = 1, 2, \dots, m$  represents each user assigned unique user code;

Wherein user  $X(1)$  has bit code  $[x(1) x(2) \dots x(n)]$  and user  $X(m)$  has bit code  $[x(1) x(2) \dots x(n)]$  which is different from  $X(i)$ ;

b) activating a fuzzy if rule based on each  $x$  in  $X$  wherein the if part sets are conditional densities to activate the if rule to the degree  $p[x(i)|X(c)]$   $p[X(c)]$ ;

c) activating a fuzzy then rule indirectly dependent on each  $x$  in  $X$  wherein the then part sets are a weighted sum equal to  $p[x(i)]p[y|x(i)]$ ,  $i = 1, 2, \dots, n$ ; and

d) performing a defuzzifying operation of modal type.

## FUZZY AUDIO WIRELESS MUSIC SYSTEM

### ABSTRACT OF THE DISCLOSURE

5 [0021] The fuzzy audio wireless music system may utilize a battery  
powered transmitter to transmit a coded digital signal from an audio player  
device or source to a battery powered headphone receiver without the use of  
wires. A battery powered digital transmitter may include a headphone plug in  
communication with any audio source, such as, laptop and desktop computers,  
10 portable compact disc players, portable MP3 players, portable cassette players,  
etc. The battery powered transmitter adds a unique user code and transmits it  
to the battery powered receiver headphones where a fuzzy logic detector  
decodes only the unique user code to allow private listening without  
interference from other users.

15

IN THE UNITED STATES PATENT AND TRADEMARK OFFICE

In regards to application of:

Serial Number: 10/027,391  
Applicant: C. EARL WOOLFORK  
Filing Date: 12-21-01  
Group Art Unit: 2644  
Examiner: MC CHESNEY, ELIZABETH A.  
For: WIRELESS DIGITAL AUDIO SYSTEM

Box: Non-Fee Amendment  
Assistant Commissioner for Patents  
Washington, DC 20231

CERTIFICATE OF MAILING UNDER 37 CFR § 1.10

Express Mail label number: EL 870683609 US  
Date of Deposit: November 26, 2002

I hereby certify that the following attached correspondence comprising:

8 page specifications  
1 page drawing  
Version with Markings to Show Changes Made

is being deposited with the United States Postal Service as Express Mail to Addressee" service under 37 CFR § 1.10 on the date indicated below and is addressed to:

BOX: Non-Fee Amendment  
Assistant Commissioner for Patents  
Washington, DC 20231

Date: 11-26-02

  
Annerose Beech

Law Offices of  
**DENNIS W. BEECH**

Landmark Building - Newland Center  
19900 Beach Blvd., Suite C-2  
Huntington Beach, CA 92648  
BUS: (714) 378-0212  
FAX: (714) 378-0262

**RESPOND TO: HUNTINGTON BEACH**

Palmdale/Lancaster: (661) 273-0503  
Temecula/Murrieta: (909) 986-4624  
Brea/Ontario: (909) 986-4624  
Bakersfield: (661) 821-6911  
Fax: (714) 378-0262

EXPRESS MAIL

EV482347413US

October 25, 2004

Mail Stop NON-FEE AMENDMENT  
Commissioner for Patents  
P.O. Box 1450  
Alexandria, VA 22313-1450

Serial Number: 10/648,012  
Applicant: C. Earl Woolfork  
Filing Date: 08/26/2003  
Title: WIRELESS DIGITAL AUDIO SYSTEM  
TC/AU: 2644  
Examiner: Graham, Andrew R.

**PRELIMINARY AMENDMENT**

TO THE COMMISSIONER FOR PATENTS:

The following preliminary amendment is submitted for US Patent Application No. 10/648,012 filed on 08-26-2003.

Applicant respectfully submits the following amendments to the application. Applicant believes this amendment is supported by the original disclosure and that no new matter is added by this amendment.

## **AMENDMENTS**

**Amendments to the Specification** begin on page 3 of this paper.

**Amendments to the Claims** are reflected in the listing of claims that begins on page 9 of this paper.

**Remarks/Arguments** begin on page 13 of this paper.

## **AMENDMENTS TO THE SPECIFICATION**

In the Abstract of the Disclosure: (Place a replacement or new abstract on a separate sheet)

[0021] The fuzzy audio wireless music system utilizes a battery powered **BLUETOOTH compliant** transmitter to transmit a coded ~~digital~~ **BLUETOOTH communication** signal from an ~~existing non-BLUETOOTH analog headphone jack of a music~~ audio player device or source to a battery powered **BLUETOOTH compliant** headphone receiver without the use of wires. A battery powered ~~digital~~ **BLUETOOTH compliant** transmitter may include a headphone plug in communication with a ~~standard analog headphone jack on a~~ audio source, such as, laptop and desktop computers, portable compact disc players, portable MP3 players, portable cassette players,....etc. The battery powered **BLUETOOTH compliant** transmitter adds a unique user code ~~as defined in the BLUETOOTH standard~~ and transmits it to the battery powered **BLUETOOTH compliant** receiver headphones where a fuzzy logic detector ~~detection system may be used to enhance decoding performance.~~ ~~decodes only the unique user code to~~ ~~The BLUETOOTH communication FAWM system will~~ allow private listening without interference from other users, ~~and without the inconvenience of wires.~~

In the Specifications:

Please replace the paragraphs and the beginning of the specification with the following rewritten paragraphs and beginning:

### **FUZZY AUDIO WIRELESS MUSIC SYSTEM**

This is a continuation-in-part of application Serial No. ~~40/027,739~~ 10/027,391 which patent application is pending.

### **BACKGROUND OF THE INVENTION**

[0001] This invention relates to music audio player devices and more particularly to systems that include headphone listening devices. The new audio music system uses ~~an existing device~~ non-BLUETOOTH headphone jack (~~i.e., this is the standard analog headphone jack that connects to wired headphones~~) of a music audio player (~~i.e., portable CD player, portable cassette player,~~

portable A.M./F.M. radio, laptop/desktop computer, portable MP3 player, and the like) to connect a battery powered BLUETOOTH compliant transmitter for digital wireless transmission of a BLUETOOTH communication signal to a set of battery powered BLUETOOTH compliant receiver headphones. BLUETOOTH is a worldwide wireless standard. Detailed Information regarding the standard is available on the web site www.bluetooth.com.

[0002] Use of music audio headphones with music audio player devices such as radio, tape players, CD players, computers, television audio portable CD players, portable cassette players, portable A.M./F.M. radios, laptop/desktop computer, portable MP3 players and the like, have been in use for many years. These systems incorporate an audio source having a analog non-BLUETOOTH headphone jack to which headphones may be connected by wire and connector .

[0003] There are also known non-portable wireless headphones that may receive A.M. and F.M. radio infrared (IR) transmissions. However, these systems operate with a narrow beam width that requires a point-and-shoot style for reception. these systems They do not allow use of a simple plug in (i.e., plug in to the existing analog audio headphone jack) battery powered BLUETOOTH compliant transmitter for connection to any music audio player device jack, such as, laptop and desktop computers, portable compact disc players, portable MP3 players, portable cassette players and the like, such as the above mentioned music audio player devices for coded digital wireless transmission and reception by BLUETOOTH compliant headphones of audio music for private listening to multiple users occupying the same space without the use of wires. Existing audio systems make use of electrical wire connections between the audio source and the headphones to accomplish private listening to multiple users.

[0004] There is a need for a battery powered simple connection system for existing music audio player devices (i.e., the previously mentioned music devices), to allow coded digital wireless transmission (using a battery powered BLUETOOTH compliant transmitter) to a headphone receiver (using battery powered BLUETOOTH compliant receiver headphones) that accomplishes private listening to multiple users occupying the same space without the use of wires.

#### SUMMARY OF THE INVENTION

[0005] The present invention is directed to FAWM (Fuzzy Audio Wireless Music) systems for coded digital transmission, per the BLUETOOTH standard, of an analog audio signal from any music audio player device with a non-BLUETOOTH analog headphone jack to a receiver headphone, which adheres to the BLUETOOTH standard. using Fuzzy logic technology may be



~~utilized by the FAWM system to enhance bit detection. A battery powered digital BLUETOOTH compliant transmitter may include a headphone plug in communication with any of the previously mentioned music audio sources laptop and desktop computers, portable compact disc players, portable MP3 players, portable cassette players and the like. For reception, a battery powered BLUETOOTH compliant headphone receiver may apply fuzzy logic to enhance bit detection. Fuzzy logic detection may be used to enhance bit detection during decoding of the BLUETOOTH communication signal. The FAWM system converts the audio music signal that may be supplied by the source, into a digital signal. This conversion takes place in the small battery powered transmitter that connects to the headphone jack of the source. The transmitter then adds a unique user code and transmits it to the battery powered receiver headphones where the fuzzy logic detector decodes only the unique user code to allow will provide private listening without interference from other users and without the use of wires.~~

[0006] These and other features, aspects and advantages of the present invention will become better understood with reference to the following drawings, description and claims.

#### BRIEF DESCRIPTION OF THE DRAWINGS

[0007] Figure 1 illustrates a schematic diagram representation of the FAWM system;

Figure 2 illustrates a graph of the high and low bit fuzzy logic if-then part fuzzy set according to an embodiment of the invention.

#### DETAILED DESCRIPTION

[0008] The following detailed description is the best currently contemplated modes for carrying out the invention. The description is not to be taken in a limiting sense, but is made merely for the purpose of illustrating the general principles of the invention.

[0009] Referring to Figure 1, a FAWM system 10 may include a battery powered BLUETOOTH compliant transmitter 20 connected to a portable music audio player (or music audio source) 80. The battery powered BLUETOOTH compliant transmitter 20 that utilizes a CODEC and BLUETOOTH front end may be connected to the music audio source 80 analog non-BLUETOOTH headphone jack 82 using a headphone plug 22. The battery powered BLUETOOTH compliant transmitter 20 may have a transmitting antenna 24 that may be omni-directional for transmitting a

~~coded digital spread spectrum~~ modulated signal, which adheres to the BLUETOOTH standard, to a receiving antenna 52 of a battery powered BLUETOOTH compliant headphone receiver 50. The battery powered BLUETOOTH compliant receiver 50 may have headphone speakers 54 in headphones 55 for listening to the ~~spread spectrum~~ demodulated and decoded ~~digital~~ BLUETOOTH communication signal. ~~During decoding, fuzzy logic detection may be used to increase receiver decoding performance.~~ The FAWM BLUETOOTH compliant transmitter 20 may digitize the audio signal per the BLUETOOTH standard using a CODEC and BLUETOOTH front end. This BLUETOOTH compliant digital signal has a throughput of approximately 1.4 Mbps ~~that may be as low as approximately 1.0 Mbps, which may be determined by the analog to digital A/D converter sampling rate of 44.1kHz multiplied by 16 bit quantization.~~ To reduce the effects of channel noise, the battery powered BLUETOOTH compliant transmitter 20 may use convolutional channel encoding and interleaving. For further noise immunity, spread spectrum modulation, as defined in the BLUETOOTH standard ~~may be~~ is utilized. The battery powered BLUETOOTH compliant transmitter 20 may contain a BLUETOOTH compliant shift register generator, or the like, that may be used to create a unique user code. The unique user code generated is specifically associated with one FAWM user, and it is the only code recognized by the battery powered FAWM BLUETOOTH compliant headphone receiver 50 ~~of that operated by a~~ particular user. The radio frequency (RF) spectrum utilized (as taken from the Industrial, Scientific and Medical (ISM) band), may be approximately 2.4 GHz as defined in the BLUETOOTH standard. And the power radiated by the BLUETOOTH compliant transmitter adheres to the BLUETOOTH standard.

[0010] Referring to Figure 1, the ~~digital spread spectrum~~ modulated BLUETOOTH compliant signal from transmit antenna 24 may be received by receiving antenna 52 and then ~~spread spectrum~~ demodulated per the BLUETOOTH standard, ~~decoded and deinterleaved~~ in the battery powered BLUETOOTH compliant receiver 50 headphones. The battery powered BLUETOOTH compliant receiver 50 may utilize fuzzy logic to optimize the bit detection of the received ~~packet~~ code.

[0011] Each BLUETOOTH compliant receiver headphone 50 user may be able to listen (privately) to high fidelity audio music, using any of the audio devices listed previously, without the use of wires, and without interference from any other BLUETOOTH compliant receiver headphone 50 user. . ~~Because of the fuzzy logic detection technique used in the wireless digital audio system, user separation through code division may be achieved. The fuzzy logic detection technique that may be used in the FAWM could provide greater user separation through optimizing code division in the BLUETOOTH compliant headphone receiver.~~

[0012] The battery powered BLUETOOTH compliant transmitter 20 sends the audio music

information to the battery powered BLUETOOTH compliant receiver 50 in digital packet format as defined in the BLUETOOTH standard. These packets may flow to create a digital bit stream rate of less than or equal to 1.0 Mbps as defined in the BLUETOOTH standard.

[0013] The ~~user~~ code bits in each packet may also be received and detected by a fuzzy logic detection system (as an option) in the headset receiver 50 to provide additional decoding performance. For each consecutive packet received, the fuzzy logic detection system may compute a conditional density with respect to the context and fuzziness of the ~~user~~ packet code vector, i.e., the received ~~user~~ code bits in each packet. The fuzzy logic ~~detector~~ detection system ~~is the key component to the~~ may enable the battery powered FAWM BLUETOOTH compliant system 10. ~~Because the fuzzy logic detector enables the battery powered FAWM receiver 50 to enhance the bit detection accuracy of the~~ packet code in the presence of noise, which may include other FAWM users. Fuzziness may describe the ambiguity of the high bit (1)/low bit (0 or -1) bit event in the received code within the packet. ~~Note that the~~ The fuzzy logic detection system ~~detector~~ may measure the degree to which a high/low bit occurs in the ~~user~~ packet code vector, which produces a low probability of bit error in the presence of noise. The fuzzy logic detection system may use a set of if-then rules to map the code bit inputs to validation outputs. These rules may be developed as if-then statements.

[0014] The fuzzy logic ~~detector~~ detection system in the battery powered BLUETOOTH compliant headphone receiver 50 utilizes the if-then fuzzy set to map the received ~~user~~ code bits into two values; a low (0 or -1) and a high (1). Thus, as the ~~user~~ code bits are received, the "if" rules map the signal bit energy to the fuzzy set low value to some degree and to the fuzzy set high value to some degree. See Figure 2. ~~Due to additive noise each user code bit (bit energy x) may have some membership to a low and high as represented in Figure 2. Therefore, the if-part fuzzy set may determine if each bit in the user code, for every received packet, has a greater membership to a high bit representation or a low bit representation. The more a user code bit energy, x fits into the high or low representation, the closer its subsethood, i.e., a measure of the degree to which a set may be a subset of another set, may be to one. Note that Figure 2 shows that -1 equals the maximum low bit energy representation and 1 equals the maximum high bit energy representation to illustrate that this design may utilize Manchester encoding/decoding schemes. Due to additive noise, the code bit energy may have some membership to low and high as represented in Figure 2. The if-part fuzzy set may determine if each bit in the code, for every received packet, has a greater membership to a high bit representation or a low bit representation. The more a user code bit energy fits into the high or low representation, the closer its subsethood,~~

i.e., a measure of the degree to which a set may be a subset of another set, may be to one.

[0015] The received user code input bit in each packet may be:

$x(i)$ , where  $i = 1, 2, \dots, n$  is the set of all bits that make up the user code vector.

$X(c)$ , where  $c = 1, 2, \dots, m$  represents each user assigned a unique user code.

So user  $X(1)$  has bit code  $[x(1) x(2) \dots x(n)]$  and user  $X(m)$  has bit code  $[x(1) x(2) \dots x(n)]$  which is different from user  $X(1)$ .

[0016] Each  $x$  in  $X$  may activate a fuzzy "if" rule. The if-part sets may be conditional densities, so the fuzzy "if" rule activates to the degree  $p[x(i)|X(c)] p[X(c)]$ , which is the probability of the user code bits  $x$  given the user vector  $X$  multiplied by the probability of  $X$ .

[0017] The then-part fuzzy rule set may be indirectly dependent on the input bits  $x$  in  $X$ . The then-part set may be a weighted sum equal to  $p[x(i)] p[y|x(i)]$ ,  $i = 1, 2, \dots, n$ .

[0018] Which is the probability of the user bit vector  $x$  multiplied by the probability of  $y$  given the user bit vector  $x$ . Where  $y$  may be a number representation to define the correct user headset battery powered receiver 50 given the input bit set  $x(i)$ ,  $i = 1, 2, \dots, n$ .

[0019] The if-then rule parts that make up the fuzzy logic detector detection system must be followed by a defuzzifying operation. This operation reduces the output aforementioned fuzzy set to a bit energy representation (i.e., -1 or 1) single number that determines if the correct that is received user code bits within by the transmitted BLUETOOTH standard packet. have been detected. The defuzzifying operation may be implemented with the modal method, i.e., calculation of the value that has the highest membership in the fuzzy set. With the modal method a strategy of clarity may be applied in the event that some user code energy bit values have equally high membership. The clarity of a fuzzy set may be considered by weighting the conditional densities discussed previously. The weighting determines relative fuzziness of the user code energy bit ( $x$ ) that gives a measure of the uncertainty of the unique user code vector. As a result, the fuzzy logic detector used in the battery powered headset receiver 50 greatly reduces the unique user code bit error probability. The fuzzy logic detection system may be used in the battery powered BLUETOOTH compliant headset receiver 50 to enhance overall FAWM system 10 decoding performance. The fuzzy logic detector technique, combined with convolutional error detection and correction techniques, may enable the FAWM system 10 to operate in most any environment.

[0020] While the invention has been particularly shown and described with respect to the illustrated and preferred embodiments thereof, it will be understood by those skilled in the art that the foregoing and other changes in form and details may be made therein without departing from the spirit and scope of the invention.

## **AMENDMENTS TO THE CLAIMS**

This listing of claims will replace all prior versions, and listings, of claims in the application:

### **Listing of Claims:**

1. (currently amended): A fuzzy audio wireless music system for ~~wireless transmission of a signal from~~ BLUETOOTH communication of an audio music signal from the non-BLUETOOTH analog headphone jack connected to a battery powered BLUETOOTH compliant transmitter and received by a battery powered BLUETOOTH compliant source to a battery powered headphone receiver comprising:

a ~~NON-BLUETOOTH compliant analog~~ headphone jack from an audio music source in communication with ~~a connectable~~ said battery powered BLUETOOTH compliant transmitter; said connectable battery powered BLUETOOTH compliant transmitter converts an analog audio music signal from said existing non-BLUETOOTH analog headphone jack to a BLUETOOTH compliant ~~contains an A/D converter wherein said A/D converter converts an analog music audio signal to a digital signal using a CODEC and a BLUETOOTH front end~~ at a signal rate of approximately 1.4 Mbps as defined in the BLUETOOTH standard;

~~said A/D converter~~ CODEC in communication with a shift register generator ~~that is~~ BLUETOOTH compliant to create a unique user code and a convolutional encoder ~~and an interleaver~~ ;

~~said interleaver~~ shift register generator in communication with a spread spectrum modulator ~~that is~~ BLUETOOTH compliant;

~~said~~ BLUETOOTH compliant spread spectrum modulator in communication with a transmit antenna for ~~wireless~~ BLUETOOTH compliant transmission of a coded ~~digital signal~~ BLUETOOTH compliant packet to a receiving antenna at a radio frequency of approximately 2.4 GHz as defined in the BLUETOOTH standard;

~~said~~ receiving antenna in communication with a spread spectrum demodulator ~~that is~~ BLUETOOTH compliant and a convolutional deinterleaver ~~and a decoder~~; and

~~said decoder~~ BLUETOOTH compliant spread spectrum demodulator in communication with a fuzzy logic ~~detector~~ detection system for additional decoding performance.

2. (currently amended): The fuzzy audio wireless music system as in claim 1 wherein said battery powered BLUETOOTH compliant headphone receiver having said fuzzy logic detector detection system with a detection method, comprising the steps of:

- a) receiving a user BLUETOOTH compliant packet code bits having:  
 $x(i)$  where  $i = 1, 2, \dots, n$  is the set of all bits that make up the packet user code vector;  
 ~~$X(c)$ , where  $c = 1, 2, \dots, m$  represents each user assigned unique user code; wherein user  $X(1)$  has bit code  $[x(1) x(2) \dots X(n)]$  and user  $X(m)$  has bit code  $[x(1) x(2) \dots x(n)]$  which is different form  $X(1)$ ;~~
- b) activating a fuzzy logic if rule for each bit energy in the packet code based on each  $x$  in  $X$  wherein the if part sets are conditional densities to activate the if rule to the degree  $p[x(i)|X(c)] p[X(c)]$ ;
- c) activating a fuzzy then rule indirectly dependent on each  $x$  in  $X$  wherein the then part sets are a weighted sum equal to  $p[x(i)]p[y|x(i)]$ ,  $i = 1, 2, \dots, n$  received bit energy; and
- d) performing a defuzzifying fuzzy logic operation to relate the bit energy to one of a digital one(1) and digital zero(0) bit representation. of modal type.

3. (currently amended): A battery powered BLUETOOTH compliant headphone receiver ~~possibly~~ having a an additive fuzzy logic detector detection method, comprising the steps of:

- a) receiving a user BLUETOOTH compliant packet code bits having:  
 $x(i)$  where  $i = 1, 2, \dots, n$  is the set of all bits that make up the packet user code vector;  
 ~~$X(c)$ , where  $c = 1, 2, \dots, m$  represents each user assigned unique user code; wherein user  $X(1)$  has bit code  $[x(1) x(2) \dots X(n)]$  and user  $X(m)$  has bit code  $[x(1) x(2) \dots x(n)]$  which is different form  $X(1)$ ;~~
- b) activating a fuzzy logic if rule for each bit energy in the packet code  $x$  in  $X$  wherein the if part sets are conditional densities to activate the if rule to the degree  $p[x(i)|X(c)] p[X(c)]$ ;
- c) activating a fuzzy then rule indirectly dependent on each  $x$  in  $X$  wherein the

~~then part sets are a weighted sum equal to  $p[x(i)]p[y|x(i)]$ ,  $i = 1, 2, \dots, n$  received bit energy; and~~

d) ~~performing a defuzzifying fuzzy logic operation to relate the bit energy to one of a digital one(1) and digital zero(0) bit representation. operation of modal type:~~

4. (currently amended): A method for battery powered digital wireless BLUETOOTH communication transmission and reception of high fidelity audio music between a battery operated BLUETOOTH compliant transmitter and a battery operated BLUETOOTH compliant receiver headphone comprising the step of:

connecting the plug attached to said battery operated BLUETOOTH compliant transmitter to ~~a~~ the existing non-BLUETOOTH compliant analog headphone jack of an audio music source;

converting ~~an a~~ music audio signal to a digital BLUETOOTH communication signal using an AVD converter having a sampling rate of approximately 44.1 kHz multiplied by 16 bit quantization to produce a signal rate of approximately 1.4 Mbps a CODEC and a BLUETOOTH front end;

encoding the digital BLUETOOTH communication signal using a convolutional BLUETOOTH standard convolutional encoding and interleaving method;

creating a BLUETOOTH standard spread spectrum signal using a shift register generator to modulate a unique user code that adheres to the BLUETOOTH standard;

transmitting said BLUETOOTH standard spread spectrum signal at a radio frequency of approximately 2.4 GHz at a power level that adheres to the ISM BLUETOOTH standard for reception at a distance ~~of up to 10 less than~~ approximately 30 feet from said battery operated BLUETOOTH compliant transmitter;

receiving said BLUETOOTH compliant spread spectrum signal at said battery operated BLUETOOTH compliant receiver headphones;

demodulating said BLUETOOTH compliant spread spectrum signal; ~~and optimal bit detecting of said unique user code using fuzzy logic technology~~;

~~convolutional decoding and deinterleaving to receive said digital signal; decoding of said BLUETOOTH communication signal as defined in the BLUETOOTH standard, with an option to apply fuzzy logic detection system to enhance bit detection performance~~;

converting said digital BLUETOOTH communication signal back to said analog music audio signal; and

communication said analog music audio signal to a headphone speaker within the

BLUETOOTH compliant headphone receiver.

5. (currently amended): The ~~battery powered receiver headphone method~~ as in claim 4. wherein said ~~battery operated BLUETOOTH compliant receiver~~ having a fuzzy logic detector method comprising the steps of:

- a) receiving ~~a user BLUETOOTH compliant packet code bits~~ having:  
 $x(i)$  where  $i = 1, 2, \dots, n$  is the set of all bits that make up the ~~packet user code vector~~;  
 $X(c)$ , where  $c = 1, 2, \dots, m$  represents ~~each user assigned unique user code~~;  
wherein ~~user  $X(1)$  has bit code  $[x(1) x(2) \dots X(n)]$  and user  $X(m)$  has bit code  $[x(1) x(2) \dots x(n)]$  which is different from  $X(1)$ ;~~
- b) ~~activating a fuzzy logic if rule for each bit energy in the packet code based on each  $x$  in  $X$  wherein the if part sets are conditional densities to activate the if rule to the degree  $p[x(i)|X(c)] p[X(c)]$ ;~~
- c) ~~activating a fuzzy then rule indirectly dependent on each  $x$  in  $X$  wherein the then part sets are a weighted sum equal to  $p[x(i)] p[y|x(i)]$ ,  $i = 1, 2, \dots, n$  received bit energy; and~~
- d) ~~performing a defuzzifying fuzzy logic operation to relate the bit energy to one of a digital one(1) and digital zero(0) bit representation. operation of modal type.~~



**REMARKS/ARGUMENTS**

The applicant has provided the following analysis concerning non-introduction of new matter for this preliminary amendment.

"A Special Interest Group (SIG) was formed to create an industry standard for short range low power radio frequency (RF) connectivity to make free use of intellectual property in a specification. The specification is called Bluetooth. The SIG determined a short range low power RF protocol for personal wireless connectivity technologies that allow personal devices to communicate. The Bluetooth wireless technology serves as a replacement of the interconnecting cables between personal electronic devices. Because the FAWM design replaces the interconnecting cable between a portable audio music device and a pair of headphones, it was necessary to follow the Bluetooth specification to adhere to the RF, low power wireless protocol.

In the initial patent application and the CIP the Bluetooth protocol was described, but the name (Bluetooth) was not called out. The key Bluetooth specifications are as follows: The (1) carrier frequency of approximately 2.4 GHz is in the ISM (Industrial, Scientific, & Medical) band, and the (2) data rate is approximately 1 Mbps. The (3) transmit power is not greater than 100 mW (milliwatts), and has a (4) operating range up to 30 ft (or 10 m). To correct errors that may occur during packet transmission, (5) convolutional encoding is used. Finally, (6) spread spectrum technology is used for maximum immunity to interference.

Each of the Bluetooth specifications listed has been included in the initial patent application and the CIP".

No additional fee for claims is seen to be required.

If you have any questions do not hesitate to contact me.

Very truly yours,

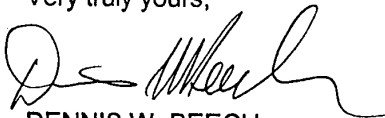

DENNIS W. BEECH  
Reg. No.: 35,443

DWB/ab

IN THE UNITED STATES PATENT AND TRADEMARK OFFICE

In regards to application of:

Serial Number: 10/648,012  
Applicant: C. Earl Woolfork  
Filing Date: 08/26/2003  
Title: WIRELESS DIGITAL AUDIO SYSTEM  
TC/AU: 2644  
Examiner: Graham, Andrew R.

Mail Stop Non-Fee Amendment  
Commissioner for Patents  
P.O. Box 1450  
Alexandria, VA 22313-1450

-----  
**EXPRESS MAIL CERTIFICATE MAILING UNDER 37 CFR § 1.10**

"Express Mail" label number: EV 482347413 US

Date of Deposit: October 25, 2004

I hereby certify that the following attached correspondence comprising:

13 Pages of response

is being deposited with the United States Postal Service "Express Mail Post Office to Addressee" service under 37 CFR § 1.10 on the date indicated above and is addressed to:

Mail Stop Non-Fee Amendment  
Commissioner for Patents  
P.O. Box 1450  
Alexandria, VA 22313-1450

Date: 10-25-04

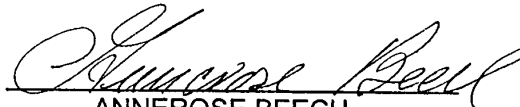
  
ANNEROSE BEECH

**DECLARATION FOR PATENT APPLICATION**

My name is Dennis W. Beech. I am a registered patent attorney who represented C. Earl Woolfork in the filing of a continuation-in-part application serial no. 10/648,012 ("the '012 application"). The '012 application was submitted to the United States Patent and Trademark Office on or about August 25, 2003. I represented C. Earl Woolfork in relation to the '012 application from the date of submission of the '012 application until on or about July 25, 2005.

On the date of submission of the '012 application, a typographical error was made with respect to the application serial number in the first line of the specification. The first line of the specification provided that the '012 application claimed the benefit of priority of U.S. patent application serial no. 10/027,739. The '012 application was intended to include a priority claim to U.S. patent application serial no. 10/027,391. A preliminary amendment was submitted to this effect on or about October 25, 2004.

The entire delay between the date the claim was due and the date the claim was filed was unintentional.

I declare that all statements made herein of my own knowledge are true and that all statements made on information and belief are believed to be true; and further that these statements were made with the knowledge that willful false statements and the like so made are punishable by fine or imprisonment, or both, under Section 1001 of Title 18 of the United States Code and that such willful false statements may jeopardize the validity of the application or any patent issued thereon.

Full name of Declarant <i>Dennis W. Beech</i>	Declarant's signature <i>D. W. Beech</i>	Date <i>8/29/2005</i>
Residence and Post Office Address <i>P.O. Box 519, Muhieta, CA 92564</i>		Citizenship <i>US</i>

WJH



UNITED STATES PATENT AND TRADEMARK OFFICE

UNITED STATES DEPARTMENT OF COMMERCE  
United States Patent and Trademark Office  
Address: COMMISSIONER FOR PATENTS  
P.O. Box 1450  
Alexandria, Virginia 22313-1450  
www.uspto.gov

APPLICATION NO.	FILING DATE	FIRST NAMED INVENTOR	ATTORNEY DOCKET NO.	CONFIRMATION NO.
10/648,012	08/26/2003	C. Earl Woolfork	73785-014	3337

7590 09/07/2005  
ATTN: Daphne L. Burton  
McDERMOTT, WILL & EMERY, LLP  
34th Floor  
2049 Century Park East  
Los Angeles, CA 90067

EXAMINER

GRAHAM, ANDREW R

ART UNIT PAPER NUMBER

2644

DATE MAILED: 09/07/2005

Please find below and/or attached an Office communication concerning this application or proceeding.

<b>Interview Summary</b>	<b>Application No.</b> 10/648,012	<b>Applicant(s)</b> WOOLFORK, C. EARL	
	<b>Examiner</b> Andrew Graham	<b>Art Unit</b> 2644	

All participants (applicant, applicant's representative, PTO personnel):

(1) Andrew Graham.

(3) E. Woolfork.

(2) Laura Grier.

(4) D. Burton.

Date of Interview: 24 August 2005.

Type: a)  Telephonic    b)  Video Conference  
c)  Personal [copy given to: 1)  applicant    2)  applicant's representative]

Exhibit shown or demonstration conducted: d)  Yes    e)  No.  
If Yes, brief description: \_\_\_\_\_.

Claim(s) discussed: 1, 4, 6 and 7.

Identification of prior art discussed: n/a.

Agreement with respect to the claims f)  was reached.    g)  was not reached.    h)  N/A.

Substance of Interview including description of the general nature of what was agreed to if an agreement was reached, or any other comments: See Continuation Sheet.

(A fuller description, if necessary, and a copy of the amendments which the examiner agreed would render the claims allowable, if available, must be attached. Also, where no copy of the amendments that would render the claims allowable is available, a summary thereof must be attached.)

THE FORMAL WRITTEN REPLY TO THE LAST OFFICE ACTION MUST INCLUDE THE SUBSTANCE OF THE INTERVIEW. (See MPEP Section 713.04). If a reply to the last Office action has already been filed, APPLICANT IS GIVEN ONE MONTH FROM THIS INTERVIEW DATE, OR THE MAILING DATE OF THIS INTERVIEW SUMMARY FORM, WHICHEVER IS LATER, TO FILE A STATEMENT OF THE SUBSTANCE OF THE INTERVIEW. See Summary of Record of Interview requirements on reverse side or on attached sheet.

  
**VIVIAN CHIN**  
**SUPERVISORY PATENT EXAMINER**  
**TECHNOLOGY CENTER 2600**

  
8-24-05

Examiner Note: You must sign this form unless it is an Attachment to a signed Office action.

  
\_\_\_\_\_  
Examiner's signature, if required

## Summary of Record of Interview Requirements

### • Manual of Patent Examining Procedure (MPEP), Section 713.04, Substance of Interview Must be Made of Record

A complete written statement as to the substance of any face-to-face, video conference, or telephone interview with regard to an application must be made of record in the application whether or not an agreement with the examiner was reached at the interview.

### Title 37 Code of Federal Regulations (CFR) § 1.133 Interviews Paragraph (b)

In every instance where reconsideration is requested in view of an interview with an examiner, a complete written statement of the reasons presented at the interview as warranting favorable action must be filed by the applicant. An interview does not remove the necessity for reply to Office action as specified in §§ 1.111, 1.135. (35 U.S.C. 132)

### 37 CFR §1.2 Business to be transacted in writing.

All business with the Patent or Trademark Office should be transacted in writing. The personal attendance of applicants or their attorneys or agents at the Patent and Trademark Office is unnecessary. The action of the Patent and Trademark Office will be based exclusively on the written record in the Office. No attention will be paid to any alleged oral promise, stipulation, or understanding in relation to which there is disagreement or doubt.

The action of the Patent and Trademark Office cannot be based exclusively on the written record in the Office if that record is itself incomplete through the failure to record the substance of interviews.

It is the responsibility of the applicant or the attorney or agent to make the substance of an interview of record in the application file, unless the examiner indicates he or she will do so. It is the examiner's responsibility to see that such a record is made and to correct material inaccuracies which bear directly on the question of patentability.

Examiners must complete an Interview Summary Form for each interview held where a matter of substance has been discussed during the interview by checking the appropriate boxes and filling in the blanks. Discussions regarding only procedural matters, directed solely to restriction requirements for which interview recordation is otherwise provided for in Section 812.01 of the Manual of Patent Examining Procedure, or pointing out typographical errors or unreadable script in Office actions or the like, are excluded from the interview recordation procedures below. Where the substance of an interview is completely recorded in an Examiners Amendment, no separate Interview Summary Record is required.

The Interview Summary Form shall be given an appropriate Paper No., placed in the right hand portion of the file, and listed on the "Contents" section of the file wrapper. In a personal interview, a duplicate of the Form is given to the applicant (or attorney or agent) at the conclusion of the interview. In the case of a telephone or video-conference interview, the copy is mailed to the applicant's correspondence address either with or prior to the next official communication. If additional correspondence from the examiner is not likely before an allowance or if other circumstances dictate, the Form should be mailed promptly after the interview rather than with the next official communication.

The Form provides for recordation of the following information:

- Application Number (Series Code and Serial Number)
- Name of applicant
- Name of examiner
- Date of interview
- Type of interview (telephonic, video-conference, or personal)
- Name of participant(s) (applicant, attorney or agent, examiner, other PTO personnel, etc.)
- An indication whether or not an exhibit was shown or a demonstration conducted
- An identification of the specific prior art discussed
- An indication whether an agreement was reached and if so, a description of the general nature of the agreement (may be by attachment of a copy of amendments or claims agreed as being allowable). Note: Agreement as to allowability is tentative and does not restrict further action by the examiner to the contrary.
- The signature of the examiner who conducted the interview (if Form is not an attachment to a signed Office action)

It is desirable that the examiner orally remind the applicant of his or her obligation to record the substance of the interview of each case. It should be noted, however, that the Interview Summary Form will not normally be considered a complete and proper recordation of the interview unless it includes, or is supplemented by the applicant or the examiner to include, all of the applicable items required below concerning the substance of the interview.

A complete and proper recordation of the substance of any interview should include at least the following applicable items:

- 1) A brief description of the nature of any exhibit shown or any demonstration conducted,
- 2) an identification of the claims discussed,
- 3) an identification of the specific prior art discussed,
- 4) an identification of the principal proposed amendments of a substantive nature discussed, unless these are already described on the Interview Summary Form completed by the Examiner,
- 5) a brief identification of the general thrust of the principal arguments presented to the examiner,  
(The identification of arguments need not be lengthy or elaborate. A verbatim or highly detailed description of the arguments is not required. The identification of the arguments is sufficient if the general nature or thrust of the principal arguments made to the examiner can be understood in the context of the application file. Of course, the applicant may desire to emphasize and fully describe those arguments which he or she feels were or might be persuasive to the examiner.)
- 6) a general indication of any other pertinent matters discussed, and
- 7) if appropriate, the general results or outcome of the interview unless already described in the Interview Summary Form completed by the examiner.

Examiners are expected to carefully review the applicant's record of the substance of an interview. If the record is not complete and accurate, the examiner will give the applicant an extendable one month time period to correct the record.

### Examiner to Check for Accuracy

If the claims are allowable for other reasons of record, the examiner should send a letter setting forth the examiner's version of the statement attributed to him or her. If the record is complete and accurate, the examiner should place the indication, "Interview Record OK" on the paper recording the substance of the interview along with the date and the examiner's initials.

Continuation of Substance of Interview including description of the general nature of what was agreed to if an agreement was reached, or any other comments: Formal matters regarding the application and application process were discussed, including the notice of not-acceptable notice of appeal of 8/16/05; claims have not been twice rejected because benefit of parent case has not been granted, per an untimely claim for benefit under 37 CFR 1.78; current and potential amendments to claims were also discussed in terms of their effect on the scope of the claims, though it was noted that such current and/or potential amendments would require further search. No agreement was reached regarding the status of the currently amended claims.

Customer No. 33401

Attorney Docket No. 073758-0013

**RECEIVED**  
**CENTRAL FAX CENTER**  
OCT 07 2005

**IN THE UNITED STATES PATENT AND TRADEMARK OFFICE**

In re Application of: C. Earl Woolfork  Serial No.: 10/648,012  Filed: August 26, 2003  For: WIRELESS DIGITAL AUDIO SYSTEM	Group Art Unit: 2644  Examiner: Andrew R. Graham
---	--

**CERTIFICATE OF FACSIMILE TRANSMISSION UNDER 37 C.F.R. § 1.6(d)**

I hereby certify that this correspondence is being transmitted via facsimile to 571-273-8300 under 37 CFR 1.6(d) on the date below.

Date: 10/7/05   
 Anita Chou

Commissioner for Patents  
 P.O. Box 1450  
 Alexandria, VA 22313-1450

**TELEPHONE INTERVIEW SUMMARY**

Sir:

The courtesy extended by Examiner Graham and a primary examiner during a telephone conversation held on August 24, 2005 is appreciated. During the telephone discussion, Examiner Graham indicated that he had not yet searched the claims presented via preliminary amendment on or about July 1, 2005. Accordingly, no agreement was reached as to the claims. Moreover, Examiner Graham indicated that the notice of appeal had been deemed defective because the priority claim (made by Applicant's prior attorney) had been unintentionally delayed.

It is believed that no extension of time is needed. However, in case an extension of time is needed, to the extent necessary, a petition for an extension of time under 37

LAS99 1412492-1.073785.0013



Serial No.: 10/648,012

Attorney Docket No.: 073758-0013

C.F.R. 1.136 is hereby made. Please charge any shortage in fees due in connection with the filing of this paper, including extension of time fees, to Deposit Account 501946 and please credit any excess fees to such deposit account.

Respectfully submitted,

MCDERMOTT, WILL & EMERY LLP

Respectfully submitted,

October 7, 2005  
Date

Daphne L. Burton  
Daphne L. Burton  
Registration No. 45,323

MCDERMOTT WILL & EMERY LLP  
2049 Century Park East, 34th Floor  
Los Angeles, CA 90067  
Telephone: (310) 277-4110  
Facsimile: (310) 277-4730



UNITED STATES PATENT AND TRADEMARK OFFICE

Commissioner for Patents  
United States Patent and Trademark Office  
P.O. Box 1450  
Alexandria, VA 22313-1450  
www.uspto.gov

ATTN: DAPHNE L. BURTON  
MCDERMOTT, WILL & EMERY, LLP  
34TH FLOOR  
2049 CENTURY PARK EAST  
LOS ANGELES, CA 90067

**COPY MAILED**

NOV 10 2005

**OFFICE OF PETITIONS**

In re Application of	:	
C. Earl Woolfork	:	
Application No. 10/648,012	:	DECISION ON PETITION
Filed: August 26, 2003	:	UNDER 37 CFR 1.78(a)(3)
Attorney Docket No. 73785-012	:	

This is a decision on the petition under 37 CFR 1.78(a)(3), filed August 31, 2005, to accept an unintentionally delayed claim under 35 U.S.C. 120 for the benefit of priority to the prior-filed nonprovisional application set forth in the amendment filed October 25, 2004 and again on July 1, 2005.

The petition is **GRANTED**.

A petition for acceptance of a claim for late priority under 37 CFR 1.78(a)(3) is only applicable to those applications filed on or after November 29, 2000. Further, the petition is appropriate only after the expiration of the period specified in 37 CFR 1.78(a)(2)(ii). In addition, the petition under 37 CFR 1.78(a)(3) must be accompanied by:

- (1) the reference required by 35 U.S.C. § 120 and 37 CFR 1.78(a)(2)(i) of the prior-filed application, unless previously submitted;
- (2) the surcharge set forth in § 1.17(t); and
- (3) a statement that the entire delay between the date the claim was due under 37 CFR 1.78(a)(2)(ii) and the date the claim was filed was unintentional. The Commissioner may require additional information where there is a question whether the delay was unintentional.

The instant nonprovisional application was filed after November 29, 2000, and the claim herein for the benefit of priority to the prior-filed nonprovisional application is submitted after expiration of the period specified in 37 CFR 1.78(a)(2)(ii). Therefore, this is a proper petition under 37 CFR 1.78(a)(3).

The petition complies with the requirements for a grantable petition under 37 CFR 1.78(a)(3) in that (1) a reference to the prior-filed nonprovisional application has been included in an amendment to the first sentence of the specification following the title, as provided by 37 CFR 1.78(a)(2)(iii); (2) the surcharge fee required by 37 CFR 1.17(t) has been submitted; and (3) the petition contains a proper statement of unintentional delay. Accordingly, having found that the instant petition for acceptance of an unintentionally delayed claim for the benefit of priority under 35 U.S.C. § 120 to the prior-filed nonprovisional application satisfies the conditions of 37 CFR 1.78(a)(3), the petition is granted.

**The granting of the petition to accept the delayed benefit claim to the prior-filed application under 37 CFR 1.78(a)(3) should not be construed as meaning that the instant application is entitled to the benefit of the prior-filed application. In order for the instant application to be entitled to the benefit of the prior-filed application, all other requirements under 35 U.S.C. 120 and 37 CFR 1.78(a)(1) and (a)(2) must be met. Similarly, the fact that the corrected Filing Receipt accompanying this decision on petition includes the prior-filed application should not be construed as meaning that applicant is entitled to the claim for benefit of priority to the prior-filed application noted thereon. Accordingly, the examiner will, in due course, consider this benefit claim and determine whether the instant application is entitled to the benefit of the earlier filing date.**

A corrected Filing Receipt, which includes the priority claim to the prior-filed nonprovisional application, accompanies this decision on petition.

This application is being forwarded to Technology Center Art Unit 2644 for consideration by the examiner of applicant's entitlement to claim benefit of priority under 35 U.S.C. § 120 to the prior-filed nonprovisional application.

Any inquiries concerning this decision may be directed to the Petitions Attorney Edward Tannouse at (571) 272-3228. All other inquiries concerning either the examination procedures or status of the application should be directed to the Technology Center.



Frances Hicks  
Petitions Examiner  
Office of Petitions  
Office of the Deputy Commissioner  
for Patent Examination Policy

**ATTACHMENT:** Corrected Filing Receipt

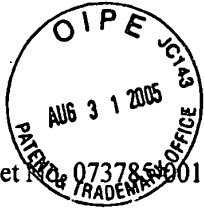

Docket No. 073785.0013

PATENT

DAE  
JFW

IN THE UNITED STATES PATENT AND TRADEMARK OFFICE

In re Application of	:	Customer Number: 33401
	:	
C. Earl WOOLFORK	:	Confirmation Number: 3337
	:	
Application No.: 10/648,012	:	Group Art Unit: 2644
	:	
Filed: August 26, 2003	:	Examiner: Graham, Andrew
	:	
For: WIRELESS DIGITAL AUDIO SYSTEM	:	

PETITION FOR UNINTENTIONALLY DELAYED CLAIM FOR § 120 PRIORITY UNDER 37 C.F.R. § 1.78(a)(3)

Mail Stop Petition  
Commissioner for Patents  
P.O. Box 1450  
Alexandria, VA 22313-1450

Dear Sir:

Applicant respectfully requests acceptance of the revised priority claim in the above identified application.

U.S. Application No. 10/648,012 (hereinafter '012 application), filed on or about August 26, 2003, was filed as an utility application pursuant to 37 C.F.R. 1.53(b). As evident from the transmittal sheet (Exhibit A) submitted at the time the '012 application was filed, Applicant identified the '012 application as a continuation-in-part for U.S. Application No. 10/027,391 (hereinafter '391 application) filed on December 21, 2001.

However, in the continuation-in-part application dated August 25, 2003, which was the subject of the transmittal sheet, the priority claim provided the incorrect serial no. (Exhibit B) which inadvertently identified the '012 application as a continuation-in-part of serial no. 10/027, 739, rather than a continuation-in-part of the '391 application. Accordingly, the '391 application was not correctly identified in the specification as a prior U.S. application with benefit claimed

09/01/2005	TBESHARI	00000013	501946	0110648012	Adjustment date: 11/10/2005	AKELLEY
01 FC:1454	1370.00	DA			09/01/2005	MBERHE 00000098 501946 10648012
	LAS99	1417278-1.073785.0013			01 FC:1454	1370.00 CR

UNITED STATES PATENT & TRADEMARK OFFICE  
Washington, D.C. 20231

REQUEST FOR PATENT FEE REFUND										
1 Date of Request: <u>11/8/05</u>		2 Serial/Patent # <u>10/648,012</u>								
3 Please refund the following fee(s):		4 PAPER NUMBER	5 DATE FILED							
<input type="checkbox"/>	Filing		\$							
<input type="checkbox"/>	Amendment		\$							
<input type="checkbox"/>	Extension of Time		\$							
<input type="checkbox"/>	Notice of Appeal/Appeal		\$							
<input checked="" type="checkbox"/>	Petition		8/31/05 \$ 1370							
<input type="checkbox"/>	Issue		\$							
<input type="checkbox"/>	Cert of Correction/Terminal Disc.		\$							
<input type="checkbox"/>	Maintenance		\$							
<input type="checkbox"/>	Assignment		\$							
<input type="checkbox"/>	Other		\$							
		7 TOTAL AMOUNT OF REFUND								
		\$ 1370								
10 REASON:		8 TO BE REFUNDED BY:								
<input type="checkbox"/>	Overpayment	Treasury Check								
<input checked="" type="checkbox"/>	Duplicate Payment	<input checked="" type="checkbox"/> Credit Deposit A/C #:								
<input type="checkbox"/>	No Fee Due (Explanation):	9 <table border="1" style="display: inline-table; border-collapse: collapse;"> <tr> <td style="width: 20px; height: 20px;">5</td> <td style="width: 20px; height: 20px;">0</td> <td style="width: 20px; height: 20px;">--</td> <td style="width: 20px; height: 20px;">1</td> <td style="width: 20px; height: 20px;">9</td> <td style="width: 20px; height: 20px;">4</td> <td style="width: 20px; height: 20px;">6</td> </tr> </table>		5	0	--	1	9	4	6
5	0	--	1	9	4	6				
11 REFUND REQUESTED BY:										
TYPED/PRINTED NAME: <u>Ed. Tanrose</u>		TITLE: <u>Per. Asst</u>								
SIGNATURE: <u>[Signature]</u>		PHONE: <u>23228</u>								
OFFICE: <u>4700</u>										
***** THIS SPACE RESERVED FOR FINANCE USE ONLY: *****										
APPROVED: <u>[Signature]</u>		DATE: <u>11/10/05</u>								

*Instructions for completion of this form appear on the back. After completion, attach white and yellow copies to the official file and mail or hand-carry to:*

Office of Finance  
Refund Branch  
Crystal Park One, Room S02B



UNITED STATES PATENT AND TRADEMARK OFFICE

UNITED STATES DEPARTMENT OF COMMERCE
United States Patent and Trademark Office
Address: COMMISSIONER FOR PATENTS
P.O. Box 1450
Alexandria, Virginia 22313-1450
www.uspto.gov



Bib Data Sheet

CONFIRMATION NO. 3337

Table with 5 columns: SERIAL NUMBER (10/648,012), FILING OR 371(c) DATE (08/26/2003), CLASS (700), GROUP ART UNIT (2644), ATTORNEY DOCKET NO. (73785-014)

APPLICANTS
C. Earl Woolfork, Pasadena, CA;
\*\* CONTINUING DATA \*\*\*\*\*
This application is a CIP of 10/027,391 12/21/2001 ABN
\*\* FOREIGN APPLICATIONS \*\*\*\*\*
IF REQUIRED, FOREIGN FILING LICENSE GRANTED\*\* SMALL ENTITY \*\*
\*\* 11/18/2003

Table with 6 columns: Foreign Priority claimed (yes/no), 35 USC 119 (a-d) conditions met (yes/no/Met after Allowance), STATE OR COUNTRY (CA), SHEETS DRAWING (2), TOTAL CLAIMS (5), INDEPENDENT CLAIMS (3)

ADDRESS
ATTN: Daphne L. Burton
McDERMOTT, WILL & EMERY, LLP
34th Floor
2049 Century Park East
Los Angeles ,CA 90067

TITLE
WIRELESS DIGITAL AUDIO MUSIC SYSTEM

Table with 2 columns: FILING FEE RECEIVED (375) and FEES: Authority has been given in Paper No. to charge/credit DEPOSIT ACCOUNT No. for following: (List of fee options: All Fees, 1.16 Fees, 1.17 Fees, 1.18 Fees, Other, Credit)

Docket No.: 73785-013

**PATENT RECEIVED**  
**CENTRAL FAX CENTER**

**IN THE UNITED STATES PATENT AND TRADEMARK OFFICE**

**NOV 17 2005**

In re Application of:  
C. Earl Woolfork

Serial No.: 10/648,012

Filed: August 26, 2003

For: WIRELESS DIGITAL AUDIO  
MUSIC SYSTEM

CERTIFICATE OF FACSIMILE TRANSMISSION  
UNDER 37 C.F.R. § 1.6(d)

I hereby certify that this correspondence is  
being transmitted via facsimile to Mail Stop:  
OIPE, at 571-273-8300 under 37 CFR 1.6(d) on  
November 17, 2005.



Anita Chou

Mail Stop: OIPE  
Commissioner for Patents  
P.O. Box 1450  
Alexandria, VA 22313-1450

**REQUEST FOR CORRECTED FILING RECEIPT**

Sir:

Attached is a copy of the Filing Receipt received from the U.S. Patent and Trademark Office in the above-referenced application. Please change the attorney docket number from 73785-014 to 73785-013.

Attached is a copy of the filing receipt with the changes noted thereon. It is requested that a corrected filing receipt be issued.

Respectfully submitted,

November 17, 2005

Date



Daphne L. Burton  
Registration No. 45,323

McDERMOTT, WILL & EMERY, LLP  
2049 Century Park East, 34th Floor  
Los Angeles, CA 90067  
Telephone: (310) 277-4110  
Facsimile: (310) 277-4730

**RECEIVED**  
NOV 15 2005



UNITED STATES PATENT AND TRADEMARK OFFICE

UNITED STATES DEPARTMENT OF COMMERCE  
United States Patent and Trademark Office  
Address: COMMISSIONER FOR PATENTS  
P.O. Box 1450  
Alexandria, Virginia 22313-1450  
www.uspto.gov

APPL NO.	FILING OR 371 (c) DATE	ART UNIT	FIL FEE REC'D	ATTY. DOCKET NO	DRAWINGS	TOT CLMS	IND CLMS
10/648,012	08/26/2003	2644	375	<del>79785-014</del> 13785-013	2	5	3

ATTN: Daphne L. Burton  
McDERMOTT, WILL & EMERY, LLP  
34th Floor  
2049 Century Park East  
Los Angeles, CA 90067

CONFIRMATION NO. 3337

CORRECTED FILING RECEIPT  
\*OC00000017423840\*

Date Mailed: 11/09/2005

Receipt is acknowledged of this regular Patent Application. It will be considered in its order and you will be notified as to the results of the examination. Be sure to provide the U.S. APPLICATION NUMBER, FILING DATE, NAME OF APPLICANT, and TITLE OF INVENTION when inquiring about this application. Fees transmitted by check or draft are subject to collection. Please verify the accuracy of the data presented on this receipt. If an error is noted on this Filing Receipt, please mail to the Commissioner for Patents P.O. Box 1450 Alexandria Va 22313-1450. Please provide a copy of this Filing Receipt with the changes noted thereon. If you received a "Notice to File Missing Parts" for this application, please submit any corrections to this Filing Receipt with your reply to the Notice. When the USPTO processes the reply to the Notice, the USPTO will generate another Filing Receipt incorporating the requested corrections (if appropriate).

**Applicant(s)**

C. Earl Woolfork, Pasadena, CA;

**Power of Attorney:** The patent practitioners associated with Customer Number 33401.

**Domestic Priority data as claimed by applicant**

This application is a CIP of 10/027,391 12/21/2001 ABN

**Foreign Applications**

If Required, Foreign Filing License Granted: 11/18/2003

The country code and number of your priority application, to be used for filing abroad under the Paris Convention, is **US10/648,012**

**Projected Publication Date:** Request for Non-Publication Acknowledged

**Non-Publication Request:** Yes

**Early Publication Request:** No

**\*\* SMALL ENTITY \*\***



## Title

WIRELESS DIGITAL AUDIO MUSIC SYSTEM

## Preliminary Class

700

**BEST AVAILABLE COPY****PROTECTING YOUR INVENTION OUTSIDE THE UNITED STATES**

Since the rights granted by a U.S. patent extend only throughout the territory of the United States and have no effect in a foreign country, an inventor who wishes patent protection in another country must apply for a patent in a specific country or in regional patent offices. Applicants may wish to consider the filing of an international application under the Patent Cooperation Treaty (PCT). An international (PCT) application generally has the same effect as a regular national patent application in each PCT-member country. The PCT process simplifies the filing of patent applications on the same invention in member countries, but does not result in a grant of "an international patent" and does not eliminate the need of applicants to file additional documents and fees in countries where patent protection is desired.

Almost every country has its own patent law, and a person desiring a patent in a particular country must make an application for patent in that country in accordance with its particular laws. Since the laws of many countries differ in various respects from the patent law of the United States, applicants are advised to seek guidance from specific foreign countries to ensure that patent rights are not lost prematurely.

Applicants also are advised that in the case of inventions made in the United States, the Director of the USPTO must issue a license before applicants can apply for a patent in a foreign country. The filing of a U.S. patent application serves as a request for a foreign filing license. The application's filing receipt contains further information and guidance as to the status of applicant's license for foreign filing.

Applicants may wish to consult the USPTO booklet, "General Information Concerning Patents" (specifically, the section entitled "Treaties and Foreign Patents") for more information on timeframes and deadlines for filing foreign patent applications. The guide is available either by contacting the USPTO Contact Center at 800-786-9199, or it can be viewed on the USPTO website at <http://www.uspto.gov/web/offices/pac/doc/general/index.html>.

For information on preventing theft of your intellectual property (patents, trademarks and copyrights), you may wish to consult the U.S. Government website, <http://www.stopfakes.gov>. Part of a Department of Commerce initiative, this website includes self-help "toolkits" giving innovators guidance on how to protect intellectual property in specific countries such as China, Korea and Mexico. For questions regarding patent enforcement issues, applicants may call the U.S. Government hotline at 1-866-999-HALT (1-866-999-4158).

---

**LICENSE FOR FOREIGN FILING UNDER  
Title 35, United States Code, Section 184  
Title 37, Code of Federal Regulations, 5.11 & 5.15**

**GRANTED**

The applicant has been granted a license under 35 U.S.C. 184, if the phrase "IF REQUIRED, FOREIGN FILING LICENSE GRANTED" followed by a date appears on this form. Such licenses are issued in all applications where the conditions for issuance of a license have been met, regardless of whether or not a license may be required as set forth in 37 CFR 5.15. The scope and limitations of this license are set forth in 37 CFR 5.15(a) unless an earlier license has been issued under 37 CFR 5.15(b). The license is subject to revocation upon written notification. The date indicated is the effective date of the license, unless an earlier license of similar scope has been granted under 37 CFR 5.13 or 5.14.

This license is to be retained by the licensee and may be used at any time on or after the effective date thereof

unless it is revoked. This license is automatically transferred to any related applications(s) filed under 37 CFR 1.53(d). This license is not retroactive.

The grant of a license does not in any way lessen the responsibility of a licensee for the security of the subject matter as imposed by any Government contract or the provisions of existing laws relating to espionage and the national security or the export of technical data. Licensees should apprise themselves of current regulations especially with respect to certain countries, of other agencies, particularly the Office of Defense Trade Controls, Department of State (with respect to Arms, Munitions and Implements of War (22 CFR 121-128)); the Bureau of Industry and Security, Department of Commerce (15 CFR parts 730-774); the Office of Foreign Assets Control, Department of Treasury (31 CFR Parts 500+) and the Department of Energy.

**NOT GRANTED**

No license under 35 U.S.C. 184 has been granted at this time, if the phrase "IF REQUIRED, FOREIGN FILING LICENSE GRANTED" DOES NOT appear on this form. Applicant may still petition for a license under 37 CFR 5.12, if a license is desired before the expiration of 6 months from the filing date of the application. If 6 months has lapsed from the filing date of this application and the licensee has not received any indication of a secrecy order under 35 U.S.C. 181, the licensee may foreign file the application pursuant to 37 CFR 5.15(b).

Client/Matter No. \_\_\_\_\_  
Sent to Calendar 11/17/05



UNITED STATES PATENT AND TRADEMARK OFFICE

UNITED STATES DEPARTMENT OF COMMERCE  
United States Patent and Trademark Office  
Address: COMMISSIONER FOR PATENTS  
P.O. Box 1450  
Alexandria, Virginia 22313-1450  
www.uspto.gov

APPLICATION NO.	FILING DATE	FIRST NAMED INVENTOR	ATTORNEY DOCKET NO.	CONFIRMATION NO.
10/648,012	08/26/2003	C. Earl Woolfork	73785-013	3337

7590 12/30/2005

ATTN: Daphne L. Burton  
McDERMOTT, WILL & EMERY, LLP  
34th Floor  
2049 Century Park East  
Los Angeles, CA 90067

EXAMINER

GRAHAM, ANDREW R

ART UNIT PAPER NUMBER

2644

DATE MAILED: 12/30/2005

Please find below and/or attached an Office communication concerning this application or proceeding.

<b>Office Action Summary</b>	<b>Application No.</b> 10/648,012	<b>Applicant(s)</b> WOOLFORK, C. EARL	
	<b>Examiner</b> Andrew Graham	<b>Art Unit</b> 2644	

-- The MAILING DATE of this communication appears on the cover sheet with the correspondence address --  
**Period for Reply**

A SHORTENED STATUTORY PERIOD FOR REPLY IS SET TO EXPIRE 3 MONTH(S) OR THIRTY (30) DAYS, WHICHEVER IS LONGER, FROM THE MAILING DATE OF THIS COMMUNICATION.

- Extensions of time may be available under the provisions of 37 CFR 1.136(a). In no event, however, may a reply be timely filed after SIX (6) MONTHS from the mailing date of this communication.
- If NO period for reply is specified above, the maximum statutory period will apply and will expire SIX (6) MONTHS from the mailing date of this communication.
- Failure to reply within the set or extended period for reply will, by statute, cause the application to become ABANDONED (35 U.S.C. § 133). Any reply received by the Office later than three months after the mailing date of this communication, even if timely filed, may reduce any earned patent term adjustment. See 37 CFR 1.704(b).

**Status**

- 1)  Responsive to communication(s) filed on 01 July 2005.
- 2a)  This action is **FINAL**.                      2b)  This action is non-final.
- 3)  Since this application is in condition for allowance except for formal matters, prosecution as to the merits is closed in accordance with the practice under *Ex parte Quayle*, 1935 C.D. 11, 453 O.G. 213.

**Disposition of Claims**

- 4)  Claim(s) 1, 4, 6 and 7 is/are pending in the application.
  - 4a) Of the above claim(s) \_\_\_\_\_ is/are withdrawn from consideration.
- 5)  Claim(s) \_\_\_\_\_ is/are allowed.
- 6)  Claim(s) 1, 4, 6 and 7 is/are rejected.
- 7)  Claim(s) \_\_\_\_\_ is/are objected to.
- 8)  Claim(s) \_\_\_\_\_ are subject to restriction and/or election requirement.

**Application Papers**

- 9)  The specification is objected to by the Examiner.
- 10)  The drawing(s) filed on 01 July 2005 is/are: a)  accepted or b)  objected to by the Examiner.  
 Applicant may not request that any objection to the drawing(s) be held in abeyance. See 37 CFR 1.85(a).  
 Replacement drawing sheet(s) including the correction is required if the drawing(s) is objected to. See 37 CFR 1.121(d).
- 11)  The oath or declaration is objected to by the Examiner. Note the attached Office Action or form PTO-152.

**Priority under 35 U.S.C. § 119**

- 12)  Acknowledgment is made of a claim for foreign priority under 35 U.S.C. § 119(a)-(d) or (f).
    - a)  All    b)  Some \*    c)  None of:
    - 1.  Certified copies of the priority documents have been received.
    - 2.  Certified copies of the priority documents have been received in Application No. \_\_\_\_\_.
    - 3.  Copies of the certified copies of the priority documents have been received in this National Stage application from the International Bureau (PCT Rule 17.2(a)).
- \* See the attached detailed Office action for a list of the certified copies not received.

**Attachment(s)**

- 1)  Notice of References Cited (PTO-892)
- 2)  Notice of Draftsperson's Patent Drawing Review (PTO-948)
- 3)  Information Disclosure Statement(s) (PTO-1449 or PTO/SB/08)  
 Paper No(s)/Mail Date \_\_\_\_\_.
- 4)  Interview Summary (PTO-413)  
 Paper No(s)/Mail Date. \_\_\_\_\_.
- 5)  Notice of Informal Patent Application (PTO-152)
- 6)  Other: \_\_\_\_\_.

**DETAILED ACTION**

***Response to Remarks/Amendment***

1. Applicant's arguments with respect to claims 1,4,6, and 7 have been considered but are moot in view of the new ground(s) of rejection.

***Specification***

2. The specification, as filed 7/1/05, is objected to under 35 U.S.C. 132 because it introduces new matter into the disclosure. 35 U.S.C. 132 states that no amendment shall introduce new matter into the disclosure of the invention. Recitations of new matter, are required to be cancelled from the amended version of the disclosure, as follows:

- page 6, line 11 "that may be as low as approximately 1.0 Mbps" conveys a throughput rate that is lower than supported by either the parent or the present application. This line incorporated new matter as of its introduction by way of the preliminary amendment of 10/25/05, even though the explicit objection thereto is newly raised herein. The applicant's remarks in regards to this aspect of the application, in pages 16 and 17 of the response, are acknowledged, but are not persuasive, at least because neither the parent case or the present application supports the 128 kHz sampling frequency of Equation 5. Further, the specification of the present

Art Unit: 2644

application does not mention a 4-bit ADC, as relied upon in the applicant's remarks.

### *Drawings*

3. New corrected drawings in compliance with 37 CFR 1.121(d) are required in this application because Figures 2 and 3 incorporate new matter, which is prohibited by 37 CFR 1.121(f). The drawings of the parent application disclose the nature of the low pass filtering being "after" the D/A converter in order to correct for out of band noise caused by the D/A converter (page 3, lines 17-20). Figure 2 of the parent case shows the filter 34 between the ADC 32 and the encoder 36, which differs from the order shown in Figure 2 of the present application. New matter is incorporated by this altered shown order, as well as the inference from the drawings that a signal containing error can be effectively low pass filtered after the erroneous part of the signal has been both encoded and channel encoded. A similar basis exists for the objection to Figure 3. The bandpass filter 54 is shown and described in the parent case as following the antenna 52 and the spread spectrum demodulator (62) (page 4, lines 6-25 of the parent application). New matter is incorporated by this drawing by virtue of its altered shown order, which suggests the bandpass filtering of a spread spectrum and digitally demodulated signals, which is not clearly supported by the present or parent application.

*Claim Rejections - 35 USC § 112*

4. Examiner's note is made of the terminology "in communication with" in the claim language of Claims 1, 4, 6, and 7. The rejections that follow have interpreted this phrase to mean "involved in an exchange of information", which serves as the broadest reasonable interpretation in light of the specification. Such a definition does not exclude the existence or presence of intervening components, as such intervening components would yet throughput information, permitting the exchange of information between other components at the input and output connections of such intervening components. To associate a more narrow interpretation, such as the "exchange of information through direct electrical interconnection" would necessitate a new matter rejection under 35 U.S.C. 112, 1<sup>st</sup> paragraph, on grounds similar to that applied above in regards to the drawings.

*Claim Rejections - 35 USC § 112 - 1<sup>st</sup> paragraph*

The following is a quotation of the first paragraph of 35 U.S.C. 112:

The specification shall contain a written description of the invention, and of the manner and process of making and using it, in such full, clear, concise, and exact terms as to enable any person skilled in the art to which it pertains, or with which it is most nearly connected, to make and use the same and shall set forth the best mode contemplated by the inventor of carrying out his invention.

4. **Claims 1 and 6** are rejected under 35 U.S.C. 112, first paragraph, as failing to comply with the written description requirement. The claim(s) contains subject matter which was not

Art Unit: 2644

described in the specification in such a way as to reasonably convey to one skilled in the relevant art that the inventor(s), at the time the application was filed, had possession of the claimed invention. The grounds upon which the following limitations are considered to involve new matter is discussed in further detail above, in regards to the corresponding matter found in the specification.

**Claims 1** contains the following limitations which incorporate new matter:

"an ADC in communication with an encoder at a signal rate of less than approximately 1.0 Mbps"; neither the present application or the parent application support this rate of throughput between the ADC and the encoder. AS detailed above with regards to the specification, this concept is also considered new matter as it is presently written into the specification.

**Claim 6** is rejected for reciting the same limitation in the seventh and eighth lines of the claim.

***Claim Rejections - 35 USC § 103***

The text of those sections of Title 35, U.S. Code not included in this action can be found in a prior Office action.

5. **Claims 1, 4, 6, and 7** is rejected under U.S.C. 103(a) as being unpatentable over Altstatt (USPN 5771441) in view of Schotz et al (USPN 5946343) and Schotz (USPN 5491839).



Art Unit: 2644

Altstatt teaches an audio dongle for an portable audio device that utilizes a RF connection to interface a pair of wireless headphones.

Specifically regarding Claim 1, Altstatt teaches:

A wireless audio music system (Figure 1) for communication of an audio music signal (from 10) from the analog headphone jack (12) connected to a battery powered transmitter (14) and received by a battery powered headphone receiver (col. 4, lines 29-53; battery for transmitter 43, col. 6, line 54; battery for headphone receiver is implicit in the wireless nature of the headphones and context of Altstatt) comprising:

an analog headphone jack (12) from an audio music source (10) in communication with a battery powered digital transmitter (14) (col. 4, lines 29-39),

The headphone system of Altstatt includes an antenna 24, receiver 22, and earphones 26 and 28.

However, the system of Altstatt is an analog transmission system that, in operation, lacks the benefits of a digitally encoded and transmitted audio signal.

With regard to the limitations of Claim 1, Altstatt does not clearly teach or suggest:

- A wireless digital audio music system for spread spectrum communication

- said battery powered digital transmitter converts an analog audio music signal from said existing analog headphone jack to a

Art Unit: 2644

digital signal using an ADC in communication with an encoder at a signal rate of less than approximately 1.0 Mbps

- said encoder in communication with a channel encoder
- said digital modulator in communication with a spread spectrum communication modulator that utilizes a code generator to create user code;
- said spread spectrum communication modulator in communication with a transmit antenna that transmits at a radio frequency of approximately 2.4 GHz for receipt by a receiving antenna;
- said receiving antenna in communication with a spread spectrum communication demodulator
- said spread spectrum communication demodulator in communication with a receiver code generator and with a digital demodulator;
- said digital demodulator in communication with a wide bandpass filter;
- said wide bandpass filter in communication with a channel decoder;
- said channel decoder in communication with a receiver decoder;
- said receiver decoder in communication with a DAC;
- said DAC in communication with a filter to pass the analog music signal in the approximate frequency band of 20Hz to 20 kHz; and
- said filter passing analog music signal will be amplified for processing to a speaker headphone set to provide high quality music for listening by a single user wearing the headphones.

Art Unit: 2644

Schotz et al discloses a wireless digital audio transmission system.

Specifically regarding Claim 1, Schotz et al, when considered in view of the teachings of Altstatt applied above, teaches or at least suggests:

- A wireless digital audio music system for spread spectrum communication (Figure 1 of Schotz et al in view of Figure 1 of Altstatt, col. 6, lines 6-54; col. 14, lines 5-12)

- said digital transmitter (22 of Schotz et al in view of 14 of Altstatt) converts an analog audio music signal from said existing analog headphone jack (analog input 30A,30B of Schotz et al in view of analog connection 12,18 of Altstatt) to a digital signal using an ADC (52) in communication with an encoder (300) at a signal rate of less than approximately 1.0 Mbps (col. 7, lines 6-15; col. 14, lines 43-58, noting that the ADC described in Schotz et al may run at lower sampling frequencies, which at least suggests the 'less than approximately 1.0 MBps', see for example, note 3 on page 11 of the included Product Spec for the Phillips SAA7360; again, as noted above 'in communication' has been interpreted herein to mean passing a signal between the two components, regardless of other components that may be disposed between two said components)

- said encoder (300) in communication with a channel encoder (98) (col. 9, lines 1-48; col. 14, lines 61-65)

- said digital modulator (102) in communication with a spread spectrum communication modulator (104) that utilizes a code generator

Art Unit: 2644

(106,308) to create user code (102 modulates input signal to produce I,Q signals, col. 10, lines 17-24; spread spectrum, col. 14, lines 5-12, col. 15, lines 40-52; code generator and user code corresponds to either house select code or PN code, col. 10, lines 43-47 or col. 15, lines 40-52; either can be considered to generate 'user codes' in context of Schotz et al and particularly Altstatt in that the use of a transmitter corresponds to a particular user operating said transmitter);

- said spread spectrum communication modulator (104) in communication (via 108) with a transmit antenna (38) that transmits at a radio frequency of approximately 2.4 GHz for receipt by a receiving antenna (40) (col. 6, lines 39-42; col. 10, lines 31-37)

- said receiving antenna (40) in communication with a spread spectrum communication demodulator (comprising 144,146,148; col. 11, line 13 - col. 12, line 24; col. 15, lines 45-52)

- said spread spectrum communication demodulator (144,146,148) in communication with a receiver code generator (408 or house code generator, col. 11, lines 13-56; col. 15, lines 45-52) and with a digital demodulator (202) (202 reverses phase shift modulation and combines signals, col. 12, lines 41-47);

- said digital demodulator (202) in communication with a wide bandpass filter (such as 138 or 142 or 178, via components of 140,146) (col. 11, lines 14-24, col. 12, lines 1-11, noting that audio signals require wideband transmission col. 2, lines 58-60, which infers such a wideband nature on these filters);

- said wide bandpass filter (such as 138 or 142 or 178) in communication (via components of 140,146) with a channel decoder (198)(col. 12, lines 1-28);
- said channel decoder (198) in communication with a receiver decoder (400)(col. 15, lines 10-18);
- said receiver decoder (400)in communication with a DAC (216)(col. 15, lines 10-26);
- said DAC (216) in communication with a filter (218A,218B) to pass the analog music signal in the approximate frequency band of 20Hz to 20 kHz (signal is music, col. 2, lines 55-58; filtering col. 13, lines 57-67)

To one of ordinary skill in the art at the time the invention was made, it would have been obvious to modify the wireless audio system of Altstatt to incorporate the digital transmission and reception scheme of Schotz et al for the wireless communication of full range audio data. The motivation behind such a modification would have been that such a digital transmission would have provided a number of benefits, including the reception of CD-quality sound and forwarding error correction, the latter of which would have enabled the system to account for errors in transmission. The digital-based system of Schotz et al would have also enabled the option of muting the output signal in the presence of sufficient levels of error. The spread spectrum technique of Schotz et al would have also limited interference from another signal to cause error in only one portion of the transmitted signal rather than the entire signal. Further, the

Art Unit: 2644

transmission components of Schotz et al would have also permitted transmission over unlicensed frequency bands.

While the system of Altstatt in view of Schotz et al discloses a variety of filtering and other signal modifications, Altstatt in view of Schotz et al is not considered to clearly teach or suggest:

- said channel encoder in communication with a digital low pass filter

- said digital low pass filter in communication with a digital modulator

- said DAC in communication with a filter that is a low pass filter

- said filter passing analog music signal will be amplified for processing to a speaker headphone set to provide high quality music for listening by a single user wearing the headphones.

However, Schotz et al incorporates another digital wireless system by reference, issued to Schotz.

Specifically regarding the limitations of Claim 1, Schotz, in view of the teachings of Altstatt and Schotz et al as applied above, teaches or at least suggests:

- said channel encoder (300 of Schotz et al) in communication with a digital low pass filter (60 of Schotz) (col. 6, lines 41-53 of Schotz for lowpass filtering buffer 60, in view of modification listed below)

Art Unit: 2644

- said digital low pass filter (60) in communication with a digital modulator (102 of Schotz et al)(col. 6, lines 41-53 of Schotz for lowpass filtering buffer 60, in view of modification listed below)

- said DAC (216 of Schotz et al, which provides output signal) in communication with a filter that is a low pass filter (152 of Schotz in view of 218A,B of Schotz et al)

- said filter (152) passing analog music signal will be amplified (by 156) for processing to a speaker headphone set (Figure 1 of Schotz, in view of headphones of Altstatt) to provide high quality music for listening by a single user wearing the headphones (col. 4, lines 2-5; col. 10, lines 19-22, noting that signal expansion is one form of amplitude control; it is further noted that otherwise output amplifying an audio signal for application to speakers is substantially well-known in the art).

To one of ordinary skill in the art at the time the invention was made, it would have been obvious to incorporate the low-pass filtering buffer of Schotz as part of the circuitry processing the output signal of the ADC (that is, as part of the signal path following the ADC) in the transmitter of Altstatt in view of Schotz et al. The motivation behind such a modification would have been that such a filtering buffer would have removed high frequency harmonics resulting from the multiplexing of the signal in the ADC. To one of ordinary skill in the art at the time the invention was made, it would have been obvious to incorporate low pass filtering as taught by Schotz for the output filters of Altstatt in view of Schotz et al. The motivation behind

Art Unit: 2644

such a modification would have been that such low pass filtering would have enabled the removal of any pilot or multiplexing byproducts yet present in the output signal. To one of ordinary skill in the art at the time the invention was made, it would have been obvious to incorporate the compression and expansion circuitry of Schotz as part of the input and output handling circuitry of the system of Altstatt in view of Schotz et al. The motivation behind such a modification would have been that such a form of signal amplitude control would have placed the throughput audio signals within the linear operating ranges of the audio channels in the transmitter and receiver.

Regarding Claim 4, please refer above to the functions corresponding to the components cited above in the rejection of the similar limitations of Claim 1. The citations provided therein form the basis for the rejection of the similar limitations of the method steps of Claim 4. In addition, the claimed power level and distance of approximately 10 ft is at least considered suggested by Schotz et al.'s reference to a range within 10 ft (col. 5, lines 26-36).

Regarding Claim 6, please refer above to the components cited above in the rejection of the similar limitations of Claim 1, particularly the first portion of Claim 1. The citations provided therein form the basis for the rejection of the similar limitations of the apparatus of Claim 6.

Regarding Claim 7, please refer above to the components cited above in the rejection of the similar limitations of Claim 1, particularly the first portion of Claim 1. The citations provided



Art Unit: 2644

therein form the basis for the rejection of the similar limitations of the apparatus of Claim 7.

**Conclusion**

Applicant's amendment necessitated the new ground(s) of rejection presented in this Office action. Accordingly, **THIS ACTION IS MADE FINAL**. See MPEP § 706.07(a). Applicant is reminded of the extension of time policy as set forth in 37 CFR 1.136(a).

A shortened statutory period for reply to this final action is set to expire THREE MONTHS from the mailing date of this action. In the event a first reply is filed within TWO MONTHS of the mailing date of this final action and the advisory action is not mailed until after the end of the THREE-MONTH shortened statutory period, then the shortened statutory period will expire on the date the advisory action is mailed, and any extension fee pursuant to 37 CFR 1.136(a) will be calculated from the mailing date of the advisory action. In no event, however, will the statutory period for reply expire later than SIX MONTHS from the date of this final action.

Any inquiry concerning this communication or earlier communications from the examiner should be directed to Andrew Graham whose telephone number is 571-272-7517. The examiner can normally be reached on Monday-Friday, 8:30 AM to 5:00 PM (EST).

If attempts to reach the examiner by telephone are unsuccessful, the examiner's supervisor, Vivian Chin can be reached on 571-272-7848.

Application/Control Number: 10/648,012

Page 15

Art Unit: 2644

The fax phone number for the organization where this application or proceeding is assigned is 571-273-8300.

Information regarding the status of an application may be obtained from the Patent Application Information Retrieval (PAIR) system. Status information for published applications may be obtained from either Private PAIR or Public PAIR. Status information for unpublished applications is available through Private PAIR only. For more information about the PAIR system, see <http://pair-direct.uspto.gov>. Should you have questions on access to the Private PAIR system, contact the Electronic Business Center (EBC) at 866-217-9197 (toll-free).

  
ag

  
HUYEN LE  
PRIMARY EXAMINER

<b>Notice of References Cited</b>	Application/Control No. 10/648,012	Applicant(s)/Patent Under Reexamination WOOLFORK, C. EARL	
	Examiner Andrew Graham	Art Unit 2644	Page 1 of 1

**U.S. PATENT DOCUMENTS**

*	Document Number Country Code-Number-Kind Code	Date MM-YYYY	Name	Classification
*	A US-5,946,343 A	08-1999	Schotz et al.	375/141
*	B US-5,491,839 A	02-1996	Schotz, Larry	381/79
*	C US-5,771,441 A	06-1998	Altstatt, John E.	455/66.1
	D US-			
	E US-			
	F US-			
	G US-			
	H US-			
	I US-			
	J US-			
	K US-			
	L US-			
	M US-			

**FOREIGN PATENT DOCUMENTS**

*	Document Number Country Code-Number-Kind Code	Date MM-YYYY	Country	Name	Classification
	N				
	O				
	P				
	Q				
	R				
	S				
	T				

**NON-PATENT DOCUMENTS**

*	Include as applicable: Author, Title Date, Publisher, Edition or Volume, Pertinent Pages)
U	SAA7360 Bitstream conversion ADC for digital audio systems. Datasheet [online]. Philips Semiconductors, 1995 [retrieved on 2005-12-15]. Retrieved from the Internet: <URL: <a href="http://www.ortodoxism.ro/datasheets/philips/SAA7360GP.pdf">http://www.ortodoxism.ro/datasheets/philips/SAA7360GP.pdf</a> >
V	
W	
X	

\*A copy of this reference is not being furnished with this Office action. (See MPEP § 707.05(a).)  
Dates in MM-YYYY format are publication dates. Classifications may be US or foreign.

**Index of Claims**



Application/Control No.

10/648,012

Examiner

Andrew Graham

Applicant(s)/Patent under Reexamination

WOOLFORK, C. EARL

Art Unit

2644

√	Rejected
=	Allowed

-	(Through numeral) Cancelled
+	Restricted

N	Non-Elected
I	Interference

A	Appeal
O	Objected

Claim		Date			
Final	Original	5/10/05	12/22/05		
1	√	√			
2	√				
3	√				
4	√	√			
5	√				
6		√			
7		√			
8					
9					
10					
11					
12					
13					
14					
15					
16					
17					
18					
19					
20					
21					
22					
23					
24					
25					
26					
27					
28					
29					
30					
31					
32					
33					
34					
35					
36					
37					
38					
39					
40					
41					
42					
43					
44					
45					
46					
47					
48					
49					
50					

Claim		Date			
Final	Original				
51					
52					
53					
54					
55					
56					
57					
58					
59					
60					
61					
62					
63					
64					
65					
66					
67					
68					
69					
70					
71					
72					
73					
74					
75					
76					
77					
78					
79					
80					
81					
82					
83					
84					
85					
86					
87					
88					
89					
90					
91					
92					
93					
94					
95					
96					
97					
98					
99					
100					

Claim		Date			
Final	Original				
101					
102					
103					
104					
105					
106					
107					
108					
109					
110					
111					
112					
113					
114					
115					
116					
117					
118					
119					
120					
121					
122					
123					
124					
125					
126					
127					
128					
129					
130					
131					
132					
133					
134					
135					
136					
137					
138					
139					
140					
141					
142					
143					
144					
145					
146					
147					
148					
149					
150					

**Search Notes**



Application/Control No.

10/648,012

Examiner

Andrew Graham

Applicant(s)/Patent under Reexamination

WOOLFORK, C. EARL

Art Unit

2644

**SEARCHED**

Class	Subclass	Date	Examiner
700	94	5/10/2005	AG
714	709,780	5/10/2005	AG
706	8,9	5/10/2005	AG
455	3.06,41	5/10/2005	AG
455	66.1	5/10/2005	AG
375	224	5/10/2005	AG
381	79	12/15/2005	AG
455	41.3	12/15/2005	AG

**INTERFERENCE SEARCHED**

Class	Subclass	Date	Examiner

**SEARCH NOTES  
(INCLUDING SEARCH STRATEGY)**

	DATE	EXMR
EAST search using USPAT PGPUB DERWENT EPO JPO USOCR dbs	5/10/2005	AG
cls/sbcls at left w/ keywords Bluetooth, fuzzy, soft decision, bit energy, probability, membership, and equivalents	5/10/2005	AG
Parent application, including applied references, considered	5/10/2005	AG
Inventor search, using EAST and Internet search engine	5/10/2005	AG
381/2,455/41.2,41.3(t.o.w/low pass) 381/270(t.o.w/ headphone) various text search - see search history printout	12/15/2005	AG

Ref #	Hits	Search Query	DBs	Default Operator	Plurals	Time Stamp
S126	9	"lindemann, eric".in. and "381"/\$.ccls.	US-PGPUB; USPAT; USOCR; EPO; JPO; DERWENT	OR	ON	2005/12/15 14:33
S127	1	spread adj spectrum with headphone	US-PGPUB; USPAT; USOCR; EPO; JPO; DERWENT	OR	ON	2005/12/15 14:35
S128	583	380/270.ccls.	US-PGPUB; USPAT; USOCR; EPO; JPO; DERWENT	OR	ON	2005/12/15 15:30
S129	54406	earphon\$3 headphon\$3 (ear head) adj (phon\$3 set) headset earset	US-PGPUB; USPAT; USOCR; EPO; JPO; DERWENT	OR	ON	2005/12/15 14:36
S130	28	S128 and S129	US-PGPUB; USPAT; USOCR; EPO; JPO; DERWENT	OR	ON	2005/12/15 14:36
S131	95	455/41.3.ccls.	US-PGPUB; USPAT; USOCR; EPO; JPO; DERWENT	OR	ON	2005/12/15 16:06
S132	6	"5946343".pn. "4845751".pn. "6278751".pn.	US-PGPUB; USPAT; USOCR; EPO; JPO; DERWENT	OR	ON	2005/12/16 07:56
S133	58	digital adj (anti adj alias\$3 antialias\$3)	US-PGPUB; USPAT; USOCR; EPO; JPO; DERWENT	OR	ON	2005/12/22 16:25
S134	2833	digital adj (lowpass low adj pass lpf)	US-PGPUB; USPAT; USOCR; EPO; JPO; DERWENT	OR	ON	2005/12/22 16:27

S13 5	86	digital adj (lowpass low adj pass lpf) and "381"/\$.ccls.	US-PGPUB; USPAT; USOCR; EPO; JPO; DERWENT	OR	ON	2005/12/22 16:27
S13 6	39	("2236946"   "2828413"   "2840694"   "3080785"   "3085460"   "3087117"   "3296916"   "3579211"   "3743751"   "3781451"   "3825666"   "3863157"   "3901118"   "3906160"   "4004228"   "4229826"   "4335930"   "4344184"   "4369521"   "4430757"   "4453269"   "4464792"   "4471493"   "4612688"   "4647135"   "4721926"   "4794622"   "4845751"   "4899388"   "4988957"   "5025704"   "5214568").PN.	US-PGPUB; USPAT; USOCR	OR	ON	2005/12/22 16:58
S13 7	17	("5771441").URPN.	USPAT	OR	ON	2005/12/22 17:05
S13 8	8	("4335281"   "4682363"   "4893344"   "5412736"   "5537667"   "5610988"   "5771441"   "5835610").PN.	US-PGPUB; USPAT; USOCR	OR	ON	2005/12/22 17:14
S13 9	0	455/41.3.ccls. and (lowpass low adj pass lpf)	US-PGPUB; USPAT; USOCR	OR	ON	2005/12/22 17:14
S14 0	0	455/41.3.ccls. and (lowpass low adj pass lpf)	US-PGPUB; USPAT; USOCR; EPO; JPO; DERWENT; IBM_TDB	OR	ON	2005/12/22 17:15
S14 1	39	455/41.2.ccls. and (lowpass low adj pass lpf)	US-PGPUB; USPAT; USOCR; EPO; JPO; DERWENT; IBM_TDB	OR	ON	2005/12/22 17:28
S14 2	1264476	(analog adj digital AD "a" adj "d")(lowpass low adj pass lpf)	US-PGPUB; USPAT; USOCR; EPO; JPO; DERWENT; IBM_TDB	OR	ON	2005/12/22 17:17

S14 3	16220	(analog adj digital AD "a" adj "d")same(lowpass low adj pass lpf)	US-PGPUB; USPAT; USOCR; EPO; JPO; DERWENT; IBM_TDB	OR	ON	2005/12/22 17:17
S14 4	8583	(analog adj digital AD "a" adj "d") with (lowpass low adj pass lpf)	US-PGPUB; USPAT; USOCR; EPO; JPO; DERWENT; IBM_TDB	OR	ON	2005/12/22 17:18
S14 5	2081	(analog adj digital AD "a" adj "d") with (lowpass low adj pass lpf) and radio	US-PGPUB; USPAT; USOCR; EPO; JPO; DERWENT; IBM_TDB	OR	ON	2005/12/22 17:18
S14 6	2656	(analog adj digital AD "a" adj "d") with (lowpass low adj pass lpf) and (RF radio)	US-PGPUB; USPAT; USOCR; EPO; JPO; DERWENT; IBM_TDB	OR	ON	2005/12/22 17:18
S14 7	2656	(analog adj digital AD "a" adj "d") with (lowpass low adj pass lpf) and (RF radio)	US-PGPUB; USPAT; USOCR; EPO; JPO; DERWENT; IBM_TDB	OR	ON	2005/12/22 17:20
S14 8	441	(analog adj digital AD "a" adj "d") with (lowpass low adj pass lpf) and "341"/\$.ccls.	US-PGPUB; USPAT; USOCR; EPO; JPO; DERWENT; IBM_TDB	OR	ON	2005/12/22 17:21
S14 9	185	(analog adj digital AD "a" adj "d") with (lowpass low adj pass lpf) and "381"/\$.ccls.	US-PGPUB; USPAT; USOCR; EPO; JPO; DERWENT; IBM_TDB	OR	ON	2005/12/22 17:21
S15 0	52	(analog adj digital AD "a" adj "d") with (lowpass low adj pass lpf) and "381"/\$.ccls. and (rf radio)	US-PGPUB; USPAT; USOCR; EPO; JPO; DERWENT; IBM_TDB	OR	ON	2005/12/22 17:21



S15 1	104	381/2.ccls. and (lowpass low adj pass lpf)	US-PGPUB; USPAT; USOCR; EPO; JPO; DERWENT; IBM_TDB	OR	ON	2005/12/22 17:28
S15 2	34	381/2.ccls. and (lowpass low adj pass lpf) and (AD "a" adj D analog adj digital)	US-PGPUB; USPAT; USOCR; EPO; JPO; DERWENT; IBM_TDB	OR	ON	2005/12/22 17:29
S15 3	17	("5771441").URPN.	USPAT	OR	ON	2005/12/22 17:45
S15 4	20	("3087117"   "3906160"   "4232189"   "4369521"   "4845751"   "5167535"   "5289543"   "5303398"   "5333176"   "5423056"   "5590407"   "5628055"   "5721783"   "5771441"   "6064860"   "6208867"   "6212282"   "6353406"   "6452626").PN.	US-PGPUB; USPAT; USOCR	OR	ON	2005/12/22 17:48
S15 5	34	("4845751").URPN.	USPAT	OR	ON	2005/12/22 17:51
S15 6	17	("5247293").URPN.	USPAT	OR	ON	2005/12/22 18:01
S15 7	1710	S134	USPAT	OR	ON	2005/12/22 18:01
S15 8	80	381/79.ccls.	USPAT	OR	ON	2005/12/22 18:01
S15 9	17	("5771441").URPN.	USPAT	OR	ON	2005/12/23 13:30
S16 0	1	"5946343".pn.	USPAT	OR	ON	2005/12/23 13:30



UNITED STATES PATENT AND TRADEMARK OFFICE

*rw*

UNITED STATES DEPARTMENT OF COMMERCE  
United States Patent and Trademark Office  
Address: COMMISSIONER FOR PATENTS  
P.O. Box 1450  
Alexandria, Virginia 22313-1450  
www.uspto.gov

APPLICATION NO.	FILING DATE	FIRST NAMED INVENTOR	ATTORNEY DOCKET NO.	CONFIRMATION NO.
10/648,012	08/26/2003	C. Earl Woolfork	73785-013	3337

7590                      02/09/2006  
 ATTN: Daphne L. Burton  
 McDERMOTT, WILL & EMERY, LLP  
 34th Floor  
 2049 Century Park East  
 Los Angeles, CA 90067

EXAMINER

GRAHAM, ANDREW R

ART UNIT	PAPER NUMBER
2644	

2644

DATE MAILED: 02/09/2006

Please find below and/or attached an Office communication concerning this application or proceeding.

<b>Interview Summary</b>	<b>Application No.</b> 10/648,012	<b>Applicant(s)</b> WOOLFORK, C. EARL	
	<b>Examiner</b> Andrew Graham	<b>Art Unit</b> 2644	

All participants (applicant, applicant's representative, PTO personnel):

- (1) A. Graham. (3) D. Burton.  
(2) X. Mei. (4) E. Woolfork.

Date of Interview: \_\_\_\_\_.

Type: a)  Telephonic b)  Video Conference  
c)  Personal [copy given to: 1)  applicant 2)  applicant's representative]

Exhibit shown or demonstration conducted: d)  Yes e)  No.  
If Yes, brief description: \_\_\_\_\_.

Claim(s) discussed: 1.

Identification of prior art discussed: Altstatt, Schotz.

Agreement with respect to the claims f)  was reached. g)  was not reached. h)  N/A.

Substance of Interview including description of the general nature of what was agreed to if an agreement was reached, or any other comments: See Continuation Sheet.

(A fuller description, if necessary, and a copy of the amendments which the examiner agreed would render the claims allowable, if available, must be attached. Also, where no copy of the amendments that would render the claims allowable is available, a summary thereof must be attached.)

THE FORMAL WRITTEN REPLY TO THE LAST OFFICE ACTION MUST INCLUDE THE SUBSTANCE OF THE INTERVIEW. (See MPEP Section 713.04). If a reply to the last Office action has already been filed, APPLICANT IS GIVEN A NON-EXTENDABLE PERIOD OF THE LONGER OF ONE MONTH OR THIRTY DAYS FROM THIS INTERVIEW DATE, OR THE MAILING DATE OF THIS INTERVIEW SUMMARY FORM, WHICHEVER IS LATER, TO FILE A STATEMENT OF THE SUBSTANCE OF THE INTERVIEW. See Summary of Record of Interview requirements on reverse side or on attached sheet.

2

  
XU MEI  
PRIMARY EXAMINER

Examiner Note: You must sign this form unless it is an Attachment to a signed Office action.

  
\_\_\_\_\_  
Examiner's signature, if required

## Summary of Record of Interview Requirements

### Manual of Patent Examining Procedure (MPEP), Section 713.04, Substance of Interview Must be Made of Record

A complete written statement as to the substance of any face-to-face, video conference, or telephone interview with regard to an application must be made of record in the application whether or not an agreement with the examiner was reached at the interview.

### Title 37 Code of Federal Regulations (CFR) § 1.133 Interviews Paragraph (b)

In every instance where reconsideration is requested in view of an interview with an examiner, a complete written statement of the reasons presented at the interview as warranting favorable action must be filed by the applicant. An interview does not remove the necessity for reply to Office action as specified in §§ 1.111, 1.135. (35 U.S.C. 132)

### 37 CFR §1.2 Business to be transacted in writing.

All business with the Patent or Trademark Office should be transacted in writing. The personal attendance of applicants or their attorneys or agents at the Patent and Trademark Office is unnecessary. The action of the Patent and Trademark Office will be based exclusively on the written record in the Office. No attention will be paid to any alleged oral promise, stipulation, or understanding in relation to which there is disagreement or doubt.

The action of the Patent and Trademark Office cannot be based exclusively on the written record in the Office if that record is itself incomplete through the failure to record the substance of interviews.

It is the responsibility of the applicant or the attorney or agent to make the substance of an interview of record in the application file, unless the examiner indicates he or she will do so. It is the examiner's responsibility to see that such a record is made and to correct material inaccuracies which bear directly on the question of patentability.

Examiners must complete an Interview Summary Form for each interview held where a matter of substance has been discussed during the interview by checking the appropriate boxes and filling in the blanks. Discussions regarding only procedural matters, directed solely to restriction requirements for which interview recordation is otherwise provided for in Section 812.01 of the Manual of Patent Examining Procedure, or pointing out typographical errors or unreadable script in Office actions or the like, are excluded from the interview recordation procedures below. Where the substance of an interview is completely recorded in an Examiners Amendment, no separate Interview Summary Record is required.

The Interview Summary Form shall be given an appropriate Paper No., placed in the right hand portion of the file, and listed on the "Contents" section of the file wrapper. In a personal interview, a duplicate of the Form is given to the applicant (or attorney or agent) at the conclusion of the interview. In the case of a telephone or video-conference interview, the copy is mailed to the applicant's correspondence address either with or prior to the next official communication. If additional correspondence from the examiner is not likely before an allowance or if other circumstances dictate, the Form should be mailed promptly after the interview rather than with the next official communication.

The Form provides for recordation of the following information:

- Application Number (Series Code and Serial Number)
- Name of applicant
- Name of examiner
- Date of interview
- Type of interview (telephonic, video-conference, or personal)
- Name of participant(s) (applicant, attorney or agent, examiner, other PTO personnel, etc.)
- An indication whether or not an exhibit was shown or a demonstration conducted
- An identification of the specific prior art discussed
- An indication whether an agreement was reached and if so, a description of the general nature of the agreement (may be by attachment of a copy of amendments or claims agreed as being allowable). Note: Agreement as to allowability is tentative and does not restrict further action by the examiner to the contrary.
- The signature of the examiner who conducted the interview (if Form is not an attachment to a signed Office action)

It is desirable that the examiner orally remind the applicant of his or her obligation to record the substance of the interview of each case. It should be noted, however, that the Interview Summary Form will not normally be considered a complete and proper recordation of the interview unless it includes, or is supplemented by the applicant or the examiner to include, all of the applicable items required below concerning the substance of the interview.

A complete and proper recordation of the substance of any interview should include at least the following applicable items:

- 1) A brief description of the nature of any exhibit shown or any demonstration conducted,
- 2) an identification of the claims discussed,
- 3) an identification of the specific prior art discussed,
- 4) an identification of the principal proposed amendments of a substantive nature discussed, unless these are already described on the Interview Summary Form completed by the Examiner,
- 5) a brief identification of the general thrust of the principal arguments presented to the examiner,  
(The identification of arguments need not be lengthy or elaborate. A verbatim or highly detailed description of the arguments is not required. The identification of the arguments is sufficient if the general nature or thrust of the principal arguments made to the examiner can be understood in the context of the application file. Of course, the applicant may desire to emphasize and fully describe those arguments which he or she feels were or might be persuasive to the examiner.)
- 6) a general indication of any other pertinent matters discussed, and
- 7) if appropriate, the general results or outcome of the interview unless already described in the Interview Summary Form completed by the examiner.

Examiners are expected to carefully review the applicant's record of the substance of an interview. If the record is not complete and accurate, the examiner will give the applicant an extendable one month time period to correct the record.

### Examiner to Check for Accuracy

If the claims are allowable for other reasons of record, the examiner should send a letter setting forth the examiner's version of the statement attributed to him or her. If the record is complete and accurate, the examiner should place the indication, "Interview Record OK" on the paper recording the substance of the interview along with the date and the examiner's initials.

Continuation of Substance of Interview including description of the general nature of what was agreed to if an agreement was reached, or any other comments: Three main aspects of application were discussed; (1) Regarding new matter and 112 rejections, applicant indicated intent to cancel subject matter in question from spec, drawings, and claims; (2) Regarding "no motivation to combine" argument, applicant indicated that power consumption properties of Schotz reference would substantially reduce battery life of transducer of Altstatt, thus creating a 'rendering useless for intended operation' situation. The examiner respectfully submitted that the bodily incorporation of Schotz into Altstatt is not a part of the obviousness test for the combination, further noting that the conceptual teachings of Schotz were not restricted to the explicit, exemplary part numbers referenced therein. No agreement was reached regarding this aspect of the final rejection. (3) Applicant also presented the argument that the user code of the application varied from the 'house' code of the Schotz reference in that the former was more 'unique' or drawn from a larger pool of possible values. The examiner respectfully submitted that any such distinction was not present in the pending claim language, which states "user code". A possible amendment to further define this code in the pending claim language was discussed, though no agreement was reached regarding the language or, thus, the non-obviousness or allowability of any such amended limitation. Applicant also discussed possible amendment to the channel decoder to further specify a Viterbi decoder, though no agreement was reached with regards to amended claim language, nor was an indication given regarding the allowability of any such amendment, as further search and/or consideration may be required.

PTOL-413A (03-03)  
 Approved for use through xx/xx/xxxx. OMB 0651-0031  
 U.S. Patent and Trademark Office: U.S. DEPARTMENT OF COMMERCE

**Applicant Initiated Interview Request Form**

Application No.: 10/648,012 First Named Applicant: C. Earl Woolfork  
 Examiner: Andrew Graham Art Unit: 2644 Status of Application: Pending

Tentative Participants:  
 (1) Andrew Graham, Examiner (2) Daphne L. Burton, Applicant's Representative  
 (3) SPE (4) C. Earl Woolfork, Applicant

Proposed Date of Interview: January 26, 2006 (Thurs.) Proposed Time: 2:00 pm ET (AM/PM)

Type of Interview Requested:  
 (1)  Telephone (2)  Personal (3)  Video Conference

Exhibit To Be Shown or Demonstrated:  YES  NO  
 If yes, provide brief description: \_\_\_\_\_

**Issues To Be Discussed**

Issues (Rej., Obj., etc.)	Claims/ Fig. #s	Prior Art	Discussed	Agreed	Not Agreed
(1) <u>references do not teach or suggest all claim limitation</u>			<input type="checkbox"/>	<input type="checkbox"/>	<input checked="" type="checkbox"/>
(2) <u>there is no suggestion or motivation to modify the references</u>			<input type="checkbox"/>	<input type="checkbox"/>	<input checked="" type="checkbox"/>
(3) <u>Other Rejections</u>			<input type="checkbox"/>	<input type="checkbox"/>	<input checked="" type="checkbox"/>
(4) _____			<input type="checkbox"/>	<input type="checkbox"/>	<input type="checkbox"/>

Continuation Sheet Attached

Brief Description of Arguments to be Presented:

An interview was conducted on the above-identified application on: 1/26/05

**Note:**  
 This form should be completed by applicant and submitted to the examiner in advance of the interview (see MPEP § 713.01).  
 This application will not be delayed from issue because of applicant's failure to submit a written record of this interview. Therefore, applicant is advised to file a statement of the substance of this interview (37 CFR 1.133(b)) as soon as possible.

Daphne L. Burton  
 (Applicant/Applicant's Representative Signature)

Andrew Graham  
 (Examiner/SPE Signature)

This collection of information is required by 37CFR 1.33. The information is required to obtain and retain a benefit by the public which is to file (and by the USPTO to process) an application. Confidentiality is governed by 35 U.S.C. 122 and 37 CFR 1.14. This collection is estimated to take 21 minutes to complete, including gathering, preparing, and submitting the completed application form to the USPTO. Time will vary depending upon the individual case. Any comments on the amount time you require to complete this form and/or suggestions for reducing this burden, should be sent to the Chief Information Officer, U.S. Patent and Trademark Office, U.S. Department of Commerce, Washington, DC 20231. DO NOT SEND FEES OR COMPLETED FORMS TO THIS ADDRESS. SEND TO: Commissioner for Patents, Washington, DC 20231

If you need assistance in completing this form, call 1-800-PTO-9199 and select option 2.

LAS99 1437207-1.073785.0013

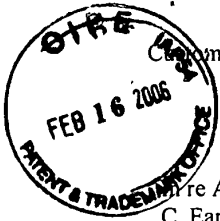

Customer No. 33401

Attorney Docket No. 73785-013

*Handwritten initials*

**IN THE UNITED STATES PATENT AND TRADEMARK OFFICE**

Re Application of:  
C. Earl Woolfork  
  
Serial No.: 10/648,012  
  
Filed: August 26, 2003  
  
For: WIRELESS DIGITAL  
AUDIO MUSIC SYSTEM

Group Art Unit: 2644  
  
Examiner: Andrew Graham

**CERTIFICATE OF MAILING (37 C.F.R. § 1.8(a))**  
  
I hereby certify that this correspondence is being deposited with the United States Postal Service as First Class Mail under 37 CFR 1.8(a) in an envelope addressed to, Commissioner for Patents, P.O. Box 1450, Alexandria, VA 22313-1450 on February 10, 2006.  
  
*Anita Chou*  
\_\_\_\_\_  
Anita Chou

Mail Stop: Amendment  
Commissioner for Patents  
P.O. Box 1450  
Alexandria, VA 22313-1450

**TRANSMITTAL AMENDMENT**

Sir:

Transmitted herewith is an Amendment in response to the Office Action dated December 30, 2005 for the above-identified application.

**The present application qualifies for Small Entity Status under 37 C.F.R. §1.27.**

The fee has been calculated as shown below:

	Claims Remaining After Amendment		Highest Number Previously Paid For		Number Extra		Standard Rate		Add'l. Fee
<b>TOTAL</b>	10	-	20	=	0	x	\$25	=	\$0
<b>INDEP.</b>	10	-	4	=	6	x	\$100	=	\$600
<b>SUBTOTAL</b>									\$600
___ month extension Fee									\$
1st Presentation of Multiple Dependent Claim									\$0
<b>TOTAL</b>									\$600

Please charge my Deposit Account No. 50-1946 the amount of \$600.00. A duplicate copy of this sheet is enclosed.

We authorize the Commissioner to charge Deposit Account No. 50-1946 for payment of any additional fees required by this response or to credit any overpayment to the account.

*February 10, 2006*  
DATE

*Daphne L. Burton*  
Daphne L. Burton  
Registration No. 45,323  
Attorney for Applicant

MCDERMOTT WILL & EMERY, LLP  
2049 Century Park East, 34th Floor  
Los Angeles, CA 90067  
Telephone: (310) 277-4110  
Facsimile: (310) 277-4730

LAS99 1439108-1.073785.0013

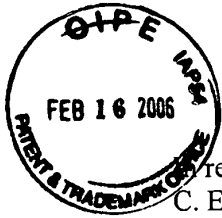

PATENT

IN THE UNITED STATES PATENT AND TRADEMARK OFFICE

Re Application of:  
C. Earl Woolfork

Group Art Unit: 2644

Examiner: Andrew Graham

Serial No.: 10/648,012

Filed: August 26, 2003

For: WIRELESS DIGITAL AUDIO  
MUSIC SYSTEM

CERTIFICATE OF MAILING (37 C.F.R. § 1.8(a))

I hereby certify that this correspondence is being deposited with the United States Postal Service as First Class Mail under 37 CFR 1.8(a) in an envelope addressed to, Mail Stop: Amendment, Commissioner for Patents, P.O. Box 1450, Alexandria, VA 22313-1450 on February 10, 2006.

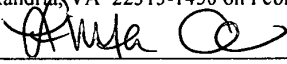
  
Anita Chou

AMENDMENT

Mail Stop Amendment  
Commissioner for Patents  
P.O. Box 1450  
Alexandria, VA 22313-1450

Sir:

In response to the Office action mailed on December 30, 2005, please amend the above-identified application as indicated below.

**Amendments to the Specification** begin on page 2 of this paper.

**Amendments to the Claims** are reflected in the listing of claims which begins on page 3 of this paper.

**Amendments to the Drawings** begin on page 12 of this paper and included is both an attached replacement sheet and an annotated sheet showing changes.

**Remarks** begin on page 13 of this paper.

02/17/2006 BABRAHA1 00000035 501946 10648012

01 FC:2201 600.00 DA

LAS99 1439267-1.073785.0013



**Amendments to the Specification:**

Please amend the specification as follows:

On page 6, line 10, (or paragraph [0009], line 12) please delete the following sentence:

"This digital signal has a throughput of approximately 1.4 Mbps that may be as low as approximately 1.0 Mbps."

On page 6, line 11, please delete the number "34" at the end of the sentence so that this sentence will read: "After digital conversion, the digital signal may be processed by a digital low pass filter."

At para. 0010, line 6, please delete the number "64" at the end of the sentence so that this sentence will read: "The transmitted signal from transmit antenna 24 may be received by receiving antenna 52 and communicated to a wideband bandpass filter (BPF)."

At paragraph [0016], line 1, please replace the first sentence with the following:

--The channel decoder 66 may be a Viterbi decoder. A channel decoder 66 may be in communication with the bandpass filter. --

At paragraph [0010], line 6, please add the following sentences at the beginning of this paragraph: --A digital signal may be received at antenna receiving antenna 52 and communicated to, e.g., a wideband bandpass filter. The received spread spectrum signal may then be communicated to a 2.4 GHz direct conversion receiver 56. A frequency shift keying (FSK) modulation/detection technique could be used given a frequency hopping spread spectrum (FHSS) system choice. The direct conversion receiver 56 may provide a means to convert the received signal while using timing and synchronization to capture the correct bit sequence embedded in the received spread spectrum signal. --

**Amendments to the Claims:**

Please amend the claims as follows:

1. (Currently amended) A wireless digital audio music system for spread spectrum communication of an audio music signal from the analog headphone jack connected to a battery powered spread spectrum transmitter and received by a battery powered spread spectrum headphone receiver comprising:

an analog headphone jack from an analog audio music source in communication with a battery powered digital transmitter;

said battery powered digital transmitter converts an analog audio music signal from said existing analog headphone jack to a digital signal using an ADC in communication with an encoder [at a signal rate of less than approximately 1.0 Mbps];

said encoder in communication with a channel encoder;

said channel encoder in communication with [a digital low pass filter;

said digital low pass filter in communication with] a digital modulator;

said digital modulator in communication with a spread spectrum communication modulator that utilizes a code generator to create [user code] a unique hop pattern for each individual user;

said spread spectrum communication modulator in communication with a transmit antenna that transmits at a radio frequency of approximately 2.4 GHz for receipt by a receiving antenna;

said receiving antenna in communication with a spread spectrum communication demodulator;

said spread spectrum communication demodulator in communication with a receiver code generator and with a digital demodulator;

said digital demodulator in communication with [a wide bandpass filter;

said wide bandpass filter in communication with] a channel decoder;

said channel decoder in communication with a receiver decoder;

said receiver decoder in communication with a DAC;

said DAC in communication with a low pass filter to pass the analog music signal in the approximate frequency band of 20 Hz to 20 kHz; and

said low pass filter passing analog music signal will be amplified for processing to a speaker headphone set to provide high quality music for listening by a single user wearing the headphones.

2. (Canceled).

3. (Canceled).

4. (Currently amended) A method for battery powered wireless communication transmission and reception of high fidelity audio music between a battery operated digital transmitter and a battery operated digital receiver headphone comprising the steps of:

connecting the plug attached to said battery operated digital transmitter to the existing analog headphone jack of an audio music source;

converting a music audio signal to a digital communication signal using an ADC in communication with an encoder;

encoding the communication signal using channel encoding;

[digital low pass filtering the communication signal;]

modulating the digital communication signal using a digital modulator;

creating a spread spectrum signal using a code generator to modulate a [unique user code] unique hop pattern for each individual user;

transmitting said spread spectrum signal at a radio frequency of approximately 2.4 GHz [at a power level for reception at a distance up to approximately 10 feet from said battery operated transmitter];

receiving said spread spectrum signal at said battery operated receiver headphones;

demodulating said spread spectrum signal;

demodulating said digital communication signal;

[bandpass filtering said digital communication signal;]

channel decoding of said digital communication signal;

converting said digital communication signal back to said analog music audio signal using a decoder in communication with a DAC; and

[communication] communicating said analog music audio signal to a headphone speaker within the headphone receiver.

5. (Canceled)

6. (Currently amended) An audio music digital wireless transmitter for spread spectrum communication of an audio music signal [from an analog headphone jack connected to a battery powered spread spectrum transmitter], comprising:

an analog headphone jack from an audio music source in communication with a battery powered digital transmitter;

said battery powered digital transmitter [converts] being configured to convert an analog audio music signal from said existing analog headphone jack to a digital signal using an ADC in communication with an encoder [at a signal rate of less than approximately 1.0 Mbps];

said encoder in communication with a channel encoder;

said channel encoder in communication with [a digital low pass filter;

said digital low pass filter in communication with] a digital modulator;

said digital modulator in communication with a spread spectrum communication modulator that utilizes a code generator to create [user code] a unique hop pattern for each individual user; and

said spread spectrum communication modulator in communication with a transmit antenna that transmits at a radio frequency of approximately 2.4 GHz for receipt by a receiving antenna.

7. (Currently amended) An audio music digital wireless receiver for spread spectrum communication of an audio music signal [to be received by a battery powered spread spectrum receiver], comprising:

a receiving antenna in communication with a spread spectrum communication demodulator;

said spread spectrum communication demodulator in communication with a code generator configured to create a unique hop pattern for each individual user;

said digital demodulator in communication with [a wide bandpass filter;

said wide bandpass filter in communication with] a channel decoder;

said channel decoder in communication with a decoder;

said decoder in communication with a DAC;

said DAC in communication with a low pass filter to pass the analog music signal in the approximate frequency band of 20 Hz to 20kHz; and

said low pass filter passing analog music signal will be amplified for processing to a speaker headphone set to provide high quality music for listening by a single user wearing the headphones.

8. (New) A wireless digital audio music system for spread spectrum communication of an audio music signal from the analog headphone jack connected to a battery powered spread spectrum transmitter and received by a battery powered spread spectrum headphone receiver comprising:

an analog headphone jack from an audio music source in communication with a battery powered digital transmitter;

said battery powered digital transmitter converts an analog audio music signal from said existing analog headphone jack to a digital signal using an ADC in communication with an encoder;

said encoder in communication with a channel encoder;

said channel encoder in communication with [a digital low pass filter;

said digital low pass filter in communication with] a digital modulator;

said digital modulator in communication with a spread spectrum communication modulator that utilizes a code generator to create a unique hop pattern for each individual user;

said spread spectrum communication modulator in communication with a transmit antenna that transmits at a radio frequency of approximately 2.4 GHz for receipt by a receiving antenna;

said receiving antenna in communication with a spread spectrum communication demodulator;

said spread spectrum communication demodulator in communication with a receiver code generator and with a digital demodulator;

said digital demodulator in communication with [a wide bandpass filter;

said wide bandpass filter in communication with] a channel decoder that is configured to perform soft-decision decoding;

said channel decoder in communication with a receiver decoder;

said receiver decoder in communication with a DAC;

said DAC in communication with a low pass filter to pass the analog music signal in the approximate frequency band of 20 Hz to 20 kHz; and

said low pass filter passing analog music signal will be amplified for processing to a speaker headphone set to provide high quality music for listening by a single user wearing the headphones.

9. (New) An audio music digital wireless receiver for spread spectrum communication of an audio music signal, comprising:

a receiving antenna in communication with a spread spectrum communication demodulator;

said spread spectrum communication demodulator in communication with a code generator configured to create a unique hop pattern for each individual user;

said digital demodulator in communication with [a wide bandpass filter;

said wide bandpass filter in communication with] a channel decoder that is configured to perform soft-decision decoding;

said channel decoder in communication with a decoder;

said decoder in communication with a DAC;

said DAC in communication with a low pass filter to pass the analog music signal in the approximate frequency band of 20 Hz to 20kHz; and

said low pass filter passing analog music signal will be amplified for processing to a speaker headphone set to provide high quality music for listening by a single user wearing the headphones.

10. (New) A wireless digital audio music system for spread spectrum communication of an audio music signal from the analog headphone jack connected to a battery powered spread spectrum transmitter and received by a battery powered spread spectrum headphone receiver comprising:

an analog headphone jack from an audio music source in communication with a battery powered digital transmitter;

said battery powered digital transmitter converts an analog audio music signal from said existing analog headphone jack to a digital signal using an ADC in communication with an encoder;

said encoder in communication with a channel encoder that is configured to send encoded symbols that are compatible with a Viterbi decoder;

said channel encoder in communication with [a digital low pass filter;

said digital low pass filter in communication with] a digital modulator;

said digital modulator in communication with a spread spectrum communication modulator that utilizes a code generator to create a unique hop pattern for each individual user;

said spread spectrum communication modulator in communication with a transmit antenna that transmits at a radio frequency of approximately 2.4 GHz for receipt by a receiving antenna;

said receiving antenna in communication with a spread spectrum communication demodulator;

said spread spectrum communication demodulator in communication with a receiver code generator and with a digital demodulator;

said digital demodulator in communication with a Viterbi decoder;

said Viterbi decoder in communication with a receiver decoder;

said receiver decoder in communication with a DAC;

said DAC in communication with a low pass filter to pass the analog music signal in the approximate frequency band of 20 Hz to 20 kHz; and

said low pass filter passing analog music signal will be amplified for processing to a speaker headphone set to provide high quality music for listening by a single user wearing the headphones.

11. (New) An audio music digital wireless receiver for spread spectrum communication of an audio music signal to be received by a battery powered spread spectrum headphone receiver comprising:

a receiving antenna in communication with a spread spectrum communication demodulator;

said spread spectrum communication demodulator in communication with a code generator configured to create a unique hop pattern for each individual user;

said digital demodulator in communication with a Viterbi decoder;

said Viterbi decoder in communication with a decoder;

said decoder in communication with a DAC;

said DAC in communication with a low pass filter to pass the analog music signal in the approximate frequency band of 20 Hz to 20kHz; and

said low pass filter passing analog music signal will be amplified for processing to a speaker headphone set to provide high quality music for listening by a single user wearing the headphones.

12. (New) A wireless digital audio music system for spread spectrum communication of an audio music signal from the analog headphone jack connected to a battery powered spread spectrum transmitter and received by a battery powered spread spectrum headphone receiver comprising:

an analog headphone jack from an audio music source in communication with a battery powered digital transmitter;

said battery powered digital transmitter converts an audio music signal from said existing analog headphone jack to a digital signal using an ADC in communication with an encoder;



said encoder in communication with a channel encoder;  
said channel encoder in communication with [a digital low pass filter;  
said digital low pass filter in communication with] a digital modulator;  
said digital modulator in communication with a spread spectrum communication modulator that utilizes a code generator to create a unique hop pattern for an individual user;

said spread spectrum communication modulator in communication with a transmit antenna that transmits at a radio frequency of approximately 2.4 GHz for receipt by a receiving antenna;

said receiving antenna in communication with a spread spectrum communication demodulator;

a 2.4 GHz direct conversion receiver that includes a spread spectrum communication demodulator and a receiver code generator;

said spread spectrum communication demodulator in communication with said receiver code generator and with a digital demodulator;

said digital demodulator in communication with [a wide bandpass filter;

said wide bandpass filter in communication with] a channel decoder;

said channel decoder in communication with a receiver decoder;

said receiver decoder in communication with a DAC;

said DAC in communication with a low pass filter to pass the analog music signal in the approximate frequency band of 20 Hz to 20 kHz; and

said low pass filter passing analog music signal will be amplified for processing to a speaker headphone set to provide high quality music for listening by a single user wearing the headphones.

13. (New) An audio music digital wireless receiver for spread spectrum communication of an audio music signal, comprising:

a receiving antenna in communication with a 2.4 GHz direct conversion receiver, wherein the direct conversion receiver includes a spread spectrum communication

demodulator in communication with a code generator, said code generator being configured to create a unique hop pattern for each individual user;

said digital demodulator in communication with [a wide bandpass filter;

said wide bandpass filter in communication with] a channel decoder;

said channel decoder in communication with a decoder;

said decoder in communication with a DAC;

said DAC in communication with a low pass filter to pass the analog music signal in the approximate frequency band of 20 Hz to 20kHz; and

said low pass filter passing analog music signal will be amplified for processing to a speaker headphone set to provide high quality music for listening by a single user wearing the headphones.

**Amendments to the Drawings:**

The drawings were objected to as incorporating new matter because of the altered order of the filter in relation to other elements. Corrected drawings were required because of the altered order of the filter in Figs. 2 and 3. More particularly, with respect to Fig. 2, the low pass filter was shown between the ADC and encoder, thus differing from the drawings in the parent application. With respect to Fig. 3, the bandpass filter was shown in a different order from that shown in the parent.

In order to expedite matters, Applicant has deleted the low pass filter of Fig. 2 as well as the bandpass filter of Fig. 3. These filters are often included with analog-to-digital converters and demodulators such as those shown in Figs. 2 and 3.

Moreover, Applicant has specified in Fig. 3 that the channel decoder 66 is a Viterbi channel decoder. Also in Fig. 3, Applicant has specified that the receiver is a direct conversion receiver. Each of these elements was originally found in Applicant's parent specification.

ATTACHMENTS: 1 ANNOTATED SHEET AND 2 REPLACEMENT SHEETS

### **REMARKS**

Applicant would like to thank Examiner Xu Mei and Examiner Andrew Graham for discussing the claims on January 26, 2006 at 2:00 p.m. EST.

Claims 1, 4, 6 and 7 remain pending in this application. These claims have been amended to further clarify the scope of the invention for the reasons set forth below. Moreover, new Claims 8-13 have been added with additional limitations discussed in the Examiner interview.

#### **Rejection under 35 USC 132-New Matter**

The specification was objected to under 35 USC 132 as allegedly incorporating new matter. More particularly, the specification was objected to based on a throughput rate "that may be as low as approximately 1.0 Mbps." Applicant's disclosure provided that the throughput may be approximately 1.4 Mbps. Accordingly, Applicant submits that the phrase objected to was not new matter. However, in order to further expedite prosecution, Applicant has deleted this language from the specification. Accordingly, Applicant requests that this objection be withdrawn.

#### **Rejection under 35 USC 112, 1st paragraph**

Claims 1 and 6 stand rejected under 35 USC 112, 1st paragraph, as allegedly failing to comply with the written description requirement. More particularly, the office action provided that the limitation "an ADC in communication with an encoder at a signal rate of less than approximately 1.0 Mbps" incorporated new matter because there was no support for this throughput rate between the ADC and encoder. Applicant has

amended the cited claims to read -- an ADC in communication with an encoder--, deleting the reference to the signal rate. Accordingly, Applicant submits that this rejection has been overcome.

### **Rejections under 35 USC 103**

Claims 1, 4, 6 and 7 were rejected under 35 USC 103 as allegedly being unpatentable over Alstatt (USPN 5771441) in view of Schotz et al (USPN 5946343) and further in view of Schotz (USPN 5491839).

Applicant respectfully submits that a *prima facie* case of obviousness has not been made since the references do not teach or suggest all claim limitations. Claims 1, 4 and 6 require a code generator that generates or modulates a "user code" that creates a unique hop pattern for each individual user. The present invention uses frequency hopping spread spectrum (FHSS) transmission technology with a unique pseudo-noise (PN) code that is long enough, and that has low cross-correlation properties so that the hop pattern is unique for each individual user. FHSS employs a data signal that is modulated with a narrowband carrier signal that "hops" in a random but predictable sequence from frequency to frequency as a function of time over a wide band of frequencies. The signal energy is spread in the time domain--as opposed to severing each bit into small pieces in the frequency domain. The FHSS technique reduces interference because a signal from a narrowband system may only affect the spread spectrum signal if both are transmitting at the same frequency at the same time. If synchronized properly, a single logical channel is maintained. With FHSS, the transmission frequencies are determined by the PN code.

The receiver is set to the same hopping code and listens to the incoming signal at the right time and correct frequency.

By contrast, Schotz uses "one of four different PN sequences." (See Schotz '343 at Col. 16:61 to Col. 17:2) These codes are assigned to specific devices for a single household--not individual users. As such, the Schotz code may be properly deemed a "device code" as opposed to a "user code" as in the present invention. There is no mention in Schotz that the PN code must support individual users operating within the same space. By contrast, the present invention addresses the interference between individual users [parent specification/page4/lines16-22] and each PN code and its hopping sequence is generated to address the needs of individual users. (See e.g., paras. 0009 and 0011 of the present disclosure.)

While Applicant submits that the references did not teach or suggest all claim limitations as presented, Applicant has amended Claims 1, 4 and 6 to recite "a code generator" that creates "a unique hop pattern for each individual user." This amendment is made to further clarify the scope of the invention. Moreover, this limitation has been added to Claim 7, and all new Claims 8-13 further include this limitation. Accordingly, Applicant submits that the claims clearly state that this code generator is used to create a unique hop pattern for each individual user, a limitation not taught or suggested by the prior art references. Accordingly, Applicant respectfully submits that this rejection has been overcome.

Moreover, a *prima facie* case of obviousness was not made because the references do not teach or suggest the limitation directed to an analog battery-powered digital

transmitter. The office action provides that the combination of Alstatt and Schotz's '343 Patent teaches a battery powered digital transmitter. Applicant respectfully submits that a *prima facie* case of obviousness has not been made. More particularly, the combination of the battery-powered analog transmitter of Alstatt and the wall-powered digital transmitter of Schotz '343 would render Alstatt unsatisfactory for its intended purpose. Alstatt would suffer from a significantly reduced play time due to the power consumption of Schotz's numerous integrated circuits. Moreover, the Alstatt headphones for his portable device would be rendered too large because of the size of the integrated circuits used in Schotz.

For the same reasons of reduced play time and unwieldy headphones, the combination of Alstatt and Schotz would not provide a reasonable expectation of success. Accordingly, Applicant respectfully submits that a *prima facie* case of obviousness has not been made in this respect as well.

New limitations have been added to the new Claims 8-13, as discussed in Applicant's Examiner interview. New Claims 8 and 9 have been added to recite a channel decoder that permits soft-decision decoding. New Claims 10-11 have been added to recite a channel decoder that is a Viterbi decoder. (For further clarification, Claim 10, directed to the system, includes a limitation that the channel encoder is configured to send encoded symbols that are compatible with a Viterbi decoder). The specification has also been amended to recite that the channel decoder may be a Viterbi decoder. This material was present in the parent application to which the present application claims priority. [See page 4, line 27 of the parent application]

The Viterbi decoder--or a channel decoder that permits soft-decision decoding--is not taught or suggested by the prior art references. Schotz incorporates a 1/2 rate extended Golay block coding scheme. (Col. 9:19-26) Schotz's block coding scheme differs significantly from the coding scheme of the present claims. More particularly, soft-decision coding may be used to prevent a greater band of interference than the Golay block coding scheme.

While the Viterbi channel encoding/decoding scheme permits hard decision coding as found in Schotz, it is the ability of this Viterbi scheme to further permit soft-decision coding that permits the Viterbi scheme to suppress a broader range of interference from other users. The Viterbi channel encoding/decoding scheme prevents interference (or jamming) from other system users. This interference can be represented as follower (or repeater) interference.

The follower (or repeater) jammer transmits frequency-hopped narrowband interference using the same hop sequence as the communicator, where the communicator is the primary user. This is equivalent to at least one additional system user in operation within the same space (or range) of a primary user. The follower (or repeater) jammers' output--resulting from use by other system users--must arrive at the primary user's frequency-hopping receiver hop frequency band space and dwell there long enough to cause interference before hopping to the next hop frequency band. The partial band jammer that is referenced in Schotz's design is defined as a transmitter (non-hopping type) that transmits its available power into a limited bandwidth which is smaller than the spread spectrum bandwidth. (See Schotz '343, para. 0016, lines 1-5)



Contrary to hard-decision decoding, soft-decision decoding includes additional information symbols to determining the reliability of the symbols being decoded. Included in the additional information symbols of the present invention is jammer state information (JSI). JSI includes information regarding the potential jamming threat, including the hop rate, dwell time, bandwidth, and so on, that would cause interference in the system of the present disclosure. The JSI permits the receiver headphones to know if other system users are in the area, and if so, then the Viterbi decoder assigns less weight to the symbols that may be jammed so that it makes the a better estimate of the transmitted code sequence.

The Schotz design uses hard-decision decoding (see e.g., reference SRT241203) that does not incorporate JSI, as required with soft-decision decoding. In addition, Schotz states that forward error correction (see e.g., SRT241203) can be eliminated by frequency hopping is used in his design. (See Schotz para. 0016, lines 5-10)

Repeater jamming interference occurs when other system users are within relatively close range to one another. In accordance with the present invention, a repeater jammer transmits frequency-hopped narrow band interference using the same hop rate and dwell time as the primary user. This is the case for one or more other system users, because the same hop rate and dwell time is used for all system users, but each has a different PN code sequence. So, the repeater jammer (represented by other system users) may transmit an interference signal that may hop along with the primary system user to create interference in the receiver headphones of the primary system user. Schotz does not suppress this type of interference.

Schotz provides states that his system adds “control information” so there is no “need for independent stereos” in the same space. (See Schotz Abstract). Accordingly, Schotz does not design his system to function with multiple users (i.e., multiple stereos) in the same space. In fact, he teaches away from the use of independent stereos.

Schotz states the forward error correction is not needed (See Schotz at Column16:1-10). Further, the hard-decision decoder Schotz uses does not apply additional confidence symbols (like JSI) to maximize accurate decoding.

New Claims 12 and 13 have also been added to recite a 2.4 GHz direct conversion receiver. These receivers are compatible with systems incorporating frequency hopping spread spectrum (FHSS) transmission technology. Applicant respectfully submits that the prior art does not teach or suggest a direct conversion receiver. Schotz '343 incorporates a superheterodyne receiver that uses quadrature phase-shift keying as a modulation technique. This superheterodyne receiver incorporates filtering, oscillator and frequency synthesis components that are not needed when a direct conversion receiver is used. Moreover, at the time of Applicant's invention, the QPSK modulation technique was not compatible with modulation using frequency shift keying (FSK), so Schotz does not suggest a direct conversion receiver.

#### **Clarifying Amendments**

Minor amendments have further been made to the claims in order to correct typographical errors. More particularly, Claim 4 has been amended to recite that the method comprises the steps of various elements, with steps being plural instead of

singular. Claim 4 has also been amended to recite, as part of the method "*communicating*" said analog music signal instead of "communication". Further, Claim 4 has been amended to delete reference to a distance of reception. The preambles of Claims 6 and 7 have been amended to delete reference, respectively, to "an analog headphone jack connected to a battery powered spread spectrum transmitter" and "to be received by a battery powered spread spectrum headphone receiver." A semicolon has been added after the first element of Claim 7 directed to "a receiving antenna in communication with a spread spectrum headphone receiver."

Claim 6 has also been amended to recite that the battery powered digital transmitter is *configured to convert* an analog audio music signal, as opposed to "converts" an analog audio music signal.

### **Conclusion**

Applicant respectfully submits that the claims are in condition for allowance. A notice of allowance is respectfully requested.

While Applicant does not believe any fees are necessary since this response is submitted within the two-month window after the December 30, 2005 office action. However, if any such fees are deemed necessary, please charge any additional fees which may be required, or credit overpayment to Deposit Account No. 50-1946, referencing number 073785-0013.

Serial No.: 10/648,012  
Amdt. Dated: February 10, 2006  
Reply to Office Action of December 30, 2005

Attorney Docket No.: 73785-013

Respectfully submitted,

February 10, 2006  
Date

Daphne L. Burton  
Daphne L. Burton  
Registration No. 45,323

MCDERMOTT WILL & EMERY, LLP  
2049 Century Park East, 34th Floor  
Los Angeles, CA 90067  
Telephone: (310) 277-4110  
Facsimile: (310) 277-4730

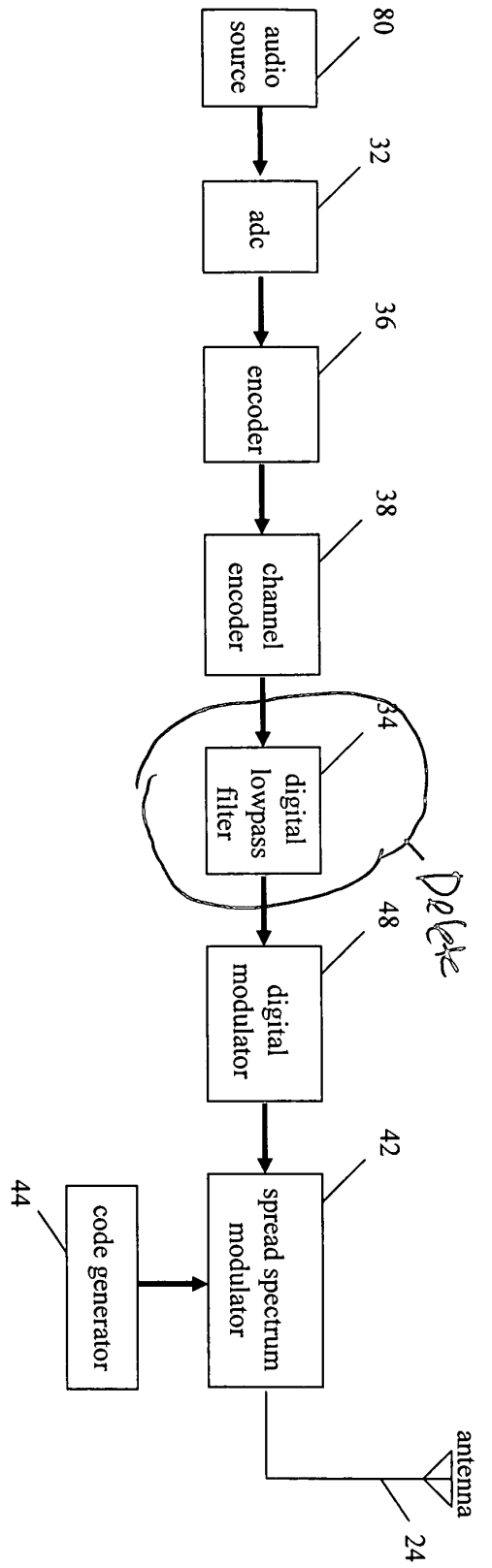

Figure 2

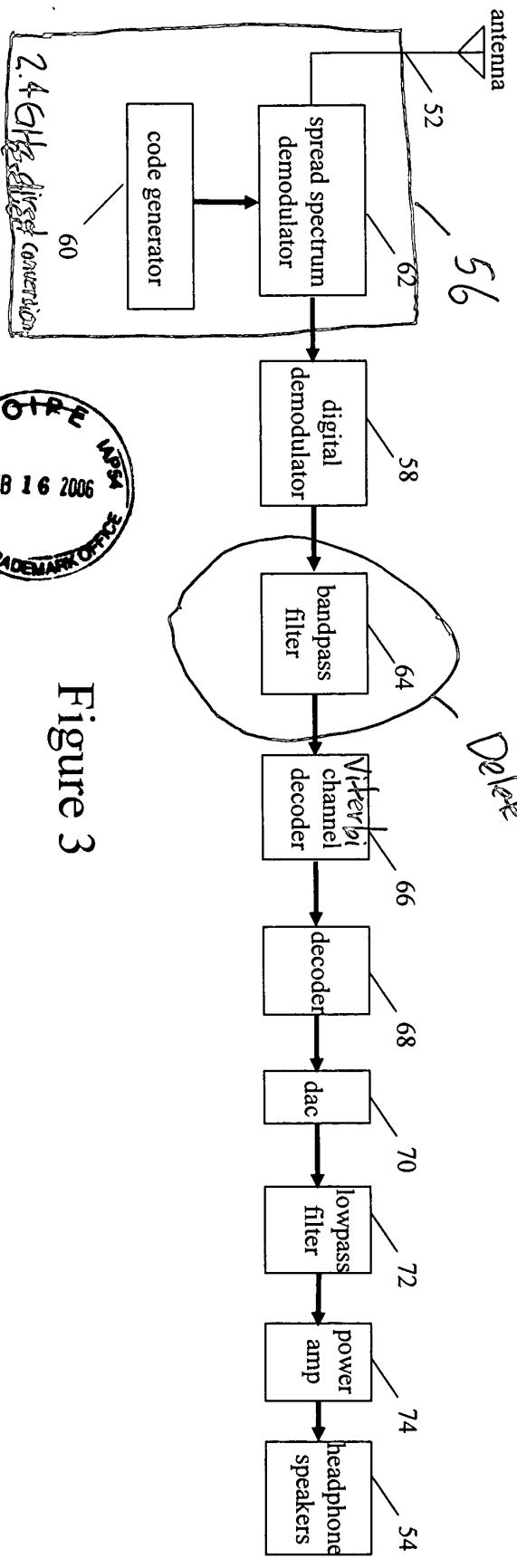

Figure 3



2.4 GHz Direct Connection

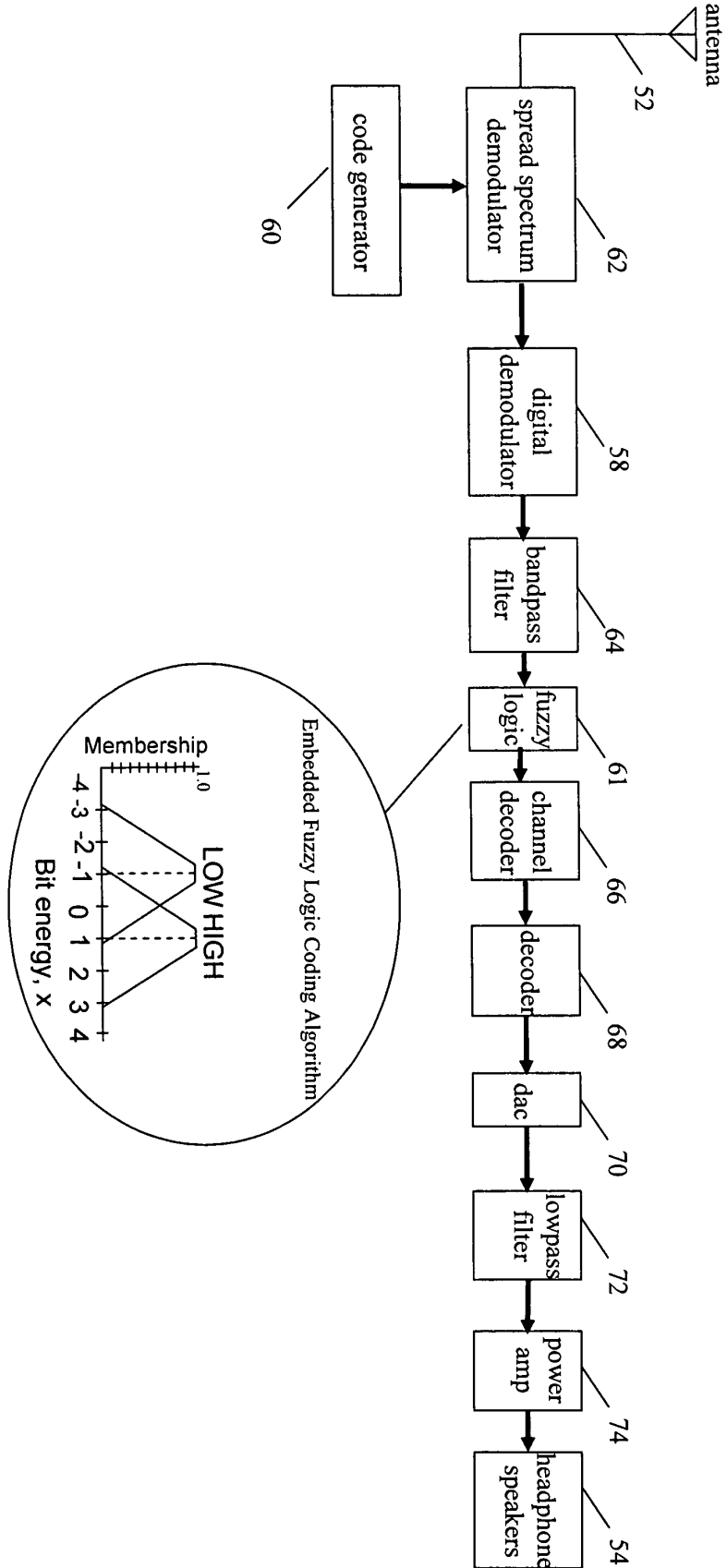

Figure 4

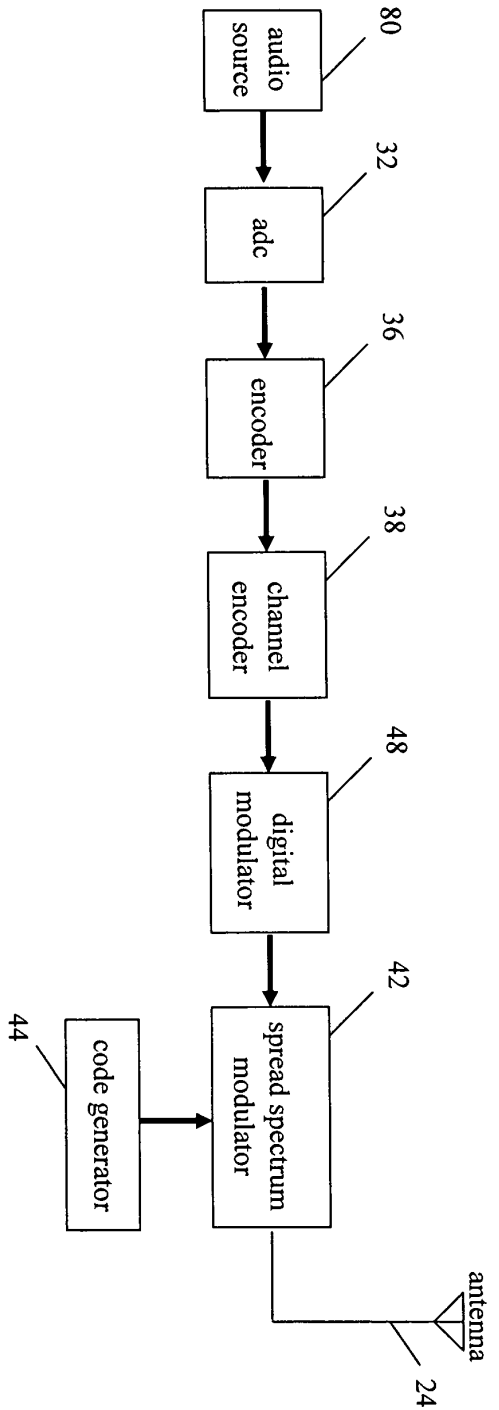

Figure 2

REPLACEMENT SHEET

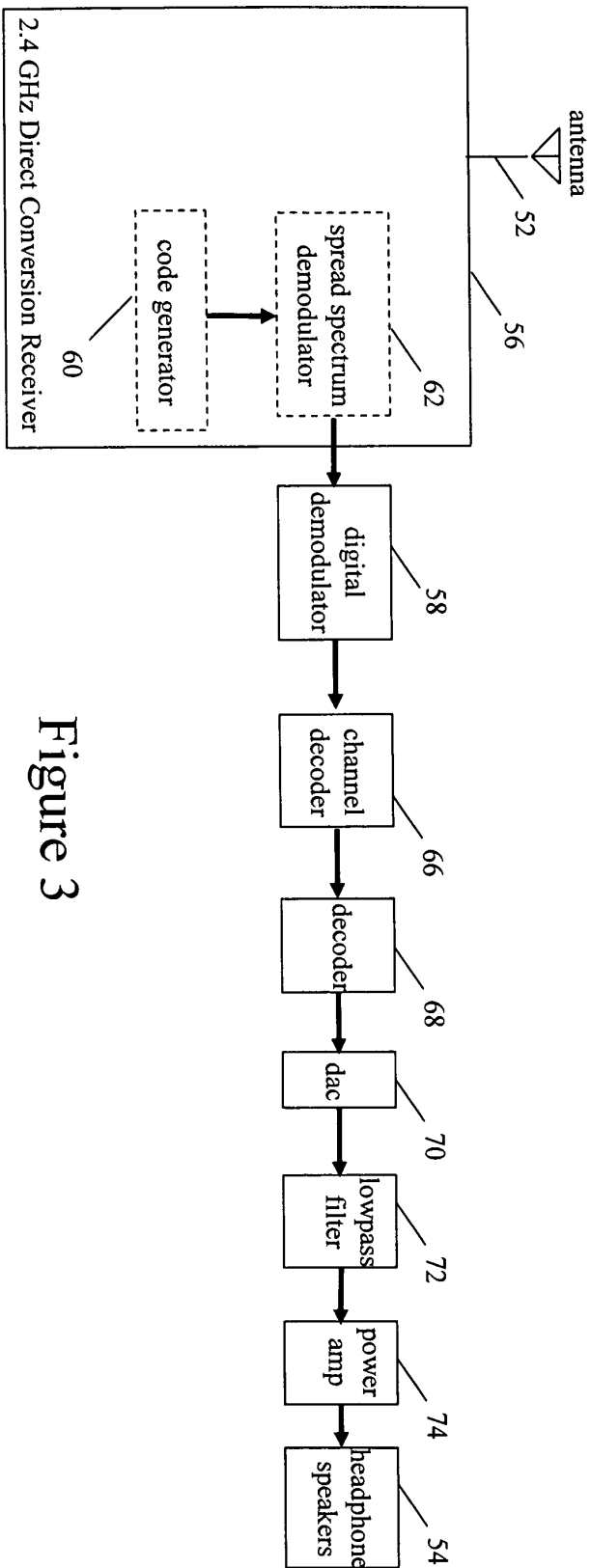

Figure 3

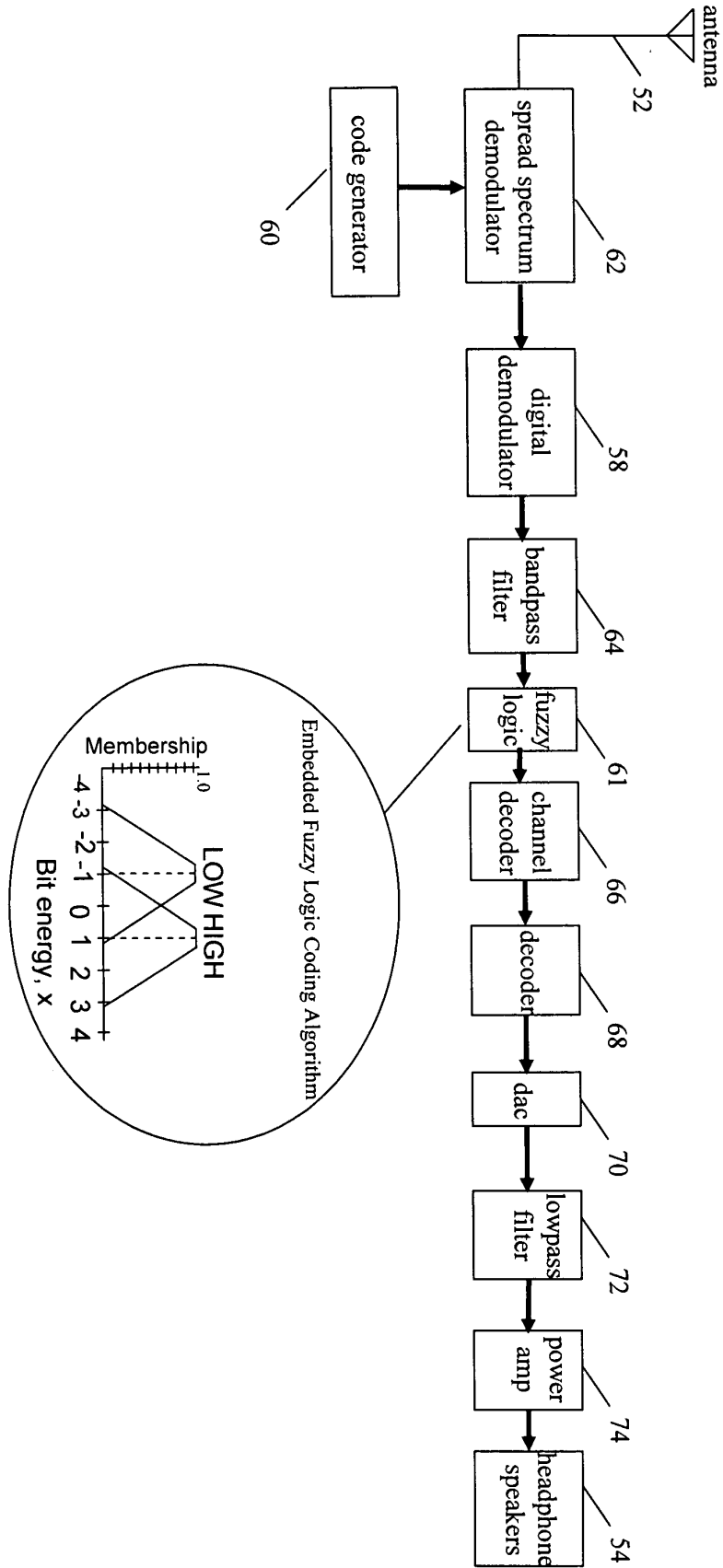

Figure 4



**PATENT APPLICATION FEE DETERMINATION RECORD**  
Effective January 1, 2003

Application or Docket Number

10/695012

**CLAIMS AS FILED - PART I**

	(Column 1)	(Column 2)
TOTAL CLAIMS	5	
FOR	NUMBER FILED	NUMBER EXTRA
TOTAL CHARGEABLE CLAIMS	5 minus 20 =	0
INDEPENDENT CLAIMS	3 minus 3 =	0
MULTIPLE DEPENDENT CLAIM PRESENT	<input type="checkbox"/>	

\* If the difference in column 1 is less than zero, enter "0" in column 2

**CLAIMS AS AMENDED - PART II**

2/25/05

	(Column 1)	(Column 2)	(Column 3)
AMENDMENT A	CLAIMS REMAINING AFTER AMENDMENT	HIGHEST NUMBER PREVIOUSLY PAID FOR	PRESENT EXTRA
Total	* 5 Minus	** 20	= 0
Independent	* 3 Minus	*** 3	= 0
FIRST PRESENTATION OF MULTIPLE DEPENDENT CLAIM	<input type="checkbox"/>		

2/16/06

	(Column 1)	(Column 2)	(Column 3)
AMENDMENT B	CLAIMS REMAINING AFTER AMENDMENT	HIGHEST NUMBER PREVIOUSLY PAID FOR	PRESENT EXTRA
Total	* 10 Minus	** 20	= 0
Independent	* 10 Minus	*** 4	= 6
FIRST PRESENTATION OF MULTIPLE DEPENDENT CLAIM	<input type="checkbox"/>		

	(Column 1)	(Column 2)	(Column 3)
AMENDMENT C	CLAIMS REMAINING AFTER AMENDMENT	HIGHEST NUMBER PREVIOUSLY PAID FOR	PRESENT EXTRA
Total	* Minus	**	=
Independent	* Minus	***	=
FIRST PRESENTATION OF MULTIPLE DEPENDENT CLAIM	<input type="checkbox"/>		

\* If the entry in column 1 is less than the entry in column 2, enter "0" in column 3.  
 \*\* If the "Highest Number Previously Paid For" IN THIS SPACE is less than 20, enter "20".  
 \*\*\* If the "Highest Number Previously Paid For" IN THIS SPACE is less than 3, enter "3".  
 The "Highest Number Previously Paid For" (Total or Independent) is the highest number found in the appropriate box in column 1.

SMALL ENTITY TYPE  OR OTHER THAN SMALL ENTITY

RATE	FEE	OR	RATE	FEE
BASIC FEE	375.00	OR	BASIC FEE	750.00
X\$ 9=		OR	X\$18=	
X42=		OR	X84=	
+140=		OR	+280=	
TOTAL	375	OR	TOTAL	

SMALL ENTITY OR OTHER THAN SMALL ENTITY

RATE	ADDITIONAL FEE	OR	RATE	ADDITIONAL FEE
X\$ 9=		OR	X\$18=	
X42=		OR	X84=	
+140=		OR	+280=	
TOTAL ADDIT. FEE		OR	TOTAL ADDIT. FEE	

RATE	ADDITIONAL FEE	OR	RATE	ADDITIONAL FEE
X\$ 9=		OR	X\$18=	
X42=	600	OR	X84=	
+140=		OR	+280=	
TOTAL ADDIT. FEE	600	OR	TOTAL ADDIT. FEE	

RATE	ADDITIONAL FEE	OR	RATE	ADDITIONAL FEE
X\$ 9=		OR	X\$18=	
X42=		OR	X84=	
+140=		OR	+280=	
TOTAL ADDIT. FEE		OR	TOTAL ADDIT. FEE	



UNITED STATES PATENT AND TRADEMARK OFFICE

UNITED STATES DEPARTMENT OF COMMERCE  
United States Patent and Trademark Office  
Address: COMMISSIONER FOR PATENTS  
P.O. Box 1450  
Alexandria, Virginia 22313-1450  
www.uspto.gov

APPLICATION NO.	FILING DATE	FIRST NAMED INVENTOR	ATTORNEY DOCKET NO.	CONFIRMATION NO.
10/648,012	08/26/2003	C. Earl Woolfork	73785-013	3337
	7590	03/07/2006	EXAMINER	
ATTN: Daphne L. Burton McDERMOTT, WILL & EMERY, LLP 34th Floor 2049 Century Park East Los Angeles, CA 90067			GRAHAM, ANDREW R	
			ART UNIT	PAPER NUMBER
			2644	

DATE MAILED: 03/07/2006

Please find below and/or attached an Office communication concerning this application or proceeding.

**Advisory Action  
Before the Filing of an Appeal Brief**

Application No.

10/648,012

Applicant(s)

WOOLFORK, C. EARL

Examiner

Andrew Graham

Art Unit

2644

--The MAILING DATE of this communication appears on the cover sheet with the correspondence address --

THE REPLY FILED 16 February 2006 FAILS TO PLACE THIS APPLICATION IN CONDITION FOR ALLOWANCE.

1.  The reply was filed after a final rejection, but prior to or on the same day as filing a Notice of Appeal. To avoid abandonment of this application, applicant must timely file one of the following replies: (1) an amendment, affidavit, or other evidence, which places the application in condition for allowance; (2) a Notice of Appeal (with appeal fee) in compliance with 37 CFR 41.31; or (3) a Request for Continued Examination (RCE) in compliance with 37 CFR 1.114. The reply must be filed within one of the following time periods:

- a)  The period for reply expires \_\_\_\_\_ months from the mailing date of the final rejection.
- b)  The period for reply expires on: (1) the mailing date of this Advisory Action, or (2) the date set forth in the final rejection, whichever is later. In no event, however, will the statutory period for reply expire later than SIX MONTHS from the mailing date of the final rejection.

Examiner Note: If box 1 is checked, check either box (a) or (b). ONLY CHECK BOX (b) WHEN THE FIRST REPLY WAS FILED WITHIN TWO MONTHS OF THE FINAL REJECTION. See MPEP 706.07(f).

Extensions of time may be obtained under 37 CFR 1.136(a). The date on which the petition under 37 CFR 1.136(a) and the appropriate extension fee have been filed is the date for purposes of determining the period of extension and the corresponding amount of the fee. The appropriate extension fee under 37 CFR 1.17(a) is calculated from: (1) the expiration date of the shortened statutory period for reply originally set in the final Office action; or (2) as set forth in (b) above, if checked. Any reply received by the Office later than three months after the mailing date of the final rejection, even if timely filed, may reduce any earned patent term adjustment. See 37 CFR 1.704(b).

NOTICE OF APPEAL

2.  The Notice of Appeal was filed on \_\_\_\_\_. A brief in compliance with 37 CFR 41.37 must be filed within two months of the date of filing the Notice of Appeal (37 CFR 41.37(a)), or any extension thereof (37 CFR 41.37(e)), to avoid dismissal of the appeal. Since a Notice of Appeal has been filed, any reply must be filed within the time period set forth in 37 CFR 41.37(a).

AMENDMENTS

3.  The proposed amendment(s) filed after a final rejection, but prior to the date of filing a brief, will not be entered because

(a)  They raise new issues that would require further consideration and/or search (see NOTE below);

(b)  They raise the issue of new matter (see NOTE below);

(c)  They are not deemed to place the application in better form for appeal by materially reducing or simplifying the issues for appeal; and/or

(d)  They present additional claims without canceling a corresponding number of finally rejected claims.

NOTE: See Continuation Sheet. (See 37 CFR 1.116 and 41.33(a)).

4.  The amendments are not in compliance with 37 CFR 1.121. See attached Notice of Non-Compliant Amendment (PTOL-324).

5.  Applicant's reply has overcome the following rejection(s): \_\_\_\_\_.

6.  Newly proposed or amended claim(s) \_\_\_\_\_ would be allowable if submitted in a separate, timely filed amendment canceling the non-allowable claim(s).

7.  For purposes of appeal, the proposed amendment(s): a)  will not be entered, or b)  will be entered and an explanation of how the new or amended claims would be rejected is provided below or appended.

The status of the claim(s) is (or will be) as follows:

Claim(s) allowed: \_\_\_\_\_.

Claim(s) objected to: \_\_\_\_\_.

Claim(s) rejected: \_\_\_\_\_.

Claim(s) withdrawn from consideration: \_\_\_\_\_.

AFFIDAVIT OR OTHER EVIDENCE

8.  The affidavit or other evidence filed after a final action, but before or on the date of filing a Notice of Appeal will not be entered because applicant failed to provide a showing of good and sufficient reasons why the affidavit or other evidence is necessary and was not earlier presented. See 37 CFR 1.116(e).

9.  The affidavit or other evidence filed after the date of filing a Notice of Appeal, but prior to the date of filing a brief, will not be entered because the affidavit or other evidence failed to overcome all rejections under appeal and/or appellant fails to provide a showing of a good and sufficient reasons why it is necessary and was not earlier presented. See 37 CFR 41.33(d)(1).

10.  The affidavit or other evidence is entered. An explanation of the status of the claims after entry is below or attached.

REQUEST FOR RECONSIDERATION/OTHER

11.  The request for reconsideration has been considered but does NOT place the application in condition for allowance because: \_\_\_\_\_.

12.  Note the attached Information Disclosure Statement(s). (PTO/SB/08 or PTO-1449) Paper No(s). \_\_\_\_\_

13.  Other: \_\_\_\_\_.

*AG*  
Andrew Graham  
571-272-7517

Continuation Sheet (PTOL-303)

Application No.

Continuation of 3. NOTE: So far as the "unique hop pattern" is different or alleged to be different from the previously considered "user code", such an amendment would require further search and/or consideration. Also, certain claims now specify a "Viterbi" decoder, which, in comparison with what was previously considered, would also require further search and/or consideration.



**SINH TRAN**  
**SUPERVISORY PATENT EXAMINER**

**Notice of Non-Compliant  
Amendment (37 CFR 1.121)**

Application No.

10/648,012

Examiner

Andrew Graham

Applicant(s)

WOOLFORK, C. EARL

Art Unit

2644

-- The MAILING DATE of this communication appears on the cover sheet with the correspondence address --

The amendment document filed on 16 February 2006 is considered non-compliant because it has failed to meet the requirements of 37 CFR 1.121 or 1.4. In order for the amendment document to be compliant, correction of the following item(s) is required.

THE FOLLOWING MARKED (X) ITEM(S) CAUSE THE AMENDMENT DOCUMENT TO BE NON-COMPLIANT:

- 1. Amendments to the specification:
  - A. Amended paragraph(s) do not include markings.
  - B. New paragraph(s) should not be underlined.
  - C. Other \_\_\_\_\_.
- 2. Abstract:
  - A. Not presented on a separate sheet. 37 CFR 1.72.
  - B. Other \_\_\_\_\_.
- 3. Amendments to the drawings:
  - A. The drawings are not properly identified in the top margin as "Replacement Sheet," "New Sheet," or "Annotated Sheet" as required by 37 CFR 1.121(d).
  - B. The practice of submitting proposed drawing correction has been eliminated. Replacement drawings showing amended figures, without markings, in compliance with 37 CFR 1.84 are required.
  - C. Other \_\_\_\_\_.
- 4. Amendments to the claims:
  - A. A complete listing of all of the claims is not present.
  - B. The listing of claims does not include the text of all pending claims (including withdrawn claims)
  - C. Each claim has not been provided with the proper status identifier, and as such, the individual status of each claim cannot be identified. Note: the status of every claim must be indicated after its claim number by using one of the following status identifiers: (Original), (Currently amended), (Canceled), (Previously presented), (New), (Not entered), (Withdrawn) and (Withdrawn-currently amended).
  - D. The claims of this amendment paper have not been presented in ascending numerical order.
  - E. Other: See Continuation Sheet.
- 5. Other (e.g., the amendment is unsigned or not signed in accordance with 37 CFR 1.4):  
\_\_\_\_\_

For further explanation of the amendment format required by 37 CFR 1.121, see MPEP § 714.

TIME PERIODS FOR FILING A REPLY TO THIS NOTICE:

1. Applicant is given **no new time period** if the non-compliant amendment is an after-final amendment or an amendment filed after allowance. If applicant wishes to resubmit the non-compliant after-final amendment with corrections, the **entire corrected amendment** must be resubmitted.
2. Applicant is given **one month**, or thirty (30) days, whichever is longer, from the mail date of this notice to supply the correction, if the non-compliant amendment is one of the following: a preliminary amendment, a non-final amendment (including a submission for a request for continued examination (RCE) under 37 CFR 1.114), a supplemental amendment filed within a suspension period under 37 CFR 1.103(a) or (c), and an amendment filed in response to a *Quayle* action. If any of above boxes 1. to 4. are checked, the correction required is only the **corrected section** of the non-compliant amendment in compliance with 37 CFR 1.121.

**Extensions of time** are available under 37 CFR 1.136(a) only if the non-compliant amendment is a non-final amendment or an amendment filed in response to a *Quayle* action.

**Failure to timely respond** to this notice will result in:

**Abandonment** of the application if the non-compliant amendment is a non-final amendment or an amendment filed in response to a *Quayle* action; or

**Non-entry** of the amendment if the non-compliant amendment is a preliminary amendment or supplemental amendment.

Legal Instruments Examiner (LIE), if applicable

Telephone No.

Continuation of 4(e) Other: Single brackets "[" and "]" are not valid claim markings. Double brackets may only be used for five or fewer characters or situations where strikethrough might not easily be perceived, not several words of claim limitations. "New" claims in the amendment have brackets in them which appear to be for showing deleted text; this is improper as the claims are "New" and not "Currently amended".



**SINH TRAN**  
**SUPERVISORY PATENT EXAMINER**



PATENT

IN THE UNITED STATES PATENT AND TRADEMARK OFFICE

Re Application of:  
C. Earl Woolfork

Group Art Unit: 2644

Examiner: Andrew Graham

Serial No.: 10/648,012

Filed: August 26, 2003

For: WIRELESS DIGITAL AUDIO  
MUSIC SYSTEM

CERTIFICATE OF MAILING (37 C.F.R. § 1.8(a))

I hereby certify that this correspondence is being deposited with the United States Postal Service as First Class Mail under 37 CFR 1.8(a) in an envelope addressed to, Mail Stop: Amendment, Commissioner for Patents, P.O. Box 1450, Alexandria, VA 22313-1450 on February 10, 2006.

Anita Chou

AMENDMENT

Mail Stop Amendment  
Commissioner for Patents  
P.O. Box 1450  
Alexandria, VA 22313-1450

Sir:

In response to the Office action mailed on December 30, 2005, please amend the above-identified application as indicated below.

**Amendments to the Specification** begin on page 2 of this paper.

**Amendments to the Claims** are reflected in the listing of claims which begins on page 3 per 37.C.F.R.1.121 of this paper.

**Amendments to the Drawings** begin on page 12 of this paper and included is both an attached replacement sheet and an annotated sheet showing changes.

**Remarks** begin on page 13 of this paper.

OK to  
Enter  
upon  
filing  
RCE,  
though it  
should be  
noted that  
the claim  
amendments  
are  
non-compliant  
per 37.C.F.R.1.121  
3.1.06

02/17/2006 BABRAHAI 00000035 501946 10648012

01 FC:2201 600.00 DA

LAS99 1439267-1.073785.0013

Serial No.: 10/648,012

Attorney Docket No.: 073758-0013

**IN THE UNITED STATES PATENT AND TRADEMARK OFFICE**In re Application of:  
C. Earl Woolfork

Group Art Unit: 2644

Serial No.: 10/648,012

Examiner: Andrew R. Graham

Filed: August 26, 2003

For: WIRELESS DIGITAL AUDIO  
SYSTEM**RECEIVED  
CENTRAL FAX CENTER  
MAR 13 2006****CERTIFICATE OF FACSIMILE TRANSMISSION UNDER 37 C.F.R. § 1.6(d)**

I hereby certify that this correspondence is being transmitted via facsimile to 571-273-8300 under 37 CFR 1.6(d) on the date below.

Date: 3/13/06  
Anita ChouCommissioner for Patents  
P.O. Box 1450  
Alexandria, VA 22313-1450**TELEPHONE INTERVIEW SUMMARY**

Sir:

The courtesy extended by Examiner Andrew Graham and Examiner Xu Mei during a telephone conversation held on January 26, 2006 is appreciated. During the telephone discussion, Applicant indicated an intent to cancel certain elements that allegedly contained new matter. Moreover, Applicant raised arguments as to why there was no motivation to combine the references in that the modification would render the prior art unsatisfactory for its intended purpose. Applicant also argued that the user code presented in the claims was different from Schotz's house code. Amendments were discussed to further clarify Applicant's user code. Moreover, possible amendments were discussed related to a Viterbi decoder and a 2.4 GHz direct conversion receiver. No agreement was reached as to the claims.

LAS99 1446643-1.073785.0013



Serial No.: 10/648,012

Attorney Docket No.: 073758-0013

It is believed that no extension of time is needed. However, in case an extension of time is needed, to the extent necessary, a petition for an extension of time under 37 C.F.R. 1.136 is hereby made. Please charge any shortage in fees due in connection with the filing of this paper, including extension of time fees, to Deposit Account 501946 and please credit any excess fees to such deposit account.

Respectfully submitted,

MCDERMOTT, WILL &amp; EMERY LLP

Respectfully submitted,

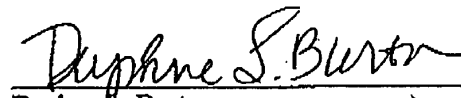

Daphne L. Burton  
Registration No. 45,323

March 13, 2006  
Date

MCDERMOTT WILL & EMERY LLP  
2049 Century Park East, 34th Floor  
Los Angeles, CA 90067  
Telephone: (310) 277-4110  
Facsimile: (310) 277-4730

LAS99 1446643-1.073785.0013

Customer No. 33401

Attorney Docket No. 73785-013

**PATENT**

**IN THE UNITED STATES PATENT AND TRADEMARK OFFICE**

In re Application of:  
C. Earl Woolfork

Group Art Unit: 2644

Serial No.: 10/648,012

Examiner: Andrew Graham

Filed: August 26, 2003

For: **WIRELESS DIGITAL AUDIO  
MUSIC SYSTEM**

RECEIVED  
CENTRAL FAX CENTER  
MAR 14 2006

Mail Stop RCE  
Commissioner for Patents  
P.O. Box 1450  
Alexandria, VA 22313-1450

**AMENDMENT**

Sir:

In response to the Office action mailed on December 30, 2005, please amend the above-identified application as indicated below.

**Amendments to the specification** begin on page 2 of this paper.

**Amendments to the claims** are reflected in the listing of claims which begins on page 3 of this paper.

**Amendments to the drawings** begin on page 12.

**Remarks** begin on page 13 of this paper.

LAS99 1446880-1.073785.0013

Serial No.: 10/648,012  
Amdt. Dated: March 14, 2006

Attorney Docket No.: 73785-013

**Amendments to the Specification:**

Please amend the specification as follows:

On page 6, line 10, (or paragraph [0009], line 12) please delete the following sentence:

"This digital signal has a throughput of approximately 1.4 Mbps that may be as low as approximately 1.0 Mbps."

On page 6, line 11, please delete the number "34" at the end of the sentence so that this sentence will read: "After digital conversion, the digital signal may be processed by a digital low pass filter."

At para. 0010, line 6, please delete the number "64" at the end of the sentence so that this sentence will read: "The transmitted signal from transmit antenna 24 may be received by receiving antenna 52 and communicated to a wideband bandpass filter (BPF)."

At paragraph [0016], line 1, please replace the first sentence with the following:

--The channel decoder 66 may be a Viterbi decoder. A channel decoder 66 may be in communication with the bandpass filter. --

At paragraph [0010], line 6, please add the following sentences at the beginning of this paragraph: --A digital signal may be received at antenna receiving antenna 52 and communicated to, e.g., a wideband bandpass filter. The received spread spectrum signal may then be communicated to a 2.4 GHz direct conversion receiver 56. A frequency shift keying (FSK) modulation/detection technique could be used given a frequency hopping spread spectrum (FHSS) system choice. The direct conversion receiver 56 may provide a means to convert the received signal while using timing and synchronization to capture the correct bit sequence embedded in the received spread spectrum signal. --

Serial No.: 10/648,012  
Amdt. Dated: March 14, 2006

Attorney Docket No.: 73785-013

**Amendments to the Claims:**

Please amend the claims as follows:

1. (Currently amended) A wireless digital audio music system for spread spectrum communication of an audio music signal from the analog headphone jack connected to a battery powered spread spectrum transmitter and received by a battery powered spread spectrum headphone receiver comprising:

an analog headphone jack from an analog audio music source in communication with a battery powered digital transmitter;

said battery powered digital transmitter converts an analog audio music signal from said existing analog headphone jack to a digital signal using an ADC in communication with an encoder [at a signal rate of less than approximately 1.0 Mbps];

said encoder in communication with a channel encoder;

said channel encoder in communication with [a digital low pass filter;

said digital low pass filter in communication with] a digital modulator;

said digital modulator in communication with a spread spectrum communication modulator that utilizes a code generator to create [user code] a unique hop pattern for each individual user;

said spread spectrum communication modulator in communication with a transmit antenna that transmits at a radio frequency of approximately 2.4 GHz for receipt by a receiving antenna;

said receiving antenna in communication with a spread spectrum communication demodulator;

said spread spectrum communication demodulator in communication with a receiver code generator and with a digital demodulator;

said digital demodulator in communication with [a wide bandpass filter;

said wide bandpass filter in communication with] a channel decoder;

said channel decoder in communication with a receiver decoder;

said receiver decoder in communication with a DAC;

Serial No.: 10/648,012  
Amdt. Dated: March 14, 2006

Attorney Docket No.: 73785-013

said DAC in communication with a low pass filter to pass the analog music signal in the approximate frequency band of 20 Hz to 20 kHz; and

said low pass filter passing analog music signal will be amplified for processing to a speaker headphone set to provide high quality music for listening by a single user wearing the headphones.

2. (Canceled).

3. (Canceled).

4. (Currently amended) A method for battery powered wireless communication transmission and reception of high fidelity audio music between a battery operated digital transmitter and a battery operated digital receiver headphone comprising the steps of:

connecting the plug attached to said battery operated digital transmitter to the existing analog headphone jack of an audio music source;

converting a music audio signal to a digital communication signal using an ADC in communication with an encoder;

encoding the communication signal using channel encoding;

[digital low pass filtering the communication signal;]

modulating the digital communication signal using a digital modulator;

creating a spread spectrum signal using a code generator to modulate a [unique user code] unique hop pattern for each individual user;

transmitting said spread spectrum signal at a radio frequency of approximately 2.4 GHz [at a power level for reception at a distance up to approximately 10 feet from said battery operated transmitter];

receiving said spread spectrum signal at said battery operated receiver headphones;

demodulating said spread spectrum signal;

demodulating said digital communication signal;

[bandpass filtering said digital communication signal;]

channel decoding of said digital communication signal;

Serial No.: 10/648,012  
Amdt. Dated: March 14, 2006

Attorney Docket No.: 73785-013

converting said digital communication signal back to said analog music audio signal using a decoder in communication with a DAC; and

[communication] communicating said analog music audio signal to a headphone speaker within the headphone receiver.

5. (Canceled)

6. (Currently amended) An audio music digital wireless transmitter for spread spectrum communication of an audio music signal [from an analog headphone jack connected to a battery powered spread spectrum transmitter], comprising:

an analog headphone jack from an audio music source in communication with a battery powered digital transmitter;

said battery powered digital transmitter [converts] being configured to convert an analog audio music signal from said existing analog headphone jack to a digital signal using an ADC in communication with an encoder [at a signal rate of less than approximately 1.0 Mbps];

said encoder in communication with a channel encoder;

said channel encoder in communication with [a digital low pass filter;

said digital low pass filter in communication with] a digital modulator;

said digital modulator in communication with a spread spectrum communication modulator that utilizes a code generator to create [user code] a unique hop pattern for each individual user; and

said spread spectrum communication modulator in communication with a transmit antenna that transmits at a radio frequency of approximately 2.4 GHz for receipt by a receiving antenna.

7. (Currently amended) An audio music digital wireless receiver for spread spectrum communication of an audio music signal [to be received by a battery powered spread spectrum receiver], comprising:

a receiving antenna in communication with a spread spectrum communication demodulator;

said spread spectrum communication demodulator in communication with a code generator configured to create a unique hop pattern for each individual user;

Serial No.: 10/648,012  
Amdt. Dated: March 14, 2006

Attorney Docket No.: 73785-013

said digital demodulator in communication with [a wide bandpass filter;  
said wide bandpass filter in communication with] a channel decoder;  
said channel decoder in communication with a decoder;  
said decoder in communication with a DAC;  
said DAC in communication with a low pass filter to pass the analog music signal  
in the approximate frequency band of 20 Hz to 20kHz; and

said low pass filter passing analog music signal will be amplified for processing  
to a speaker headphone set to provide high quality music for listening by a single user  
wearing the headphones.

8. (New) A wireless digital audio music system for spread spectrum  
communication of an audio music signal from the analog headphone jack connected to a  
battery powered spread spectrum transmitter and received by a battery powered spread  
spectrum headphone receiver comprising:

an analog headphone jack from an audio music source in communication with a  
battery powered digital transmitter;

said battery powered digital transmitter converts an analog audio music signal  
from said existing analog headphone jack to a digital signal using an ADC in  
communication with an encoder;

said encoder in communication with a channel encoder;

said channel encoder in communication with a digital modulator;

said digital modulator in communication with a spread spectrum communication  
modulator that utilizes a code generator to create a unique hop pattern for each individual  
user;

said spread spectrum communication modulator in communication with a transmit  
antenna that transmits at a radio frequency of approximately 2.4 GHz for receipt by a  
receiving antenna;

said receiving antenna in communication with a spread spectrum communication  
demodulator;

said spread spectrum communication demodulator in communication with a  
receiver code generator and with a digital demodulator;

Serial No.: 10/648,012  
Amdt. Dated: March 14, 2006

Attorney Docket No.: 73785-013

said digital demodulator in communication with a channel decoder that is configured to perform soft-decision decoding;

said channel decoder in communication with a receiver decoder;

said receiver decoder in communication with a DAC;

said DAC in communication with a low pass filter to pass the analog music signal in the approximate frequency band of 20 Hz to 20 kHz; and

said low pass filter passing analog music signal will be amplified for processing to a speaker headphone set to provide high quality music for listening by a single user wearing the headphones.

9. (New) An audio music digital wireless receiver for spread spectrum communication of an audio music signal, comprising:

a receiving antenna in communication with a spread spectrum communication demodulator;

said spread spectrum communication demodulator in communication with a code generator configured to create a unique hop pattern for each individual user;

said digital demodulator in communication with a channel decoder that is configured to perform soft-decision decoding;

said channel decoder in communication with a decoder;

said decoder in communication with a DAC;

said DAC in communication with a low pass filter to pass the analog music signal in the approximate frequency band of 20 Hz to 20kHz; and

said low pass filter passing analog music signal will be amplified for processing to a speaker headphone set to provide high quality music for listening by a single user wearing the headphones.

10. (New) A wireless digital audio music system for spread spectrum communication of an audio music signal from the analog headphone jack connected to a battery powered spread spectrum transmitter and received by a battery powered spread spectrum headphone receiver comprising:

an analog headphone jack from an audio music source in communication with a battery powered digital transmitter;



Serial No.: 10/648,012  
Amdt. Dated: March 14, 2006

Attorney Docket No.: 73785-013

said battery powered digital transmitter converts an analog audio music signal from said existing analog headphone jack to a digital signal using an ADC in communication with an encoder;

said encoder in communication with a channel encoder that is configured to send encoded symbols that are compatible with a Viterbi decoder;

said channel encoder in communication with a digital modulator;

said digital modulator in communication with a spread spectrum communication modulator that utilizes a code generator to create a unique hop pattern for each individual user;

said spread spectrum communication modulator in communication with a transmit antenna that transmits at a radio frequency of approximately 2.4 GHz for receipt by a receiving antenna;

said receiving antenna in communication with a spread spectrum communication demodulator;

said spread spectrum communication demodulator in communication with a receiver code generator and with a digital demodulator;

said digital demodulator in communication with a Viterbi decoder;

said Viterbi decoder in communication with a receiver decoder;

said receiver decoder in communication with a DAC;

said DAC in communication with a low pass filter to pass the analog music signal in the approximate frequency band of 20 Hz to 20 kHz; and

said low pass filter passing analog music signal will be amplified for processing to a speaker headphone set to provide high quality music for listening by a single user wearing the headphones.

11. (New) An audio music digital wireless receiver for spread spectrum communication of an audio music signal to be received by a battery powered spread spectrum headphone receiver comprising:

a receiving antenna in communication with a spread spectrum communication demodulator;

Serial No.: 10/648,012  
Amdt. Dated: March 14, 2006

Attorney Docket No.: 73785-013

said spread spectrum communication demodulator in communication with a code generator configured to create a unique hop pattern for each individual user;  
said digital demodulator in communication with a Viterbi decoder;  
said Viterbi decoder in communication with a decoder;  
said decoder in communication with a DAC;  
said DAC in communication with a low pass filter to pass the analog music signal in the approximate frequency band of 20 Hz to 20kHz; and  
said low pass filter passing analog music signal will be amplified for processing to a speaker headphone set to provide high quality music for listening by a single user wearing the headphones.

12. (New) A wireless digital audio music system for spread spectrum communication of an audio music signal from the analog headphone jack connected to a battery powered spread spectrum transmitter and received by a battery powered spread spectrum headphone receiver comprising:

an analog headphone jack from an audio music source in communication with a battery powered digital transmitter;

said battery powered digital transmitter converts an audio music signal from said existing analog headphone jack to a digital signal using an ADC in communication with an encoder;

said encoder in communication with a channel encoder;

said channel encoder in communication with a digital modulator;

said digital modulator in communication with a spread spectrum communication modulator that utilizes a code generator to create a unique hop pattern for an individual user;

said spread spectrum communication modulator in communication with a transmit antenna that transmits at a radio frequency of approximately 2.4 GHz for receipt by a receiving antenna;

said receiving antenna in communication with a spread spectrum communication demodulator;

Serial No.: 10/648,012  
Amdt. Dated: March 14, 2006

Attorney Docket No.: 73785-013

a 2.4 GHz direct conversion receiver that includes a spread spectrum communication demodulator and a receiver code generator;

said spread spectrum communication demodulator in communication with said receiver code generator and with a digital demodulator;

said digital demodulator in communication with a channel decoder;

said channel decoder in communication with a receiver decoder;

said receiver decoder in communication with a DAC;

said DAC in communication with a low pass filter to pass the analog music signal in the approximate frequency band of 20 Hz to 20 kHz; and

said low pass filter passing analog music signal will be amplified for processing to a speaker headphone set to provide high quality music for listening by a single user wearing the headphones.

13. (New) An audio music digital wireless receiver for spread spectrum communication of an audio music signal, comprising:

a receiving antenna in communication with a 2.4 GHz direct conversion receiver, wherein the direct conversion receiver includes a spread spectrum communication demodulator in communication with a code generator, said code generator being configured to create a unique hop pattern for each individual user;

said digital demodulator in communication with a channel decoder;

said channel decoder in communication with a decoder;

said decoder in communication with a DAC;

said DAC in communication with a low pass filter to pass the analog music signal in the approximate frequency band of 20 Hz to 20kHz; and

said low pass filter passing analog music signal will be amplified for processing to a speaker headphone set to provide high quality music for listening by a single user wearing the headphones.

Serial No.: 10/648,012  
Amdt. Dated: March 14, 2006

Attorney Docket No.: 73785-013

**Amendments to the Drawings:**

The drawings were objected to as incorporating new matter because of the altered order of the filter in relation to other elements. Corrected drawings were required because of the altered order of the filter in Figs. 2 and 3. More particularly, with respect to Fig. 2, the low pass filter was shown between the ADC and encoder, thus differing from the drawings in the parent application. With respect to Fig. 3, the bandpass filter was shown in a different order from that shown in the parent.

In order to expedite matters, Applicant has deleted the low pass filter of Fig. 2 as well as the bandpass filter of Fig. 3. These filters are often included with analog-to-digital converters and demodulators such as those shown in Figs. 2 and 3.

Moreover, Applicant has specified in Fig. 3 that the channel decoder 66 is a Viterbi channel decoder. Also in Fig. 3, Applicant has specified that the receiver is a direct conversion receiver. Each of these elements was originally found in Applicant's parent specification.

**ATTACHMENTS: 1 ANNOTATED SHEET AND 2 REPLACEMENT SHEETS**

Serial No.: 10/648,012  
Amdt. Dated: March 14, 2006

Attorney Docket No.: 73785-013

### REMARKS

Applicant would like to thank Examiner Xu Mei and Examiner Andrew Graham for discussing the claims on January 26, 2006 at 2:00 p.m. EST.

Claims 1, 4, 6 and 7 remain pending in this application. These claims have been amended to further clarify the scope of the invention for the reasons set forth below. Moreover, new Claims 8-13 have been added with additional limitations discussed in the Examiner interview.

#### Rejection under 35 USC 132-New Matter

The specification was objected to under 35 USC 132 as allegedly incorporating new matter. More particularly, the specification was objected to based on a throughput rate "that may be as low as approximately 1.0 Mbps." Applicant's disclosure provided that the throughput may be approximately 1.4 Mbps. Accordingly, Applicant submits that the phrase objected to was not new matter. However, in order to further expedite prosecution, Applicant has deleted this language from the specification. Accordingly, Applicant requests that this objection be withdrawn.

#### Rejection under 35 USC 112, 1st paragraph

Claims 1 and 6 stand rejected under 35 USC 112, 1st paragraph, as allegedly failing to comply with the written description requirement. More particularly, the office action provided that the limitation "an ADC in communication with an encoder at a signal rate of less than approximately 1.0 Mbps" incorporated new matter because there was no support for this throughput rate between the ADC and encoder. Applicant has

Serial No.: 10/648,012  
Amdt. Dated: March 14, 2006

Attorney Docket No.: 73785-013

amended the cited claims to read -- an ADC in communication with an encoder--, deleting the reference to the signal rate. Accordingly, Applicant submits that this rejection has been overcome.

#### Rejections under 35 USC 103

Claims 1, 4, 6 and 7 were rejected under 35 USC 103 as allegedly being unpatentable over Alstatt (USPN 5771441) in view of Schotz et al (USPN 5946343) and further in view of Schotz (USPN 5491839).

Applicant respectfully submits that a *prima facie* case of obviousness has not been made since the references do not teach or suggest all claim limitations. Claims 1, 4 and 6 require a code generator that generates or modulates a "user code" that creates a unique hop pattern for each individual user. The present invention uses frequency hopping spread spectrum (FHSS) transmission technology with a unique pseudo-noise (PN) code that is long enough, and that has low cross-correlation properties so that the hop pattern is unique for each individual user. FHSS employs a data signal that is modulated with a narrowband carrier signal that "hops" in a random but predictable sequence from frequency to frequency as a function of time over a wide band of frequencies. The signal energy is spread in the time domain--as opposed to severing each bit into small pieces in the frequency domain. The FHSS technique reduces interference because a signal from a narrowband system may only affect the spread spectrum signal if both are transmitting at the same frequency at the same time. If synchronized properly, a single logical channel is maintained. With FHSS, the transmission frequencies are determined by the PN code. The receiver is set to the same hopping code and listens to the incoming signal at the right time and correct frequency.

Serial No.: 10/648,012  
Amdt. Dated: March 14, 2006

Attorney Docket No.: 73785-013

By contrast, Schotz uses "one of four different PN sequences." (See Schotz '343 at Col. 16:61 to Col. 17:2) These codes are assigned to specific devices for a single household--not individual users. As such, the Schotz code may be properly deemed a "device code" as opposed to a "user code" as in the present invention. There is no mention in Schotz that the PN code must support individual users operating within the same space. By contrast, the present invention addresses the interference between individual users [parent specification/page4/lines16-22] and each PN code and its hopping sequence is generated to address the needs of individual users. (See e.g., paras. 0009 and 0011 of the present disclosure.)

While Applicant submits that the references did not teach or suggest all claim limitations as presented, Applicant has amended Claims 1, 4 and 6 to recite "a code generator" that creates "a unique hop pattern for each individual user." This amendment is made to further clarify the scope of the invention. Moreover, this limitation has been added to Claim 7, and all new Claims 8-13 further include this limitation. Accordingly, Applicant submits that the claims clearly state that this code generator is used to create a unique hop pattern for each individual user, a limitation not taught or suggested by the prior art references. Accordingly, Applicant respectfully submits that this rejection has been overcome.

Moreover, a *prima facie* case of obviousness was not made because the references do not teach or suggest the limitation directed to an analog battery-powered digital transmitter. The office action provides that the combination of Alstatt and Schotz's '343 Patent teaches a battery powered digital transmitter. Applicant respectfully submits that a *prima facie* case of obviousness has not been made. More particularly, the combination

Serial No.: 10/648,012  
Amdt. Dated: March 14, 2006

Attorney Docket No.: 73785-013

of the battery-powered analog transmitter of Alstatt and the wall-powered digital transmitter of Schotz '343 would render Alstatt unsatisfactory for its intended purpose. Alstatt would suffer from a significantly reduced play time due to the power consumption of Schotz's numerous integrated circuits. Moreover, the Alstatt headphones for his portable device would be rendered too large because of the size of the integrated circuits used in Schotz.

For the same reasons of reduced play time and unwieldy headphones, the combination of Alstatt and Schotz would not provide a reasonable expectation of success. Accordingly, Applicant respectfully submits that a *prima facie* case of obviousness has not been made in this respect as well.

New limitations have been added to the new Claims 8-13, as discussed in Applicant's Examiner interview. New Claims 8 and 9 have been added to recite a channel decoder that permits soft-decision decoding. New Claims 10-11 have been added to recite a channel decoder that is a Viterbi decoder. (For further clarification, Claim 10, directed to the system, includes a limitation that the channel encoder is configured to send encoded symbols that are compatible with a Viterbi decoder). The specification has also been amended to recite that the channel decoder may be a Viterbi decoder. This material was present in the parent application to which the present application claims priority. [See page 4, line 27 of the parent application]

The Viterbi decoder--or a channel decoder that permits soft-decision decoding--is not taught or suggested by the prior art references. Schotz incorporates a 1/2 rate extended Golay block coding scheme. (Col. 9:19-26) Schotz's block coding scheme differs significantly from the coding scheme of the present claims. More particularly,



Serial No.: 10/648,012  
Amdt. Dated: March 14, 2006

Attorney Docket No.: 73785-013

soft-decision coding may be used to prevent a greater band of interference than the Golay block coding scheme.

While the Viterbi channel encoding/decoding scheme permits hard decision coding as found in Schotz, it is the ability of this Viterbi scheme to further permit soft-decision coding that permits the Viterbi scheme to suppress a broader range of interference from other users. The Viterbi channel encoding/decoding scheme prevents interference (or jamming) from other system users. This interference can be represented as follower (or repeater) interference.

The follower (or repeater) jammer transmits frequency-hopped narrowband interference using the same hop sequence as the communicator, where the communicator is the primary user. This is equivalent to at least one additional system user in operation within the same space (or range) of a primary user. The follower (or repeater) jammers' output--resulting from use by other system users--must arrive at the primary user's frequency-hopping receiver hop frequency band space and dwell there long enough to cause interference before hopping to the next hop frequency band. The partial band jammer that is referenced in Schotz's design is defined as a transmitter (non-hopping type) that transmits its available power into a limited bandwidth which is smaller than the spread spectrum bandwidth. (See Schotz '343, para. 0016, lines 1-5)

Contrary to hard-decision decoding, soft-decision decoding includes additional information symbols to determining the reliability of the symbols being decoded. Included in the additional information symbols of the present invention is jammer state information (JSI). JSI includes information regarding the potential jamming threat, including the hop rate, dwell time, bandwidth, and so on, that would cause interference in

Serial No.: 10/648,012  
Amdt. Dated: March 14, 2006

Attorney Docket No.: 73785-013

the system of the present disclosure. The JSI permits the receiver headphones to know if other system users are in the area, and if so, then the Viterbi decoder assigns less weight to the symbols that may be jammed so that it makes the a better estimate of the transmitted code sequence.

The Schotz design uses hard-decision decoding (see e.g., reference SRT241203) that does not incorporate JSI, as required with soft-decision decoding. In addition, Schotz states that forward error correction (see e.g., SRT241203) can be eliminated by frequency hopping is used in his design. (See Schotz para. 0016, lines 5-10)

Repeater jamming interference occurs when other system users are within relatively close range to one another. In accordance with the present invention, a repeater jammer transmits frequency-hopped narrow band interference using the same hop rate and dwell time as the primary user. This is the case for one or more other system users, because the same hop rate and dwell time is used for all system users, but each has a different PN code sequence. So, the repeater jammer (represented by other system users) may transmit an interference signal that may hop along with the primary system user to create interference in the receiver headphones of the primary system user. Schotz does not suppress this type of interference.

Schotz provides states that his system adds "control information" so there is no "need for independent stereos" in the same space. (See Schotz Abstract). Accordingly, Schotz does not design his system to function with multiple users (i.e., multiple stereos) in the same space. In fact, he teaches away from the use of independent stereos.

Serial No.: 10/648,012  
Amdt. Dated: March 14, 2006

Attorney Docket No.: 73785-013

Schotz states the forward error correction is not needed (See Schotz at Column16:1-10). Further, the hard-decision decoder Schotz uses does not apply additional confidence symbols (like JSI) to maximize accurate decoding.

New Claims 12 and 13 have also been added to recite a 2.4 GHz direct conversion receiver. These receivers are compatible with systems incorporating frequency hopping spread spectrum (FHSS) transmission technology. Applicant respectfully submits that the prior art does not teach or suggest a direct conversion receiver. Schotz '343 incorporates a superheterodyne receiver that uses quadrature phase-shift keying as a modulation technique. This superheterodyne receiver incorporates filtering, oscillator and frequency synthesis components that are not needed when a direct conversion receiver is used. Moreover, at the time of Applicant's invention, the QPSK modulation technique was not compatible with modulation using frequency shift keying (FSK), so Schotz does not suggest a direct conversion receiver.

#### Clarifying Amendments

Minor amendments have further been made to the claims in order to correct typographical errors. More particularly, Claim 4 has been amended to recite that the method comprises the steps of various elements, with steps being plural instead of singular. Claim 4 has also been amended to recite, as part of the method "*communicating*" said analog music signal instead of "communication". Further, Claim 4 has been amended to delete reference to a distance of reception. The preambles of Claims 6 and 7 have been amended to delete reference, respectively, to "an analog headphone jack connected to a battery powered spread spectrum transmitter" and "to be

Serial No.: 10/648,012  
Amdt. Dated: March 14, 2006

Attorney Docket No.: 73785-013

received by a battery powered spread spectrum headphone receiver." A semicolon has been added after the first element of Claim 7 directed to "a receiving antenna in communication with a spread spectrum headphone receiver."

Claim 6 has also been amended to recite that the battery powered digital transmitter is *configured to convert* an analog audio music signal, as opposed to "converts" an analog audio music signal.

#### Conclusion

Applicant respectfully submits that the claims are in condition for allowance. A notice of allowance is respectfully requested.

While Applicant does not believe any fees are necessary since this response is submitted within the two-month window after the December 30, 2005 office action. However, if any such fees are deemed necessary, please charge any additional fees which may be required, or credit overpayment to Deposit Account No. 50-1946, referencing number 073785-0013.

Respectfully submitted,

March 14, 2006  
Date

Daphne L. Burton  
Daphne L. Burton  
Registration No. 45,323

MCDERMOTT WILL & EMERY, LLP  
2049 Century Park East, 34th Floor  
Los Angeles, CA 90067  
Telephone: (310) 277-4110  
Facsimile: (310) 277-4730

ANNOTATED SHEET

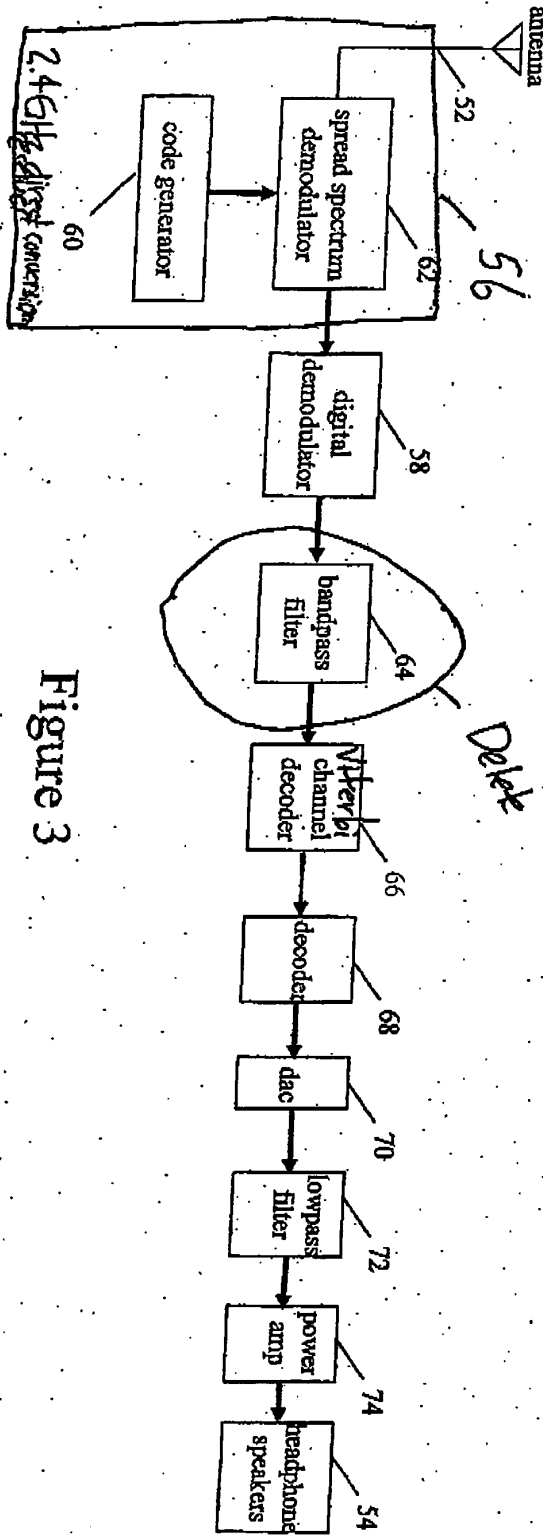

Figure 3

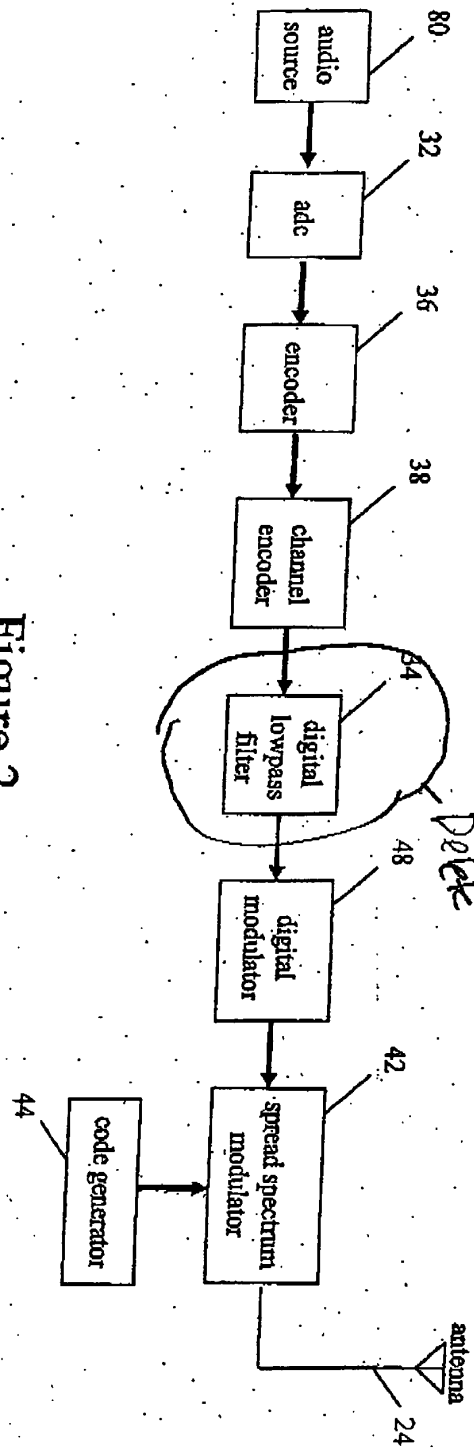

Figure 2

BEST AVAILABLE COPY

ANNOTATED SHEET

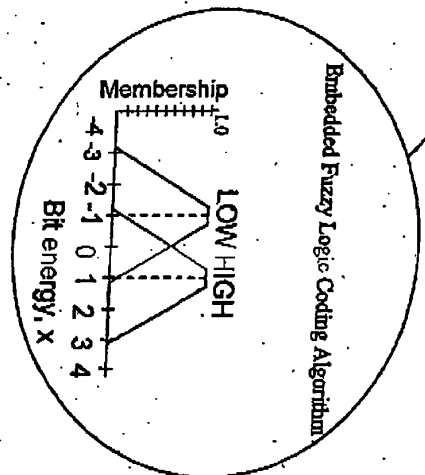
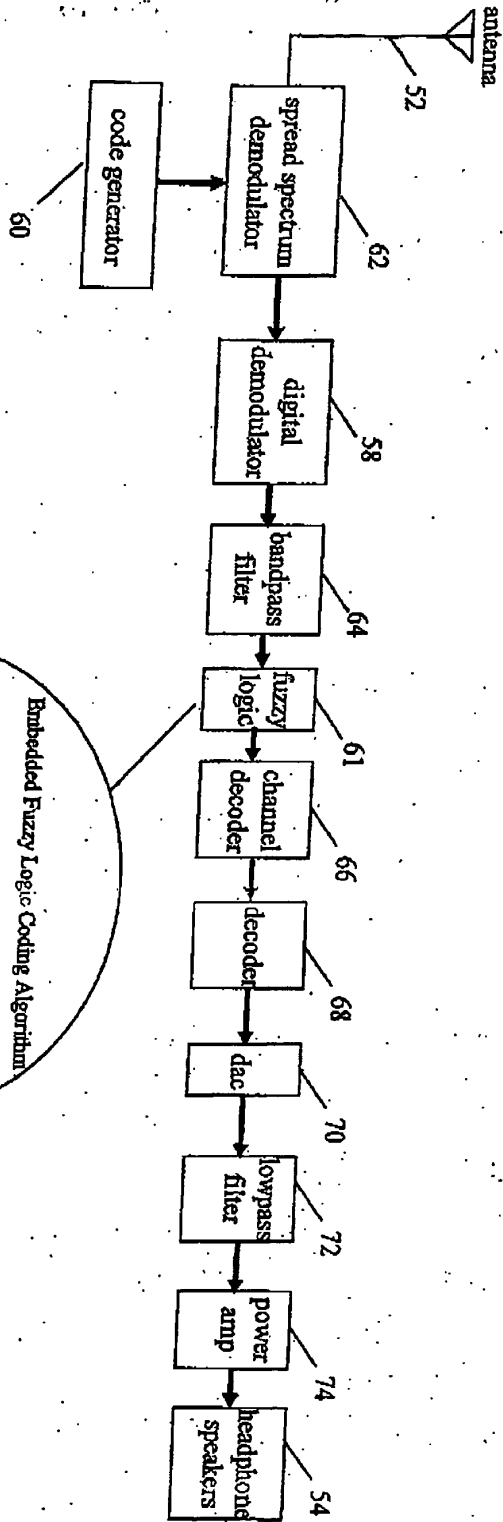

Figure 4

ST AVAILABLE

REPLACEMENT SHEET

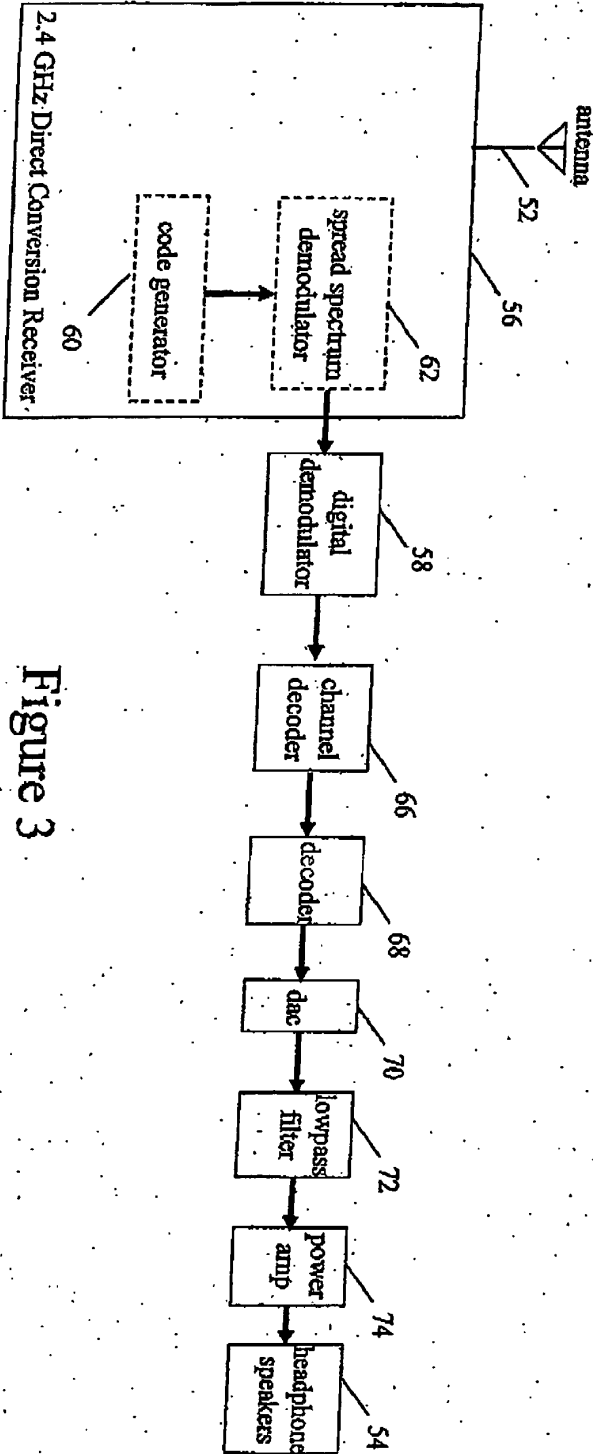

Figure 3

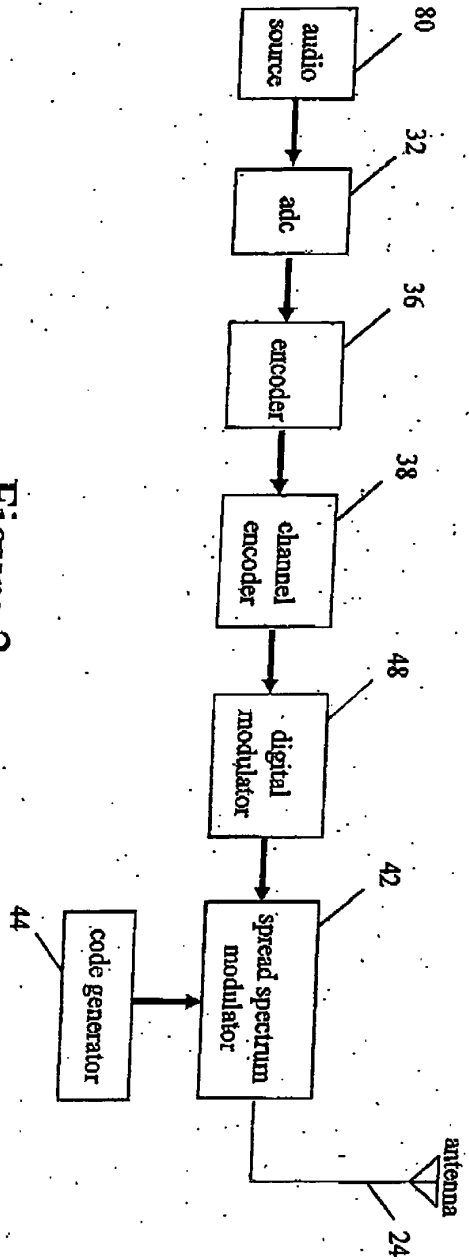

Figure 2

REPLACEMENT SHEET

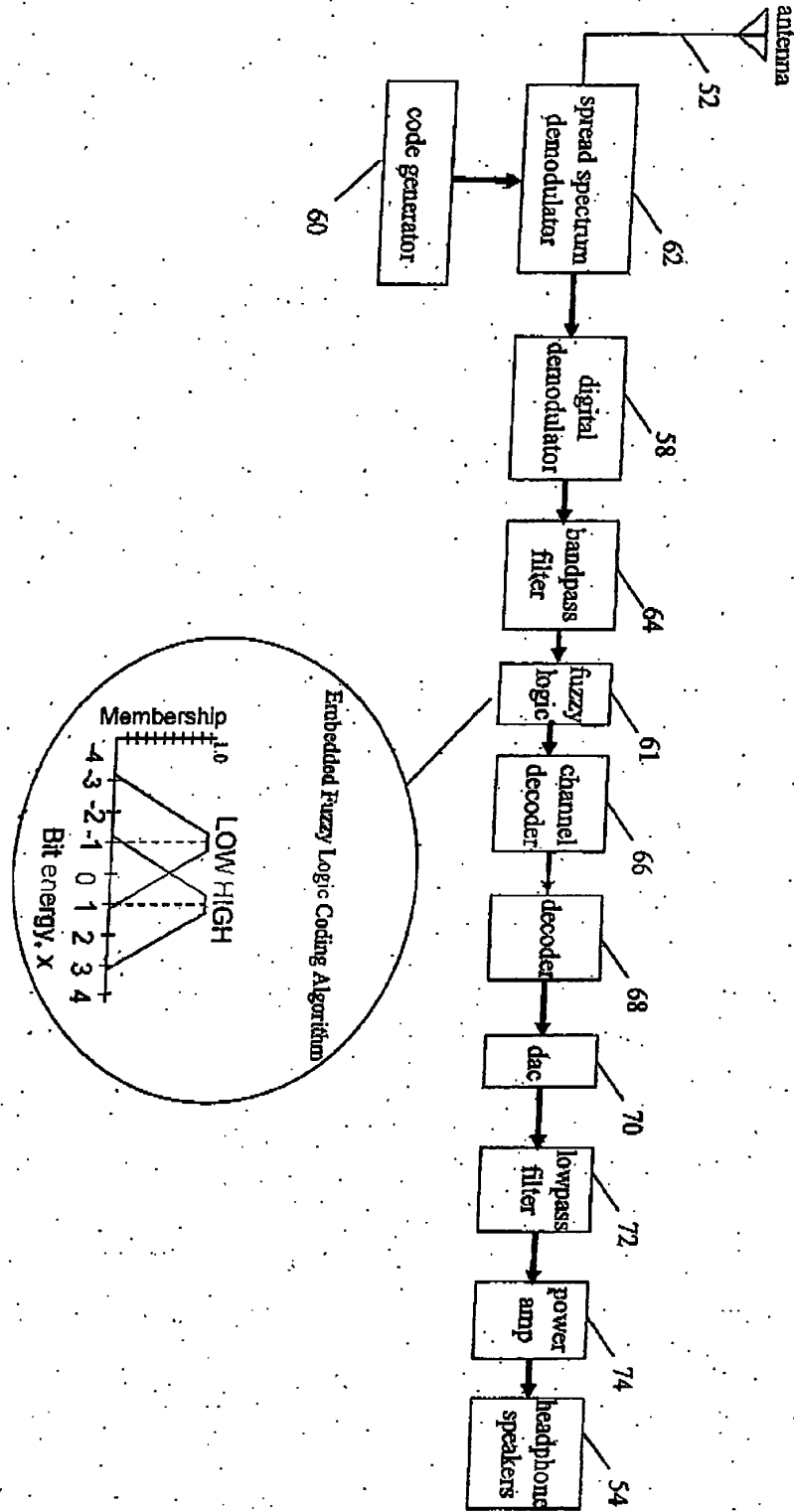

Figure 4



RECEIVED  
CENTRAL FAX CENTER

MAR 14 2006

<b>REQUEST FOR CONTINUED EXAMINATION (RCE) TRANSMITTAL</b>  <small>Subsection (b) of 35 U.S.C. § 132, effective on May 29, 2000, provides for continued examination of an utility or plant application filed on or after June 8, 1995. See the American Inventors Protection Act of 1999 (AIPA).</small>	<i>Application Number</i>	10/648,012
	<i>Filing Date</i>	August 26, 2003
	<i>First Named Inventor</i>	C. Earl Woolfork
	<i>Group Art Unit</i>	2644
	<i>Examiner Name</i>	A. Graham
	<i>Attorney Docket Number</i>	73785-013

This is a Request for Continued Examination (RCE) under 37 C.F.R. § 1.114 of the above-identified application  
NOTE: 37 C.F.R. § 1.114 is effective on May 29, 2000. If the above-identified application was filed prior to May 29, 2000, applicant may wish to consider filing a continued prosecution application (CPA) under 37 C.F.R. § 1.53 (4) (PTO/SB/29) instead of a RCE to be eligible for the patent term adjustment provisions of the AIPA. See Changes to Application Examination and Provisional Application Practice, Interim Rule, 65 Fed. Reg. 14865 (Mar. 20, 2000), 1233 Off. Gaz. Pat. Office 47 (Apr. 11, 2000), which established RCE practice.

1. **Submission required under 37 C.F.R. § 1.114**

a.  Previously submitted

i.  Consider the amendments/reply under 37 C.F.R. § 1.116 previously filed on:

ii.  Consider the arguments in the Appeal Brief or Reply Brief previously filed on

iii.  Other

b.  Enclosed

i.  Amendment/Reply as filed on March 13, 2006 (previously submitted on February 16, 2005)

ii.  Affidavit(s)/Declaration(s)

iii.  Information Disclosure Statement (IDS)

iv.  Other

2. Miscellaneous

a.  Suspension of action of the above-identified application is requested under 37 C.F.R. § 1.1.03(c) for a period of \_\_\_ months. (Period of suspension shall not exceed 3 months; Fee under 37 C.F.R. § 1.17(f) required)

b.  Other

3. Fees The RCE fee under 37 C.F.R. § 1.17(e) is required by 37 C.F.R. § 1.114 when the RCE is filed.

a.  The Director is hereby authorized to charge the following fees, or credit any overpayments, to Deposit Account No. 50-1946

i.  RCE fee required under 37 C.F.R. § 1.17(e) \$395.00

ii.  Extension of time fee (37 C.F.R. §§ 1.136 and 1.17)

iii.  Other

b.  Check in the amount of \$\_\_\_ enclosed

c.  Payment by credit card (Form PTO-2038 enclosed)

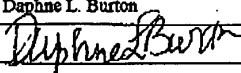
SIGNATURE OF APPLICANT, ATTORNEY, OR AGENT REQUIRED			
<i>Name (Print/Type)</i>	Daphne L. Burton	<i>Registration No. (Attorney/Agent)</i>	45,323
<i>Signature</i>		<i>Date</i>	March 14, 2006

**CERTIFICATE OF FACSIMILE TRANSMISSION UNDER 37 C.F.R. § 1.6(d)**

I hereby certify that this correspondence is being transmitted via facsimile to 571-273-8300 under 37 CFR 1.6(d) to Mail Stop: RCE on the date below.

<i>Name (Print/Type)</i>	Anita Chou	<i>Signature</i>		<i>Date</i>	March 14, 2006
--------------------------	------------	------------------	---	-------------	----------------

LAS99 1446854-1.073785.0013

**PATENT APPLICATION FEE DETERMINATION RECORD**  
Effective January 1, 2003

Application or Docket Number

10/649012

**CLAIMS AS FILED - PART I**

	(Column 1)	(Column 2)
TOTAL CLAIMS	5	
FOR	NUMBER FILED	NUMBER EXTRA
TOTAL CHARGEABLE CLAIMS	5 minus 20 =	0
INDEPENDENT CLAIMS	3 minus 3 =	0
MULTIPLE DEPENDENT CLAIM PRESENT <input type="checkbox"/>		

\* If the difference in column 1 is less than zero, enter "0" in column 2

SMALL ENTITY TYPE  OR

OTHER THAN SMALL ENTITY

RATE	FEE	OR	RATE	FEE
BASIC FEE	375.00	OR	BASIC FEE	750.00
X\$ 9=		OR	X\$18=	
X42=		OR	X84=	
+140=		OR	+280=	
TOTAL	375	OR	TOTAL	

**CLAIMS AS AMENDED - PART II**

10/25/05

	(Column 1)	(Column 2)	(Column 3)
AMENDMENT A	CLAIMS REMAINING AFTER AMENDMENT	HIGHEST NUMBER PREVIOUSLY PAID FOR	PRESENT EXTRA
Total	5	20	0
Independent	3	3	0
FIRST PRESENTATION OF MULTIPLE DEPENDENT CLAIM <input type="checkbox"/>			

SMALL ENTITY OR OTHER THAN SMALL ENTITY

RATE	ADDITIONAL FEE	OR	RATE	ADDITIONAL FEE
X\$ 9=		OR	X\$18=	
X42=		OR	X84=	
+140=		OR	+280=	
TOTAL ADDIT. FEE		OR	TOTAL ADDIT. FEE	

2/16/06

	(Column 1)	(Column 2)	(Column 3)
AMENDMENT B	CLAIMS REMAINING AFTER AMENDMENT	HIGHEST NUMBER PREVIOUSLY PAID FOR	PRESENT EXTRA
Total	10	20	0
Independent	10	4	6
FIRST PRESENTATION OF MULTIPLE DEPENDENT CLAIM <input type="checkbox"/>			

RATE	ADDITIONAL FEE	OR	RATE	ADDITIONAL FEE
X\$ 9=		OR	X\$18=	
X42=	600	OR	X84=	
+140=		OR	+280=	
TOTAL ADDIT. FEE	600	OR	TOTAL ADDIT. FEE	

RCF  
3/14/06

	(Column 1)	(Column 2)	(Column 3)
AMENDMENT C	CLAIMS REMAINING AFTER AMENDMENT	HIGHEST NUMBER PREVIOUSLY PAID FOR	PRESENT EXTRA
Total	10	20	0
Independent	10	10	0
FIRST PRESENTATION OF MULTIPLE DEPENDENT CLAIM <input type="checkbox"/>			

RATE	ADDITIONAL FEE	OR	RATE	ADDITIONAL FEE
X\$ 9=		OR	X\$18=	
X42=		OR	X84=	
+140=		OR	+280=	
TOTAL ADDIT. FEE		OR	TOTAL ADDIT. FEE	

- \* If the entry in column 1 is less than the entry in column 2, enter "0" in column 3.
- \*\* If the "Highest Number Previously Paid For" IN THIS SPACE is less than 20, enter "20."
- \*\*\* If the "Highest Number Previously Paid For" IN THIS SPACE is less than 4, enter "4."
- \*\*\*\* If the "Highest Number Previously Paid For" (Total or Independent) is the highest number found in the appropriate box in column 1.

United States Patent and Trademark Office  
- Sales Receipt -

03/22/2006 SCARMICH 00000001 501946 10648012

01 FC:1801 790.00 DA

*AW*

**PATENT**



**IN THE UNITED STATES PATENT AND TRADEMARK OFFICE**

Inventor Application of:  
C. Earl Woolfork

Group Art Unit: 2644

Examiner: Andrew Graham

Serial No.: 10/648,012

Filed: August 26, 2003

For: WIRELESS DIGITAL AUDIO  
MUSIC SYSTEM

**CERTIFICATE OF MAILING (37 C.F.R. § 1.8(a))**

I hereby certify that this correspondence is being deposited with the United States Postal Service as First Class Mail under 37 CFR 1.8(a) in an envelope addressed to, Mail Stop: Amendment, Commissioner for Patents, P.O. Box 1450, Alexandria, VA 22313-1450 on March 13, 2006.

*Anita Chou*  
Anita Chou

Mail Stop Amendment  
Commissioner for Patents  
P.O. Box 1450  
Alexandria, VA 22313-1450

**RESPONSE TO NOTICE OF NON-COMPLIANT AMENDMENT MAILED**  
**MARCH 7, 2006**  
**(CORRECTED RESPONSE TO OFFICE ACTION MAILED FEBRUARY 16, 2005)**

Sir:

In response to the Notice of Non-Complaint Amendment 37 CFR §1.121 mailed on March 7, 2005, Applicant re-files herewith the response to the office action mailed to the PTO on February 16, 2005. This response corrects the previously filed response by deleting the brackets in the "New" claims. Applicant timely files this response within one month of the mailing date of the notice.

**Amendments to the specification** begin on page 2 of this paper.

**Amendments to the claims** are reflected in the listing of claims which begins on page 3 of this paper.

**Amendments to the drawings** begin on page 12.

**Remarks** begin on page 13 of this paper.

**Amendments to the Specification:**

Please amend the specification as follows:

On page 6, line 10, (or paragraph [0009], line 12) please delete the following sentence:

"This digital signal has a throughput of approximately 1.4 Mbps that may be as low as approximately 1.0 Mbps."

On page 6, line 11, please delete the number "34" at the end of the sentence so that this sentence will read: "After digital conversion, the digital signal may be processed by a digital low pass filter."

At para. 0010, line 6, please delete the number "64" at the end of the sentence so that this sentence will read: "The transmitted signal from transmit antenna 24 may be received by receiving antenna 52 and communicated to a wideband bandpass filter (BPF)."

At paragraph [0016], line 1, please replace the first sentence with the following:

--The channel decoder 66 may be a Viterbi decoder. A channel decoder 66 may be in communication with the bandpass filter. --

At paragraph [0010], line 6, please add the following sentences at the beginning of this paragraph: --A digital signal may be received at antenna receiving antenna 52 and communicated to, e.g., a wideband bandpass filter. The received spread spectrum signal may then be communicated to a 2.4 GHz direct conversion receiver 56. A frequency shift keying (FSK) modulation/detection technique could be used given a frequency hopping spread spectrum (FHSS) system choice. The direct conversion receiver 56 may provide a means to convert the received signal while using timing and synchronization to capture the correct bit sequence embedded in the received spread spectrum signal. --

**Amendments to the Claims:**

Please amend the claims as follows:

1. (Currently amended) A wireless digital audio music system for spread spectrum communication of an audio music signal from the analog headphone jack connected to a battery powered spread spectrum transmitter and received by a battery powered spread spectrum headphone receiver comprising:

an analog headphone jack from an analog audio music source in communication with a battery powered digital transmitter;

said battery powered digital transmitter converts an analog audio music signal from said existing analog headphone jack to a digital signal using an ADC in communication with an encoder [at a signal rate of less than approximately 1.0 Mbps];

said encoder in communication with a channel encoder;

said channel encoder in communication with [a digital low pass filter;

said digital low pass filter in communication with] a digital modulator;

said digital modulator in communication with a spread spectrum communication modulator that utilizes a code generator to create [user code] a unique hop pattern for each individual user;

said spread spectrum communication modulator in communication with a transmit antenna that transmits at a radio frequency of approximately 2.4 GHz for receipt by a receiving antenna;

said receiving antenna in communication with a spread spectrum communication demodulator;

said spread spectrum communication demodulator in communication with a receiver code generator and with a digital demodulator;

said digital demodulator in communication with [a wide bandpass filter;

said wide bandpass filter in communication with] a channel decoder;

said channel decoder in communication with a receiver decoder;

said receiver decoder in communication with a DAC;

said DAC in communication with a low pass filter to pass the analog music signal in the approximate frequency band of 20 Hz to 20 kHz; and

said low pass filter passing analog music signal will be amplified for processing to a speaker headphone set to provide high quality music for listening by a single user wearing the headphones.

2. (Canceled).

3. (Canceled).

4. (Currently amended) A method for battery powered wireless communication transmission and reception of high fidelity audio music between a battery operated digital transmitter and a battery operated digital receiver headphone comprising the steps of:

connecting the plug attached to said battery operated digital transmitter to the existing analog headphone jack of an audio music source;

converting a music audio signal to a digital communication signal using an ADC in communication with an encoder;

encoding the communication signal using channel encoding;

[digital low pass filtering the communication signal;]

modulating the digital communication signal using a digital modulator;

creating a spread spectrum signal using a code generator to modulate a [unique user code] unique hop pattern for each individual user;

transmitting said spread spectrum signal at a radio frequency of approximately 2.4 GHz [at a power level for reception at a distance up to approximately 10 feet from said battery operated transmitter];

receiving said spread spectrum signal at said battery operated receiver headphones;

demodulating said spread spectrum signal;

demodulating said digital communication signal;

[bandpass filtering said digital communication signal;]

channel decoding of said digital communication signal;

converting said digital communication signal back to said analog music audio signal using a decoder in communication with a DAC; and

[communication] communicating said analog music audio signal to a headphone speaker within the headphone receiver.

5. (Canceled)

6. (Currently amended) An audio music digital wireless transmitter for spread spectrum communication of an audio music signal [from an analog headphone jack connected to a battery powered spread spectrum transmitter], comprising:

an analog headphone jack from an audio music source in communication with a battery powered digital transmitter;

said battery powered digital transmitter [converts] being configured to convert an analog audio music signal from said existing analog headphone jack to a digital signal using an ADC in communication with an encoder [at a signal rate of less than approximately 1.0 Mbps];

said encoder in communication with a channel encoder;

said channel encoder in communication with [a digital low pass filter;

said digital low pass filter in communication with] a digital modulator;

said digital modulator in communication with a spread spectrum communication modulator that utilizes a code generator to create [user code] a unique hop pattern for each individual user; and

said spread spectrum communication modulator in communication with a transmit antenna that transmits at a radio frequency of approximately 2.4 GHz for receipt by a receiving antenna.

7. (Currently amended) An audio music digital wireless receiver for spread spectrum communication of an audio music signal [to be received by a battery powered spread spectrum receiver], comprising:

a receiving antenna in communication with a spread spectrum communication demodulator;

said spread spectrum communication demodulator in communication with a code generator configured to create a unique hop pattern for each individual user;



said digital demodulator in communication with [a wide bandpass filter;  
said wide bandpass filter in communication with] a channel decoder;  
said channel decoder in communication with a decoder;  
said decoder in communication with a DAC;  
said DAC in communication with a low pass filter to pass the analog music signal  
in the approximate frequency band of 20 Hz to 20kHz; and  
said low pass filter passing analog music signal will be amplified for processing  
to a speaker headphone set to provide high quality music for listening by a single user  
wearing the headphones.

8. (New) A wireless digital audio music system for spread spectrum  
communication of an audio music signal from the analog headphone jack connected to a  
battery powered spread spectrum transmitter and received by a battery powered spread  
spectrum headphone receiver comprising:

an analog headphone jack from an audio music source in communication with a  
battery powered digital transmitter;

said battery powered digital transmitter converts an analog audio music signal  
from said existing analog headphone jack to a digital signal using an ADC in  
communication with an encoder;

said encoder in communication with a channel encoder;

said channel encoder in communication with a digital modulator;

said digital modulator in communication with a spread spectrum communication  
modulator that utilizes a code generator to create a unique hop pattern for each individual  
user;

said spread spectrum communication modulator in communication with a transmit  
antenna that transmits at a radio frequency of approximately 2.4 GHz for receipt by a  
receiving antenna;

said receiving antenna in communication with a spread spectrum communication  
demodulator;

said spread spectrum communication demodulator in communication with a  
receiver code generator and with a digital demodulator;

said digital demodulator in communication with a channel decoder that is configured to perform soft-decision decoding;

said channel decoder in communication with a receiver decoder;

said receiver decoder in communication with a DAC;

said DAC in communication with a low pass filter to pass the analog music signal in the approximate frequency band of 20 Hz to 20 kHz; and

said low pass filter passing analog music signal will be amplified for processing to a speaker headphone set to provide high quality music for listening by a single user wearing the headphones.

9. (New) An audio music digital wireless receiver for spread spectrum communication of an audio music signal, comprising:

a receiving antenna in communication with a spread spectrum communication demodulator;

said spread spectrum communication demodulator in communication with a code generator configured to create a unique hop pattern for each individual user;

said digital demodulator in communication with a channel decoder that is configured to perform soft-decision decoding;

said channel decoder in communication with a decoder;

said decoder in communication with a DAC;

said DAC in communication with a low pass filter to pass the analog music signal in the approximate frequency band of 20 Hz to 20kHz; and

said low pass filter passing analog music signal will be amplified for processing to a speaker headphone set to provide high quality music for listening by a single user wearing the headphones.

10. (New) A wireless digital audio music system for spread spectrum communication of an audio music signal from the analog headphone jack connected to a battery powered spread spectrum transmitter and received by a battery powered spread spectrum headphone receiver comprising:

an analog headphone jack from an audio music source in communication with a battery powered digital transmitter;

said battery powered digital transmitter converts an analog audio music signal from said existing analog headphone jack to a digital signal using an ADC in communication with an encoder;

said encoder in communication with a channel encoder that is configured to send encoded symbols that are compatible with a Viterbi decoder;

said channel encoder in communication with a digital modulator;

said digital modulator in communication with a spread spectrum communication modulator that utilizes a code generator to create a unique hop pattern for each individual user;

said spread spectrum communication modulator in communication with a transmit antenna that transmits at a radio frequency of approximately 2.4 GHz for receipt by a receiving antenna;

said receiving antenna in communication with a spread spectrum communication demodulator;

said spread spectrum communication demodulator in communication with a receiver code generator and with a digital demodulator;

said digital demodulator in communication with a Viterbi decoder;

said Viterbi decoder in communication with a receiver decoder;

said receiver decoder in communication with a DAC;

said DAC in communication with a low pass filter to pass the analog music signal in the approximate frequency band of 20 Hz to 20 kHz; and

said low pass filter passing analog music signal will be amplified for processing to a speaker headphone set to provide high quality music for listening by a single user wearing the headphones.

11. (New) An audio music digital wireless receiver for spread spectrum communication of an audio music signal to be received by a battery powered spread spectrum headphone receiver comprising:

a receiving antenna in communication with a spread spectrum communication demodulator;

said spread spectrum communication demodulator in communication with a code generator configured to create a unique hop pattern for each individual user;

said digital demodulator in communication with a Viterbi decoder;

said Viterbi decoder in communication with a decoder;

said decoder in communication with a DAC;

said DAC in communication with a low pass filter to pass the analog music signal in the approximate frequency band of 20 Hz to 20kHz; and

said low pass filter passing analog music signal will be amplified for processing to a speaker headphone set to provide high quality music for listening by a single user wearing the headphones.

12. (New) A wireless digital audio music system for spread spectrum communication of an audio music signal from the analog headphone jack connected to a battery powered spread spectrum transmitter and received by a battery powered spread spectrum headphone receiver comprising:

an analog headphone jack from an audio music source in communication with a battery powered digital transmitter;

said battery powered digital transmitter converts an audio music signal from said existing analog headphone jack to a digital signal using an ADC in communication with an encoder;

said encoder in communication with a channel encoder;

said channel encoder in communication with a digital modulator;

said digital modulator in communication with a spread spectrum communication modulator that utilizes a code generator to create a unique hop pattern for an individual user;

said spread spectrum communication modulator in communication with a transmit antenna that transmits at a radio frequency of approximately 2.4 GHz for receipt by a receiving antenna;

said receiving antenna in communication with a spread spectrum communication demodulator;

a 2.4 GHz direct conversion receiver that includes a spread spectrum communication demodulator and a receiver code generator;

said spread spectrum communication demodulator in communication with said receiver code generator and with a digital demodulator;

said digital demodulator in communication with a channel decoder;

said channel decoder in communication with a receiver decoder;

said receiver decoder in communication with a DAC;

said DAC in communication with a low pass filter to pass the analog music signal in the approximate frequency band of 20 Hz to 20 kHz; and

said low pass filter passing analog music signal will be amplified for processing to a speaker headphone set to provide high quality music for listening by a single user wearing the headphones.

13. (New) An audio music digital wireless receiver for spread spectrum communication of an audio music signal, comprising:

a receiving antenna in communication with a 2.4 GHz direct conversion receiver, wherein the direct conversion receiver includes a spread spectrum communication demodulator in communication with a code generator, said code generator being configured to create a unique hop pattern for each individual user;

said digital demodulator in communication with a channel decoder;

said channel decoder in communication with a decoder;

said decoder in communication with a DAC;

said DAC in communication with a low pass filter to pass the analog music signal in the approximate frequency band of 20 Hz to 20kHz; and

said low pass filter passing analog music signal will be amplified for processing to a speaker headphone set to provide high quality music for listening by a single user wearing the headphones.

**Amendments to the Drawings:**

The drawings were objected to as incorporating new matter because of the altered order of the filter in relation to other elements. Corrected drawings were required because of the altered order of the filter in Figs. 2 and 3. More particularly, with respect to Fig. 2, the low pass filter was shown between the ADC and encoder, thus differing from the drawings in the parent application. With respect to Fig. 3, the bandpass filter was shown in a different order from that shown in the parent.

In order to expedite matters, Applicant has deleted the low pass filter of Fig. 2 as well as the bandpass filter of Fig. 3. These filters are often included with analog-to-digital converters and demodulators such as those shown in Figs. 2 and 3.

Moreover, Applicant has specified in Fig. 3 that the channel decoder 66 is a Viterbi channel decoder. Also in Fig. 3, Applicant has specified that the receiver is a direct conversion receiver. Each of these elements was originally found in Applicant's parent specification.

**ATTACHMENTS: 1 ANNOTATED SHEET AND 2 REPLACEMENT SHEETS**

### **REMARKS**

Applicant would like to thank Examiner Xu Mei and Examiner Andrew Graham for discussing the claims on January 26, 2006 at 2:00 p.m. EST.

Claims 1, 4, 6 and 7 remain pending in this application. These claims have been amended to further clarify the scope of the invention for the reasons set forth below. Moreover, new Claims 8-13 have been added with additional limitations discussed in the Examiner interview.

#### **Rejection under 35 USC 132-New Matter**

The specification was objected to under 35 USC 132 as allegedly incorporating new matter. More particularly, the specification was objected to based on a throughput rate "that may be as low as approximately 1.0 Mbps." Applicant's disclosure provided that the throughput may be approximately 1.4 Mbps. Accordingly, Applicant submits that the phrase objected to was not new matter. However, in order to further expedite prosecution, Applicant has deleted this language from the specification. Accordingly, Applicant requests that this objection be withdrawn.

#### **Rejection under 35 USC 112, 1st paragraph**

Claims 1 and 6 stand rejected under 35 USC 112, 1st paragraph, as allegedly failing to comply with the written description requirement. More particularly, the office action provided that the limitation "an ADC in communication with an encoder at a signal rate of less than approximately 1.0 Mbps" incorporated new matter because there was no support for this throughput rate between the ADC and encoder. Applicant has

amended the cited claims to read -- an ADC in communication with an encoder--, deleting the reference to the signal rate. Accordingly, Applicant submits that this rejection has been overcome.

### **Rejections under 35 USC 103**

Claims 1, 4, 6 and 7 were rejected under 35 USC 103 as allegedly being unpatentable over Alstatt (USPN 5771441) in view of Schotz et al (USPN 5946343) and further in view of Schotz (USPN 5491839).

Applicant respectfully submits that a *prima facie* case of obviousness has not been made since the references do not teach or suggest all claim limitations. Claims 1, 4 and 6 require a code generator that generates or modulates a "user code" that creates a unique hop pattern for each individual user. The present invention uses frequency hopping spread spectrum (FHSS) transmission technology with a unique pseudo-noise (PN) code that is long enough, and that has low cross-correlation properties so that the hop pattern is unique for each individual user. FHSS employs a data signal that is modulated with a narrowband carrier signal that "hops" in a random but predictable sequence from frequency to frequency as a function of time over a wide band of frequencies. The signal energy is spread in the time domain--as opposed to severing each bit into small pieces in the frequency domain. The FHSS technique reduces interference because a signal from a narrowband system may only affect the spread spectrum signal if both are transmitting at the same frequency at the same time. If synchronized properly, a single logical channel is maintained. With FHSS, the transmission frequencies are determined by the PN code. The receiver is set to the same hopping code and listens to the incoming signal at the right time and correct frequency.



By contrast, Schotz uses "one of four different PN sequences." (See Schotz '343 at Col. 16:61 to Col. 17:2) These codes are assigned to specific devices for a single household--not individual users. As such, the Schotz code may be properly deemed a "device code" as opposed to a "user code" as in the present invention. There is no mention in Schotz that the PN code must support individual users operating within the same space. By contrast, the present invention addresses the interference between individual users [parent specification/page4/lines16-22] and each PN code and its hopping sequence is generated to address the needs of individual users. (See e.g., paras. 0009 and 0011 of the present disclosure.)

While Applicant submits that the references did not teach or suggest all claim limitations as presented, Applicant has amended Claims 1, 4 and 6 to recite "a code generator" that creates "a unique hop pattern for each individual user." This amendment is made to further clarify the scope of the invention. Moreover, this limitation has been added to Claim 7, and all new Claims 8-13 further include this limitation. Accordingly, Applicant submits that the claims clearly state that this code generator is used to create a unique hop pattern for each individual user, a limitation not taught or suggested by the prior art references. Accordingly, Applicant respectfully submits that this rejection has been overcome.

Moreover, a *prima facie* case of obviousness was not made because the references do not teach or suggest the limitation directed to an analog battery-powered digital transmitter. The office action provides that the combination of Alstatt and Schotz's '343 Patent teaches a battery powered digital transmitter. Applicant respectfully submits that a *prima facie* case of obviousness has not been made. More particularly, the combination

of the battery-powered analog transmitter of Alstatt and the wall-powered digital transmitter of Schotz '343 would render Alstatt unsatisfactory for its intended purpose. Alstatt would suffer from a significantly reduced play time due to the power consumption of Schotz's numerous integrated circuits. Moreover, the Alstatt headphones for his portable device would be rendered too large because of the size of the integrated circuits used in Schotz.

For the same reasons of reduced play time and unwieldy headphones, the combination of Alstatt and Schotz would not provide a reasonable expectation of success. Accordingly, Applicant respectfully submits that a *prima facie* case of obviousness has not been made in this respect as well.

New limitations have been added to the new Claims 8-13, as discussed in Applicant's Examiner interview. New Claims 8 and 9 have been added to recite a channel decoder that permits soft-decision decoding. New Claims 10-11 have been added to recite a channel decoder that is a Viterbi decoder. (For further clarification, Claim 10, directed to the system, includes a limitation that the channel encoder is configured to send encoded symbols that are compatible with a Viterbi decoder). The specification has also been amended to recite that the channel decoder may be a Viterbi decoder. This material was present in the parent application to which the present application claims priority. [See page 4, line 27 of the parent application]

The Viterbi decoder--or a channel decoder that permits soft-decision decoding--is not taught or suggested by the prior art references. Schotz incorporates a 1/2 rate extended Golay block coding scheme. (Col. 9:19-26) Schotz's block coding scheme differs significantly from the coding scheme of the present claims. More particularly,

soft-decision coding may be used to prevent a greater band of interference than the Golay block coding scheme.

While the Viterbi channel encoding/decoding scheme permits hard decision coding as found in Schotz, it is the ability of this Viterbi scheme to further permit soft-decision coding that permits the Viterbi scheme to suppress a broader range of interference from other users. The Viterbi channel encoding/decoding scheme prevents interference (or jamming) from other system users. This interference can be represented as follower (or repeater) interference.

The follower (or repeater) jammer transmits frequency-hopped narrowband interference using the same hop sequence as the communicator, where the communicator is the primary user. This is equivalent to at least one additional system user in operation within the same space (or range) of a primary user. The follower (or repeater) jammers' output--resulting from use by other system users--must arrive at the primary user's frequency-hopping receiver hop frequency band space and dwell there long enough to cause interference before hopping to the next hop frequency band. The partial band jammer that is referenced in Schotz's design is defined as a transmitter (non-hopping type) that transmits its available power into a limited bandwidth which is smaller than the spread spectrum bandwidth. (See Schotz '343, para. 0016, lines 1-5)

Contrary to hard-decision decoding, soft-decision decoding includes additional information symbols to determining the reliability of the symbols being decoded. Included in the additional information symbols of the present invention is jammer state information (JSI). JSI includes information regarding the potential jamming threat, including the hop rate, dwell time, bandwidth, and so on, that would cause interference in

the system of the present disclosure. The JSI permits the receiver headphones to know if other system users are in the area, and if so, then the Viterbi decoder assigns less weight to the symbols that may be jammed so that it makes the a better estimate of the transmitted code sequence.

The Schotz design uses hard-decision decoding (see e.g., reference SRT241203) that does not incorporate JSI, as required with soft-decision decoding. In addition, Schotz states that forward error correction (see e.g., SRT241203) can be eliminated by frequency hopping is used in his design. (See Schotz para. 0016, lines 5-10)

Repeater jamming interference occurs when other system users are within relatively close range to one another. In accordance with the present invention, a repeater jammer transmits frequency-hopped narrow band interference using the same hop rate and dwell time as the primary user. This is the case for one or more other system users, because the same hop rate and dwell time is used for all system users, but each has a different PN code sequence. So, the repeater jammer (represented by other system users) may transmit an interference signal that may hop along with the primary system user to create interference in the receiver headphones of the primary system user. Schotz does not suppress this type of interference.

Schotz provides states that his system adds “control information” so there is no “need for independent stereos” in the same space. (See Schotz Abstract). Accordingly, Schotz does not design his system to function with multiple users (i.e., multiple stereos) in the same space. In fact, he teaches away from the use of independent stereos.

Schotz states the forward error correction is not needed (See Schotz at Column16:1-10). Further, the hard-decision decoder Schotz uses does not apply additional confidence symbols (like JSI) to maximize accurate decoding.

New Claims 12 and 13 have also been added to recite a 2.4 GHz direct conversion receiver. These receivers are compatible with systems incorporating frequency hopping spread spectrum (FHSS) transmission technology. Applicant respectfully submits that the prior art does not teach or suggest a direct conversion receiver. Schotz '343 incorporates a superheterodyne receiver that uses quadrature phase-shift keying as a modulation technique. This superheterodyne receiver incorporates filtering, oscillator and frequency synthesis components that are not needed when a direct conversion receiver is used. Moreover, at the time of Applicant's invention, the QPSK modulation technique was not compatible with modulation using frequency shift keying (FSK), so Schotz does not suggest a direct conversion receiver.

#### **Clarifying Amendments**

Minor amendments have further been made to the claims in order to correct typographical errors. More particularly, Claim 4 has been amended to recite that the method comprises the steps of various elements, with steps being plural instead of singular. Claim 4 has also been amended to recite, as part of the method "*communicating*" said analog music signal instead of "communication". Further, Claim 4 has been amended to delete reference to a distance of reception. The preambles of Claims 6 and 7 have been amended to delete reference, respectively, to "an analog headphone jack connected to a battery powered spread spectrum transmitter" and "to be

received by a battery powered spread spectrum headphone receiver." A semicolon has been added after the first element of Claim 7 directed to "a receiving antenna in communication with a spread spectrum headphone receiver."

Claim 6 has also been amended to recite that the battery powered digital transmitter is *configured to convert* an analog audio music signal, as opposed to "converts" an analog audio music signal.

### Conclusion

Applicant respectfully submits that the claims are in condition for allowance. A notice of allowance is respectfully requested.

While Applicant does not believe any fees are necessary since this response is submitted within the two-month window after the December 30, 2005 office action. However, if any such fees are deemed necessary, please charge any additional fees which may be required, or credit overpayment to Deposit Account No. 50-1946, referencing number 073785-0013.

Respectfully submitted,

March 13, 2006  
Date

Daphne L. Burton  
Daphne L. Burton  
Registration No. 45,323

MCDERMOTT WILL & EMERY, LLP  
2049 Century Park East, 34th Floor  
Los Angeles, CA 90067  
Telephone: (310) 277-4110  
Facsimile: (310) 277-4730

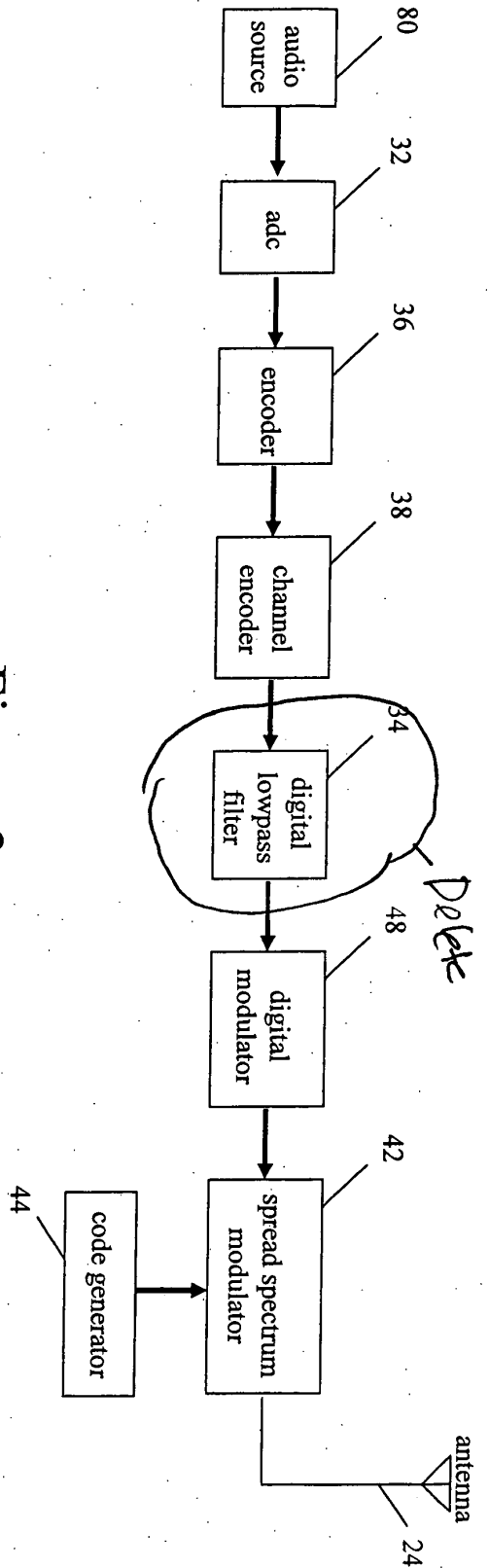

Figure 2

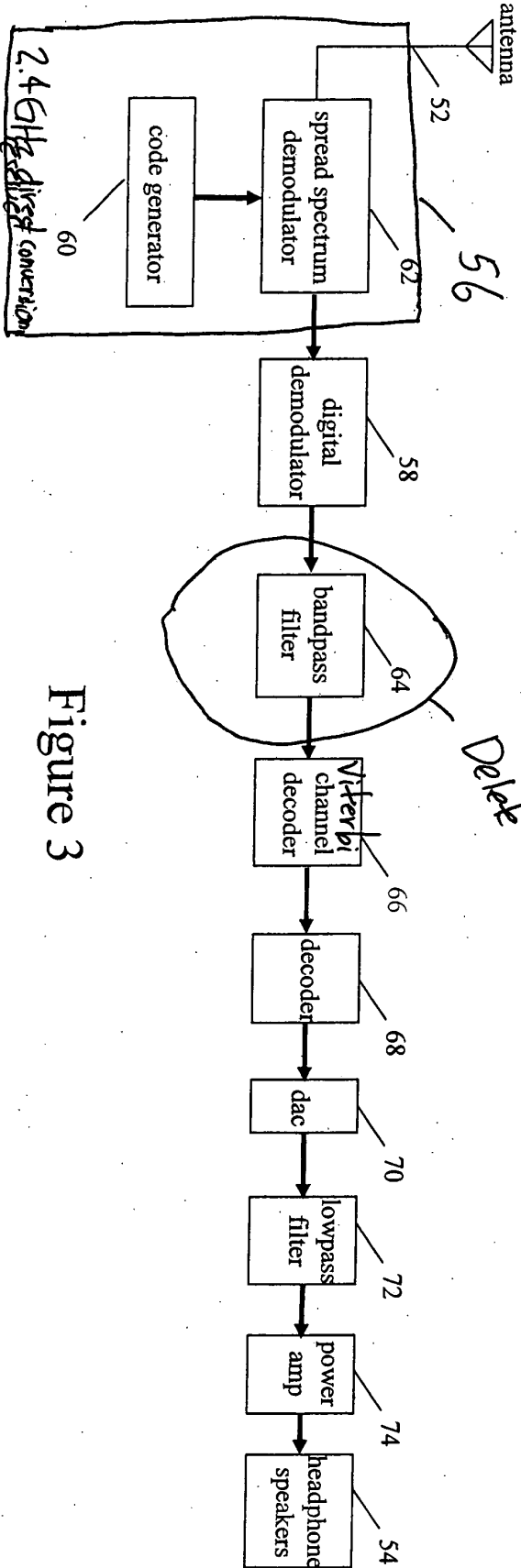

Figure 3

2.4GHz direct conversion

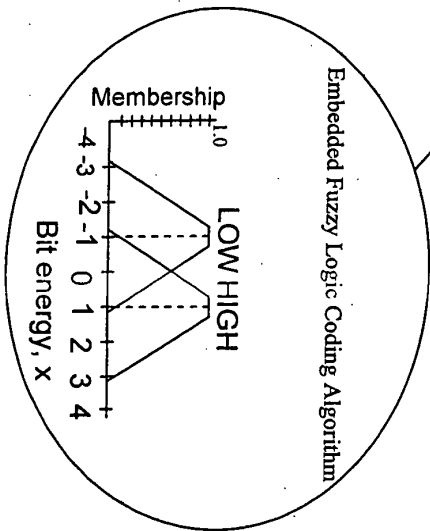
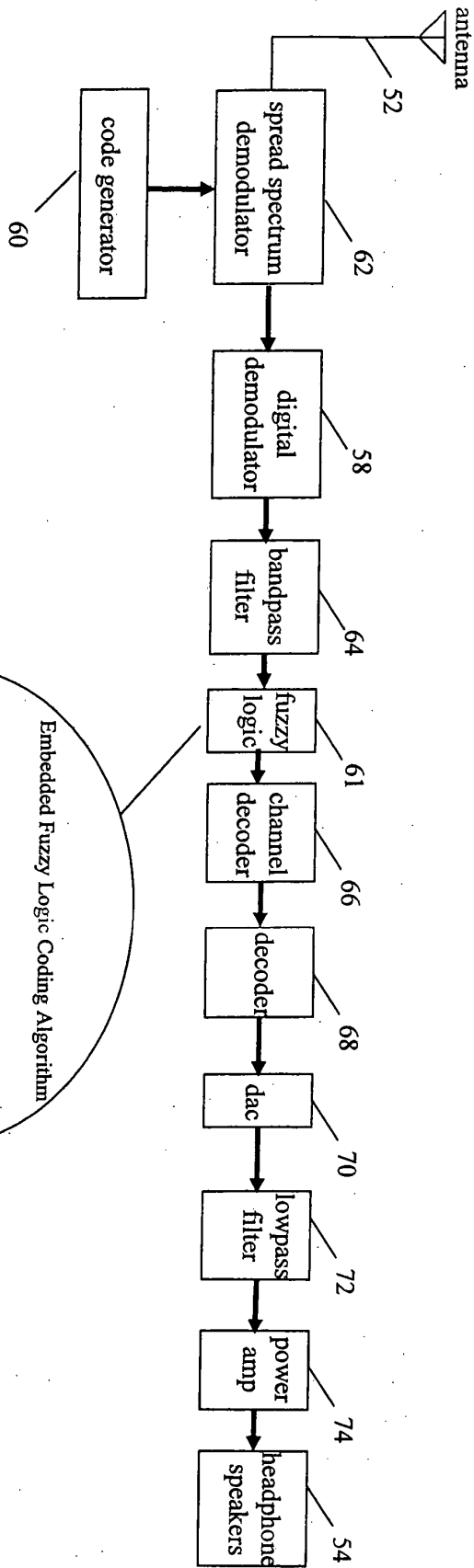

Figure 4



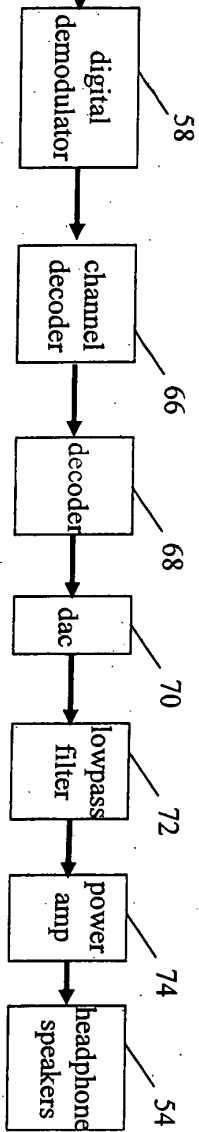
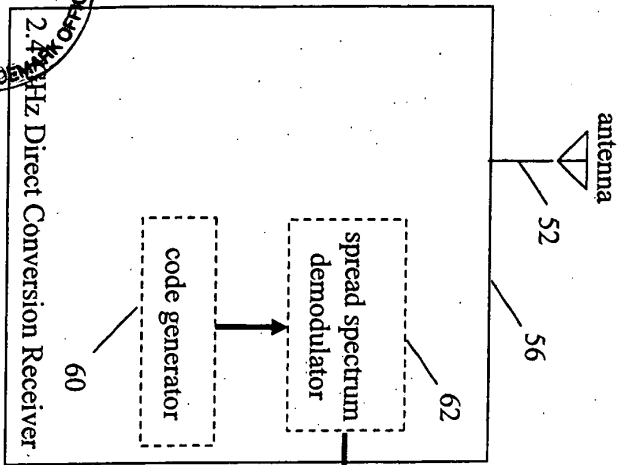

Figure 3

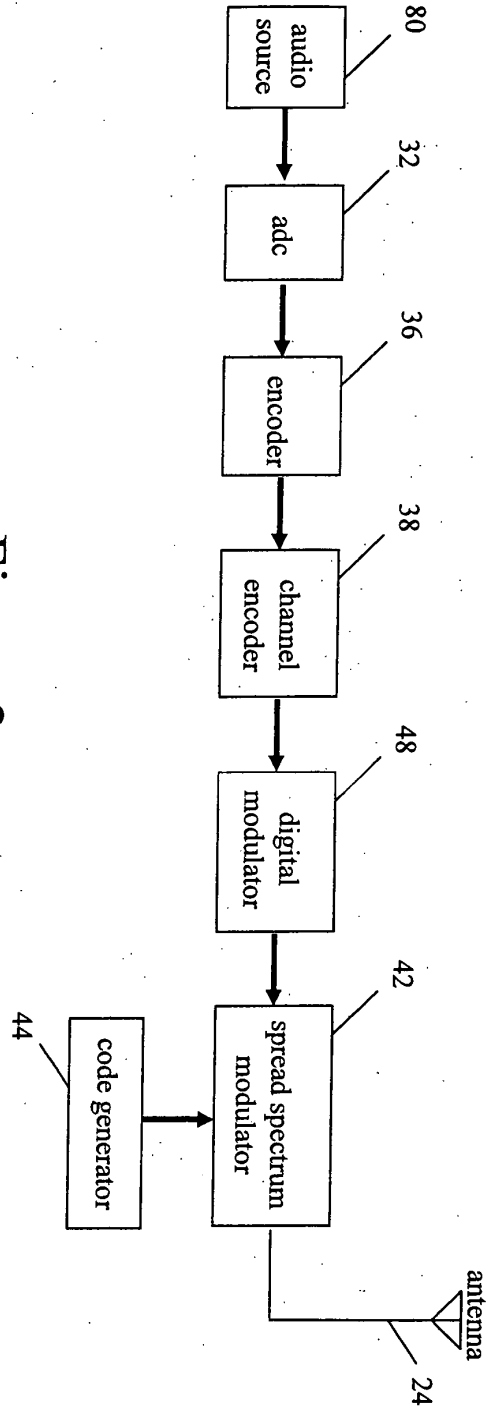

Figure 2

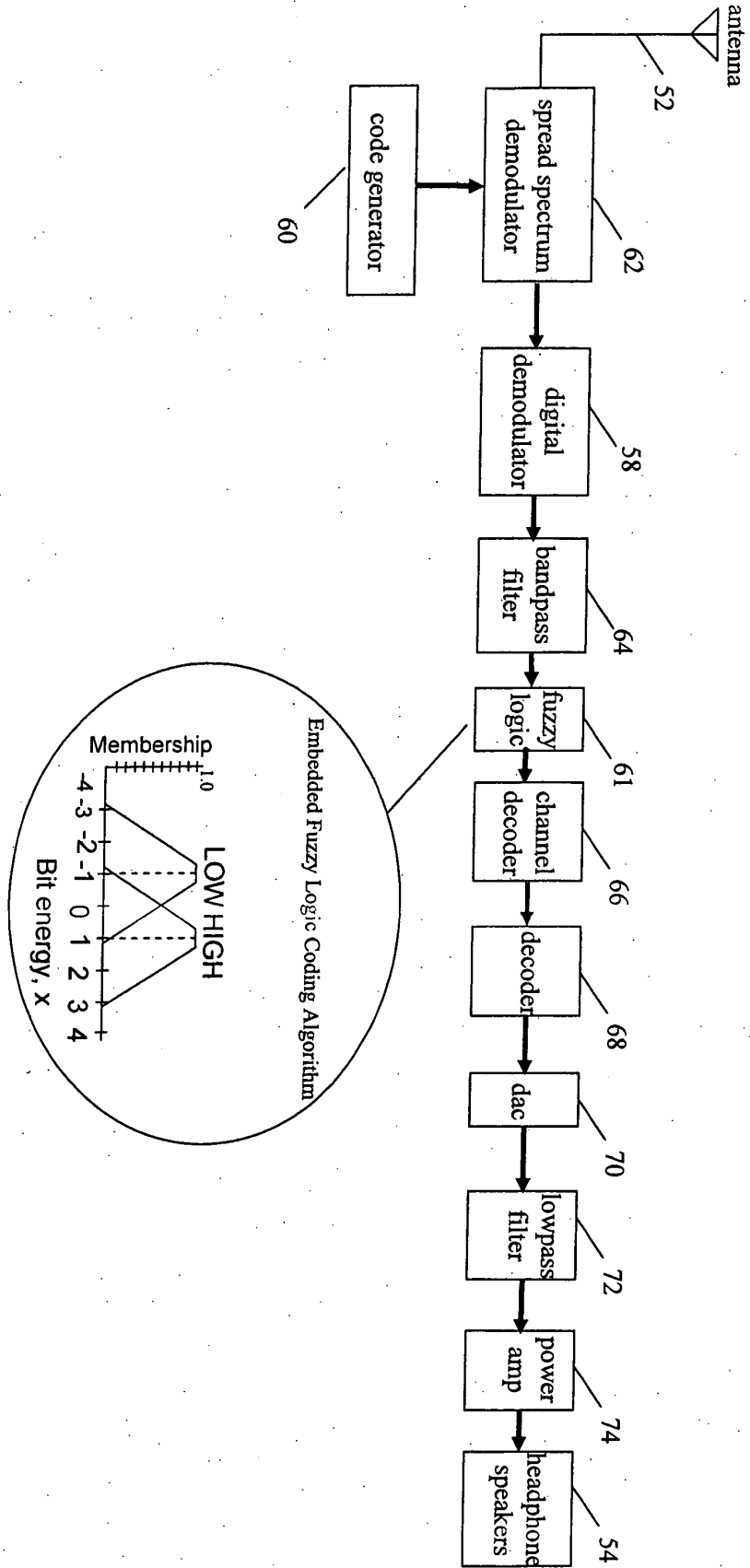

Figure 4

Under the Paperwork Reduction Act of 1995, no persons are required to respond to a collection of information unless it displays a valid OMB control number.

**PATENT APPLICATION FEE DETERMINATION RECORD**  
 Substitute for Form PTO-875

Application or Docket Number  
**1064802**

**CLAIMS AS FILED - PART I**

FOR	NUMBER FILED	NUMBER EXTRA
BASIC FEE (37 CFR 1.16(a))		
TOTAL CLAIMS (37 CFR 1.16(c))	minus 20 = *	
INDEPENDENT CLAIMS (37 CFR 1.16(b))	minus 3 = *	
MULTIPLE DEPENDENT CLAIM PRESENT (37 CFR 1.16(d))		

SMALL ENTITY	
RATE	FEE
	\$ ____
X \$ ____ =	
X \$ ____ =	
+ \$ ____ =	
TOTAL	

OTHER THAN SMALL ENTITY	
RATE	FEE
	\$ ____
X \$ ____ =	
X \$ ____ =	
+ \$ ____ =	
TOTAL	

\* If the difference in column 1 is less than zero, enter "0" in column 2.

*3/17/06*

**CLAIMS AS AMENDED - PART II**

	CLAIMS REMAINING AFTER AMENDMENT	MINUS	HIGHEST NUMBER PREVIOUSLY PAID FOR	PRESENT EXTRA
<b>AMENDMENT A</b>				
Total (37 CFR 1.16(c))	<b>10</b>	Minus	<b>20</b>	=
Independent (37 CFR 1.16(b))	<b>10</b>	Minus	<b>10</b>	=
FIRST PRESENTATION OF MULTIPLE DEPENDENT CLAIM (37 CFR 1.16(d))				

SMALL ENTITY	
RATE	ADDITIONAL FEE
X \$ ____ =	
X \$ ____ =	
+ \$ ____ =	
TOTAL ADD'L FEE	

OTHER THAN SMALL ENTITY	
RATE	ADDITIONAL FEE
X \$ ____ =	
X \$ ____ =	
+ \$ ____ =	
TOTAL ADD'L FEE	

	CLAIMS REMAINING AFTER AMENDMENT	MINUS	HIGHEST NUMBER PREVIOUSLY PAID FOR	PRESENT EXTRA
<b>AMENDMENT B</b>				
Total (37 CFR 1.16(c))	*	Minus	**	=
Independent (37 CFR 1.16(b))	*	Minus	***	=
FIRST PRESENTATION OF MULTIPLE DEPENDENT CLAIM (37 CFR 1.16(d))				

SMALL ENTITY	
RATE	ADDITIONAL FEE
X \$ ____ =	
X \$ ____ =	
+ \$ ____ =	
TOTAL ADD'L FEE	

OTHER THAN SMALL ENTITY	
RATE	ADDITIONAL FEE
X \$ ____ =	
X \$ ____ =	
+ \$ ____ =	
TOTAL ADD'L FEE	

	CLAIMS REMAINING AFTER AMENDMENT	MINUS	HIGHEST NUMBER PREVIOUSLY PAID FOR	PRESENT EXTRA
<b>AMENDMENT C</b>				
Total (37 CFR 1.16(c))	*	Minus	**	=
Independent (37 CFR 1.16(b))	*	Minus	***	=
FIRST PRESENTATION OF MULTIPLE DEPENDENT CLAIM (37 CFR 1.16(d))				

SMALL ENTITY	
RATE	ADDITIONAL FEE
X \$ ____ =	
X \$ ____ =	
+ \$ ____ =	
TOTAL ADD'L FEE	

OTHER THAN SMALL ENTITY	
RATE	ADDITIONAL FEE
X \$ ____ =	
X \$ ____ =	
+ \$ ____ =	
TOTAL ADD'L FEE	

- \* If the entry in column 1 is less than the entry in column 2, write "0" in column 3.
- \*\* If the "Highest Number Previously Paid For" IN THIS SPACE is less than 20, enter "20".
- \*\*\* If the "Highest Number Previously Paid For" IN THIS SPACE is less than 3, enter "3".

The "Highest Number Previously Paid For" (Total or Independent) is the highest number found in the appropriate box in column 1.

This collection of information is required by 37 CFR 1.16. The information is required to obtain or retain a benefit by the public which is to file (and by the USPTO to process) an application. Confidentiality is governed by 35 U.S.C. 122 and 37 CFR 1.14. This collection is estimated to take 12 minutes to complete, including gathering, preparing, and submitting the completed application form to the USPTO. Time will vary depending upon the individual case. Any comments on the amount of time you require to complete this form and/or suggestions for reducing this burden, should be sent to the Chief Information Officer, U.S. Patent and Trademark Office, U.S. Department of Commerce, P.O. Box 1450, Alexandria, VA 22313-1450. DO NOT SEND FEES OR COMPLETED FORMS TO THIS ADDRESS. SEND TO: Commissioner for Patents, P.O. Box 1450, Alexandria, VA 22313-1450.

If you need assistance in completing the form, call 1-800-PTO-9199 and select option 2.

**PATENT APPLICATION FEE DETERMINATION RECORD**  
Effective January 1, 2003

Application or Docket Number

10/649012

**CLAIMS AS FILED - PART I**

	(Column 1)	(Column 2)
TOTAL CLAIMS	5	
FOR	NUMBER FILED	NUMBER EXTRA
TOTAL CHARGEABLE CLAIMS	5 minus 20 =	15
INDEPENDENT CLAIMS	2 minus 3 =	1
MULTIPLE DEPENDENT CLAIM PRESENT <input type="checkbox"/>		

SMALL ENTITY TYPE <input type="checkbox"/>		OR	OTHER THAN SMALL ENTITY	
RATE	FEE		RATE	FEE
BASIC FEE	375.00	OR	BASIC FEE	750.00
X3 9=		OR	X3 18=	
X42=		OR	X34=	
+140=		OR	+280=	
TOTAL	375	OR	TOTAL	

\* If the difference in column 1 is less than zero, enter "0" in column 2

**CLAIMS AS AMENDED - PART II**

10/25/05

	(Column 1)	(Column 2)	(Column 3)
AMENDMENT A	CLAIMS REMAINING AFTER AMENDMENT	HIGHEST NUMBER PREVIOUSLY PAID FOR	PRESENT EXTRA
	Total	5 Minus 20 =	15
	Independent	3 Minus 3 =	0
FIRST PRESENTATION OF MULTIPLE DEPENDENT CLAIM <input type="checkbox"/>			

SMALL ENTITY TYPE <input type="checkbox"/>		OR	OTHER THAN SMALL ENTITY	
RATE	ADDITIONAL FEE		RATE	ADDITIONAL FEE
X3 9=		OR	X3 18=	
X42=		OR	X34=	
+140=		OR	+280=	
TOTAL ADDIT. FEE		OR	TOTAL ADDIT. FEE	

2/16/06

	(Column 1)	(Column 2)	(Column 3)
AMENDMENT B	CLAIMS REMAINING AFTER AMENDMENT	HIGHEST NUMBER PREVIOUSLY PAID FOR	PRESENT EXTRA
	Total	10 Minus 20 =	10
	Independent	10 Minus 4 =	6
FIRST PRESENTATION OF MULTIPLE DEPENDENT CLAIM <input type="checkbox"/>			

SMALL ENTITY TYPE <input type="checkbox"/>		OR	OTHER THAN SMALL ENTITY	
RATE	ADDITIONAL FEE		RATE	ADDITIONAL FEE
X3 9=		OR	X3 18=	
X42=	625	OR	X34=	
+140=		OR	+280=	
TOTAL ADDIT. FEE	625	OR	TOTAL ADDIT. FEE	

	(Column 1)	(Column 2)	(Column 3)
AMENDMENT C	CLAIMS REMAINING AFTER AMENDMENT	HIGHEST NUMBER PREVIOUSLY PAID FOR	PRESENT EXTRA
	Total	10 Minus 20 =	10
	Independent	10 Minus 4 =	6
FIRST PRESENTATION OF MULTIPLE DEPENDENT CLAIM <input type="checkbox"/>			

SMALL ENTITY TYPE <input type="checkbox"/>		OR	OTHER THAN SMALL ENTITY	
RATE	ADDITIONAL FEE		RATE	ADDITIONAL FEE
X3 9=		OR	X3 18=	
X42=		OR	X34=	
+140=		OR	+280=	
TOTAL ADDIT. FEE		OR	TOTAL ADDIT. FEE	

\* If the entry in column 1 is less than the entry in column 2, enter "0" in column 3.  
 \* If the "Highest Number Previously Paid For" IN THIS SPACE is less than 20, enter "20".  
 \* If the "Highest Number Previously Paid For" IN THIS SPACE is less than 4, enter "4".  
 \* The "Highest Number Previously Paid For" (Total or Independent) is the highest number found in the appropriate box in column 1.

## EAST Search History

Ref #	Hits	Search Query	DBs	Default Operator	Plurals	Time Stamp
S1	9	FHSS with unique with user	US-PGPUB; USPAT	OR	OFF	2006/05/02 17:46
S2	6	S1 and @ad<"20011221"	US-PGPUB; USPAT	OR	OFF	2006/05/02 17:45
S3	0	FHSS with unique adj hop	US-PGPUB; USPAT	OR	OFF	2006/05/02 17:46
S4	0	FHSS with each adj user	US-PGPUB; USPAT	OR	OFF	2006/05/02 17:46
S5	0	FHSS with individual adj user	US-PGPUB; USPAT	OR	OFF	2006/05/02 17:47
S6	0	(FHSS or "frequency hopping spread spectrum") with individual adj user	US-PGPUB; USPAT	OR	OFF	2006/05/02 17:47
S7	0	(FHSS or "frequency hopping spread spectrum") near user same unique	US-PGPUB; USPAT	OR	OFF	2006/05/02 17:47
S8	9	(FHSS or "frequency hopping spread spectrum") with user same unique	US-PGPUB; USPAT	OR	OFF	2006/05/02 17:48
S9	17	(FHSS or "frequency hopping spread spectrum") same unique same user	US-PGPUB; USPAT	OR	OFF	2006/05/02 17:48
S10	6	S9 and @ad<"20011221"	US-PGPUB; USPAT	OR	OFF	2006/05/02 17:48
S11	9	(FHSS or "frequency hopping spread spectrum") same multiple adj user!	US-PGPUB; USPAT	OR	OFF	2006/05/03 10:32
S12	91	(FHSS or "frequency hopping spread spectrum") same (pn or "hopping code")	US-PGPUB; USPAT	OR	OFF	2006/05/02 17:50
S13	13	(FHSS or "frequency hopping spread spectrum") with ("hopping code")	US-PGPUB; USPAT	OR	OFF	2006/05/02 17:50
S14	3	S13 and @ad<"20011221"	US-PGPUB; USPAT	OR	OFF	2006/05/02 17:51
S15	1	("5946343").PN.	US-PGPUB; USPAT	OR	OFF	2006/05/03 11:46
S16	1	("6342844").PN.	US-PGPUB; USPAT	OR	OFF	2006/05/03 11:46



UNITED STATES PATENT AND TRADEMARK OFFICE

*fw*

UNITED STATES DEPARTMENT OF COMMERCE  
United States Patent and Trademark Office  
Address: COMMISSIONER FOR PATENTS  
P.O. Box 1450  
Alexandria, Virginia 22313-1450  
www.uspto.gov

APPLICATION NO.	FILING DATE	FIRST NAMED INVENTOR	ATTORNEY DOCKET NO.	CONFIRMATION NO.
10/648,012	08/26/2003	C. Earl Woolfork	73785-013	3337

33401 7590 05/17/2006

MCDERMOTT, WILL & EMERY (LOS ANGELES OFFICE)  
2049 CENTURY PARK EAST  
34TH FLOOR  
LOS ANGELES, CA 90067-3208

EXAMINER

FLANDERS, ANDREW C

ART UNIT PAPER NUMBER

2615

DATE MAILED: 05/17/2006

Please find below and/or attached an Office communication concerning this application or proceeding.

<b>Office Action Summary</b>	<b>Application No.</b> 10/648,012	<b>Applicant(s)</b> WOOLFORK, C. EARL	
	<b>Examiner</b> Andrew C. Flanders	<b>Art Unit</b> 2615	

-- The MAILING DATE of this communication appears on the cover sheet with the correspondence address --

**Period for Reply**

A SHORTENED STATUTORY PERIOD FOR REPLY IS SET TO EXPIRE 3 MONTH(S) OR THIRTY (30) DAYS, WHICHEVER IS LONGER, FROM THE MAILING DATE OF THIS COMMUNICATION.

- Extensions of time may be available under the provisions of 37 CFR 1.136(a). In no event, however, may a reply be timely filed after SIX (6) MONTHS from the mailing date of this communication.
- If NO period for reply is specified above, the maximum statutory period will apply and will expire SIX (6) MONTHS from the mailing date of this communication.
- Failure to reply within the set or extended period for reply will, by statute, cause the application to become ABANDONED (35 U.S.C. § 133). Any reply received by the Office later than three months after the mailing date of this communication, even if timely filed, may reduce any earned patent term adjustment. See 37 CFR 1.704(b).

**Status**

- 1)  Responsive to communication(s) filed on 17 March 2006.
- 2a)  This action is FINAL.                      2b)  This action is non-final.
- 3)  Since this application is in condition for allowance except for formal matters, prosecution as to the merits is closed in accordance with the practice under *Ex parte Quayle*, 1935 C.D. 11, 453 O.G. 213.

**Disposition of Claims**

- 4)  Claim(s) 1,4 and 6-13 is/are pending in the application.
  - 4a) Of the above claim(s) \_\_\_\_\_ is/are withdrawn from consideration.
- 5)  Claim(s) \_\_\_\_\_ is/are allowed.
- 6)  Claim(s) 1,4 and 6-13 is/are rejected.
- 7)  Claim(s) \_\_\_\_\_ is/are objected to.
- 8)  Claim(s) \_\_\_\_\_ are subject to restriction and/or election requirement.

**Application Papers**

- 9)  The specification is objected to by the Examiner.
- 10)  The drawing(s) filed on 17 March 2006 is/are: a)  accepted or b)  objected to by the Examiner.  
 Applicant may not request that any objection to the drawing(s) be held in abeyance. See 37 CFR 1.85(a).  
 Replacement drawing sheet(s) including the correction is required if the drawing(s) is objected to. See 37 CFR 1.121(d).
- 11)  The oath or declaration is objected to by the Examiner. Note the attached Office Action or form PTO-152.

**Priority under 35 U.S.C. § 119**

- 12)  Acknowledgment is made of a claim for foreign priority under 35 U.S.C. § 119(a)-(d) or (f).
    - a)  All    b)  Some \*    c)  None of:
      - 1.  Certified copies of the priority documents have been received.
      - 2.  Certified copies of the priority documents have been received in Application No. \_\_\_\_\_.
      - 3.  Copies of the certified copies of the priority documents have been received in this National Stage application from the International Bureau (PCT Rule 17.2(a)).
- \* See the attached detailed Office action for a list of the certified copies not received.

**Attachment(s)**

- 1)  Notice of References Cited (PTO-892)
- 2)  Notice of Draftsperson's Patent Drawing Review (PTO-948)
- 3)  Information Disclosure Statement(s) (PTO-1449 or PTO/SB/08)  
Paper No(s)/Mail Date \_\_\_\_\_.
- 4)  Interview Summary (PTO-413)  
Paper No(s)/Mail Date \_\_\_\_\_.
- 5)  Notice of Informal Patent Application (PTO-152)
- 6)  Other: \_\_\_\_\_.

## DETAILED ACTION

### *Continued Examination Under 37 CFR 1.114*

A request for continued examination under 37 CFR 1.114, including the fee set forth in 37 CFR 1.17(e), was filed in this application after final rejection. Since this application is eligible for continued examination under 37 CFR 1.114, and the fee set forth in 37 CFR 1.17(e) has been timely paid, the finality of the previous Office action has been withdrawn pursuant to 37 CFR 1.114. Applicant's submission filed on 17 March 2006 has been entered.

### *Response to Arguments*

Applicant's arguments filed 17 March 2006 have been fully considered but they are not persuasive.

Applicant alleges:

"Moreover, a prima facie case of obviousness was not made because the references do not teach or suggest the limitation directed to an analog battery-powered digital transmitter. The office action provides that the combination of Alstatt and Schotz's '343 Patent teaches a battery powered digital transmitter. Applicant respectfully submits that a prima facie case of obviousness has not been made. More particularly, the combination of the battery-powered analog transmitter of Alstatt and the wall-powered digital transmitter of Schotz '343 would render Alstatt unsatisfactory for its intended purpose. Alstatt would suffer from a significantly reduced play time due to the power consumption of Schotz's numerous integrated circuits. Moreover, the Alstatt headphones for his



portable device would be rendered too large because of the size of the integrated circuits used in Schotz.”

Examiner respectfully disagrees with this allegation. The combination of Alstatt in view of Schotz does teach an analog batter-powered digital transmitter as shown on page 6 and 8 of the previous office action. Alstatt discloses a analog battery powered transmitter (14) while Schotz discloses a digital transmitter (22).

Applicant’s further allegations that the wall-powered digital transmitter in Schotz would render Alstatt unsatisfactory are unfounded. Neither Schotz nor Alstatt gives any indication as to the power requirements of the various components used in the combination. As such, the Examiner can find no evidence that Alstatt would suffer from a significantly reduced play time due to the power consumption of Schotz’s numerous integrated circuits. If Applicant is in possession (and wishes to maintain this argument) of such evidence, detailing the power requirements of the components used in the combination, the Examiner respectfully requests these documents.

Applicant states:

“New limitations have been added to the new Claims 8-13, as discussed in Applicant’s Examiner interview. New Claims 8 and 9 have been added to recite a channel decoder that permits soft-decision decoding. New Claims 10-11 have been added to recite a channel decoder that is a Viterbi decoder. (For further clarification, Claim 10, directed to the system, includes a limitation that the channel encoder is configured to send encoded symbols that are compatible with a Viterbi decoder). The specification has also been amended to recite that the channel decoder may be a Viterbi decoder. This material was present in the parent application to which the present application claims priority. (See page 4, line 27 of the parent application).”

The details of the Viterbi decoder are present in the cited reference given by the applicant. However, the limitation of the soft-decision decoding is not present in either of the disclosures. While it is known that the Viterbi decoder is able to perform soft-decision decoding, the disclosure's relied upon lack sufficient description for one of ordinary skill in the art to reproduce this implementation.

Applicant's remaining arguments have been considered but are moot in view of the new ground(s) of rejection necessitated by Applicant's amendments.

### ***Drawings***

New corrected drawings in compliance with 37 CFR 1.121(d) are required in this application because Figure 2 incorporates new matter, which is prohibited by 37 CFR 1.121(f).

The drawings submitted 17 March 2006 show the code generator (60) and spread spectrum demodulator (62) integrated to form the direct conversion receiver 56. A 2.4 GHz direct conversion receiver is not previously disclosed including these two elements as shown in the present drawings and thus create a new matter situation. A direct conversion receiver (56) is shown in the parent application's drawings (Fig. 3

element 56) but the demodulator (62) and code generator (60) are shown as separate components.

### ***Specification***

The amendment filed 17 March 2006 is objected to under 35 U.S.C. 132(a) because it introduces new matter into the disclosure. 35 U.S.C. 132(a) states that no amendment shall introduce new matter into the disclosure of the invention. The added material which is not supported by the original disclosure is as follows:

1. "A channel decoder 66 may be in communication with the band pass filter."

Examiner is unable to find a basis for this in either the specification or the drawings. In the parent application the decoder (66) is not directly connected to the band pass filter (54) and thus cannot be in communication with it. Additionally the decoder and BPF in Fig. 3 of the present application are not shown to be in communication with each other as there exists a fuzzy logic detector (61) between.

2. "The received spread spectrum signal may be communicated to a 2.4 GHz direct conversion receiver 56."

The new drawings submitted 17 March 2006 show the code generator (60) and spread spectrum demodulator (62) integrated to form the direct conversion receiver 56.

A 2.4 GHz direct conversion receiver is not previously disclosed including these two elements as shown in the present drawings and thus create a new matter situation. A direct conversion receiver (56) is shown in the parent application's drawings (Fig. 3 element 56) but the demodulator (62) and code generator (60) are shown as separate components.

3. "A frequency shift keying (FSK) modulation/detection technique could be used given a frequency hopping spread spectrum (FHSS) system choice."

The terms and techniques disclosed in this sentence (FSK and FHSS) were not present in the parent disclosure nor in the current application's disclosure and thus are new matter.

4. "The direct conversion receiver 56 may provide a means to convert the received signal while using timing and synchronization to capture the correct bit sequence embedded in the received spread spectrum signal."

The means to convert has previously only be described as a down conversion processes in the parent application (paragraphs 15 and 16). The phrase "means to convert" implies other forms of conversion in addition to the down conversion thus creating a new matter situation.

Applicant is required to cancel the new matter in the reply to this Office Action.

***Claim Rejections - 35 USC § 112***

The following is a quotation of the first paragraph of 35 U.S.C. 112:

The specification shall contain a written description of the invention, and of the manner and process of making and using it, in such full, clear, concise, and exact terms as to enable any person skilled in the art to which it pertains, or with which it is most nearly connected, to make and use the same and shall set forth the best mode contemplated by the inventor of carrying out his invention.

**Claims 1, 4, 6, ~~8, 9~~, 10, 12 and 13** are rejected under 35 U.S.C. 112, first  paragraph, as failing to comply with the written description requirement. The claim(s) contains subject matter which was not described in the specification in such a way as to reasonably convey to one skilled in the relevant art that the inventor(s), at the time the application was filed, had possession of the claimed invention. The newly added limitation of "a unique hop pattern for each individual user" is not supported in the disclosure of neither the present application nor the parent application. The relied upon disclosures teach generating a unique user code with one user but do not disclose any details on creating a unique "hop pattern" for each individual user.

**Claims 12 and 13** are rejected under 35 U.S.C. 112, first paragraph, as failing to comply with the written description requirement. The claim(s) contains subject matter which was not described in the specification in such a way as to reasonably convey to one skilled in the relevant art that the inventor(s), at the time the application was filed, had possession of the claimed invention. The newly added limitation of "a 2.4 GHz direct conversion receiver that includes a spread spectrum communication demodulator

and a receiver code generator" is not supported in the disclosure of neither the present application nor the parent application. These components were only disclosed in the parent application's fig. 2 in which they are shown as discrete components.

**Claim 8 and 9** are rejected under 35 U.S.C. 112, first paragraph, as based on a disclosure which is not enabling. Claims 8 and 9 recite a limitation of a channel decoder that is configured to perform soft-decision decoding which is considered to be critical or essential to the practice of the invention, but is not enabled by the disclosure.

***Claim Rejections - 35 USC § 103***

The following is a quotation of 35 U.S.C. 103(a) which forms the basis for all obviousness rejections set forth in this Office action:

(a) A patent may not be obtained though the invention is not identically disclosed or described as set forth in section 102 of this title, if the differences between the subject matter sought to be patented and the prior art are such that the subject matter as a whole would have been obvious at the time the invention was made to a person having ordinary skill in the art to which said subject matter pertains. Patentability shall not be negated by the manner in which the invention was made.

*1, 4, 6-9 and 11-13 are*  
**Claim 4** is rejected under 35 U.S.C. 103(a) as being unpatentable over Alstatt *50*

(U.S. Patent 5,771,441) in view of Schotz (U.S. Patent 5,946,343) and in further view of Schotz (U.S. Patent 5,491,839) and in further view of Rozin (U.S. Patent 6,342,844)

Regarding **Claim 1**,

Alstatt teaches an audio dongle for an utilizes a RF connection to interface portable audio device a pair of wireless headphones.

Specifically regarding Claim Alstatt teaches:

A wireless audio music system (Figure 1) for communication of an audio music signal (from 10) from the analog headphone jack (12) connected to a battery powered transmitter (14) and received by a battery powered headphone receiver (col. 4 lines 29-53; battery transmitter 43 col. 6, line 54; battery for headphone receiver is implicit the wireless nature of the headphones and context Alstatt) comprising:

an analog headphone jack (12) from an audio music source (10) in communication with a batter powered digital transmitter (14) (col. 4 lines 29 – 39)

The headphone system of Altstatt includes an antenna (24), receiver (22) and earphones 26 and 28.

However, the system of Altstatt an analog transmission system that, operation, lacks the benefits digitally encoded and transmitted audio signal.

With regard to the limitations of Claim 1, Altstatt does not clearly teach or suggest:

A wireless digital audio music system for spread spectrum communication  
said battery powered digital transmitter converts an analog audio music signal from said existing analog headphone jack to a digital signal using an ADC in communication with an encoder

said encoder in communication with a channel encoder

said digital modulator in communication with a spread spectrum communication modulator that utilizes a code generator to create a unique hop pattern for each individual user;

said spread spectrum communication modulator in communication with a transmit antenna that transmits a radio frequency of approximately 2.4 GHz for receipt by a receiving antenna;

said receiving antenna in communication with a spread spectrum communication demodulator

said spread spectrum communication demodulator in communication with a receiver code generator and with a digital demodulator;

said digital demodulator in communication with a wide bandpass filter

said wide bandpass filter in communication with a channel decoder;

said channel decoder in communication with a receiver decoder;

said DAC in communication with a filter to pass the analog music signal in the approximate frequency band of 20Hz to 20 kHz; and

said filter passing analog music signal will be amplified for processing to a speaker headphone set to provide high quality music for listening by a signal user wearing the headphones.

Schotz et al discloses a wireless digital audio transmission system.

Specifically regarding Claim 1, Schotz et al, when considered in view of the teachings of Altstatt applied above, teaches or at least suggests:



A wireless digital audio music system for spread spectrum communication  
(Figure 1 of Schott et al in view of Figure 1 of Altstatt, col. 6, lines 6-54; col. 14, lines 5-12)

said digital transmitter (22 of Schotz et al in view of 14 of Altstatt) converts an analog audio music signal from said existing analog headphone jack (analog input 30A,30B of Schott et al in view of analog connection 12,18 of Altstatt) to a digital signal using an ADC (52) in communication with an encoder (300) (col. 7, lines 6-15; col. 14, lines 43-58, as noted above 'in communication' has been interpreted herein to mean passing a signal between the two components, regardless of other components that may be disposed between two said components)

said encoder (300) in communication with a channel encoder (98) (col. 9, lines 1-48; col. 14, lines 61-65)

said digital modulator (102) in communication with a spread spectrum communication modulator (104) that utilizes a code generator (106,308) (102 modulates input signal to produce I,Q signals, col. 10, lines 17-24; spread spectrum, col. 14, lines 5-12, col. 15, lines 40-52; code generator and user code corresponds to either house select code or PN code, col. 10, lines 43-47 or col. 15, lines 40-52; either can be considered to generate 'user codes' in context of Schotz et al and particularly Altstatt in that the use of a transmitter corresponds to a particular user operating said transmitter);

said spread spectrum communication modulator (104) in communication (via 108) with a transmit antenna (38) that transmits at a radio frequency of approximately 2.4 GHz for receipt by a receiving antenna (40) (col. 6, lines 39-42; col. 10, lines 31-37)

said receiving antenna (40) in communication with a spread spectrum communication demodulator (comprising 144,146,148; col. 11, line 13 - col. 12, line 24; col. 15, lines 45-52)

said spread spectrum communication demodulator (144,146,148) in communication with a receiver code generator (408 or house code generator, col. 11, lines 13-56; col. 15, lines 45-52) and with a digital demodulator (202)(202 reverses phase shift modulation and combines signals, col. 12, lines 41-47);

said digital demodulator (202) in communication with a wide bandpass filter (such as 138 or 142 or 178, via components of 140,146) (col. 11, lines 14-24, col. 12, lines 1-11, noting that audio signals require wideband transmission col. 2, lines 58-60, which infers such a wideband nature on these filters);

said wide bandpass filter (such as 138 or 142 or 178) in communication (via components of 140,146) with a channel decoder (198) (col. 12, lines 1-28);

said channel decoder (198) in communication with a receiver decoder (400)(col. 15, lines 10-18);

said receiver decoder (400)in communication with a DAC (216) (col. 15, lines 10-26);

said DAC (216) in communication with a filter (218A,2185) to pass the analog music signal in the approximate frequency band of 20Hz to 20 kHz (signal is music, col. 2, lines 55-58; filtering col. 13, lines 57-67)

To one of ordinary skill in the art at the time the invention was made, it would have been obvious to modify the wireless audio system of Altstatt to incorporate the

digital transmission and reception scheme of Schotz et al for the wireless communication of full range audio data. The motivation behind such a modification would have been that such a digital transmission would have provided a number of benefits, including the reception of CD-quality sound and forwarding error correction, the latter of which would have enabled the system to account for errors in transmission. The digital-based system of Schotz et al would have also enabled the option of muting the output signal in the presence of sufficient levels of error. The spread spectrum technique of Schotz et al would have also limited interference from another signal to cause error in only one portion of the transmitted signal rather than the entire signal. Further, the transmission components of Schotz et al would have also permitted transmission over unlicensed frequency bands.

while the system of Altstatt in view of Schotz et al discloses a variety of filtering and other signal modifications, Altstatt in view of Schotz et al is not considered to clearly teach or suggest:

said channel encoder in communication with a digital low pass filter  
said digital low pass filter in communication with a digital modulator  
said DAC in communication with a filter that is a low pass filter  
said filter passing analog music signal will be amplified for processing to a speaker headphone set to provide high quality music for listening by a single user wearing the headphones

However, Schotz et al incorporates another digital wireless system by reference, issued to Schotz.

Specifically regarding the limitations of Claim 1, Schotz, in view of the teachings of Altstatt and Schotz et al as applied above, teaches or at least suggests:

said channel encoder (300 of Schotz et al) in communication with a digital low pass filter (60 of Schotz)(col. 6, lines 41-53 of Schotz for lowpass filtering buffer 60, in view of modification listed below)

said digital low pass filter (60) in communication with a digital modulator (102 of Schotz et al)(col. 6, lines 41-53 of Schotz for lowpass filtering buffer 60, in view of modification listed below)

said DAC (216 of Schotz et al, which provides output signal) in communication with a filter that is a low pass filter (152 of Schotz in view of 218A, B of Schotz et al)

said filter (152) passing analog music signal will be amplified (by 156) for processing to a speaker headphone set (Figure 1 of Schotz, in view of headphones of Altstatt) to provide high quality music for listening by a single user wearing the headphones (col. 4, lines 2-5; col. 10, lines 19-22, noting that signal expansion is one form of amplitude control; it is further noted that otherwise output amplifying an audio signal for application to speakers is substantially well-known in the art).

To one of ordinary skill in the art at the time the invention was made, it would have been obvious to incorporate the low-pass filtering buffer of Schotz as part of the circuitry processing the output signal of the ADC (that is, as part of the signal path following the ADC) in the transmitter of Altstatt in view of Schatz et al. The motivation behind such a modification would have been that such a filtering buffer would have removed high frequency harmonics resulting from the multiplexing of the signal in the

ADC. To one of ordinary skill in the art at the time the invention was made, it would have been obvious to incorporate low pass filtering as taught by Schotz for the output filters of Altstatt in view of Schotz et al. The motivation behind such a modification would have been that such low pass filtering would have enabled the removal of any pilot or multiplexing byproducts yet present in the output signal. To one of ordinary skill in the art at the time the invention was made, it would have been obvious to incorporate the compression and expansion circuitry of Schotz as part of the input and output handling circuitry of the system of Altstatt in view of Schotz et al. The motivation behind such a modification would have been that such a form of signal amplitude control would have placed the throughput audio signals within the linear operating ranges of the audio channels in the transmitter and receiver.

Additionally, the combination shown above fails to explicitly disclose that the code generator creates a unique hop pattern for each individual user. As shown above, the Schotz reference in the combination discloses a code generator (106,308).

While it is not taught to use a unique hop pattern for each individual user, doing so in a FHSS implementation (which is suggested by Schotz; col. 14 lines 5 – 12) is notoriously well known in the art.

Rozin discloses a code generator that creates a unique hop pattern for each individual user (col. 9 lines 52 – 67 and col. 10 lines 1 – 27).

While Rozin is not directed to the digital audio art, since FHSS is used, the data that is coded is irrelevant. It would have been obvious to one of ordinary skill in the art to apply Rozin's teachings to the combination disclosed above. One would have been

Art Unit: 2615

motivated to do so to avoid interference, collisions, and interceptions (col. 10 lines 13 – 17 of Rozin) between the various devices in the household disclosed by Schotz.

Regarding **Claim 4**, please refer above to the functions-corresponding to the components cited above in the rejection of the similar limitations of Claim 1. The citations provided therein form the basis for the rejection of the similar limitations of the method steps of Claim 4. In addition, the claimed power level and distance of approximately 10 ft is at least considered suggested by Schott et al's reference to a range within 10 ft (col. 5, lines 26-36).

Regarding **Claim 6**, please refer above to the components cited above in the rejection of the similar limitations of Claim 1, particularly the first portion of Claim 1. The citations provided therein form the basis for the rejection of the similar limitations of the apparatus of Claim 6.

Regarding **Claim 7**, please refer above to the components cited above in the rejection of the similar limitations of Claim 1, particularly the first portion of Claim 1. The citations provided therein form the basis for the rejection of the similar limitations of the apparatus of Claim 7.

Regarding **Claim 8**, please refer above to the components cited above in the rejection of the similar limitations of Claim 1. The citations provided therein form the basis for the rejection of the similar limitations of the system of claim 8.

However, the combination in claim 1 does not disclose that the channel decoder is configured to perform soft-decision decoding.

The Examiner takes Official notice that soft decision Viterbi decoders are notoriously well known in the art (See wikipedia.com entries for Viterbi decoder and Viterbi Algorithm). Applying the teachings of these entries to the combination reads upon the limitation of the channel decoder is configured to perform soft-decision decoding.

It would have been obvious to one of ordinary skill in the art at the time of the invention to modify the combination's decoder to perform as a soft-decision Viterbi decoder. Viterbi decoders or often used in telecommunication lines and for amateur radio and radio relay (see wikipedia Viterbi entries). It would be an advantage to use the Viterbi decoder in the combinations circuitry because Viterbi decoding has an advantage of a fix decoding time making it well suited for hardware decoder implementation (Flemming).

Regarding **Claim 9**, please refer above to the components cited above in the rejection of the similar limitations of Claim 7. The citations provided therein form the basis for the rejection of the similar limitations of the apparatus of Claim 9.

However, the combination in claim 7 does not disclose that the channel decoder is configured to perform soft-decision decoding.

The Examiner takes Official notice that soft decision Viterbi decoders are notoriously well known in the art (See wikipedia.com entries for Viterbi decoder and Viterbi Algorithm). Applying the teachings of these entries to the combination reads upon the limitation of the channel decoder is configured to perform soft-decision decoding.

It would have been obvious to one of ordinary skill in the art at the time of the invention to modify the combination's decoder to perform as a soft-decision Viterbi decoder. Viterbi decoders are often used in telecommunication lines and for amateur radio and radio relay (see wikipedia Viterbi entries). It would be an advantage to use the Viterbi decoder in the combinations circuitry because Viterbi decoding has an advantage of a fixed decoding time making it well suited for hardware decoder implementation (Flemming).

Regarding **Claim 9**, please refer above to the components cited above in the rejection of the similar limitations of Claim 1. The citations provided therein form the basis for the rejection of the similar limitations of the apparatus of Claim 9.

However, the combination in claim 1 does not disclose that the channel encoder is configured to send encoded symbols that are compatible with a Viterbi decoder or that the decoder is a Viterbi decoder.



The Examiner takes Official notice that soft decision Viterbi decoders are notoriously well known in the art (See wikipedia.com entries for Viterbi decoder and Viterbi Algorithm). Applying the Viterbi decoding method disclosed in these entries would read upon the limitations of the channel encoder is configured to send encoded symbols that are compatible with a Viterbi decoder or that the decoder is a Viterbi decoder.

It would have been obvious to one of ordinary skill in the art at the time of the invention to modify the combination's decoder to perform as a soft-decision Viterbi decoder. Viterbi decoders are often used in telecommunication lines and for amateur radio and radio relay (see wikipedia Viterbi entries). It would be an advantage to use the Viterbi decoder in the combinations circuitry because Viterbi decoding has an advantage of a fixed decoding time making it well suited for hardware decoder implementation (Flemming).

Regarding **Claim 11**, please refer above to the components cited above in the rejection of the similar limitations of Claim 9. The citations provided therein form the basis for the rejection of the similar limitations of the apparatus of Claim 11.

Regarding **Claim 12**, please refer above to the components cited above in the rejection of the similar limitations of Claim 1. The citations provided therein form the basis for the rejection of the similar limitations of the apparatus of Claim 12.

In addition, the combination further discloses a 2.4 GHz direct conversion receiver that includes a spread spectrum communication demodulator and a receiver code generator (Schotz elements 40, 106,308, 144,146,148; col. 11, line 13 - col. 12, line 24; col. 15, lines 45-52).

Regarding **Claim 13**, please refer above to the components cited above in the rejection of the similar limitations of Claim 7. The citations provided therein form the basis for the rejection of the similar limitations of the apparatus of Claim 13.

In addition, the combination further discloses a 2.4 GHz direct conversion receiver that includes a spread spectrum communication demodulator and a receiver code generator (Schotz elements 40, 106,308, 144,146,148; col. 11, line 13 - col. 12, line 24; col. 15, lines 45-52).

### ***Conclusion***

Any inquiry concerning this communication or earlier communications from the examiner should be directed to Andrew C. Flanders whose telephone number is (571) 272-7516. The examiner can normally be reached on M-F 8:30 - 5:00.

If attempts to reach the examiner by telephone are unsuccessful, the examiner's supervisor, Sinh Tran can be reached on (571) 272-7546. The fax phone number for the organization where this application or proceeding is assigned is 571-273-8300.

Information regarding the status of an application may be obtained from the Patent Application Information Retrieval (PAIR) system. Status information for published applications may be obtained from either Private PAIR or Public PAIR. Status information for unpublished applications is available through Private PAIR only. For more information about the PAIR system, see <http://pair-direct.uspto.gov>. Should you have questions on access to the Private PAIR system, contact the Electronic Business Center (EBC) at 866-217-9197 (toll-free).

acf



**SINH TRAN**  
**SUPERVISORY PATENT EXAMINER**

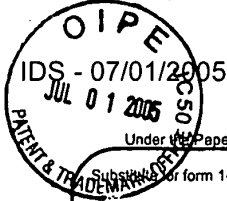

PTO/SB/08B (08-03)  
 Approved for use through 07/31/2006. OMB 0651-0031  
 U.S. Patent and Trademark Office; U.S. DEPARTMENT OF COMMERCE

Under the Paperwork Reduction Act of 1995, no persons are required to respond to a collection of information unless it contains a valid OMB control number.

<b>INFORMATION DISCLOSURE STATEMENT BY APPLICANT</b> (Use as many sheets as necessary)		<b>Complete if Known</b>	
		Application Number	10/648,012
		Filing Date	08-26-2003
		First Named Inventor	C. Earl Woolfork
		Art Unit	2644
		Examiner Name	Graham, Andrew R. <i>Flanders, Andrew</i>
Sheet 1	of 1	Attorney Docket Number	None

NON PATENT LITERATURE DOCUMENTS			
Examiner Initials*	Cite No. <sup>1</sup>	Include name of the author (in CAPITAL LETTERS), title of the article (when appropriate), title of the item (book, magazine, journal, serial, symposium, catalog, etc.), date, page(s), volume-issue number(s), publisher, city and/or country where published.	T <sup>2</sup>
ACF		"Digital Communication Techniques" by Simon, Hinedi and Lindsey	
ACF		"Wireless Communications" by Rappaport	
ACF		"Communication Networks" by Walrand	
ACF		"Unified Analysis of Certain Coherent and Noncoherent Binary Communications Systems" by Stein in IEEE Transactions on Information Theory, January 1964	

Examiner Signature	/Andrew Flanders/	Date Considered	05/03/2006
--------------------	-------------------	-----------------	------------

\*EXAMINER: Initial if reference considered, whether or not citation is in conformance with MPEP 609. Draw line through citation if not in conformance and not considered. Include copy of this form with next communication to applicant.  
<sup>1</sup> Applicant's unique citation designation number (optional). <sup>2</sup> Applicant is to place a check mark here if English language Translation is attached. This collection of information is required by 37 CFR 1.98. The information is required to obtain or retain a benefit by the public which is to file (and by the USPTO to process) an application. Confidentiality is governed by 35 U.S.C. 122 and 37 CFR 1.14. This collection is estimated to take 2 hours to complete, including gathering, preparing, and submitting the completed application form to the USPTO. Time will vary depending upon the individual case. Any comments on the amount of time you require to complete this form and/or suggestions for reducing this burden, should be sent to the Chief Information Officer, U.S. Patent and Trademark Office, P.O. Box 1450, Alexandria, VA 22313-1450. DO NOT SEND FEES OR COMPLETED FORMS TO THIS ADDRESS. SEND TO: Commissioner for Patents, P.O. Box 1450, Alexandria, VA 22313-1450.

If you need assistance in completing the form, call 1-800-PTO-9199 (1-800-786-9199) and select option 2.

<b>Notice of References Cited</b>	Application/Control No. 10/648,012	Applicant(s)/Patent Under Reexamination WOOLFORK, C. EARL	
	Examiner Andrew C. Flanders	Art Unit 2615	Page 1 of 1

**U.S. PATENT DOCUMENTS**

*	Document Number Country Code-Number-Kind Code	Date MM-YYYY	Name	Classification
*	A US-5,771,441	06-1998	Altstatt, John E.	455/66.1
*	B US-5,946,343	08-1999	Schotz et al.	375/141
*	C US-5,491,839	02-1996	Schotz, Larry	455/39
*	D US-6,342,844	01-2002	Rozin, Alexander	340/933
	E US-			
	F US-			
	G US-			
	H US-			
	I US-			
	J US-			
	K US-			
	L US-			
	M US-			

**FOREIGN PATENT DOCUMENTS**

*	Document Number Country Code-Number-Kind Code	Date MM-YYYY	Country	Name	Classification
	N				
	O				
	P				
	Q				
	R				
	S				
	T				

**NON-PATENT DOCUMENTS**

*	Document Number Country Code-Number-Kind Code	Date MM-YYYY	Country	Name	Classification
	Include as applicable: Author, Title Date, Publisher, Edition or Volume, Pertinent Pages)				
	U			wikipeda.com entry for Viterbi Decoder	
	V			wikipedia.com entry for Viterbi Algorithm	
	W			A Tutorial on Convolutional Coding with Viterbi Decoding; Chip Flemming	
	X				

\*A copy of this reference is not being furnished with this Office action. (See MPEP § 707.05(a).)  
Dates in MM-YYYY format are publication dates. Classifications may be US or foreign.

**Index of Claims**



Application/Control No.

10/648,012

Examiner

Andrew ~~Cochran~~

*Fladers*

Applicant(s)/Patent under Reexamination

WOOLFORK, C. EARL

Art Unit

2644

✓	Rejected
=	Allowed

-	(Through numeral) Cancelled
+	Restricted

N	Non-Elected
I	Interference

A	Appeal
O	Objected

Claim		Date			
Final	Original	5/10/05	12/22/05	5/13/06	
	1	✓	✓	✓	
	2	✓	✓	✓	
	3	✓	✓	✓	
	4	✓	✓	✓	
	5	✓	✓	✓	
	6	✓	✓	✓	
	7	✓	✓	✓	
	8	✓	✓	✓	
	9	✓	✓	✓	
	10	✓	✓	✓	
	11	✓	✓	✓	
	12	✓	✓	✓	
	13	✓	✓	✓	
	14	✓	✓	✓	
	15	✓	✓	✓	
	16	✓	✓	✓	
	17	✓	✓	✓	
	18	✓	✓	✓	
	19	✓	✓	✓	
	20	✓	✓	✓	
	21	✓	✓	✓	
	22	✓	✓	✓	
	23	✓	✓	✓	
	24	✓	✓	✓	
	25	✓	✓	✓	
	26	✓	✓	✓	
	27	✓	✓	✓	
	28	✓	✓	✓	
	29	✓	✓	✓	
	30	✓	✓	✓	
	31	✓	✓	✓	
	32	✓	✓	✓	
	33	✓	✓	✓	
	34	✓	✓	✓	
	35	✓	✓	✓	
	36	✓	✓	✓	
	37	✓	✓	✓	
	38	✓	✓	✓	
	39	✓	✓	✓	
	40	✓	✓	✓	
	41	✓	✓	✓	
	42	✓	✓	✓	
	43	✓	✓	✓	
	44	✓	✓	✓	
	45	✓	✓	✓	
	46	✓	✓	✓	
	47	✓	✓	✓	
	48	✓	✓	✓	
	49	✓	✓	✓	
	50	✓	✓	✓	

Claim		Date			
Final	Original				
	51				
	52				
	53				
	54				
	55				
	56				
	57				
	58				
	59				
	60				
	61				
	62				
	63				
	64				
	65				
	66				
	67				
	68				
	69				
	70				
	71				
	72				
	73				
	74				
	75				
	76				
	77				
	78				
	79				
	80				
	81				
	82				
	83				
	84				
	85				
	86				
	87				
	88				
	89				
	90				
	91				
	92				
	93				
	94				
	95				
	96				
	97				
	98				
	99				
	100				

Claim		Date			
Final	Original				
	101				
	102				
	103				
	104				
	105				
	106				
	107				
	108				
	109				
	110				
	111				
	112				
	113				
	114				
	115				
	116				
	117				
	118				
	119				
	120				
	121				
	122				
	123				
	124				
	125				
	126				
	127				
	128				
	129				
	130				
	131				
	132				
	133				
	134				
	135				
	136				
	137				
	138				
	139				
	140				
	141				
	142				
	143				
	144				
	145				
	146				
	147				
	148				
	149				
	150				

**Search Notes**



Application/Control No.

10/648,012

Examiner

Andrew *Flodis*  
~~Cochran~~

Applicant(s)/Patent under Reexamination

WOOLFORK, C. EARL

Art Unit

2644

**SEARCHED**

Class	Subclass	Date	Examiner
700	94	5/10/2005	AG
714	709,780	5/10/2005	AG
706	8,9	5/10/2005	AG
455	3.06,41	5/10/2005	AG
455	66.1	5/10/2005	AG
375	224	5/10/2005	AG
381	79	12/15/2005	<i>AG</i>
455	41.3	12/15/2005	<i>AG</i>

**INTERFERENCE SEARCHED**

Class	Subclass	Date	Examiner

**SEARCH NOTES  
(INCLUDING SEARCH STRATEGY)**

	DATE	EXMR
EAST search using USPAT PGPUB DERWENT EPO JPO USOCR dbs	5/10/2005	AG
cis/sbcls at left w/ keywords Bluetooth, fuzzy, soft decision, bit energy, probability, membership, and equivalents	5/10/2005	AG
Parent application, including applied references, considered	5/10/2005	AG
Inventor search, using EAST and Internet search engine	5/10/2005	AG
381/2,455/41.2,41.3(t.o.w/low pass) 381/270(t.o.w/ headphone) various text search - see search history printout	12/15/2005	<i>AG</i>
<i>Revised + updated</i>	<i>5/21/06</i>	<i>ACF</i>



UNITED STATES PATENT AND TRADEMARK OFFICE

UNITED STATES DEPARTMENT OF COMMERCE  
United States Patent and Trademark Office  
Address: COMMISSIONER FOR PATENTS  
P.O. Box 1450  
Alexandria, Virginia 22313-1450  
www.uspto.gov

APPLICATION NUMBER	PATENT NUMBER	GROUP ART UNIT	FILE WRAPPER LOCATION
10/648,012		2615	26M1

## Correspondence Address / Fee Address Change

The following fields have been set to Customer Number 33401 on 03/14/2006

- Correspondence Address
- Maintenance Fee Address

**The address of record for Customer Number 33401 is:**  
MCDERMOTT, WILL & EMERY (LOS ANGELES OFFICE)  
2049 CENTURY PARK EAST  
34TH FLOOR  
LOS ANGELES, CA 90067-3208





UNITED STATES PATENT AND TRADEMARK OFFICE

fw

UNITED STATES DEPARTMENT OF COMMERCE  
United States Patent and Trademark Office  
Address: COMMISSIONER FOR PATENTS  
P.O. Box 1450  
Alexandria, Virginia 22313-1450  
www.uspto.gov

APPLICATION NO.	FILING DATE	FIRST NAMED INVENTOR	ATTORNEY DOCKET NO.	CONFIRMATION NO.
10/648,012	08/26/2003	C. Earl Woolfork	73785-013	3337

33401 7590 06/23/2006

MCDERMOTT, WILL & EMERY (LOS ANGELES OFFICE)  
2049 CENTURY PARK EAST  
34TH FLOOR  
LOS ANGELES, CA 90067-3208

EXAMINER

FLANDERS, ANDREW C

ART UNIT	PAPER NUMBER
2615	

2615

DATE MAILED: 06/23/2006

Please find below and/or attached an Office communication concerning this application or proceeding.

<b>Interview Summary</b>	<b>Application No.</b>	<b>Applicant(s)</b>	
	10/648,012	WOOLFORK, C. EARL	
	<b>Examiner</b>	<b>Art Unit</b>	
	Andrew C. Flanders	2615	

All participants (applicant, applicant's representative, PTO personnel):

(1) Andrew C. Flanders.

(3) Daphne Burton.

(2) Sinh Tran.

(4) C. Earl Woolfork.

Date of Interview: 13 June 2006.

Type: a)  Telephonic b)  Video Conference  
c)  Personal [copy given to: 1)  applicant 2)  applicant's representative]

Exhibit shown or demonstration conducted: d)  Yes e)  No.  
If Yes, brief description: \_\_\_\_\_.

Claim(s) discussed: 1 and 10-13.

Identification of prior art discussed: Rozin (U.S. 6,342,844, Schotz (U.S. 5,943,343) and Alstatt (U.S. 5,771,441).

Agreement with respect to the claims f)  was reached. g)  was not reached. h)  N/A.

Substance of Interview including description of the general nature of what was agreed to if an agreement was reached, or any other comments: See Continuation Sheet.

(A fuller description, if necessary, and a copy of the amendments which the examiner agreed would render the claims allowable, if available, must be attached. Also, where no copy of the amendments that would render the claims allowable is available, a summary thereof must be attached.)

THE FORMAL WRITTEN REPLY TO THE LAST OFFICE ACTION MUST INCLUDE THE SUBSTANCE OF THE INTERVIEW. (See MPEP Section 713.04). If a reply to the last Office action has already been filed, APPLICANT IS GIVEN A NON-EXTENDABLE PERIOD OF THE LONGER OF ONE MONTH OR THIRTY DAYS FROM THIS INTERVIEW DATE, OR THE MAILING DATE OF THIS INTERVIEW SUMMARY FORM, WHICHEVER IS LATER, TO FILE A STATEMENT OF THE SUBSTANCE OF THE INTERVIEW. See Summary of Record of Interview requirements on reverse side or on attached sheet.

Examiner Note: You must sign this form unless it is an Attachment to a signed Office action.

\_\_\_\_\_  
Examiner's signature, if required

## Summary of Record of Interview Requirements

### Manual of Patent Examining Procedure (MPEP), Section 713.04, Substance of Interview Must be Made of Record

A complete written statement as to the substance of any face-to-face, video conference, or telephone interview with regard to an application must be made of record in the application whether or not an agreement with the examiner was reached at the interview.

### Title 37 Code of Federal Regulations (CFR) § 1.133 Interviews Paragraph (b)

In every instance where reconsideration is requested in view of an interview with an examiner, a complete written statement of the reasons presented at the interview as warranting favorable action must be filed by the applicant. An interview does not remove the necessity for reply to Office action as specified in §§ 1.111, 1.135. (35 U.S.C. 132)

### 37 CFR §1.2 Business to be transacted in writing.

All business with the Patent or Trademark Office should be transacted in writing. The personal attendance of applicants or their attorneys or agents at the Patent and Trademark Office is unnecessary. The action of the Patent and Trademark Office will be based exclusively on the written record in the Office. No attention will be paid to any alleged oral promise, stipulation, or understanding in relation to which there is disagreement or doubt.

The action of the Patent and Trademark Office cannot be based exclusively on the written record in the Office if that record is itself incomplete through the failure to record the substance of interviews.

It is the responsibility of the applicant or the attorney or agent to make the substance of an interview of record in the application file, unless the examiner indicates he or she will do so. It is the examiner's responsibility to see that such a record is made and to correct material inaccuracies which bear directly on the question of patentability.

Examiners must complete an Interview Summary Form for each interview held where a matter of substance has been discussed during the interview by checking the appropriate boxes and filling in the blanks. Discussions regarding only procedural matters, directed solely to restriction requirements for which interview recordation is otherwise provided for in Section 812.01 of the Manual of Patent Examining Procedure, or pointing out typographical errors or unreadable script in Office actions or the like, are excluded from the interview recordation procedures below. Where the substance of an interview is completely recorded in an Examiners Amendment, no separate Interview Summary Record is required.

The Interview Summary Form shall be given an appropriate Paper No., placed in the right hand portion of the file, and listed on the "Contents" section of the file wrapper. In a personal interview, a duplicate of the Form is given to the applicant (or attorney or agent) at the conclusion of the interview. In the case of a telephone or video-conference interview, the copy is mailed to the applicant's correspondence address either with or prior to the next official communication. If additional correspondence from the examiner is not likely before an allowance or if other circumstances dictate, the Form should be mailed promptly after the interview rather than with the next official communication.

The Form provides for recordation of the following information:

- Application Number (Series Code and Serial Number)
- Name of applicant
- Name of examiner
- Date of interview
- Type of interview (telephonic, video-conference, or personal)
- Name of participant(s) (applicant, attorney or agent, examiner, other PTO personnel, etc.)
- An indication whether or not an exhibit was shown or a demonstration conducted
- An identification of the specific prior art discussed
- An indication whether an agreement was reached and if so, a description of the general nature of the agreement (may be by attachment of a copy of amendments or claims agreed as being allowable). Note: Agreement as to allowability is tentative and does not restrict further action by the examiner to the contrary.
- The signature of the examiner who conducted the interview (if Form is not an attachment to a signed Office action)

It is desirable that the examiner orally remind the applicant of his or her obligation to record the substance of the interview of each case. It should be noted, however, that the Interview Summary Form will not normally be considered a complete and proper recordation of the interview unless it includes, or is supplemented by the applicant or the examiner to include, all of the applicable items required below concerning the substance of the interview.

A complete and proper recordation of the substance of any interview should include at least the following applicable items:

- 1) A brief description of the nature of any exhibit shown or any demonstration conducted,
- 2) an identification of the claims discussed,
- 3) an identification of the specific prior art discussed,
- 4) an identification of the principal proposed amendments of a substantive nature discussed, unless these are already described on the Interview Summary Form completed by the Examiner,
- 5) a brief identification of the general thrust of the principal arguments presented to the examiner,  
(The identification of arguments need not be lengthy or elaborate. A verbatim or highly detailed description of the arguments is not required. The identification of the arguments is sufficient if the general nature or thrust of the principal arguments made to the examiner can be understood in the context of the application file. Of course, the applicant may desire to emphasize and fully describe those arguments which he or she feels were or might be persuasive to the examiner.)
- 6) a general indication of any other pertinent matters discussed, and
- 7) if appropriate, the general results or outcome of the interview unless already described in the Interview Summary Form completed by the examiner.

Examiners are expected to carefully review the applicant's record of the substance of an interview. If the record is not complete and accurate, the examiner will give the applicant an extendable one month time period to correct the record.

### Examiner to Check for Accuracy

If the claims are allowable for other reasons of record, the examiner should send a letter setting forth the examiner's version of the statement attributed to him or her. If the record is complete and accurate, the examiner should place the indication, "Interview Record OK" on the paper recording the substance of the interview along with the date and the examiner's initials.

Continuation of Substance of Interview including description of the general nature of what was agreed to if an agreement was reached, or any other comments: Discussed new matter in drawings and specification, drawings, and applied prior art. Applicant agreed to submit new drawings representing the drawings originally filed in the parent application thus overcoming the new matter rejections. Applicant explained the combination of Alstatt in view of Schotz is non-operative due to limited battery life. Applicant is going to submit evidence in an affidavit under 35 CFR 132 showing why. If the evidence is correct, the combination will no longer be applied in the rejection. Examiner and Applicant agreed to remove new matter objection in element 1 under the specification. New matter objection 2 in the specification will be corrected with the new drawings. Applicant alleges that new matter 3 objection is an inherent feature and the only way to implement under CDMA. Examiner did not agree and Applicant will submit evidence in an affidavit under 35 CFR 132 showing no other implementations are available. Applicant agreed to amend the specification to only allow for down converting thus overcoming the new matter objection in section 4 under the specification. Applicant further agreed to amend the claims to overcome the 112 rejections that could not be overcome by the submission of an affidavit under 35 USC 132. No indication of allowable subject matter was given. Further search and or consideration will be required.



**SINH TRAN**  
SUPERVISORY PATENT EXAMINER

07-17-06

ITW



PTO/SB/21 (09-04)  
Approved for use through 07/31/2006. OMB 0651-0031  
U.S. Patent and Trademark Office; U.S. DEPARTMENT OF COMMERCE

Under the Paperwork Reduction Act of 1995, no persons are required to respond to a collection of information unless it displays a valid OMB control number.

<b>TRANSMITTAL FORM</b> <small>(to be used for all correspondence after initial filing)</small>	Application Number	10/648,012
	Filing Date	August 26, 2003
	First Named Inventor	C. Earl Woolfork
	Art Unit	2615
	Examiner Name	Flanders, Andrew C
Total Number of Pages in This Submission	Attorney Docket Number	W003-4000

ENCLOSURES (Check all that apply)		
<input type="checkbox"/> Fee Transmittal Form <input type="checkbox"/> Fee Attached <input type="checkbox"/> Amendment/Reply <input type="checkbox"/> After Final <input type="checkbox"/> Affidavits/declaration(s) <input type="checkbox"/> Extension of Time Request <input type="checkbox"/> Express Abandonment Request <input type="checkbox"/> Information Disclosure Statement  <input type="checkbox"/> Certified Copy of Priority Document(s) <input type="checkbox"/> Reply to Missing Parts/ Incomplete Application <input type="checkbox"/> Reply to Missing Parts under 37 CFR 1.52 or 1.53	<input type="checkbox"/> Drawing(s) <input type="checkbox"/> Licensing-related Papers <input type="checkbox"/> Petition <input type="checkbox"/> Petition to Convert to a Provisional Application <input checked="" type="checkbox"/> Power of Attorney, Revocation <input type="checkbox"/> Change of Correspondence Address <input type="checkbox"/> Terminal Disclaimer <input type="checkbox"/> Request for Refund <input type="checkbox"/> CD, Number of CD(s) _____ <input type="checkbox"/> Landscape Table on CD	<input type="checkbox"/> After Allowance Communication to TC <input type="checkbox"/> Appeal Communication to Board of Appeals and Interferences <input type="checkbox"/> Appeal Communication to TC (Appeal Notice, Brief, Reply Brief) <input type="checkbox"/> Proprietary Information <input type="checkbox"/> Status Letter <input type="checkbox"/> Other Enclosure(s) (please identify below):
Remarks Sent by Express Mail Express Mail Label No.: ET615079119US		

SIGNATURE OF APPLICANT, ATTORNEY, OR AGENT		
Firm Name	The Patel Law Firm, P.C.	
Signature		
Printed name	Natu J. Patel	
Date	7/15/06	Reg. No. 39,559

CERTIFICATE OF TRANSMISSION/MAILING		
I hereby certify that this correspondence is being facsimile transmitted to the USPTO or deposited with the United States Postal Service with sufficient postage as first class mail in an envelope addressed to: Commissioner for Patents, P.O. Box 1450, Alexandria, VA 22313-1450 on the date shown below:		
Signature		
Typed or printed name	Natu J. Patel	Date 7/15/06

This collection of information is required by 37 CFR 1.5. The information is required to obtain or retain a benefit by the public which is to file (and by the USPTO to process) an application. Confidentiality is governed by 35 U.S.C. 122 and 37 CFR 1.11 and 1.14. This collection is estimated to 2 hours to complete, including gathering, preparing, and submitting the completed application form to the USPTO. Time will vary depending upon the individual case. Any comments on the amount of time you require to complete this form and/or suggestions for reducing this burden, should be sent to the Chief Information Officer, U.S. Patent and Trademark Office, U.S. Department of Commerce, P.O. Box 1450, Alexandria, VA 22313-1450. DO NOT SEND FEES OR COMPLETED FORMS TO THIS ADDRESS. SEND TO: Commissioner for Patents, P.O. Box 1450, Alexandria, VA 22313-1450.

If you need assistance in completing the form, call 1-800-PTO-9199 and select option 2.



Under the Paperwork Reduction Act of 1995, no persons are required to respond to a collection of information unless it displays a valid OMB control number.

**POWER OF ATTORNEY  
 and  
 CORRESPONDENCE ADDRESS  
 INDICATION FORM**

Application Number	10/648,012
Filing Date	August 26, 2003
First Named Inventor	C. Earl Woolfork
Title	WIRELESS DIGITAL AUDIO MUSIC SYSTEM
Art Unit	2615
Examiner Name	Flanders, Andrew C
Attorney Docket Number	W003-4000

I hereby revoke all previous powers of attorney given in the above-identified application.

I hereby appoint:

Practitioners associated with the Customer Number:

OR

Practitioner(s) named below:

Name	Registration Number
Natu J. Patel	39,559

as my/our attorney(s) or agent(s) to prosecute the application identified above, and to transact all business in the United States Patent and Trademark Office connected therewith.

Please recognize or change the correspondence address for the above-identified application to:

The address associated with the above-mentioned Customer Number:

OR

The address associated with Customer Number:

<input checked="" type="checkbox"/> Firm or Individual Name	The Patel Law Firm, P.C.		
Address	2532 Dupont Drive		
City	Irvine	State	California
		Zip	92612
Country	USA		
Telephone	949-955-1077	Email	NPatel@thePatelLawFirm.com

I am the:

Applicant/Inventor.

Assignee of record of the entire interest. See 37 CFR 3.71.

Statement under 37 CFR 3.73(b) is enclosed. (Form PTO/SB/96)

**SIGNATURE of Applicant or Assignee of Record**

Signature		Date	7-12-06
Name	C. Earl Woolfork	Telephone	818-625-4966
Title and Company	One- E-Way, Inc.		

NOTE: Signatures of all the Inventors or assignees of record of the entire interest or their representative(s) are required. Submit multiple forms if more than one signature is required, see below.

Total of \_\_\_\_\_ forms are submitted.

This collection of information is required by 37 CFR 1.31, 1.32 and 1.33. The information is required to obtain or retain a benefit by the public which is to file (and by the USPTO to process) an application. Confidentiality is governed by 35 U.S.C. 122 and 37 CFR 1.11 and 1.14. This collection is estimated to take 3 minutes to complete, including gathering, preparing, and submitting the completed application form to the USPTO. Time will vary depending upon the individual case. Any comments on the amount of time you require to complete this form and/or suggestions for reducing this burden, should be sent to the Chief Information Officer, U.S. Patent and Trademark Office, U.S. Department of Commerce, P.O. Box 1450, Alexandria, VA 22313-1450. DO NOT SEND FEES OR COMPLETED FORMS TO THIS ADDRESS. SEND TO: Commissioner for Patents, P.O. Box 1460, Alexandria, VA 22313-1450.

If you need assistance in completing the form, call 1-800-PTO-9199 and select option 2.



UNITED STATES PATENT AND TRADEMARK OFFICE

UNITED STATES DEPARTMENT OF COMMERCE  
United States Patent and Trademark Office  
Address: COMMISSIONER FOR PATENTS  
P.O. Box 1450  
Alexandria, Virginia 22313-1450  
www.uspto.gov

APPLICATION NUMBER	FILING OR 371 (c) DATE	FIRST NAMED APPLICANT	ATTY. DOCKET NO./TITLE
10/648,012	08/26/2003	C. Earl Woolfork	73785-013

CONFIRMATION NO. 3337

33401  
MCDERMOTT, WILL & EMERY (LOS ANGELES OFFICE)  
2049 CENTURY PARK EAST  
34TH FLOOR  
LOS ANGELES, CA 90067-3208



Date Mailed: 07/31/2006

**NOTICE REGARDING CHANGE OF POWER OF ATTORNEY**

This is in response to the Power of Attorney filed 07/15/2006.

- The Power of Attorney to you in this application has been revoked by the applicant. Future correspondence will be mailed to the new address of record(37 CFR 1.33).

---

*WTS*  
WUBALEM TSIGE  
PTOSS (703) 305-3006

OFFICE COPY



UNITED STATES PATENT AND TRADEMARK OFFICE

UNITED STATES DEPARTMENT OF COMMERCE  
United States Patent and Trademark Office  
Address: COMMISSIONER FOR PATENTS  
P.O. Box 1450  
Alexandria, Virginia 22313-1450  
www.uspto.gov

APPLICATION NUMBER	FILING OR 371 (c) DATE	FIRST NAMED APPLICANT	ATTY. DOCKET NO./TITLE
10/648,012	08/26/2003	C. Earl Woolfork	W003-4000

CONFIRMATION NO. 3337

The Patel Law Firm, P.C.  
2532 Dupont Drive  
Irvine, CA 92612



Date Mailed: 07/31/2006

**NOTICE OF ACCEPTANCE OF POWER OF ATTORNEY**

This is in response to the Power of Attorney filed 07/15/2006.

The Power of Attorney in this application is accepted. Correspondence in this application will be mailed to the above address as provided by 37 CFR 1.33.



*WTS*  
WUBALEM TSI  
PTOSS (703) 305-3006

OFFICE COPY



Application Serial No. 10/648,012  
Response to Office Action of May 17, 2006  
Attorney Docket No. W003-4000



**CERTIFICATE OF EXPRESS MAIL**

---

I hereby certify that this paper (along with any paper referred to as being attached or enclosed) is being deposited with the United States Postal Service on the date shown below with sufficient postage via EXPRESS MAIL in an envelope addressed as follows

**(Express Mail Label No.: ET615079096US):**

Mail Stop AMENDMENT  
Commissioner for Patents  
Post Office Box 1450  
Alexandria, Virginia 22313-1450

---

Natu J. Patel, USPTO Reg. No. 39,559

Date: August 15, 2006

Application Serial No. 10/648,012  
Response to Office Action of May 17, 2006  
Attorney Docket No. W003-4000



(Express Mail Label No.: ET615079096US)

**IN THE UNITED STATES PATENT AND TRADEMARK OFFICE**

---

Application No.: 10/648,012  
Applicant: WOOLFORK, C. Earl  
Filing Date: 08/26/2003  
Title: WIRELESS DIGITAL AUDIO MUSIC SYSTEM  
TC/A.U.: 2615  
Confirmation No. 3337  
Examiner: FLANDERS, Andrew C.  
Docket No. W003-4000

---

Mail Stop AMENDMENT  
Commissioner for Patents  
Post Office Box 1450  
Alexandria, Virginia 22313-1450

**RESPONSE TO OFFICE ACTION**

Dear Sir:

In response to the Office Action of May 17, 2006, please amend without prejudice the above-identified patent application as follows:

**Amendments to the Specification** begin on page 2 of this paper.

**Amendments to the Drawings** begin on page 11 of this paper.

**Amendments to the Claims** are reflected in the listing of claims, which begins on page 12 of this paper.

**Remarks/Arguments** begin on page 36 of this paper.

08/17/2006 WARDLR1 00000067 10648012

01 FC:2201 1100.00 DP  
02 FC:2202 1000.00 DP

**Amendments to the Specification:**

Please amend the title of the invention on page 1 as follows:

--WIRELESS DIGITAL AUDIO MUSIC SYSTEM --

Please amend the paragraph which begins on page 1, line 2 and ends on page 1, line 3, as follows:

-- This utility patent application is a continuation-in-part of U.S. patent application Serial No. 10/027,391, filed December 21, 2001, for "Wireless Digital Audio System," published under US 2003/0118196 A1 on June 26, 2003, now abandoned, which is incorporated herein in its entirety by reference which patent application is pending.--

Please amend paragraph [0005] as follows:

-- The present invention is generally directed to a wireless digital audio music system for coded digital transmission of an analog audio signal from any music audio player device with an analog headphone jack to a receiver headphone located away from the audio player. Fuzzy logic technology may be utilized by the wireless digital audio music system to enhance bit detection. A battery-powered transmitter may include a headphone plug in communication with any of the previously mentioned suitable music audio source[[s]]. For reception, a battery-powered headphone receiver may apply use embedded fuzzy logic to enhance user code bit detection. Fuzzy logic detection may be used to enhance user code bit detection during decoding of the transmitted audio signal. The wireless digital audio music system [[will]] provides private listening without

interference from other users or wireless devices and without the use of [[wires]]  
conventional cable connections.--

Please amend paragraph [0007] as follows:

--Some aspects of the present invention are generally shown by way of reference  
to the accompanying drawings in which:

Figure 1 schematically illustrates a schematic diagram representation of the  
wireless digital audio music system according to and embodiment of in accordance with  
the present [[the]] invention;

Figure 2 is a block illustrates a schematic diagram representation of [[the]] an  
audio transmitter portion of the wireless digital audio system of Fig. 1 according to an  
embodiment of the invention;

Figure 3 illustrates a schematic diagram representation of the receiver without the  
use of the fuzzy logic enhancement according to an embodiment of the invention is a  
block diagram of an audio receiver portion of the wireless digital audio system of Fig. 1;  
and

Figure 4 illustrates a schematic diagram representation of the system with the use  
of the fuzzy logic enhancement is an exemplary graph showing the utilization of an  
embedded fuzzy logic coding algorithm according to [[an]] one embodiment of the  
present invention.--

Please amend paragraph [0009] as follows:

--Referring to Figures 1 through 3, a wireless digital audio music system 10 may include a battery powered transmitter 20 connected to a portable music audio player or music audio source 80. The battery powered wireless digital audio music transmitter 20 [[that]] utilizes an analog to digital converter or ADC 32 and may be connected to the music audio source 80 analog headphone jack 82 using a headphone plug 22. The battery powered transmitter 20 may have a transmitting antenna 24 that may be omni-directional for transmitting a spread spectrum modulated signal to a receiving antenna 52 of a battery powered headphone receiver 50. The battery powered receiver 50 may have headphone speakers 75[[4]] in headphones 55 for listening to the spread spectrum demodulated and decoded communication signal. In the headphone receiver 50, fuzzy logic detection may be used to optimize reception of the received user code. The transmitter 20 may digitize the audio signal using [[an]] ADC 32. The digitized signal [[that]] may be ~~in communication with~~ processed downstream by an encoder 36. After digital conversion, the digital signal may be processed by a digital low pass filter. To reduce the effects of channel noise, the battery powered transmitter 20 may use a channel encod[[ing]]er 38. A modulator 4[[8]]2 modulates the digital signal to be transmitted. For further noise immunity, a spread spectrum modulation DPSK (differential phase shift key) transmitter or module 4[[2]]8 is utilized. The battery powered transmitter 20 may contain a code generator 44 that may be used to create a unique user code. The unique user code generated is specifically associated with one wireless digital audio music system user, and it is the only code recognized by the battery powered headphone receiver 50 operated by a particular user. The radio frequency (RF) spectrum utilized (as taken from the

Industrial, Scientific and Medical (ISM) band)[[.]] may be approximately 2.4 GHz. ~~And~~  
~~the~~ The power radiated by the transmitter adheres to the ISM standard.--

Please amend paragraph [0010] as follows:

~~--A digital signal may be received at antenna receiving antenna 52 and~~  
~~communicated to, e.g., a wideband bandpass filter. [[The]]~~ Particularly, the received  
spread spectrum signal may [[then]] be communicated to a 2.4 GHz direct conversion  
receiver or module 56. A frequency shift keying (FSK) modulation/detection technique  
could be used given a frequency hopping spread spectrum (FHSS) system choice. ~~The~~  
~~direct conversion receiver 56 may provide a means to convert the received signal using~~  
~~timing and synchronization to capture the correct bit sequence embedded in the received~~  
~~spread spectrum signal. Referring to Figures 1 through 4, the spread spectrum modulated~~  
signal from transmit antenna 24 may be received by receiving antenna 52 and then  
processed by spread spectrum demodulated direct conversion receiver or module 56[[2]]  
with a receiver code generator 60 that contains the same transmitted unique code, in the  
battery powered receiver 50 headphones. The transmitted signal from ~~transmit~~ antenna  
24 may be received by receiving antenna 52 and communicated to a wideband bandpass  
filter (BPF). ~~The received digital signal may be processed by a demodulator 58 (Figure~~  
3). The battery powered receiver 50 may utilize embedded fuzzy logic [[61]] (as best  
viewed graphically depicted in Figures 1, 4) to optimize the bit detection of the received  
user code. The down converted output signal of direct conversion receiver or module 56  
may be summed in receiver summing element 58 with a receiver code generator 60  
signal. The receiver code generator 60 may contain the same unique wireless

transmission of a signal code word that was transmitted by audio transmitter 20 specific to a particular user. Other code words from wireless digital audio systems 10 may appear as noise to audio receiver 50. This may also be true for wireless signals operating in the wireless digital audio spectrum of digital audio system 10. This code division multiple access (CDMA) may be used to provide each user independent audible enjoyment. The resulting summed digital signal from receiving summary element 58 may be processed by a 64-Ary demodulator 62 to demodulate the signal elements modulated in the audio transmitter 20. A block de-interleaver 64 may then decode the bits of the digital signal encoded in the block interleaver 40. Following such, a Viterbi decoder 66 may be used to decode the bits encoded by channel encoder 38 in audio transmitter 20. A source decoder 68 may further decode the coding applied by encoder 36.

Please amend paragraph [0013] as follows:

-- The user code bits in each packet may also be received and detected by a fuzzy logic detection [[61]] sub-system 61 (as an option) embedded in [[the]] head[[set]]phone receiver 50 to ~~provide additional~~ optimize audio receiver performance. For each consecutive packet received, [[the]] fuzzy logic detection sub-system 61 may compute a conditional density with respect to the context and fuzziness of the user code vector, i.e., the received code bits in each packet. Fuzziness may describe the ambiguity of the high bit (1)/low bit (0 or -1) [[bit]] event in the received user code within the packet. The fuzzy logic detection sub-system 61 may measure the degree to which a high/low bit occurs in the user code vector, which produces a low probability of bit error in the presence of noise. The fuzzy logic detection sub-system 61 may use a set of if-then rules

to map the user code bit inputs to validation outputs. These rules may be developed as if-then statements ~~[[61]]~~.

Please amend paragraph ~~[0014]~~ as follows:

~~[[The]]~~ ~~[[f]]~~ Fuzzy logic detection sub-system 61 in ~~[[the]]~~ battery-powered headphone receiver 50 utilizes the if-then fuzzy set to map the received user code bits into two values~~[[;]]~~: a low (0 or -1) and a high (1). Thus, as the user code bits are received, the "if" rules map the signal bit energy to the fuzzy set low value to some degree and to the fuzzy set high value to some degree. ~~See Figure 4 schematic block 61.~~ ~~Figure 4 schematic block 61~~ graphically shows that x-value -1 equals the maximum low bit energy representation and x-value 1 equals the maximum high bit energy representation. Due to additive noise, the user code bit energy may have some membership to low and high as represented in ~~[[61]]~~ ~~[[of]]~~ Figure 4. The if-part fuzzy set may determine if each bit in the user code, for every received packet, has a greater membership to a high bit representation or a low bit representation. The more a user code bit energy fits into the high or low representation, the closer its subsethood, i.e., a measure of the membership degree to which a set may be a subset of another set, may be to one.

Please amend paragraph ~~[0015]~~ as follows:

~~[[The]]~~ if-then rule parts that make up the fuzzy logic detection sub-system 61 must be followed by a defuzzifying operation. This operation reduces the aforementioned fuzzy set to a bit energy representation (i.e., -1 or 1) that is received by the transmitted



packet. ~~[[The]]~~ ~~[[f]]~~ Fuzzy logic detection sub-system 61 may be used in ~~[[the]]~~ battery-powered head~~[[set]]~~phone receiver 50 to enhance overall system ~~[[10]]~~ performance.--

Please amend paragraph [0016] as follows:

~~--The channel decoder 66 may be a Viterbi decoder. A channel decoder 66 may be in communication with the bandpass filter. A decoder 68 may be in communication with a digital to analog converter or DAC 70 that may convert the digital signal back to an analog audio music signal. The next step may process the digital signal to return the signal to analog or base band format for use in powering speaker(s) 75. A digital-to-analog converter 70 (DAC) may be used to transform the digital signal to an analog audio signal. An analog low pass filter 72 may be used to filter the analog audio music signal to pass a signal in the approximate 20 Hz to 20 kHz frequency range and filter other frequencies. The analog audio music signal may then be processed by a power amplifier 74 that may be optimized [[to]] for powering headphone speakers 75[[4]] to optimize provide a high quality, low distortion audio music signal for hearing audible enjoyment by a user wearing [[the]] headphones 55. A person skilled in the art would appreciate that some of the embodiments described hereinabove are merely illustrative of the general principles of the present invention. Other modifications or variations may be employed that are within the scope of the invention. Thus, by way of example, but not of limitation, alternative configurations may be utilized in accordance with the teachings herein. Accordingly, the drawings and description are illustrative and not meant to be a limitation thereof.--~~

Please amend paragraph [0017] as follows:

~~--While the invention has been particularly shown and described with respect to the illustrated and preferred embodiments thereof, it will be understood by those skilled in the art that the foregoing and other changes in form and details may be made therein without departing from the spirit and scope of the invention. Moreover, all terms should be interpreted in the broadest possible manner consistent with the context. In particular, the terms "comprises" and "comprising" should be interpreted as referring to elements, components, or steps in a non-exclusive manner, indicating that the referenced elements, components, or steps may be present, or utilized, or combined with other elements, components, or steps that are not expressly referenced. Thus, it is intended that the invention cover all embodiments and variations thereof as long as such embodiments and variations come within the scope of the appended claims and their equivalents.--~~

Please amend paragraph [0018] as follows:

~~--[0017] The A wireless digital audio music system includes a portable audio source with a digital audio transmitter operatively coupled thereto and an audio receiver operatively coupled to a headphone set. The audio receiver is configured for digital wireless communication with the audio transmitter. The digital audio receiver utilizes fuzzy logic to optimize digital signal processing. Each of the digital audio transmitter and receiver is configured for code division multiple access (CDMA) communication. may utilize a battery powered transmitter to transmit a coded digital signal from an existing analog headphone jack of a music audio player device or source to a battery powered headphone receiver without the use of wires. A battery powered digital transmitter may~~

~~include a headphone plug in communication with a standard analog headphone jack on an audio source, such as, laptop and desktop computers, portable compact disc players, portable MP3 players, portable cassette players, etc. The battery powered transmitter adds a unique user code and transmits it to the battery powered receiver headphones where a fuzzy logic detection system may be used to enhance decoding performance. The wireless digital audio system [[will]] allows private listening audio enjoyment without interference from other users or other wireless devices, and without the inconvenience of wires.--~~

This listing of claims will replace all prior versions, and listings, of claims in the application.

**Listing of Claims:**

Claim 1 (Previously Presented). A wireless digital audio music system for spread spectrum communication of an audio music signal from the analog headphone jack connected to a battery powered spread spectrum transmitter and received by a battery powered spread spectrum headphone receiver comprising:

an analog headphone jack from an analog audio music source in communication with a battery powered digital transmitter;

said battery powered digital transmitter converts an analog audio music signal from said existing analog headphone jack to a digital signal using an ADC in communication with an encoder;

said encoder in communication with a channel encoder;

said channel encoder in communication with a digital modulator;

said digital modulator in communication with a spread spectrum communication modulator that utilizes a code generator to create a unique hop pattern for each individual user;

said spread spectrum communication modulator in communication with a transmit antenna that transmits at a radio frequency of approximately 2.4 GHz for receipt by a receiving antenna;

said receiving antenna in communication with a spread spectrum communication demodulator;

said spread spectrum communication demodulator in communication with a receiver code generator and with a digital demodulator;

said digital demodulator in communication with a channel decoder;

said channel decoder in communication with a receiver decoder;

said receiver decoder in communication with a DAC;

said DAC in communication with a low pass filter to pass the analog music signal in the approximate frequency band of 20 Hz to 20 kHz; and

said low pass filter passing analog music signal will be amplified for processing to a speaker headphone set to provide high quality music for listening by a single user wearing the headphones.

Claims 2 – 3 (canceled).

Claim 4 (Previously Presented). A method for battery powered wireless communication transmission and reception of high fidelity audio music between a battery operated digital transmitter and a battery operated digital receiver headphone comprising the steps of:

connecting the plug attached to said battery operated digital transmitter to the existing analog headphone jack of an audio music source;

converting a music audio signal to a digital communication signal using an ADC in communication with an encoder;

encoding the communication signal using channel encoding;

modulating the digital communication signal using a digital modulator;

creating a spread spectrum signal using a code generator to modulate a unique hop pattern for each individual user;

transmitting said spread spectrum signal at a radio frequency of approximately 2.4 GHz;

receiving said spread spectrum signal at said battery operated receiver headphones;

demodulating said spread spectrum signal;

demodulating said digital communication signal;

channel decoding of said digital communication signal;

converting said digital communication signal back to said analog music audio signal using a decoder in communication with a DAC; and

communicating said analog music audio signal to a headphone speaker within the headphone receiver.

Claim 5 (canceled).

Claim 6 (Previously Presented). An audio music digital wireless transmitter for spread spectrum communication of an audio music signal, comprising:

an analog headphone jack from an audio music source in communication with a battery powered digital transmitter;

said battery powered digital transmitter being configured to convert an analog audio music signal from said existing analog headphone jack to a digital signal using an ADC in communication with an encoder;

said encoder in communication with a channel encoder;  
said channel encoder in communication with a digital modulator;  
said digital modulator in communication with a spread spectrum communication modulator that utilizes a code generator to create a unique hop pattern for each individual user; and  
said spread spectrum communication modulator in communication with a transmit antenna that transmits at a radio frequency of approximately 2.4 GHz for receipt by a receiving antenna.

Claim 7 (Previously Presented). An audio music digital wireless receiver for spread spectrum communication of an audio music signal, comprising:

a receiving antenna in communication with a spread spectrum communication demodulator;  
said spread spectrum communication demodulator in communication with a code generator configured to create a unique hop pattern for each individual user;  
said digital demodulator in communication with a channel decoder;  
said channel decoder in communication with a decoder;  
said decoder in communication with a DAC;  
said DAC in communication with a low pass filter to pass the analog music signal in the approximate frequency band of 20 Hz to 20kHz; and  
said low pass filter passing analog music signal will be amplified for processing to a speaker headphone set to provide high quality music for listening by a single user wearing the headphones.

Claims 8 – 9 (canceled).

Claim 10 (Previously Presented). A wireless digital audio music system for spread spectrum communication of an audio music signal from the analog headphone jack connected to a battery powered spread spectrum transmitter and received by a battery powered spread spectrum headphone receiver comprising:

an analog headphone jack from an audio music source in communication with a battery powered digital transmitter;

said battery powered digital transmitter converts an analog audio music signal from said existing analog headphone jack to a digital signal using an ADC in communication with an encoder;

said encoder in communication with a channel encoder that is configured to send encoded symbols that are compatible with a Viterbi decoder;

said channel encoder in communication with [a digital low pass filter;

said digital low pass filter in communication with] a digital modulator;

said digital modulator in communication with a spread spectrum communication modulator that utilizes a code generator to create a unique hop pattern for each individual user;

said spread spectrum communication modulator in communication with a transmit antenna that transmits at a radio frequency of approximately 2.4 GHz for receipt by a receiving antenna;

said receiving antenna in communication with a spread spectrum communication demodulator;



said spread spectrum communication demodulator in communication with a receiver code generator and with a digital demodulator;

said digital demodulator in communication with a Viterbi decoder;

said Viterbi decoder in communication with a receiver decoder;

said receiver decoder in communication with a DAC;

said DAC in communication with a low pass filter to pass the analog music signal in the approximate frequency band of 20 Hz to 20 kHz; and

said low pass filter passing analog music signal will be amplified for processing to a speaker headphone set to provide high quality music for listening by a single user wearing the headphones.

Claim 11 (Previously Presented). An audio music digital wireless receiver for spread spectrum communication of an audio music signal to be received by a battery powered spread spectrum headphone receiver comprising:

a receiving antenna in communication with a spread spectrum communication demodulator;

said spread spectrum communication demodulator in communication with a code generator configured to create a unique hop pattern for each individual user;

said digital demodulator in communication with a Viterbi decoder;

said Viterbi decoder in communication with a decoder;

said decoder in communication with a DAC;

said DAC in communication with a low pass filter to pass the analog music signal in the approximate frequency band of 20 Hz to 20kHz; and

said low pass filter passing analog music signal will be amplified for processing to a speaker headphone set to provide high quality music for listening by a single user wearing the headphones.

Claim 12 (Currently Amended). A wireless digital audio music system for spread spectrum communication of an audio music signal from the analog headphone jack connected to a battery powered spread spectrum transmitter and received by a battery powered spread spectrum headphone receiver comprising:

an analog headphone jack from an audio music source in communication with a battery powered digital transmitter;

said battery powered digital transmitter converts an audio music signal from said existing analog headphone jack to a digital signal using an ADC in communication with an encoder;

said encoder in communication with a channel encoder;

said channel encoder in communication with a digital modulator;

said digital modulator in communication with a spread spectrum communication modulator that utilizes a code generator to create a unique hop pattern for an individual user;

said spread spectrum communication modulator in communication with a transmit antenna that transmits at a radio frequency of approximately 2.4 GHz for receipt by a receiving antenna;

said receiving antenna in communication with a spread spectrum communication demodulator;

a receiver code generator configured to create a unique hop pattern for each individual user;

a 2.4 GHz direct conversion receiver that includes a spread spectrum communication demodulator ~~and a receiver code generator;~~

said spread spectrum communication demodulator in communication with said receiver code generator and with a digital demodulator;

said digital demodulator in communication with a channel decoder;

said channel decoder in communication with a receiver decoder;

said receiver decoder in communication with a DAC;

said DAC in communication with a low pass filter to pass the analog music signal in the approximate frequency band of 20 Hz to 20 kHz; and

said low pass filter passing analog music signal will be amplified for processing to a speaker headphone set to provide high quality music for listening by a single user wearing the headphones.

Claim 13 (Previously Presented). An audio music digital wireless receiver for spread spectrum communication of an audio music signal, comprising:

a receiving antenna in communication with a 2.4 GHz direct conversion receiver, wherein the direct conversion receiver includes a spread spectrum communication demodulator in communication with a code generator, said code generator being configured to create a unique hop pattern for each individual user;

said digital demodulator in communication with a channel decoder;

said channel decoder in communication with a decoder;

said decoder in communication with a DAC;

said DAC in communication with a low pass filter to pass the analog music signal in the approximate frequency band of 20 Hz to 20kHz; and

said low pass filter passing analog music signal will be amplified for processing to a speaker headphone set to provide high quality music for listening by a single user wearing the headphones.

Claim 14 (new). A wireless digital audio system, comprising:

at least one audio source;

at least one digital audio transmitter operatively coupled to said at least one audio source;

at least one audio receiver adapted for digital wireless communication with said at least one audio transmitter and utilizing fuzzy logic to optimize digital signal processing, each of said at least one digital audio transmitter and receiver being configured for code division multiple access (CDMA) communication; and

at least one module adapted to audibly reproduce said processed CDMA signal, said CDMA communication configuration providing a user with independent audio reproduction free of interference from other users or wireless devices.

Claim 15 (new). A wireless digital audio system, comprising:

at least one audio source;

at least one digital audio transmitter operatively coupled to said at least one audio source;

at least one audio receiver adapted for digital wireless communication with said at least one audio transmitter and utilizing fuzzy logic to optimize digital signal processing, each of said at least one digital audio transmitter and receiver being configured for code division multiple access (CDMA) communication;

at least one module adapted to amplify said processed CDMA signal; and

at least one module adapted to audibly reproduce said amplified signal, said CDMA communication configuration providing a user with independent audio reproduction free of interference from other users or wireless devices.

Claim 16 (new). The wireless digital audio system of Claim 15, wherein said at least one signal amplifying module includes at least one power amplifier, said at least one power amplifier being configured to provide a low distortion audio signal output.

Claim 17 (new). The wireless digital audio system of Claim 16, wherein said at least one audible reproducing module includes at least one headphone speaker, said at least one headphone speaker receiving said low distortion audio signal output from said at least one power amplifier.

Claim 18 (new). The wireless digital audio system of Claim 14, wherein said at least one audible reproducing module includes at least one headphone speaker.

Claim 19 (new). A wireless digital audio system, comprising:

at least one audio source;

at least one digital audio transmitter operatively coupled to said at least one audio source, said at least one audio transmitter comprising:

a first analog low pass filter receiving audio output from said at least one audio source;

a digital low pass filter;

an analog-to-digital converter (ADC) operatively coupled between said first analog and digital low pass filters;

a first encoder receiving output from said digital low pass filter and being configured to reduce intersymbol interference (ISI);

a second channel encoder operatively coupled to said first encoder and adapted to reduce transmission errors;

a digital modulator operatively coupled to said second channel encoder;  
and

a differential phase shift key (DPSK) module receiving output from said digital modulator and being configured for direct sequence spread spectrum (DSSS) communication, said DPSK module transmitting a corresponding DSSS signal;

at least one audio receiver configured for digital wireless communication with said at least one audio transmitter and utilizing embedded fuzzy logic to optimize digital signal processing, said at least one audio receiver comprising:

a band pass filter (BPF) configured to process said transmitted DSSS signal;

a direct conversion module receiving output from said BPF and being configured to capture the correct bit sequence embedded in said processed DSSS signal;

a digital demodulator adapted to process output from said direct conversion module;

a Viterbi decoder operatively coupled to said digital demodulator and generating a corresponding digital output;

a source decoder processing said digital output from said Viterbi decoder and being configured to decode the digital signal encoded by said first encoder;

a second analog low pass filter; and

a digital-to-analog converter (DAC) operatively coupled between said source decoder and said second analog low pass filter, said second analog low pass filter generating an audio output corresponding to the decoded and converted digital signal; and

at least one module adapted to reproduce said generated audio output, said audio output having been wirelessly transmitted from said at least one audio source to a user without interference from other users or wireless devices.

Claim 20 (new). The wireless digital audio system of Claim 19, wherein said BPF is a wideband BPF.

Claim 21 (new). The wireless digital audio system of Claim 19, wherein said modulator is a 64-Ary modulator.

Claim 22 (new). The wireless digital audio system of Claim 19, wherein said demodulator is a 64-Ary demodulator.

Claim 23 (new). The wireless digital audio system of Claim 19, wherein said generated audio output is in the approximate range of 20 Hz to 20 kHz.

Claim 24 (new). The wireless digital audio system of Claim 19, wherein said spread spectrum signal is transmitted at about 2.4 GHz via an omni-directional antenna.

Claim 25 (new). The wireless digital audio system of Claim 24, wherein said spread spectrum signal is transmitted at a power of about 100 milliwatts or less.

Claim 26 (new). The wireless digital audio system of Claim 19, wherein said ADC is a 4-bit analog-to-digital converter.

Claim 27 (new). The wireless digital audio system of Claim 19, wherein said at least one audio source is a portable audio player.

Claim 28 (new). The wireless digital audio system of Claim 19, wherein said at least one audio reproducing module includes at least one headphone speaker.

Claim 29 (new). The wireless digital audio system of Claim 19, wherein said BPF is operatively coupled to at least one antenna configured to receive said transmitted DSSS signal.



Claim 30 (new). A wireless digital audio system, comprising:

at least one audio source;

at least one digital audio transmitter operatively coupled to said at least one audio source, said at least one audio transmitter comprising:

a first analog low pass filter receiving audio output from said at least one audio source;

a digital low pass filter;

an analog-to-digital converter (ADC) operatively coupled between said first analog and digital low pass filters;

a first encoder receiving output from said digital low pass filter and being configured to reduce intersymbol interference (ISI);

a second channel encoder operatively coupled to said first encoder and adapted to reduce transmission errors;

a digital modulator operatively coupled to said second channel encoder;  
and

a differential phase shift key (DPSK) module receiving output from said digital modulator and being configured for direct sequence spread spectrum (DSSS) communication, said DPSK module transmitting a corresponding DSSS signal;

at least one audio receiver configured for digital wireless communication with said at least one audio transmitter and utilizing embedded fuzzy logic to optimize digital signal processing, said at least one audio receiver comprising:

a band pass filter (BPF) configured to process said transmitted DSSS signal;

a direct conversion module receiving output from said BPF and being configured to capture the correct bit sequence embedded in said processed DSSS signal;

a digital demodulator adapted to process output from said direct conversion module;

a Viterbi decoder operatively coupled to said digital demodulator and generating a corresponding digital output;

a source decoder processing said digital output from said Viterbi decoder and being configured to decode the digital signal encoded by said first encoder;

a second analog low pass filter; and

a digital-to-analog converter (DAC) operatively coupled between said source decoder and said second analog low pass filter, said second analog low pass filter generating an audio output corresponding to the decoded and converted digital signal;

at least one module adapted to amplify said generated audio output; and

at least one module adapted to reproduce said amplified audio output, said audio output having been wirelessly transmitted from said at least one audio source to a user without interference from other users or wireless devices.

Claim 31 (new). The wireless digital audio system of Claim 30, wherein said at least one audio amplifying module includes at least one power amplifier, said at least one power amplifier being configured to provide a low distortion audio signal output.

Claim 32 (new). The wireless digital audio system of Claim 31, wherein said at

least one audio reproducing module includes at least one headphone speaker, said at least one headphone speaker receiving said low distortion audio signal output from said at least one power amplifier.

Claim 33 (new). A wireless digital audio system, comprising:

at least one audio source;

at least one digital audio transmitter operatively coupled to said at least one audio source;

at least one audio receiver adapted for digital wireless communication with said at least one audio transmitter, each of said at least one digital audio transmitter and receiver being configured for code division multiple access (CDMA) communication; and

at least one module adapted to audibly reproduce said processed CDMA signal, said CDMA communication configuration providing a user with independent audio reproduction free of interference from other users or wireless devices.

Claim 34 (new). A wireless digital audio system, comprising:

at least one audio source;

at least one digital audio transmitter operatively coupled to said at least one audio source;

at least one audio receiver adapted for digital wireless communication with said at least one audio transmitter, each of said at least one digital audio transmitter and receiver being configured for code division multiple access (CDMA) communication;

at least one module adapted to amplify said processed CDMA signal; and

at least one module adapted to audibly reproduce said amplified signal, said CDMA communication configuration providing a user with independent audio reproduction free of interference from other users or wireless devices.

Claim 35 (new). The wireless digital audio system of Claim 14, wherein said at least one audio source provides analog output in the approximate range of 20 Hz to 20 kHz.

Claim 36 (new). The wireless digital audio system of Claim 15, wherein said at least one audio source provides analog output in the approximate range of 20 Hz to 20 kHz.

Claim 37 (new). The wireless digital audio system of Claim 33, wherein said at least one audio source provides analog output in the approximate range of 20 Hz to 20 kHz.

Claim 38 (new). The wireless digital audio system of Claim 34, wherein said at least one audio source provides analog output in the approximate range of 20 Hz to 20 kHz.

Claim 39 (new). The wireless digital audio system of Claim 14, wherein at least one of said digital audio transmitter and receiver is battery-powered.

Claim 40 (new). The wireless digital audio system of Claim 15, wherein at least one of said digital audio transmitter and receiver is battery-powered.

Claim 41 (new). The wireless digital audio system of Claim 33, wherein at least one of said digital audio transmitter and receiver is battery-powered.

Claim 42 (new). The wireless digital audio system of Claim 34, wherein at least one of said digital audio transmitter and receiver is battery-powered.

Claim 43 (new). A wireless digital audio system, comprising:

at least one audio source;

at least one digital audio transmitter operatively coupled to said at least one audio source, said at least one audio transmitter comprising:

a first analog low pass filter receiving audio output from said at least one audio source;

a digital low pass filter;

an analog-to-digital converter (ADC) operatively coupled between said first analog and digital low pass filters;

a first encoder receiving output from said digital low pass filter and being configured to reduce intersymbol interference (ISI);

a second channel encoder operatively coupled to said first encoder and adapted to reduce transmission errors;

a digital modulator operatively coupled to said second channel encoder;

and

a differential phase shift key (DPSK) module receiving output from said digital modulator and being configured for direct sequence spread spectrum (DSSS) communication, said DPSK module transmitting a corresponding DSSS signal;

at least one audio receiver configured for digital wireless communication with said at least one audio transmitter, said at least one audio receiver comprising:

a band pass filter (BPF) configured to process said transmitted DSSS signal;

a direct conversion module receiving output from said BPF and being configured to capture the correct bit sequence embedded in said processed DSSS signal;

a digital demodulator adapted to process output from said direct conversion module;

a Viterbi decoder operatively coupled to said digital demodulator and generating a corresponding digital output;

a source decoder processing said digital output from said Viterbi decoder and being configured to decode the digital signal encoded by said first encoder;

a second analog low pass filter; and

a digital-to-analog converter (DAC) operatively coupled between said source decoder and said second analog low pass filter, said second analog low pass filter generating an audio output corresponding to the decoded and converted digital signal; and

at least one module adapted to reproduce said generated audio output, said audio output having been wirelessly transmitted from said at least one audio source to a user

without interference from other users or wireless devices.

Claim 44 (new). A wireless digital audio system, comprising:

at least one audio source;

at least one digital audio transmitter operatively coupled to said at least one audio source, said at least one audio transmitter comprising:

a first analog low pass filter receiving audio output from said at least one audio source;

a digital low pass filter;

an analog-to-digital converter (ADC) operatively coupled between said first analog and digital low pass filters;

a first encoder receiving output from said digital low pass filter and being configured to reduce intersymbol interference (ISI);

a second channel encoder operatively coupled to said first encoder and adapted to reduce transmission errors;

a digital modulator operatively coupled to said second channel encoder;  
and

a differential phase shift key (DPSK) module receiving output from said digital modulator and being configured for direct sequence spread spectrum (DSSS) communication, said DPSK module transmitting a corresponding DSSS signal;

at least one audio receiver configured for digital wireless communication with said at least one audio transmitter, said at least one audio receiver comprising:

a band pass filter (BPF) configured to process said transmitted DSSS

signal;

a direct conversion module receiving output from said BPF and being configured to capture the correct bit sequence embedded in said processed DSSS signal;

a digital demodulator adapted to process output from said direct conversion module;

a Viterbi decoder operatively coupled to said digital demodulator and generating a corresponding digital output;

a source decoder processing said digital output from said Viterbi decoder and being configured to decode the digital signal encoded by said first encoder;

a second analog low pass filter; and

a digital-to-analog converter (DAC) operatively coupled between said source decoder and said second analog low pass filter, said second analog low pass filter generating an audio output corresponding to the decoded and converted digital signal;

at least one module adapted to amplify said generated audio output; and

at least one module adapted to reproduce said amplified audio output, said audio output having been wirelessly transmitted from said at least one audio source to a user without interference from other users or wireless devices.

Claim 45 (new). The wireless digital audio system of Claim 43, wherein said at least one audio source provides analog output in the approximate range of 20 Hz to 20 kHz.



Claim 46 (new). The wireless digital audio system of Claim 44, wherein said at least one audio source provides analog output in the approximate range of 20 Hz to 20 kHz.

Claim 47 (new). The wireless digital audio system of Claim 43, wherein at least one of said digital audio transmitter and receiver is battery-powered.

Claim 48 (new). The wireless digital audio system of Claim 44, wherein at least one of said digital audio transmitter and receiver is battery-powered.

Claim 49 (new). The wireless digital audio system of Claim 43, wherein said at least one audio source is a portable music player.

Claim 50 (new). The wireless digital audio system of Claim 44, wherein said at least one audio source is a portable music player.

Claim 51 (new). A wireless digital audio transmitter, comprising:

a first analog low pass filter receiving audio output from at least one audio source;

a digital low pass filter;

an analog-to-digital converter (ADC) operatively coupled between said first analog and digital low pass filters;

a first encoder receiving output from said digital low pass filter and being

configured to reduce intersymbol interference (ISI);

a second channel encoder operatively coupled to said first encoder and adapted to reduce transmission errors;

a digital modulator operatively coupled to said second channel encoder;

and

a differential phase shift key (DPSK) module receiving output from said digital modulator and being configured for direct sequence spread spectrum (DSSS) communication, said DPSK module transmitting a corresponding DSSS signal.

Claim 52 (new). A wireless digital audio receiver, comprising:

a band pass filter (BPF) configured to process a transmitted DSSS signal;

a direct conversion module receiving output from said BPF and being configured to capture the correct bit sequence embedded in said processed DSSS signal;

a digital demodulator adapted to process output from said direct conversion module;

a Viterbi decoder operatively coupled to said digital demodulator and generating a corresponding digital output;

a source decoder receiving said digital output from said Viterbi decoder and being configured to decode the digital signal encoded therein;

a second analog low pass filter; and

a digital-to-analog converter (DAC) operatively coupled between said source decoder and said second analog low pass filter, said second analog low pass filter generating an audio output corresponding to the decoded and converted.

digital signal, said audio output having been wirelessly transmitted to a user without interference from other users or wireless devices.

Claim 53 (new). A wireless digital audio receiver utilizing embedded fuzzy logic to optimize digital signal processing, comprising:

a band pass filter (BPF) configured to process a transmitted DSSS signal;

a direct conversion module receiving output from said BPF and being configured to capture the correct bit sequence embedded in said processed DSSS signal;

a digital demodulator adapted to process output from said direct conversion module;

a Viterbi decoder operatively coupled to said digital demodulator and generating a corresponding digital output;

a source decoder receiving said digital output from said Viterbi decoder and being configured to decode the digital signal encoded therein;

a second analog low pass filter; and

a digital-to-analog converter (DAC) operatively coupled between said source decoder and said second analog low pass filter, said second analog low pass filter generating an audio output corresponding to the decoded and converted digital signal, said audio output having been wirelessly transmitted to a user without interference from other users or wireless devices.

**Amendments to the Drawings:**

Figs. 1 - 3 have been amended and are believed to be in compliance with 37 C.F.R. 1.152. Specifically, Fig. 1 has been amended to show embedded fuzzy logic detection sub-system 61 and to correct reference numeral 54 (headphone speakers) to 75. Reference numeral 54 corresponds to wideband bandpass filter (BPF) – see par. [0015] of parent patent application publication US 2003/0118196 A1. A replacement sheet containing amended Fig. 1 is submitted herewith as Exhibit 1 pursuant to MPEP 608.02(t). Figs. 2 – 3 have been amended to identify each component block, respectively, consistent with the specification. Reference numeral 54 designating the headphone speaker(s) has been corrected to 75. A replacement sheet containing amended Figs. 2 - 3 is submitted herewith as Exhibit 2 pursuant to MPEP 608.02(t).

Fig. 4 has been canceled. An annotated sheet containing markings to the effect that Fig. 4 has been canceled in its entirety is submitted herewith as Exhibit 3 pursuant to MPEP 608.02(t). A new sheet containing new Fig. 4 is submitted herewith as Exhibit 4 pursuant to 37. C.F.R. 1.121 (d). New Fig. 4 was originally submitted as Fig. 2 on filing of the instant continuation-in-part patent application. New Fig. 4 is believed to be in compliance with 37 C.F.R. 1.152.

### **REMARKS/ARGUMENTS**

Applicant has studied the Office Action of May 17, 2006 and made amendments to the specification, drawings and claims, as indicated hereinabove, to overcome the Examiner's objections and place the application in condition for allowance. No new matter has been added.

Claims 2 - 3, 5 and 8 - 9 have been cancelled without prejudice to filing future continuation application(s). Claims 1, 4, 6, 10 - 11 and 13 have been previously presented. Claim 12 has been amended, as indicated hereinabove. New claims 14 - 53 have been added. Therefore, claims 1, 4, 6 and 10 - 53, inclusive, are presently pending.

#### **Claim Rejections Under 35 U.S.C. §112**

Claims 1, 4, 6, 8 - 10 and 12 - 13 stand rejected under 35 U.S.C. §112, first paragraph, as failing to comply with the written description requirement. Claims 8 - 9 have been cancelled, as indicated hereinabove, rendering the Examiner's rejections thereto moot.

The rejections of Claims 1, 4, 6 and 10 under 35 U.S.C. §112, first paragraph, are respectfully traversed. Paragraphs [0014] and [0016] of the parent application disclose the features related to the generation of a unique codeword for an individual user. Pattern is defined as "an orderly sequence consisting of a number of repeated or complimentary elements . . . ." (New Lexicon Webster's Encyclopedic Dictionary of the English Language, Deluxe Edition 1991). The specification discloses how a unique codeword is generated that spreads the signal spectrum. Spreading or frequency hopping is used to

control the sequence (i.e. pattern) of carrier frequency. Based on the above, a person skilled in the art at the time the invention was made would clearly conclude that the generation of a unique codeword for each individual user is the same as generation of a unique hop pattern for each individual user when applying frequency hopping spread spectrum. For the reasons set forth above, applicant submits that claims 1, 4, 6 and 10 comply with the requirements set forth in 35 U.S.C. §112, first paragraph, and therefore, respectfully requests that the 35 U.S.C. §112 rejections in regard to these claims be withdrawn.

The rejections of claims 12 - 13 under 35 U.S.C. §112, first paragraph, are respectfully traversed. The Examiner alleges that the newly added limitation of "a 2.4 GHz direct conversion receiver that includes a spread spectrum communication demodulator and a receiver code generator" is not supported in the disclosure of neither the present application nor the parent application." Applicant respectfully submits that paragraph [0015], lines 5 - 7, parent application, states that, "The direct conversion receiver 56 may provide a method for down converting the received signal while utilizing timing and synchronization to capture the correct bit sequence embedded in the received spread spectrum signal." However, in the interest of moving forward, and without waiving any rights, Applicant has amended Claim 12, as indicated hereinabove. Claim 13 does not recite a 2.4 GHz direct conversion receiver that includes a spread spectrum communication demodulator and a receiver code generator. Therefore, Applicant respectfully submits that no amendment to Claim 13 is required to overcome the Examiner's rejection.

In view of the foregoing amendments and remarks, Applicant respectfully requests withdrawal of the §112 claim rejections.

**Claim Rejections Under 35 U.S.C. §103**

Claims 1, 4, 6 – 9 and 11 - 13 stand rejected under 35 U.S.C. §103(a) as being unpatentable over Alstatt (U.S. Patent 5,771,441) in view of Schotz et al (U.S. Patent 5,946,343) and in further view of Schotz (U.S. Patent 5,491,839), and in further view of Rozin (U.S. Patent 6,342,844). Claims 8 – 9 have been cancelled, as indicated hereinabove, rendering the Examiner's rejections thereto moot.

Claim 12 has been amended. The rejections of claims 1, 4, 6, 7, 11, 12 and 13 under 35 U.S.C. §103(a) are respectfully traversed. During the interview of June 13, 2006, the Examiners stated that if the evidence is correct, the combination [i.e. Alstatt in view of Schotz et al and in further view of Rozin], will no longer be applied in the rejection. Applicant submits herewith, as requested, an executed "Declaration of Applicant Under 35 USC Section 132" as Exhibit 5, and an executed "Declaration of Applicant Regarding Limited Battery Life Under 35 USC Section 132" as Exhibit 6 (collectively "Declarations"). Applicant respectfully submits that these Declarations under 35 U.S.C. §132 collectively address the Examiners' concerns relating to the obviousness rejections under 35 U.S.C. §103(a) as well some of the objections relating to new matter. Applicant further believes that the Amendment that was filed on March 14, 2006 also addresses some of the issues that are raised by the current Office action.

- Application Serial No. 10/648,012  
Response to Office Action of May 17, 2006  
Attorney Docket No. W003-4000

In view of the foregoing amendments and remarks, Applicant respectfully requests withdrawal of the §103(a) claim rejections in regard to claims 1, 4, 6, 7, 11, 12 and 13.

#### **New Matter Objections Regarding Specification**

Applicant has canceled recitation No. 1 on p. 5 of the instant Office Action rendering the Examiner's objections thereto moot. Applicant has retained recitations No. 2 - 3 on p. 5 - 6 of the instant Office Action and respectfully submits that the drawings and specification, as currently amended, provide adequate support for these recitations. Applicant has canceled recitation No. 4 on p. 6 of the instant Office Action rendering the Examiner's objections thereto moot.

#### **Interview Summary in Compliance with MPEP Section 713.04**

Applicant would like to thank Examiner Flanders and Supervisory Patent Examiner Sinh Tran (collectively "Examiners") for the courtesies extended during the Interview of June 13, 2006. Applicant is in receipt of the Interview Summary (Form PTOL-413) prepared by the Examiners dated June 23, 2006. Applicant has reviewed the Interview Summary and submits herewith, as requested, an executed "Declaration of Applicant Under 35 USC Section 132" as Exhibit 5, and an executed "Declaration of Applicant Regarding Limited Battery Life Under 35 USC Section 132" as Exhibit 6. Applicant further wishes to supplement the Interview Summary prepared by the Examiners, as follows. During the interview on June 13, 2006, among other things, Applicant also explained to the Examiners that unlike the Schotz's invention the Applicant's invention is designed to suppress self-interference (i.e., interference that



- Application Serial No. 10/648,012  
Response to Office Action of May 17, 2006  
Attorney Docket No. W003-4000

results from the use of multiple same devices operating simultaneously within the same space).

**Conclusion**

No amendment made was related to the statutory requirements of patentability unless expressly stated herein. Applicant has paid fees for additional claims through credit card based on the current fee schedule. However, if for some reason, any additional fees are due, Applicant respectfully requests the USPTO to contact the undersigned attorney. Applicant believes that the application, as presently amended, is in condition for allowance. If for any reason the Examiner finds the application other than in condition for allowance, the Examiner is respectfully requested to call the undersigned attorney at the telephone number listed herein below to discuss any steps necessary for placing the application in condition for allowance.

Respectfully submitted,  
THE PATEL LAW FIRM, P.C.



Natu J. Patel  
USPTO Reg. No. 39,559

Date: August 15<sup>th</sup>, 2006

NJP/ec  
Enclosure:

THE PATEL LAW FIRM, P.C.  
2532 Dupont Drive  
Irvine, California 92612-1524  
Business: (949) 955-1077  
Facsimile: (949) 955-1877

www.thepatellawfirm.com  
NPatel@thePatelLawFirm.com

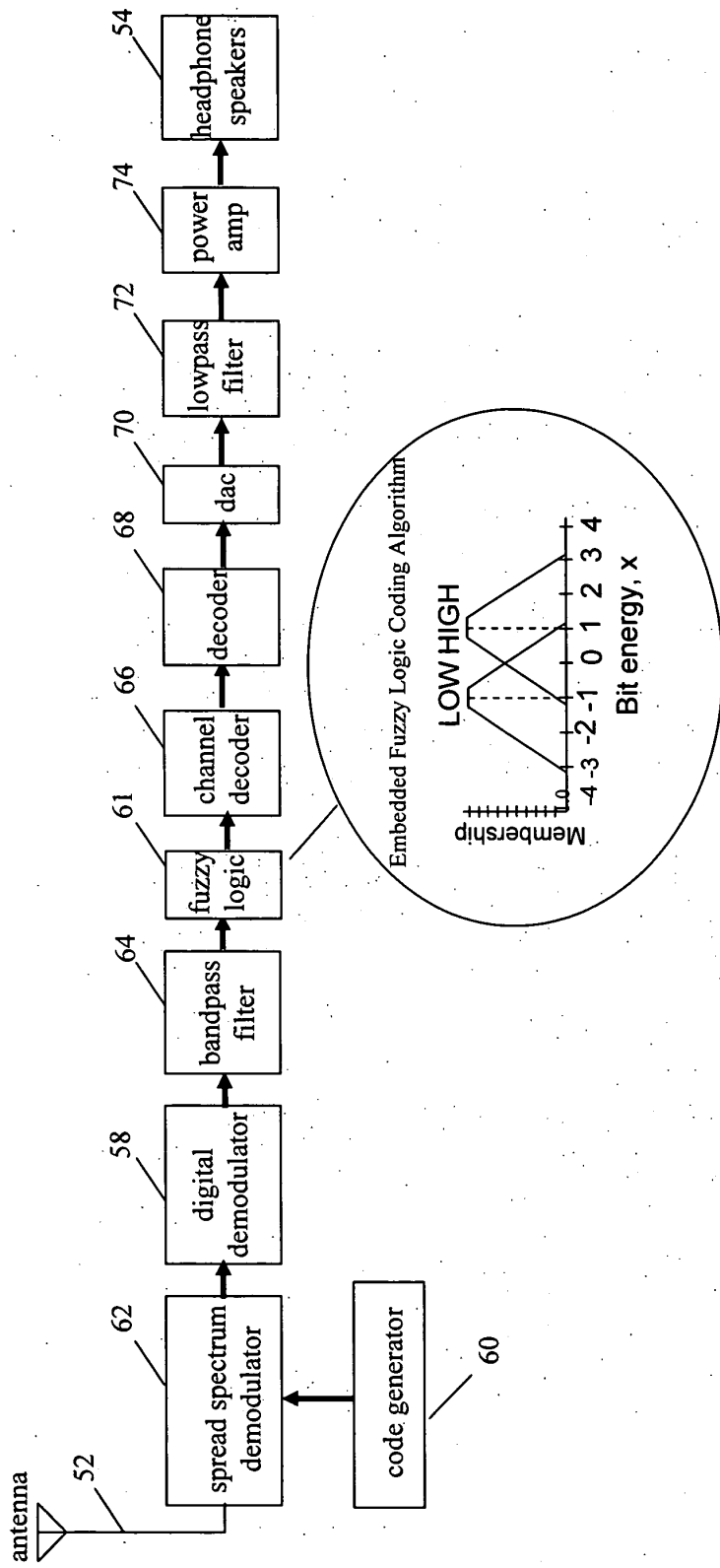

ANNOTATED SHEET

Figure 4  
(CANCELED)



REPLACEMENT SHEET

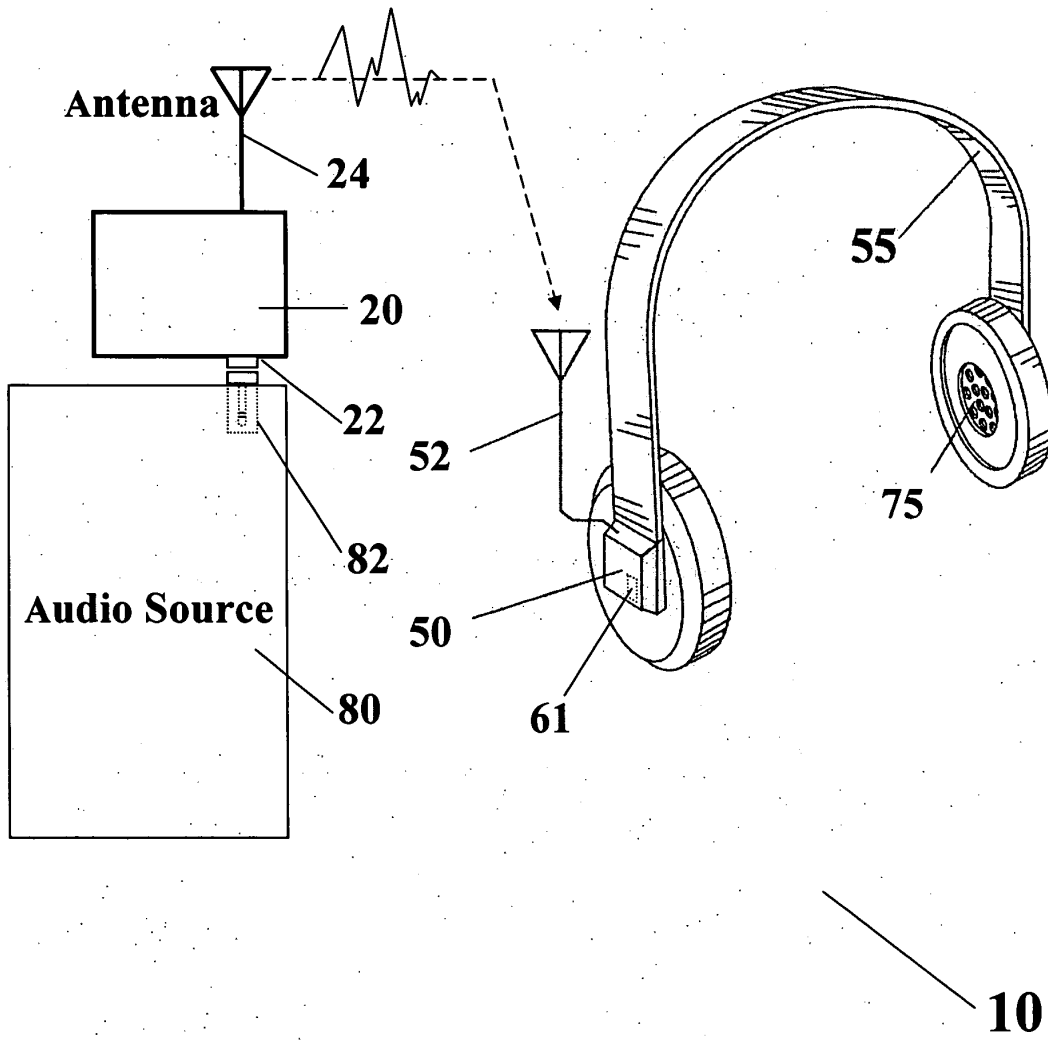

FIG.1

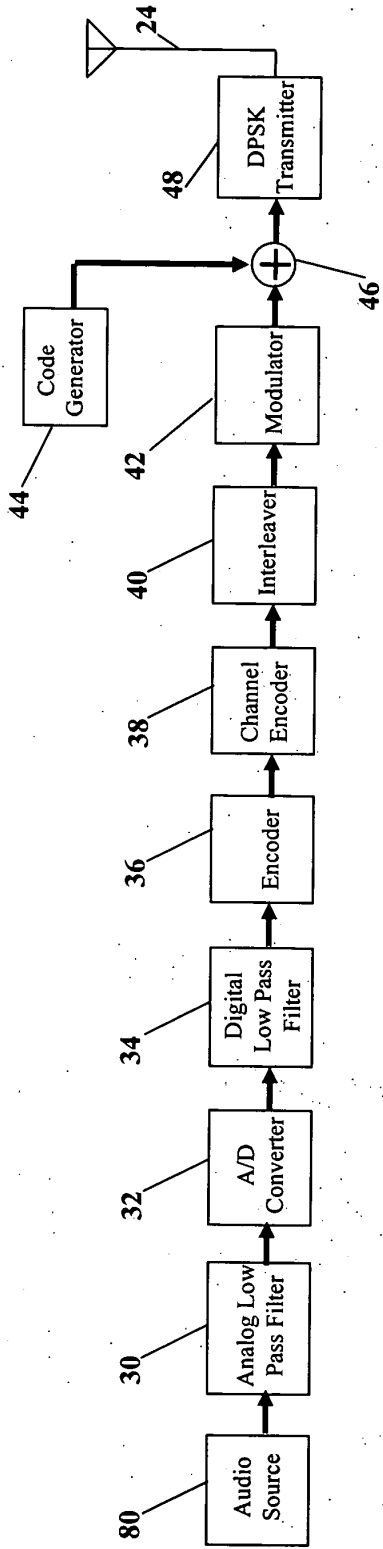

FIG. 2

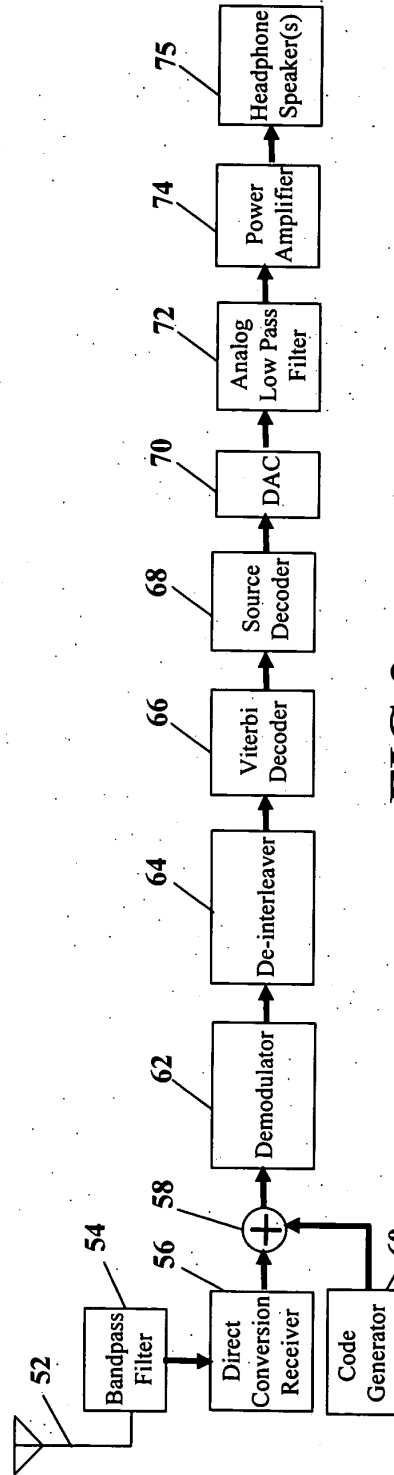

FIG. 3

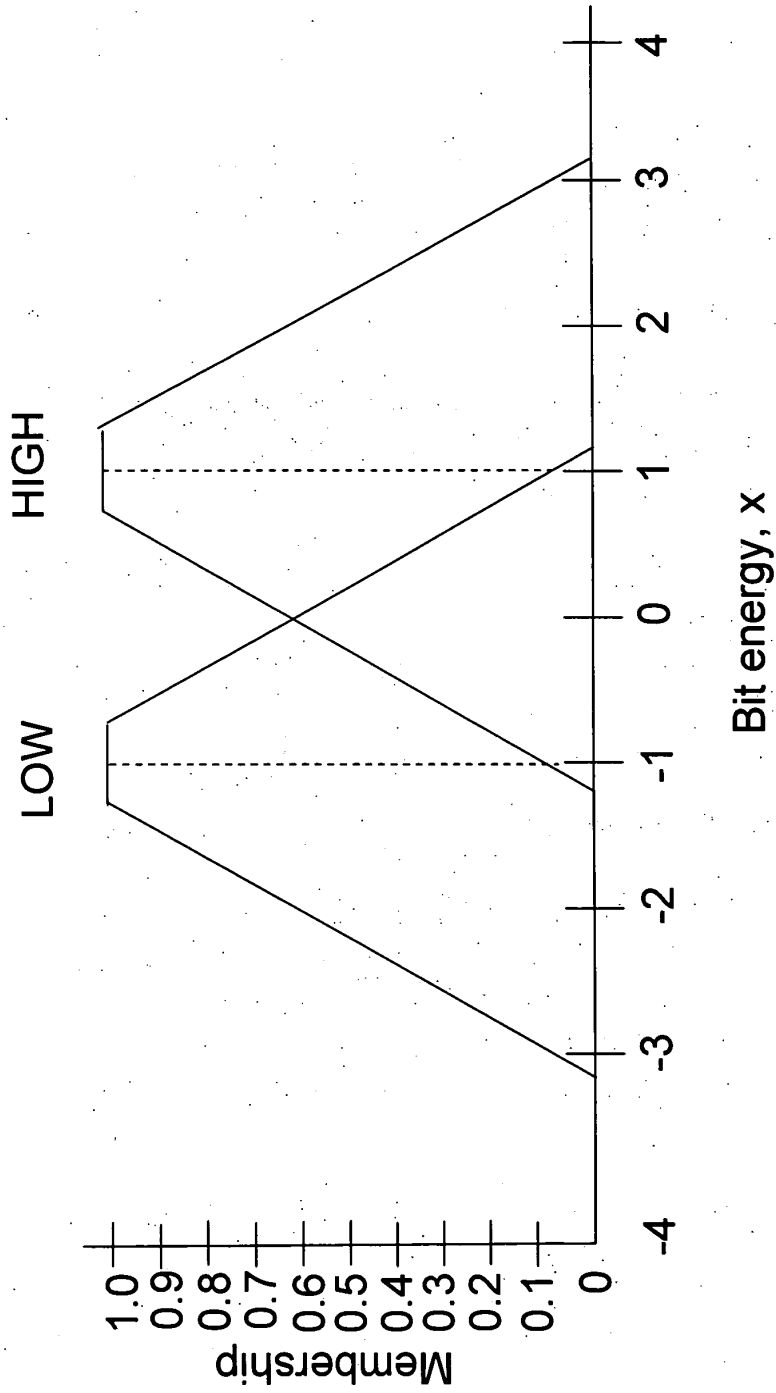
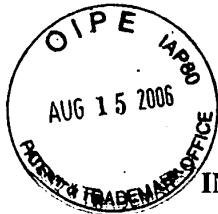
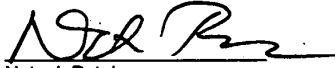

Fig. 4

NEW SHEET

I hereby certify that this correspondence (including Exhibits) is being deposited with the United States Postal Service via Express Mail in an envelope addressed to the Commissioner for Patents, P.O. Box 1450, Alexandria, VA 22313-1450, on August 15, 2006 (Express Mail Label No.: ET615079096US).



  
Natu J. Patel

**IN THE UNITED STATES PATENT AND TRADEMARK OFFICE**

In re Application of C. Earl Woolfork :  
Serial No. 10/648,012 : Group Art Unit: 2615  
Confirm. No.: 3337 : Examiner: Andrew C. Flanders  
Filed: August 26, 2003 :  
For: WIRELESS DIGITAL AUDIO MUSIC SYSTEM

**DECLARATION OF APPLICANT UNDER 35 USC Section 132**

I, C. Earl Woolfork, being duly sworn, depose and declare as follows:

1. I am the Inventor of the above referenced patent application ("Application"). I have personal knowledge of the following matter and if asked to testify, could and would testify competently, thereto.
2. Daphne Burton, my then attorney, conducted the interview with Examiner Flanders and Supervisory Patent Examiner Tran (collectively "Examiners") on June 13, 2006 regarding the pending office action dated May 17, 2006 ("Office Action"). I participated in that interview.
3. During the interview, among other things, page 6 of the Office Action was discussed, which states that, "A frequency shift keying (FSK) modulation/detection technique could be used given a frequency hopping spread spectrum (FHSS) system choice. The terms and techniques discussed in this sentence (FSK and FHSS) were not present in the parent disclosure nor in the current application's disclosure and thus are new matter."
4. During the interview, I explained to the Examiners that that FSK is an inherent feature of FHSS and that FHSS and direct sequence spread spectrum ("DSSS") are two inherent features of CDMA. In response to the discussion, Examiners requested that I submit evidence through an affidavit under 35 USC Section 132 providing substantiation.

5. I am hereby submitting this affidavit together with the supporting documentation for consideration and respectfully requesting that the new matter rejection relating to this particular issue be withdrawn.

6. Paragraph 0016, lines 14 – 16 of the Parent Application 10/027,391, recites in part that, "This code division multiple access technique (CDMA) may be used to provide each user independent operation."

7. Relevant pages from the well known text book entitled, "Spread Spectrum Systems with Commercial Applications," by Robert C. Dixon, Third Edition, are attached herewith as Exhibit A. Here are the relevant excerpts from Exhibit A:

a. "CDMA, or code-division multiple access systems, use codes to separate one signal from another . . . . Either direct sequence or frequency hopping systems can employ CDMA,..." (Refer to Page 2 of Exhibit A)

b. "For some reason which is not obvious, it is often assumed that CDMA and direct sequence methods are synonymous. Our discussion of CDMA in the previous section certainly applies to direct sequence (notice that the words "direct sequence" were never used) but also may be applied to frequency hopping." (Refer to Page 3 of Exhibit A)

c. "Frequency hopping modulation is more accurately termed multiple frequency, code selected, frequency shift keying. It is nothing more than FSK (frequency shift keying) except that the set of frequency choices is greatly expanded." (Refer to Page 4 of Exhibit A).

8. Based the above, it is apparent to one skilled in the art that FSK is an inherent feature of FHSS, and FHSS is one of the two inherent features of CDMA (the other inherent feature is DSSS).

Date: 8/14/00

Respectfully Submitted,

  
By: C. Earl Woolfork

EXHIBIT A

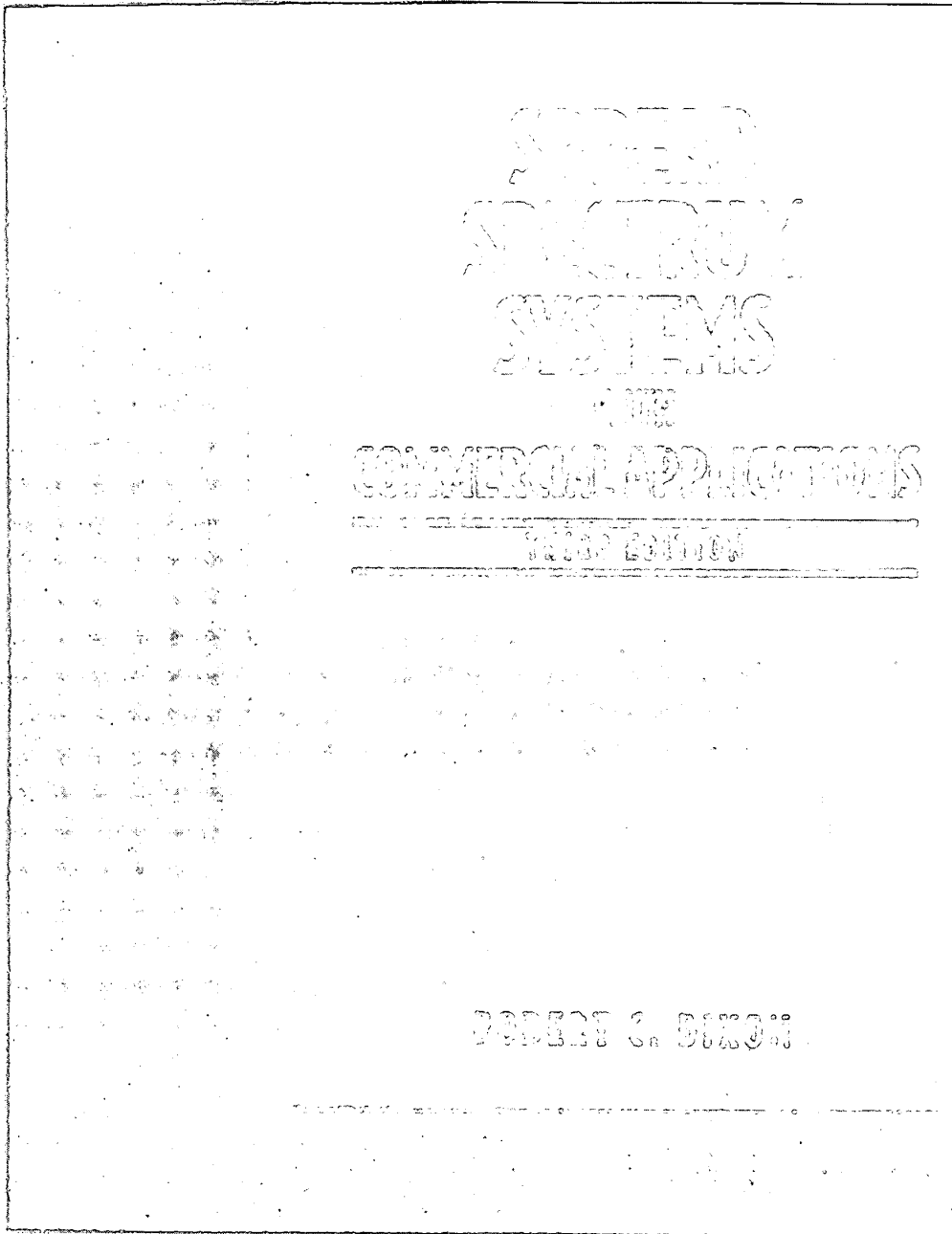

BEST AVAILABLE COPY 1



very significant property of TDMA is that users can operate together in a TDMA mode with no near-far problem at all.

Transmission of single-user-per-carrier TDMA is also a practical technique, and is the basis for "digital cellular" systems. In such systems, much of the overhead required is not taken up by actual transmission of data, however. Instead, to prevent signals that are transmitted by multiple users at varying distances from a receiver, from arriving at the same time, a guard space is added to each time slot.

In small cells, guard time may be insignificant, but in large cells, guard time may actually take up more time than is allowed for data transmission. Since radio signals repropagate at approximately six microseconds per mile, any distance uncertainty in the position of a transmitter with respect to a receiver must appear in the guard time allowance in every time slot. Time slot size and guard time are both very important, at larger time slots mean fewer guard times, but processing delay may be longer.

With the 197.9 users we previously postulated, let us consider an example:

- Suppose each 8-Kbps user has 100 time slots per second. He must transmit his data in 30-bit increments, with eight bits of overhead.
- There are 19,790 time slots per second available, each with period 50.5805 microseconds.
- Data is transmitted in 38-bit chunks, at a rate of 1.71820 megabits per second. Thus 4.6 microseconds per time slot is left for guard time, and this in turn allows approximately a 0.75-mile range uncertainty.
- If longer time slots are used, with fewer per user, longer guard time and therefore larger cells could be accommodated.

This example is intended merely to show the relationships involved in TDMA systems (single user per carrier).

**Code-Division Multiple Access**



CDMA, or code-division multiple access systems, use codes to separate one signal from another (as we have previously discussed in Chapter 1). Either direct sequence or frequency hopping systems can employ CDMA, so we will compare both methods to FDMA and TDMA approaches.

CDMA systems are dependent on the design of codes that are "orthogonal" to one another, at least within the set of codes employed in a network. Orthogonality in this context means simply that all of the codes used must have low enough mutual cross-correlation that they do not significantly interfere with one another over the dynamic range of the signals presented to any receiver in a CDMA network. This is the purpose of the Gold codes, Kasami codes, and Bent codes discussed in Chapter 3. Unfortunately, there is no known set of codes that is completely orthogonal when used in the

conditions\*. Our ability to access system with a large n under these conditions is due, in part, to the fact that we can add as many more interference power levels if the codes use same time, then the total power because a receiver will work signals does not exceed the jamming margin. Therefore, if all users' signals are equal, jamming margin is a-dime

RF band  
data:

In a 1-MHz bandwidth, will naturally

$$\frac{1 \times 10^6 \text{ Hz}}{8 \text{ Kbps}}$$

and the maximum number users, each of which needs 126.

Improvements might be processing gain reducing to 1000.

In frequency hopping, the receiver's jamming margin, frequencies interfered with.

In the ISM bands, at 1000-MHz band, and 75 frequencies 20% of these frequencies number of users possible we

$$50/3 = 1$$

\*Note that 197.9 users are not orthogonal, but they are nearly orthogonal in other directions, and this is why in 1.72 per 1.82 Mbps with the same 10 TDMA users would be an 19.79 users. CDMA would be a bit better, but not by a large margin of users.

If we compare time division CDMA to power-control CDMA, in multiuser networks (for example, a network with a single base station and many randomly distributed users scattered around it), it is easy to see that:

- The time division base station requires only one transmitter and one receiver to service all its associated users. (This includes any signal processing that is to be done.) The power-control base station, on the other hand, requires a separate transmit channel\* and a separate receive channel for every user. This means that a power-control system with 32 users would require 32 transmit channels and 32 receive channels, while the time division system requires only one.

If more users are accommodated, by either reducing data rates, or by expanding a base station's coverage, then the number of transmitters and receivers simply goes up by the same amount as the increase in users. Increasing processing gain, and thereby increasing margin/number of users, by reducing data rate would allow

Data Rate	Linking Margin	Number of Users
8 Kbps	15.9 dB	39.25
4 Kbps	18.9 dB	98.5
2 Kbps	21.9 dB	157

From this we see the value of reducing the data rate in a spread spectrum system. We note, however, that reducing the data rate in non-spread-spectrum systems can produce similar results. (We will see an example of this in the succeeding pages.)

**Important Note:**

It is of no use whatsoever to consider the number of users possible in a spread spectrum system to be 30, 100, or any other number unless the codes employed (remember that we are discussing code division multiple access) are capable of providing sufficiently low cross-correlation between every user and every other user.

**Frequency Hopping and CDMA**

\*For some reason which is not obvious, it is often assumed that CDMA and direct sequence methods are synonymous. Our discussion of CDMA in the previous section certainly applies to direct sequence (though that the words "direct sequence" were never used) but also may be applied to frequency hopping.

\*A single power amplifier and a single receiver circuit (even power can be fed, but separate processing, modulation and demodulation is still needed for every user because each user's separate code is different from every other user's).

If one has any or more bandwidth, but using direct called code division multiple no matter that some mistake only direct sequence with etc. How many users are practical users is a function of the rate that we have a 1.25-MHz RF rate 1/2 ending 19.2-K or correctable. We will also use 1/2. CDMA is MSK modulation.

Bandwidth per channel  
 Number of channels available  
 Linking MARGIN (dB)

Linking Margin (other w)

(This assumes five channels of jammed channel produces a In military systems, it is respect to every other user, many channels available using each user with respect sequentially uses the same randomly interfere with one support up to 832 users to Commercial users are a hopped channels or to enable that efficiency of code sequence to every channel in the band approach is effectively the in channel being used, interference greatly increased.

32 SPREAD SPECTRUM TECHNIQUES

some advantages. (2) Other forms of direct sequence modulation cannot match. We hasten to state that there are many forms of MSK modulation, each with different spectrum and characteristics. Offset QPSK is, in fact, one form of MSK modulation. We will further discuss these forms and compare their characteristics in detail in Chapter 4.

2.2 FREQUENCY HOPPING\*

\* "Frequency hopping" modulation is more accurately termed "multiple-frequency, uncoordinated, frequency shift keying." It is nothing more than FSK (frequency shift keying) except that the set of frequency choices is greatly expanded. Simple FSK most often uses only two frequencies, for example  $f_1$  to signify a "mark,"  $f_2$  to signify a "space." Frequency hoppers, on the other hand, often have thousands of frequencies available. One real system<sup>(1)</sup> has  $2^{20}$  discrete frequency choices, randomly chosen, each selected on the basis of a code in combination with the information transmitted. The number of frequency choices and the rate of hopping from frequency to frequency in any frequency hopper is governed by the requirements placed on it for a particular use.

Characteristics of Frequency Hopping Signals

A frequency hopping system or "frequency hopper" consists basically of a code generator and a frequency synthesizer capable of responding to the coded output from the code generator. A great deal of effort has been expended in developing rapid-response frequency synthesizers for spread spectrum systems.

Ideally, the instantaneous frequency hopper output is a single frequency. Practically, however, the system user must be satisfied with an output spectrum which is a composite of the desired frequencies, sidebands generated by hopping, and spurious frequencies generated as by products.

Figure 2.12 is a simplified block diagram of a frequency hopping transmission system. The frequency spectrum of this frequency hopper is shown in Figure 2.13.

Over a period of time, the ideal frequency hopping spectrum would be perfectly rectangular, with transmissions distributed evenly in every available frequency channel. The transmitter should also be designed to transmit to a degree as close as practical, the same amount of power in every channel.

The received frequency hopping signal is mixed with a locally generated replica, which is offset a fixed amount such that  $(f_1, f_2, \dots, f_n) \times (f_1 + f_m, f_2 + f_m, \dots, f_n + f_m)$  produces a constant difference frequency  $f_m$  when transmitter and receiver code sequences are in synchronism.

\* See the Bibliography Section, p. 7, in 2.3.





I hereby certify that this correspondence (including Exhibits) is being deposited with the United States Postal Service via Express Mail in an envelope addressed to the Commissioner for Patents, P.O. Box 1450, Alexandria, VA 22313-1450, on August 15, 2006 (Express Mail Label No.: ET615079096US).

*Natu J. Patel*  
Natu J. Patel

**IN THE UNITED STATES PATENT AND TRADEMARK OFFICE**

In re Application of C. Earl Woolfork :  
Serial No. 10/648,012 : Group Art Unit: 2615  
Confirm. No.: 3337 : Examiner: Andrew C. Flanders  
Filed: August 26, 2003 :  
For: WIRELESS DIGITAL AUDIO MUSIC SYSTEM

**DECLARATION OF APPLICANT REGARDING LIMITED BATTERY LIFE**  
**UNDER 35 USC Section 132**

I, C. Earl Woolfork, being duly sworn, depose and declare as follows:

1. I am the Inventor of the above referenced patent application ("Application"). I have personal knowledge of the following matter and if asked to testify, could and would testify competently, thereto.
2. Daphne Burton, my then attorney, conducted the interview with Examiner Flanders and Supervisory Patent Examiner Tran (collectively "Examiners") on June 13, 2006 regarding the pending office action dated May 17, 2006. I participated in that interview.
3. During the interview, among other things, we discussed U.S. Patent No. 5,771,441 issued to Altstatt ("Alstatt" or "the 441 Patent") and U.S. Patent No. 5,946,343 issued to Schotz ("Schotz" or "the 343 Patent").
4. Examiners requested that I submit evidence in an affidavit under 35 USC Section 132 explaining as to why the combination of Altstatt in view of Schotz is non-operative due to limited battery life.
5. I am hereby submitting this affidavit and all the supporting documentation to the Examiners for their consideration.

**BEST AVAILABLE COPY**

6. Altstatt's invention is based on an analog technology and is operated by a battery. Altstatt recites that the maximum value of V is fixed by the battery voltage of 1.5 or possibly 3 volts (Column 8, lines 22-24).

7. Schotz' invention is based on digital technology. Schotz's digital wireless speaker system requires 120VAC at 60Hz. Schotz further states that "[b]oth the transmitter 22 and the receiver 24 have respective power circuits (not shown) that convert input power (e.g., 120VAC at 60 Hz) into proper voltage levels for appropriate transmitter and receiver operation." Please refer to Column 14, lines 1-4.

8. Exhibit A, attached hereto, lists the commercially available Integrated Chip components ("IC Components") that both Altstatt and Schotz identify in their respective designs. Datasheets identifying electrical current requirements to operate the IC Components are included in Exhibit B.

9. Altstatt cannot be combined with Schotz. However, even assuming such a combination is possible, the Altstatt's battery powered analog headphone system will suffer from a significantly reduced playtime due to the power consumption of Schotz's numerous integrated circuit components, as articulated in the calculation spreadsheet attached hereto as Exhibit C.

10. The "playtime" is defined as the time the invention can be operated continuously before the battery must be changed or recharged. The playtime calculation consists of simple unit conversions as defined in chapter one, problem 1.5 and solution set of well known Theodore S. Rappaport's Wireless Communications Principles & Practice textbook. The relevant pages from the textbook are attached herewith as Exhibit D.

According to Exhibit D, the formula for the playtime calculation is:

$$\frac{((60\text{minutes}/1\text{hour}) \times B\text{mA-h})}{((60\text{ minutes}/\text{hour} \times 24\text{ hour}/\text{day})(\text{sum of IC currents in mA}))} \times (24\text{hour}/\text{day})$$

where B is the battery current capacity.

11. As shown in Exhibit C, Altstatt's portable invention will yield a playtime greater than 10 hours when operated with a small battery having a current capacity of 50mA-h (50 milliamp-hours).

12. If we were to hypothetically apply the same 50mA-h battery capacity to operate Schotz's invention, Exhibit C further shows that the frequency hopping spread spectrum ("FHSS") system will operate for approximately six minutes, and the direct sequence spread spectrum ("DSSS") system will operate for approximately eleven

Docket No.: W003-4000

PATENT

minutes before requiring a new battery or a recharged battery. Please note that the FHSS and DSSS system operations are constrained to the lowest device (transmitter or receiver) operation time.

Date:

4/14/06

Respectfully Submitted,

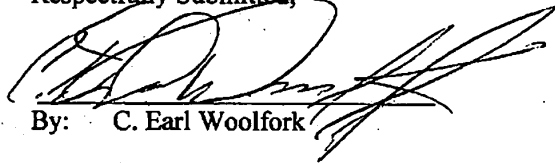

By: C. Earl Woolfork

## EXHIBIT A

### US Patent Number: 5,771,441 Issued to Altstatt

Number	Component Description	Reference
1	Transmitter, BA1404	column 5, lines 34-37
2	Receiver, TA7766AF	column 8, lines 54-58
3	Receiver, TA7792F	column 8, lines 54-58

### US Patent Number: 5,946,343 Issued to Schotz

1	Digital Signal Processor, DSP56002	column 14, lines 49-50
2	A/D converter, SAA7360	column 7, lines 11-12
3	Stereo Filter MPEG, SAA2520	column 14, lines 47-48
4	MPEG, SAA2521	column 14, lines 47-48
5	Modulator, RF2422	column 10, lines 17-18
6	Power Amplifier, TQ9132	column 10, lines 31-32
7	Phase Locked Loop, MC12210	column 10, lines 49-50
8	Voltage Controlled Oscillator, SMV2500	column 14, lines 51-53
9	Low Noise Amplifier, MGA86576	column 11, lines 16-18
10	Digital Interface Transmitter, CS8402	column 11, lines 31-33
11	Digital to Analog Converter, TDA1305T	column 13, lines 57-59
12	Clock Recovery & Timing, TRU-050	column 12, lines 28-29
13	Demodulator, RF2703	column 12, lines 13-15
14	Microprocessor, PIC16C55	column 6, lines 63-66
15	DSSS Transmitter, CYLINK SSTX	column 16, lines 62-64
16	DSSS Receiver, CYLINK Part#SPECTRE	column 18, lines 4-5
17	Mixer, IAM81008	column 11, lines 16-18
18	Channel Encoder/Decoder, SRT241203	column 9, lines 25-26
19	Interleaver/De-interleaver, SRT-24INT	column 9, lines 50-52
20	Optical Digital Receiver, HK-3131-01	column 7, lines 40-43
21	Optical Digital Transmitter, HK-3131-03	column 13, lines 15-17
22	Voltage Controlled Oscillator, M2 D300	column 8, lines 49-50

# EXHIBIT B

## US Patent Number: 5,771,441 Issued to Altstatt

Item Number 1: Transmitter, BA1404

ROHM CO LTD 40E D ■ 7828999 0004568 6 ■ RHM  
オーディオ用 IC/ICs for Audio Applications BA1404/BA1404F

● ブロックダイアグラム/Block Diagram

T-77-05-05

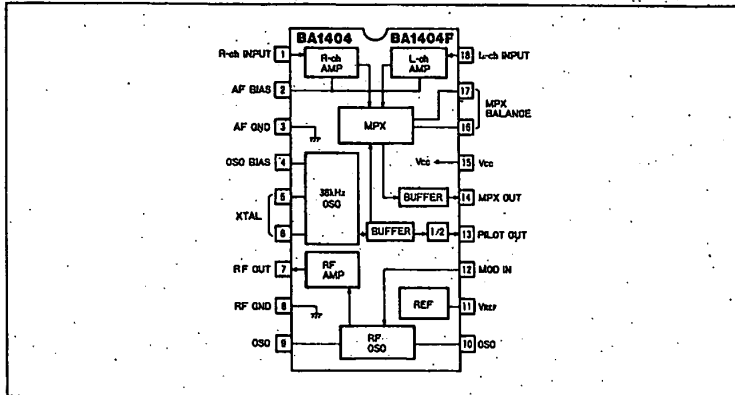

● 絶対最大定格/Absolute Maximum Ratings (Ta=25°C)

Parameter	Symbol	Limits	Unit
電源電圧	V <sub>CC</sub>	2.6	V
許容損失	P <sub>d</sub>	500*	mW
動作温度範囲	T <sub>opr</sub>	-25~76	°C
保存温度範囲	T <sub>stg</sub>	-50~125	°C

\* Ta=25°C以上で使用する場合は、1°Cにつき85mWを減じる

● 推奨動作条件/Recommended Operating Conditions (Ta=25°C)

Parameter	Symbol	Min.	Typ.	Max.	Unit
電源電圧	V <sub>CC</sub>	1	1.25	2	V

● 電気的特性/Electrical Characteristics (Ta=25°C, V<sub>CC</sub>=1.25V)

Parameter	Symbol	Min.	Typ.	Max.	Unit	Conditions
無信号時電流	I <sub>Q</sub>	0.5	3	5	mA	—
入力インピーダンス	Z <sub>IN</sub>	380	640	720	Ω	f <sub>IN</sub> =1kHz
入力利得	G <sub>V</sub>	30	37	—	dB	V <sub>IN</sub> =0.5mV
チャンネルバランス	CB	—	—	2	dB	V <sub>IN</sub> =0.5mV
MPX最大出力電圧	V <sub>OM</sub>	200	—	—	mV <sub>p-p</sub>	THD≤3%
MPX 38kHzもれ	V <sub>OO</sub>	—	1	—	mV	無信号時
パイロット出力電圧	V <sub>OP</sub>	460	580	—	mV <sub>p-p</sub>	無負荷時
チャンネルセパレーション	Sep	25	45	—	dB	基準復調器にて
入力換算雑音電圧	V <sub>NIN</sub>	—	1	—	μV <sub>rms</sub>	38kHz停止時 IHF-A
RF部最大出力電圧	V <sub>OSO</sub>	350	600	—	mV <sub>rms</sub>	—

ROHM

1149

オーディオ用 IC/ICs for Audio Applications



# US Patent Number: 5,771,441 Issued to Altstatt

Item Number 2: Receiver, TA 7766AF

TOSHIBA

TA7766AF

ELECTRICAL CHARACTERISTICS (Unless otherwise specified,  $T_0 = 25^\circ\text{C}$ ,  $V_{CC} = 1.5\text{V}$ ,  $f_m = 1\text{kHz}$ )

CHARACTERISTIC		SYMBOL	TEST CIRCUIT	TEST CONDITION	MIN.	TYP.	MAX.	UNIT
Supply Current		$I_{CC}$	—	All lamp off	—	0.8	1.6	mA
Input Resistance		$R_{IN}$	—		—	36	—	k $\Omega$
Output Resistance		$R_{OUT}$	—		—	15	—	k $\Omega$
Max. Composite Signal Input Voltage		$V_{in(MAX)}$ (STEREO)	—	L + R = 90% P = 10% THD = 5% SW1 → R <sub>L</sub> ED = 50k $\Omega$ SW2 → LPF ON	—	250	—	mV <sub>rms</sub>
Separation		Sep	—	L + R = 10mV <sub>rms</sub> P = 10mV <sub>rms</sub> SW1 → R <sub>L</sub> ED = 50k $\Omega$ SW2 → LPF ON	$f_m = 100\text{Hz}$	—	30	—
					$f_m = 1\text{kHz}$	22	35	—
Total Harmonic Distortion		Monaural (MONAURAL)	—	$V_{in} = 100\text{mV}_{rms}$ SW1 → R <sub>L</sub> ED = 500 $\Omega$	—	0.2	1.3	%
				STEREO	L + R = 90mV <sub>rms</sub> P = 10mV <sub>rms</sub> SW1 → R <sub>L</sub> ED = 50k $\Omega$ SW2 → LPF ON	—	0.4	
Voltage Gain		$G_V$	—	$V_{in} = 100\text{mV}_{rms}$ SW1 → R <sub>L</sub> ED = 500 $\Omega$	-4	-2	1	dB
Channel Balance		CB	—	$V_{in} = 100\text{mV}_{rms}$ SW1 → R <sub>L</sub> ED = 500 $\Omega$	—	0	2.0	dB
Lamp ON Sensitivity		$V_L$ (ON)	—	Pot SW1 → R <sub>L</sub> ED = 50k $\Omega$	—	—	5	mV <sub>rms</sub>
Lamp OFF Sensitivity		$V_L$ (OFF)	—	Input SW1 → R <sub>L</sub> ED = 500 $\Omega$	—	7	—	mV <sub>rms</sub>
Stereo Lamp Hysteresis		$V_H$	—	In turn-off from turn-on	—	3	—	mV <sub>rms</sub>
Capture Range		CR	—	P = 10mV <sub>rms</sub>	—	±3	—	Hz
Carrier Leak (Noise)		19kHz	—	L + R = 90mV <sub>rms</sub> P = 10mV <sub>rms</sub> SW1 → R <sub>L</sub> ED = 50k $\Omega$	—	30	—	dB
		30kHz		—	50	—		
SCA Rejection Ratio		SCA Rej	—	P = 10mV <sub>rms</sub> , L + R = 90mV <sub>rms</sub> SCA = 10mV <sub>rms</sub> , $f_{SCA} = 67\text{kHz}$ SW1 → R <sub>L</sub> ED = 50k $\Omega$	—	70	—	dB
Signal to Noise Ratio		S/N	—	$V_{in} = 100\text{mV}_{rms}$ , $R_p = 620\Omega$ SW1 → R <sub>L</sub> ED = 500 $\Omega$	—	65	—	dB

(Note) Carrier leak of 30kHz is only carrier.

# US Patent Number: 5,771,441 Issued to Altstatt

Item Number 3: Receiver, TA 7792F

**TOSHIBA**

**TA7792P/F**

**MAXIMUM RATINGS (Ta = 25°C)**

CHARACTERISTIC	SYMBOL	RATING	UNIT
Supply Voltage	V <sub>CC</sub>	5	V
Power Dissipation	TA7792P	750	mW
	TA7792F	350	mW
Operating Temperature	T <sub>OP</sub>	-25~75	°C
Storage Temperature	T <sub>STG</sub>	-55~150	°C

(Note) Denoted above Ta = 25°C in the proportion of 6mW/°C for TA7792P, and of 2.8mW/°C for TA7792F.

**ELECTRICAL CHARACTERISTICS**

Unless otherwise specified, Ta = 25°C, V<sub>CC</sub> = 1.5V

FM : V<sub>in</sub> = 600μV EMF, f = 833kHz, f<sub>m</sub> = 1kHz, df = ±22.5kHz  
 AM : V<sub>in</sub> = 600μV EMF, f = 1kHz, f<sub>m</sub> = 1kHz, MOD = 30%

CHARACTERISTIC	SYMBOL	TEST CIRCUIT	TEST CONDITION	MIN.	TYP.	MAX.	UNIT
Supply Current	I <sub>CC</sub> (FM)	1	V <sub>in</sub> = 0	—	4.0	5.2	mA
	I <sub>CC</sub> (AM)	1	V <sub>in</sub> = 0	—	1.2	1.8	mA
Input Limiting Voltage	V <sub>in</sub> (lim)	1	-3dB limiting	—	10	15	dBμV EMF
Total Harmonic Distortion	THD(FM)	1		—	0.29	—	%
Signal to Noise Ratio	SIN(FM)	1		—	62	—	dB
Quietest Sensitivity	Q <sub>s</sub>	1	S/N = 30dB	—	12	—	dBμV EMF
AM Rejection Ratio	AMR	1	MOD = 30%	—	30	—	dB
Oscillator Voltage	V <sub>osc</sub>	2	f = 833kHz	5.1	9.0	13.5	mV <sub>rms</sub>
Oscillator Stop Supply Voltage	V <sub>osc</sub> (UM)	1	V <sub>in</sub> < -20dBμV EMF	—	0.85	0.95	V
Recovered Output Voltage	V <sub>OD</sub> (FM)	1		28	45	60	mV <sub>rms</sub>
Voltage Gain	G <sub>v</sub>	1	V <sub>in</sub> = 30dBμV EMF	14	25	52	mV <sub>rms</sub>
Recovered Output Voltage	V <sub>OD</sub> (AM)	1		25	40	60	mV <sub>rms</sub>
Total Harmonic Distortion	THD(AM)	1		—	1.5	—	%
Signal to Noise Ratio	SIN(AM)	1		—	40	—	dB
Oscillator Stop Supply Voltage	V <sub>osc</sub> (AM)	1	V <sub>in</sub> < -20dBμV EMF	—	0.85	0.95	V
Output Resistance R <sub>in</sub> B	FM	R <sub>0</sub> (FM)	f = 1kHz	—	1.4	—	Ω
	AM	R <sub>0</sub> (AM)	f = 1kHz	—	8	—	Ω

③ V<sub>in</sub> : Open Display

# US Patent Number: 5,946,343 Issued to Schotz

Item Number 1: Digital Signal Processor, DSP56002

Specifications

DC Electrical Characteristics

## DC ELECTRICAL CHARACTERISTICS

Table 2-3 DC Electrical Characteristics

Characteristic	Symbol	Min	Typ	Max	Units
Supply Voltage	V <sub>CC</sub>	4.5	5.0	5.5	V
Input High Voltage					
• EXTAL	V <sub>IHC</sub>	4.0	—	V <sub>CC</sub>	V
• RESET	V <sub>IHR</sub>	2.5	—	V <sub>CC</sub>	V
• MODA, MODB, MODC	V <sub>IHM</sub>	2.5	—	V <sub>CC</sub>	V
• All other inputs	V <sub>IH</sub>	2.0	—	V <sub>CC</sub>	V
Input Low Voltage					
• EXTAL	V <sub>ILC</sub>	-0.5	—	0.6	V
• MODA, MODB, MODC	V <sub>ILM</sub>	-0.5	—	2.0	V
• All other inputs	V <sub>IL</sub>	-0.5	—	0.8	V
Input Leakage Current	I <sub>IN</sub>	-1	—	1	µA
EXTAL, RESET, MODA/IKQA, MODB/IKQB, MODC/NSM, TR, BR, WT, CKP, PINT, NCEC, MICCLK, MCCLK, D2M					
Tri-state (Off-state) Input Current (@ 2.4V/0.4V)	I <sub>TI</sub>	-10	—	10	µA
Output High Voltage (I <sub>OH</sub> = -0.1 mA)	V <sub>OH</sub>	2.1	—	—	V
Output Low Voltage (I <sub>OL</sub> = 3.0 mA) FREQ I <sub>OL</sub> = 0.7 mA, TXD I <sub>OL</sub> = 0.7 mA	V <sub>OL</sub>	—	—	0.4	V
Internal Supply Current at 40 MHz <sup>1</sup>	I <sub>CC1</sub>	—	80	105	mA
• In Wait mode <sup>2</sup>	I <sub>CCW</sub>	—	12	29	mA
• In Stop mode <sup>2</sup>	I <sub>CCS</sub>	—	2	95	µA
Internal Supply Current at 66 MHz <sup>1</sup>	I <sub>CC1</sub>	—	95	130	mA
• In Wait mode <sup>2</sup>	I <sub>CCW</sub>	—	15	25	mA
• In Stop mode <sup>2</sup>	I <sub>CCS</sub>	—	2	95	µA
Internal Supply Current at 80 MHz <sup>1</sup>	I <sub>CC1</sub>	—	115	160	mA
• In Wait mode <sup>2</sup>	I <sub>CCW</sub>	—	18	30	mA
• In Stop mode <sup>2</sup>	I <sub>CCS</sub>	—	2	95	µA
PLL Supply Current <sup>3</sup>					
• 40 MHz		—	1.0	1.5	mA
• 66 MHz		—	1.1	1.5	mA
• 80 MHz		—	1.2	1.8	mA
CRCOUT Supply Current <sup>4</sup>					
• 40 MHz		—	14	20	mA
• 66 MHz		—	28	35	mA
• 80 MHz		—	34	42	mA
Input Capacitance <sup>5</sup>	C <sub>IN</sub>	—	10	—	pF

Notes: 1. Section 4 Design Considerations describes how to minimize the external supply current.  
 2. In order to obtain these results all inputs must be terminated (i.e., not allowed to float).  
 3. Values are given for PLL enabled.  
 4. Values are given for CRCOUT enabled.  
 5. Periodically sampled and not averaged.

MOTOROLA

DSP56002/D, Rev. 3

2-3

# US Patent Number: 5,946,343 Issued to Schotz

## Item Number 2: A/D Converter, SAA7360

Philips Semiconductors	Product specification
Bitstream conversion ADC for digital audio systems	SAA7360

Table 1. Output data format

ODF2	ODF1	MODE
0	0	12bit
0	1	format 1
1	0	format 2
1	1	1AS

**Reset:**

When the RESET pin is held LOW the data outputs are set to zero. The RESET pin operates as a Schmitt trigger, enabling a power-on reset function by using an external RC circuit.

**LIMITING VALUES**

In accordance with the Absolute Maximum Rating System (IEC 134).

SYMBOL	PARAMETER	CONDITIONS	MIN.	MAX.	UNIT
V <sub>DDA</sub>	analog supply voltage	note 1	-0.5	+5.5	V
V <sub>D</sub>	DC input voltage		-0.5	+5.5	V
I <sub>IC</sub>	DC input-side current		-	±20	mA
V <sub>DO</sub>	DC output voltage		-0.5	V <sub>DD</sub> + 0.5	V
I <sub>IO</sub>	DC output source or sink current		-	±20	mA
I <sub>DD(TOT)</sub>	total DC I <sub>DD</sub> or V <sub>DD</sub> current		-	±0.6	A
T <sub>amb</sub>	operating ambient temperature		-40	+85	°C
T <sub>stg</sub>	storage temperature		-55	+150	°C
V <sub>ESD</sub>	electrostatic handling	note 2	-2000	+2000	V
		note 3	-200	+200	V

**Notes**

1. All V<sub>DD</sub> and V<sub>DO</sub> pins must be externally connected to the same power supply.
2. Equivalent to discharging a 100 pF capacitor via a 1.5 kΩ series resistor with a rise time of 65 ns.
3. Equivalent to discharging a 100 pF capacitor via a 1.5 pF series inductor.

**CHARACTERISTICS**

V<sub>DD</sub> = 5 V; T<sub>amb</sub> = 25 °C; V<sub>IN</sub> = 256/16 = 16.0 kHz; unless otherwise specified.

SYMBOL	PARAMETER	CONDITIONS	MIN.	TYP.	MAX.	UNIT
<b>Supplies</b>						
V <sub>DDA</sub>	analog supply voltage		4.5	5.0	5.5	V
I <sub>DDA</sub>	analog supply current		-	45	-	mA
V <sub>DDD</sub>	digital supply voltage		4.5	5.0	5.5	V
I <sub>DDD</sub>	digital supply current		-	30	-	mA
P <sub>DD</sub>	total power consumption		-	485	-	mW

# US Patent Number: 5,946,343 Issued to Schotz

Item Number 3: Stereo Filter MPEG, SAA2520

Philips Semiconductor Preliminary specification

Stereo filter and codec for MPEG layer 1 audio applications SAA2520

### LIMITING VALUES

In accordance with the Absolute Maximum System (IEC 134).

SYMBOL	PARAMETER	CONDITIONS	MIN.	MAX.	UNIT
$V_{DD}$	supply voltage		-0.5	5.5	V
$V_I$	input voltage	note 1	-0.5	$V_{DD} + 0.5$	V
$I_{DD}$	supply current from $V_{DD}$		-	180	mA
$I_{CC}$	supply current to $V_{DD}$		-	180	mA
$I_I$	input current		-10	10	mA
$I_O$	output current		-20	20	mA
$P_{tot}$	total power dissipation		-	350	mW
$T_{stg}$	storage temperature range		-65	150	°C
$T_{opr}$	operating temperature range		-40	85	°C
$V_{ESD}$	electrostatic discharging	note 2	-1500	1500	V
$V_{ESD}$	electrostatic handling	note 3	-75	75	V

### Notes

1. Input voltage should not exceed 5.5 V unless otherwise specified.
2. Equivalent to discharging a 100 pF capacitor through a 1.5 kΩ series resistor.
3. Equivalent to discharging a 100 pF capacitor through a 50 Ω series resistor.

### DC CHARACTERISTICS

$T_{amb} = -40$  to  $85$  °C;  $V_{DD} = 2.8$  to  $5.5$  V unless otherwise specified.

SYMBOL	PARAMETER	CONDITIONS	MIN.	TYP.	MAX.	UNIT
<b>Supply</b>						
$V_{DD}$	supply voltage range		2.8	5.0	5.5	V
$I_{DD}$	operating current	$V_{DD} = 5$ V (note 1)	-	82	110	mA
$I_{CC}$	operating current	$V_{DD} = 3.5$ V (note 1)	-	88	80	mA
<b>Inputs URCA, SBDIR, SBER, LTCLK, LTCHTO, LTNCTN, X22IN, X24IN</b>						
$V_{IH}$	HIGH level input voltage	$C.P.V_{DD}$	-	-	-	V
$V_{IL}$	LOW level input voltage		-	-	$C.P.V_{DD}$	V
$I_I$	input current	$V_I = 0$ V; $T_{amb} = 25$ °C	-	-	10	mA
$I_I$	input current	$V_I = 5.5$ V; $T_{amb} = 25$ °C	-	-	10	mA
<b>Inputs PWRDWN, LTENA</b>						
$V_{IH}$	HIGH level input voltage	$C.P.V_{DD}$	-	-	-	V
$V_{IL}$	LOW level input voltage		-	-	$C.P.V_{DD}$	V
$I_I$	input current	$V_I = V_{DD}$ ; $T_{amb} = 25$ °C	40	-	150	mA

AN10011553

29

# US Patent Number: 5,946,343 Issued to Schotz

Item Number 4: MPEG, SAA2521

Philips Semiconductors Primary specification

Masking threshold processor for MPEG  
layer 3 audio compression applications

SAA2521

### DC CHARACTERISTICS

$V_{DD} = 2.5$  to  $5.5$  V;  $T_{AMB} = -40$  to  $85$  °C; unless otherwise specified.

SYMBOL	PARAMETER	CONDITIONS	MIN.	TYP.	MAX.	UNIT
<b>Supply</b>						
$V_{DD}$	supply voltage range		2.5	3	5.5	V
$I_{CR}$	operating current	$V_{DD} = 3.3$ V	-	18	20	mA
$I_{CR}$	operating current	$V_{DD} = 5$ V	-	25	30	mA
$I_{WDDW}$	stand-by current	in power-down mode	-	100	-	µA
<b>Inputs</b>						
$V_{IL}$	LOW level input voltage		0	-	$0.2 V_{DD}$	V
$V_{IH}$	HIGH level input voltage		$0.7 V_{DD}$	-	$V_{DD}$	V
$I_{I}$	input current		-	-	10	µA
<b>Outputs</b>						
$V_{OL}$	LOW level output voltage	note 1	-	-	0.4	V
$V_{OH}$	HIGH level output voltage	note 1	$V_{DD} - 0.5$	-	-	V
<b>3-state outputs</b>						
$I_{OZ}$	OFF state current	$V_I = 0$ to $5.5$ V	-	-	10	µA

### Note

1. Maximum load current for LTC101A, LTC101C, LTC101D, LTC101E, LTC101K, TEST1, TEST2, FDAC, FCAF = 2 mA; for LTC101G = 3 mA.

AN10511E53

24

# US Patent Number: 5,946,343 Issued to Schotz

Item Number 5: Modulator, RF2422

## RF2422

### Absolute Maximum Ratings

Parameter	Rating	Unit
Supply Voltage	-0.5 to +7.5	V <sub>CC</sub>
Input LO and RF Levels	+10	dBm
Operating Ambient Temperature	-40 to +85	°C
Storage Temperature	-43 to +125	°C

 Caution: ESD sensitive device

© 2001 Sony Electronics Inc. All rights reserved. This document is the property of Sony Electronics Inc. and is intended for use only in connection with the products described herein. No part of this document may be reproduced without the prior written permission of Sony Electronics Inc.

5  
MODULATORS AND CONVERTERS

Parameter	Specification			Unit	Condition
	Min.	Typ.	Max.		
<b>Carrier Input</b>					T=25°C, V <sub>CC</sub> =5V
Frequency Range	800		2500	MHz	
Power Level	-8		+0	dBm	
Input VSWR		5:1			At 900MHz
		1.8:1			At 1500MHz
		1.2:1			At 2500MHz
<b>Modulation Input</b>					
Frequency Range	DC		250	MHz	
Reference Voltage (V <sub>REF</sub> )	2.0	3.0		V	
Maximum Modulation (ISM)			V <sub>REF</sub> +1.0	V	
Carrier Amplitude		0.2		dB	
Quadrature Phase Error		3		°	
Input Resistance		50		Ω	
Input Bias Current			40	μA	
<b>RF Output</b>					LO=700MHz and 900MHz, ISQ=2.0Vpp, ISB
Output Power	-3		+3	dBm	
Output Impedance		50		Ω	
Output VSWR		3.5:1			At 900MHz
		1.5:1			At 2000MHz
		1.15:1			At 2500MHz
Return Loss	-20	-20		dB	
Sideband Suppression	25	35		dB	
Carrier Distortion	20	35		dB	
1dB Suppression	20	35		dB	Information of the carrier and the carrier RF signal
Spurious Emission	25	30		dB	Information of baseband signals
Spurious Emission				dBm/Hz	At 50MHz offset, V <sub>CC</sub> =5V
				dBm/Hz	Tied to V <sub>REF</sub> (E10, G10, I10E1 and G10E1)
				dBm/Hz	At 250MHz
				dBm/Hz	At 1500MHz
<b>Power Down</b>					
Turn On/Off Time			100	ns	
PD Input Resistance	50			Ω	
Power On/Off V <sub>CC</sub>			0.5	V	Threshold voltage
Power On/Off V <sub>REF</sub>	1.0	1.2		V	Threshold voltage
<b>Power Supply</b>					
Voltage	4.5	5	6.0	V	See features
Current		45	50	mA	Operating Mode
			25	μA	Power Down

# US Patent Number: 5,946,343 Issued to Schotz

Item Number 6: Power Amplifier, TQ9132

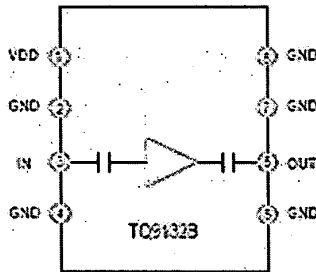

### Product Description

The TQ9132B amplifier is an ESD-2500 MHz amplifier capable of providing moderate output power (50 mW) for a wide variety of transmit and receive applications. The amplifier's input and output are matched to 50 Ω with internal circuitry, simplifying interfaces to 50 Ω systems. In addition, DC blocking capacitors are included on chip, permitting direct connections to the input and output. Its 8-pin surface mount package and low cost are well suited to many wireless communications applications.

### Electrical Specifications<sup>1</sup>

Parameter	Min	Typ	Max	Units
Gain	13.5	15		dB
Output 65 dB Gain Compression	15.5	17		dBm
Input Return Loss		12		dB
Output Return Loss		12		dB
DC Supply Current		18	100	mA

Note 1: Test conditions:  $V_{DD} = 3.0\text{ V}$ ,  $f_{sig} = 1500\text{ MHz}$ ,  $Z_0 = 50\ \Omega$ .  
 (Min, Typ, Max values shown in parentheses)

## TQ9132B

### DATA SHEET

### 3V Cellular TDMA/AMPS Power Amplifier IC

#### Features

- Single 3V-3V supply
- Wide frequency range
- +17 dBm output power
- Input and output matched to 50 Ω
- SO-8 surface mount plastic package

#### Applications

- Power Amplifier drivers
- PCN Modem-power amplifiers
- Medium-power MLAs
- GPRS Modems
- Base Station receivers

For more detailed information and latest specifications, see our website: [www.triquint.com](http://www.triquint.com)



# US Patent Number: 5,946,343 Issued to Schotz

## Item Number 7: Phase Locked Loop, MC12210

### MC12210

ELECTRICAL CHARACTERISTICS (V<sub>DD</sub> = 0.7 to 6.5 V; I<sub>A</sub> = -40 to +35°C unless otherwise noted)

Parameter	Symbol	Min	F <sub>TD</sub>	Max	Unit	Conditions
Supply Current for V <sub>DD</sub>	I <sub>DD</sub>	-	2.5	13.0	mA	Note 1
		-	10.2	19.0		Note 2
Supply Current for I <sub>P</sub>	I <sub>P</sub>	-	0.7	1.1	mA	Note 3
		-	0.5	1.3		Note 4
Operating Frequency	f <sub>OSC</sub> <sup>1</sup>	2500	-	-	MHz	Note 5
		-	-	500		
Operating Frequency (CECn)	F <sub>CECn</sub>	-	12	30	MHz	Crystal Mode
		-	-	40	MHz	External Reference Mode
Input Sensitivity	I <sub>N</sub>	200	-	1000	eV/Hz	
	C <sub>CECn</sub>	WOSC	EW	-	eV/Hz	
Input HIGH Voltage (CLR, DATA, LE, FC)	V <sub>IH</sub>	0.7 V <sub>DD</sub>	-	-	V	
Input LOW Voltage (CLR, DATA, LE, FC)	V <sub>IL</sub>	-	-	0.3 V <sub>DD</sub>	V	V <sub>DD</sub> = 5.5 V
Input HIGH Current (DATA and C <sub>CECn</sub> )	I <sub>IH</sub>	-	1.0	2.0	μA	V <sub>DD</sub> = 5.5 V
Input LOW Current (DATA and C <sub>CECn</sub> )	I <sub>IL</sub>	-10	-3.0	-	μA	V <sub>DD</sub> = 5.5 V
Input Current (C <sub>CECn</sub> )	I <sub>CCECn</sub>	-	100	-	μA	C <sub>CECn</sub> = V <sub>DD</sub> C <sub>CECn</sub> = V <sub>DD</sub> - 2.0 V
Input HIGH Current (LE and FC)	I <sub>IH</sub>	-	1.0	2.0	μA	
Input LOW Current (LE and FC)	I <sub>IL</sub>	-75	-6.0	-	μA	
Charge Pump Output Current	I <sub>CHARGE</sub> <sup>2</sup>	-2.8	-2.0	-1.4	mA	V <sub>DD</sub> = V <sub>CP2</sub> = V <sub>CP</sub> = 2.7 V
	I <sub>CH1</sub> <sup>3</sup>	+1.4	+2.0	+2.8	mA	V <sub>DD</sub> = V <sub>CP2</sub> = V <sub>CP</sub> = 2.7 V
	I <sub>CH2</sub> <sup>3</sup>	+1.5	-	+1.5	mA	0.5 × V <sub>DD</sub> + V <sub>P</sub> = 0.5 0.5 × V <sub>DD</sub> + V <sub>P</sub> = 0.5
Output HIGH Voltage (Q <sub>1</sub> , Q <sub>R</sub> , Q <sub>P</sub> , I <sub>OUT1</sub> )	V <sub>OH</sub>	4.4	-	-	V	V <sub>DD</sub> = 5.0 V
		2.4	-	-	V	V <sub>DD</sub> = 5.5 V
Output LOW Voltage (Q <sub>1</sub> , Q <sub>R</sub> , Q <sub>P</sub> , I <sub>OUT1</sub> )	V <sub>OL</sub>	-	-	0.4	V	V <sub>DD</sub> = 5.0 V
		-	-	0.4	V	V <sub>DD</sub> = 5.5 V
Output HIGH Current (Q <sub>1</sub> , Q <sub>R</sub> , Q <sub>P</sub> , I <sub>OUT1</sub> )	I <sub>OH</sub>	-1.0	-	-	mA	
Output LOW Current (Q <sub>1</sub> , Q <sub>R</sub> , Q <sub>P</sub> , I <sub>OUT1</sub> )	I <sub>OL</sub>	1.0	-	-	mA	

1. V<sub>DD</sub> = 3.3 V, all outputs open.  
2. V<sub>DD</sub> = 5.5 V, all outputs open.  
3. V<sub>P</sub> = 3.5 V, all outputs open.

4. V<sub>P</sub> = 0.0 V, all outputs open.  
5. AD casing; f<sub>OSC</sub> measured with a 100 pF capacitor.  
6. Current limit flows out of the pin and sink current flows into the pin.

Figure 8. Typical External Charge Pump Circuit

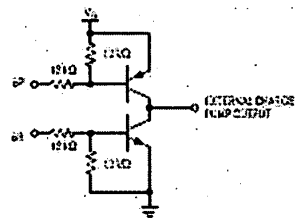
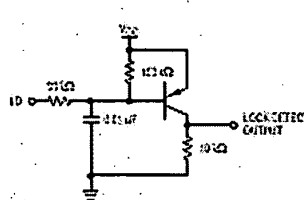

Figure 9. Typical Lock Detect Circuit



# US Patent Number: 5,946,343 Issued to Schotz

Item Number 8: Voltage Controlled Oscillator, SMV2500



**SMV2500L**  
VOLTAGE CONTROLLED OSCILLATOR



PHASE NOISE (1 Hz BW, typical)

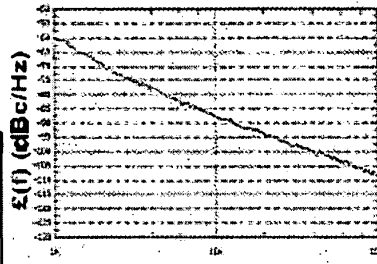

FEATURES	
• Frequency Range:	2400 - 2484 MHz
• Tuning Voltage:	0-3 Vcc
• SMD - 5 Pin Package	
APPLICATIONS	
• Personal Communications Systems	
• WLAN	
• Portable Radios	

PERFORMANCE SPECIFICATIONS	VALUE	UNITS
Oscillation Frequency Range	2400 - 2484	MHz
Phase Noise @ 10 kHz Offset (1 Hz BW, typ.)	-37	dBc/Hz
Harmonic Suppression (Std. typ.)	-20	dB
Tuning Voltage	0-3	Vcc
Tuning Sensitivity (avg.)	100	MHz/V
Power Output	9.25±2.75	dBm
Load Impedance	50	$\Omega$
Input Capacitance (max.)	50	pF
Pushing	+30	MHz/V
Pulling (14 dB Return Loss, Any Phase)	+25	MHz
Operating Temperature Range	-40 to 85	$^{\circ}$ C
Package Style	SMD	
POWER SUPPLY REQUIREMENTS		
Supply Voltage (Nom. min.)	3	Vcc
Supply Current (Icc, typ.)	19	$\mu$ A

\*1 Specifications are typical values of the device and are subject to change without notice.

APPLICATION NOTES	
• AN-1001: Mounting and Grounding of VCOs	
• AN-1002: Proper Output Loading of VCOs	
• AN-1007: How to Solder Z-COMM VCOs	

NOTES:

# US Patent Number: 5,946,343 Issued to Schotz

Item Number 9: Low Noise Amplifier, MBA86576

## Absolute Maximum Ratings

Symbol	Parameter	Units	Absolute Maximum <sup>1,2</sup>
$V_{ds}$	Device Voltage, RF output to ground	V	9
$V_{gs}$	Device Voltage, RF input to ground	V	-0.5 -1.0
$P_{in}$	CW RF Input Power	dBm	+3
$T_{ca}$	Channel Temperature	$^{\circ}$ C	150
$T_{stg}$	Storage Temperature	$^{\circ}$ C	-65 to 150

The term Resistance<sup>1,2</sup>:  
 $\theta_{JA} = 110^{\circ}$ C/W

Notes:  
1. Operation of this device above any one of these limits may cause permanent damage.  
2.  $T_c = 150^{\circ}$ C ( $T_c$  is defined to be the temperature at the package pins where contact is made to the circuit board).

## MGA-S6576 Electrical Specifications, $T_c = 25^{\circ}$ C, $Z_0 = 50\ \Omega$ , $V_{gs} = 5V$

Symbol	Parameters and Test Conditions	Units	Min.	Typ.	Max.
$G_p$	Power Gain ( $ S_{21} ^2$ ) $f = 1.5\text{ GHz}$ $f = 2.5\text{ GHz}$ $f = 4.0\text{ GHz}$ $f = 6.0\text{ GHz}$ $f = 8.0\text{ GHz}$	dB	20	21.2 21.7 23.1 19.8 15.1	
$NF_{50}$	50 $\Omega$ Noise Figure $f = 1.5\text{ GHz}$ $f = 2.5\text{ GHz}$ $f = 4.0\text{ GHz}$ $f = 6.0\text{ GHz}$ $f = 8.0\text{ GHz}$	dB		2.2 1.5 2.0 2.3 2.5	2.9
$NF_0$	Optimum Noise Figure (input tuned for lowest noise figure) $f = 1.5\text{ GHz}$ $f = 2.5\text{ GHz}$ $f = 4.0\text{ GHz}$ $f = 6.0\text{ GHz}$ $f = 8.0\text{ GHz}$	dB		1.6 1.5 1.6 1.9 2.1	
$P_{1dB}$	Output Power at 1 dB Gain Compression $f = 1.5\text{ GHz}$ $f = 2.5\text{ GHz}$ $f = 4.0\text{ GHz}$ $f = 6.0\text{ GHz}$ $f = 8.0\text{ GHz}$	dBm		14 7.0 6.3 4.3 3.3	
$IP_3$	Third Order Intercept Point $f = 4.0\text{ GHz}$	dBm		16.0	
VSWR	Input VSWR $f = 1.5\text{ GHz}$ $f = 2.5\text{ GHz}$ $f = 4.0\text{ GHz}$ $f = 6.0\text{ GHz}$ $f = 8.0\text{ GHz}$			2.2:1 2.2:1 2.2:1 1.8:1 1.2:1	3.6:1
	Output VSWR $f = 1.5\text{ GHz}$ $f = 2.5\text{ GHz}$ $f = 4.0\text{ GHz}$ $f = 6.0\text{ GHz}$ $f = 8.0\text{ GHz}$			2.2:1 2.1:1 1.5:1 1.8:1 1.8:1	
$I_{ds}$	Device Current	mA	9	10	22

S-229

# US Patent Number: 5,946,343 Issued to Schotz

Item Number 10: Digital Interface Transmitter, CS8402



CS8401A CS8402A

## ABSOLUTE MAXIMUM RATINGS (GND = 0V, all voltages with respect to ground.)

Parameter	Symbol	Min	Max	Units
DC Power Supply	V <sub>DD</sub>		5.0	V
Input Current: Any Pin Except Supply	I <sub>I</sub>		±10	mA
Digital Input Voltage	V <sub>IHI</sub>	-0.3	V <sub>DD</sub>	V
Ambient Operating Temperature (power applied)	T <sub>A</sub>	-55	125	°C
Storage Temperature	T <sub>STG</sub>	-55	150	°C

Notes: 1. Transient currents of up to 100 mA will not cause SCR latchup.

WARNING: Operation at or beyond these limits may result in permanent damage to the device. Normal operation is not guaranteed at these extremes.

## RECOMMENDED OPERATING CONDITIONS

(GND = 0V, all voltages with respect to ground.)

Parameter	Symbol	Min	Typ	Max	Units
DC Voltage	V <sub>DD</sub>	4.5	5.0	5.5	V
Supply Current	I <sub>CC</sub>		1.5	3	mA
Ambient Operating Temperature: CS8401(A)/OP or -CS	T <sub>A</sub>	0	25	70	°C
CS8401(A)/P or -CS		-40		85	°C
Power Consumption	P <sub>D</sub>		7.5	25	mW

Notes: 2. Drivers open (unloaded). The majority of power is used by the load connected to the drivers.  
3. The "OP" and "CS" parts are specified to operate over 0 to 70 °C but are tested at 25 °C only. The "P" and "IS" parts are tested over the full -40 to 85 °C temperature range.

## DIGITAL CHARACTERISTICS

(T<sub>A</sub> = 25 °C for all "OP" & "CS", T<sub>A</sub> = -40 to 85 °C for "P" & "IS", V<sub>DD</sub> = 5V ± 10%)

Parameter	Symbol	Min	Typ	Max	Units
High-Level Input Voltage	V <sub>IH</sub>	2.0		V <sub>DD</sub> -0.3	V
Low-Level Input Voltage	V <sub>IL</sub>	-0.3		-0.8	V
High-Level Output Voltage (I <sub>O</sub> = 200mA)	V <sub>OHI</sub>	V <sub>DD</sub> -0.3			V
Low-Level Output Voltage (I <sub>O</sub> = 3.2mA)	V <sub>OL</sub>			0.4	V
Input Leakage Current	I <sub>I</sub>		1.0	10	µA
Master Clock Frequency:	MCK			22	MHz
CS8401A	Note 4			7.5	MHz
CS8402A	Note 4				
Master Clock Duty Cycle		40		60	%

Notes: 4. MCK for the CS8401 must be 125, 192, 258, or 324; the input word rate based on M0 and M3 in control register 2. MCK for the CS8402A must be 128x the input word rate, except in Transparent Mode where MCK is 256x the input word rate.

Operating conditions are subject to change without notice.

# US Patent Number: 5,946,343 Issued to Schotz

## Item Number 11: Digital to Analog Converter, TDA1305T

Philips Semiconductors	Preliminary specification
Stereo 1fs data input up-sampling filter with bitstream continuous dual DAC (SCC-DAC2)	TDA1305T

### CLICK REFERENCE DATA

SYMBOL	PARAMETER	CONDITIONS	MIN.	TYP.	MAX.	UNIT
$V_{DD0}$	digital supply voltage	note 1	3.4	5.0	5.5	V
$V_{DDA}$	analog supply voltage	note 1	3.4	5.0	5.5	V
$V_{DD1}$	operational amplifier supply voltage	note 1	3.4	5.0	5.5	V
$I_{DD0}$	digital supply current	$V_{DD0} = 5\text{ V};$ at $f_{CLK} = 300000\text{ Hz}$	-	30	-	mA
$I_{DDA}$	analog supply current	$V_{DDA} = 5\text{ V};$ at $f_{CLK} = 300000\text{ Hz}$	-	5.5	9	mA
$I_{DD1}$	operating amplifier supply current	$V_{DD1} = 5\text{ V};$ at $f_{CLK} = 300000\text{ Hz}$	-	6.5	9	mA
$V_{OH(1)}$	full-scale output voltage (RMS value)	$V_{DD0} = V_{DDA} = V_{DD1} = 5\text{ V}$	1.423	1.5	1.573	V
$(THD + N)_{FS}$	total harmonic distortion, plus noise-to-signal ratio	at 0 dB signal level	-	-90	-31	dB
		at -60 dB signal level	-	-100	-20	dB
		at -60 dB signal level; A-weighted	-	-43	-	dB
		at $f_{CLK} = 300000\text{ Hz}$	-	0.5	-	dB
SNR	signal-to-noise ratio at full-scale	A-weighted; at $f_{CLK} = 300000\text{ Hz}$	100	103	-	dB
$BR_{FS}$	input bit rate at data input	$f_s = 48\text{ kHz}$ ; normal speed	-	-	3.072	Mbit/s
$BR_{DS}$	input bit rate at data input	$f_s = 48\text{ kHz}$ ; double speed	-	-	6.144	Mbit/s
$f_{CLK}$	system clock frequency		6.4	-	18.432	MHz
$TCR_{FS}$	full-scale temperature coefficient at analog outputs (VOL and VOR)		-	$\pm 100 \times 10^{-6}$	-	
$T_{amb}$	operating ambient temperature		-30	-	+85	°C

#### Note

1. All  $V_{DD0}$  and  $V_{DD1}$  pins must be connected to the same supply.

1995 Cec 03

3

# US Patent Number: 5,946,343 Issued to Schotz

## Item Number 12: Clock Recovery & Timing, TRU-050

7. For each of the above-referenced test and test recovery applications, the input clock rate shall be 100 MHz and the output clock rate shall be 100 MHz. The input clock rate shall be 100 MHz and the output clock rate shall be 100 MHz. The input clock rate shall be 100 MHz and the output clock rate shall be 100 MHz.
8. The input clock rate shall be 100 MHz and the output clock rate shall be 100 MHz.
9. The input clock rate shall be 100 MHz and the output clock rate shall be 100 MHz.
10. The input clock rate shall be 100 MHz and the output clock rate shall be 100 MHz.
11. The input clock rate shall be 100 MHz and the output clock rate shall be 100 MHz.
12. The input clock rate shall be 100 MHz and the output clock rate shall be 100 MHz.

Parameter	Symbol	Min	Max	Unit
Input Clock Rate	$f_{clk}$	0.999	1.001	MHz
Output Clock Rate	$f_{out}$	0.999	1.001	MHz
Input Clock Frequency				
Class 1	$f_{clk1}$	120	65.530	MHz
Class 2	$f_{clk2}$	2.05	22.328	MHz
Supply Voltage	$V_{cc}$	2.5	5.5	V
Supply Current ( $V_{cc} = 3.3V$ )	$I_{cc}$	25	43	mA
Output Voltage Level ( $V_{out} = 0.5V$ )				
Class 1	$V_{out1}$	2.5	-	V
Class 2	$V_{out2}$	-	0.5	V
Output Level				
Class 1	$V_{out1}$	0.5	5	mV
Class 2	$V_{out2}$	5	5	mV
Output Delay				
Class 1	$t_{d1}$	45	60	ps
Class 2	$t_{d2}$	45	55	ps
Output Delay	$t_{d}$	45	60	ps
Input Delay	$t_{in}$	20	-	ps
Input Delay	$t_{in}$	-	50	ps
Output Delay (Class 1) ( $V_{out} = 2.5V$ )	$t_{d1}$	50	-	ps
Output Delay (Class 2) ( $V_{out} = 0.5V$ )	$t_{d2}$	-	50	ps
Output Delay ( $V_{out} = 0.5V$ )	$t_{d}$	50	50	ps
Input Delay	$t_{in}$	2.5	-	ps
Output Delay	$t_{out}$	0.5	-	ps
Output Delay (Class 1) (in terms of $f_{clk}$ )				
Class 1	$t_{d1}$	0.5 ps	75 ps	periods to 1
Class 2	$t_{d2}$	0.5 ps	75 ps	periods to 2
Output Delay (Class 1)	$t_{d1}$	0.5	0.5	ps

Table 1.

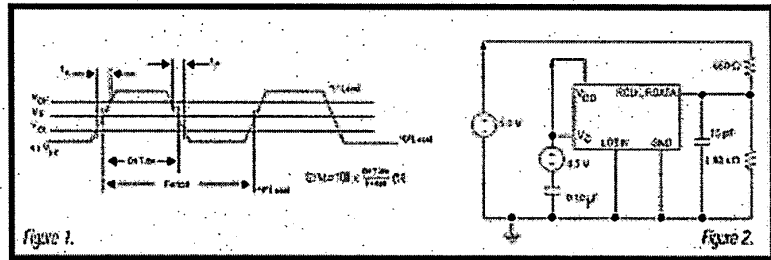

2 of 17

REPRODUCTION OF THIS DOCUMENT IS PROHIBITED WITHOUT THE WRITTEN PERMISSION OF SONY ELECTRONICS INC.

# US Patent Number: 5,946,343 Issued to Schotz

Item Number 13: Demodulator, RF2703

## RF2703

### Absolute Maximum Ratings

Parameter	Rating	Unit
Supply Voltage	-0.5 to 7.0	V <sub>DD</sub>
IF Input Level	500	mV <sub>rms</sub>
Operating Ambient Temperature	-40 to +85	°C
Storage Temperature	-40 to +150	°C

 Caution ESD sensitive device.

©1997 Sony Electronics Inc. All rights reserved. This document is the property of Sony Electronics Inc. and is not to be distributed outside the company. The information contained herein is for reference only and is not to be used for any other purpose.

7  
QUADRATURE  
DEMODULATORS

Parameter	Specification			Unit	Condition
	Min.	Typ.	Max.		
Overall					
IF Frequency Range		0.1 to 250		MHz	f = 25°C, V <sub>CC</sub> = 3.0V, IF = 100 MHz, LO = 200 MHz, F <sub>LO</sub> = 500 kHz
Baseband Frequency Range		DC to 30		MHz	For IF frequencies below ~2.5 MHz, the LO should be a square wave. IF frequencies lower than 100 kHz are optimized if the LO is a square wave and sufficiently large DC blocking capacitors are used.
Input Impedance		1200    1 pF		Ω	Each input, single-ended
LO Frequency					Twice (2x) the IF frequency. For IF frequencies below ~2.5 MHz, the LO should be a square wave. IF frequencies lower than 100 kHz are optimized if the LO is a square wave and sufficiently large DC blocking capacitors are used.
Level		0.05 to 1		V <sub>rms</sub>	
Input Impedance		500    1 pF		Ω	
Demodulator Configuration					I <sub>BIAS</sub> = 250 nA, LO = 300 mV <sub>rms</sub> , 2,040 × 1000
Output Impedance		50    1 pF		Ω	Each output, I <sub>OUT</sub> and Q <sub>OUT</sub>
Maximum Output		1.4		V <sub>rms</sub>	Saturated
Voltage Gain		20		dB	V <sub>CC</sub> = 3.0V
	22.5	24	25.1	dB	V <sub>CC</sub> = 5.0V
Noise Figure		24		dB	Single Sideband, IF input of device reactively matched
		25		dB	Single Sideband, 500 Ω shunt resistor at IF input
Input Third Order Intercept Point (IP3)		>22		dBm	V <sub>CC</sub> = 3.0V, IF input of device reactively matched
		>11		dBm	V <sub>CC</sub> = 3.0V, 500 Ω shunt resistor at IF input
		-19		dBm	V <sub>CC</sub> = 5.0V, IF input of device reactively matched
		-8		dBm	V <sub>CC</sub> = 5.0V, 500 Ω shunt resistor at IF input
		<-20		dBm	V <sub>CC</sub> = 5.0V, IF input of device reactively matched, Z <sub>LOAD</sub> = 50 Ω
IQs Amplitude Balance		0.1	0.5	dB	
Quadrature Phase Error		<±1		°	
DC Output	2.0	2.4	2.8	mV	V <sub>CC</sub> = 3.0V, I <sub>OUT</sub> and Q <sub>OUT</sub> to GND
DC Offset		<10	50	mV	V <sub>CC</sub> = 3.0V, I <sub>OUT</sub> and Q <sub>OUT</sub> to GND, I <sub>OUT</sub> to Q <sub>OUT</sub>

7-24

Rev A3.97.1028

# US Patent Number: 5,946,343 Issued to Schotz

Item Number 13: Demodulator, RF2703 continued

## RF2703

Modulator Configuration					$I_{F1} = 25 \text{ mA}$ , $I_{O} = 200 \text{ mA}$ , $Z_{load} = 125 \Omega$ Saturated Single Sideband, 1dB Gain Compression, Single Sideband
Maximum Output		200		mW	
Input Voltage		90		mV <sub>rms</sub>	
Voltage Gain		5		dB	
1dB Amplitude Distortion		0.1		dB	
Carrier Phase Error		< ±1		°	
Carrier Suppression		25		dBc	Unadjusted. Carrier Suppression may be optimized further by adjusting the DC offset level between the A and B inputs.
Sidelobe Suppression		90		dB	
Power Supply					Operating limits
Voltage		2.7 to 6		V	$V_{CC} = 3.0 \text{ V}$
Current		8		mA	$V_{CC} = 5.0 \text{ V}$
	0	10	12	mA	

7  
QUADRATURE DEMODULATORS



# US Patent Number: 5,946,343 Issued to Schotz

## Item Number 14: Microprocessor, PIC16C55

### PIC16C5X

#### 12.1 DC Characteristics: PIC16C54/55/56/57-RC, XT, 10, H0, LP (Commercial)

PIC16C54/55/56/57-RC, XT, 10, H0, LP (Commercial)			Standard Operating Conditions (unless otherwise specified) Operating Temperature: 0°C to TA ≤ +70°C for commercial				
Param. No.	Symbol	Characteristic/Device	Min	Typ <sup>1</sup>	Max	Units	Conditions
D331	VDD	Supply Voltage					
		PIC16C5X-RC	1.0	—	5.25	V	
		PIC16C5X-XT	1.0	—	5.25	V	
		PIC16C5X-10	4.5	—	5.5	V	
		PIC16C5X-HS	4.5	—	5.5	V	
PIC16C5X-LP	2.5	—	5.25	V			
D332	VDD	RAM Data Retention Voltage <sup>2)</sup>		1.5 <sup>3)</sup>	—	V	Device in SLEEP mode
D333	VDD	VDD Start Voltage to ensure Power-on Reset		VDD	—	V	See Section 5.1 for details on Power-on Reset
D334	dv/dt	VDD Rise Rate to ensure Power-on Reset	0.05 <sup>4)</sup>	—	—	V/ns	See Section 5.1 for details on Power-on Reset
D310	IDD	Supply Current <sup>2)</sup>					
		PIC16C5X-RC <sup>2)</sup>	—	3.8	3.5	mA	Freq = 4 MHz, VDD = 5.0V
		PIC16C5X-XT <sup>2)</sup>	—	3.8	3.5	mA	Freq = 4 MHz, VDD = 5.0V
		PIC16C5X-10 <sup>2)</sup>	—	4.8	10	mA	Freq = 10 MHz, VDD = 5.0V
		PIC16C5X-HS <sup>2)</sup>	—	4.8	10	mA	Freq = 10 MHz, VDD = 5.0V
		PIC16C5X-LP <sup>2)</sup>	—	9.0	20	mA	Freq = 32 kHz, VDD = 1.0V, WDT disabled
D330	IDD	Power-down Current <sup>2)</sup>	—	4.0	12	µA	VDD = 5.0V, WDT enabled
			—	0.6	9	µA	VDD = 5.0V, WDT disabled

<sup>1</sup> These parameters are characterized but not tested.

<sup>2</sup> Data in "Typ" column is based on characterization results at 25°C. This data is for design guidance only and is not tested.

Note 1: This is the time to which VDD can be lowered in SLEEP mode without losing RAM data.

Note 2: The supply current is mainly a function of the operating voltage and frequency. Other factors such as bus loading, oscillator type, bus rate, internal code execution pattern and temperature also have an impact on the current consumption.

a) The test conditions for all the measurements in active/operating mode are: OSC1 = external square wave, from RAM-ROZ at 50 pins tri-state, dV/dt = VDD, VDDH = VDD, VDDL = VDD, WDT enable/disable as specified.

b) For standby current measurements, the conditions are the same, except that the device is in SLEEP mode. The power-down current in SLEEP mode does not depend on the oscillator type.

3) Does not include current through R<sub>EXT</sub>. The current through the resistor can be estimated by the formula: I<sub>D</sub> = VDD/R<sub>EXT</sub> (mA) with R<sub>EXT</sub> in Ω.

**US Patent Number:5,946,343 Issued to Schotz**

Item Number 15: DSSS Transmitter, CYLINK SSTX

**NO DATASHEET**

**US Patent Number:5,946,343 Issued to Schotz**

Item Number 16: DSSS Receiver, CYLINK Part# SPECTRE

**NO DATASHEET**

**US Patent Number:5,946,343 Issued to Schotz**

Item Number 17: Mixer, IAM81008

**NO DATASHEET**

**US Patent Number:5,946,343 Issued to Schotz**

Item Number 18: Channel Encoder/Decoder, SRT241203

**NO DATASHEET**

**US Patent Number: 5,946,343 Issued to Schotz**

Item Number 19: Interleaver/De-interleaver, SRT-24INT

**NO DATASHEET**

**US Patent Number:5,946,343 Issued to Schotz**

Item Number 20: Optical Digital Receiver, HK-3131-01

**NO DATASHEET**

**US Patent Number:5,946,343 Issued to Schotz**

Item Number 21: Optical Digital Transmitter, HK-3131-03

**NO DATASHEET**



**US Patent Number:5,946,343 Issued to Schotz**

Item Number 22: Voltage Controlled Oscillator, M2 D300

**NO DATASHEET**

## EXHIBIT C

NOTE : A=Altstatt S=Schotz FHSS=Frequency Hopping Spread Spectrum w=with Tx=transmitter

System	Part	SupplyCurrent (in mA)	Size (in inches)	Playtime	Note
					Altstatt's Tx
A(Tx)	BA1404	3	18-pin 0.44 x 0.30		FM Stereo Transmitter
				16+ hours	Tx continuous operation time
S(Tx w SS)	DSP56002	90	144-pin 0.78 x 0.78		Schotz FHSS Tx
	>PLL	1	N/A		PLL located inside DSP56002
	>ckout	14	N/A		ckout located inside DSP56002
	SAA7360		44-pin 0.50 x 0.50		A/D converter
	>analog	43			function of the A/D converter
	>digital	50			function of the A/D converter
	SAA2520	82	44-pin 0.55 x 0.55		Stereo Filter MPEG
	SAA2521	25	44-pin 0.55 x 0.55		MPEG
	RF2422	45	16-pin 0.39 x 0.24		Modulator
	TQ9132	85	8-pin 0.19 x 0.23		Power Amp
	MC12210	10.2	16-pin 0.39 x 0.24		PLL
	SMV2500	19	12-pin 0.28 x 0.28		VCO
	HK-3131-01	no data	no data		Optical Digital Rcvr (*)
	M2 D300	no data	no data		VCO (*)
	SRT241203	no data	no data		FEC (*)
	SRT-24INT	no data	no data		Interleaver (*)
				0.1 hours or 6+ minutes	
A(Tx) equation in hours:					
$\{(60 \times 50 \text{mA} \cdot \text{minutes}) / [(60 \text{ minutes/hour} \times 24 \text{ hour/day})(3 \text{mA})]\} \times (24 \text{ hour/day}) = 16.6 \text{ hours}$					
S(Tx w SS) equation in hours:					
$\{(60 \times 50 \text{mA} \cdot \text{min.}) / [(60 \text{ min./hr} \times 24 \text{ hr/day})(90 + 1 + 14 + 43 + 50 + 82 + 25 + 45 + 85 + 10.2 + 19 \text{mA})]\} \times (24 \text{ hr/day}) = 6.4 \text{ min}$					
where min = minutes and hr = hours					
(*) = Unable to locate datasheet for integrated chip (IC) referenced by Schotz					

NOTE : A=Altstatt S=Schotz FHSS=Frequency Hopping Spread Spectrum w=with Rx=Receiver

System	Part	Supply Current (in mA)	Size (in inches)	Playtime	Note
					Altstatt's Rx
A(Rx)	TA7792	4	16-pin 0.77 x 0.30		AM/FM Tuner System
	TA7766A	0.8	18-pin 0.44 x 0.30		FM PLL
				10+ hours	Rx continuous operation time
S(Rx w SS)	DSP56002	90	144-pin 0.78 x 0.78		Schotz FHSS Rx
	>PLL	1	N/A		PLL located inside DSP56002
	>ckout	14	N/A		ckout located inside DSP56002
	MGA86576	16	4-pin 0.20 x 0.07		LNA
	HK-3131-03	no data	no data		Optical Digital Tx (*)
	CS8402	1.5	28-pin 1.20 x 0.20		Digital Interface Tx
	SAA2520	82	44-pin 0.55 x 0.55		Stereo Filter MPEG
	TDA1305T	42	28-pin 0.70 x 0.40		DAC
	TRU-050	63	16-pin 0.80 x 0.30		Clock Recovery and Timing
	RF2703	10	14-pin 0.34 x 0.24		Demodulator
	MC12210	10.2	16-pin 0.39 x 0.24		PLL
	SMV2500	19	12-pin 0.28 x 0.28		VCO
	SRT241203	no data	no data		FEC (*)
	SRT-24INT	no data	no data		De-interleaver (*)
	IAM81008	no data	no data		Mixer (*)
				0.14 hours or 8+ minutes	
A(Rx) equation in hours:					
$\{(60 \times 50 \text{mA} \cdot \text{minutes}) / [(60 \text{ minutes/hour} \times 24 \text{ hour/day})(4.8 \text{mA})]\} \times (24 \text{ hour/day})$					
S(Rx w SS) equation in hours:					
$\{(60 \times 50 \text{mA} \cdot \text{minutes}) / [(60 \text{ minutes/hour} \times 24 \text{ hour/day})(\text{sum of IC currents in mA})]\} \times (24 \text{ hour/day})$					
(*) = Unable to locate datasheet for integrated chip (IC) referenced by Schotz					

NOTE : A=Altstatt S=Schotz DSSS=Direct Sequence Spread Spectrum w=with Tx=transmitter

System	Part	Supply Current (in mA)	Size (in inches)	Playtime	Note
					Altstatt's Tx
A(Tx)	BA1404	3	18-pin 0.44 x 0.30		FM Stereo Transmitter
				16+ hours	Tx continuous operation time
S(Tx w SS)	DSP56002	90	144-pin 0.78 x 0.78		Schotz DSSS Tx
	>PLL	1	N/A		PLL located inside DSP56002
	>ckout	14	N/A		ckout located inside DSP56002
	PIC16C55	1.8	28-pin 1.5 x 0.50		Microprocessor
	SAA7360		44-pin 0.50 x 0.50		A/D converter
	>analog	43			function of the A/D converter
	>digital	50			function of the A/D converter
	RF2422	45	16-pin 0.39 x 0.24		Modulator
	MC12210	10.2	16-pin 0.39 x 0.24		PLL
	SMV2500	19	12-pin 0.28 x 0.28		VCO
	CYLINK SSTS	no data	no data		DSSS Transmitter (*)
	HK-3131-01	no data	no data		Optical Digital Rcvr (*)
	M2 D300	no data	no data		VCO (*)
				0.18 hours or 11 minutes	
A(Tx) equation in hours:					
$\{(60 \times 50 \text{mA} \cdot \text{minutes}) / ((60 \text{ minutes/hour} \times 24 \text{ hour/day})(3 \text{mA}))\} \times (24 \text{ hour/day})$					
S(Tx w SS) equation in hours:					
$\{(60 \times 50 \text{mA} \cdot \text{minutes}) / ((60 \text{ minutes/hour} \times 24 \text{ hour/day})(\text{sum of IC currents in mA}))\} \times (24 \text{ hour/day})$					
(*) = Unable to locate datasheet for integrated chip (IC) referenced by Schotz					

NOTE : A=Altstatt S=Schotz DSSS=Direct Sequence Spread Spectrum w=with Rx=Receiver

System	Part	Supply Current (in mA)	Size (in inches)	Playtime	Note
					Altstatt's Rx
A(Rx)	TA7792	4	16-pin 0.77 x 0.30		AM/FM Tuner System
	TA7766A	0.8	18-pin 0.44 x 0.30		FM PLL
				10+ hours	Rx continuous operation time
S(Rx w SS)	DSP56002	90	144-pin 0.78 x 0.78		Schotz DSSS Rx
	>PLL	1	N/A		PLL located inside DSP56002
	>ckout	14	N/A		ckout located inside DSP56002
	PIC16C55	1.8	28-pin 1.5 x 0.50		Microprocessor
	CYLINK	no data	no data		DSSS Receiver
	MGA86576	16	4-pin 0.20 x 0.07		LNA
	IAM81008	no data	no data		Mixer (*)
	CS8402	1.5	28-pin 1.20 x 0.20		Digital Interface Tx
	TDA1305T	42	28-pin 0.70 x 0.40		DAC
	MC12210	10.2	16-pin 0.39 x 0.24		PLL
	SMV2500	19	12-pin 0.28 x 0.28		VCO
	HK-3131-03	no data	no data		Optical Digital Tx (*)
				0.25 hours or 15 minutes	
A(Rx) equation in hours:					
$\{(60 \times 50 \text{mA} \cdot \text{minutes}) / [(60 \text{ minutes/hour} \times 24 \text{ hour/day})(4.8 \text{mA})]\} \times (24 \text{ hour/day})$					
S(Rx w SS) equation in hours:					
$\{(60 \times 50 \text{mA} \cdot \text{minutes}) / [(60 \text{ minutes/hour} \times 24 \text{ hour/day})(\text{sum of IC currents in mA})]\} \times (24 \text{ hour/day})$					
(*) = Unable to locate datasheet for integrated chip (IC) referenced by Schotz					

EXHIBIT D

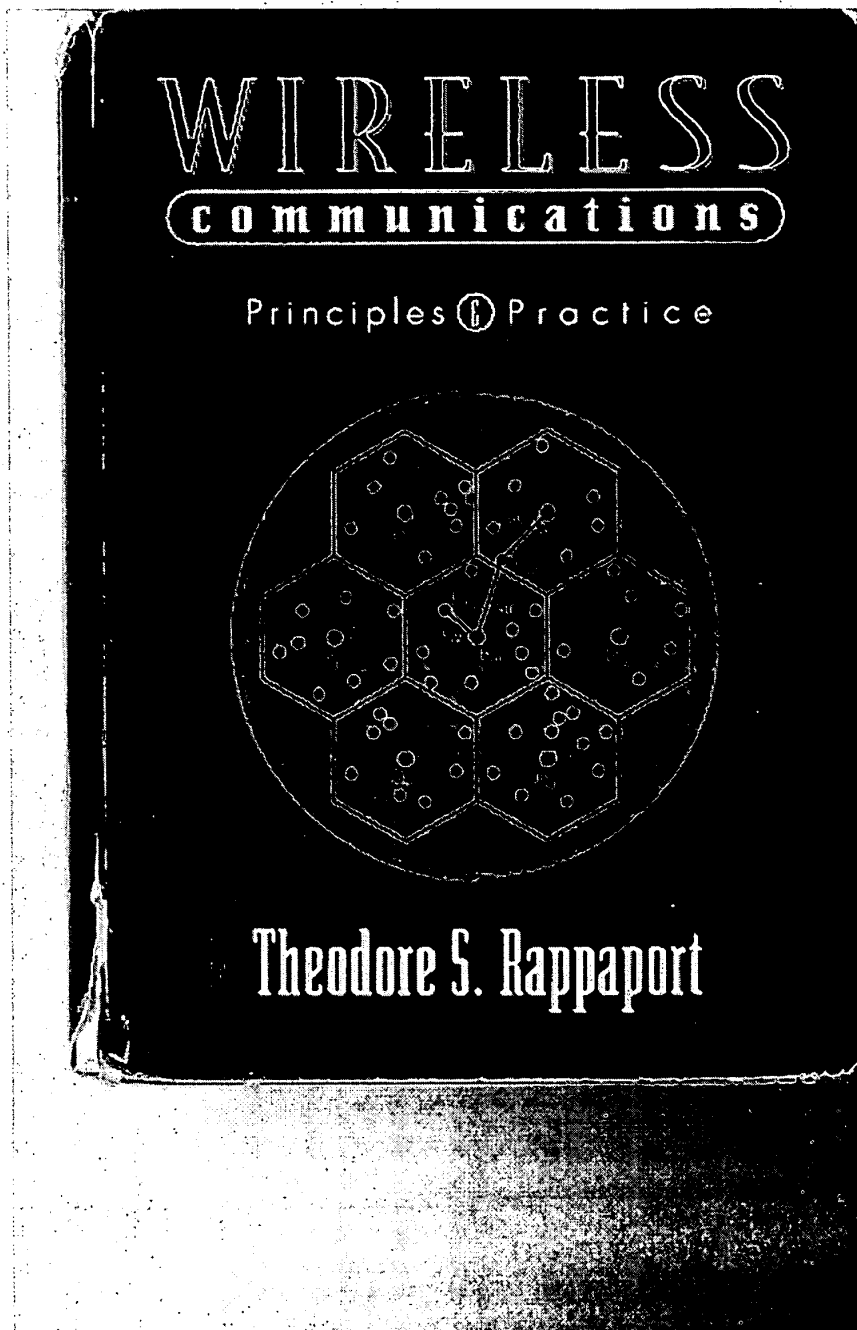

microcellular systems. However, satellite mobile systems offer tremendous promise for paging, data collection, and emergency communications, as well as for global roaming before IMT-2000 is deployed. In early 1990, the aerospace industry demonstrated the first successful launch of a small satellite on a rocket from a jet aircraft. This launch technique is more than an order of magnitude less expensive than conventional ground-based launches and can be deployed quickly, suggesting that a network of LEOs could be rapidly deployed for wireless communications around the globe. Already, several companies have proposed systems and service concepts for worldwide paging, cellular telephone, and emergency navigation and notification [IEE91].

In emerging nations, where existing telephone service is almost nonexistent, fixed cellular telephone systems are being installed at a rapid rate. This is due to the fact that developing nations are finding it is quicker and more affordable to install cellular telephone systems for fixed home use, rather than install wires in neighborhoods which have not yet received telephone connections to the PSTN.

The world is now in the early stages of a major telecommunications revolution that will provide ubiquitous communication access to citizens, wherever they are [Kuc91], [Goo91], [ITU94]. This new field requires engineers who can design and develop new wireless systems, make meaningful comparisons of competing systems, and understand the engineering trade-offs that must be made in any system. Such understanding can only be achieved by mastering the fundamental technical concepts of wireless personal communications. These concepts are the subject of the remaining chapters of this text.

### 1.6 Problems

- 1.1 Why do paging systems need to provide low data rates? How does a low data rate lead to better coverage?
- 1.2 Qualitatively describe how the power supply requirements differ between mobile and portable cellular phones, as well as the difference between pocket pagers and cordless phones. How does coverage range impact battery life in a mobile radio system?
- 1.3 In simulcasting paging systems, there usually is one dominant signal arriving at the paging receiver. In most, but not all cases, the dominant signal arrives from the transmitter closest to the paging receiver. Explain how the FM capture effect could help reception of the paging receiver. Could the FM capture effect help cellular radio systems? Explain how.
- 1.4 Where would walkie-talkies fit in Tables 1.5 and 1.6? Carefully describe the similarities and differences between walkie-talkies and cordless telephones. Why would consumers expect a much higher grade of service for a cordless telephone system?
- 1.5 Assume a 1 Amp-hour battery is used on a cellular telephone (often called a cellular subscriber unit). Also assume that the phone's radio receiver draws 35 mA on receive and 250 mA during a call. How long would the phone work (i.e. what is the battery life) if the user has one 3-minute call every day? every 6

- hours? every hour? What is the maximum talk time available on the cellular phone in this example?
- 1.6 Assume a CT2 subscriber unit has the same size battery as the phone in Problem 1.5, but the paging receiver draws 5 mA and the transmitter draws 80 mA during a call. Recompute the battery life for the cases in Problem 1.5. Recompute the maximum talk time for the CT2 handset.
  - 1.7 Why would one expect the CT2 handset in Problem 1.6 to have a smaller battery drain during transmission than a cellular telephone?
  - 1.8 Why is FM, rather than AM, used in most mobile radio systems today? List as many reasons as you can think of, and justify your responses. Consider issues such as fidelity, power consumption, and noise.
  - 1.9 List the factors that led to the development of (a) the GSM system for Europe, and (b) the U.S. digital cellular system. How important was it for both efforts to (i) maintain compatibility with existing cellular phones? (ii) obtain spectral efficiency? (iii) obtain new radio spectrum?
  - 1.10 Assume that a GSM, an IS-95, and a U.S. digital cellular base station transmit the same power over the same distance. Which system will provide the best SNR at a mobile receiver? How much is the improvement over the other two systems? Assume a perfect receiver with only thermal noise is used for each of the three systems.
  - 1.11 Discuss the similarities and difference between a conventional cellular radio system and a space-based cellular radio system. What are the advantages and disadvantages of each system? Which system could support a larger number of users for a given frequency allocation? How would this impact the cost of service for each subscriber?
  - 1.12 Assume that wireless communication services can be classified as belonging to one of the following four groups:
    - High power, wide area systems (cellular)
    - Low power, local area systems (cordless telephone and PCS)
    - Low speed, wide area systems (mobile data)
    - High speed, local area systems (wireless LANs)Classify each of the wireless systems described in Chapter 1 using these four groups. Justify your answers. Note that some systems may fit into more than one group.
  - 1.13 Discuss the importance of regional and international standards organizations such as ITU-R, ETSI, and WARC. What competitive advantages are there in using different wireless standards in different parts of the world? What disadvantages arise when different standards and different frequencies are used in different parts of the world?
  - 1.14 Based on the proliferation of wireless standards throughout the world, discuss how likely it is for IMT-2000 to be adopted. Provide a detailed explanation, along with probable scenarios of services, spectrum allocations, and cost.



Solutions Manual to Accompany

**Wireless Communications  
Principles and Practices**

FIRST EDITION

Zhigang Rong

Theodore S. Rappaport



Prentice Hall PTR  
Upper Saddle River, New Jersey 07458

Cont'd

infrastructure, complexity, hardware cost are all low.

A cordless telephone, on the other hand, is a full duplex system. It allows simultaneous two-way communication. Transmission and reception is on two different channels (FDD) although new cordless systems are using TDD. The coverage range, required infrastructure, hardware cost of a cordless phone system are low and the complexity is moderate. Their operations are better for a cordless telephone.

1.5 If the user has one 3-minute call every day:

$$\text{the battery life} = \frac{60 \times 1000 \text{ (mAh)}}{(60 \times 3) \times 25 + 3 \times 250 \text{ (mA-min)}} \\ = 1.175 \text{ days} = \underline{\underline{28.2 \text{ hours}}}$$

If the user has one 3-minute call every 6 hours:

$$\text{the battery life} = \frac{60 \times 1000}{(60 \times 3) \times 25 + 3 \times 250} \times 6 = \underline{\underline{27.18 \text{ hours}}}$$

If the user has one 3-minute call every hour:

$$\text{the battery life} = \frac{60 \times 1000}{(60 \times 3) \times 25 + 3 \times 250} = \underline{\underline{21.86 \text{ hours}}}$$

$$\text{the maximum talk time} = \frac{60 \times 1000}{250} = 240 \text{ minutes} = \underline{\underline{4 \text{ hours}}}$$

1.6 For 3-minute call/day

$$\text{battery life} = \frac{60 \times 1000 \text{ (mAh)}}{(60 \times 3) \times 25 + 3 \times 250} = 8.08 \text{ days} = \underline{\underline{193.94 \text{ hours}}}$$

1.6 Cont'd

For 3-minute-call/6 hours.

$$\text{battery life} = \frac{60 \times 1000}{(60 \times 3) \times 25 + 3 \times 250} \times 6 = \underline{\underline{177.78 \text{ hours}}}$$

For 3-minute-call/hour.

$$\text{battery life} = \frac{60 \times 1000}{(60 \times 3) \times 25 + 3 \times 250} = \underline{\underline{119.29 \text{ hours}}}$$

$$\text{The maximum talk time} = \frac{60 \times 1000}{250} = 750 \text{ minutes} = \underline{\underline{12.5 \text{ hours}}}$$

1.7 Since the coverage range of the CT-2 system is lower than that of the cellular radio system, to obtain the same signal-to-noise ratios in the coverage area, a CT-2 handset requires less transmitted power than a cellular telephone, and thus a smaller battery drain.

1.8 FM has several advantages over AM. The most important advantage is FM's superior noise suppression characteristics. With conventional AM, the modulating signal is impressed onto the carrier in the form of amplitude variations. However, noise introduced into the system also produces changes in the amplitude of the envelope. Therefore, the noise cannot be removed from the composite waveform without also removing a portion of the information signal. With FM, the information is impressed onto the carrier in the form of frequency variations. Therefore, with FM receivers,

**This Page is Inserted by IFW Indexing and Scanning  
Operations and is not part of the Official Record**

**BEST AVAILABLE IMAGES**

Defective images within this document are accurate representations of the original documents submitted by the applicant.

Defects in the images include but are not limited to the items checked:

- BLACK BORDERS
- IMAGE CUT OFF AT TOP, BOTTOM OR SIDES
- FADED TEXT OR DRAWING
- BLURRED OR ILLEGIBLE TEXT OR DRAWING
- SKEWED/SLANTED IMAGES
- COLOR OR BLACK AND WHITE PHOTOGRAPHS
- GRAY SCALE DOCUMENTS
- LINES OR MARKS ON ORIGINAL DOCUMENT
- REFERENCE(S) OR EXHIBIT(S) SUBMITTED ARE POOR QUALITY
- OTHER: \_\_\_\_\_

**IMAGES ARE BEST AVAILABLE COPY.**

**As rescanning these documents will not correct the image problems checked, please do not report these problems to the IFW Image Problem Mailbox.**

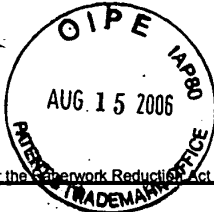

8-16-06

DFW/K  
c-c

Approved for use through 09/30/2006. OMB 0651-0031  
U.S. Patent and Trademark Office; U.S. DEPARTMENT OF COMMERCE

Under the Paperwork Reduction Act of 1995, no persons are required to respond to a collection of information unless it displays a valid OMB control number.

<b>TRANSMITTAL FORM</b>  <small>(to be used for all correspondence after initial filing)</small>	Application Number	10/648, 012
	Filing Date	08/26/2003
	First Named Inventor	Woolfork, C. Earl
	Art Unit	2615
	Examiner Name	Flanders, Andrew C.
	Attorney Docket Number	W003-4000
Total Number of Pages in This Submission		

ENCLOSURES (Check all that apply)		
<input checked="" type="checkbox"/> Fee Transmittal Form <input type="checkbox"/> Fee Attached  <input checked="" type="checkbox"/> Amendment/Reply <input type="checkbox"/> After Final <input checked="" type="checkbox"/> Affidavits/declaration(s)  <input type="checkbox"/> Extension of Time Request <input type="checkbox"/> Express Abandonment Request <input type="checkbox"/> Information Disclosure Statement  <input type="checkbox"/> Certified Copy of Priority Document(s) <input type="checkbox"/> Reply to Missing Parts/Incomplete Application <input type="checkbox"/> Reply to Missing Parts under 37 CFR 1.52 or 1.53	<input type="checkbox"/> Drawing(s) <input type="checkbox"/> Licensing-related Papers  <input type="checkbox"/> Petition <input type="checkbox"/> Petition to Convert to a Provisional Application <input type="checkbox"/> Power of Attorney, Revocation <input type="checkbox"/> Change of Correspondence Address <input type="checkbox"/> Terminal Disclaimer <input type="checkbox"/> Request for Refund <input type="checkbox"/> CD, Number of CD(s) _____ <input type="checkbox"/> Landscape Table on CD	<input type="checkbox"/> After Allowance Communication to TC <input type="checkbox"/> Appeal Communication to Board of Appeals and Interferences <input type="checkbox"/> Appeal Communication to TC (Appeal Notice, Brief, Reply Brief) <input type="checkbox"/> Proprietary Information <input type="checkbox"/> Status Letter <input checked="" type="checkbox"/> Other Enclosure(s) (please identify below): Credit Card Payment Form PTO-2038
Remarks Attached herewith are Exhibits 1, 2, 3, 4, 5 (including Exhibit A), and 6 (including Exhibits A-D). EXPRESS MAIL LABEL NO.: ET 615079096 US		

SIGNATURE OF APPLICANT, ATTORNEY, OR AGENT			
Firm Name	The Patel Law Firm, P.C.		
Signature			
Printed name	Natu J. Patel		
Date	08/15/2006	Reg. No.	39,559

CERTIFICATE OF TRANSMISSION/MAILING			
I hereby certify that this correspondence is being facsimile transmitted to the USPTO or deposited with the United States Postal Service with sufficient postage as first class mail in an envelope addressed to: Commissioner for Patents, P.O. Box 1450, Alexandria, VA 22313-1450 on the date shown below:			
Signature			
Typed or printed name	Natu J. Patel	Date	08/15/2006

This collection of information is required by 37 CFR 1.5. The information is required to obtain or retain a benefit by the public which is to file (and by the USPTO to process) an application. Confidentiality is governed by 35 U.S.C. 122 and 37 CFR 1.11 and 1.14. This collection is estimated to 2 hours to complete, including gathering, preparing, and submitting the completed application form to the USPTO. Time will vary depending upon the individual case. Any comments on the amount of time you require to complete this form and/or suggestions for reducing this burden, should be sent to the Chief Information Officer, U.S. Patent and Trademark Office, U.S. Department of Commerce, P.O. Box 1450, Alexandria, VA 22313-1450. DO NOT SEND FEES OR COMPLETED FORMS TO THIS ADDRESS. SEND TO: Commissioner for Patents, P.O. Box 1450, Alexandria, VA 22313-1450.

If you need assistance in completing the form, call 1-800-PTO-9199 and select option 2.

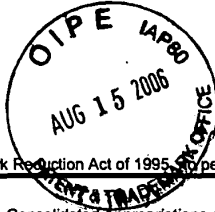

PTO/SB/17 (01-06)

Approved for use through 07/31/2006. OMB 0651-0032  
U.S. Patent and Trademark Office; U.S. DEPARTMENT OF COMMERCE

Under the Paperwork Reduction Act of 1995, no persons are required to respond to a collection of information unless it displays a valid OMB control number

<b>FEE TRANSMITTAL</b> <b>For FY 2006</b>		<b>Complete if Known</b>	
		Application Number	10/648, 012
<input checked="" type="checkbox"/> Applicant claims small entity status. See 37 CFR 1.27		Filing Date	08/26/2003
<b>TOTAL AMOUNT OF PAYMENT</b> (\$) 2100.00		First Named Inventor	Woolfork, C. Earl
		Examiner Name	Flanders, Andrew C.
		Art Unit	2615
		Attorney Docket No.	W003-4000

**METHOD OF PAYMENT** (check all that apply)

Check 
  Credit Card 
  Money Order 
  None 
  Other (please identify): \_\_\_\_\_

Deposit Account Deposit Account Number: \_\_\_\_\_ Deposit Account Name: \_\_\_\_\_

For the above-identified deposit account, the Director is hereby authorized to: (check all that apply)

Charge fee(s) indicated below 
  Charge fee(s) indicated below, except for the filing fee

Charge any additional fee(s) or underpayments of fee(s) under 37 CFR 1.16 and 1.17 
  Credit any overpayments

**WARNING:** Information on this form may become public. Credit card information should not be included on this form. Provide credit card information and authorization on PTO-2038.

**FEE CALCULATION (All the fees below are due upon filing or may be subject to a surcharge.)**

**1. BASIC FILING, SEARCH, AND EXAMINATION FEES**

Application Type	FILING FEES		SEARCH FEES		EXAMINATION FEES		Fees Paid (\$)
	Fee (\$)	Small Entity Fee (\$)	Fee (\$)	Small Entity Fee (\$)	Fee (\$)	Small Entity Fee (\$)	
Utility	300	150	500	250	200	100	_____
Design	200	100	100	50	130	65	_____
Plant	200	100	300	150	160	80	_____
Reissue	300	150	500	250	600	300	_____
Provisional	200	100	0	0	0	0	_____

**2. EXCESS CLAIM FEES**

Fee Description	Fee (\$)	Small Entity Fee (\$)
Each claim over 20 (including Reissues)	50	25
Each independent claim over 3 (including Reissues)	200	100
Multiple dependent claims	360	180

**Total Claims**      **Extra Claims**      **Fee (\$)**      **Fee Paid (\$)**  
 53 - 20 or HP = 40 x 25 = 1000.00

HP = highest number of total claims paid for, if greater than 20.

**Indep. Claims**      **Extra Claims**      **Fee (\$)**      **Fee Paid (\$)**  
 19 - 3 or HP = 11 x 100 = 1100.00

HP = highest number of independent claims paid for, if greater than 3.

**3. APPLICATION SIZE FEE**

If the specification and drawings exceed 100 sheets of paper (excluding electronically filed sequence or computer listings under 37 CFR 1.52(e)), the application size fee due is \$250 (\$125 for small entity) for each additional 50 sheets or fraction thereof. See 35 U.S.C. 41(a)(1)(G) and 37 CFR 1.16(s).

Total Sheets	Extra Sheets	Number of each additional 50 or fraction thereof	Fee (\$)	Fee Paid (\$)
_____	_____	_____	_____	_____

\_\_\_\_\_ - 100 = \_\_\_\_\_ / 50 = \_\_\_\_\_ (round up to a whole number) x \_\_\_\_\_ = \_\_\_\_\_

**4. OTHER FEE(S)**

Non-English Specification, \$130 fee (no small entity discount)      **Fees Paid (\$)** \_\_\_\_\_

Other (e.g., late filing surcharge): \_\_\_\_\_

<b>SUBMITTED BY</b>		
Signature		Registration No. (Attorney/Agent) 39,559
Name (Print/Type)	Natu J. Patel	Telephone (949) 955-1077
		Date 08/15/2006

This collection of information is required by 37 CFR 1.136. The information is required to obtain or retain a benefit by the public which is to file (and by the USPTO to process) an application. Confidentiality is governed by 35 U.S.C. 122 and 37 CFR 1.14. This collection is estimated to take 30 minutes to complete, including gathering, preparing, and submitting the completed application form to the USPTO. Time will vary depending upon the individual case. Any comments on the amount of time you require to complete this form and/or suggestions for reducing this burden, should be sent to the Chief Information Officer, U.S. Patent and Trademark Office, U.S. Department of Commerce, P.O. Box 1450, Alexandria, VA 22313-1450. DO NOT SEND FEES OR COMPLETED FORMS TO THIS ADDRESS. SEND TO: Commissioner for Patents, P.O. Box 1450, Alexandria, VA 22313-1450.

*If you need assistance in completing the form, call 1-800-PTO-9199 and select option 2.*

**PATENT APPLICATION FEE DETERMINATION RECORD**  
Effective January 1, 2003

Application or Docket Number

10/648012

**CLAIMS AS FILED - PART I**

	(Column 1)	(Column 2)
TOTAL CLAIMS	5	
FOR	NUMBER FILED	NUMBER EXTRA
TOTAL CHARGEABLE CLAIMS	5 minus 20 = *	0
INDEPENDENT CLAIMS	3 minus 3 = *	0
MULTIPLE DEPENDENT CLAIM PRESENT <input type="checkbox"/>		

\* If the difference in column 1 is less than zero, enter "0" in column 2

**CLAIMS AS AMENDED - PART II**

8/15/06

	(Column 1)	(Column 2)	(Column 3)
AMENDMENT A	CLAIMS REMAINING AFTER AMENDMENT	HIGHEST NUMBER PREVIOUSLY PAID FOR	PRESENT EXTRA
	Total	* 48 Minus ** 20	= 28
	Independent	* 19 Minus *** 10	= 9
FIRST PRESENTATION OF MULTIPLE DEPENDENT CLAIM <input type="checkbox"/>			

SMALL ENTITY TYPE  OR OTHER THAN SMALL ENTITY

RATE	FEE	OR	RATE	FEE
BASIC FEE	375.00		BASIC FEE	750.00
X\$ 9=		OR	X\$18=	
X42=		OR	X84=	
+140=		OR	+280=	
TOTAL	375	OR	TOTAL	

SMALL ENTITY OR OTHER THAN SMALL ENTITY

RATE	ADDITIONAL FEE	OR	RATE	ADDITIONAL FEE
X\$ 9=	700	OR	X\$18=	
X42=	900	OR	X84=	
+140=		OR	+280=	
TOTAL ADDIT. FEE	1100	OR	TOTAL ADDIT. FEE	

	(Column 1)	(Column 2)	(Column 3)
AMENDMENT B	CLAIMS REMAINING AFTER AMENDMENT	HIGHEST NUMBER PREVIOUSLY PAID FOR	PRESENT EXTRA
	Total	* Minus **	=
	Independent	* Minus ***	=
FIRST PRESENTATION OF MULTIPLE DEPENDENT CLAIM <input type="checkbox"/>			

RATE	ADDITIONAL FEE	OR	RATE	ADDITIONAL FEE
X\$ 9=		OR	X\$18=	
X42=		OR	X84=	
+140=		OR	+280=	
TOTAL ADDIT. FEE		OR	TOTAL ADDIT. FEE	

	(Column 1)	(Column 2)	(Column 3)
AMENDMENT C	CLAIMS REMAINING AFTER AMENDMENT	HIGHEST NUMBER PREVIOUSLY PAID FOR	PRESENT EXTRA
	Total	* Minus **	=
	Independent	* Minus ***	=
FIRST PRESENTATION OF MULTIPLE DEPENDENT CLAIM <input type="checkbox"/>			

RATE	ADDITIONAL FEE	OR	RATE	ADDITIONAL FEE
X\$ 9=		OR	X\$18=	
X42=		OR	X84=	
+140=		OR	+280=	
TOTAL ADDIT. FEE		OR	TOTAL ADDIT. FEE	

\* If the entry in column 1 is less than the entry in column 2, write "0" in column 3.  
 \*\* If the "Highest Number Previously Paid For" IN THIS SPACE is less than 20, enter "20."  
 \*\*\* If the "Highest Number Previously Paid For" IN THIS SPACE is less than 3, enter "3."  
 The "Highest Number Previously Paid For" (Total or Independent) is the highest number found in the appropriate box in column 1.



UNITED STATES PATENT AND TRADEMARK OFFICE

UNITED STATES DEPARTMENT OF COMMERCE  
 United States Patent and Trademark Office  
 Address: COMMISSIONER FOR PATENTS  
 P.O. Box 1450  
 Alexandria, Virginia 22313-1450  
 www.uspto.gov



Bib Data Sheet

CONFIRMATION NO. 3337

<b>SERIAL NUMBER</b> 10/648,012	<b>FILING OR 371(c) DATE</b> 08/26/2003 <b>RULE</b>	<b>CLASS</b> 700	<b>GROUP ART UNIT</b> 2615	<b>ATTORNEY DOCKET NO.</b> W003-4000	
<b>APPLICANTS</b> C. Earl Woolfork, Pasadena, CA;					
** CONTINUING DATA ***** This application is a CIP of 10/027,391 12/21/2001 ABN					
** FOREIGN APPLICATIONS *****					
IF REQUIRED, FOREIGN FILING LICENSE GRANTED** SMALL ENTITY ** ** 11/18/2003					
Foreign Priority claimed 35 USC 119 (a-d) conditions met Verified and Acknowledged	<input type="checkbox"/> yes <input type="checkbox"/> no <input type="checkbox"/> yes <input type="checkbox"/> no <input type="checkbox"/> Met after Allowance Examiner's Signature _____ Initials _____	<b>STATE OR COUNTRY</b> CA	<b>SHEETS DRAWING</b> 2	<b>TOTAL CLAIMS</b> 5	<b>INDEPENDENT CLAIMS</b> 3
<b>ADDRESS</b> The Patel Law Firm, P.C. 2532 Dupont Drive Irvine, CA92612					
<b>TITLE</b> WIRELESS DIGITAL AUDIO SYSTEM					
<b>FILING FEE RECEIVED</b> 3075	FEES: Authority has been given in Paper No. _____ to charge/credit DEPOSIT ACCOUNT No. _____ for following:		<input type="checkbox"/> All Fees <input type="checkbox"/> 1.16 Fees ( Filing ) <input type="checkbox"/> 1.17 Fees ( Processing Ext. of time ) <input type="checkbox"/> 1.18 Fees ( Issue ) <input type="checkbox"/> Other _____ <input type="checkbox"/> Credit		



PTO/SB/122 (01-06)

Approved for use through 12/31/2008. OMB 0651-0035

U.S. Patent and Trademark Office; U.S. DEPARTMENT OF COMMERCE

Under the Paperwork Reduction Act of 1995, no persons are required to respond to a collection of information unless it displays a valid OMB control number.

## CHANGE OF CORRESPONDENCE ADDRESS *Application*

Address to:  
Commissioner for Patents  
P.O. Box 1450  
Alexandria, VA 22313-1450

Application Number	10/648,012
Filing Date	8/26/03
First Named Inventor	Woolfork, C. Earl
Art Unit	2615
Examiner Name	Flanders, Andrew
Attorney Docket Number	W003-4000

Please change the Correspondence Address for the above-identified patent application to:

The address associated with Customer Number: 48162

OR

Firm or Individual Name

Address

City

State

Zip

Country

Telephone

Email

This form cannot be used to change the data associated with a Customer Number. To change the data associated with an existing Customer Number use "Request for Customer Number Data Change" (PTO/SB/124).

I am the:

- Applicant/Inventor
- Assignee of record of the entire interest.  
Statement under 37 CFR 3.73(b) is enclosed. (Form PTO/SB/96).
- Attorney or agent of record. Registration Number 39,559
- Registered practitioner named in the application transmittal letter in an application without an executed oath or declaration. See 37 CFR 1.33(a)(1). Registration Number \_\_\_\_\_

Signature

Typed or Printed Name Natu J. Patel

Date 9/14/06

Telephone (949) 955-1077

NOTE: Signatures of all the inventors or assignees of record of the entire interest or their representative(s) are required. Submit multiple forms if more than one signature is required, see below\*.

\*Total of \_\_\_\_\_ forms are submitted.

This collection of information is required by 37 CFR 1.33. The information is required to obtain or retain a benefit by the public which is to file (and by the USPTO to process) an application. Confidentiality is governed by 35 U.S.C. 122 and 37 CFR 1.11 and 1.14. This collection is estimated to take 3 minutes to complete, including gathering, preparing, and submitting the completed application form to the USPTO. Time will vary depending upon the individual case. Any comments on the amount of time you require to complete this form and/or suggestions for reducing this burden, should be sent to the Chief Information Officer, U.S. Patent and Trademark Office, U.S. Department of Commerce, P.O. Box 1450, Alexandria, VA 22313-1450. DO NOT SEND FEES OR COMPLETED FORMS TO THIS ADDRESS. **SEND TO: Commissioner for Patents, P.O. Box 1450, Alexandria, VA 22313-1450.**

If you need assistance in completing the form, call 1-800-PTO-9199 and select option 2.



## EAST Search History

Ref #	Hits	Search Query	DBs	Default Operator	Plurals	Time Stamp
L1	0	("10648012").PN.	US-PGPUB; USPAT	OR	OFF	2006/09/25 09:26
L2	1	("5946343").PN.	US-PGPUB; USPAT	OR	OFF	2006/09/25 09:50
L3	422	(455/564.1,412,413).CCLS.	US-PGPUB; USPAT	OR	OFF	2006/09/25 09:50
L4	5294	(375/219,295-297,346,348).CCLS.	US-PGPUB; USPAT	OR	OFF	2006/09/25 10:02
L5	1	("20040223622").PN.	US-PGPUB; USPAT	OR	OFF	2006/09/25 10:04
L6	1	("5946343").PN.	US-PGPUB; USPAT	OR	OFF	2006/09/25 10:05
S1	9	FHSS with unique with user	US-PGPUB; USPAT	OR	OFF	2006/09/25 09:26
S2	6	S1 and @ad<"20011221"	US-PGPUB; USPAT	OR	OFF	2006/05/02 17:45
S3	0	FHSS with unique adj hop	US-PGPUB; USPAT	OR	OFF	2006/05/02 17:46
S4	0	FHSS with each adj user	US-PGPUB; USPAT	OR	OFF	2006/05/02 17:46
S5	0	FHSS with individual adj user	US-PGPUB; USPAT	OR	OFF	2006/05/02 17:47
S6	0	(FHSS or "frequency hopping spread spectrum") with individual adj user	US-PGPUB; USPAT	OR	OFF	2006/05/02 17:47
S7	0	(FHSS or "frequency hopping spread spectrum") near user same unique	US-PGPUB; USPAT	OR	OFF	2006/05/02 17:47
S8	9	(FHSS or "frequency hopping spread spectrum") with user same unique	US-PGPUB; USPAT	OR	OFF	2006/05/02 17:48
S9	17	(FHSS or "frequency hopping spread spectrum") same unique same user	US-PGPUB; USPAT	OR	OFF	2006/05/02 17:48
S10	6	S9 and @ad<"20011221"	US-PGPUB; USPAT	OR	OFF	2006/05/02 17:48
S11	9	(FHSS or "frequency hopping spread spectrum") same multiple adj user!	US-PGPUB; USPAT	OR	OFF	2006/05/03 10:32
S12	91	(FHSS or "frequency hopping spread spectrum") same (pn or "hopping code")	US-PGPUB; USPAT	OR	OFF	2006/05/02 17:50
S13	13	(FHSS or "frequency hopping spread spectrum") with ("hopping code")	US-PGPUB; USPAT	OR	OFF	2006/05/02 17:50
S14	3	S13 and @ad<"20011221"	US-PGPUB; USPAT	OR	OFF	2006/05/02 17:51

## EAST Search History

S15	1	("5946343").PN.	US-PGPUB; USPAT	OR	OFF	2006/05/03 11:46
S16	1	("6342844").PN.	US-PGPUB; USPAT	OR	OFF	2006/05/03 11:46
S17	1	("5771441").PN.	US-PGPUB; USPAT	OR	OFF	2006/08/28 15:55
S18	10725	"rechargeable battery" and @ad<"20011220"	US-PGPUB; USPAT	OR	OFF	2006/08/28 15:55
S19	376	"rechargeable battery".ti. and @ad<"20011220"	US-PGPUB; USPAT	OR	OFF	2006/08/28 15:55
S20	17	("rechargeable battery" and portable).ti. and @ad<"20011220"	US-PGPUB; USPAT	OR	OFF	2006/08/28 15:57
S21	3623043	("rechargeable battery" and portable) with mah andd @ad<"20011220"	US-PGPUB; USPAT	OR	OFF	2006/08/28 15:57
S22	0	("rechargeable battery" and portable) with mah and @ad<"20011220"	US-PGPUB; USPAT	OR	OFF	2006/08/28 15:57
S23	3623041	("rechargeable battery" and portable) with ma-h andd @ad<"20011220"	US-PGPUB; USPAT	OR	OFF	2006/08/28 15:57
S24	3623041	("rechargeable battery" and portable) with "ma-h" andd @ad<"20011220"	US-PGPUB; USPAT	OR	OFF	2006/08/28 15:57
S25	0	("rechargeable battery" and portable) with "ma-h" and @ad<"20011220"	US-PGPUB; USPAT	OR	OFF	2006/08/28 15:57
S26	640693	("rechargeable battery" and portable) with milliamp hours and @ad<"20011220"	US-PGPUB; USPAT	OR	OFF	2006/08/28 15:57
S27	18	("rechargeable battery" and portable) and "milliamp hours" and @ad<"20011220"	US-PGPUB; USPAT	OR	OFF	2006/08/31 12:17
S28	29	"5491839"	US-PGPUB; USPAT	OR	OFF	2006/08/30 12:56
S29	1	("5491839").PN.	US-PGPUB; USPAT	OR	OFF	2006/08/30 12:56
S30	1	("5771441").PN.	US-PGPUB; USPAT	OR	OFF	2006/08/30 12:56
S31	1	("6,107,147").PN.	US-PGPUB; USPAT	OR	OFF	2006/08/31 12:17



UNITED STATES PATENT AND TRADEMARK OFFICE

M-L

UNITED STATES DEPARTMENT OF COMMERCE  
United States Patent and Trademark Office  
Address: COMMISSIONER FOR PATENTS  
P.O. Box 1450  
Alexandria, Virginia 22313-1450  
www.uspto.gov

APPLICATION NO.	FILING DATE	FIRST NAMED INVENTOR	ATTORNEY DOCKET NO.	CONFIRMATION NO.
10/648,012	08/26/2003	C. Earl Woolfork	W003-4000	3337

48162 7590 10/02/2006  
THE PATEL LAW FIRM, P.C.  
2532 DUPONT DRIVE  
IRVINE, CA 92612

EXAMINER

FLANDERS, ANDREW C

ART UNIT PAPER NUMBER

2615

DATE MAILED: 10/02/2006

Please find below and/or attached an Office communication concerning this application or proceeding.

<b>Office Action Summary</b>	<b>Application No.</b>	<b>Applicant(s)</b>	
	10/648,012	WOOLFORK, C. EARL	
	<b>Examiner</b>	<b>Art Unit</b>	
	Andrew C. Flanders	2615	

-- The MAILING DATE of this communication appears on the cover sheet with the correspondence address --

**Period for Reply**

A SHORTENED STATUTORY PERIOD FOR REPLY IS SET TO EXPIRE 3 MONTH(S) OR THIRTY (30) DAYS, WHICHEVER IS LONGER, FROM THE MAILING DATE OF THIS COMMUNICATION.

- Extensions of time may be available under the provisions of 37 CFR 1.136(a). In no event, however, may a reply be timely filed after SIX (6) MONTHS from the mailing date of this communication.
- If NO period for reply is specified above, the maximum statutory period will apply and will expire SIX (6) MONTHS from the mailing date of this communication.
- Failure to reply within the set or extended period for reply will, by statute, cause the application to become ABANDONED (35 U.S.C. § 133). Any reply received by the Office later than three months after the mailing date of this communication, even if timely filed, may reduce any earned patent term adjustment. See 37 CFR 1.704(b).

**Status**

- 1)  Responsive to communication(s) filed on 15 August 2006.
- 2a)  This action is **FINAL**.                      2b)  This action is non-final.
- 3)  Since this application is in condition for allowance except for formal matters, prosecution as to the merits is closed in accordance with the practice under *Ex parte Quayle*, 1935 C.D. 11, 453 O.G. 213.

**Disposition of Claims**

- 4)  Claim(s) 1,4,6,7 and 10-53 is/are pending in the application.
- 4a) Of the above claim(s) \_\_\_\_\_ is/are withdrawn from consideration.
- 5)  Claim(s) \_\_\_\_\_ is/are allowed.
- 6)  Claim(s) 1,4,6,7 and 10-53 is/are rejected.
- 7)  Claim(s) \_\_\_\_\_ is/are objected to.
- 8)  Claim(s) \_\_\_\_\_ are subject to restriction and/or election requirement.

**Application Papers**

- 9)  The specification is objected to by the Examiner.
- 10)  The drawing(s) filed on 15 August 2006 is/are: a)  accepted or b)  objected to by the Examiner.  
    Applicant may not request that any objection to the drawing(s) be held in abeyance. See 37 CFR 1.85(a).  
    Replacement drawing sheet(s) including the correction is required if the drawing(s) is objected to. See 37 CFR 1.121(d).
- 11)  The oath or declaration is objected to by the Examiner. Note the attached Office Action or form PTO-152.

**Priority under 35 U.S.C. § 119**

- 12)  Acknowledgment is made of a claim for foreign priority under 35 U.S.C. § 119(a)-(d) or (f).
- a)  All    b)  Some \*    c)  None of:
1.  Certified copies of the priority documents have been received.
2.  Certified copies of the priority documents have been received in Application No. \_\_\_\_\_.
3.  Copies of the certified copies of the priority documents have been received in this National Stage application from the International Bureau (PCT Rule 17.2(a)).

\* See the attached detailed Office action for a list of the certified copies not received.

**Attachment(s)**

- |  |   |
|--|---|
| 1) <input checked="" type="checkbox"/> Notice of References Cited (PTO-892)                                | 4) <input type="checkbox"/> Interview Summary (PTO-413)<br>Paper No(s)/Mail Date. _____ |
| 2) <input type="checkbox"/> Notice of Draftsperson's Patent Drawing Review (PTO-948)                       | 5) <input type="checkbox"/> Notice of Informal Patent Application                       |
| 3) <input type="checkbox"/> Information Disclosure Statement(s) (PTO/SB/08)<br>Paper No(s)/Mail Date _____ | 6) <input type="checkbox"/> Other: _____  |

**DETAILED ACTION**

***Response to Affidavit***

The Declaration regarding the limited battery life under 37 CFR 1.132 filed 15 August 2006 is insufficient to overcome the rejection of the claims based upon the combination of Alstatt in view of Schotz as set forth in the last Office action.

As an initial matter, the data sheets in Exhibit A are generally unreadable as is all of Exhibit D. However, assuming that everything in Exhibit C that is taken from Exhibit's A and D are correct, the affidavit is still not persuasive.

The affidavit alleges that the combination of Alstatt in view of Schotz is non operative due to limited battery life. The affidavit is not persuasive for three reasons.

First, as stated in previous actions, one cannot accurately determine the time of operation because the power requirements are unknown. Applicant has done a sufficient job to show that the power requirements of Schotz are significantly greater than the power requirements of Alstatt in exhibits A, B and C. It is accepted by the examiner that the power requirements of Schotz are much greater than that of Alstatt. However, the affidavit fails to explicitly state or address where Alstatt discloses a 50 mA-h battery. The only section of Alstatt the affidavit refers to is col. 8 lines 22 – 24 which disclose that the battery has a voltage of 1.5V or 3.0V. Nothing is mentioned anywhere either in Alstatt or the affidavit where this battery of 50 mA-h is obtained. Thus the calculations cannot be considered persuasive.

Secondly, the calculations provided in Exhibit C prove that that combination is in fact operative. While the combination may be subject to limited battery life in the affidavit's calculations, it will still operate. The calculation's in Exhibit C show operation times of 6, 8, 11 and 15 minutes. Thus the combination cannot possibly be non-operative.

Lastly, it should be noted that it is unlikely that a 50 mA-h batter is used in the Alstatt device. Batteries for portable devices at the time of the Alstatt invention are known to have much greater chargers, as much as 1116 mA-h per gram (see Goldner U.S. 6,982,132). Examiner submits that it is more likely that the Alstatt device uses one of these larger batteries than the 50 mA-h battery stated by the affidavit. Even if this was not the case, it would be notoriously well known and obvious to use this larger battery, thus defeating the limited battery life allegation.

The Declaration regarding FSK being an inherent feature of FHSS and FHSS, and DSSS are inherent features of CDMA under 37 CFR 1.132 filed 15 August 2006 is insufficient to overcome the new matter rejections

The affidavit alleges that FSK is an inherent feature of FHSS and FHSS and DSSS is an inherent feature of CDMA. Inherency is defined in the MPEP § 2112 IV as follows:

The fact that a certain result or characteristic may occur or be present in the prior art is not sufficient to establish the inherency of that result or characteristic. *In re Rijckaert*, 9 F.3d 1531, 1534, 28 USPQ2d 1955, 1957 (Fed. Cir. 1993) (reversed rejection because inherency was based on what would result due to optimization of conditions, not what was necessarily present in the prior art); *In re Oelrich*, 666 F.2d 578, 581-82, 212 USPQ 323, 326 (CCPA 1981). "To establish inherency, the extrinsic evidence 'must make clear that the missing descriptive matter is necessarily present in the thing

Art Unit: 2615

described in the reference, and that it would be so recognized by persons of ordinary skill. Inherency, however, may not be established by probabilities or possibilities. The mere fact that a certain thing may result from a given set of circumstances is not sufficient.' ” *In re Robertson*, 169 F.3d 743, 745, 49 USPQ2d 1949, 1950-51 (Fed. Cir. 1999)

It is submitted that FHSS and DSSS may occur or be present in CDMA and thus not inherent. The CDMA overview provided by [www.telecomspace.com](http://www.telecomspace.com) discloses three ways to spread the bandwidth of a signal in CDMA, Frequency hopping, Time hopping and Direct Sequence. As such, FHSS and DSSS may be present but aren't necessarily required, thus they cannot be inherent. Neither of the three methods disclosed for spreading were present in either the parent specification or the instant application's specification. The addition of them will result in a new matter situation as they are not inherent.

Additionally, because they are not inherent, the inherency of FSK is moot. The affidavit alleges that FSK is inherent in FHSS and since it is shown that FHSS is not inherent in CDMA, FSK cannot be added to the instant application without creating a new matter situation.

### ***Response to Arguments***

Applicant's arguments filed 18 August 2006 have been fully considered but they are not persuasive.

Applicant alleges:

Art Unit: 2615

The rejections of Claims 1, 4; 6 and 10 under 35 U.S.C. §112, first paragraph, are respectfully traversed. Paragraphs [0014] and [0016] of the parent application disclose the features related to the generation of a unique codeword for an individual user. Pattern is defined as "an orderly sequence consisting of a number of repeated or Complimentary elements...." (New Lexicon Webster's Encyclopedic Dictionary of the English Language, Deluxe Edition 1991). The specification discloses how a unique codeword is generated that spreads the signal spectrum. Spreading or frequency hopping is used to control the sequence (i.e. pattern) of carrier frequency. Based on the above, a person skilled in the art at the time the invention was made would clearly conclude that the generation of a unique codeword for each individual user is the same as generation of a unique hop pattern for each individual user when applying frequency hopping spread spectrum. For the reasons set forth above, applicant-submits that claims 1, 4, 6 and 10 comply with the requirements set forth in 35 U.S.C. §112, first paragraph, and therefore, respectfully requests that the 35 USC. §112 rejections in regard to these claims be withdrawn.

Examiner disagrees. The specification is directed to a unique codeword for each individual user (paras. 0014 and 0016) as stated by Applicant. The unique codeword is never disclosed as a unique hop pattern nor is a unique hop pattern even disclosed. Applicant states : "Spreading or frequency hopping is used to control the sequence (i.e. pattern) of carrier frequency". Frequency hopping is not inherent in spreading. Thus while the codeword does spread the signal spectrum, the details of how it is done are never given in the specification. Spreading is done one of three ways in CDMA as shown above; none of the three ways are disclosed by Applicant. The addition of any of these, such as frequency hopping, is new matter.

### ***Specification***



The amendment filed 17 March 2006 is objected to under 35 U.S.C. 132(a) because it introduces new matter into the disclosure. 35 U.S.C. 132(a) states that no amendment shall introduce new matter into the disclosure of the invention. The added material which is not supported by the original disclosure is as follows:

1. "A frequency shift keying (FSK) modulation/detection technique could be used given a frequency hopping spread spectrum (FHSS) system choice."

The terms and techniques disclosed in this sentence (FSK and FHSS) were not present in the parent disclosure nor in the current application's disclosure and thus are new matter.

***Claim Rejections - 35 USC § 112***

The following is a quotation of the first paragraph of 35 U.S.C. 112:

The specification shall contain a written description of the invention, and of the manner and process of making and using it, in such full, clear, concise, and exact terms as to enable any person skilled in the art to which it pertains, or with which it is most nearly connected, to make and use the same and shall set forth the best mode contemplated by the inventor of carrying out his invention.

**Claims 1, 4, 6, 10, 12 and 13** are rejected under 35 U.S.C. 112, first paragraph, as failing to comply with the written description requirement. The claim(s) contains subject matter which was not described in the specification in such a way as to reasonably convey to one skilled in the relevant art that the inventor(s), at the time the application was filed, had possession of the claimed invention. The newly added limitation of "a unique hop pattern for each individual user" is not supported in the

Art Unit: 2615

disclosure of neither the present application nor the parent application. The relied upon disclosures teach generating a unique user code with one user but do not disclose any details on creating a unique "hop pattern" for each individual user.

**Claims 19 – 32, 43 – 53** are rejected under 35 U.S.C. 112, first paragraph, as failing to comply with the written description requirement. The claim(s) contains subject matter which was not described in the specification in such a way as to reasonably convey to one skilled in the relevant art that the inventor(s), at the time the application was filed, had possession of the claimed invention. Claims 19 – 32, 43 – 53 contain limitations directed to DSSS which is not in the original specification nor inherent as alleged by applicant.

The following is a quotation of the second paragraph of 35 U.S.C. 112:

The specification shall conclude with one or more claims particularly pointing out and distinctly claiming the subject matter which the applicant regards as his invention.

**Claims 14 and 15** are rejected under 35 U.S.C. 112, second paragraph, as being indefinite for failing to particularly point out and distinctly claim the subject matter which applicant regards as the invention.

Claims 14 and 15 recite the limitation "said processed CDMA signal." There is insufficient antecedent basis for this limitation in the claim.

***Claim Rejections - 35 USC § 102***

The following is a quotation of the appropriate paragraphs of 35 U.S.C. 102 that form the basis for the rejections under this section made in this Office action:

A person shall be entitled to a patent unless –

(e) the invention was described in (1) an application for patent, published under section 122(b), by another filed in the United States before the invention by the applicant for patent or (2) a patent granted on an application for patent by another filed in the United States before the invention by the applicant for patent, except that an international application filed under the treaty defined in section 351(a) shall have the effects for purposes of this subsection of an application filed in the United States only if the international application designated the United States and was published under Article 21(2) of such treaty in the English language.

**Claims 33 and 34** are rejected under 35 U.S.C. 102(e) as being anticipated by Lindemann (U.S. Patent Application 2004/0223622).

Regarding **Claim 33**, Lindemann discloses:

A wireless digital audio system (Fig. 15B and Fig 17), comprising:

at least one audio source (Fig. 15B, 133, 134, 135);

at least one digital audio transmitter operatively coupled to said at least one audio source (Fig. 15B 131);

at least one audio receiver adapted for digital wireless communication with said at least one audio transmitter (Fig. 15B, 130 and Fig. 17 300)

each of said at least one digital audio transmitter and receiver being configured for code division multiple access (CDMA) communication (para 0075); and

at least one module adapted to audibly reproduce said processed CDMA signal, said CDMA communication configuration providing a user with independent audio reproduction free of interference from other users or wireless devices (Fig. 15A).

Regarding **Claim 34**, in addition to the elements stated in the rejection of claim 33, Lindemann further discloses:

At least one module adapted to amplify said processed CDMA signals (Fig. 17 element 301).

***Claim Rejections - 35 USC § 103***

The following is a quotation of 35 U.S.C. 103(a) which forms the basis for all obviousness rejections set forth in this Office action:

(a) A patent may not be obtained though the invention is not identically disclosed or described as set forth in section 102 of this title, if the differences between the subject matter sought to be patented and the prior art are such that the subject matter as a whole would have been obvious at the time the invention was made to a person having ordinary skill in the art to which said subject matter pertains. Patentability shall not be negated by the manner in which the invention was made.

**Claims 1, 4, 6, 7, 10 – 13** are rejected under 35 U.S.C. 103(a) as being unpatentable over Alstatt (U.S. Patent 5,771,441) in view of Schotz (U.S. Patent 5,946,343) and in further view of Schotz (U.S. Patent 5,491,839) and in further view of Rozin (U.S. Patent 6,342,844)

Regarding **Claim 1**,

Alstatt teaches an audio dongle for an utilizes a RF connection to interface portable audio device a pair of wireless headphones.

Specifically regarding Claim Alstatt teaches:

A wireless audio music system (Figure 1) for communication of an audio music signal (from 10) from the analog headphone jack (12) connected to a battery powered transmitter (14) and received by a battery powered headphone receiver (col. 4 lines 29-53; battery transmitter 43 col. 6, line 54; battery for headphone receiver is implicit the wireless nature of the headphones and context Alstatt) comprising:

an analog headphone jack (12) from an audio music source (10) in communication with a batter powered digital transmitter (14) (col. 4 lines 29 – 39)

The headphone system of Altstatt includes an antenna (24), receiver (22) and earphones 26 and 28.

However, the system of Altstatt an analog transmission system that, operation, lacks the benefits digitally encoded and transmitted audio signal.

With regard to the limitations of Claim 1, Altstatt does not clearly teach or suggest:

A wireless digital audio music system for spread spectrum communication  
said battery powered digital transmitter converts an analog audio music signal from said existing analog headphone jack to a digital signal using an ADC in communication with an encoder

said encoder in communication with a channel encoder

said digital modulator in communication with a spread spectrum communication modulator that utilizes a code generator to create a unique hop pattern for each individual user;

said spread spectrum communication modulator in communication with a transmit antenna that transmits a radio frequency of approximately 2.4 GHz for receipt by a receiving antenna;

said receiving antenna in communication with a spread spectrum communication demodulator

said spread spectrum communication demodulator in communication with a receiver code generator and with a digital demodulator;

said digital demodulator in communication with a wide bandpass filter

said wide bandpass filter in communication with a channel decoder;

said channel decoder in communication with a receiver decoder;

said DAC in communication with a filter to pass the analog music signal in the approximate frequency band of 20Hz to 20 kHz; and

said filter passing analog music signal will be amplified for processing to a speaker headphone set to provide high quality music for listening by a signal user wearing the headphones.

Schotz et al discloses a wireless digital audio transmission system.

Specifically regarding Claim 1, Schotz et al, when considered in view of the teachings of Altstatt applied above, teaches or at least suggests:

A wireless digital audio music system for spread spectrum communication  
(Figure 1 of Schott et al in view of Figure 1 of Altstatt, col. 6, lines 6-54; col. 14, lines 5-12)

said digital transmitter (22 of Schotz et al in view of 14 of Altstatt) converts an analog audio music signal from said existing analog headphone jack (analog input 30A,30B of Schott et al in view of analog connection 12,18 of Altstatt) to a digital signal using an ADC (52) in communication with an encoder (300) (col. 7, lines 6-15; col. 14, lines 43-58, as noted above 'in communication' has been interpreted herein to mean passing a signal between the two components, regardless of other components that may be disposed between two said components)

said encoder (300) in communication with a channel encoder (98) (col. 9, lines 1-48; col. 14, lines 61-65)

said digital modulator (102) in communication with a spread spectrum communication modulator (104) that utilizes a code generator (106,308) (102 modulates input signal to produce I,Q signals, col. 10, lines 17-24; spread spectrum, col. 14, lines 5-12, col. 15, lines 40-52; code generator and user code corresponds to either house select code or PN code, col. 10, lines 43-47 or col. 15, lines 40-52; either can be considered to generate 'user codes' in context of Schotz et al and particularly Altstatt in that the use of a transmitter corresponds to a particular user operating said transmitter);

said spread spectrum communication modulator (104) in communication (via 108) with a transmit antenna (38) that transmits at a radio frequency of approximately 2.4 GHz for receipt by a receiving antenna (40) (col. 6, lines 39-42; col. 10, lines 31-37)

said receiving antenna (40) in communication with a spread spectrum communication demodulator (comprising 144,146,148; col. 11, line 13 - col. 12, line 24; col. 15, lines 45-52)

said spread spectrum communication demodulator (144,146,148) in communication with a receiver code generator (408 or house code generator, col. 11, lines 13-56; col. 15, lines 45-52) and with a digital demodulator (202)(202 reverses phase shift modulation and combines signals, col. 12, lines 41-47);

said digital demodulator (202) in communication with a wide bandpass filter (such as 138 or 142 or 178, via components of 140,146) (col. 11, lines 14-24, col. 12, lines 1-11, noting that audio signals require wideband transmission col. 2, lines 58-60, which infers such a wideband nature on these filters);

said wide bandpass filter (such as 138 or 142 or 178) in communication (via components of 140,146) with a channel decoder (198) (col. 12, lines 1-28);

said channel decoder (198) in communication with a receiver decoder (400)(col. 15, lines 10-18);

said receiver decoder (400)in communication with a DAC (216) (col. 15, lines 10-26);

said DAC (216) in communication with a filter (218A,2185) to pass the analog music signal in the approximate frequency band of 20Hz to 20 kHz (signal is music, col. 2, lines 55-58; filtering col. 13, lines 57-67)

To one of ordinary skill in the art at the time the invention was made, it would have been obvious to modify the wireless audio system of Altstatt to incorporate the



Art Unit: 2615

digital transmission and reception scheme of Schotz et al for the wireless communication of full range audio data. The motivation behind such a modification would have been that such a digital transmission would have provided a number of benefits, including the reception of CD-quality sound and forwarding error correction, the latter of which would have enabled the system to account for errors in transmission. The digital-based system of Schotz et al would have also enabled the option of muting the output signal in the presence of sufficient levels of error. The spread spectrum technique of Schotz et al would have also limited interference from another signal to cause error in only one portion of the transmitted signal rather than the entire signal. Further, the transmission components of Schotz et al would have also permitted transmission over unlicensed frequency bands.

while the system of Altstatt in view of Schotz et al discloses a variety of filtering and other signal modifications, Altstatt in view of Schotz et al is not considered to clearly teach or suggest:

said channel encoder in communication with a digital low pass filter

said digital low pass filter in communication with a digital modulator

said DAC in communication with a filter that is a low pass filter

said filter passing analog music signal will be amplified for processing to a speaker headphone set to provide high quality music for listening by a single user wearing the headphones

However, Schotz et al incorporates another digital wireless system by reference, issued to Schotz.

Specifically regarding the limitations of Claim 1, Schotz, in view of the teachings of Altstatt and Schotz et al as applied above, teaches or at least suggests:

said channel encoder (300 of Schotz et al) in communication with a digital low pass filter (60 of Schotz)(col. 6, lines 41-53 of Schotz for lowpass filtering buffer 60, in view of modification listed below)

said digital low pass filter (60) in communication with a digital modulator (102 of Schotz et al)(col. 6, lines 41-53 of Schotz for lowpass filtering buffer 60, in view of modification listed below)

said DAC (216 of Schotz et al, which provides output signal) in communication with a filter that is a low pass filter (152 of Schotz in view of 218A, B of Schotz et al)

said filter (152) passing analog music signal will be amplified (by 156) for processing to a speaker headphone set (Figure 1 of Schotz, in view of headphones of Altstatt) to provide high quality music for listening by a single user wearing the headphones (col. 4, lines 2-5; col. 10, lines 19-22, noting that signal expansion is one form of amplitude control; it is further noted that otherwise output amplifying an audio signal for application to speakers is substantially well-known in the art).

To one of ordinary skill in the art at the time the invention was made, it would have been obvious to incorporate the low-pass filtering buffer of Schotz as part of the circuitry processing the output signal of the ADC (that is, as part of the signal path following the ADC) in the transmitter of Altstatt in view of Schatz et al. The motivation behind such a modification would have been that such a filtering buffer would have removed high frequency harmonics resulting from the multiplexing of the signal in the

ADC. To one of ordinary skill in the art at the time the invention was made, it would have been obvious to incorporate low pass filtering as taught by Schotz for the output filters of Altstatt in view of Schotz et al. The motivation behind such a modification would have been that such low pass filtering would have enabled the removal of any pilot or multiplexing byproducts yet present in the output signal. To one of ordinary skill in the art at the time the invention was made, it would have been obvious to incorporate the compression and expansion circuitry of Schotz as part of the input and output handling circuitry of the system of Altstatt in view of Schotz et al. The motivation behind such a modification would have been that such a form of signal amplitude control would have placed the throughput audio signals within the linear operating ranges of the audio channels in the transmitter and receiver.

Additionally, the combination shown above fails to explicitly disclose that the code generator creates a unique hop pattern for each individual user. As shown above, the Schotz reference in the combination discloses a code generator (106,308).

While it is not taught to use a unique hop pattern for each individual user, doing so in a FHSS implementation (which is suggested by Schotz; col. 14 lines 5 – 12) is notoriously well known in the art.

Rozin discloses a code generator that creates a unique hop pattern for each individual user (col. 9 lines 52 – 67 and col. 10 lines 1 – 27).

While Rozin is not directed to the digital audio art, since FHSS is used, the data that is coded is irrelevant. It would have been obvious to one of ordinary skill in the art to apply Rozin's teachings to the combination disclosed above. One would have been

Art Unit: 2615

motivated to do so to avoid interference, collisions, and interceptions (col. 10 lines 13 – 17 of Rozin) between the various devices in the household disclosed by Schotz.

Regarding **Claim 4**, please refer above to the functions-corresponding to the components cited above in the rejection of the similar limitations of Claim 1. The citations provided therein form the basis for the rejection of the similar limitations of the method steps of Claim 4. In addition, the claimed power level and distance of approximately 10 ft is at least considered suggested by Schott et al's reference to a range within 10 ft (col. 5, lines 26-36).

Regarding **Claim 6**, please refer above to the components cited above in the rejection of the similar limitations of Claim 1, particularly the first portion of Claim 1. The citations provided therein form the basis for the rejection of the similar limitations of the apparatus of Claim 6.

Regarding **Claim 7**, please refer above to the components cited above in the rejection of the similar limitations of Claim 1, particularly the first portion of Claim 1. The citations provided therein form the basis for the rejection of the similar limitations of the apparatus of Claim 7.

Regarding **Claim 10**, please refer above to the components cited above in the rejection of the similar limitations of Claim 1. The citations provided therein form the basis for the rejection of the similar limitations of the apparatus of Claim 9.

However, the combination in claim 1 does not disclose that the channel encoder is configured to send encoded symbols that are compatible with a Viterbi decoder or that the decoder is a Viterbi decoder.

The Examiner takes Official notice that soft decision Viterbi decoders are notoriously well known in the art (See wikipedia.com entries for Viterbi decoder and Viterbi Algorithm). Applying the Viterbi decoding method disclosed in these entries would read upon the limitations of the channel encoder is configured to send encoded symbols that are compatible with a Viterbi decoder or that the decoder is a Viterbi decoder.

It would have been obvious to one of ordinary skill in the art at the time of the invention to modify the combination's decoder to perform as a soft-decision Viterbi decoder. Viterbi decoders are often used in telecommunication lines and for amateur radio and radio relay (see wikipedia Viterbi entries). It would be an advantage to use the Viterbi decoder in the combination's circuitry because Viterbi decoding has an advantage of a fixed decoding time making it well suited for hardware decoder implementation (Flemming).

Art Unit: 2615

Regarding **Claim 11**, please refer above to the components cited above in the rejection of the similar limitations of Claim 9. The citations provided therein form the basis for the rejection of the similar limitations of the apparatus of Claim 11.

Regarding **Claim 12**, please refer above to the components cited above in the rejection of the similar limitations of Claim 1. The citations provided therein form the basis for the rejection of the similar limitations of the apparatus of Claim 12.

In addition, the combination further discloses a 2.4 GHz direct conversion receiver that includes a spread spectrum communication demodulator and a receiver code generator (Schotz elements 40, 106,308, 144,146,148; col. 11, line 13 - col. 12, line 24; col. 15, lines 45-52).

Regarding **Claim 13**, please refer above to the components cited above in the rejection of the similar limitations of Claim 7. The citations provided therein form the basis for the rejection of the similar limitations of the apparatus of Claim 13.

In addition, the combination further discloses a 2.4 GHz direct conversion receiver that includes a spread spectrum communication demodulator and a receiver code generator (Schotz elements 40, 106,308, 144,146,148; col. 11, line 13 - col. 12, line 24; col. 15, lines 45-52).

**Claims 14 – 16, 39 and 40** are rejected under 35 U.S.C. 103(a) as being unpatentable over Lindemann (U.S. Patent Application Publication 2004/0223622) in view of Benthin (U.S. Patent 5,790,595)

Regarding **Claim 14**, Lindemann discloses:

A wireless digital audio system (Fig. 15B and Fig 17), comprising:

at least one audio source (Fig. 15B, 133, 134, 135);

at least one digital audio transmitter operatively coupled to said at least one audio source (Fig. 15B 131);

at least one audio receiver adapted for digital wireless communication with said at least one audio transmitter (Fig. 15B, 130 and Fig. 17 300)

each of said at least one digital audio transmitter and receiver being configured for code division multiple access (CDMA) communication (para 0075); and

at least one module adapted to audibly reproduce said processed CDMA signal, said CDMA communication configuration providing a user with independent audio reproduction free of interference from other users or wireless devices (Fig. 15A).

Lindemann does not explicitly disclose that the transmitter is utilizing fuzzy logic to optimize digital signal processing.

Lindemann in view of Benthin discloses

a transmitter (i.e. the transmitter of Lindemann) utilizing fuzzy logic to optimize digital signal processing (Benthin col. 2 lines 6 – 31 and col. 5 lines 10 – 25).

To one of ordinary skill in the art at the time the invention was made, it would have been obvious to implement the convolutional encoding scheme as well as the soft decision relevant components of Benethin as part of the encoding and signal reception parts of the system Lindemann. The motivation behind such a modification would have been that convolutional encoding is well known in the art to perform well under high error conditions and is often inexpensive to implement. The soft bit determining circuitry would have improved the reliability of the decision relating to the hard data bit equivalents of the received information, as is taught by Benethin.

Regarding **Claim 15**, in addition to the rejection of claim 14, the combination further discloses:

at least one module adapted to amplify said processed CDMA signal (Fig. 17 element 301).

Regarding **Claim 16**, in addition to the rejection of claim 15, the combination further discloses:

wherein said at least one signal amplifying module includes at least one power amplifier, said at least one power amplifier being configured to provide a low distortion audio signal output (i.e. the amplifier 301 is a low noise amplifier).

Regarding **Claims 39 and 40**, in addition to the elements stated above regarding claims 33 and 34, the combination does not disclose wherein at least one of said digital



Art Unit: 2615

audio transmitter and receiver is battery powered. However, it would have been obvious to one of ordinary skill in the art at the time of the invention to make the speaker reception portion of the combination's battery powered. One would have been motivated to do so to be able to place and use the speakers in an area where standard power supplies are unavailable (i.e. outdoors).

**Claims 17 and 18** are rejected under 35 U.S.C. 103(a) as being unpatentable over Alstatt (U.S. Patent 5,771,441) in view of Lindemann (U.S. Patent Application Publication 2004/0223622) and in further view of Benthin (U.S. Patent 5,790,595).

Regarding **Claims 17 and 18**, Alstatt teaches:

An audible reproducing module including at least one headphone speaker (Fig.1).

Alstatt does not disclose the limitations of claims 14, 15 or 16. The combination of Lindemann in view of Benthin as shown above in the rejections of claim 15 and 16 meet these limitations.

To one of ordinary skill in the art at the time the invention was made, it would have been obvious to modify the wireless audio system of Alstatt to incorporate the digital transmission and reception scheme of Lindemann in view of Benthin for the wireless communication of full range audio data. The motivation behind such a

modification would have been that such a digital transmission would have provided a number of benefits, including the reception of CD-quality sound and forwarding error correction, the latter of which would have enabled the system to account for errors in transmission. The digital-based system of the combination would have also enabled the option of muting the output signal in the presence of sufficient levels of error. The spread spectrum technique of the combination would have also limited interference from another signal to cause error in only one portion of the transmitted signal rather than the entire signal. Further, the transmission components of the combination would have also permitted transmission over unlicensed frequency bands.'

Additionally the combination discloses:

Said at least one headphone speaker (i.e. Fig. 1 of Alstatt) receiving said low distortion audio signal output from said at least one power amplifier (i.e. the headphone of Alstatt receiving the audio which has been amplified by 301 in place of the speaker in 15A of Lindemann).

**Claims 35 and 36** are rejected under 35 U.S.C. 103(a) as being unpatentable over Lindemann (U.S. Patent Application Publication 2004/0223622) in view of view of Benthin (U.S. Patent 5,790,595) and in further view of Schotz (U.S. Patent 5,946,343).

Regarding **Claims 35 and 36**, in addition to the elements stated above regarding claims 14 and 15, the combination does not explicitly disclose wherein said at least one audio source provides analog output in the approximate range of 20 Hz to 20 kHz.

Schotz discloses one audio source provides analog output in the approximate range of 20 Hz to 20 kHz (Fig. 1 element 26).

It would have been obvious to one of ordinary skill in the art at the time of the invention to modify the combination to include the analog sources such as the AM/FM tuner of Schotz. One would have been motivated to do so to allow users of the combination to enjoy a commonly available and widespread audio format such as AM/FM.

**Claims 37 and 38** are rejected under 35 U.S.C. 103(a) as being unpatentable over Lindemann (U.S. Patent Application Publication 2004/0223622) in view of Schotz (U.S. Patent 5,946,343).

Regarding **Claims 37 and 38**, in addition to the elements stated above regarding claims 16 and 17, Lindemann does not explicitly disclose wherein said at least one audio source provides analog output in the approximate range of 20 Hz to 20 kHz.

Schotz discloses one audio source provides analog output in the approximate range of 20 Hz to 20 kHz (Fig. 1 element 26).

It would have been obvious to one of ordinary skill in the art at the time of the invention to modify Lindemann to include the analog sources such as the AM/FM tuner of Schotz. One would have been motivated to do so to allow users of Lindemann to enjoy a commonly available and widespread audio format such as AM/FM.

**Claims 41 and 42** are rejected under 35 U.S.C. 103(a) as being unpatentable over Lindemann (U.S. Patent Application Publication 2004/0223622).

Regarding **Claims 41 and 42**, in addition to the elements stated above regarding claims 33 and 34, Lindemann does not disclose wherein at least one of said digital audio transmitter and receiver is battery powered. However, it would have been obvious to one of ordinary skill in the art at the time of the invention to make the speaker reception portion of Lindemann battery powered. One would have been motivated to do so to be able to place and use the speakers in an area where standard power supplies are unavailable (i.e. outdoors).

### ***Conclusion***

**THIS ACTION IS MADE FINAL.** Applicant is reminded of the extension of time policy as set forth in 37 CFR 1.136(a).

A shortened statutory period for reply to this final action is set to expire **THREE MONTHS** from the mailing date of this action. In the event a first reply is filed within **TWO MONTHS** of the mailing date of this final action and the advisory action is not mailed until after the end of the **THREE-MONTH** shortened statutory period, then the shortened statutory period will expire on the date the advisory action is mailed, and any extension fee pursuant to 37 CFR 1.136(a) will be calculated from the mailing date of

the advisory action. In no event, however, will the statutory period for reply expire later than SIX MONTHS from the mailing date of this final action.

Any inquiry concerning this communication or earlier communications from the examiner should be directed to Andrew C. Flanders whose telephone number is (571) 272-7516. The examiner can normally be reached on M-F 8:30 - 5:00.

If attempts to reach the examiner by telephone are unsuccessful, the examiner's supervisor, Sinh Tran can be reached on (571) 272-7546. The fax phone number for the organization where this application or proceeding is assigned is 571-273-8300.

Information regarding the status of an application may be obtained from the Patent Application Information Retrieval (PAIR) system. Status information for published applications may be obtained from either Private PAIR or Public PAIR. Status information for unpublished applications is available through Private PAIR only. For more information about the PAIR system, see <http://pair-direct.uspto.gov>. Should you have questions on access to the Private PAIR system, contact the Electronic Business Center (EBC) at 866-217-9197 (toll-free). If you would like assistance from a USPTO Customer Service Representative or access to the automated information system, call 800-786-9199 (IN USA OR CANADA) or 571-272-1000.

acf

  
**SINH TRAN**  
SUPERVISORY PATENT EXAMINER

**Notice of References Cited**

Application/Control No. 10/648,012	Applicant(s)/Patent Under Reexamination WOOLFORK, C. EARL	
Examiner Andrew C. Flanders	Art Unit 2615	Page 1 of 1

**U.S. PATENT DOCUMENTS**

*		Document Number Country Code-Number-Kind Code	Date MM-YYYY	Name	Classification
*	A	US-6,982,132	01-2006	Goldner et al.	429/162
*	B	US-2004/0223622	11-2004	Lindemann et al.	381/079
	C	US-			
	D	US-			
	E	US-			
	F	US-			
	G	US-			
	H	US-			
	I	US-			
	J	US-			
	K	US-			
	L	US-			
	M	US-			

**FOREIGN PATENT DOCUMENTS**

*		Document Number Country Code-Number-Kind Code	Date MM-YYYY	Country	Name	Classification
	N					
	O					
	P					
	Q					
	R					
	S					
	T					

**NON-PATENT DOCUMENTS**

*		Include as applicable: Author, Title Date, Publisher, Edition or Volume, Pertinent Pages)
	U	www.telecomspace.com overview for CDMA
	V	
	W	
	X	

\*A copy of this reference is not being furnished with this Office action. (See MPEP § 707.05(a).)  
 Dates in MM-YYYY format are publication dates. Classifications may be US or foreign.



Application/Control No.	Applicant(s)/Patent under Reexamination	
10/648,012	WOOLFORK, C. EARL	
Examiner	Art Unit	
Andrew <del>Chen</del> <i>Floods</i>	2644	

SEARCHED			
Class	Subclass	Date	Examiner
700	94	5/10/2005	AG <i>Def</i>
714	709,780	5/10/2005	AG
706	8,9	5/10/2005	AG
455	3,06,41	5/10/2005	AG
455	66.1	5/10/2005	AG
375	224	5/10/2005	AG
381	79	12/15/2005	<del>AG</del>
455	41.3	12/15/2005	<del>AG</del>
	<i>updated</i>	<i>9/25/05</i>	<i>ACF</i>
<i>455</i>	<i>564,1,412</i>	<i>7/25/05</i>	<i>ACF</i>
<i>455</i>	<i>913</i>	<i>9/25/05</i>	<i>ACF</i>
<i>375</i>	<i>245-277</i>	<i>9/25/05</i>	<i>ACF</i>
<i>375</i>	<i>346,348</i>	<i>9/25/05</i>	<i>ACF</i>
<i>375</i>	<i>219</i>	<i>9/25/05</i>	<i>ACF</i>

INTERFERENCE SEARCHED			
Class	Subclass	Date	Examiner

SEARCH NOTES (INCLUDING SEARCH STRATEGY)		
	DATE	EXMR
EAST search using USPAT PGPUB DERWENT EPO JPO USOCR dbs	5/10/2005	AG
cls/sbcls at left w/ keywords Bluetooth, fuzzy, soft decision, bit energy, probability, membership, and equivalents	5/10/2005	AG
Parent application, including applied references, considered	5/10/2005	AG
Inventor search, using EAST and internet search engine	5/10/2005	AG
381/2,455/41.2,41.3 (l.o.w/low pass) 381/270 (l.o.w/ headphone) various text search - see search history printout	12/15/2005	<del>AG</del>
<i>Reviewed + updated</i>	<i>5/21/05</i>	<i>ACF</i>
<i>Part of EAST lost</i>	<i>9/25/05</i>	<i>ACF</i>
<i>Tse Young</i>	<i>9/22/05</i>	<i>ACF</i>
<i>Bill Frost</i>	<i>9/25/05</i>	<i>ACF</i>
<i>Lewis West</i>	<i>9/25/05</i>	<i>ACF</i>
<i>Quochien Yung</i>	<i>9/22/05</i>	<i>ACF</i>

**Index of Claims**



Application/Control No.

10/648,012

Examiner *Fladers*  
Andrew ~~Ortega~~

Applicant(s)/Patent under Reexamination

WOOLFORK, C. EARL

Art Unit

2644

✓	Rejected
=	Allowed

-	(Through numeral) Canceled
+	Restricted

N	Non-Elected
I	Interference

A	Appeal
O	Objected

Claim		Date	
Final	Original		
	1	✓	5/10/05
	2	✓	12/22/05
	3	✓	5/3/06
	4	✓	7/28/06
	5	✓	
	6	✓	
	7	✓	
	8	✓	
	9	✓	
	10	✓	
	11	✓	
	12	✓	
	13	✓	
	14	✓	
	15	✓	
	16	✓	
	17	✓	
	18	✓	
	19	✓	
	20	✓	
	21	✓	
	22	✓	
	23	✓	
	24	✓	
	25	✓	
	26	✓	
	27	✓	
	28	✓	
	29	✓	
	30	✓	
	31	✓	
	32	✓	
	33	✓	
	34	✓	
	35	✓	
	36	✓	
	37	✓	
	38	✓	
	39	✓	
	40	✓	
	41	✓	
	42	✓	
	43	✓	
	44	✓	
	45	✓	
	46	✓	
	47	✓	
	48	✓	
	49	✓	
	50	✓	

Claim		Date	
Final	Original		
	51		
	52		
	53		
	54		
	55		
	56		
	57		
	58		
	59		
	60		
	61		
	62		
	63		
	64		
	65		
	66		
	67		
	68		
	69		
	70		
	71		
	72		
	73		
	74		
	75		
	76		
	77		
	78		
	79		
	80		
	81		
	82		
	83		
	84		
	85		
	86		
	87		
	88		
	89		
	90		
	91		
	92		
	93		
	94		
	95		
	96		
	97		
	98		
	99		
	100		

Claim		Date	
Final	Original		
	101		
	102		
	103		
	104		
	105		
	106		
	107		
	108		
	109		
	110		
	111		
	112		
	113		
	114		
	115		
	116		
	117		
	118		
	119		
	120		
	121		
	122		
	123		
	124		
	125		
	126		
	127		
	128		
	129		
	130		
	131		
	132		
	133		
	134		
	135		
	136		
	137		
	138		
	139		
	140		
	141		
	142		
	143		
	144		
	145		
	146		
	147		
	148		
	149		
	150		