

[54] METHOD OF TRANSDERMAL DRUG DELIVERY

[75] Inventor: Elie S. Nuwayser, Wellesley, Mass.

[73] Assignee: Biotek, Inc., Woburn, Mass.

[21] Appl. No.: 653,362

[22] Filed: Oct. 1, 1984

[51] Int. Cl.⁴ A61F 13/02; A01N 25/26; A61J 3/00; A61K 9/70

[52] U.S. Cl. 604/307; 424/16; 424/28; 424/78

[58] Field of Search 424/16, 28, 78; 604/307

[56] References Cited

U.S. PATENT DOCUMENTS

| | | | |
|-----------|---------|--------------|---------|
| 3,797,494 | 3/1974 | Zaffaroni | 604/897 |
| 4,053,580 | 10/1977 | Chien et al. | 424/15 |
| 4,336,243 | 6/1982 | Sanvordeker | 424/28 |
| 4,466,953 | 8/1984 | Keith et al. | 424/28 |

OTHER PUBLICATIONS

"Topical Nitroglycerin", by J. F. Dasta et al., American Pharmacy, 22(2), 1982, pp. 29-35.

Primary Examiner—John E. Kittle
Assistant Examiner—Mukund J. Shah

Attorney, Agent, or Firm—Richard P. Crowley

[57] ABSTRACT

A transdermal drug delivery system useful for the controlled, for example zero order, release of one or more drugs to a selected skin area of a user, which system comprises an impervious backing sheet and a face membrane, the backing sheet and membrane secured together to form an intermediate reservoir. The face membrane is a macroporous membrane which has pores of sufficient size to avoid any rate control of the drug to be transdermally delivered to the user. The reservoir contains a viscous liquid base material selected to exude from the membrane to form a film and to occlude the skin of the user to force hydration of the stratum corneum with water from the lower layers of the epidermis of the user and a plurality of solid microparticles generally uniformly dispersed and suspended in the liquid base material. The microparticles containing an effective therapeutic amount of the drug for transdermal delivery, such as the contraceptive steroid. In use the liquid base material exuded from the macroporous membrane face forms a thermodynamically stable thin film layer in an intimate contact with the skin, while the drug is released from the microparticles into the base material and transdermally into the user.

14 Claims, 3 Drawing Figures

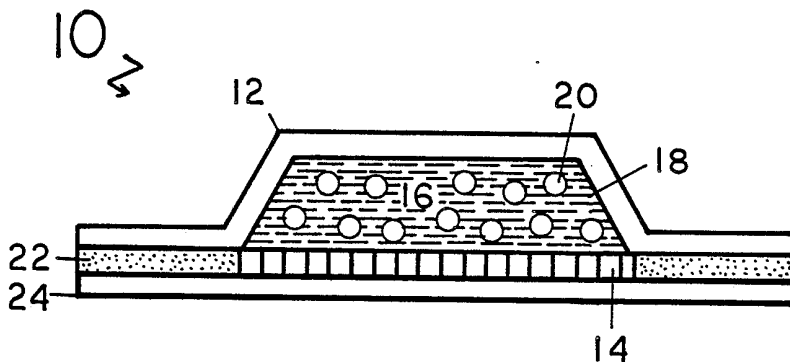

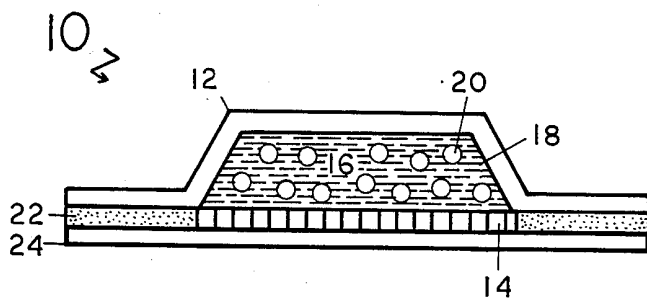

FIG. 1

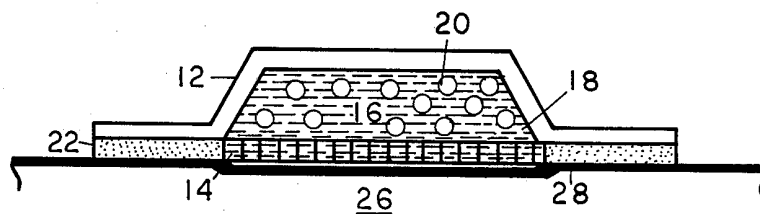
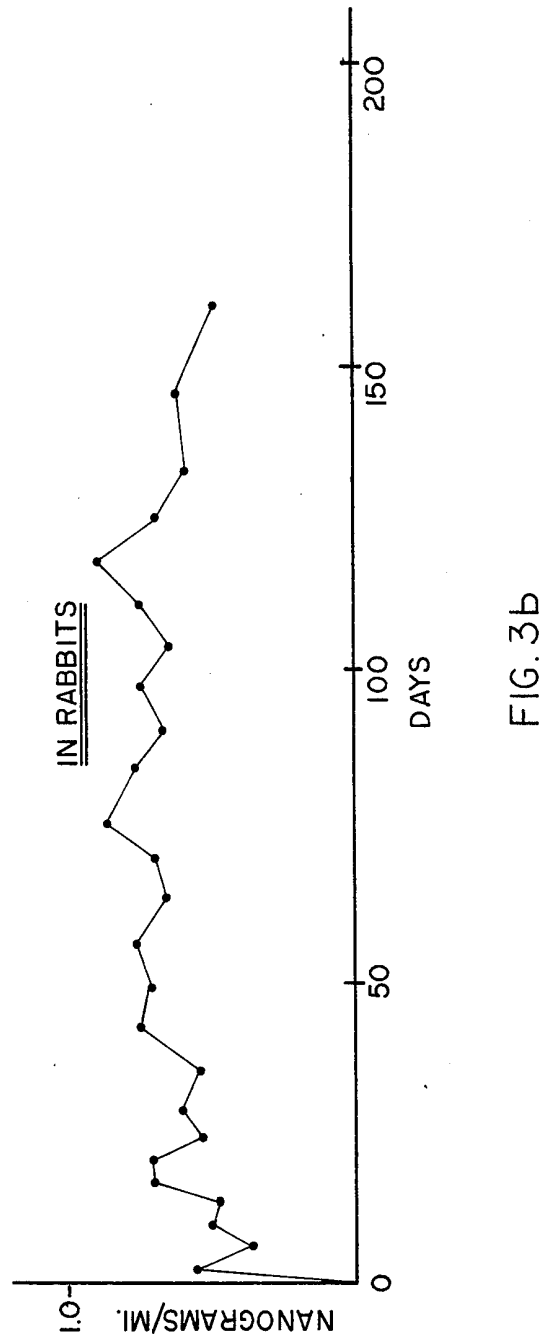
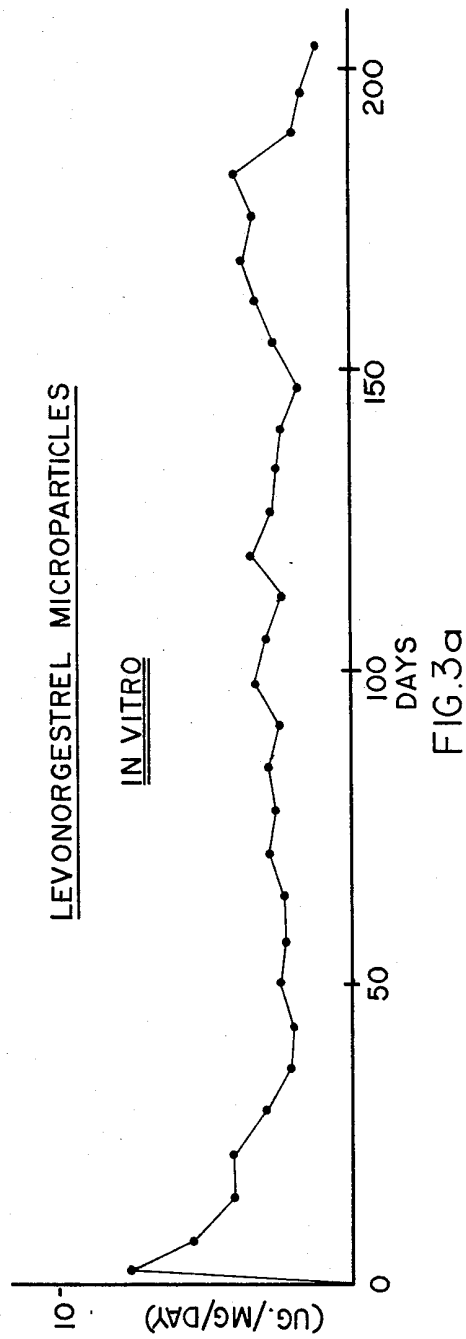

FIG. 2



METHOD OF TRANSDERMAL DRUG DELIVERY

REFERENCE TO PRIOR APPLICATIONS

This application discloses to a prior co-pending application U.S. Ser. No. 577,079, filed Feb. 6, 1984, entitled **COMPOSITE CORE COATED MICROPARTICLES AND PROCESS OF PREPARING SAME**. The prior application relates to a process for preparing coated solid microparticles and to the microparticles so prepared and to the use of the microparticles to provide for the sustained release of a drug incorporated in the microparticles. The process comprises preparing a solvent solution of an active ingredient such as a drug to be encapsulated, but more particularly a contraceptive steroid-type drug and a film-forming polymer and removing the solvent to provide a dry, composite, uniform admixture of the drug-active ingredient and the polymer material. The mixture is then reduced to a defined, smaller particle size distribution and the ground admixture then coated in a fluidized bed with a uniform, defined wall thickness of the same or substantially the same film-forming polymer material used to provide the composite core coated microparticles. Typically, the dry composite admixture is reduced to a particle size of less than 1000 microns, e.g. 200 microns. The film forming polymer material employed generally is a polymer, like polyvinyl alcohol or a cellulosic material or a biodegradable polymer, such as for example, a polylactide, a polyglycolide, and copolymers of lactides and glycolides. The drug employed in the microparticles may vary, but typically may comprise for example, a contraceptive steroid-type drug such as levonorgestrel or estradiol. For injectable compositions the particle size of the microparticles is less than 200 microns with a uniform wall coating of about 0.2 to 20 microns. The microparticles are useful for the controlled release of a drug-active ingredient such as in a zero order release pattern and for example, may be employed by injecting microparticles suspended in a liquid carrier into a patient.

BACKGROUND OF THE INVENTION

Transdermal delivery of medication is not a new concept, as a variety of medications that are readily available for delivery through the skin have been available in ointment form for over thirty years. With ointments, however, it is difficult to achieve precise drug dosage. In a transdermal patch system, this problem is eliminated by controlling the rate of drug release over a prescribed period of time. Patches are worn behind the ear, on the chest, or on the arm and dispense a drug for as long as a week at a time. For certain drugs transdermal delivery has significant advantages over oral administration. It eliminates "first pass" inactivation by the liver and irregular gastric absorption. Because of constant absorption through the skin, it maintains relatively constant blood levels of the drug.

Two drugs, scopolamine and nitroglycerin, have recently become commercially available in transdermal form. Although there are differences in composition and in the mechanism of drug delivery among the available transdermal delivery systems, they all appear to be functionally similar. Generally the systems have essentially steady state reservoirs sandwiched between an impervious backing and a membrane face. The systems usually are attached to the skin by an adhesive gel. Some products have a rate-controlling outer micropo-

rous membrane. One product depends on a diffusion matrix in which nitroglycerin molecules are in equilibrium between lactose crystals and the liquid phase. In another product, micropockets of nitroglycerin are evenly dispersed throughout a silicone polymer which controls the drug release rate and prevents dose dumping.

A description of the different commercial products which deliver nitroglycerin transdermally is set forth by Dasta, et al., *American Pharmacy*, NS22, 2, 29-35, February 1982, which article also illustrates the various prior art nitroglycerin patches and their construction and operation, and which article is hereby incorporated by reference.

U.S. Pat. No. 4,336,243, issued June 22, 1982 describes transdermal nitroglycerin pads wherein the pad comprises a silicone polymer matrix being a cross-linked silicone rubber having from about 10 to 200 microns microseal compartments formed by the in situ cross-linking of the silicone rubber after it is admixed with a hydrophilic solvent containing the nitroglycerin in a hydrophobic solvent which enhances the dispersion and transport. U.S. Pat. No. 4,053,580, issued Oct. 11, 1977 describes an earlier pharmaceutical delivery device employing a silicone polymer matrix wherein the rate of release of the active ingredient is controlled by altering the solubility of the hydrophilic solvent system for the polymer matrix.

Another polymer diffusion matrix transdermal delivery system is described in published European patent application No. 80300038.9, of A. Keith entitled **Polymeric Diffusion Matrix and Method of Preparation and Drug Delivery Device Comprising Said Matrix**. This application describes a polymeric diffusion matrix composed of glycerol and polyvinyl alcohol together with a water-soluble polymer to provide a polymer matrix capable of sustained release of a drug dispersed in the matrix. Typically, the water-soluble polymer comprises a polyvinylpyrrolidone or a water-soluble cellulosic derivative. U.S. Pat. No. 3,797,494, issued Mar. 19, 1974 describes a transdermal bandage which includes a reservoir with a drug confined within the interior chamber of the reservoir and distributed throughout a reservoir matrix. In one embodiment the drug is released by a controlling microporous material, which microporous material meters the flow of the drug into the skin at a controlled rate. In another embodiment an adhesive coating is uniformly distributed through microcapsules comprising a drug encapsulated with a microporous rate controlling material.

While many transdermal drug delivery systems have been described as an economical and effective transdermal drug delivery system particularly for the delivery of contraceptive steroid drugs is still needed, and desired, particularly percutaneous delivery of steroid contraceptives in a controlled manner for periods of time ranging from one to four weeks or more.

Levonorgestrel is a synthetic steroid which has powerful progestational activity with minimal side effects at very low doses. Estradiol is a natural estrogen which has limited oral effectiveness because of "first pass" inactivation during circulation. On the other hand the synthetic steroid, ethinylestradiol, is active orally, since its inactivation by the liver and other tissues is very low. These contraceptives and others like Mestranol, Norethindrone, etc., are employed in various oral contraceptives manufactured in this country. Although levo-

norgestrel pills contain 150 micrograms of the drug, studies with implantable drug delivery systems indicate that only 30 micrograms per day are sufficient to prevent fertility.

Thus, it is desirable to provide an effective transdermal drug delivery system for the transdermal delivery of drugs, particularly contraceptive steroids.

SUMMARY OF THE INVENTION

The invention concerns a transdermal drug delivery system and a method of manufacture and use of such system. In particular the invention relates to a transdermal drug delivery system particularly useful for the controlled release of a contraceptive steroid drug or a combination of such drugs.

The invention relates to a transdermal drug delivery system which may be employed with a drug which is desired to be delivered transdermally at a controlled or sustained rate, typically a zero order rate or other delivery release patterns as desired. The transdermal drug delivery system of the invention prevents dose dumping of the drug caused by accidental rupture of the retaining member and ensures effective and prolonged delivery of the drug.

The invention relates to a method of and system for accelerating the transdermal delivery of drugs into a patient by sealing the skin of the patient with a thin layer of a viscous material to occlude the skin and transporting a desired dosage of a drug across the thin layer typically from a rate-controlling system in contact with the thin layer. The rate-controlling system may be a thin rate-controlling membrane interposed between the drug and the thin layer. Preferably the rate-controlling system comprises microparticles of the drug or a combination of drugs to be delivered suspended in the same or similar viscous material and contained within a container system. The container system generally comprises a macroporous non-rate-controlling face membrane with an impervious backing to form a pool or patch-like system of desired face membrane area with the face of the membrane placed over and in contact with the thin occluding viscous layer on the skin. The thin viscous layer may be coated or placed on the skin repeatedly and the patch system placed on top of the thin viscous layer or the viscous layer formed in situ by exudation through the membrane face when the patch or pool system is placed in position on the skin. The patch or pool container system generally is retained in a transdermal position by the use of a peripheral adhesive layer about the patch or pool. Typically the face or transport area of the membrane is covered prior to use by a removable cover such as a peelable strip of impervious sheet material.

In another embodiment microcapsules containing a drug for delivery may be suspended in a viscous material and the composition then spread as a layer over the skin of the user with or without a covering material.

The present drug delivery system for the transdermal delivery of medicaments is based on the use of solid microparticles. The system releases the drug from rate-controlling microparticles which are suspended in a dermatologically acceptable viscous liquid base. Drug release from microcapsules is controlled by microcapsule size and wall thickness. The system is also characterized by a macroporous membrane which delivers a thin liquid film of the base vehicle to the skin and whose function is to deliver the drug to the skin. The function of the viscous liquid film is to occlude the skin causing

the stratum corneum to swell and hydrate by forcing the diffusion of water from the lower layers of the epidermis and thus to accelerate the drug delivery. The first phase in transdermal delivery is dependent on the rate of diffusion of the drug within the vehicle and its rate of release from the vehicle. The drug concentration in the vehicle determines the thermodynamic activity and influences the diffusion of the drug out of the vehicle.

The present drug delivery system suspends drug/polymer microparticles, in a delivery vehicle which microparticles control the rate of release of the drug to the vehicle. Drug delivery from microcapsules is zero order provided solid particles are present inside the microcapsule in equilibrium with a saturated solution of the drug. It is dependent on the diffusion coefficient of the drug in the polymer, the thickness of the capsule wall, and the microcapsule dimensions in accordance with this equation:

$$\frac{dM}{dt} = 4\pi DK\Delta \frac{r_o r_i}{r_o - r_i}$$

Where M is the mass of the drug released, dM/dt is the steady state release rate at time t, DK is the membrane permeability, D is the diffusion coefficient of the drug in the membrane in cm^2/sec ., K is the distribution coefficient, C is the difference in drug concentration between the internal and external surface of the membrane, and r_o, r_i are the outer and inner radii of the capsule wall, respectively.

Drug release from monolithic microparticles such as microspheres is first order and is additionally dependent on drug concentration in the particle. Thus, the presence of the microparticles in the base vehicle helps to maintain a constant thermodynamic activity of the drug in the vehicle by insuring that the concentration of the drug is close to saturation.

The delivery of the vehicle to the skin is regulated by a macroporous membrane (for example ranging from about 1 to 1000 microns) whose properties and pore size are selected to match those of the base vehicle. A hydrophobic membrane, for example, is best used with a hydrophobic delivery base vehicle and hydrophilic membrane with a hydrophilic vehicle while smaller micron pores e.g. 50 to 200 deliver a smaller quantity of the vehicle than larger micron pores e.g. 300 to 600.

The principal barrier to permeation of small molecules through the skin is provided by the stratum corneum or "horny layer" of cells which is about 10 to 15 microns thick. This layer is composed of a dispersion of hydrophilic proteins in a continuous lipid matrix. The lipid component of the layer which comprise only 20-30% of the weight of the tissue are directly responsible for its unique low permeability (Scheuplein, 1971). The stratum corneum may be regarded as a passive diffusion membrane, albeit not entirely inert, which follows Fick's Law in which the steady state flux J_s is:

$$J_s = \frac{K_m D C_s}{S}$$

$$\text{where } K_m = \frac{\text{solute sorbed per cc of tissue}}{\text{solute in solution per cc solvent}} = \frac{C_m}{C_s}$$

C_s = concentration difference of solute across membrane

Explore Litigation Insights

Docket Alarm provides insights to develop a more informed litigation strategy and the peace of mind of knowing you're on top of things.

Real-Time Litigation Alerts



Keep your litigation team up-to-date with **real-time alerts** and advanced team management tools built for the enterprise, all while greatly reducing PACER spend.

Our comprehensive service means we can handle Federal, State, and Administrative courts across the country.

Advanced Docket Research



With over 230 million records, Docket Alarm's cloud-native docket research platform finds what other services can't. Coverage includes Federal, State, plus PTAB, TTAB, ITC and NLRB decisions, all in one place.

Identify arguments that have been successful in the past with full text, pinpoint searching. Link to case law cited within any court document via Fastcase.

Analytics At Your Fingertips



Learn what happened the last time a particular judge, opposing counsel or company faced cases similar to yours.

Advanced out-of-the-box PTAB and TTAB analytics are always at your fingertips.

API

Docket Alarm offers a powerful API (application programming interface) to developers that want to integrate case filings into their apps.

LAW FIRMS

Build custom dashboards for your attorneys and clients with live data direct from the court.

Automate many repetitive legal tasks like conflict checks, document management, and marketing.

FINANCIAL INSTITUTIONS

Litigation and bankruptcy checks for companies and debtors.

E-DISCOVERY AND LEGAL VENDORS

Sync your system to PACER to automate legal marketing.