

(12) INTERNATIONAL APPLICATION PUBLISHED UNDER THE PATENT COOPERATION TREATY (PCT)

(19) World Intellectual Property Organization
International Bureau



(43) International Publication Date
10 May 2001 (10.05.2001)

PCT

(10) International Publication Number
WO 01/32259 A1

- (51) International Patent Classification⁷: A61N 1/05 LASKE, Timothy, G.; 5820 Evergreen Lane, Shoreview, MN 55126 (US).
- (21) International Application Number: PCT/US00/27833
- (22) International Filing Date: 10 October 2000 (10.10.2000)
- (25) Filing Language: English
- (26) Publication Language: English
- (30) Priority Data:
09/430,890 1 November 1999 (01.11.1999) US
- (71) Applicant: MEDTRONIC, INC. [US/US]; 7000 Central Avenue NE, Minneapolis, MN 55432 (US).
- (72) Inventors: HUEPENBECKER, Georges, M.; 3450 Montmorency, Vadnais Heights, MN 55110 (US).
- (74) Agents: WOLDE-MICHAEL, Girma et al.; Medtronic, Inc., 7000 Central Avenue NE, Minneapolis, MN 55432 (US).
- (81) Designated States (national): CA, JP.
- (84) Designated States (regional): European patent (AT, BE, CH, CY, DE, DK, ES, FI, FR, GB, GR, IE, IT, LU, MC, NL, PT, SE).
- Published:**
— With international search report.
- For two-letter codes and other abbreviations, refer to the "Guidance Notes on Codes and Abbreviations" appearing at the beginning of each regular issue of the PCT Gazette.*



(54) Title: HIGH STRENGTH MEDICAL ELECTRICAL LEAD

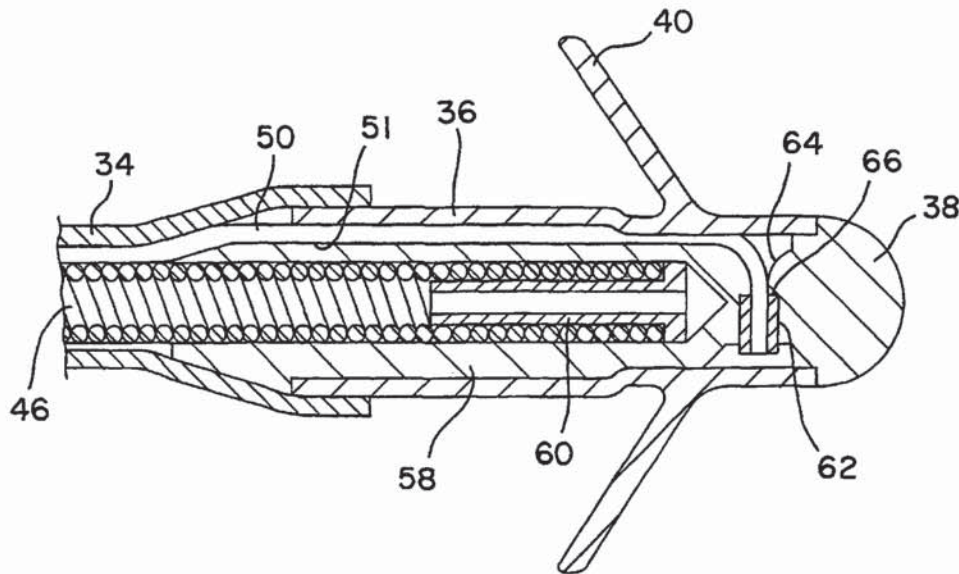

WO 01/32259 A1

(57) Abstract: An implantable electrical lead having at least two mutually insulated electrical components (30, 38) that are separated by a portion of the lead's body fabricated of a pliant, extensible biocompatible insulated material. An extensible conductor (44) extends from the proximal end of the lead body to a first one of the electrical components, and a second, inextensible conductor (42) extends from the proximal end of the lead body to a second one of the electrical components. An inextensible reinforcement member (50) is coupled to the inextensible conductor and extends distally from the second electrical component to the first electrical

HIGH STRENGTH MEDICAL ELECTRICAL LEAD

Background of the Invention

The present invention relates to implantable medical leads generally and more particularly to multi-conductor implantable leads employing coiled conductors that extend
5 to a distal portion of the lead.

In the context of implantable pacing and cardioversion leaves, it is desirable that the lead be provided with a tensile member that extends along the entire length of the lead. Such a tensile member is desirable in that it prevents disassembly of the lead in response to traction forces applied to the proximal end of the lead, in conjunction with removal of the
10 lead after implant. One approach to providing such a longitudinal reinforcement is set forth in U.S. Patent No. 5,231,996 issued to Bardy et al, which suggests adding a nonconductive tensile reinforcing member from the connector assembly at the proximal end of the lead to an electrode located at the distal end of the lead. An alternative approach to providing a tensile member extending the length of the lead is set forth in U.S. Patent Application
15 SN08/938,269 by Bischoff et al., filed on September 27, 1997, which discloses a structure in which the tip and ring electrode are mounted to a rigid plastic head and the conductor extending from the proximal end of the lead to the ring electrode is mechanically interconnected with the rigid plastic head. The disadvantage with the approach set forth in the Bardy et al patent is that it requires an additional tensile member extending the entire
20 length of the lead, which in turn generally increases in the required diameter of the lead body over the majority of its length. Although the approach set forth in the above-cited Bischoff et al. application avoids the problem of an increased lead diameter, it requires a rigid member interconnecting the ring electrode and the tip electrode in order to provide tensile reinforcement all the way to the distal electrode. In the context of tined leads or
25 other leads in which a coiled conductor is used to connect to the tip electrode and in which the portion of the lead body intermediate the tip electrode and electrodes located proximal thereto is typically fabricated out of a flexible elastomer, the approach of the Bischoff et al. application is not readily applicable.

Summary of the Invention

The present invention is directed toward a provision of a pacing or cardioversion lead of the type having a distal or tip electrode and one or more electrodes located proximal to the tip electrode, separated therefrom by a flexible lead body segment, and having a
5 coiled conductor extending from the proximal end of the lead to the tip electrode, permitting passage of a stylet. In such leads, the coiled conductor does not prevent stretching and breaking of the flexible lead body segment between the tip electrode and the electrode located most closely proximal thereto and has the potential for causing serious problems during attempted extractions of the lead, in that the coiled conductor is capable of
10 significant longitudinal extension. The present invention provides a mechanism for providing a reinforcement extending the entire length of the lead body, in such a lead, without the disadvantage of an over-all increase in lead body diameter.

The present invention accomplishes the objects discussed above by means of a reinforcement member which is mechanically coupled to and extends distally from an
15 inextensible conductor coupled to an electrode or sensor located proximal to the tip electrode, and which in turn is mechanically coupled to the tip electrode located at the distal end of the lead. The reinforcement member mechanically couples but does not electrically couple the inextensible conductor and the tip electrode. Because the reinforcement extends from the distal termination of a lead conductor, it can occupy the
20 portion of the lead body that the lead conductor occupies in portions of the lead body proximal thereto, avoiding the necessity for an increased lead body diameter along the entire length of the lead. The reinforcement member is preferably non-conductive but may be conductive if insulated from the inextensible conductor to which it is coupled and/or from the distal or tip electrode. Limiting the reinforcement member to a distal portion of
25 the lead also simplifies construction of the lead, in that it requires no additional interconnections to be made between the reinforcement member and the connector assembly at the proximal end of the lead. The reinforcement member is preferably coupled to the largest and/or strongest of the inextensible conductors within the lead body.

Brief Description of the Drawings

Figure 1 is a plan view of a lead according to the present invention.

Figure 2 is a cross section through the lead body in the portion of the lead proximal to the coiled defibrillation electrode 60.

5 Figure 3 illustrates a cross section of the lead taken in the vicinity of the distal end of defibrillation electrode 30

Figure 4 illustrates a cross-section through the lead in the vicinity of tip electrode 38.

Detailed Description of the Embodiment

10 Figure 1 is a plan view of a lead according to the present invention. The lead is provided with an elongated insulative lead body 10, which terminates at its proximal extremity in a molded bifurcation member 12, from which two connector assemblies 14 and 16 extend. Connector assembly 14 carries a single connector pin 18 and associated sealing rings 20 for sealing the connector assembly in the bore of an implantable cardiac
15 pacemaker/cardioverter/defibrillator. Connector assembly 16 carries a connector ring 22 and a connector pin 24 and associated sealing rings 26 and 28 for sealing the connector assembly. The distal portion of the lead body carries an elongated coiled defibrillation electrode 30, coupled to connector pin 18 internally by means of an elongated, inextensible stranded conductor. Located distal to defibrillation electrode 30 is a ring electrode 32, in
20 turn coupled to connector ring 22 by a second, elongated, inextensible stranded conductor. At the distal end of the lead is a tip electrode 38 which is connected to connector pin 24 by an elongated, extensible, coiled conductor, configured so that a stylet may pass through connector pin 24 to the distal end of the lead at or adjacent electrode 38. Electrode 38 is provided with an internal electrode shank, around which insulative tine sleeve 36 is
25 mounted. The lead is optionally provided with tines 40 to assist in acute fixation of the electrode 38 in the right ventricular apex. Separating tip electrode 38 and ring electrode 32 is a tip-ring spacer 34, which is, fabricated of a pliant elastomeric material such polyurethane or silicone rubber tubing.

30 Figure 2 is a cross section through the lead body in the portion of the lead proximal to the coiled defibrillation electrode 30. In this view it can be seen that the lead body 10 is

provided with three internal lumens carrying two inextensible, stranded conductors 42 and 44 which may correspond to the conductors disclosed in U.S. Patent No. 5,246,014 issued to Williams et al or U.S. Patent No. 5,584,873 issued to Shoberg et al, both of which are incorporated herein by reference in their entireties. Conductor 42 extends from connector pin 22 (Figure 1) to ring electrode 32, and conductor 44 extends from connector pin 18 to defibrillation electrode 30. In the embodiment illustrated, conductor 34 has a greater diameter, as a result of its need for higher current carrying capabilities in conjunction with delivery of cardioversion and defibrillation pulse energies to electrode 30. Conductor 34 correspondingly has a higher tensile strength and is the conductor to which the nonconductor reinforcement member is coupled as illustrated in Figure 3 below.

Figure 3 illustrates a cross section of the lead taken in the vicinity of the distal end of defibrillation electrode 30. In this view, the interconnection of stranded conductor 44 and defibrillation electrode 30 is illustrated. These two elements of the lead are interconnected by means of a cross-groove crimp sleeve generally as described in U.S. Patent No. 5,676,694, issued to Boser et al. and incorporated herein by reference in its entirety. Like the cross-groove crimp sleeve in the Boser et al. patent, cross-groove crimp sleeve 48 is provided with an elongated tubular section in which the distal termination of conductor 44 is located, and in which it is maintained by means of crimps 54. The crimp sleeve 48 is provided with a laterally extending projection, which carries a groove 49 in which the distal end of defibrillation electrode 30 is located and welded in order to provide a mechanical and electrical interconnection with conductor 44. Unlike the cross-groove crimp sleeve of the Boser et al. patent, the cylindrical portion of the crimp sleeve 48 extends distally to the laterally extending shoulder, providing a lumen in which tensile member 50 may be inserted and in which tensile member 50 is maintained by means of crimps 52.

Tensile member 50 may take the form of a monofilament or stranded cord fabricated of a high tensile strength, nonconductive plastic or fiber, for example, ultra-high molecular weight polyethylene or polyester. Tensile member 50 may also be adhesively coupled to the interior of cross-groove crimp sleeve 48, if desired. Tensile member 50 extends to and is mechanically connected to tip electrode 38 (Figure 1) as illustrated in

Explore Litigation Insights

Docket Alarm provides insights to develop a more informed litigation strategy and the peace of mind of knowing you're on top of things.

Real-Time Litigation Alerts



Keep your litigation team up-to-date with **real-time alerts** and advanced team management tools built for the enterprise, all while greatly reducing PACER spend.

Our comprehensive service means we can handle Federal, State, and Administrative courts across the country.

Advanced Docket Research



With over 230 million records, Docket Alarm's cloud-native docket research platform finds what other services can't. Coverage includes Federal, State, plus PTAB, TTAB, ITC and NLRB decisions, all in one place.

Identify arguments that have been successful in the past with full text, pinpoint searching. Link to case law cited within any court document via Fastcase.

Analytics At Your Fingertips



Learn what happened the last time a particular judge, opposing counsel or company faced cases similar to yours.

Advanced out-of-the-box PTAB and TTAB analytics are always at your fingertips.

API

Docket Alarm offers a powerful API (application programming interface) to developers that want to integrate case filings into their apps.

LAW FIRMS

Build custom dashboards for your attorneys and clients with live data direct from the court.

Automate many repetitive legal tasks like conflict checks, document management, and marketing.

FINANCIAL INSTITUTIONS

Litigation and bankruptcy checks for companies and debtors.

E-DISCOVERY AND LEGAL VENDORS

Sync your system to PACER to automate legal marketing.