



US005206934A

United States Patent [19] Naef, III

[11] Patent Number: **5,206,934**
[45] Date of Patent: **Apr. 27, 1993**

- [54] **METHOD AND APPARATUS FOR INTERACTIVE COMPUTER CONFERENCING**
- [75] Inventor: **Frederick E. Naef, III, Reston, Va.**
- [73] Assignee: **Group Technologies, Inc., Arlington, Va.**
- [21] Appl. No.: **393,876**
- [22] Filed: **Aug. 15, 1989**
- [51] Int. Cl.⁵ **G06F 15/16**
- [52] U.S. Cl. **395/200; 364/DIG. 1; 364/228.3; 364/228.4; 364/229; 364/259.9; 364/259**
- [58] **Field of Search** ... 364/200 MS File, 900 MS File; 395/200, 375

Build a Network Painting Program", *MacTutor*, vol. 5, No. 7, pp. 28-51 (Jul. 1989).
 J. Langowski, "Forth Forum-Appletalk Protocol Handlers", *MacTutor*, vol. 5, No. 7, pp. 52-57 (Jul. 1989).
 M. Stefik et al., "Beyond the Chalkboard: Computer Support for Collaboration and Problem Solving in Meetings", *Communications of the ACM*, vol. 30, No. 1, pp. 32-47 (Jan. 1987).
 S. Sarin and I. Greif, "Computer-Based Real-Time Conferencing Systems", *Computer*, vol. 18, No. 10, pp. 33-45 (Oct. 1985).
 H. Forsdick et al., "Initial Experience with Multimedia Documents in Diamond", *Computer Message Service, Proceedings of IFIP 6.5 Working Conference*, IFIP, pp. 97-112 (1984).
 W. Pferd et al., "Interactive Graphics Teleconferencing", *Computer*, vol. 12, No. 11, pp. 62-72 (Nov. 1979).
 M. Brown and R. Sedgewick, "Techniques for Algorithm Animation", *IEEE Software*, vol. 2, No. 1, pp. 28-39 (Jan. 1985).

Primary Examiner—Kevin A. Kriess
Attorney, Agent, or Firm—Venable, Baetjer & Howard

[56] **References Cited**
U.S. PATENT DOCUMENTS

4,414,621	11/1983	Bown et al.	364/200
4,441,162	4/1984	Lillie	364/900
4,493,021	1/1985	Agrawal et al.	364/200
4,503,499	3/1985	Mason et al.	364/200
4,551,720	11/1985	Levin	340/825
4,654,483	3/1987	Imai et al.	379/54
4,686,698	8/1987	Tompkins et al.	379/53
4,718,005	1/1988	Feigenbaum et al.	364/200
4,768,150	8/1988	Chang et al.	364/300
4,777,595	10/1988	Strecker et al.	364/200
4,780,821	10/1988	Crossley	364/200
4,796,293	1/1989	Blinken et al.	379/202
4,814,984	3/1989	Thompson	364/200
4,825,354	4/1989	Agrawal et al.	364/200
4,887,204	12/1989	Johnson et al.	364/200
4,897,781	1/1990	Chang et al.	364/200
4,937,784	6/1990	Masai et al.	364/900
4,939,509	7/1990	Bartholomew et al.	340/717
4,949,248	8/1990	Caro	364/200
4,949,254	8/1990	Shorter	364/200
5,008,853	4/1991	Bly et al.	364/900

[57] **ABSTRACT**

A method and apparatus for conferencing among a plurality of computers is described. A local user receives inputs containing user actions and data for interpretation as to what the user action is with respect to the data and produces user action outputs. An interpreter/encoder interprets and encodes the user action outputs into packets of encoded commands and data related thereto. A communications device sends the encoded information to at least one remote user and the local user itself. An interpreter decoder at each computer interprets and decodes the encoded information specifying an operation to be performed on the data. The operation is then executed at the local user and the remote users. The system is operating system independent and multiple documents and applications may be worked on at the same time by different users.

OTHER PUBLICATIONS

E. Circenis and R. Magnuson, "Pascal Procedures--"

34 Claims, 5 Drawing Sheets

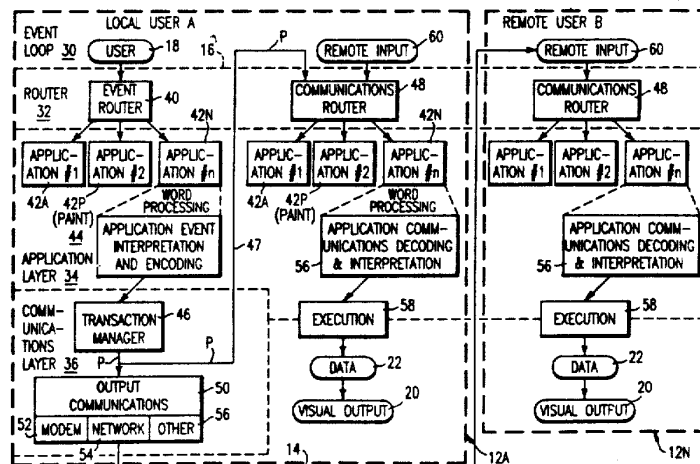

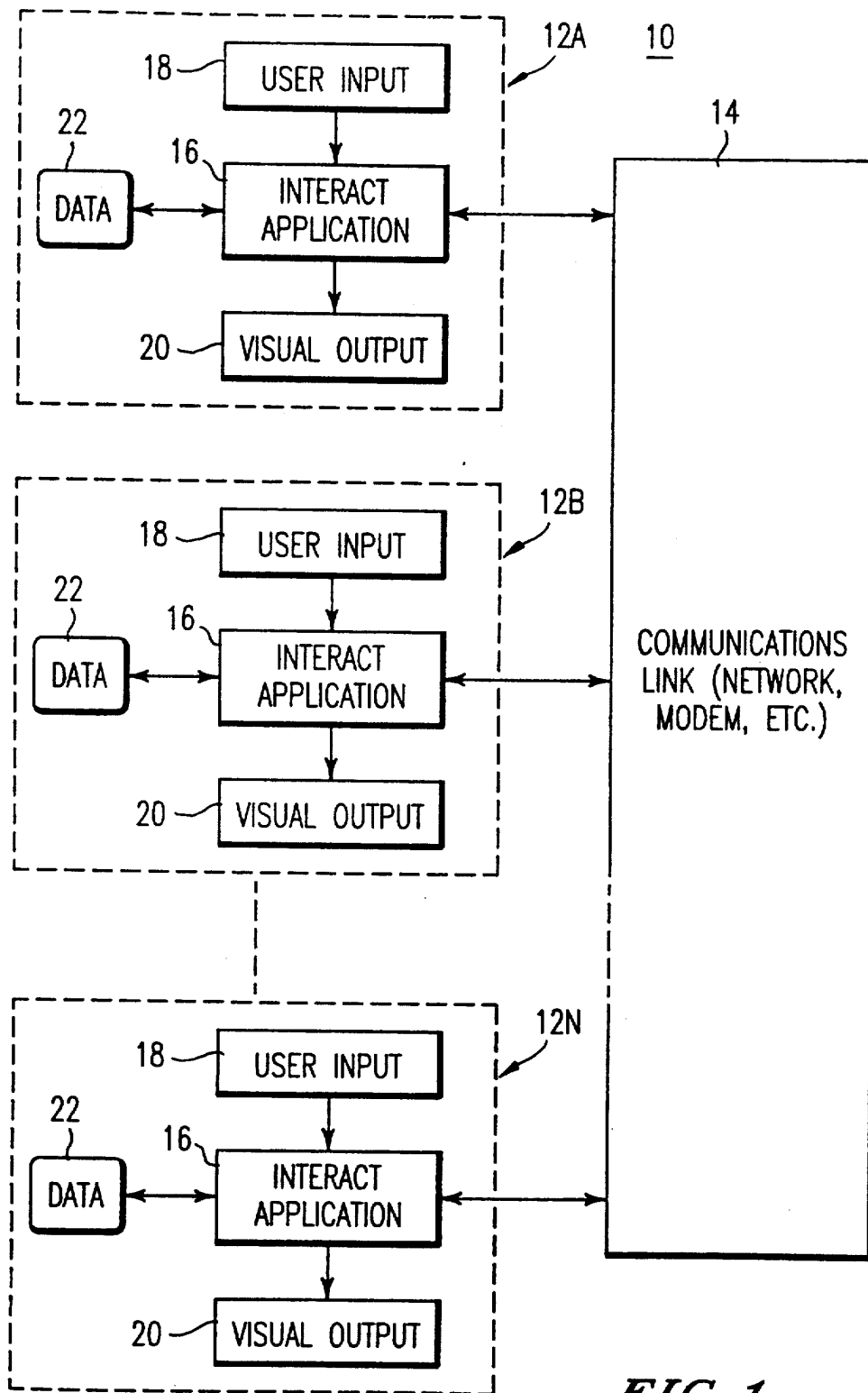

FIG. 1

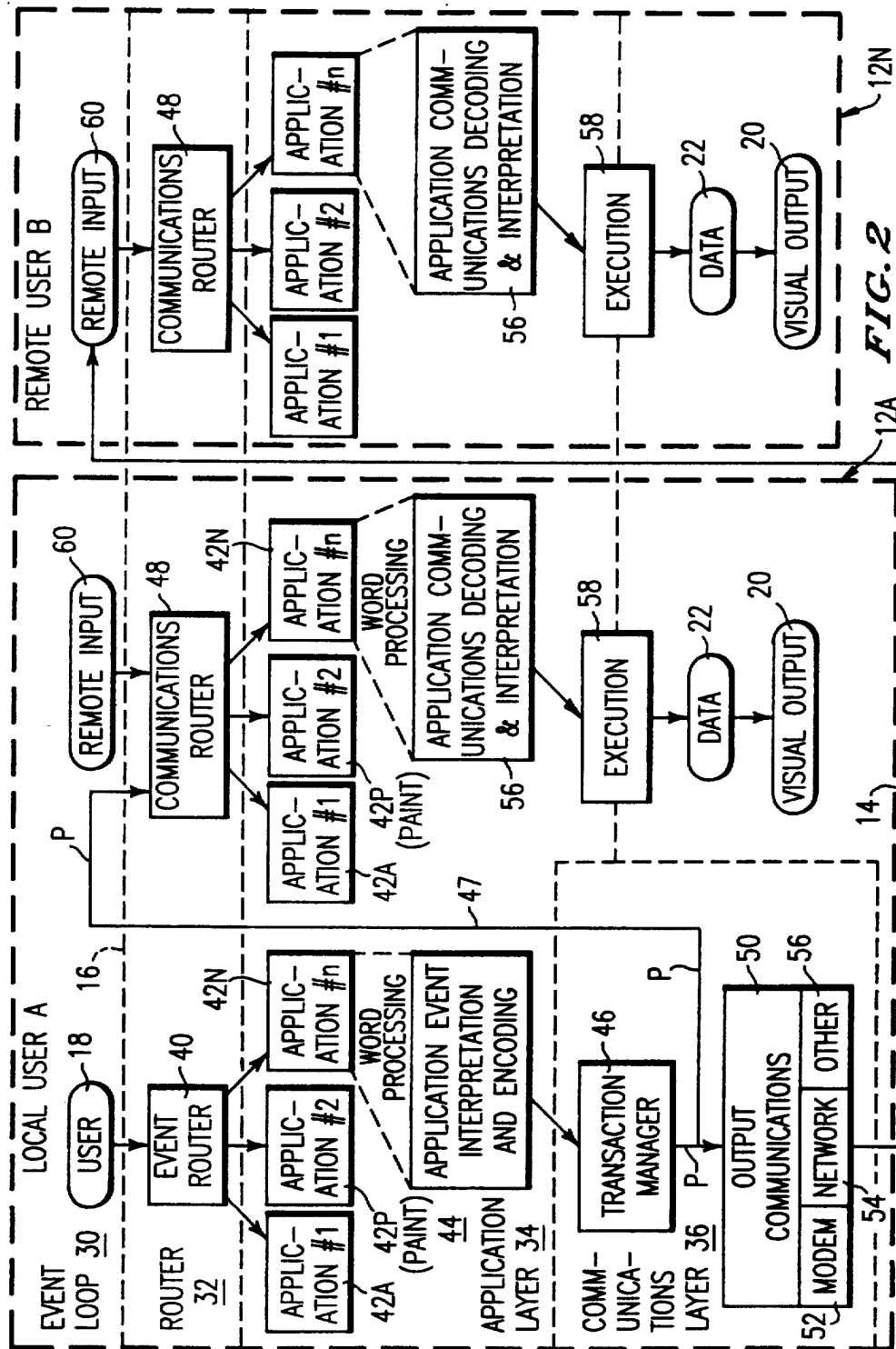

FIG. 2

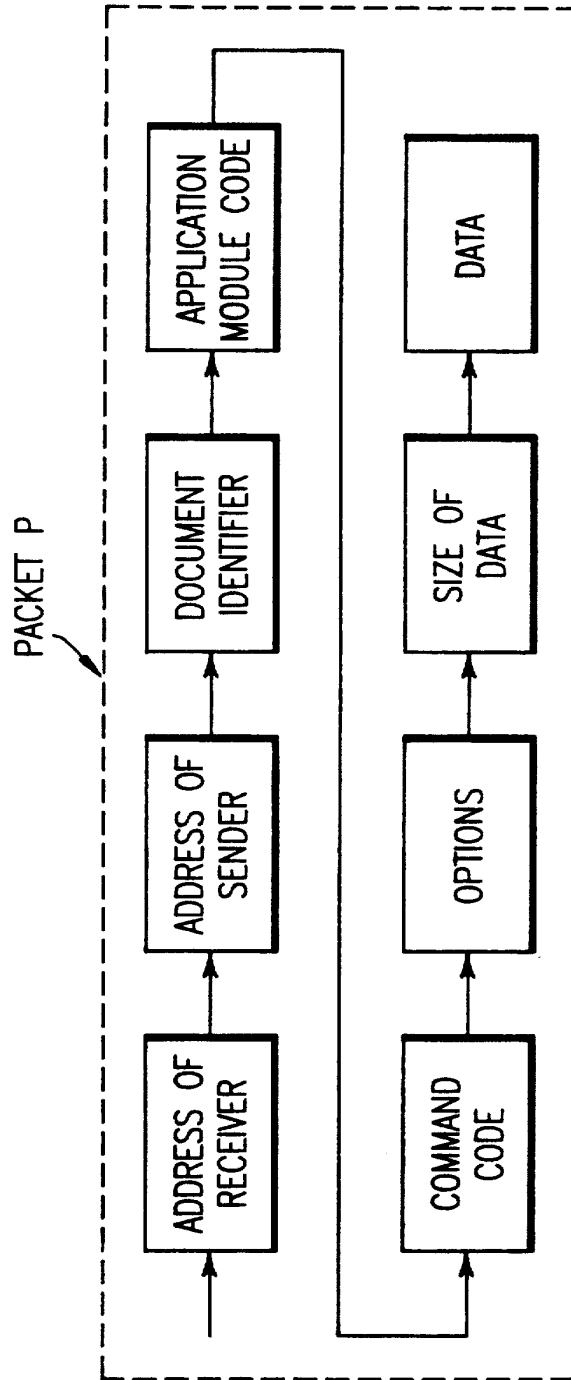

FIG. 3

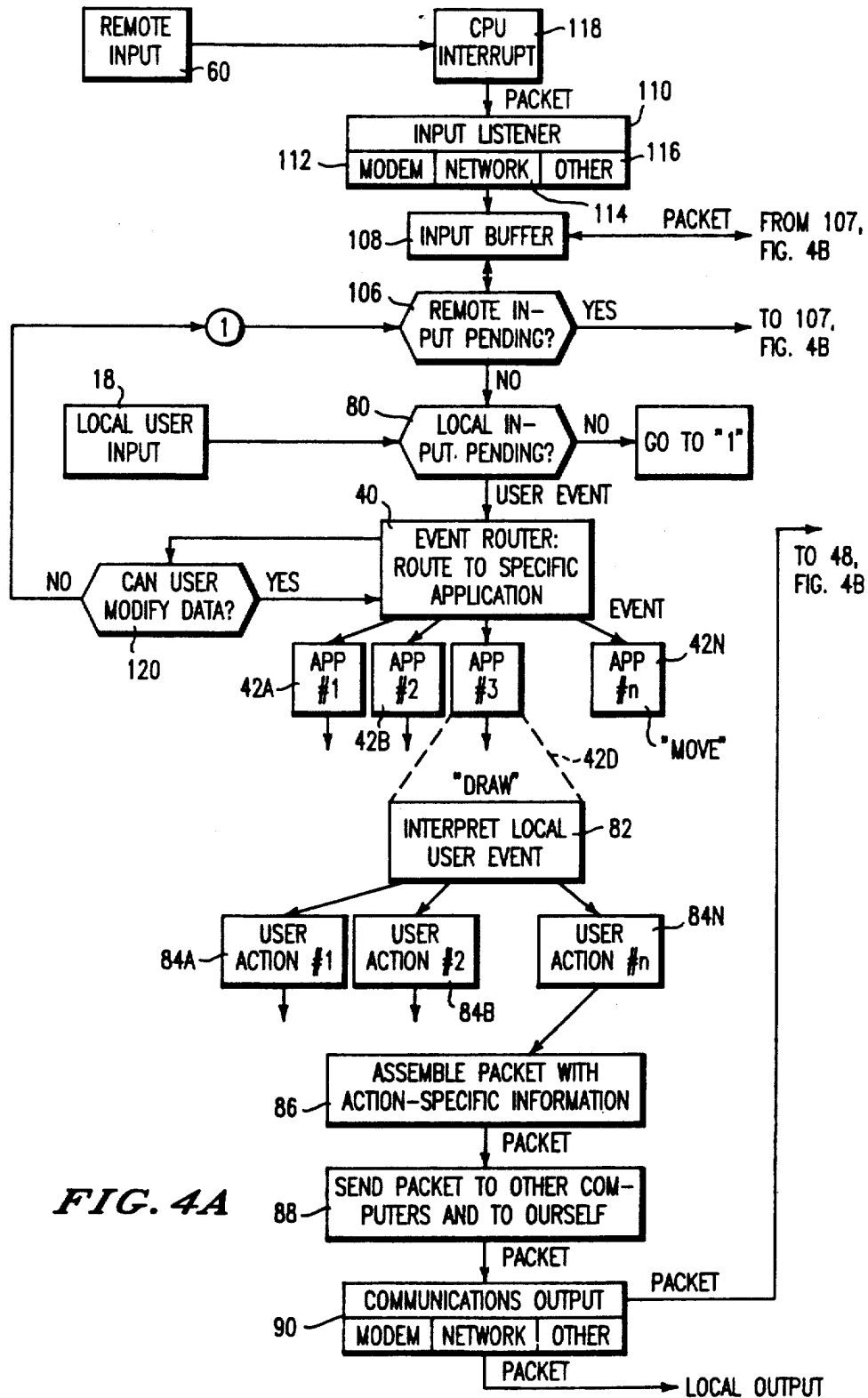

FIG. 4A

Explore Litigation Insights

Docket Alarm provides insights to develop a more informed litigation strategy and the peace of mind of knowing you're on top of things.

Real-Time Litigation Alerts



Keep your litigation team up-to-date with **real-time alerts** and advanced team management tools built for the enterprise, all while greatly reducing PACER spend.

Our comprehensive service means we can handle Federal, State, and Administrative courts across the country.

Advanced Docket Research



With over 230 million records, Docket Alarm's cloud-native docket research platform finds what other services can't. Coverage includes Federal, State, plus PTAB, TTAB, ITC and NLRB decisions, all in one place.

Identify arguments that have been successful in the past with full text, pinpoint searching. Link to case law cited within any court document via Fastcase.

Analytics At Your Fingertips



Learn what happened the last time a particular judge, opposing counsel or company faced cases similar to yours.

Advanced out-of-the-box PTAB and TTAB analytics are always at your fingertips.

API

Docket Alarm offers a powerful API (application programming interface) to developers that want to integrate case filings into their apps.

LAW FIRMS

Build custom dashboards for your attorneys and clients with live data direct from the court.

Automate many repetitive legal tasks like conflict checks, document management, and marketing.

FINANCIAL INSTITUTIONS

Litigation and bankruptcy checks for companies and debtors.

E-DISCOVERY AND LEGAL VENDORS

Sync your system to PACER to automate legal marketing.