

that update messages are exchanged by servers periodically, indicating messages are exchanged at fixed, regular intervals of time. RING at p. 87.

CLAIM 3

The method of claim 1 wherein said time interval corresponds to a time for said server to receive at least one message from each host computer belonging to said first message group.

RING, in view of Netrek, discloses the method of claim 1 wherein said time interval is a fixed period of time. RING at Abstract, pp. 85, 86, 87, 90 and 91. In particular, RING discloses that update messages are exchanged by servers periodically, indicating messages are exchanged at fixed, regular intervals of time. RING at p. 87. Furthermore, Netrek discloses a *readFromClient* function that receives messages from each of the hosts (*e.g.*, clients) into a shared memory (*e.g.*, “buf”). See *Server\ntserv\input.c* at line 195 and *Server\ntserv\socket.c* at lines 1825-2044. Netrek further discloses a time for the server to receive at least one message from each host—each host that joins has a corresponding *ntserv* process running on the server, which waits 0.2 seconds for at least one message to aggregate in *buf* from each host computer belonging to the first message group (*e.g.*, all players in the game or on a particular team)—and after waiting the 0.2 seconds, the aggregated messages are sent to the clients. See *Server\ntserv\socket.c* at lines 1825-2044, 603-90; *Server\ntserv\input.c* at lines 152-203; *Server\ntserv\redraw.c* at lines 21-115. One of ordinary skill in the art would have looked to Netrek to teach a time interval to receive at least one message from each host computer as both Netrek and RING involve exchanging packets of positional information in a gaming environment on a unicast network in order to maintain consistency in the virtual world and increase efficiency in message distribution.

CLAIM 4

The method of claim 1 further comprising the step of creating, by one of said plurality of host computers, said first message group by sending a first control message to said server via said unicast network.

RING discloses creating the first message group by sending a first control message to the server using the unicast network; for example, when a first player enters a “hexagonal shaped cell,” they create a message group consisting of the first player, and when other players enter the same “hexagonal shaped cell,” they join the message group created by the first player. RING at p. 90-91. More specifically, the server creates the “hexagonal shaped cell,” but the first player

entering the cell creates the first message group, which comprises the players in the cell. *Id.* Therefore, RING discloses the creation of the first message group when people enter the “hexagonal shaped cell.” *Id.*

CLAIM 5

The method of claim 4 further comprising the step of joining, by some of said plurality of host computers, said first message group by sending control messages via said unicast network to said server specifying said first message group.

RING discloses additional host computers joining the first message group by sending control messages (*e.g.*, “update messages”) to the server indicating that they are joining the message group created by the first player. RING at pp. 89.

CLAIM 6

The method of claim 1 wherein said network is Internet and said server communicates with said plurality of host computers using a session layer protocol.

RING discloses the method of claim 1 wherein the network is the Internet (*e.g.*, a wide-area network”) and the server communicates with a plurality of host computers (*e.g.*, “client workstations”) using a session layer protocol because RING discloses UDP/IP and application layer protocols that include session layer functionality. RING at Abstract, pp. 85, 86, 87, 89, 90, 91 and Fig. 11. The wide-area network disclosed by RING includes the Internet because RING uses the UDP/IP protocol, which is a member of the Internet Protocol Suite, the set of network protocols used for the Internet. RING at pp. 89, 85 and Fig. 11.

F. CLAIMS 1, 2 AND 4-6 ARE RENDERED OBVIOUS BY RING IN VIEW OF VAN HOOK UNDER 35 U.S.C. § 103

Please see the attached Exhibit CC-F presenting claim charts for comparison of RING in view of Van Hook with claims 1, 2 and 4-6 of the ‘523 patent.

Reasons to Combine:

RING discloses communicating messages over a network. RING at Figs. 5 and 7, pp. 88, 87 and 91. RING does not disclose aggregating payloads into a single aggregated message, but Van Hook discloses aggregating group messages into a single packet by bundling the packets. Van Hook at 2. Van Hook states that “[t]he dominant effect of bundling is to reduce packet rates. Additionally, bundling reduces bit rates because fewer packet headers are sent.” *Id.*

Therefore, one of ordinary skill in the art would have looked to Van Hook to aggregate group messages in order to reduce bit rates and increase the network efficiency of RING.

CLAIM 1

A method for providing group messages to a plurality of host computers connected over a unicast wide area communication network, comprising the steps of:

RING discloses a method for providing group messages (e.g., “update messages”) to a plurality of host computers (e.g., “client workstations”) connected over RING’s unicast wide-area communication network. RING at Abstract, pp. 85, 86, 90 and 91.

providing a group messaging server coupled to said network, said server communicating with said plurality of host computers using said unicast network and maintaining a list of message groups, each message group containing at least one host computer;

RING discloses providing a group messaging server coupled to the network, (e.g., RING’s unicast wide-area communication network), wherein the server communicates with the plurality of host computers (e.g., “client workstations”) using the unicast network and maintaining a list of message groups. RING at Figs. 5 and 7, pp. 88, 87 and 91. As illustrated in Figure 7 (reproduced below), for example, RING discloses that clients A and C belong to client B’s message group, and therefore this particular message group contains at least one host computer, or client workstation, including A, B and C. RING at Fig. 7.

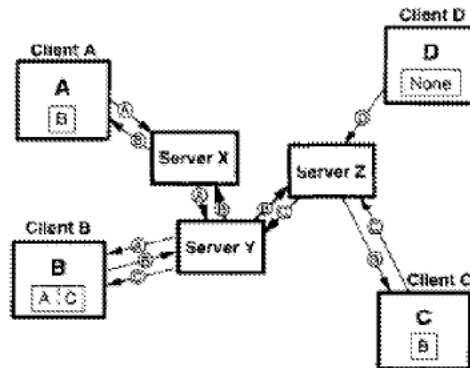

Figure 7: Flow of update messages (labeled arrows) for updates to entities A, B, C, and D arranged in a virtual environment as shown in Figure 4.

Figure 7 of RING at p. 88.

Message groups can consist of all clients connected to RING servers, or clients that are visible to each other and can send messages to each other. RING at pp. 87-88. A server, such as server Y in Figure 7, maintains a list of message groups, as “servers keep track of which cells contain which entities by exchanging ‘periodic’ update messages when entities cross cell boundaries,” and thus become visible to other clients. RING at p. 87.

sending, by a plurality of host computers belonging to a first message group, messages to said server via said unicast network, said messages containing a payload portion and a portion for identifying said first message group;

RING discloses sending, by a plurality of host computers (*e.g.*, “client workstations”) belonging to a first message group (*i.e.* other clients participating in the same distributed simulation and in the same cell), messages to the server via the unicast network. RING at pp. 87 and 91. The messages (*e.g.*, “update messages”) contain 40 bytes, and consist of a portion for identifying a first message group, such as an “entity-ID” as well as a payload portion containing message information such as “target-position,” “target-orientation,” “positional-velocity,” and “rotational velocity.” RING at pp. 87, 89, 91 and Fig. 5. While the entity-ID does not explicitly indicate a particular message group, it is used by the server “for identifying” the group (*e.g.*, “cell”) to which the message should be transmitted. RING at p. 87 (“[S]ervers keep track of which cells contains which entities by exchanging “periodic” update message when entities cross cell boundaries. Real-time update messages are propagated only to servers and client containing entities inside some cell visible to the one containing the updated entity.”)

aggregating, by said server in a time interval determined in accordance with a predefined criterion, said payload portions of said messages to create an aggregated payload;

While RING does not explicitly disclose aggregating, Van Hook discloses aggregating (*e.g.*, “bundling”), by said server (*e.g.*, “Application Gateway”)(AG) in a time interval determined in accordance with a predefined criterion (“maximum packet size” or “maximum time”) payload portions of said messages (*e.g.*, “Data messages, called protocol data units (PDUs)”) to create an aggregated payload (*e.g.*, “bundled PDU”). Van Hook at pp. 2 and 7.

Similarly, RING uses message groups like those of Van Hook (*e.g.*, participants in proximity with each other) when processing what information should be sent to servers and clients. RING at p. 87. Therefore, it would have been obvious to one of skill in the art to use the teaching of aggregating message payloads from clients based on the bundling of messages

disclosed in Van Hook to aggregate update message payloads in RING to increase network efficiency.

forming an aggregated message using said aggregated payload; and

While RING does not explicitly disclose forming an aggregated message, it teaches that it is advantageous to aggregate (*e.g.*, “augment”) a client message payload (*e.g.*, an “update message”) with “Add” and “Remove” messages. RING at p. 88 (“As entities move through the environment, servers augment update messages with ‘Add’ and ‘Remove’ messages notifying clients that remote entities have become relevant or irrelevant to the client’s local entities.”).

Moreover, Van Hook discloses forming an aggregated message (*e.g.*, “bundled PDU”) using said aggregated payload. Van Hook at pp. 2.

transmitting, by said server via said unicast network, said aggregated message to a recipient host computer belonging to said first message group.

RING, in view of Van Hook, discloses transmitting, by said server via said unicast network, said aggregated message to a recipient host computer (*e.g.*, “client workstation”) belonging to said first message group. RING at pp. 87 and 91. More specifically, “RING routes each one through at least one server and possibly two.” RING at p. 88. According to RING, client workstations belong to the first message group if they participate in the same distributed simulation or are visible to each other. RING at p. 87.

Moreover, Van Hook discloses transmitting said aggregated message (*e.g.*, “bundled PDU”) onto the WAN. Van Hook at 7. The other AGs on the WAN receive the aggregated message (*e.g.*, “bundled packet”), unbundle it, and determine which hosts in the group (*e.g.*, “cell set,” “Force ID” or “Exercise ID”) should receive the PDU. The AG then transmits the PDUs individually to those recipient host computer in the group (*e.g.*, “cell set”). Van Hook at Figures 1 and 5; pp. 1, 2, 4, 6, 7.

The recipient host computer does not receive the aggregated message (*e.g.*, “bundled PDU”) because it is unbundled by an AG after being received from the WAN and before being retransmitted to the host computer over the LAN. Van Hook at 7, section 4.6. Nevertheless, Requester submits that the broadest reasonable interpretation of this element does not require receiving, by a recipient host computer, said aggregated message. Instead, the step of “transmitting said aggregated message...” is performed when the AG transmits the bundled PDU

out onto the WAN, even though the packet may be de-aggregated prior to being received by the recipient host computer.

CLAIM 2

The method of claim 1 wherein said time interval is a fixed period of time.

RING discloses the method of claim 1 wherein said time interval is a fixed period of time. RING at Abstract, pp. 85, 86, 87, 90 and 91. In particular, RING discloses that update messages are exchanged by servers periodically, indicating messages are exchanged at fixed, regular intervals of time. RING at p. 87. Moreover, Van Hook discloses aggregation of packets (*e.g.*, “packets may be bundled together”) to avoid overloading computers. Van Hook at pp. 2 and 7.

CLAIM 4

The method of claim 1 further comprising the step of creating, by one of said plurality of host computers, said first message group by sending a first control message to said server via said unicast network.

RING discloses creating the first message group by sending a first control message to the server by the unicast network; for example, when a first player enters a “hexagonal shaped cell,” they create a message group consisting of the first player and when other players enter the same “hexagonal shaped cell,” they join the message group created by the first player. RING at p. 90-91. More specifically, the server creates the “hexagonal shaped cell,” but the first player entering the cell creates the first message group, which comprises the players in the cell. *Id.* Therefore, RING discloses the creation of the first message group when people enter the “hexagonal shaped cell.” *Id.*

CLAIM 5

The method of claim 4 further comprising the step of joining, by some of said plurality of host computers, said first message group by sending control messages via said unicast network to said server specifying said first message group.

RING discloses additional host computers joining the first message group by sending control messages (*e.g.*, “update messages”) to the server indicating that they are joining the message group created by the first player. RING at pp. 89.

CLAIM 6

The method of claim 1 wherein said network is Internet and said server communicates with said plurality of host computers using a session layer protocol.

RING discloses the method of claim 1 wherein the network is the Internet (*e.g.*, a wide-area network”) and the server communicates with a plurality of host computers (*e.g.*, “client workstations”) using a session layer protocol because RING discloses UDP/IP and application layer protocols that include session layer functionality. RING at Abstract, pp. 85, 86, 87, 89, 90, 91 and Fig. 11. The wide-area network disclosed by RING includes the Internet, because RING uses the UDP/IP protocol, which is a member of the Internet Protocol Suite, the set of network protocols used for the Internet. RING at 89, 85, Fig. 11.

VI. CONCLUSION

The prior art documents presented in the above Request were either not previously considered by the Office during prosecution of the ‘523 patent, or are now being presented in a new light pursuant to MPEP § 2242 (II). None of the six claims of the ‘523 patent are patentable over the prior art documents cited herein alone or in combination. While Requester has put forth various combinations of the prior art, numerous other combinations are possible. The prior art documents teach the subject matter of the ‘523 patent in a manner such that substantial new questions of patentability for all six claims of the ‘523 patent are raised by this Request.

In view of the foregoing, it is respectfully submitted that substantial new questions of patentability of Claims 1-6 of Patent No. 5,822,523 are raised by this Request. Accordingly, the Office is requested to grant this Request and to initiate reexamination with special dispatch. Claims 1-6 should be reexamined, rejected under 35 U.S.C. §§ 102-103, and canceled pursuant to this Request.

As an aid to the application of the presented prior art to claims of the ‘523 patent, corresponding claim charts are attached hereto.

Enclosed is a credit card authorization to cover the fee for reexamination. If this authorization is missing or defective, please charge the fee to the Novak Druce Deposit Account No. 14-1437.

NOVAK DRUCE + QUIGG, LLP
1000 Louisiana St.
53rd Floor
Houston, Texas 77002
P: 713-571-3400
F: 713-456-2836

Respectfully submitted,

/ Tracy W. Druce /
Novak Druce & Quigg, LLP
Tracy W. Druce
Reg. No. 35,493
James P. Murphy
Reg. No. 55,474
Lissi Mojica-Marquis
Reg. No. 63,421

Electronic Acknowledgement Receipt

EFS ID:	7810753
Application Number:	90011033
International Application Number:	
Confirmation Number:	1686
Title of Invention:	SERVER-GROUP MESSAGING SYSTEM FOR INTERACTIVE APPLICATIONS
First Named Inventor/Applicant Name:	Daniel J. Samuel
Correspondence Address:	- - - - - - -
Filer:	Tracy Wesley Druce/Kevin Greenleaf
Filer Authorized By:	Tracy Wesley Druce
Attorney Docket Number:	18830.0003
Receipt Date:	14-JUN-2010
Filing Date:	
Time Stamp:	18:44:32
Application Type:	Reexam (Third Party)

Payment information:

Submitted with Payment	no
------------------------	----

File Listing:

Document Number	Document Description	File Name	File Size(Bytes)/ Message Digest	Multi Part /.zip	Pages (if appl.)
1	Receipt of Corrected Original Ex Parte Request	523_ex_parte_reexam_52pgs.pdf	371450 10e018d7eec6dbcd0c5770099ad06cda1fc2aed5	no	52
Warnings:					
Information:					
Total Files Size (in bytes):			371450		
<p>This Acknowledgement Receipt evidences receipt on the noted date by the USPTO of the indicated documents, characterized by the applicant, and including page counts, where applicable. It serves as evidence of receipt similar to a Post Card, as described in MPEP 503.</p> <p><u>New Applications Under 35 U.S.C. 111</u> If a new application is being filed and the application includes the necessary components for a filing date (see 37 CFR 1.53(b)-(d) and MPEP 506), a Filing Receipt (37 CFR 1.54) will be issued in due course and the date shown on this Acknowledgement Receipt will establish the filing date of the application.</p> <p><u>National Stage of an International Application under 35 U.S.C. 371</u> If a timely submission to enter the national stage of an international application is compliant with the conditions of 35 U.S.C. 371 and other applicable requirements a Form PCT/DO/EO/903 indicating acceptance of the application as a national stage submission under 35 U.S.C. 371 will be issued in addition to the Filing Receipt, in due course.</p> <p><u>New International Application Filed with the USPTO as a Receiving Office</u> If a new international application is being filed and the international application includes the necessary components for an international filing date (see PCT Article 11 and MPEP 1810), a Notification of the International Application Number and of the International Filing Date (Form PCT/RO/105) will be issued in due course, subject to prescriptions concerning national security, and the date shown on this Acknowledgement Receipt will establish the international filing date of the application.</p>					

Application Number 	Application/Control No. 90/011,033	Applicant(s)/Patent Under Reexamination 5,822,523
	Examiner ***	Art Unit 3992

Index of Claims 	Application/Control No. 90011033	Applicant(s)/Patent Under Reexamination 5,822,523
	Examiner ***	Art Unit 3992

✓	- Rejected
=	Allowed

-	Cancelled
÷	Restricted

N	Non-Elected
I	Interference

A	Appeal
O	Objected

<input type="checkbox"/> Claims renumbered in the same order as presented by applicant		<input type="checkbox"/> CPA	<input type="checkbox"/> T.D.	<input type="checkbox"/> R.1.47					
CLAIM		DATE							
Final	Original								
	1								
	2								
	3								
	4								
	5								
	6								

Issue Classification 	Application/Control No. 90011033	Applicant(s)/Patent Under Reexamination 5,822,523
	Examiner ***	Art Unit 3992

ORIGINAL						INTERNATIONAL CLASSIFICATION											
CLASS			SUBCLASS			CLAIMED						NON-CLAIMED					
395			200.170														
CROSS REFERENCE(S)																	
CLASS	SUBCLASS (ONE SUBCLASS PER BLOCK)																

<input type="checkbox"/> Claims renumbered in the same order as presented by applicant <input type="checkbox"/> CPA <input type="checkbox"/> T.D. <input type="checkbox"/> R.1.47															
Final	Original	Final	Original	Final	Original	Final	Original	Final	Original	Final	Original	Final	Original	Final	Original

(Assistant Examiner) _____ (Date) _____		Total Claims Allowed:	
(Primary Examiner) _____ (Date) _____		O.G. Print Claim(s)	O.G. Print Figure

Reexamination 	Application/Control No. 90011033	Applicant(s)/Patent Under Reexamination 5,822,523
	Certificate Date	Certificate Number

Requester Correspondence Address: **Patent Owner** **Third Party**

NOVAK DRUCE & QUIGG, LLP
 (NDQ REEXAMINATION GROUP)
 1000 LOUISIANA STREET, FIFTY-THIRD FLOOR
 HOUSTON, TX 77002

LITIGATION REVIEW <input type="checkbox"/>	(examiner initials)	(date)
Case Name	Director Initials	

COPENDING OFFICE PROCEEDINGS	
TYPE OF PROCEEDING	NUMBER

--	--

Search Notes 	Application/Control No. 90011033	Applicant(s)/Patent Under Reexamination 5,822,523
	Examiner ***	Art Unit 3992

SEARCHED			
Class	Subclass	Date	Examiner
395	200.170		

SEARCH NOTES		
Search Notes	Date	Examiner

INTERFERENCE SEARCH			
Class	Subclass	Date	Examiner

--	--



UNITED STATES PATENT AND TRADEMARK OFFICE

UNITED STATES DEPARTMENT OF COMMERCE
 United States Patent and Trademark Office
 Address: COMMISSIONER FOR PATENTS
 P.O. Box 1450
 Alexandria, Virginia 22313-1450
 www.uspto.gov



Bib Data Sheet

CONFIRMATION NO. 1686

SERIAL NUMBER 90/011,033	FILING OR 371(c) DATE 06/14/2010 RULE	CLASS 395	GROUP ART UNIT 3992	ATTORNEY DOCKET NO. 18830.0003
------------------------------------	---	---------------------	-------------------------------	--

APPLICANTS
 5,822,523, Residence Not Provided;
 PALTALK HOLDINGS, INC. (OWNER), NEW YORK, NY;
 NOVAK DRUCE & QUIGG LLP (3RD PTY. REQ.), HOUSTON, TX;
 NOVAK DRUCE & QUIGG, LLP, HOUSTON, TX

**** CONTINUING DATA *******
 This application is a REX of 08/595,323 02/01/1996 PAT 5,822,523

**** FOREIGN APPLICATIONS *******

Foreign Priority claimed <input type="checkbox"/> yes <input type="checkbox"/> no	STATE OR COUNTRY	SHEETS DRAWING	TOTAL CLAIMS 6	INDEPENDENT CLAIMS 1
35 USC 119 (a-d) conditions met <input type="checkbox"/> yes <input type="checkbox"/> no <input type="checkbox"/> Met after Allowance				
Verified and Acknowledged	Examiner's Signature	Initials		

ADDRESS
 26137

TITLE
 SERVER-GROUP MESSAGING SYSTEM FOR INTERACTIVE APPLICATIONS

FILING FEE RECEIVED 2520	FEES: Authority has been given in Paper No. _____ to charge/credit DEPOSIT ACCOUNT No. _____ for following:	<input type="checkbox"/> All Fees <input type="checkbox"/> 1.16 Fees (Filing) <input type="checkbox"/> 1.17 Fees (Processing Ext. of time) <input type="checkbox"/> 1.18 Fees (Issue) <input type="checkbox"/> Other _____ <input type="checkbox"/> Credit
------------------------------------	---	---

ARTIFACT SHEET

Enter artifact number below. Artifact number is application number + artifact type code (see list below) + sequential letter (A, B, C ...). The first artifact folder for an artifact type receives the letter A, the second B, etc.. Examples: 59123456PA, 59123456PB, 59123456ZA, 59123456ZB

C 90/011,033 PA

Indicate quantity of a single type of artifact received but not scanned. Create individual artifact folder/box and artifact number for each Artifact Type.

 2

CD(s) containing:

computer program listing

Doc Code: Computer

pages of specification

and/or sequence listing

and/or table

Doc Code: Artifact

content unspecified or combined

Doc Code: Artifact

Artifact Type Code: P

Artifact Type Code: S

Artifact Type Code: U

Stapled Set(s) Color Documents or B/W Photographs

Doc Code: Artifact Artifact Type Code: C

Microfilm(s)

Doc Code: Artifact Artifact Type Code: F

Video tape(s)

Doc Code: Artifact Artifact Type Code: V

Model(s)

Doc Code: Artifact Artifact Type Code: M

Bound Document(s)

Doc Code: Artifact Artifact Type Code: B

Confidential Information Disclosure Statement or Other Documents marked Proprietary, Trade Secrets, Subject to Protective Order, Material Submitted under MPEP 724.02, etc.

Doc Code: Artifact Artifact Type Code X

Other, description: _____

Doc Code: Artifact Artifact Type Code: Z

March 8, 2004

Patent Assignment Abstract of Title

Total Assignments: 9

Application #: 08595323 Filing Dt: 02/01/1996 Patent #: 5822523 Issue Dt: 10/13/1998
PCT #: NONE Publication #: NONE Pub Dt:
Inventors: DANIEL J. SAMUEL, MARC P. KWIATKOWSKI, JEFFREY J. ROTHSCHILD
Title: SERVER-GROUP MESSAGING SYSTEM FOR INTERACTIVE APPLICATIONS

Assignment: 1

Reel/Frame: 007861 / 0413 Received: 04/03/1996 Recorded: 02/01/1996 Mailed: 06/19/1996 Pages: 4

Conveyance: ASSIGNMENT OF ASSIGNORS INTEREST (SEE DOCUMENT FOR DETAILS).

Assignors: SAMUEL, DANIEL JOSEPH Exec Dt: 01/30/1996
KWIATKOWSKI, MARC PETER Exec Dt: 01/30/1996
ROTHSCHILD, JEFFREY JACKIEL Exec Dt: 01/30/1996

Assignee: MPATH INTERACTIVE, INC.
10455-A BANDLEY DRIVE
CUPERTINO, CALIFORNIA 95014

Correspondent: WILSON, SONSINI, GOODRICH & ROSATI
H. C. CHAN
650 PAGE MILL ROAD
PALO ALTO, CA 94304-1050

Assignment: 2

Reel/Frame: 009360 / 0653 Received: 08/10/1998 Recorded: 08/10/1998 Mailed: 12/11/1998 Pages: 11

Conveyance: SECURITY AGREEMENT

Assignor: MPATH INTERACTIVE, INC. Exec Dt: 07/29/1998

Assignee: GREYROCK BUSINESS CREDIT, A DIVISION OF NATIONSCREDIT COMMERCIAL CORPORATION
10880 WILSHIRE BOULEVARD, SUITE 950
LOS ANGELES, CALIFORNIA 90024

Correspondent: LEVY, SMALL & LALLAS
ATTN: KATHYRN GAMBINO
815 MORAGA DRIVE
LOS ANGELES, CA 90049-1633

Assignment: 3

Reel/Frame: 011035 / 0740 Received: 09/07/2000 Recorded: 08/09/2000 Mailed: 12/05/2000 Pages: 7

Conveyance: CHANGE OF NAME (SEE DOCUMENT FOR DETAILS).

Assignor: MPATH INTERACTIVE, INC. Exec Dt: 01/07/2000

Assignee: HEARME
665 CLYDE AVENUE.
MOUNTAIN VIEW, CALIFORNIA 94043

Correspondent: STERNE, KESSLER, GOLDSTEIN & FOX PLLC
MICHAEL B. RAY
1100 NEW YORK AVE., N.W.
SUITE 600
WASHINGTON, DC 20005-3934

Assignment: 4

Reel/Frame: 011164 / 0198 Received: 10/23/2000 Recorded: 03/15/2000 Mailed: 12/13/2000 Pages: 3

Conveyance: RELEASE OF SECURITY INTEREST

Assignor: GREYROCK BUSINESS CREDIT Exec Dt: 03/01/2000

Assignee: MPATH INTERACTIVE, INC.
665 CLYDE AVENUE
MOUNTAIN VIEW, CALIFORNIA 94043

Correspondent: STERNE, KESSLER, GOLDSTEIN & FOX P.L.L.C
MICHAEL B. RAY
1100 NEW YORK AVE., N.W.

SUITE 600
WASHINGTON, D.C. 20005-3934

Assignment: 5

Reel/Frame: 012598 / 0506 **Received:** 02/27/2002 **Recorded:** 02/11/2002 **Mailed:** 04/19/2002 **Pages:** 2

Conveyance: ASSIGNMENT OF ASSIGNORS INTEREST (SEE DOCUMENT FOR DETAILS).

Assignor: HEARME, INC. **Exec Dt:** 12/19/2001

Assignee: PALTALK HOLDINGS, INC.
213 WEST 35TH STREET, 13TH FLOOR
NEW YORK, NEW YORK 10001

Correspondent: FENWICK & WEST LLP
RAJIV P. PATEL, ESQ.
TWO PALO ALTO SQUARE
PALO ALTO, CA 94306

Assignment: 6

Reel/Frame: 015732 / 0121 **Received:** 09/01/2004 **Recorded:** 08/27/2004 **Mailed:** 03/05/2005 **Pages:** 37

Conveyance: SECURITY AGREEMENT

Assignor: LEAP WIRELESS INTERNATIONAL, INC. **Exec Dt:** 08/16/2004

Assignee: WELLS FARGO BANK, N.A., AS COLLATERAL AGENT
SIXTH AND MARQUETTE
MAC N9303-120
MINNEAPOLIS, MINNESOTA 55479

Correspondent: LATHAM & WATKINS
RHONDA DELEON
650 TOWN CENTER DRIVE
SUITE 2000
COSTA MESA, A 92626

Assignment: 7

Reel/Frame: 016290 / 0577 **Received:** 02/28/2005 **Recorded:** 02/17/2005 **Mailed:** 07/22/2005 **Pages:** 12

Conveyance: SECURITY INTEREST (SEE DOCUMENT FOR DETAILS).

Assignors: <u>CRICKET COMMUNICATIONS, INC.</u>	Exec Dt: 01/10/2005
<u>LEAP WIRELESS INTERNATIONAL, INC.</u>	Exec Dt: 01/10/2005
<u>BACKWIRE.COM, INC.</u>	Exec Dt: 01/10/2005
<u>TELEPHONE ENTERTAINMENT NETWORK, INC.</u>	Exec Dt: 01/10/2005
<u>CHASETEL LICENSEE CORP.</u>	Exec Dt: 01/10/2005
<u>CRICKET LICENSEE (ALBANY), INC.</u>	Exec Dt: 01/10/2005
<u>CRICKET LICENSEE (COLUMBUS), INC.</u>	Exec Dt: 01/10/2005
<u>CRICKET LICENSEE (DENVER), INC.</u>	Exec Dt: 01/10/2005
<u>CRICKET LICENSEE (LAKELAND), INC.</u>	Exec Dt: 01/10/2005
<u>CRICKET LICENSEE (MACON), INC.</u>	Exec Dt: 01/10/2005
<u>CRICKET LICENSEE (NORTH CAROLINA), INC.</u>	Exec Dt: 01/10/2005
<u>CRICKET LICENSEE (PITTSBURGH), INC.</u>	Exec Dt: 01/10/2005
<u>CRICKET LICENSEE (RECAUTION), INC.</u>	Exec Dt: 01/10/2005
<u>CRICKET LICENSEE I, INC.</u>	Exec Dt: 01/10/2005
<u>CRICKET LICENSEE II, INC.</u>	Exec Dt: 01/10/2005
<u>CRICKET LICENSEE III, INC.</u>	Exec Dt: 01/10/2005
<u>CRICKET LICENSEE IV, INC.</u>	Exec Dt: 01/10/2005
<u>CRICKET LICENSEE V, INC.</u>	Exec Dt: 01/10/2005
<u>CRICKET LICENSEE VI, INC.</u>	Exec Dt: 01/10/2005
<u>CRICKET LICENSEE VII, INC.</u>	Exec Dt: 01/10/2005
<u>CRICKET LICENSEE VIII, INC.</u>	Exec Dt: 01/10/2005
<u>CRICKET LICENSEE IX, INC.</u>	Exec Dt: 01/10/2005

<u>CRICKET LICENSEE X, INC.</u>	Exec Dt: 01/10/2005
<u>CRICKET LICENSEE XII, INC.</u>	Exec Dt: 01/10/2005
<u>CRICKET LICENSEE XIII, INC.</u>	Exec Dt: 01/10/2005
<u>CRICKET LICENSEE XIV, INC.</u>	Exec Dt: 01/10/2005
<u>CRICKET LICENSEE XV, INC.</u>	Exec Dt: 01/10/2005
<u>CRICKET LICENSEE XVI, INC.</u>	Exec Dt: 01/10/2005
<u>CRICKET LICENSEE XVII, INC.</u>	Exec Dt: 01/10/2005
<u>CRICKET LICENSEE XVIII, INC.</u>	Exec Dt: 01/10/2005
<u>CRICKET LICENSEE XIX, INC.</u>	Exec Dt: 01/10/2005
<u>CRICKET LICENSEE XX, INC.</u>	Exec Dt: 01/10/2005
<u>CRICKET HOLDINGS DAYTON, INC.</u>	Exec Dt: 01/10/2005
<u>MCG PCS LICENSEE CORPORATION, INC.</u>	Exec Dt: 01/10/2005
<u>CHASETEL REAL ESTATE HOLDING COMPANY, INC.</u>	Exec Dt: 01/10/2005
<u>CRICKET ALABAMA PROPERTY COMPANY</u>	Exec Dt: 01/10/2005
<u>CRICKET ARIZONA PROPERTY COMPANY</u>	Exec Dt: 01/10/2005
<u>CRICKET ARKANSAS PROPERTY COMPANY</u>	Exec Dt: 01/10/2005
<u>CRICKET CALIFORNIA PROPERTY COMPANY</u>	Exec Dt: 01/10/2005
<u>CRICKET COLORADO PROPERTY COMPANY</u>	Exec Dt: 01/10/2005
<u>CRICKET FLORIDA PROPERTY COMPANY</u>	Exec Dt: 01/10/2005
<u>CRICKET GEORGIA PROPERTY COMPANY, INC.</u>	Exec Dt: 01/10/2005
<u>CRICKET IDAHO PROPERTY COMPANY</u>	Exec Dt: 01/10/2005
<u>CRICKET ILLINOIS PROPERTY COMPANY</u>	Exec Dt: 01/10/2005
<u>CRICKET INDIANA PROPERTY COMPANY</u>	Exec Dt: 01/10/2005
<u>CRICKET KANSAS PROPERTY COMPANY</u>	Exec Dt: 01/10/2005
<u>CRICKET KENTUCKY PROPERTY COMPANY</u>	Exec Dt: 01/10/2005
<u>CRICKET MICHIGAN PROPERTY COMPANY</u>	Exec Dt: 01/10/2005
<u>CRICKET MINNESOTA PROPERTY COMPANY</u>	Exec Dt: 01/10/2005
<u>CRICKET MISSISSIPPI PROPERTY COMPANY</u>	Exec Dt: 01/10/2005
<u>CRICKET NEBRASKA PROPERTY COMPANY</u>	Exec Dt: 01/10/2005
<u>CRICKET NEVADA PROPERTY COMPANY</u>	Exec Dt: 01/10/2005
<u>CRICKET NEW MEXICO PROPERTY COMPANY</u>	Exec Dt: 01/10/2005
<u>CRICKET NEW YORK PROPERTY COMPANY, INC.</u>	Exec Dt: 01/10/2005
<u>CRICKET NORTH CAROLINA PROPERTY COMPANY</u>	Exec Dt: 01/10/2005
<u>CRICKET OHIO PROPERTY COMPANY</u>	Exec Dt: 01/10/2005
<u>CRICKET OKLAHOMA PROPERTY COMPANY</u>	Exec Dt: 01/10/2005
<u>CRICKET OREGON PROPERTY COMPANY</u>	Exec Dt: 01/10/2005
<u>CRICKET PENNSYLVANIA PROPERTY COMPANY</u>	Exec Dt: 01/10/2005
<u>CRICKET TEXAS PROPERTY COMPANY</u>	Exec Dt: 01/10/2005
<u>CRICKET UTAH PROPERTY COMPANY</u>	Exec Dt: 01/10/2005
<u>CRICKET WASHINGTON PROPERTY COMPANY</u>	Exec Dt: 01/10/2005
<u>CRICKET WISCONSIN PROPERTY COMPANY</u>	Exec Dt: 01/10/2005
<u>LEAP PCS MEXICO, INC.</u>	Exec Dt: 01/10/2005

Assignee: BANK OF AMERICA N.A.
100 NORTH TYRON STREET
CHARLOTTE, NORTH CAROLINA 28255

Correspondent: INTELLECTUAL PROPERTY DOCKETING
SHEARMAN & STERLING LLP
599 LEXINGTON AVENUE
NEW YORK, NY 10022

Assignment: 8**Reel/Frame:** 022793 / 0850 **Received:** 06/09/2009 **Recorded:** 06/09/2009 **Mailed:** 06/11/2009 **Pages:** 13**Conveyance:** SECURITY AGREEMENT**Assignors:** CRICKET COMMUNICATIONS, INC.**Exec Dt:** 06/05/2009LEAP WIRELESS INTERNATIONAL, INC.**Exec Dt:** 06/05/2009CRICKET LICENSEE (REACTION), LLC**Exec Dt:** 06/05/2009CRICKET LICENSEE I, LLC**Exec Dt:** 06/05/2009CRICKET LICENSEE 2007, LLC**Exec Dt:** 06/05/2009**Assignee:** WILMINGTON TRUST FSB1100 NORTH MARKET ST. C/O WILMINGTON TRUST COMPANY
ATTN.: CORPORATE CAPITAL MARKETS
WILMINGTON, DELAWARE 19890**Correspondent:** JORDAN ALTMAN599 LEXINGTON AVENUE
SHEARMAN & STERLING LLP - IP DOCKETING
NEW YORK, NY 10022**Assignment: 9****Reel/Frame:** 022804 / 0745 **Received:** 06/09/2009 **Recorded:** 06/09/2009 **Mailed:** 06/11/2009 **Pages:** 23**Conveyance:** RELEASE BY SECURED PARTY (SEE DOCUMENT FOR DETAILS).**Assignor:** BANK OF AMERICA, N.A.**Exec Dt:** 06/05/2009**Assignees:** CRICKET COMMUNICATIONS, INC.1307 PACIFIC CENTER COURT
SAN DIEGO, CALIFORNIA 92121LEAP WIRELESS INTERNATIONAL, INC.1307 PACIFIC CENTER COURT
SAN DIEGO, CALIFORNIA 92121TELEPHONE ENTERTAINMENT NETWORK, INC.1307 PACIFIC CENTER COURT
SAN DIEGO, CALIFORNIA 92121CHASETEL LICENSEE CORP.1307 PACIFIC CENTER COURT
SAN DIEGO, CALIFORNIA 92121CRICKET LICENSEE (ALBANY), INC.1307 PACIFIC CENTER COURT
SAN DIEGO, CALIFORNIA 92121CRICKET LICENSEE (COLUMBUS), INC.1307 PACIFIC CENTER COURT
SAN DIEGO, CALIFORNIA 92121CRICKET LICENSEE (DENVER) INC.1307 PACIFIC CENTER COURT
SAN DIEGO, CALIFORNIA 92121CRICKET LICENSSE (LAKELAND) INC.1307 PACIFIC CENTER COURT
SAN DIEGO, CALIFORNIA 92121CRICKET LICENSEE (MACON), INC.1307 PACIFIC CENTER COURT
SAN DIEGO, CALIFORNIA 92121CRICKET LICENSEE (NORTH CAROLINA) INC.1307 PACIFIC CENTER COURT
SAN DIEGO, CALIFORNIA 92121CRICKET LICENSEE (PITTSBURGH) INC.1307 PACIFIC CENTER COURT
SAN DIEGO, CALIFORNIA 92121CRICKET LICENSEE (REACTION), INC.

1307 PACIFIC CENTER COURT
SAN DIEGO, CALIFORNIA 92121
CRICKET LICENSEE I, INC.
1307 PACIFIC CENTER COURT
SAN DIEGO, CALIFORNIA 92121
CRICKET LICENSEE II, INC.
1307 PACIFIC CENTER COURT
SAN DIEGO, CALIFORNIA 92121
CRICKET LICENSEE III, INC.
1307 PACIFIC CENTER COURT
SAN DIEGO, CALIFORNIA 92121
CRICKET LICENSEE IV, INC.
1307 PACIFIC CENTER COURT
SAN DIEGO, CALIFORNIA 92121
CRICKET LICENSEE V, INC.
1307 PACIFIC CENTER COURT
SAN DIEGO, CALIFORNIA 92121
CRICKET LICENSEE VI, INC.
1307 PACIFIC CENTER COURT
SAN DIEGO, CALIFORNIA 92121
CRICKET LICENSEE VII, INC.
1307 PACIFIC CENTER COURT
SAN DIEGO, CALIFORNIA 92121
CRICKET LICENSEE VIII, INC.
1307 PACIFIC CENTER COURT
SAN DIEGO, CALIFORNIA 92121
CRICKET LICENSEE IX, INC.
1307 PACIFIC CENTER COURT
SAN DIEGO, CALIFORNIA 92121
CRICKET LICENSEE X, INC.
1307 PACIFIC CENTER COURT
SAN DIEGO, CALIFORNIA 92121
CRICKET LICENSEE XI, INC.
1307 PACIFIC CENTER COURT
SAN DIEGO, CALIFORNIA 92121
CRICKET LICENSEE XII, INC.
1307 PACIFIC CENTER COURT
SAN DIEGO, CALIFORNIA 92121
CRICKET LICENSEE XIII, INC.
1307 PACIFIC CENTER COURT
SAN DIEGO, CALIFORNIA 92121
CRICKET LICENSEE XIV, INC.
1307 PACIFIC CENTER COURT
SAN DIEGO, CALIFORNIA 92121
CRICKET LICENSEE XV, INC.
1307 PACIFIC CENTER COURT
SAN DIEGO, CALIFORNIA 92121
CRICKET LICENSEE XVI, INC.
1307 PACIFIC CENTER COURT
SAN DIEGO, CALIFORNIA 92121
CRICKET LICENSEE XVII, INC.
1307 PACIFIC CENTER COURT
SAN DIEGO, CALIFORNIA 92121
CRICKET LICENSEE XVIII, INC.
1307 PACIFIC CENTER COURT

SAN DIEGO, CALIFORNIA 92121
CRICKET LICENSEE XIX, INC.
1307 PACIFIC CENTER COURT
SAN DIEGO, CALIFORNIA 92121
CRICKET LICENSEE XX, INC.
1307 PACIFIC CENTER COURT
SAN DIEGO, CALIFORNIA 92121
CRICKET HOLDINGS DAYTON, INC.
1307 PACIFIC CENTER COURT
SAN DIEGO, CALIFORNIA 92121
MCG PCS LICENSEE CORPORATION, INC.
1307 PACIFIC CENTER COURT
SAN DIEGO, CALIFORNIA 92121
CHASETEL REAL ESTATE HOLDING COMPANY, INC.
1307 PACIFIC CENTER COURT
SAN DIEGO, CALIFORNIA 92121
BACKWIRE.COM, INC.
1307 PACIFIC CENTER COURT
SAN DIEGO, CALIFORNIA 92121
CRICKET ALABAMA PROPERTY COMPANY
1307 PACIFIC CENTER COURT
SAN DIEGO, CALIFORNIA 92121
CRICKET ARIZONA PROPERTY COMPANY
1307 PACIFIC CENTER COURT
SAN DIEGO, CALIFORNIA 92121
CRICKET ARKANSAS PROPERTY COMPANY
1307 PACIFIC CENTER COURT
SAN DIEGO, CALIFORNIA 92121
CRICKET CALIFORNIA PROPERTY COMPANY
1307 PACIFIC CENTER COURT
SAN DIEGO, CALIFORNIA 92121
CRICKET COLORADO PROPERTY COMPANY
1307 PACIFIC CENTER COURT
SAN DIEGO, CALIFORNIA 92121
CRICKET FLORIDA PROPERTY COMPANY
1307 PACIFIC CENTER COURT
SAN DIEGO, CALIFORNIA 92121
CRICKET GEORGIA PROPERTY COMPANY, INC.
1307 PACIFIC CENTER COURT
SAN DIEGO, CALIFORNIA 92121
CRICKET IDAHO PROPERTY COMPANY
1307 PACIFIC CENTER COURT
SAN DIEGO, CALIFORNIA 92121
CRICKET ILLINOIS PROPERTY COMPANY
1307 PACIFIC CENTER COURT
SAN DIEGO, CALIFORNIA 92121
CRICKET INDIANA PROPERTY COMPANY
1307 PACIFIC CENTER COURT
SAN DIEGO, CALIFORNIA 92121
CRICKET KANSAS PROPERTY COMPANY
1307 PACIFIC CENTER COURT
SAN DIEGO, CALIFORNIA 92121
CRICKET KENTUCKY PROPERTY COMPANY
1307 PACIFIC CENTER COURT
SAN DIEGO, CALIFORNIA 92121

CRICKET MICHIGAN PROPERTY COMPANY
1307 PACIFIC CENTER COURT
SAN DIEGO, CALIFORNIA 92121

CRICKET MINNESOTA PROPERTY COMPANY
1307 PACIFIC CENTER COURT
SAN DIEGO, CALIFORNIA 92121

CRICKET MISSISSIPPI PROPERTY COMPANY
1307 PACIFIC CENTER COURT
SAN DIEGO, CALIFORNIA 92121

CRICKET NEBRASKA PROPERTY COMPANY
1307 PACIFIC CENTER COURT
SAN DIEGO, CALIFORNIA 92121

CRICKET NEVADA PROPERTY COMPANY
1307 PACIFIC CENTER COURT
SAN DIEGO, CALIFORNIA 92121

CRICKET NEW MEXICO PROPERTY COMPANY
1307 PACIFIC CENTER COURT
SAN DIEGO, CALIFORNIA 92121

CRICKET NEW YORK PROPERTY COMPANY, INC.
1307 PACIFIC CENTER COURT
SAN DIEGO, CALIFORNIA 92121

CRICKET NORTH CAROLINA PROPERTY COMPANY
1307 PACIFIC CENTER COURT
SAN DIEGO, CALIFORNIA 92121

CRICKET OHIO PROPERTY COMPANY
1307 PACIFIC CENTER COURT
SAN DIEGO, CALIFORNIA 92121

CRICKET OKLAHOMA PROPERTY COMPANY
1307 PACIFIC CENTER COURT
SAN DIEGO, CALIFORNIA 92121

CRICKET OREGON PROPERTY COMPANY
1307 PACIFIC CENTER COURT
SAN DIEGO, CALIFORNIA 92121

CRICKET PENNSYLVANIA PROPERTY COMPANY
1307 PACIFIC CENTER COURT
SAN DIEGO, CALIFORNIA 92121

CRICKET TEXAS PROPERTY COMPANY
1307 PACIFIC CENTER COURT
SAN DIEGO, CALIFORNIA 92121

CRICKET UTAH PROPERTY COMPANY
1307 PACIFIC CENTER COURT
SAN DIEGO, CALIFORNIA 92121

CRICKET WASHINGTON PROPERTY COMPANY
1307 PACIFIC CENTER COURT
SAN DIEGO, CALIFORNIA 92121

CRICKET WISCONSIN PROPERTY COMPANY
1307 PACIFIC CENTER COURT
SAN DIEGO, CALIFORNIA 92121

LEAP PCS MEXICO, INC.
1307 PACIFIC CENTER COURT
SAN DIEGO, CALIFORNIA 92121

Correspondent: JORDAN ALTMAN
599 LEXINGTON AVENUE
SHEARMAN & STERLING LLP - IP DOCKETING
NEW YORK, NY 10022

If you have any comments or questions concerning the data displayed, contact PRD / Assignments at 571-272-3350.
Web interface last modified: October 18, 2008 v.2.0.1



UNITED STATES PATENT AND TRADEMARK OFFICE

UNITED STATES DEPARTMENT OF COMMERCE
United States Patent and Trademark Office
Address: COMMISSIONER FOR PATENTS
P.O. Box 1450
Alexandria, Virginia 22313-1450
www.uspto.gov

REEEXAM CONTROL NUMBER	FILING OR 371 (c) DATE	PATENT NUMBER
90/011,033	06/14/2010	5822523

NOVAK DRUCE & QUIGG, LLP
(NDQ REEXAMINATION GROUP)
1000 LOUISIANA STREET, FIFTY-THIRD FLOOR
HOUSTON, TX 77002

CONFIRMATION NO. 1686
REEXAMINATION REQUEST
NOTICE



Date Mailed: 06/28/2010

NOTICE OF REEXAMINATION REQUEST FILING DATE

(Third Party Requester)

Requester is hereby notified that the filing date of the request for reexamination is 06/14/2010, the date that the filing requirements of 37 CFR § 1.510 were received.

A decision on the request for reexamination will be mailed within three months from the filing date of the request for reexamination. (See 37 CFR 1.515(a)).

A copy of the Notice is being sent to the person identified by the requester as the patent owner. Further patent owner correspondence will be the latest attorney or agent of record in the patent file. (See 37 CFR 1.33). Any paper filed should include a reference to the present request for reexamination (by Reexamination Control Number).

cc: Patent Owner
26137
PATENT DEPARTMENT
SKADDEN, ARPS, SLATE, MEAGHER & FLOM LLP
FOUR TIMES SQUARE
NEW YORK, NY 10036

/jawhitfield/

Legal Instruments Examiner
Central Reexamination Unit 571-272-7705; FAX No. 571-273-9900



UNITED STATES PATENT AND TRADEMARK OFFICE

UNITED STATES DEPARTMENT OF COMMERCE
United States Patent and Trademark Office
Address: COMMISSIONER FOR PATENTS
P.O. Box 1450
Alexandria, Virginia 22313-1450
www.uspto.gov

REEXAM CONTROL NUMBER	FILING OR 371 (c) DATE	PATENT NUMBER
90/011,033	06/14/2010	5822523

CONFIRMATION NO. 1686
REEXAM ASSIGNMENT NOTICE

26137
PATENT DEPARTMENT
SKADDEN, ARPS, SLATE, MEAGHER & FLOM LLP
FOUR TIMES SQUARE
NEW YORK, NY 10036



Date Mailed: 06/28/2010

NOTICE OF ASSIGNMENT OF REEXAMINATION REQUEST

The above-identified request for reexamination has been assigned to Art Unit 3992. All future correspondence to the proceeding should be identified by the control number listed above and directed to the assigned Art Unit.

A copy of this Notice is being sent to the latest attorney or agent of record in the patent file or to all owners of record. (See 37 CFR 1.33(c)). If the addressee is not, or does not represent, the current owner, he or she is required to forward all communications regarding this proceeding to the current owner(s). An attorney or agent receiving this communication who does not represent the current owner(s) may wish to seek to withdraw pursuant to 37 CFR 1.36 in order to avoid receiving future communications. If the address of the current owner(s) is unknown, this communication should be returned within the request to withdraw pursuant to Section 1.36.

cc: Third Party Requester(if any)
NOVAK DRUCE & QUIGG, LLP
(NDQ REEXAMINATION GROUP)
1000 LOUISIANA STREET, FIFTY-THIRD FLOOR
HOUSTON, TX 77002

/jawhitfield/

Legal Instruments Examiner
Central Reexamination Unit 571-272-7705; FAX No. 571-273-9900



UNITED STATES PATENT AND TRADEMARK OFFICE

UNITED STATES DEPARTMENT OF COMMERCE
United States Patent and Trademark Office
Address: COMMISSIONER FOR PATENTS
P.O. Box 1450
Alexandria, Virginia 22313-1450
www.uspto.gov

APPLICATION NO.	FILING DATE	FIRST NAMED INVENTOR	ATTORNEY DOCKET NO.	CONFIRMATION NO.
90/011,033	06/14/2010	5,822,523	18830.0003	1686

26137 7590 07/29/2010

PATENT DEPARTMENT
SKADDEN, ARPS, SLATE, MEAGHER & FLOM LLP
FOUR TIMES SQUARE
NEW YORK, NY 10036

EXAMINER

ART UNIT PAPER NUMBER

DATE MAILED: 07/29/2010

Please find below and/or attached an Office communication concerning this application or proceeding.



UNITED STATES PATENT AND TRADEMARK OFFICE

Commissioner for Patents
United States Patent and Trademark Office
P.O. Box 1450
Alexandria, VA 22313-1450
www.uspto.gov

DO NOT USE IN PALM PRINTER

(THIRD PARTY REQUESTER'S CORRESPONDENCE ADDRESS)

NOVAK DRUCE & QUIGG, LLP
(NDQ REEXAMINATION GROUP)
1000 LOUISIANA STREET
FIFTY-THIRD FLOOR
HOUSTON, TX 77002

MAILED

JUL 29 2010

CENTRAL REEXAMINATION UNIT

EX PARTE REEXAMINATION COMMUNICATION TRANSMITTAL FORM

REEXAMINATION CONTROL NO. 90/011,033.

PATENT NO. 5,822,523.

ART UNIT 3992.

Enclosed is a copy of the latest communication from the United States Patent and Trademark Office in the above identified *ex parte* reexamination proceeding (37 CFR 1.550(f)).

Where this copy is supplied after the reply by requester, 37 CFR 1.535, or the time for filing a reply has passed, no submission on behalf of the *ex parte* reexamination requester will be acknowledged or considered (37 CFR 1.550(g)).

Order Granting / Denying Request For Ex Parte Reexamination	Control No. 90/011,033	Patent Under Reexamination 5,822,523	
	Examiner ANDREW L. NALVEN	Art Unit 3992	

--The MAILING DATE of this communication appears on the cover sheet with the correspondence address--

The request for *ex parte* reexamination filed 14 June 2010 has been considered and a determination has been made. An identification of the claims, the references relied upon, and the rationale supporting the determination are attached.

Attachments: a) PTO-892, b) PTO/SB/08, c) Other: Decision on Request

1. The request for *ex parte* reexamination is GRANTED.

RESPONSE TIMES ARE SET AS FOLLOWS:

For Patent Owner's Statement (Optional): **TWO MONTHS** from the mailing date of this communication (37 CFR 1.530 (b)). **EXTENSIONS OF TIME ARE GOVERNED BY 37 CFR 1.550(c).**

For Requester's Reply (optional): **TWO MONTHS** from the **date of service** of any timely filed Patent Owner's Statement (37 CFR 1.535). **NO EXTENSION OF THIS TIME PERIOD IS PERMITTED.** If Patent Owner does not file a timely statement under 37 CFR 1.530(b), then no reply by requester is permitted.

2. The request for *ex parte* reexamination is DENIED.

This decision is not appealable (35 U.S.C. 303(c)). Requester may seek review by petition to the Commissioner under 37 CFR 1.181 within **ONE MONTH** from the mailing date of this communication (37 CFR 1.515(c)). **EXTENSION OF TIME TO FILE SUCH A PETITION UNDER 37 CFR 1.181 ARE AVAILABLE ONLY BY PETITION TO SUSPEND OR WAIVE THE REGULATIONS UNDER 37 CFR 1.183.**

In due course, a refund under 37 CFR 1.26 (c) will be made to requester:

- a) by Treasury check or,
- b) by credit to Deposit Account No. _____, or
- c) by credit to a credit card account, unless otherwise notified (35 U.S.C. 303(c)).

--	--	--

cc:Requester (if third party requester)

DECISION GRANTING EX PARTE REEXAMINATION

A substantial new question of patentability affecting claims 1-6 of United States Patent Number 5,822,523 (hereafter "the '523 patent") is raised by the request for *ex parte* reexamination submitted on June 14, 2010.

Extensions of time under 37 CFR 1.136(a) will not be permitted in these proceedings because the provisions of 37 CFR 1.136 apply only to "an applicant" and not to parties in a reexamination proceeding. Additionally, 35 U.S.C. 305 requires that *ex parte* reexamination proceedings "will be conducted with special dispatch" (37 CFR 1.550(a)). Extensions of time in *ex parte* reexamination proceedings are provided for in 37 CFR 1.550(c).

Notification of Concurrent Proceedings

The patent owner is reminded of the continuing responsibility under 37 CFR 1.985 to apprise the Office of any litigation activity, or other prior or concurrent proceeding, involving the '523 patent throughout the course of this reexamination proceeding. The third party requester is also reminded of the ability to similarly apprise the Office of any such activity or proceeding throughout the course of this reexamination proceeding. See MPEP § 2686 and 2686.04.

PROSECUTION HISTORY

The '523 patent was issued on October 13, 1998 from an application filed February 1, 1996. A first office action was issued on March 20, 1997 that rejected claims 1-16. In response, the Applicant canceled claims 1-6 and 13-16 and argued that the cited prior art did not teach or suggest "aggregating payloads of messages." *'523 Patent Prosecution, Remarks submitted 6/9/1997*. The limitations corresponding to the "aggregating" include:

" aggregating, by said server in a time interval determined in accordance with a predefined criterion, said payload portions of said messages to create an aggregated payload; forming an aggregated message using said aggregated payload" *Claim 1*.

Following the amendments and remarks, on July 9, 1997, a notice of allowance was issued that allowed claims 7-12, now patent claims 1-6.

PROPOSED SUBSTANTIAL NEW QUESTIONS OF PATENTABILITY

Third Party Requester ("Requester") requested reexamination of claims 1-6 of the '523 patent based upon the following prior art patents and publications:

1. Source Code including Server2.5pl4.tar.gz and BRHM-1.3.tar.gz (hereafter "Netrek").
2. RFC 1459 – Internet Relay Chat Protocol by J. Oikarinen, published May 1993 (hereafter "IRC RFC").
3. "Packing Messages as a Tool for Boosting the Performance of Total Ordering Protocols by R. Friedman and published July 7, 1995 (hereafter "Friedman").

4. "An Approach to DIS Scalability" by Van Hook et al and published on September 26-30, 1994 (hereafter "Van Hook").
5. IEEE 1278-1993 IEEE Standard for Information Technology- Protocols for Distributed Interactive Simulation Applications, approved March 18, 1993, and published in 1993 ("DIS")
6. US Patent No. 5,736,982 issued to Suzuki on April 7, 1998 (hereafter "Suzuki") that was not cited in earlier examination. Suzuki qualifies as prior art under §102(e).
7. "RING: A Client-Server System for Multi-User Virtual Environments" by Fukhouser and published April 9-12, 1995 (hereafter "Ring").
8. Andy McFadden, "The History of Netrek", published January 1, 1994 ("McFadden").
9. Michael R. Macedonia, "Exploiting Reality with Multicast Groups", published September 1995 ("Macedonia").

Requestor has alleged a substantial new question of patentability in light of the proposed rejections:

Issue 1 - Claims 1-6 are anticipated by Netrek under 35 U.S.C. §102(b).

Issue 2 - Claims 1-6 are rendered obvious by the combination of Netrek in view of McFadden under 35 U.S.C. 103(a).

Issue 3 - Claims 1, 2, and 4-6 are rendered obvious by the combination of Van Hook in view of DIS under 35 U.S.C. 103(a).

Art Unit: 3992

Issue 4 - Claims 1, 2, and 4-6 are rendered obvious by the combination of IRC RFC in view of Friedman under 35 U.S.C. 103(a).

Issue 5 - Claims 1-6 are rendered obvious by the combination of Ring in view of Netrek under 35 U.S.C. 103(a).

Issue 6 - Claims 1, 2, and 4-6 are rendered obvious by the combination of Ring in view of Van Hook under 35 U.S.C. 103(a).

It is noted that the proposed substantial new questions that are detailed on pages 19-23 do not utilize the Suzuki or the Macedonia reference. Accordingly, the Suzuki and Macedonia references are not discussed herein.

ANALYSIS OF SUBSTANTIAL NEW QUESTIONS OF PATENTABILITY

Summary

Requestor has shown a substantial new question of patentability with regards to claims 1-6 as presented in Issues 1-6.

Analysis

A substantial new question of patentability is raised by a cited patent or printed publication when there is a substantial likelihood that a reasonable examiner would consider the prior art patent or printed publication important in deciding whether or not the claim is patentable. A substantial new question of patentability is not raised by prior art presented in a

reexamination request if the Office has previously considered (in an earlier examination of the patent) the same question of patentability as to a patent claim favorable to the patent owner based on the same prior art patents or printed publications. In re Recreative Technologies, 83 F.3d 1394, 38 USPQ2d 1776 (Fed. Cir. 1996).

Netrek Reference.

The Netrek reference is composed of a client and a server software code that is used to play the Netrek game. The Ahn Declaration attests that both the client and the server code were publicly available on the Internet. Accordingly, Netrek is a printed publication.

Netrek raises a substantial new question of patentability regarding claims 1-6 as presented in Issues 1, 2, and 5. Netrek raises a substantial new question by providing new and non-cumulative teachings that a reasonable examiner would consider important in determining patentability of the claims.

Netrek discloses a server and client code for playing an online based multiplayer game. Netrek provides teachings relevant to the distinguishing features of the '523 patent. For example, Netrek teaches forming an aggregated message using said aggregated payload (*Netrek, Server/ntserv/socket.c at lines 1603-1744 and lines 603-690*). Netrek operates by allowing clients to send messages to the server and the server places the messages into a shared memory (*Server/ntserv/socket.c, lines 1825-2044*). Next, the server will send out a message that aggregates the received client messages to the clients (*Server/ntserv/socket.c, lines 603-90*).

These teachings would be important to a reasonable examiner in deciding patentability because the prosecution history suggests that these features were the reason for allowance of the

claims. Thus, there is a substantial likelihood that a reasonable examiner would consider Netrek important in deciding whether or not the claims are patentable. Accordingly, Netrek raises a substantial new question of patentability as to claims 1-6 that has not been decided in a previous examination.

Requestor proposed Issue 2 as an additional substantial new question based upon Netrek in combination with McFadden. As noted above, Netrek alone raises a substantial new question sufficient to grant reexamination of claims 1-6. Thus, Issue 2 raises a substantial new question in light of the discussion above and a discussion of McFadden is omitted.

Van Hook Reference

Van Hook raises a substantial new question of patentability regarding claims 1, 2, 4, and 6 as presented in Issues 3 and 6. Van Hook raises a substantial new question by providing new and non-cumulative teachings that a reasonable examiner would consider important in determining patentability of the claims.

For example, Van Hook discloses the receiving of packets in the form of PDUs and the bundling of those packets into a bundled packet for transmission (*Van Hook, pages 1-2*). Van Hook discloses a battlefield simulation system that simulates battlefield conditions. Host computers that participate in the simulation send the server state information and the server bundles the state information into a larger packet that is distributed to the host computers.

Van Hook's teaching is relevant to the claimed "aggregating" step and would be important to a reasonable examiner in deciding patentability because the prosecution history suggests that these features were the reason for allowance of the claims. Thus, there is a substantial likelihood that a reasonable examiner would consider Van Hook important in

deciding whether or not the claims are patentable. Accordingly, Van Hook raises a substantial new question of patentability as to claims 1, 2, 4, and 6 that has not been decided in a previous examination.

DIS Reference

DIS does not raise a substantial new question of patentability regarding claims 1, 2, 4, and 6 as presented in Issue 3 because DIS does not provide new and non-cumulative teachings that a reasonable examiner would consider important in determining patentability of the claims. DIS discloses an environment whereby distributed computer systems exchange messages in either a broadcast, unicast, or multicast environment (*DIS, Page 10*). DIS discloses the sending of a message in a multicast procedure to members of a group (*DIS, Pages 10 and 40-41*); however, DIS does not teach the distinguishing feature of aggregating the messages of clients into a single group message. Accordingly, DIS does not independently raise a substantial new question of patentability over claims 1, 2, 4, and 6. However, as noted above, Van Hook alone raises a substantial new question sufficient to grant reexamination of claims 1, 2, 4, and 6. Thus, Issue 3 raises a substantial new question in light of the discussion above.

Ring Reference

RING does not raise a substantial new question of patentability regarding claims 1-6 as presented in Issues 5 and 6 because RING does not provide new and non-cumulative teachings that a reasonable examiner would consider important in determining patentability of the claims. RING discloses a system for supporting real-time visual interaction between users in a shared 3-

Art Unit: 3992

D environment (*RING, Abstract*). RING discloses a client sending a message informing a user of the client's status and the server reporting that status to a group of other users (*RING, Pages 87-91*); however, RING does not teach the distinguishing feature of aggregating the messages of clients into a single group message. Ring's teaching of determining which clients will receive server messages from is not the same as the distinguishing feature of aggregating client messages into a single server message. Accordingly, RING does not independently raise a substantial new question of patentability over claims 1-6. However, as noted above, Van Hook and Netrek alone raises a substantial new question sufficient to grant reexamination of claims 1-6. Thus, Issues 5 and 6 raises a substantial new question in light of the discussion above.

IRC RFC Reference

IRC RFC does not raise a substantial new question of patentability regarding claims 1, 2, 4, and 6 as presented in Issue 4 because IRC RFC does not provide new and non-cumulative teachings that a reasonable examiner would consider important in determining patentability of the claims. IRC RFC discloses a system for providing efficient conferencing between clients in the form of a one-to-many conversation (*IRC RFC, Page 11*). IRC RFC discloses a client sending a message to a server where the server will then distribute the message to other clients who have joined a channel (*IRC RFC, Page 11*); however, IRC RFC does not teach the distinguishing feature of aggregating the messages of clients into a single group message. Accordingly, IRC RFC does not independently raise a substantial new question of patentability over claims 1, 2, 4, and 6.

Art Unit: 3992

Friedman Reference

Friedman raises a substantial new question of patentability regarding claims 1, 2, 4, and 6 as presented in Issues 4. Friedman raises a substantial new question by providing new and non-cumulative teachings that a reasonable examiner would consider important in determining patentability of the claims.

For example, Friedman discloses a system for packing messages in order to improve system performance (*Friedman, Abstract*). Friedman discloses a server packing messages destined for a client into a single packed message utilizing several different protocols (*Friedman, Pages 1 and 5*). For example, messages destined for a particular client are aggregated for a particular period of time and then packed into a single message for transmission (*Friedman, Page 5*). While Friedman does not disclose the aggregation of messages destined for a group, Friedman's aggregation techniques would be important to a reasonable examiner in deciding patentability.

These teachings would be important to a reasonable examiner in deciding patentability because the prosecution history suggests that these features were the reason for allowance of the claims. Thus, there is a substantial likelihood that a reasonable examiner would consider Friedman important in deciding whether or not the claims are patentable. Accordingly, Friedman raises a substantial new question of patentability as to claims 1, 2, 4, and 6 that has not been decided in a previous examination.

CORRESPONDENCE

Art Unit: 3992

All correspondence relating to this ex parte reexamination proceeding should be directed:

By EFS: Registered users may submit via the electronic filing system EFS-Web, at <https://portal.uspto.gov/authenticate/authenticateuserlocalepf.html>.

By Mail to: Mail Stop *Ex Parte* Reexam
Central Reexamination Unit
Commissioner for Patents
United States Patent & Trademark Office
P.O. Box 1450
Alexandria, VA 22313-1450

By FAX to: (571) 273-9900
Central Reexamination Unit

By hand: Customer Service Window
Randolph Building
401 Dulany Street
Alexandria, VA 22314

For EFS-Web transmissions, 37 CFR 1.8(a)(1)(i) (C) and (ii) states that correspondence (except for a request for reexamination and a corrected or replacement request for reexamination) will be considered timely filed if (a) it is transmitted via the Office's electronic filing system in accordance with 37 CFR 1.6(a)(4), and (b) includes a certificate of transmission for each piece of correspondence stating the date of transmission, which is prior to the expiration of the set period of time in the Office action.

Any inquiry concerning this communication or earlier communications from the Examiner, or as to the status of this proceeding, should be directed to the Central Reexamination Unit at telephone number (571) 272-7705.

Application/Control Number: 90/011,033

Page 12

Art Unit: 3992

Signed:

/Andrew Nalven/

Andrew Nalven
CRU Examiner
GAU 3992
(571) 272-3839

Conferee: ESK

Conferee: ajj

Under the Paperwork Reduction Act of 1995, no persons are required to respond to a collection of information unless it contains a valid OMB control number.

INFORMATION DISCLOSURE STATEMENT BY APPLICANT (Not for submission under 37 CFR 1.99)	Application Number	90/011,033
	Filing Date	
	First Named Inventor	DANIEL J. SAMUEL
	Art Unit	
	Examiner Name	
	Attorney Docket Number	8330.003

U.S.PATENTS						
Examiner Initial*	Cite No	Patent Number	Kind Code ¹	Issue Date	Name of Patentee or Applicant of cited Document	Pages, Columns, Lines where Relevant Passages or Relevant Figures Appear
AW	1	5736982		1998-04-07	Suzuki et al.	
	2					
	3					
	4					
	5					

If you wish to add additional U.S. Patent citation information please click the Add button.

U.S.PATENT APPLICATION PUBLICATIONS

Examiner Initial*	Cite No	Publication Number	Kind Code ¹	Publication Date	Name of Patentee or Applicant of cited Document	Pages, Columns, Lines where Relevant Passages or Relevant Figures Appear
	1					

If you wish to add additional U.S. Published Application citation information please click the Add button.

FOREIGN PATENT DOCUMENTS

INFORMATION DISCLOSURE STATEMENT BY APPLICANT (Not for submission under 37 CFR 1.99)	Application Number		
	Filing Date		
	First Named Inventor	DANIEL J. SAMUEL	
	Art Unit		
	Examiner Name		
	Attorney Docket Number	8330.003	

Examiner Initial*	Cite No	Foreign Document Number ³	Country Code ² j	Kind Code ⁴	Publication Date	Name of Patentee or Applicant of cited Document	Pages, Columns, Lines where Relevant Passages or Relevant Figures Appear	T ⁵
	1							<input type="checkbox"/>

If you wish to add additional Foreign Patent Document citation information please click the Add button

NON-PATENT LITERATURE DOCUMENTS

Examiner Initials*	Cite No	Include name of the author (in CAPITAL LETTERS), title of the article (when appropriate), title of the item (book, magazine, journal, serial, symposium, catalog, etc), date, pages(s), volume-issue number(s), publisher, city and/or country where published.	T ⁵
<i>AW</i>	1	Server2.5pi4.tar.gz ("Server Code") and BRMH-1.7.tar.gz ("Client Code") (source code dated no later than August 1994) ("Netrek")	<input type="checkbox"/>
	2	J. OIKARINEN ET AL. RFC 1459, "Internet Relay Chat Protocol", published May 1993 ("IRC RFC").	<input type="checkbox"/>
	3	R. FRIEDMAN ET AL. "Packing Messages as a Tool for Boosting the Performance of Total Ordering Protocols", Dept. of Science of Cornell University, published July 7, 1995 ("Friedman").	<input type="checkbox"/>
	4	DANIEL J. VAN HOOK, JAMES O. CALVIN, MICHAEL K. NEWTON, and DAVID A. FUSCO, "An Approach to DIS Scaleability," 11th DIS Workshop, 26-30 Sept. 1994 ("Van Hook").	<input type="checkbox"/>
	5	IEEE 1278-1993 "IEEE Standard for Information Technology- Protocols for Distributed Interactive Simulation Applications", approved March 18, 1993, and published in 1993 ("DIS")	<input type="checkbox"/>
	6	T. A. FUNKHOUSER, "RING: A Client-Server System for Multi-User Virtual Environments," Association of Computing Machinery, 1995 Symposium on Interactive 3D Graphics, Monterey CA, April 9-12, 19952 ("RING").	<input type="checkbox"/>
	7	ANDY MCFADDEN, "The History of Netrek", published January 1, 1994 ("McFadden").	<input type="checkbox"/>

INFORMATION DISCLOSURE STATEMENT BY APPLICANT (Not for submission under 37 CFR 1.99)	Application Number		
	Filing Date		
	First Named Inventor	DANIEL J. SAMUEL	
	Art Unit		
	Examiner Name		
	Attorney Docket Number	8330.003	

AW	8	MICHAEL R. MACEDONIA, "Exploiting Reality with Multicast Groups", published September 1995 ("Macedonia")	<input type="checkbox"/>
----	---	--	--------------------------

If you wish to add additional non-patent literature document citation information please click the Add button

EXAMINER SIGNATURE

Examiner Signature		Date Considered	7/21/10
--------------------	---	-----------------	---------

*EXAMINER: Initial if reference considered, whether or not citation is in conformance with MPEP 609. Draw line through a citation if not in conformance and not considered. Include copy of this form with next communication to applicant.

¹ See Kind Codes of USPTO Patent Documents at www.USPTO.GOV or MPEP 901.04. ² Enter office that issued the document, by the two-letter code (WIPO Standard ST.3). ³ For Japanese patent documents, the indication of the year of the reign of the Emperor must precede the serial number of the patent document. ⁴ Kind of document by the appropriate symbols as indicated on the document under WIPO Standard ST.16 if possible. ⁵ Applicant is to place a check mark here if English language translation is attached.

Reexamination 	Application/Control No. 90/011,033	Applicant(s)/Patent Under Reexamination 5,822,523
	Certificate Date	Certificate Number

Requester Correspondence Address: <input type="checkbox"/> Patent Owner <input checked="" type="checkbox"/> Third Party
NOVAK DRUCE & QUIGG, LLP (NDQ REEXAMINATION GROUP) 1000 LOUISIANA STREET FIFTY-THIRD FLOOR HOUSTON, TX 77002

LITIGATION REVIEW <input checked="" type="checkbox"/>	aln <small>(examiner initials)</small>	7/21/10 <small>(date)</small>
Case Name		Director Initials
Paltalk v Sony - 2:09CV274 - OPEN		<i>Eve Hand to Gm</i>
2:06CV367 - CLOSED		↓
3:99CV4506 - CLOSED		

COPENDING OFFICE PROCEEDINGS	
TYPE OF PROCEEDING	NUMBER
1. none	
2.	
3.	
4.	

Search Notes 	Application/Control No. 90011033	Applicant(s)/Patent Under Reexamination 5,822,523
	Examiner ***	Art Unit 3992

SEARCHED			
Class	Subclass	Date	Examiner
395	200.170		

SEARCH NOTES		
Search Notes	Date	Examiner
Reviewed Patented File's Prosecution History	7/21/10	aln

INTERFERENCE SEARCH			
Class	Subclass	Date	Examiner

--	--

**FIRST
INFORMATION DISCLOSURE
STATEMENT BY APPLICANT**

(use as many sheets as necessary)

In re Reexamination of U.S. Patent No. / Control No.:	5,822,523 / 90/011,033
Issue Date:	October 13, 1998
First Named Inventor	Jeffrey J. Rothschild et al.
Confirmation/Group Art Unit No.	1686 / 3992
Attorney Docket No.	0078494-000001

Sheet 1 of 7

U.S. PATENT DOCUMENTS

Exmr. Initials	Ref. No.	Document Number-Kind Code	Publication/Issue Date MM-DD-YYYY	Name of Patentee or Applicant of Cited Document	Pages, Columns, Lines Where Relevant Passages or Figures Appear
	1	4,479,195	10-23-1984	HERR et al.	
	2	4,558,180	12-10-1985	SCORDO	
	3	5,079,767	01-07-1992	PERLMAN	
	4	5,247,615	09-21-1993	MORI et al.	
	5	5,260,942	11-09-1993	AUERACH et al.	
	6	5,329,619	07-12-1994	PAGÉ et al.	
	7	5,436,896	07-25-1995	ANDERSON et al.	
	8	5,530,699	06-25-1996	KLINE	
	9	5,539,741	07-23-1996	BARRACLOUGH et al.	
	10	5,586,257	12-17-1996	PERLMAN	
	11	5,608,726	03-04-1997	VIRGILE	
	12	5,659,691	08-19-1997	DURWARD et al.	
	13	5,684,800	11-04-1997	DOBBINS et al.	
	14	5,736,982	04-07-1998	SUZUKI et al.	
	15	5,787,085	07-28-1998	FOX	
	16	5,805,823	09-08-1998	SEITZ	
	17	6,041,166	03-21-2000	HART et al.	
	18	6,076,117	06-13-2000	BILLINGS	
	19	6,115,747	09-05-2000	BILLINGS et al.	
	20	6,269,404	07-31-2001	HART et al.	
	21	6,426,954	07-30-2002	KRAUSE	
	22	6,873,627	03-29-2005	MILLER et al.	
	123	5,829,041	10-27-1998	OKAMOTO et al.	
	124	5,841,980	11-24-1998	WATERS et al.	
	125	7,493,558	02-17-2009	LEAHY et al.	
	126	4,572,509	02-25-1986	SITRICK	
	127	5,630,757	05-20-1997	GAGIN et al.	
	128	5,785,630	07-28-1998	BOBICK et al.	
	129	5,890,995	04-06-1999	BOBICK et al.	
	130	5,466,200	11-14-1995	ULRICH et al.	
	131	5,690,582	11-25-1997	ULRICH et al.	
	132	5,598,535	01-28-1997	BRECH et al.	
	133	5,649,103	07-15-1997	DATTA et al.	
	137	6,304,550	10-16-2001	FOX	

Examiner Signature	Date Considered
--------------------	-----------------

*EXAMINER: Initial if reference considered, whether or not citation is in conformance with M.P.E.P. § 609. Draw line through citation if not in conformance and not considered. Include copy of this form with next communication to Applicant.

**FIRST
INFORMATION DISCLOSURE
STATEMENT BY APPLICANT**

(use as many sheets as necessary)

Sheet 2 of 7

In re Reexamination of U.S. Patent No. / Control No.:	5,822,523 / 90/011,033
Issue Date:	October 13, 1998
First Named Inventor	Jeffrey J. Rothschild et al.
Confirmation/Group Art Unit No.	1686 / 3992
Attorney Docket No.	0078494-000001

FOREIGN PATENT DOCUMENTS

Exmr. Initials	Ref. No.	Foreign Patent Document		Name of Patentee or Applicant of Cited Document	STATUS							
		Country Code ¹ , Number, Kind Code	Publication Date (MM-DD-YYYY)		Translation	Partial Translation	Eng. Lang. Summary	Search Report	IPER	Abstract	Cited in Spec. / Pg. No(s).	
	23	EP 0598969 A1	06-01-1994	IBM CORPORATION							X	
	24	EP 0687088 A2	12-13-1995	MOTOROLA, INC.							X	
	25	EP 0714684 A1	06-05-1996	NET GAME LIMITED							X	
	26	WO 94/24803	10-27-1994	AT&T CORP.								
	27	WO 97/04386	02-06-1997	3COM CORPORATION								
	97	JP 2-2262	01-08-1990	FUJI FACOM CORP.		X					X	
	98	JP 2-192344	07-30-1990	FUJITSU LTD.		X					X	
	99	JP 4-249938	09-04-1992	FUJITSU LTD.		X					X	
	100	JP 5-199257	08-20-1993	NEC CORP.		X					X	
	101	JP 5-219096	08-27-1993	NEC CORP.		X					X	
	102	JP 5-336155	12-17-1993	NEC CORP.		X					X	
	103	JP 6-30041	02-04-1994	ALCATEL NV		X					X	
	104	JP 6-152601	05-31-1994	MATSUSHITA ELECTRIC IND CO. LTD.		X					X	
	105	JP 7-254900	10-03-1995	FUJITSU LTD.		X					X	
	118	EP 0 384 876 B1	08-29-1990	IBM CORPORATION								

¹Enter Office that issued the document, by the two-letter code.

NON-PATENT LITERATURE DOCUMENTS

Include name of the author (in CAPITAL LETTERS), title of the article (when appropriate), title of the item (book, magazine, journal, serial, symposium, catalog, etc.), date, page(s), volume-issue number(s), publisher, city and/or country where published.

Exmr. Initials	Ref. No.	Include name of the author (in CAPITAL LETTERS), title of the article (when appropriate), title of the item (book, magazine, journal, serial, symposium, catalog, etc.), date, page(s), volume-issue number(s), publisher, city and/or country where published.
	28	MACEDONIA, Michael R. et al., "A Taxonomy for Networked Virtual Environments", Immersive Telepresence, pp. 48-56
	29	FUNKHOUSER, Thomas A. "RING: A Client-Server System for Multi-User Virtual Environments", 1995 Symposium on Interactive 3D Graphics, pp. 85-209, Monterey, CA
	30	VAN HOOK, Daniel J. et al., "An Approach to DIS Scalability", 11th DIS Workshop, pp. 1-9, September 26-30, 1994
	31	OIKARINEN, J. et al., "Internet Relay Chat Protocol", Network Working Group, May, 1993, pp. 1-61
	32	IEEE Standard for Information Technology -- Protocols for Distributed Interactive Simulation Applications, IEEE, November 10, 2009, pp. 1-64
	34	ABDEL-WAHAB, Hussein, "Reliable Information Service for Internet Computer Conferencing", IEEE, 1993, pp. 128-142
	35	AMIR, Yair, "Replication Using Group Communication Over a Partitioned Network", Thesis, 1995, pp. 1-95
	36	BANGAY, Shaun, "Parallel Implementation of a Virtual Reality System on a Transputer Architecture", July 1993, pp. 1-128

Examiner Signature	Date Considered
--------------------	-----------------

*EXAMINER: Initial if reference considered, whether or not citation is in conformance with M.P.E.P. § 609. Draw line through citation if not in conformance and not considered. Include copy of this form with next communication to Applicant.

FIRST
INFORMATION DISCLOSURE
STATEMENT BY APPLICANT

(use as many sheets as necessary)

Sheet 3 of 7

In re Reexamination of U.S. Patent No. / Control No.:	5,822,523 / 90/011,033
Issue Date:	October 13, 1998
First Named Inventor	Jeffrey J. Rothschild et al.
Confirmation/Group Art Unit No.	1686 / 3992
Attorney Docket No.	0078494-000001

NON-PATENT LITERATURE DOCUMENTS

Include name of the author (in CAPITAL LETTERS), title of the article (when appropriate), title of the item (book, magazine, journal, serial, symposium, catalog, etc.), date, page(s), volume-issue number(s), publisher, city and/or country where published.

37	BRUTZMAN, Donald P., "A Virtual World for an Autonomous Underwater Vehicle", Dissertation, December, 1994, pp. 1-293
38	BRUTZMAN, Donald P. et al., "Internetwork Infrastructure Requirements for Virtual Environments", Naval Postgraduate School, pp. 1-11
39	CALVIN, James O. et al., "Stow Realtime Information Transfer and Networking System Architecture", Twelfth Workshop on Standards for the Interoperability of Distributed Simulations", March 13-17, 1995, pp. 1-11
40	CHERITON, David R. et al., "Distributed Process Groups in the V Kernel", ACM Transactions on Computer Systems, Vol. 3, No. 2, May 1985, pp. 77-107
41	CURTIS, Pavel et al., "MUDs Grow Up: Social Virtual Reality in the Real World", Xerox PARC, January 19, 1993, pp. 1-6
42	SANDERS, Robert M. et al., "The Xpress Transfer Protocol (XTP) A Tutorial (Expanded Version), NASA Johnson Space Center, Engineering directorate, Flight Data Systems Division, University of Houston - Clear Lake, January 1990, pp. 1-78
43	DUVVUR, Prasanth, "Managing Data on the World Wide Web "State of the Art Survey of Innovative Tools and Techniques", Massachusetts Institute of Technology, September, 1995, pp. 1-102
44	ELLIS, Clarence A. "A Model and Algorithm for Concurrent Access Within Groupware", University of Colorado at Boulder, Department of Computer Science, April 1992, pp. 0-34
45	EVARD, Remy, "Collaborative Networked Communication: MUDs as Systems Tools", Northeastern University, Monterey, California, November 1-5, 1993, pp. 1-8
46	FRIEDMAN, Roy et al., "Packing Messages as a Tool for Boosting the Performance of Total Ordering Protocols", Cornell University, July 7, 1995, pp. 0-17
47	GAJEWSKA, Hania et al., "Argo: A System for Distributed Collaboration", Digital Equipment Corporation, pp. 1-8
48	GAUDET, Stuart S., "Dynamic Project Collaboration and Control Using the World Wide Web", Massachusetts Institute of Technology, October 1995, pp. 1-225
49	GOLDING, Richard Andrew, "Weak-consistency group communication and membership", Dissertation, December 1992, pp. 1-165
51	GREENHALGH, Chris et al., "MASSIVE: a Distributed Virtual Reality System Incorporating Spatial Trading", IEEE, 1995, pp. 27-34
52	HOFMANN, Markus, "A Generic Concept for Large-Scale Multicast", Proceedings of International Zurich Seminar on Digital Communications, Zurich, Switzerland, Springer Verlag, February 1996, pp. 1-12
53	JABI, Wassim M. et al., "Beyond the Shared Whiteboard: Issues in Computer Supported Collaborative Design", Proceedings of CAAD Future '95: The Sixth International Conference on Computer-Aided Architectural Design Futures, September 24-26, 1995, Singapore, pp. 1-9
54	KAASHOEK, M.F., "Group Communication in Distributed Computer Systems", Vrije Universiteit, Amsterdam, The Netherlands, 1992, pp. 1-220
55	KAASHOEK, M. Frans, "Efficient Reliable Group Communication for Distributed Systems", Vrije Universiteit, Amsterdam, The Netherlands, 1992, pp. 1-51
56	MACEDONIA, Michael R., "A Network Software Architecture for Large Scale Virtual Environments", Dissertation, June 1995, pp. 1-200
57	MACEDONIA, Michael R. et al., "Exploiting Reality with Multicast Groups: A Network Architecture for Large-Scale Virtual Environments", Naval Postgraduate School, IEEE, 1995, pp. 2-10
58	MILLER, Duncan C. MILLER, Sc.D., "Network Performance Requirements for Real-Time Distributed Simulation", Proc. INET, 1994, pp. 241-1 - 241-8
60	PULLEN, J. Mark, "Networking for Distributed Virtual Simulation", Proc. INET, 1994, pp. 243-1 - 243-7

Examiner Signature	Date Considered
--------------------	-----------------

*EXAMINER: Initial if reference considered, whether or not citation is in conformance with M.P.E.P. § 609. Draw line through citation if not in conformance and not considered. Include copy of this form with next communication to Applicant.

FIRST
INFORMATION DISCLOSURE
STATEMENT BY APPLICANT

(use as many sheets as necessary)

Sheet 4 of 7

In re Reexamination of U.S. Patent No. / Control No.:	5,822,523 / 90/011,033
Issue Date:	October 13, 1998
First Named Inventor	Jeffrey J. Rothschild et al.
Confirmation/Group Art Unit No.	1686 / 3992
Attorney Docket No.	0078494-000001

NON-PATENT LITERATURE DOCUMENTS

Include name of the author (in CAPITAL LETTERS), title of the article (when appropriate), title of the item (book, magazine, journal, serial, symposium, catalog, etc.), date, page(s), volume-issue number(s), publisher, city and/or country where published.

61	SDINGH, Gurminder, "BrickNet: A Software Toolkit for Network-Based Virtual Worlds", The Massachusetts Institute of Technology, Presence, Vol. 3, No. 1, Winter 1994, pp. 19-35
62	SRINIVAS, Kankanahalli et al., "MONET: A Multi-media System for Conferencing and Application Sharing in Distributed Systems", CERC Technical Report Series, Research Note, Concurrent Engineering Research Center, West Virginia University, February 1992, pp. 1-19
63	KAASHOEK, M. Frans et al., "Group communication in Amoeba and its applications", The British Computer Society, The Institution of Electrical Engineers and IOP Publishing Ltd., 1993, pp. 48-58
64	VAN RENESSE, Robert et al., "Design and Performance of Horus: A Lightweight Group Communications System", Department of Computer Science, Cornell University, pp. 1-18
65	VAN RENESSE, Robert et al., "Reliable Multicast Between Microkernels", Computer Science Department, Cornell University, USENIX Association, April 27-28, 1992, pp. 267-283
66	FEINER, Steven et al., "A Virtual World for Network Management", 1993 IEEE, October 18-22, 1993, Seattle, WA, pp. 55-61
67	CRABTREE, R.P., "Job networking", IBM Systems J, Vol. 17, No. 3, 1978, pp. 206-220
68	NAGLE, John, "Congestion Control in IP/TCP Internetworks", Computer Communication Review, ACM SIGCOMM, pp. 1-9
69	NAGLE, John, "Congestion Control in IP/TCP Internetworks", Network Working Group, Request for Comments: 896, January 6, 1984, pp. 1-9
71	BARTLE, Dr. Richard, "Interactive Multi-User Computer Games", British Telecom plc., December, 1990, pp. 1-152
72	EPPINGER, Jeffrey L. et al., "Camelot and Avalon, A Distributed Transaction Facility", pp. 1-43
73	GETTYS, Jin et al., "Volume One: Xlib Programming Manual for Version 11 of the X Window System", O'Reilly & Associates, Inc., 1992, pp. 1-513
74	BACON, David F. et al., "Compiler Transformations for High-Performance Computing", Computer Science Division, University of California, Berkeley, CA, pp. 1-79
75	KAZMAN, Rick, "Making WAVES: On the Design of Architectures for Low-end Distributed Virtual Environments", Department of Computer Science, University of Waterloo, 1993 IEEE, pp. 442-449
76	SHAW, Chris et al., "The MR Toolkit Peers Package and Experiment", Department of Computing Science, University of Alberta, July 14, 1994, IEEE, pp. 1-8
77	TIERNAN, T.R., "Synthetic Theater of War - Europe (STOW-E) Final Report", Naval Command, Control and Ocean Surveillance Center, Technical Report 1700, January 1995, San Diego, CA, pp. 1-77
78	HIRANANDANI, Seema et al., "Evaluating Compiler Optimizations for Fortran D", Research Report, pp. 1-40
79	ANDRÉ, Françoise et al., "The Pandore Compiler: Overview and Experimental Results", IRISA, Publication No. 869, October 1994, pp. 1-26
80	BANERJEE, Prithviraj et al., "The PARADIGM Compiler for Distributed-Memory Message Passing Multicomputers", First International Workshop on Parallel Processing, Bangalore, India, December 1994, pp. 1-9
81	WANG, Qunjie et al., "EM - An Environment Manager for Building Networked Virtual Environments", 1995 IEEE, pp. 11-18
82	SINGH, Gurminder et al., "BrickNet: Sharing Object Behaviors on the Net", Institute of Systems Science, 1995 IEEE, pp. 19-25
83	BROLL, Wolfgang, "Interacting in Distributed Collaborative Virtual Environments", "Institute for Applied Information Technology, German National Research Center for Computer Science (GMD), 1995 IEEE, pp. 148-155

Examiner Signature	Date Considered
--------------------	-----------------

*EXAMINER: Initial if reference considered, whether or not citation is in conformance with M.P.E.P. § 609. Draw line through citation if not in conformance and not considered. Include copy of this form with next communication to Applicant.

FIRST
INFORMATION DISCLOSURE
STATEMENT BY APPLICANT

(use as many sheets as necessary)

Sheet 5 of 7

In re Reexamination of U.S. Patent No. / Control No.:	5,822,523 / 90/011,033
Issue Date:	October 13, 1998
First Named Inventor	Jeffrey J. Rothschild et al.
Confirmation/Group Art Unit No.	1686 / 3992
Attorney Docket No.	0078494-000001

NON-PATENT LITERATURE DOCUMENTS

Include name of the author (in CAPITAL LETTERS), title of the article (when appropriate), title of the item (book, magazine, journal, serial, symposium, catalog, etc.), date, page(s), volume-issue number(s), publisher, city and/or country where published.

84	MAXFIELD, John et al., "A Distributed Virtual Environment for Concurrent Engineering", The Keyworth Institute of Manufacturing and Information Systems Engineering, Virtual Working Environments Laboratory, School of Computer Studies, The University of Leeds, United Kingdom, 1995 IEEE, pp. 162-170
85	ZYDA, Michael J., "Networked Virtual Environments", Computer Science Department, Naval Postgraduate School, "1995 IEEE, pp. 230-231
86	WEN, Chih-Po, "Portable Library Support for Irregular Applications", Dissertation, University of California at Berkeley, 1995, pp. 1-134
87	YELICK, Katherine et al., "Parallel Data Structure for Symbolic Computation", University of Berkeley, Computer Science Division, Parallel Symbolic Languages and Systems, October 1995, pp. 1-17
88	WEN, Chih-Po et al., "Portable Runtime Support for Asynchronous Simulation", Computer Science Division, University of California, International Conference on Parallel Processing, 1995, pp. 1-10
89	ITSUKI, Noda, "Soccer Server: a simulator of RoboCup", pp. 1-6
92	WANG, Qunjie, "Networked Virtual Reality", Thesis, University of Alberta, pp. 1-108
96	MACEDONIA, Michael R. et al., "NPSNET: A MULTI-PLAYER 3D VIRTUAL ENVIRONMENT OVER THE INTERNET", 1995 Symposium on Interactive 3D Graphics, Monterey, CA, pp. 93, 94 and 210
107	VIN, Harrick M. et al., "Hierarchical Conferencing Architectures for Inter-Group Multimedia Collaboration", Multimedia Laboratory, Department of Computer Science and Engineering, University of California at San Diego, pp. 43-54, 1991 ACM
108	KEUNE, C. M. et al., "Synthetic Theater of War-Europe (STOW-E) Technical Analysis", Technical Report 1703, August 1995, pp. 1-75
109	RANGAN, P. VENKAT et al., "Communication Architectures and Algorithms for Media Mixing in Multimedia Conferences", IEEE/ACM Transactions on Networking, Vol. 1., No. 1, February 1993, pp. 20-30
110	GONG, Fengmin, "Multipoint Audio and Video Control for Packet-Based Multimedia Conference", MCNC Information Technologies, 1994 ACM, pp. 425-432
111	KOSTRIVAS, John, "Design and Implementation of a Membership Server and Its Application Interface", Thesis, U.S. Navy, Naval Postgraduate School, Monterey, CA, March 10, 1995, pp. 1-74
112	SHAW, V. et al., "A Distributed Multimedia System for Application and Communications", School of Applied Science, Nanyang Technological University, Singapore, 1995 IEEE, pp. 221-229
113	HERDMAN, ROGER C., "Distributed Interactive Simulation of Combat", U.S. Government Printing Office, September 1995, pp. 1-83
114	ZIEGLER, Chaim et al., "Multimedia Conferencing on Local Area Networks", Brooklyn College, 1990 IEEE, pp. 52-61
115	SINGH, Gurminder et al., "Networked Virtual Worlds", Institute of Science Science, National University of Singapore, 1995 IEEE, pp. 44-49
116-117	CHOUDHARY, Alok N. et al., "Proceedings of the 1993 International Conference on Parallel Processing", The Pennsylvania State University, Vol. 11 Software, August 16-20, 1993, CRC Press, Inc., pp. 1-33
120	MALONI, Kelly et al., Net games, Your Guide to the Games People Play on the Electronic Highway", Random House, pp. 1-6
121	SHAH, Rawn et al., "Playing Wargames on the Internet", Complete guide to Empire, Galactic, and Netrek, pp. 1-30
134	ABDEL-WAHAB, H.M., "Multiuser tools architecture for group collaboration in computer networks", Department of Computer Science, Old Dominion University, VA, Vol. 13, No. 3, April 1990, pp. 165-169, Butterworth & Co. Ltd.
135	WATERS, Gill et al., "Three-party talk facility on a computer network", Department of Electronic Systems Engineering, University of Essex, UK, vol. 10, No. 3, June 1987, pp. 115-120

Examiner Signature	Date Considered
--------------------	-----------------

*EXAMINER: Initial if reference considered, whether or not citation is in conformance with M.P.E.P. § 609. Draw line through citation if not in conformance and not considered. Include copy of this form with next communication to Applicant.

**FIRST
INFORMATION DISCLOSURE
STATEMENT BY APPLICANT**

(use as many sheets as necessary)

Sheet 6 of 7

In re Reexamination of U.S. Patent No. / Control No.:	5,822,523 / 90/011,033
Issue Date:	October 13, 1998
First Named Inventor	Jeffrey J. Rothschild et al.
Confirmation/Group Art Unit No.	1686 / 3992
Attorney Docket No.	0078494-000001

NON-PATENT LITERATURE DOCUMENTS

Include name of the author (in CAPITAL LETTERS), title of the article (when appropriate), title of the item (book, magazine, journal, serial, symposium, catalog, etc.), date, page(s), volume-issue number(s), publisher, city and/or country where published.

136	HODEL, HORST, "Multicast-Routing - Grundlage des Multimedia-Conferencing im Internet", Bulletin SEV/VSE, 17/96, pp. 17-22, 3 and 65
138	BLANCHARD, Chuck et al., "What's Net in Reality Built for Two", Proceedings of the ACM Snowbird Conference, February 1990, pp. 1-6
139	MCFADDEN, Andy, "UDP client, the wave of the future", E-mail, http://www.cs.cmu.edu/afs/cs.cmu.edu/.../udp , March 8, 1992, pp. 1-18
145	FLINN, Kelton et al., "Super VGA Air Warrior", Flight Manual, pp. 1-147
146	SNOSWELL, Michael, "Overview of Cyberterm, a Cyberspace Protocol Implementation, pp. 1-12
147	BENEDIKT, Michael, "Cyberspace: First Steps, MIT Press, London, England, pp. 1-35

Examiner Signature	Date Considered
--------------------	-----------------

*EXAMINER: Initial if reference considered, whether or not citation is in conformance with M.P.E.P. § 609. Draw line through citation if not in conformance and not considered. Include copy of this form with next communication to Applicant.

Electronic Acknowledgement Receipt

EFS ID:	8517372
Application Number:	90011033
International Application Number:	
Confirmation Number:	1686
Title of Invention:	SERVER-GROUP MESSAGING SYSTEM FOR INTERACTIVE APPLICATIONS
First Named Inventor/Applicant Name:	5,822,523
Customer Number:	26137
Filer:	Charles F. Wieland III/Christine Becker
Filer Authorized By:	Charles F. Wieland III
Attorney Docket Number:	18830.0003
Receipt Date:	28-SEP-2010
Filing Date:	14-JUN-2010
Time Stamp:	16:54:30
Application Type:	Reexam (Patent Owner)

Payment information:

Submitted with Payment	no
------------------------	----

File Listing:

Document Number	Document Description	File Name	File Size(Bytes)/ Message Digest	Multi Part /.zip	Pages (if appl.)
1	Transmittal Letter	001_1stIDS.pdf	48461 <small>352d585348cd02746f60b176fd73b19bc464da3f</small>	no	1

Warnings:

Information:

2	Reexam Certificate of Service	001_1stIDSCertofServ.pdf	17471	no	1
			77a7778030bfa77e67ae4ca1c76a124d97df2b36		
Warnings:					
Information:					
3	Information Disclosure Statement (IDS) Filed (SB/08)	001_1stPTO1449.pdf	587475	no	6
			a294a18e607d5c8c1cb97ce2793ff5417d0b2d1f		
Warnings:					
Information:					
This is not an USPTO supplied IDS fillable form					
4	Foreign Reference	Ref23_EP969.pdf	1354385	no	25
			55068b6fd0a2fcd9e073ff004161de425ca90f		
Warnings:					
Information:					
5	Foreign Reference	Ref24_EP088.pdf	397415	no	8
			a2aece2557e10633e0f16f2a07bfefd002f886c6		
Warnings:					
Information:					
6	Foreign Reference	Ref25_EP684.pdf	2124757	no	44
			447766613b7cc0e40d2caetb6c64e87a0c6e9eb0		
Warnings:					
Information:					
7	Foreign Reference	Ref26_WO803.pdf	2399405	no	61
			759de7f5fc1ce9d9826ed267c39f4f63a4b7fe5		
Warnings:					
Information:					
8	Foreign Reference	Ref27_WO386.pdf	1295685	no	36
			161f7d78f3da311c85f6d1a905e9015d3b1493d8		
Warnings:					
Information:					
9	NPL Documents	Ref28_Macedonia.pdf	1428725	no	12
			ca5f9731fc5699f9363528fd5ff6ea3cfc2eb2a4		
Warnings:					
Information:					
10	NPL Documents	Ref29_Funkhouser.pdf	1009655	no	9
			4e82d428ecac5ce821d9f6d98be3a792ea3d8e25		

Warnings:					
Information:					
11	NPL Documents	Ref30_VanHook.pdf	741057 3ca1ffb8c714dc198ff540650149408082002032	no	9
Warnings:					
Information:					
12	NPL Documents	Ref31_Oikarinen.pdf	1640944 ebd25d451fb3a40673ee13f561edd245f5d801c	no	61
Warnings:					
Information:					
13	NPL Documents	Ref32_IEEE.pdf	3186292 541c8b0a81146b3c70bc2c111f22da46c12eb2d8	no	64
Warnings:					
Information:					
14	NPL Documents	Ref34_Abdel_Wahab.pdf	740191 85b040c3aea12badea0c8da7e8cb43b82ebce6771	no	15
Warnings:					
Information:					
15	NPL Documents	Ref35_Amir.pdf	4768206 3deaf1fbca808d561e55a1f044ef22aa62cdc17a	no	95
Warnings:					
Information:					
16	NPL Documents	Ref36_Bangay.pdf	6765418 6212a24ef1fc0f8681e9aaa38bfdff4a01ad15f2	no	128
Warnings:					
Information:					
17	NPL Documents	Ref37_Bruzman.pdf	14151349 7b8ed32b08c3d041fcdab36c667d5042a3e0d13c	no	293
Warnings:					
Information:					
18	NPL Documents	Ref38_Bruzmanetal.pdf	924531 34fd62e31b97f4efec9927d0b67dd68009963ff2	no	11
Warnings:					
Information:					
19	NPL Documents	Ref39_Calvin.pdf	633927 7208ad34f58c8cb6a277aa3d37966c1e8565d590	no	13

Warnings:					
Information:					
20	NPL Documents	Ref40_Cheriton.pdf	1916613 d811a727e62bab4ecd70539dd2a5130885b9f249	no	31
Warnings:					
Information:					
21	NPL Documents	Ref41_Curtis.pdf	447912 754fbfe9636872692a33c61f1844738966945270	no	6
Warnings:					
Information:					
22	NPL Documents	Ref42_Sanders.pdf	2726416 809061c9829b4cbb60ab2a38b16a506173aaeaa2	no	78
Warnings:					
Information:					
23	NPL Documents	Ref43_Duvvur.pdf	3904495 f5e0c8ad90732e8f338261aa96dd5b54ceb2576f	no	102
Warnings:					
Information:					
24	NPL Documents	Ref44_Ellis.pdf	2263588 397ecf94e464d2e42946ff2c60f64f794d6637d0	no	35
Warnings:					
Information:					
25	NPL Documents	Ref45_Evard.pdf	711686 3e57d372b8fa1b8cc482f3580e02487a06b96274	no	8
Warnings:					
Information:					
26	NPL Documents	Ref46_Friedman.pdf	860541 4d33004b3782f6adb5096ebcd0498b186270ded8	no	18
Warnings:					
Information:					
27	NPL Documents	Ref47_Gajewska.pdf	783962 c8b7e470221fbcf9b09e1422d19f6485c6fd22af	no	8
Warnings:					
Information:					
28	NPL Documents	Ref48_Gaudet.pdf	6746267 77313a914b5d854d8e98b85f41b46bc109850bf2	no	225

Warnings:					
Information:					
29	NPL Documents	Ref49_Golding.pdf	6618762 b27ec50d92c179c7287e2a4ca1c6f345fd2d1a2	no	165
Warnings:					
Information:					
30	NPL Documents	Ref51_Greenhalgh.pdf	1510209 59aa4ecf4bc356d6a3cdf41e94d8c0faa60540ba	no	8
Warnings:					
Information:					
31	NPL Documents	Ref52_Hofmann.pdf	737821 c692a8328eab27fd0ffb04cb41557b55e75301c9	no	12
Warnings:					
Information:					
32	NPL Documents	Ref53_Jabi.pdf	689828 f5d0ecdbc35980ea2f8e7250a980ff8a398a9fbc	no	9
Warnings:					
Information:					
33	NPL Documents	Ref54_Kaashoek.pdf	10894214 06c33e1592af5acb92d2cc1527f4b8314ac86ae	no	220
Warnings:					
Information:					
34	NPL Documents	Ref55_Kaashoek2.pdf	2920069 af4060bbdbed3cf65d9379f9faae3eb83c69c3856	no	51
Warnings:					
Information:					
35	NPL Documents	Ref56_Macedonia.pdf	5486029 3a4ee1e96d1b190b32c834b74b9afe8c1108f37b	no	200
Warnings:					
Information:					
36	NPL Documents	Ref57_Macedoniaetal.pdf	811116 ca95a47ddb23c6f1f3dd5b41bb8861e226262025	no	9
Warnings:					
Information:					
37	NPL Documents	Ref58_Miller.pdf	585812 119a82321f93c0a3228b4d8bb2979faacffeeec	no	8

Warnings:					
Information:					
38	NPL Documents	Ref60_Pullen.pdf	584010 61eecd2280bd1f29a541fc36a27193e831e13457	no	7
Warnings:					
Information:					
39	NPL Documents	Ref61_Singh.pdf	12450223 39a0e0ea79a28294c5180b83831c9868b3e4d05	no	17
Warnings:					
Information:					
40	NPL Documents	Ref62_Srinivas.pdf	804310 3bcf023163e495db6afb74b1297fc01ab904769f	no	19
Warnings:					
Information:					
41	NPL Documents	Ref63_Kaashoek.pdf	734886 09ba85755d6658b64eedce5f970c6d1da46a5a90	no	11
Warnings:					
Information:					
42	NPL Documents	Ref64_VanRenesse1.pdf	1497317 1994c6a779a704d5545158a195bbb394ee19c6cc	no	18
Warnings:					
Information:					
43	NPL Documents	Ref65_VanRenesse2.PDF	925593 1b5441dca0d013b067f143fb196165dd81170890	no	17
Warnings:					
Information:					
44	NPL Documents	Ref66_Feiner.pdf	568702 1e3f2b41f0de83926134eecd8fa3d92e0862528	no	7
Warnings:					
Information:					
45	NPL Documents	Ref67_Crabtree.pdf	763663 3209ef409fb4f0d8695274bfc604ac7e3fdfb0dc	no	15
Warnings:					
Information:					
46	NPL Documents	Ref68_Nagle1.pdf	597938 fe9dee1041ee0b7b84f0c24e6ace97d050dbefbc	no	9

Warnings:					
Information:					
47	NPL Documents	Ref69_Nagle2.pdf	330270 16ae2e670c83537858b4d3e5173272178d512053	no	9
Warnings:					
Information:					
48	NPL Documents	Ref71_Bartle.pdf	6994462 2ddc408403a848174d3a2f7d8b171e2cbd252b2	no	152
Warnings:					
Information:					
49	NPL Documents	Ref72_Eppinger.pdf	4160559 2e57e7cb8d582f05578518ce64891bdf8c187282	no	43
Warnings:					
Information:					
Total Files Size (in bytes):				125242622	
<p>This Acknowledgement Receipt evidences receipt on the noted date by the USPTO of the indicated documents, characterized by the applicant, and including page counts, where applicable. It serves as evidence of receipt similar to a Post Card, as described in MPEP 503.</p> <p><u>New Applications Under 35 U.S.C. 111</u> If a new application is being filed and the application includes the necessary components for a filing date (see 37 CFR 1.53(b)-(d) and MPEP 506), a Filing Receipt (37 CFR 1.54) will be issued in due course and the date shown on this Acknowledgement Receipt will establish the filing date of the application.</p> <p><u>National Stage of an International Application under 35 U.S.C. 371</u> If a timely submission to enter the national stage of an international application is compliant with the conditions of 35 U.S.C. 371 and other applicable requirements a Form PCT/DO/EO/903 indicating acceptance of the application as a national stage submission under 35 U.S.C. 371 will be issued in addition to the Filing Receipt, in due course.</p> <p><u>New International Application Filed with the USPTO as a Receiving Office</u> If a new international application is being filed and the international application includes the necessary components for an international filing date (see PCT Article 11 and MPEP 1810), a Notification of the International Application Number and of the International Filing Date (Form PCT/RO/105) will be issued in due course, subject to prescriptions concerning national security, and the date shown on this Acknowledgement Receipt will establish the international filing date of the application.</p>					

IN THE UNITED STATES PATENT AND TRADEMARK OFFICE

In re Reexamination of)	MAIL STOP REEXAMINATION
U.S. Patent No. 5,822,523)	Group Art Unit: 3992
Jeffrey J. Rothschild et al.)	Examiner:
Issued: October 13, 1998)	Confirmation No.: 1686
Reexamination Control No.: 90/011,033)	Information Disclosure Statement Under
For: SERVER-GROUP MESSAGING)	37 C.F.R. § § 1.97, 1.98 and 1.555
SYSTEM FOR INTERACTIVE)	
APPLICATIONS)	

FIRST INFORMATION DISCLOSURE STATEMENT

Commissioner for Patents
P.O. Box 1450
Alexandria, VA 22313-1450

Sir:

The documents cited on the attached form, PTO-1449, are being called to the attention of the Examiner. They were identified during litigation concerning the above-captioned patent or a related patent. Copies of the documents are being submitted herewith, except copies of U.S. patents are not included because they are not required under 37 C.F.R. § 1.98(a). It is respectfully requested that the cited documents be expressly considered during the prosecution of this reexamination proceeding, and the documents be made of record therein and appear among the "references cited" on any reexamination certificate to issue therefrom.

Applicant believes that no fee is required for submission of this statement. However, if a fee is required, the Commissioner is authorized to deduce such fee from the undersigned's Deposit Account No. 02-4800. Please deduct any additional fees from, or credit any overpayment to, the above-noted Deposit Account.

Respectfully submitted,

BUCHANAN INGERSOLL & ROONEY PC

Date: September 28, 2010

By:

Charles F. Wieland III
Registration No. 33096

Customer No. 21839
703 836 6620

Buchanan Ingersoll & Rooney PC
Attorneys & Government Relations Professionals

CERTIFICATE OF SERVICE

It is hereby certified by the undersigned that a true copy of the foregoing First Information Disclosure Statement, PTO-1449 Form(s) and copies of the cited documents were sent via courier to:

NOVAK DRUCE + QUIGG, LLP
1000 Louisiana Street
53rd Floor
Houston, Texas 77002

on this 28th day of September, 2010.

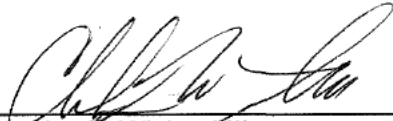

Charles F. Wieland III
Registration No. 33096

Electronic Acknowledgement Receipt

EFS ID:	8518027
Application Number:	90011033
International Application Number:	
Confirmation Number:	1686
Title of Invention:	SERVER-GROUP MESSAGING SYSTEM FOR INTERACTIVE APPLICATIONS
First Named Inventor/Applicant Name:	5,822,523
Customer Number:	26137
Filer:	Charles F. Wieland III/Christine Becker
Filer Authorized By:	Charles F. Wieland III
Attorney Docket Number:	18830.0003
Receipt Date:	28-SEP-2010
Filing Date:	14-JUN-2010
Time Stamp:	17:31:51
Application Type:	Reexam (Patent Owner)

Payment information:

Submitted with Payment	no
------------------------	----

File Listing:

Document Number	Document Description	File Name	File Size(Bytes)/ Message Digest	Multi Part /.zip	Pages (if appl.)
1	NPL Documents	Ref73_Gettys_part1.pdf	15057503 <small>41d47d7198487bfb8443290c1937201b7f9c6509</small>	no	250

Warnings:

Information:

2	NPL Documents	Ref73_Gettys_part2.pdf	14223359 2b8469da552f290198653cbfd5ef5f16db25cce	no	263
Warnings:					
Information:					
3	NPL Documents	Ref74_Bacon.pdf	7101782 38fa2196fe41ee9d183c7f01614a9d4f8aa90d	no	79
Warnings:					
Information:					
4	NPL Documents	Ref75_Kazman.pdf	721048 e80b166c626de59acb6805163dae05a91fc9ab18	no	8
Warnings:					
Information:					
5	NPL Documents	Ref76_Shaw.pdf	664052 efd0a83934b843a0ef9f8b9925d87f926205da0a	no	8
Warnings:					
Information:					
6	NPL Documents	Ref77_Tiernan.pdf	5228693 42ddd89164b7330b334c7b1449e00f74ecb53fd0	no	77
Warnings:					
Information:					
7	NPL Documents	Ref78_Hiranandani.pdf	2007853 1c45b7845505e77c1702c238d29a17e86a04fe29	no	40
Warnings:					
Information:					
8	NPL Documents	Ref79_Andre.pdf	972069 47952d094de4c2a897a609c45111917de3523c77	no	26
Warnings:					
Information:					
9	NPL Documents	Ref80_Banerjee.pdf	789935 e64822cb076cb127ca603070e909da331d4305cb	no	9
Warnings:					
Information:					
10	NPL Documents	Ref81_Wang.pdf	1078687 b53b89c5a7c8dc08f8d97d32a0aa7a38331a3b19	no	8
Warnings:					
Information:					

11	NPL Documents	Ref82_Singh.pdf	1043698	no	7
			9782f51a3030e3e3b89c9f854f266e5a140be99e		
Warnings:					
Information:					
12	NPL Documents	Ref83_Broll.pdf	910588	no	8
			7695615f05bd05506bb3af452644b0a98acd3a19		
Warnings:					
Information:					
13	NPL Documents	Ref84_Maxfield.pdf	1072860	no	9
			75c7e0a1efc3bf6062df326ba5ec3bf327ac940		
Warnings:					
Information:					
14	NPL Documents	Ref85_Zyda.pdf	258656	no	2
			ae8fd301e65285d966bb5b1847c1551161089a80		
Warnings:					
Information:					
15	NPL Documents	Ref86_Wen.pdf	5170102	no	134
			224ad1dc10104c674a171813a5dc0579df9598cd		
Warnings:					
Information:					
16	NPL Documents	Ref87_Yelick.pdf	697322	no	17
			697bbab157dab2543e3b5e30a1e919b3e1d7874c		
Warnings:					
Information:					
17	NPL Documents	Ref88_Wen.pdf	677119	no	10
			a3c46f8061799783822719285e7464c70728923f		
Warnings:					
Information:					
18	NPL Documents	Ref89_Itsuki.pdf	548232	no	6
			55fd7cc62031d66f358f7aada5bd74f577bdb567		
Warnings:					
Information:					
19	NPL Documents	Ref92_Wang.pdf	3902225	no	108
			430c5ea4517da79f3060ca039ec71f54cbfbf3d4		
Warnings:					
Information:					

20	NPL Documents	Ref96_Macedonia.pdf	585551 762e9d8272f586b124566f3eacb05b6b7608ebd3	no	3
Warnings:					
Information:					
21	Foreign Reference	Ref97_JP262.pdf	191682 19fd51ce7b8d4e5c1c05f9d4d96f2b5285c6ad36	no	5
Warnings:					
Information:					
22	Foreign Reference	Ref98_JP344.pdf	460260 d8e67bbed2d866cc7b0b96d3cca2e9909fdff8e8c9	no	11
Warnings:					
Information:					
23	Foreign Reference	Ref99_JP938.pdf	334088 922d21677e2fc2fa25dd0cdd1302496aaad210c3	no	6
Warnings:					
Information:					
24	Foreign Reference	Ref100_JP252.pdf	271631 748b4dad2326f3885b75173f85e5d525fba3d29	no	5
Warnings:					
Information:					
25	Foreign Reference	Ref101_JP096.pdf	292810 9a9671885abfbd318a0966f361665468c9c09bed	no	5
Warnings:					
Information:					
26	Foreign Reference	Ref102_JP155.pdf	283519 7325bfa771895ef38156162ec71bfff7887a136a	no	5
Warnings:					
Information:					
27	Foreign Reference	Ref103_JP041.pdf	629277 e06c024bd846fef80f0d4013e7e2cb560cb0a330	no	8
Warnings:					
Information:					
28	Foreign Reference	Ref104_JP601.pdf	350464 f082fcb79148eb204f07878d9c3c87f6d70d7c15	no	6
Warnings:					
Information:					

29	Foreign Reference	Ref105_JP900.pdf	480285 f25a22cd3a4fc95242717789746e5f4d01f1297d	no	8
Warnings:					
Information:					
30	NPL Documents	Ref107_Vin.pdf	760126 ba93b214a933d5cdd3cc94f3b55d9ab3b6ea8dba	no	12
Warnings:					
Information:					
31	NPL Documents	Ref108_Keune.pdf	3174005 dea2c4e267c5264835f3d9aa0d87680f0ea64d	no	75
Warnings:					
Information:					
32	NPL Documents	Ref109_Rangan.pdf	926486 c21e04cadaf123c4e1825e086a0d72688208057	no	11
Warnings:					
Information:					
33	NPL Documents	Ref110_Gong.pdf	813518 7a0334af7fa226d7bdbc5bf05af4cdc63acd2a	no	8
Warnings:					
Information:					
34	NPL Documents	Ref111_Kostrivas.pdf	2839969 33d1b2e8c3fa29e2ea61e0ea78fe8ac5f9c84851	no	74
Warnings:					
Information:					
35	NPL Documents	Ref112_Shaw.pdf	642716 1db36a27f68f8294598085956500443bbb46fde6	no	9
Warnings:					
Information:					
36	NPL Documents	Ref113_Herdman.pdf	5516980 ff380867a41b8aa25d3df8e8d155c94864dd2019	no	83
Warnings:					
Information:					
37	NPL Documents	Ref114_Ziegler.pdf	791427 7d564f64c5f97afb7296150e307387aecba906f6	no	10
Warnings:					
Information:					

38	NPL Documents	Ref115_Singh.pdf	481356	no	6
			1c2a21f0fe16243921de55ecc794d1c7adfa42da		
Warnings:					
Information:					
39	NPL Documents	Ref116_117_Choudhary.pdf	3515917	no	33
			8e417b51b5be8d7ada18ec7a641f810d4e5a0148		
Warnings:					
Information:					
40	NPL Documents	Ref120_Maloni.pdf	1107058	no	6
			d8003a60666684e27c1e44f1487665da64ea14d8		
Warnings:					
Information:					
41	NPL Documents	Ref121_Shah.pdf	4539366	no	30
			392f036ee7929ae9131e8d6c92891dd8b9672ce3		
Warnings:					
Information:					
42	NPL Documents	Ref134_AbdelWahab.pdf	421022	no	5
			29c3961c7d0c319d456bfb5f9a898ef62412d2		
Warnings:					
Information:					
43	NPL Documents	Ref135_Waters.pdf	464934	no	6
			051198bbf0510fd99b3af26da5d66c1ebda10a8		
Warnings:					
Information:					
44	NPL Documents	Ref136_Hodel.pdf	1596376	no	9
			30a07ffe728b3485c107a230897634169d06a84d		
Warnings:					
Information:					
45	NPL Documents	Ref138_Blanchard.pdf	426711	no	6
			8ab16e2fce84e37db21506c836b0fc57fd54f97		
Warnings:					
Information:					
46	NPL Documents	Ref139_Mcfadden.pdf	776860	no	18
			80e5863fee1f7364c843dd39f06c3f66863960c1		
Warnings:					
Information:					

47	NPL Documents	Ref145_Flinn.pdf	10327239 e758ec3df5d8173583b899f1d7efbad07c448d6e	no	147
Warnings:					
Information:					
48	NPL Documents	Ref146_Snoswell.pdf	1235091 3eae5e15ced49f2cee323de4ba365de120191f70	no	12
Warnings:					
Information:					
49	NPL Documents	Ref147_Benedikt.pdf	3500989 959361805762ab7dd86af4d5e469cc4486f2ea22	no	35
Warnings:					
Information:					
Total Files Size (in bytes):				109863496	
<p>This Acknowledgement Receipt evidences receipt on the noted date by the USPTO of the indicated documents, characterized by the applicant, and including page counts, where applicable. It serves as evidence of receipt similar to a Post Card, as described in MPEP 503.</p> <p><u>New Applications Under 35 U.S.C. 111</u> If a new application is being filed and the application includes the necessary components for a filing date (see 37 CFR 1.53(b)-(d) and MPEP 506), a Filing Receipt (37 CFR 1.54) will be issued in due course and the date shown on this Acknowledgement Receipt will establish the filing date of the application.</p> <p><u>National Stage of an International Application under 35 U.S.C. 371</u> If a timely submission to enter the national stage of an international application is compliant with the conditions of 35 U.S.C. 371 and other applicable requirements a Form PCT/DO/EO/903 indicating acceptance of the application as a national stage submission under 35 U.S.C. 371 will be issued in addition to the Filing Receipt, in due course.</p> <p><u>New International Application Filed with the USPTO as a Receiving Office</u> If a new international application is being filed and the international application includes the necessary components for an international filing date (see PCT Article 11 and MPEP 1810), a Notification of the International Application Number and of the International Filing Date (Form PCT/RO/105) will be issued in due course, subject to prescriptions concerning national security, and the date shown on this Acknowledgement Receipt will establish the international filing date of the application.</p>					

**SECOND
INFORMATION DISCLOSURE
STATEMENT BY APPLICANT**

(use as many sheets as necessary)

In re Reexamination of U.S. Patent No. / Control No.:	5,822,523 / 90/011,033
Issue Date:	October 13, 1998
First Named Inventor	Jeffrey J. Rothschild et al.
Confirmation/Group Art Unit No.	1686 / 3992
Attorney Docket No.	0078494-000001

Sheet 1 of 9

U.S. PATENT DOCUMENTS

Exmr. Initials	Ref. No.	Document Number- Kind Code	Publication/Issue Date MM-DD-YYYY	Name of Patentee or Applicant of Cited Document	Pages, Columns, Lines Where Relevant Passages or Figures Appear
		4,572,509	02-1986	SITRICK	
		4,740,954	04-1988	COTTON et al.	
		4,807,224	02-1989	NARON et al.	
		4,984,235	01-1991	HILLIS et al.	
		4,991,171	02-1991	TERASLINNA et al.	
		4,998,199	03-1991	TASHIRO et al.	
		5,079,767	01-1992	PERLMAN	
		5,083,800	01-1992	LOCKTON	
		5,089,813	02-1992	DELUCA et al.	
		5,117,420	05-1992	HILLIS et al.	
		5,150,410	09-1992	BERTRAND	
		5,150,464	09-1992	SIDHU et al.	
		5,245,608	09-1993	DEATON, JR. et al.	
		5,257,113	10-1993	CHEN et al.	
		5,287,530	02-1994	DAVIS et al.	
		5,289,460	02-1994	DRAKE, JR. et al.	
		5,297,143	03-1994	FRIDRICH et al.	
		5,309,433	05-1994	CIDON et al.	
		5,309,437	05-1994	PERLMAN et al.	
		5,329,619	07-1994	PAGE et al.	
		5,361,256	11-1994	DOERINGER et al.	
		5,365,523	11-1994	DERBY et al.	
		5,408,261	04-1995	KAMATA et al.	
		5,418,912	05-1995	CHRISTENSON	
		5,430,727	07-1995	CALLON	
		5,453,780	09-1995	CHEN et al.	
		5,475,819	12-1995	MILLER et al.	
		5,481,735	01-1996	MORTENSEN et al.	
		5,502,726	03-1996	FISCHER	
		5,517,494	05-1996	GREEN	
		5,558,339	09-1996	PERLMAN	
		5,581,552	12-1996	CIVANLAR et al.	
		5,586,257	12-1996	PERLMAN	
		5,586,937	12-1996	MENASHE	
		5,590,281	12-1996	STEVENS	
		5,594,732	01-1997	BELL et al.	
		5,630,757	05-1997	GAGIN et al.	
		5,634,011	05-1997	AUERBACH et al.	
		5,674,127	10-1997	HORSTMANN et al.	
		5,685,775	11-1997	BAKOGLU et al.	
		5,729,540	03-1998	WEGRZYN	

Examiner Signature		Date Considered	
--------------------	--	-----------------	--

*EXAMINER: Initial if reference considered, whether or not citation is in conformance with M.P.E.P. § 609. Draw line through citation if not in conformance and not considered. Include copy of this form with next communication to Applicant.

**SECOND
INFORMATION DISCLOSURE
STATEMENT BY APPLICANT**

(use as many sheets as necessary)

Sheet 2 of 9

In re Reexamination of U.S. Patent No. / Control No.:	5,822,523 / 90/011,033
Issue Date:	October 13, 1998
First Named Inventor	Jeffrey J. Rothschild et al.
Confirmation/Group Art Unit No.	1686 / 3992
Attorney Docket No.	0078494-000001

	5,740,170	04-1998	ANDOU et al.
	5,740,231	04-1998	COHN et al.
	5,761,436	06-1998	NIELSEN
	5,778,187	07-1998	MONTEIRO et al.
	5,784,568	06-1998	NEEDHAM
	5,805,830	09-1998	REESE et al.
	5,812,552	09-1998	ARORA et al.
	5,930,259	07-1999	KATSUBE et al.
	5,946,308	08-1999	DOBBINS et al.
	5,956,485	09-1999	PERLMAN

FOREIGN PATENT DOCUMENTS

Exmr. Initials	Ref. No.	Foreign Patent Document Country Code ¹ , Number, Kind Code	Publication Date (MM-DD-YYYY)	Name of Patentee or Applicant of Cited Document	STATUS								
					Translation	Translation	Partial Translation	Eng. Lang. Summary	Search Report	IPER	Abstract	Cited in Spec. / Pg. No(s).	
		EP 0 637 149	02-1995	DIGITAL EQUIPMENT CORP.									
		WO 93/15572	08-1993	NELLCOR INC.									
		WO 95/10911	04-1995	INTEL CORP.									
		WO 95/10908	04-1995	INTEL CORP.									

¹Enter Office that issued the document, by the two-letter code.

NON-PATENT LITERATURE DOCUMENTS

Include name of the author (in CAPITAL LETTERS), title of the article (when appropriate), title of the item (book, magazine, journal, serial, symposium, catalog, etc.), date, page(s), volume-issue number(s), publisher, city and/or country where published.

Exmr. Initials	Ref. No.	Include name of the author (in CAPITAL LETTERS), title of the article (when appropriate), title of the item (book, magazine, journal, serial, symposium, catalog, etc.), date, page(s), volume-issue number(s), publisher, city and/or country where published.
		AHUJA, S.R., et al., "The Rapport Multimedia Conferencing System," Conference on Office Information Systems 1988, pp. 1-7.
		ARMSTRONG, S. et al., "Multicast Transport Protocol," Network Working Group Request For Comments: 1301, 1992, 31 pages.
		BERGLUND, E.J. et al. "Amaze: A Distributed Multi-Player Game Program using the Distributed V Kernel," IEEE Proceedings of the Fourth Int'l Conf. on Distributed Systems, 1984, pp. 248-253.
		BRADEN, R. (ed.), "Requirements for Internet Hosts--Communication Layers," Network Working Group Request for Comments: 1122, Oct. 1989, 100 pages.
		BRADEN, R. (ed.), "Requirements for Internet Hosts--Application and Support," Network Working Group Request for Comments: 1123, Oct. 1989, 84 pages.
		BRADEN, R. et al., "Integrated Services in the Internet Architecture: An Overview," Network Working Group Request for Comments: 1633, Jun. 1994, 27 pages.
		BRAUDES, R. et al., "Requirements for Multicast Protocols," Network Working Group Request for Comments: 1458, 05-1993, 16 pages.

Examiner Signature	Date Considered
--------------------	-----------------

*EXAMINER: Initial if reference considered, whether or not citation is in conformance with M.P.E.P. § 609. Draw line through citation if not in conformance and not considered. Include copy of this form with next communication to Applicant.

**SECOND
INFORMATION DISCLOSURE
STATEMENT BY APPLICANT**

(use as many sheets as necessary)

Sheet 3 of 9

In re Reexamination of U.S. Patent No. / Control No.:	5,822,523 / 90/011,033
Issue Date:	October 13, 1998
First Named Inventor	Jeffrey J. Rothschild et al.
Confirmation/Group Art Unit No.	1686 / 3992
Attorney Docket No.	0078494-000001

NON-PATENT LITERATURE DOCUMENTS

Include name of the author (in CAPITAL LETTERS), title of the article (when appropriate), title of the item (book, magazine, journal, serial, symposium, catalog, etc.), date, page(s), volume-issue number(s), publisher, city and/or country where published.

	CAMERON, P. et al., "Transport Multiplexing Protocol (TMux)," Network Working Group Request for Comments: 1692, Aug. 1994, 10 pages.
	CHERITON, D.R. et al., "Host Groups: A Multicast Extension for Datagram Internetworks," ACM/IEEE Proceedings of the Ninth Data Communications Symposium, Sep. 10-13, 1985, pp. 172-179.
	CHIMIACK, W., "A Comment on Packet Video Remote Conferencing and the Transport/Network Layers," Network Working Group Request for Comments: 1453, Apr. 1993, 9 pages.
	CROCKER, D.H., "Standard For The Format Of ARPA Internet Text Messages," IETF RFC #822, Aug. 13, 1982, 43 pages.
	DEERING, S.E. et al., "Host Groups: A Multicast Extension to the Internet Protocol," Network Working Group Request for Comments: 966, Dec. 1985, 23 pages.
	DEERING, S., "Host Extensions for IP Multicasting," Network Working Group for Comments: 1054, 05-1988, 16 pages.
	DEERING, S., "Host Extensions for IP Multicasting," Network Working Group Request for Comments: 1112, Aug., 1989, 14 pages.
	HANDLEY, M.J., "The Car System: Multimedia in Support of Collaborative Design," Computing and Control Division Colloquium on 'Multimedia and Professional Applications', Feb. 3, 1993, pp. 8/1-8/5.
	HENCKEL, L., "Multipier Transport Services for Multimedia Applications," High Performance Networking, V: Proc. Of the IFIP TC6/WG6.4 Fifth International Conference on High Performance Networking, Jun. 27-Jul. 1, 1994, pp. 167-184.
	KIRSCH, T. et al., "Communication support for cooperative work," Computer Communications, vol. 16, No. 9, Sep. 1993, pp. 594-602.
	LAUWERS, J.C. et al., "Replicated Architectures for Shared Window Systems: A Critique," Proc. of the ACM Conference on Office Information Systems, 1990, pp. 249-260.
	Leung, Y-W. et al., "Optimum Connection Paths for a Class of Videoconferences," Int'l Conference on Comm. ICC 91, vol. 1 of 3, Jun. 23-26, 1991, pp. 0859-0865.
	LEUNG, Y-W. et al., "A Modular Multirate Video Distributing System-Design and Dimensioning," IEEE/ACM Transactions on Networking, vol. 2, No. 6, Dec. 1994, pp. 549-557.
	LI, Y. et al., "Multipoint Conferencing for Mobile Communications Network," 2.sup.nd Int'l. Conference on Universal Personal Communications, Oct. 12-15, 1993, pp. 212-216.
	Multipoint Control Units For Audiovisual Systems Using Digital Channels Up To 2 Mbit/s, ITU Standard Draft H.231, 1993, pp. 11-22.
	NGOH, L., "Multicast Support for Group Communications," Computer Networks and ISDN Systems, 166-178, Oct. 1991, pp. 166-178.
	POSTEL, J.B., "Simple Mail Transfer Protocol," Internet Engineering Task Force (IETF) Request for Comments (RFC) 821, Aug. 1982, 59 pages.
	RAJAGOPALAN, B., "Membership protocols for distributed conference control," Computer Communications, vol. 18, No. 10, Oct. 1995, pp. 695-708.
	RAMANATHAN, S. et al., "Optimal Communication Architecture for Multimedia Conferencing in Distributed Systems," The 12.sup.th Int'l Conference on Distributed Computing Systems, Jun. 9-12, 1992, pp. 46-53.
	ROSE, M.T. et al., "Proposed Standard for Message Encapsulation," Network Working Group Request for Comments: 934, Jan. 1985, 9 pages.
	SCHAFFER, U., "MPPS--A Multiparty Presentation Service," Upper Layer Protocols, Architectures and Applications: Proc. Of the IFIP TC6/WG6.5 International Conference on Upper Layer Protocols, Architectures and Applications, Jun. 1-3, 1994, pp. 243-256.
	SCHOOLER, E.M., "The Impact of Scaling on a Multimedia Connection Architecture," ACM Journal of Multimedia Systems, vol. 1, No. 1, 1993, pp. 1-10.

Examiner Signature	Date Considered
--------------------	-----------------

*EXAMINER: Initial if reference considered, whether or not citation is in conformance with M.P.E.P. § 609. Draw line through citation if not in conformance and not considered. Include copy of this form with next communication to Applicant.

SECOND
INFORMATION DISCLOSURE
STATEMENT BY APPLICANT

(use as many sheets as necessary)

Sheet 4 of 9

In re Reexamination of U.S. Patent No. / Control No.:	5,822,523 / 90/011,033
Issue Date:	October 13, 1998
First Named Inventor	Jeffrey J. Rothschild et al.
Confirmation/Group Art Unit No.	1686 / 3992
Attorney Docket No.	0078494-000001

NON-PATENT LITERATURE DOCUMENTS

Include name of the author (in CAPITAL LETTERS), title of the article (when appropriate), title of the item (book, magazine, journal, serial, symposium, catalog, etc.), date, page(s), volume-issue number(s), publisher, city and/or country where published.

	SCHULZRINNE, H., "RTP: A Transport Protocol for Real-Time Applications," IETF Internet Draft draft-ietf-avt-rtp-00.doc, Dec. 15, 1992, 23 pages.
	SCHULZRINNE, H. et al., "RTP: A Transport Protocol for Real-Time Applications," IETF Internet Draft draft-ietf-avt-rtp-01.txt, 05-6, 1993, 16 pages.
	SCHULZRINNE, H. et al., "RTP: A Transport Protocol for Real-Time Applications," IETF Internet Draft draft-ietf-avt-rtp-02.txt, Jul. 30, 1993, 24 pages.
	SCHULZRINNE, H. et al., "RTP: A Transport Protocol for Real-Time Applications," IETF Internet Draft draft-ietf-avt-rtp-04.txt, Oct. 20, 1993, 33 pages.
	SCHULZRINNE, H. et al., "RTP: A Transport Protocol for Real-Time Applications," Network Working Group Request for Comments: 1889, Jan. 1996, 61 pages.
	SINGHAL, S.K. et al., "Using a Position History-Based Protocol for Distributed Object Visualization," Stanford University Technical Report No. CS-TR-94-1505, 1994, 25 pages.
	"System for Establishing Communication Between Audiovisual Terminals Using Digital Channels Up To 2 Mbit/s," Amended/New Draft Recommendation Of The H.240-Series Submitted To The Xth CCITT Plenary Assembly COM XV-R 94-E, 05-1992, 68 pages.
	THOMAS, E., "Listserv Distribute Protocol," Network Working Group Request for Comments: 1429, Feb., 1993, 7 pages.
	TURLETTI, T., "H.261 software codec for videoconferencing over the Internet," Rapports de Recherche No. 1834, Jan. 1993, pp. 1-18.
	VIN, H.M. et al., "Multimedia Conferencing in the Etherphone Environment," Computer: Multimedia Information Systems, Oct. 1991, pp. 69-79.
	VONDERWEIDT, G. et al., "A Multipoint Communication Service for Interactive Applications," IEEE Transactions on Communications, vol. 39, No. 12, Dec. 1991, pp. 1875-1885.
	WAITZMAN, D. et al., "Distance Vector Multicast Routing Protocol," Network Working Group Request for Comments: 1075, Nov. 1988, 20 pages.
	WANCHO, F., Digest Message Format: Network Working Group Request for Comments: 1153, Apr. 1990, 4 pages.
	WATERS, A.G., "Multicast Provision for High Speed Networks," High Performance Networking, IV: Proc. Of the IFIP TC6/WG6.4 Fourth International Conference on High Performance Networking, Dec. 14-18, 1992, pp. 317-332.
	WEISS, G. et al., "Packet Switched Voice Conferencing Across Interconnected Networks," Proceedings 13.sup.th Conference on Local Computer Networks, Oct. 10-12, 1988, pp. 114-124.
	WEISS, G. et al., "A Comparative Analysis of Implementation Mechanism for Packet Voice Conferencing," IEEE INFOCOM '90 Proceedings vol. 1., 1990, pp. 1062-1070.
	WILLEBEEK-LEMAIR, M.H. et al., "Centralized versus Distributed Schemes for Videoconferencing," Proceedings of the Fifth IEEE Computer Society Workshop on Future Trends of Distributed Computing Systems, Aug. 28-30, 1995, pp. 85-93.
	ZARROS, P.N., et al., "Statistical Synchronization Among Participants in Real-Time Multimedia Conference," IEEE InfoCom Proceedings '94 vol. 1, 1994, pp. 912-919.
	ZIEGLER, C. et al., "Implementation Mechanisms for Packet Switched Voice Conferencing," IEEE Journal on Selected Areas in Communications, vol. 7, No. 5, Jun. 1989, pp. 698-706.
	ALTENHOFEN, Michael et al., "The BERKOM Multimedia Collaboration Service," ACM Multimedia, 1993, pp. 457-462.
	ARANGO, Mauricio et al., "Touring Machine: A Software Infrastructure to Support Multimedia Communications," Communications of the ACM, 1993, pp. 186-189.
	CHANG, Wan-the et al., "Call Processing And Signaling In A Desktop Multimedia Conferencing System," Proc. Of GLOBECOM, 1992, pp. 225-229.

Examiner Signature	Date Considered
--------------------	-----------------

*EXAMINER: Initial if reference considered, whether or not citation is in conformance with M.P.E.P. § 609. Draw line through citation if not in conformance and not considered. Include copy of this form with next communication to Applicant.

**SECOND
INFORMATION DISCLOSURE
STATEMENT BY APPLICANT**

(use as many sheets as necessary)

Sheet 5 of 9

In re Reexamination of U.S. Patent No. / Control No.:	5,822,523 / 90/011,033
Issue Date:	October 13, 1998
First Named Inventor	Jeffrey J. Rothschild et al.
Confirmation/Group Art Unit No.	1686 / 3992
Attorney Docket No.	0078494-000001

NON-PATENT LITERATURE DOCUMENTS

Include name of the author (in CAPITAL LETTERS), title of the article (when appropriate), title of the item (book, magazine, journal, serial, symposium, catalog, etc.), date, page(s), volume-issue number(s), publisher, city and/or country where published.

	DEERING, Stephen Edward, Multicast Routing In A Datagram Internetwork, Stanford University Dissertation, Dec. 1991, pp. i-xiii and 1-137.
	HORTON, Mark R., "UUCP Mail Interchange Format Standard," Networking Working Group Request for Comments: 976, Feb. 1986, 10 pages.
	KANTOR, Brian et al., "Network News Transfer Protocol: A Proposed Standard for the Stream-Based Transmission of News," Networking Working Group Request for Comments: 977, Feb. 1986, 22 pages.
	LEINER, B. (ed.), "Critical Issues in High Bandwidth Networking," Networking Working Group Request for Comments: 1077, Nov. 1988, 37 pages.
	NAGLE, John, "Congestion Control in IP/TCP Internetworks," Networking Group Request for Comments: 896, Jan. 6, 1984, 8 pages.
	ONG, Lyndon Y. and Schwartz, Mischa, "Centralized and Distributed Control for Multimedia Conferencing," Proceedings of ICC, 1993, pp. 197-201.
	ROMAHN, Gotz, "System Aspects Of Multipoint Videoconferencing," GLOBECOM, 1987, pp. 723-725.
	SCHULZRINNE et al., "RTP: A Transport Protocol for Real-Time Applications," IETF Internet Draft draft-ietf-avt-rtp-06.txt, Nov. 28, 1994, 93 pages.
	SCHULZRINNE et al., "RTP: A Transport Protocol for Real-Time Applications," IETF Internet Draft draft-ietf-avt-rtp-new-08.txt, Jul. 14, 2000, 90 pages.
	ZELLWEGER, Polle T. et al., "An Overview Of The Etherphone System And Its Applications," 2nd IEEE Conference on Computer Workstations, Mar. 7-10, 1988, pp. 160-168.
	Defendants' Initial Disclosure of Prior Art Under Civil Local Rule 16-7(D)-(E), 21 Pages, Entered Apr. 4, 2000 in HearMe v. Lipstream Networks, Inc. et al., United States District Court for the Northern District of California, Case No. C 99-04506 WHA.
	Defendants' Response Chart For U.S. application No. 5,822,523 Under Civil Local Rule 16-9(B), 26 Pages Plus Exhibits A-K, Dated Jul. 5, 2000, Filed in HearMe v. Lipstream Networks, Inc. et al., United States District Court for the Northern District of California--San Francisco Division, Case No. C 99-04506 WHA.
	Defendants' Response Chart For U.S. application No. 6,018,766 Under Civil Local Rule 16-9(B), 28 Pages Plus Exhibits A-J, Dated Aug. 1, 2000, Filed in HearMe v. Lipstream Networks, Inc. et al., United States District Court for the Northern District of California--San Francisco Division, Case No. C 99-04506 WHA.
	ADDEO, E.J. et al., "A Multi-Media Multi-Point Communication Services Capability for Broadband Networks," 1987, pp. 423-428.
	ADDEO, E.J. et al., "Personal Multi-Media Multi-Point Communication Services for Broadband Networks," 1988, pp. 53-57.
	AGUILAR, Lorenzo, "Datagram Routing for Internet Multicasting," 1984, pp. 58-63.
	AGUILAR, L. et al., "Architecture for a Multimedia Teleconferencing System," 1986, pp. 126-136.
	ARAS, C. et al., "Real-Time Communication in Packet-Switched Networks," 1994, pp. 122-139.
	BAGUETTE, Yves et al., "Comparison of TP4, TCP and XTP--Part 1: Connection Management Mechanisms (*)," vol. 3-N 5, Sep-Oct. 1992, pp. 1-12.
	BAKER, Rusti et al., "Multimedia Processing Model for a Distributed Multimedia I/O System*," Network and Operating System Support for Digital Audio and Video, 1992, pp. 164-175.
	BETTATI, R. et al., "Connection Establishment for Multi-Party Real-Time Communication," Network and Operating Systems Support for Digital Audio and Video, 1995, pp. 240-250.
	BHARATH-KUMAR, Kadaba and et al., "Routing to Multiple Destinations in Computer Networks," 1993, pp. 343-351.

Examiner Signature	Date Considered
--------------------	-----------------

*EXAMINER: Initial if reference considered, whether or not citation is in conformance with M.P.E.P. § 609. Draw line through citation if not in conformance and not considered. Include copy of this form with next communication to Applicant.

**SECOND
INFORMATION DISCLOSURE
STATEMENT BY APPLICANT**

(use as many sheets as necessary)

Sheet 6 of 9

In re Reexamination of U.S. Patent No. / Control No.:	5,822,523 / 90/011,033
Issue Date:	October 13, 1998
First Named Inventor	Jeffrey J. Rothschild et al.
Confirmation/Group Art Unit No.	1686 / 3992
Attorney Docket No.	0078494-000001

NON-PATENT LITERATURE DOCUMENTS

Include name of the author (in CAPITAL LETTERS), title of the article (when appropriate), title of the item (book, magazine, journal, serial, symposium, catalog, etc.), date, page(s), volume-issue number(s), publisher, city and/or country where published.

	BIRCHLER, Barbara D. et al., "Toward a general Theory of Unicast-Based Multicast Communication*," pp. 237-251.
	BIRMAN, K.P. et al., "On Communication Support for Fault Tolerant Process Groups," Network Working Group Request for Comments: 992, Nov. 1986, pp. 1-16.
	BRADEN, Robert et al., "The Design of the RSVP Protocol," RSVP Project: Final Report, 05-27, 1993-Jun. 30, 1995, pp. 1-21.
	BROWN, E.F. et al., "A Continuous Presence Video Conferencing System," 1978, pp. 34.1.1-34.1.4.
	BROWN, T. et al., "Packet Video for Heterogeneous Networks Using CU-SEEME," Proceedings ICIP-96, Sep. 16-19, 1996, pp. 9-12.
	BUBENIK et al., "Multipoint Connection Management in High Speed Networks," 1991, pp. 59-68.
	CASNER, Stephen et al., "N-Way Conferencing with Packet Video," The Third International Workshop on Packet Video, Mar. 22-23, 1990, pp. 1-6.
	CHIA, L.T. et al., "An Experimental Integrated Workstation for Teleconferencing," Integrating Telecommunications and Information Technology on the Desktop, Mar. 1994, pp. 1-5.
	CLARK, David D. et al., "Supporting Real-Time Applications in an Integrated Services Packet Network: Architecture and Mechanism," 1992, pp. 14-26.
	CLARK, William J., "Multipoint Multimedia Conferencing," IEEE Communications Magazine, 05-1992, pp. 44-50.
	COHEN, David M. et al., "Performance Modeling of Video Teleconferencing in ATM Networks," IEEE Transactions on Circuits and Systems for Video Technology, vol. 3, No. 6, Dec. 1993, pp. 408-420.
	CROWCROFT, J. et al., "Multimedia TeleConferencing over International Packet Switched Networks. RN/90/XX," IEEE Conference on Communications Software: Communications for Distributed Applications & Systems, Apr. 18-19, 1991, pp. 23-33.
	DEERING, Stephen et al., "An Architecture for Wide-Area Multicast Routing," 1994, pp. 126-135.
	DEERING, Stephen E., "Multicast Routing in Internetworks and Extended LANs," SIGCOMM '88 Symposium Communications Architectures & Protocols, Aug. 16-19, 1988, pp. 55-64.
	DEERING, Stephen E. et al., "Multicast Routing in Datagram Internetworks and Extended LANs," ACM Transactions on Computer Systems, 05-1990, vol. 8, No. 2, pp. 85-110.
	DEWAN, Prasun et al., "A High-Level and Flexible Framework for Implementing Multiuser User Interfaces," ACM Transactions on Information Systems, Oct. 1992, vol. 10, No. 4, pp. 345-380.
	DRAOLI, M. et al., "Video Conferencing on a LAN/MAN Interconnected System: QoS Evaluation," Proceedings of the Fourth International Conference on Computer Communications and Networks, Sep. 20-23, 1995, pp. 170-177.
	DRAOLI, M. et al., "Videoconferencing on a LAN/MAN Architecture: Service Evaluation and System Dimensioning," Communications Technology Proceedings, 1996, vol. 2, pp. 630-633.
	ENSOR, J. Robert et al., "The Rapport Multimedia Conferencing System--A Software Overview," 2.sup.nd IEEE Conference on Computer Workstations, Mar. 7-10, 1988, pp. 52-58.
	FERRARI, Domenico et al., "Network support for multimedia A discussion of the Tenet Approach," Computer Networks and ISDN Systems, 1994, pp. 1267-1280.
	FLIESSER, R.J. et al., "Design of a Multicast ATM Packet Switch," 1993 Canadian Conference on Electrical and Computer Engineering, vol. 1, pp. 779-783.
	HAN, Jefferson et al., "CU-SeeMe VR Immersive Desktop Teleconferencing," ACM Multimedia, 1996, 9 pages.

Examiner Signature		Date Considered	
--------------------	--	-----------------	--

*EXAMINER: Initial if reference considered, whether or not citation is in conformance with M.P.E.P. § 609. Draw line through citation if not in conformance and not considered. Include copy of this form with next communication to Applicant.

**SECOND
INFORMATION DISCLOSURE
STATEMENT BY APPLICANT**

(use as many sheets as necessary)

Sheet 7 of 9

In re Reexamination of U.S. Patent No. / Control No.:	5,822,523 / 90/011,033
Issue Date:	October 13, 1998
First Named Inventor	Jeffrey J. Rothschild et al.
Confirmation/Group Art Unit No.	1686 / 3992
Attorney Docket No.	0078494-000001

NON-PATENT LITERATURE DOCUMENTS

Include name of the author (in CAPITAL LETTERS), title of the article (when appropriate), title of the item (book, magazine, journal, serial, symposium, catalog, etc.), date, page(s), volume-issue number(s), publisher, city and/or country where published.

	HARJU, Jarmo et al., "Quality and Performance of a Desktop Video Conferencing System in the Network of Interconnected LANs," Proceedings of the 19th Conference on Local Networks, 1994, pp. 365-371.
	HEINRICHS, Bernd et al., "OSI Communication Services Supporting CSCW Applications," SIGDOC '93, 1993, pp. 107-115.
	HERZOG, Shai et al., "Sharing 'Cost' of Multicast Trees: An Axiomatic Analysis," ACM SIGCOMM '95 Conference, Aug. 1995, pp. 1-15.
	HOPPER, Andy, "Pandora--an experimental system for multimedia applications," Operating Systems Review, Apr. 1990, vol. 24, No. 2, pp. 19-34.
	HUANG, Jau-Hsiung et al., "Design and Implementation of Multimedia Conference System on Broadcast Networks*," 18th Conference on Local Computer Networks, 1993, pp. 337-341.
	JIA, Weija, "Implementation of a Reliable Multicast Protocol," Software--Practices & Experiences, Jul. 1997, pp. 813-849.
	KOERNER, Eckhart, "Group Management for a Multimedia Collaboration Service," Presented at EUNICE '96 Summer School on Telecommunications Services, Sep. 23-27, 1996, pp. 1-11.
	KOHLERT, Doug et al., "Implementing a Graphical Multi-user Interface Toolkit," Software--Practice and Experience, Sep. 1993, vol. 23, No. 9, pp. 981-999.
	LARSEN, A.B. et al., "'Continuous Presence' Video Conferencing at 1.5-6Mb/sec," pp. 391-398.
	LAUWERS, J. Chris et al., "Collaboration Awareness in Support of Collaboration Transparency: Requirements for the Next of Shared Window Systems," CHI '90 Proceedings, Apr. 1990, pp. 303-311.
	LEUNG, Wu-hon F. et al., "A Software Architecture for Workstations Supporting Multimedia Conferencing in Packet Switching Networks," IEEE Journal on Selected Areas in Communications, Apr. 1990, vol. 8, No. 1, pp. 380-390.
	LI, L. et al., "Real-time Synchronization Control in Multimedia Distributed Systems," pp. 294-305.
	LI, S. et al., "VC collaborator: a mechanism for video conferencing support*," Proceedings of SPIE, Oct. 1995, pp. 89-99.
	MATHY, L. et al., "The ACCOPI Multimedia Transport Service over ATM," Proceedings of 2ndCOST237 Workshop on Teleservices and Multimedia Communication, Nov. 20-22, 1995, pp. 159-175.
	MATHY, L. et al., "A Group Communication Framework," Broadband Islands '94: Connecting with the End-user, 1994, pp. 167-178.
	MATHY, L. et al., "Towards an Integrated Solution for Multimedia Communications," Rev. AIM, 1996, pp. 3-10.
	MATHY, L. and Bonaventure, O., "QoS Negotiation for Multicast Communications," Multimedia Transport and Teleservices Lecture Notes in Computer Science, 1994, pp. 199-218.
	MCCANNE, S. et al., "Joint Source/Channel Coding for Multicast Packet Video," Proceedings of the International Conference on Image Processing, Oct. 23-26, 1995, pp. 25-28.
	MITZEL, Danny J. et al., "An Architectural Comparison of ST-II and RSVP," 10 pages.
	MITZEL, Danny J. et al., "Asymptotic Resource Consumption in Multicast Reservation Styles," ACM SIGCOMM '94 Conference, Aug. 1994, pp. 1-8.
	MOY, J., "Multicast Extensions to OSPF," Network Working Group Request for Comments: 1584, Mar. 1994, 83 pages.
	NGUYEN, Mai-Huong et al., "MCMP: A Transport/Session Level Distributed Protocol for Desktop Conference Setup," Sep. 1996, vol. 14, No. 7, pp. 1404-1421.
	NICHOLS, Kathleen M., "Network Performance of Packet Video on a Local Area Network," IPCCC '92, Apr. 1-3, 1992, pp. 0659-0666.

Examiner Signature	Date Considered
--------------------	-----------------

*EXAMINER: Initial if reference considered, whether or not citation is in conformance with M.P.E.P. § 609. Draw line through citation if not in conformance and not considered. Include copy of this form with next communication to Applicant.

SECOND
INFORMATION DISCLOSURE
STATEMENT BY APPLICANT

(use as many sheets as necessary)

Sheet 8 of 9

In re Reexamination of U.S. Patent No. / Control No.:	5,822,523 / 90/011,033
Issue Date:	October 13, 1998
First Named Inventor	Jeffrey J. Rothschild et al.
Confirmation/Group Art Unit No.	1686 / 3992
Attorney Docket No.	0078494-000001

NON-PATENT LITERATURE DOCUMENTS

Include name of the author (in CAPITAL LETTERS), title of the article (when appropriate), title of the item (book, magazine, journal, serial, symposium, catalog, etc.), date, page(s), volume-issue number(s), publisher, city and/or country where published.

	NICOLAOU, Cosmos, "An Architecture for Real-Time Multimedia Communications Systems," IEEE Journal on Selected Area Communications, Apr. 1990, vol. 8, No. 1, pp. 391-400.
	PARSA, M. et al., "Scalable Internet Multicast Routing," 4th International Conference on Computer Communications and Networks, Sep. 20-23, 1995, pp. 162-166.
	PARTRIDGE, C., "A Proposed Flow Specification," Network Working Group Request for Comments: 1363, Sep. 1992, 17 pages.
	PASQUALE, Joseph C. et al., "The Multimedia Multicast Channel," Internetworking Research and Experience, 1994, vol. 5, pp. 151-162.
	PASQUALE, Joseph C. et al., "The multimedia multicasting problem," Multimedia Systems, 1998, pp. 43-59.
	RANGAN, P. Venkat, "Communication Architectures and Algorithms for Media Mixing in Multimedia Conferences," IEEE/ACM Transactions on Networking, 1993, pp. 20-30.
	REIBMAN, Amy R. et al., "Traffic Descriptors for VBR Video Teleconferencing Over ATM Networks," IEEE/ACM Transactions on Networking, Jun. 1995, vol. 3, No. 3, pp. 329-339.
	ROBINSON, John et al., "A Multimedia Interactive Conferencing Application for Personal Workstations," IEEE Transactions on Communications, Nov. 1991, pp. 1698-1708.
	ROBINSON, John A., "Communications services architecture for CSCW," Computer Communications, 05-1994, vol. 17, No. 5, pp. 339-347.
	SABRI, Shaker et al., "Video Conferencing Systems," Proceedings of the IEEE, Apr. 1985, vol. 73, No. 4, pp. 671-688.
	SAKATA, Shiro, "Multimedia and Multi-party Desktop Conference System (MERMAID) as Groupware Platform," IEEE Region 10's Ninth Annual International Conference Proceedings, Aug. 1994, pp. 739-743.
	SASSE, M.-A. et al., "Workstation-based multimedia conferencing: Experiences from the MICE project," Integrating Telecommunication and Information Technology on the Desktop, 1994, pp. 1-6.
	SCHMANDT, Chris et al., "An Audio and Telephone Server for Multi-media Workstations," 2nd IEEE Conference on Computer Workstations, Mar. 7-10, 1988, pp. 150-159.
	SCHOOLER, Eve M. et al., Stephen L., "An Architecture for Multimedia Connection Management," Reprinted from the Proceedings IEEE 4th Comsoc International Workshop on Multimedia Communications, Apr. 1992, pp. 271-274.
	SCHOOLER, Eve M., "Case Study: Multimedia Conference Control in a Packet-Switched Teleconferencing System," Reprinted from the Journal of Internetworking: Research and Experience, Jun. 1993, vol. 4, No. 2, pp. 99-120.
	SCHOOLER, Eve M., A Distributed Architecture for Multimedia Conference Control, ISI Research Report No. ISI/RR-91-289, Nov. 1991, pp. 1-18.
	SCHOOLER, Eve M. et al., "Multimedia Conferencing: Has it come of age?" Reprinted from the Proceedings 24th Hawaii International Conference on Systems Sciences, Jan. 1991, vol. 3, pp. 707-716.
	SOMAN, Sadhna et al., "An Experimental study of Video Conferencing over the Internet," IEEE Globecom '94, 1994, pp. 720-724.
	STRIGINI, Lorenzo et al., "Multicast Services on High-Speed Interconnected LANs," High Speed Local Area Networks, 1987, pp. 173-176.
	TANIGAWA, Hiroya et al., Personal Multimedia-Multipoint Teleconference System, 1991, pp. 1127-1134.
	TASSIULAS, Leandros et al., "Dynamic Server Allocation to Parallel Queues with Randomly Varying Connectivity," IEEE Transactions on Information Theory, Mar. 1993, vol. 39, No. 2, pp. 466-478.
	TILLMAN, Matthew A. et al., "SNA and OSI: Three Strategies for Interconnection," Communications of the ACM, Feb. 1990, vol. 33, No. 2, pp. 214-224.

Examiner Signature		Date Considered	
--------------------	--	-----------------	--

*EXAMINER: Initial if reference considered, whether or not citation is in conformance with M.P.E.P. § 609. Draw line through citation if not in conformance and not considered. Include copy of this form with next communication to Applicant.

**SECOND
INFORMATION DISCLOSURE
STATEMENT BY APPLICANT**

(use as many sheets as necessary)

Sheet 9 of 9

In re Reexamination of U.S. Patent No. / Control No.:	5,822,523 / 90/011,033
Issue Date:	October 13, 1998
First Named Inventor	Jeffrey J. Rothschild et al.
Confirmation/Group Art Unit No.	1686 / 3992
Attorney Docket No.	0078494-000001

NON-PATENT LITERATURE DOCUMENTS

Include name of the author (in CAPITAL LETTERS), title of the article (when appropriate), title of the item (book, magazine, journal, serial, symposium, catalog, etc.), date, page(s), volume-issue number(s), publisher, city and/or country where published.

	TURLETTI, Thierry et al., "Videoconferencing on the Internet," IEEE/ACM Transactions on Networking, 1996, pp. 340-351.
	TOPOLCIC, C. (ed.), "Experimental Internet Stream Protocol, version 2 (ST-11)," Network Working Group Request for Comments: 1190, Oct. 1990, 127 pages.
	VENKATESH, D. et al., "Investigation of Web Server Access as a Basis for Designing Video-on-Demand Systems," Proceedings of the International Society for Optical Engineering, Oct. 23-24, 1995, vol. 2617, pp. 2-11.
	WATABE, K. et al., "A Distributed Multiparty Desktop Conferencing System and its Architecture," 1990, pp. 386-393.
	What Is RTP? (visited Jan. 4, 2000) < http://raddist.rad.com/networks/1996/iphone/rtp.htm >, 5 pages.
	WILDE, Erik et al., "Transport-Independent Group and Session Management for Group Communications Platforms," ETT, Jul.-Aug. 1997, vol. 8, No. 4, pp. 409-421.
	WILLEBEEK-LEMAIR, M.H. et al., "Centralized versus Distributed Schemes for Videoconferencing," Proceedings of the Fifth IEEE Computer Society Workshop on Future Trends of Distributed Computing System, Aug. 28-30, 1995, pp. 85-93.
	WOODSIDE, Murray C. et al., "Alternative Software Architectures for Parallel Protocol Execution with Synchronous IPC," IEEE/ACM Transactions on Networking, Apr. 1993, vol. 1, No. 2, pp. 178-186.
	XYLOMENOS, George et al., "IP Multicast for Mobile Hosts," IEEE Communications Magazine, Jan. 1997, pp. 54-58.
	XYLOMENOS, George et al., "IP multicast group management for point-to-point local distribution," Computer Communications, 1998, pp. 1645-1654.
	YEUNG, K.H. et al., "Selective Broadcast Data Distribution Systems," Proceedings of the 15th International Conference on Distributed Computing Systems, 05-30-Jun. 2, 1995, pp. 317-324.
	YUM, Tak-Shing et al., "Video Bandwidth Allocation for Multimedia Teleconferences," IEEE Transactions on Communications, Feb./Mar./Apr. 1995, vol. 43, Nos. 2/3/4, pp. 457-465.
	ZARROS, Panagiotis N. et al., "Interparticipant Synchronization in Real-Time Multimedia Conferencing Using Feedback," IEEE/ACM Transactions on Networking, Apr. 1996, vol. 4, No. 2, pp. 173-180.
	ZARROS, Panagiotis N. et al., "Statistical Synchronization Among Participants in Real-Time Multimedia Conference," Proceedings of the IEEE Symposium on Computers and Communications, Jun. 27-29, 1995, pp. 30-36.
	ZHANG, Lixia et al., "RSVP: A New Resource ReSerVation Protocol," Accepted By IEEE Network Magazine, (date unknown), 22 pages.
	OIKARINEN, J. et al., "Internet Relay Chat Protocol," Networking Group Request for Comments: 1459, 05-1993, < http://www.tuug.org/.sup..about.f/irc/text/rfc1459.txt >, 57 pages.

Examiner Signature	Date Considered
--------------------	-----------------

*EXAMINER: Initial if reference considered, whether or not citation is in conformance with M.P.E.P. § 609. Draw line through citation if not in conformance and not considered. Include copy of this form with next communication to Applicant.

Electronic Acknowledgement Receipt

EFS ID:	8518156
Application Number:	90011033
International Application Number:	
Confirmation Number:	1686
Title of Invention:	SERVER-GROUP MESSAGING SYSTEM FOR INTERACTIVE APPLICATIONS
First Named Inventor/Applicant Name:	5,822,523
Customer Number:	26137
Filer:	Charles F. Wieland III/Christine Becker
Filer Authorized By:	Charles F. Wieland III
Attorney Docket Number:	18830.0003
Receipt Date:	28-SEP-2010
Filing Date:	14-JUN-2010
Time Stamp:	17:39:23
Application Type:	Reexam (Patent Owner)

Payment information:

Submitted with Payment	no
------------------------	----

File Listing:

Document Number	Document Description	File Name	File Size(Bytes)/ Message Digest	Multi Part /.zip	Pages (if appl.)
1	Transmittal Letter	001_2ndIDS.pdf	48517 72827fe919bab2c7d0dd60741f7b97a5c7b2fe38	no	1

Warnings:

Information:

2	Reexam Certificate of Service	001_2ndIDSCertofServ.pdf	17753 36445099b4f547969846178a23314d7b4a dd76d	no	1
Warnings:					
Information:					
3	Information Disclosure Statement (IDS) Filed (SB/08)	001_2ndPTO1449.pdf	985368 eacaa12af9ee72aea965a33770d9cb043f4c 2acc	no	9
Warnings:					
Information:					
This is not an USPTO supplied IDS fillable form					
Total Files Size (in bytes):			1051638		
<p>This Acknowledgement Receipt evidences receipt on the noted date by the USPTO of the indicated documents, characterized by the applicant, and including page counts, where applicable. It serves as evidence of receipt similar to a Post Card, as described in MPEP 503.</p> <p><u>New Applications Under 35 U.S.C. 111</u> If a new application is being filed and the application includes the necessary components for a filing date (see 37 CFR 1.53(b)-(d) and MPEP 506), a Filing Receipt (37 CFR 1.54) will be issued in due course and the date shown on this Acknowledgement Receipt will establish the filing date of the application.</p> <p><u>National Stage of an International Application under 35 U.S.C. 371</u> If a timely submission to enter the national stage of an international application is compliant with the conditions of 35 U.S.C. 371 and other applicable requirements a Form PCT/DO/EO/903 indicating acceptance of the application as a national stage submission under 35 U.S.C. 371 will be issued in addition to the Filing Receipt, in due course.</p> <p><u>New International Application Filed with the USPTO as a Receiving Office</u> If a new international application is being filed and the international application includes the necessary components for an international filing date (see PCT Article 11 and MPEP 1810), a Notification of the International Application Number and of the International Filing Date (Form PCT/RO/105) will be issued in due course, subject to prescriptions concerning national security, and the date shown on this Acknowledgement Receipt will establish the international filing date of the application.</p>					

IN THE UNITED STATES PATENT AND TRADEMARK OFFICE

In re Reexamination of)	MAIL STOP REEXAMINATION
U.S. Patent No. 5,822,523)	Group Art Unit: 3992
Jeffrey J. Rothschild et al.)	Examiner:
Issued: October 13, 1998)	Confirmation No.: 1686
Reexamination Control No.: 90/011,033)	Information Disclosure Statement Under
For: SERVER-GROUP MESSAGING)	37 C.F.R. §§ 1.97, 1.98 and 1.555
SYSTEM FOR INTERACTIVE)	
APPLICATIONS)	

SECOND INFORMATION DISCLOSURE STATEMENT

Commissioner for Patents
P.O. Box 1450
Alexandria, VA 22313-1450

Sir:

The documents cited on the attached form, PTO-1449, are being called to the attention of the Examiner. These documents were made of record in at least one of U.S. Patent Nos. 5,822,523 and 6,226,686. No copies of the documents are being submitted herewith as they were already submitted in at least one of U.S. Patent Nos. 5,822,523 and 6,226,686. It is respectfully requested that the cited documents be expressly considered during the prosecution of this reexamination proceeding, and the documents be made of record therein and appear among the "references cited" on any reexamination certificate to issue therefrom.

Applicant believes that no fee is required for submission of this statement. However, if a fee is required, the Commissioner is authorized to deduce such fee from the undersigned's Deposit Account No. 02-4800. Please deduct any additional fees from, or credit any overpayment to, the above-noted Deposit Account.

Respectfully submitted,

BUCHANAN INGERSOLL & ROONEY PC

Date: September 28, 2010

By:

Charles F. Wieland III
Registration No. 33096

Customer No. 21839
703 836 6620

Buchanan Ingersoll & Rooney PC
Attorneys & Government Relations Professionals

CERTIFICATE OF SERVICE

It is hereby certified by the undersigned that a true copy of the foregoing Second Information Disclosure Statement and PTO-1449 Form(s) were transmitted via U.S. mail to:

NOVAK DRUCE + QUIGG, LLP
1000 Louisiana Street
53rd Floor
Houston, Texas 77002

on this 28th day of September, 2010.

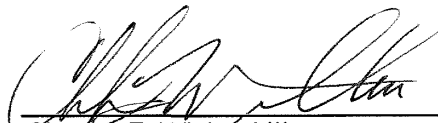

Charles F. Wieland III
Registration No. 33096

IN THE UNITED STATES PATENT AND TRADEMARK OFFICE

In re <i>Ex Parte</i> Reexamination of U.S. Patent of)	MAIL STOP EX PARTE REEXAM
Jeffrey J. Rothschild et al.)	
U.S. Patent No.: 5,822,523)	Art Unit: 3992
Filed: June 14, 2010)	Examiner: Andrew L. Nalven
Control No.: 90/011,033)	Confirmation No.: 1686
For: SERVER-GROUP MESSAGING)	
SYSTEM FOR INTERACTIVE)	
APPLICATIONS)	

APPOINTMENT OF POWER OF ATTORNEY BY ASSIGNEE OF ENTIRE INTEREST AND CHANGE OF CORRESPONDENCE ADDRESS

Commissioner for Patents
P.O. Box 1450
Alexandria, VA 22313-1450

Sir:

The assignee of record of the entire interest of the above-identified U.S. patent hereby appoints the following attorneys to prosecute and transact all business in the U.S. Patent and Trademark Office in connection therewith:

Robert G. Mukai, Registration No. 28,531
Charles F. Wieland III, Registration No. 33,096

Please recognize the correspondence address for the above-identified U.S. patent to the address associated with Customer Number 21839 and direct all calls to Robert G. Mukai at 703-836-6620.

ASSIGNEE STATEMENT UNDER 37 C.F.R. § 3.73(b)

PaTalk Holdings, Inc. hereby states that it is the assignee of the entire right, title and interest in U.S. Patent No. 5,822,523 by virtue of the assignment document recorded on February 11, 2002, at Reel 012598, Frame 0606.

The undersigned, whose title is supplied below, is empowered to sign this statement on behalf of the assignee.

PaTalk Holdings, Inc.

Date: September 7, 2010

By: _____

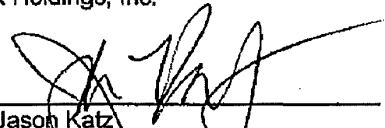

Jason Katz
Chief Executive Officer
500 North Broadway
Jericho, N.Y. 11753

Electronic Acknowledgement Receipt

EFS ID:	8518309
Application Number:	90011033
International Application Number:	
Confirmation Number:	1686
Title of Invention:	SERVER-GROUP MESSAGING SYSTEM FOR INTERACTIVE APPLICATIONS
First Named Inventor/Applicant Name:	5,822,523
Customer Number:	26137
Filer:	Charles F. Wieland III/Christine Becker
Filer Authorized By:	Charles F. Wieland III
Attorney Docket Number:	18830.0003
Receipt Date:	28-SEP-2010
Filing Date:	14-JUN-2010
Time Stamp:	17:49:59
Application Type:	Reexam (Patent Owner)

Payment information:

Submitted with Payment	no
------------------------	----

File Listing:

Document Number	Document Description	File Name	File Size(Bytes)/ Message Digest	Multi Part /.zip	Pages (if appl.)
1	Reexam Change in Pwr Atty for Third Party Requester	001_PowerofAttorney.pdf	41401 <small>6529f9e9f99706e649313c819068938980e256ed</small>	no	1

Warnings:

Information:

This Acknowledgement Receipt evidences receipt on the noted date by the USPTO of the indicated documents, characterized by the applicant, and including page counts, where applicable. It serves as evidence of receipt similar to a Post Card, as described in MPEP 503.

New Applications Under 35 U.S.C. 111

If a new application is being filed and the application includes the necessary components for a filing date (see 37 CFR 1.53(b)-(d) and MPEP 506), a Filing Receipt (37 CFR 1.54) will be issued in due course and the date shown on this Acknowledgement Receipt will establish the filing date of the application.

National Stage of an International Application under 35 U.S.C. 371

If a timely submission to enter the national stage of an international application is compliant with the conditions of 35 U.S.C. 371 and other applicable requirements a Form PCT/DO/EO/903 indicating acceptance of the application as a national stage submission under 35 U.S.C. 371 will be issued in addition to the Filing Receipt, in due course.

New International Application Filed with the USPTO as a Receiving Office

If a new international application is being filed and the international application includes the necessary components for an international filing date (see PCT Article 11 and MPEP 1810), a Notification of the International Application Number and of the International Filing Date (Form PCT/RO/105) will be issued in due course, subject to prescriptions concerning national security, and the date shown on this Acknowledgement Receipt will establish the international filing date of the application.

Electronic Acknowledgement Receipt

EFS ID:	8519151
Application Number:	90011033
International Application Number:	
Confirmation Number:	1686
Title of Invention:	SERVER-GROUP MESSAGING SYSTEM FOR INTERACTIVE APPLICATIONS
First Named Inventor/Applicant Name:	5,822,523
Customer Number:	26137
Filer:	Charles F. Wieland III/Christine Becker
Filer Authorized By:	Charles F. Wieland III
Attorney Docket Number:	18830.0003
Receipt Date:	28-SEP-2010
Filing Date:	14-JUN-2010
Time Stamp:	19:08:17
Application Type:	Reexam (Patent Owner)

Payment information:

Submitted with Payment	no
------------------------	----

File Listing:

Document Number	Document Description	File Name	File Size(Bytes)/ Message Digest	Multi Part /.zip	Pages (if appl.)
1	Foreign Reference	Ref118_EP876.pdf	591232 <small>de9d9d3c5784f18efa563c8d5af630e3d1192397</small>	no	11

Warnings:

Information:

This Acknowledgement Receipt evidences receipt on the noted date by the USPTO of the indicated documents, characterized by the applicant, and including page counts, where applicable. It serves as evidence of receipt similar to a Post Card, as described in MPEP 503.

New Applications Under 35 U.S.C. 111

If a new application is being filed and the application includes the necessary components for a filing date (see 37 CFR 1.53(b)-(d) and MPEP 506), a Filing Receipt (37 CFR 1.54) will be issued in due course and the date shown on this Acknowledgement Receipt will establish the filing date of the application.

National Stage of an International Application under 35 U.S.C. 371

If a timely submission to enter the national stage of an international application is compliant with the conditions of 35 U.S.C. 371 and other applicable requirements a Form PCT/DO/EO/903 indicating acceptance of the application as a national stage submission under 35 U.S.C. 371 will be issued in addition to the Filing Receipt, in due course.

New International Application Filed with the USPTO as a Receiving Office

If a new international application is being filed and the international application includes the necessary components for an international filing date (see PCT Article 11 and MPEP 1810), a Notification of the International Application Number and of the International Filing Date (Form PCT/RO/105) will be issued in due course, subject to prescriptions concerning national security, and the date shown on this Acknowledgement Receipt will establish the international filing date of the application.



UNITED STATES PATENT AND TRADEMARK OFFICE

UNITED STATES DEPARTMENT OF COMMERCE
 United States Patent and Trademark Office
 Address: COMMISSIONER FOR PATENTS
 P.O. Box 1450
 Alexandria, Virginia 22313-1450
 www.uspto.gov



Bib Data Sheet

CONFIRMATION NO. 1686

SERIAL NUMBER 90/011,033	FILING OR 371(c) DATE 06/14/2010 RULE	CLASS 700	GROUP ART UNIT 3992	ATTORNEY DOCKET NO. 18830.0003
------------------------------------	---	---------------------	-------------------------------	--

APPLICANTS
 5,822,523, Residence Not Provided;
 PALTALK HOLDINGS, INC. (OWNER), NEW YORK, NY;
 NOVAK DRUCE & QUIGG LLP (3RD PTY. REQ.), HOUSTON, TX;
 NOVAK DRUCE & QUIGG, LLP, HOUSTON, TX

**** CONTINUING DATA *******
 This application is a REX of 08/595,323 02/01/1996 PAT 5,822,523

**** FOREIGN APPLICATIONS *******

Foreign Priority claimed <input type="checkbox"/> yes <input type="checkbox"/> no	STATE OR COUNTRY	SHEETS DRAWING	TOTAL CLAIMS 6	INDEPENDENT CLAIMS 1
35 USC 119 (a-d) conditions met <input type="checkbox"/> yes <input type="checkbox"/> no <input type="checkbox"/> Met after Allowance				
Verified and Acknowledged	Examiner's Signature	Initials		

ADDRESS
 21839

TITLE
 SERVER-GROUP MESSAGING SYSTEM FOR INTERACTIVE APPLICATIONS

FILING FEE RECEIVED 2520	FEES: Authority has been given in Paper No. _____ to charge/credit DEPOSIT ACCOUNT No. _____ for following:	<input type="checkbox"/> All Fees <input type="checkbox"/> 1.16 Fees (Filing) <input type="checkbox"/> 1.17 Fees (Processing Ext. of time) <input type="checkbox"/> 1.18 Fees (Issue) <input type="checkbox"/> Other _____ <input type="checkbox"/> Credit
------------------------------------	---	---



UNITED STATES PATENT AND TRADEMARK OFFICE

UNITED STATES DEPARTMENT OF COMMERCE
United States Patent and Trademark Office
Address: COMMISSIONER FOR PATENTS
P.O. Box 1450
Alexandria, Virginia 22313-1450
www.uspto.gov

APPLICATION NUMBER	FILING OR 371(C) DATE	FIRST NAMED APPLICANT	ATTY. DOCKET NO./TITLE
90/011,033	06/14/2010	5,822,523	18830.0003

CONFIRMATION NO. 1686

POWER OF ATTORNEY NOTICE

26137
PATENT DEPARTMENT
SKADDEN, ARPS, SLATE, MEAGHER & FLOM LLP
FOUR TIMES SQUARE
NEW YORK, NY 10036



Date Mailed: 09/30/2010

NOTICE REGARDING CHANGE OF POWER OF ATTORNEY

This is in response to the Power of Attorney filed 09/28/2010.

- The Power of Attorney to you in this application has been revoked by the assignee who has intervened as provided by 37 CFR 3.71. Future correspondence will be mailed to the new address of record(37 CFR 1.33).

/jawhitfield/

Office of Data Management, Application Assistance Unit (571) 272-4000, or (571) 272-4200, or 1-888-786-0101



UNITED STATES PATENT AND TRADEMARK OFFICE

UNITED STATES DEPARTMENT OF COMMERCE
United States Patent and Trademark Office
Address: COMMISSIONER FOR PATENTS
P.O. Box 1450
Alexandria, Virginia 22313-1450
www.uspto.gov

APPLICATION NUMBER	FILING OR 371(C) DATE	FIRST NAMED APPLICANT	ATTY. DOCKET NO./TITLE
90/011,033	06/14/2010	5,822,523	18830.0003

21839
BUCHANAN, INGERSOLL & ROONEY PC
POST OFFICE BOX 1404
ALEXANDRIA, VA 22313-1404

CONFIRMATION NO. 1686
POA ACCEPTANCE LETTER



Date Mailed: 09/30/2010

NOTICE OF ACCEPTANCE OF POWER OF ATTORNEY

This is in response to the Power of Attorney filed 09/28/2010.

The Power of Attorney in this application is accepted. Correspondence in this application will be mailed to the above address as provided by 37 CFR 1.33.

/jawhitfield/

Office of Data Management, Application Assistance Unit (571) 272-4000, or (571) 272-4200, or 1-888-786-0101

Substitute for form 1449/PTO & 1449B/PTO THIRD INFORMATION DISCLOSURE STATEMENT BY APPLICANT (use as many sheets as necessary)	<i>Complete if Known</i> <table border="1" style="width:100%; border-collapse: collapse;"> <tr> <td style="width:60%;">In re Reexamination of U.S. Patent No. / Control No.:</td> <td>5,822,523 / 90/011,033</td> </tr> <tr> <td>Issue Date:</td> <td>October 13, 1998</td> </tr> <tr> <td>First Named Inventor</td> <td>Jeffrey J. Rothschild et al.</td> </tr> <tr> <td>Confirmation/Group Art Unit No.</td> <td>1686 / 3992</td> </tr> <tr> <td>Attorney Docket No.</td> <td>0078494-000001</td> </tr> </table>	In re Reexamination of U.S. Patent No. / Control No.:	5,822,523 / 90/011,033	Issue Date:	October 13, 1998	First Named Inventor	Jeffrey J. Rothschild et al.	Confirmation/Group Art Unit No.	1686 / 3992	Attorney Docket No.	0078494-000001
In re Reexamination of U.S. Patent No. / Control No.:	5,822,523 / 90/011,033										
Issue Date:	October 13, 1998										
First Named Inventor	Jeffrey J. Rothschild et al.										
Confirmation/Group Art Unit No.	1686 / 3992										
Attorney Docket No.	0078494-000001										

Sheet 1 of 1

U.S. PATENT DOCUMENTS

Exmr. Initials	Ref. No.	Document Number-Kind Code	Publication/Issue Date MM-DD-YYYY	Name of Patentee or Applicant of Cited Document	Pages, Columns, Lines Where Relevant Passages or Figures Appear

FOREIGN PATENT DOCUMENTS

Exmr. Initials	Ref. No.	Foreign Patent Document		Publication Date (MM-DD-YYYY)	Name of Patentee or Applicant of Cited Document	STATUS								
		Country Code ¹ , Number, Kind Code				Translation	Partial Translation	Eng. Lang. Summary	Search Report	IPER	Abstract	Cited in Spec. / Pg. No(s).		

¹Enter Office that issued the document, by the two-letter code.

NON-PATENT LITERATURE DOCUMENTS

Exmr. Initials	Ref. No.	Include name of the author (in CAPITAL LETTERS), title of the article (when appropriate), title of the item (book, magazine, journal, serial, symposium, catalog, etc.), date, page(s), volume-issue number(s), publisher, city and/or country where published.
		BENNETT, J. et al., "Munin: Distributed Shared Memory Based on Type-Specific Memory Coherence", Proceedings of 2nd ACM SIGPLAN Symposium on PPOPP, 1990, pp. 168-176
		CARTER, J. et al., "Implementation and Performance of Munin", Proceedings of 13th Symposium on Operating System Principles", 1991, pp. 152-164
		COLEMAN, S. et al., "The TCP/IP Internet DOOM FAQ", http://www.gamers.org/dhs/helpdocs/inetdoom.html , August, 1998, pp. 1-10
		COTTON, J. et al., "The TCP/IP Internet Gamer's FAQ", http://x8.dejanews.com/getdoc.xp?AN-1031 , July, 1998, pp. 1-9
		COULOURIS, G. et al., "Distributed Systems: Concepts and Design", Addison-Wesley Publishing Co., 1994, pp. 333-348
		FUNKHOUSER, T., "RING: A Client-Server System for Multi-User Virtual Environments", pp. 1-9
		JAMES, R. et al., "Creating Your Own Multiplayer Game Systems", Dr. Dobb's Information Highway Sourcebook, Winter, 1994, pp. 56-64
		MACEDONIA, M. et al., "MBone Provides Audio and Video Across the Internet", IEEE Computer, Vol. 27, Issue 4, 30-36, April, 1994, pp. 1-12
		MACEDONIA, M. et al., "NPSNET: A Network Software Architecture for Large Scale Virtual Environments", Presence, Vol. 3, No. 4, Fall, 1994, pp. 1-30
		SCHULZRINNE, H. et al., "A Transport Protocol for Real-Time Applications", IETF Internet Draft draft-ietf-avt-rtp-05.txt, 1994, pp. 1-16
		WOLFE, D., "The BBS Construction Kit", 1st Ed., 1994, John Wiley & Sons, Inc., New York, pp. 1-37

Examiner Signature	Date Considered	
--------------------	-----------------	--

*EXAMINER: Initial if reference considered, whether or not citation is in conformance with M.P.E.P. § 609. Draw line through citation if not in conformance and not considered. Include copy of this form with next communication to Applicant.

Electronic Acknowledgement Receipt

EFS ID:	8608240
Application Number:	90011033
International Application Number:	
Confirmation Number:	1686
Title of Invention:	SERVER-GROUP MESSAGING SYSTEM FOR INTERACTIVE APPLICATIONS
First Named Inventor/Applicant Name:	5,822,523
Customer Number:	21839
Filer:	Charles F. Wieland III/Christine Becker
Filer Authorized By:	Charles F. Wieland III
Attorney Docket Number:	18830.0003
Receipt Date:	12-OCT-2010
Filing Date:	14-JUN-2010
Time Stamp:	15:42:10
Application Type:	Reexam (Patent Owner)

Payment information:

Submitted with Payment	no
------------------------	----

File Listing:

Document Number	Document Description	File Name	File Size(Bytes)/ Message Digest	Multi Part /.zip	Pages (if appl.)
1	Transmittal Letter	3rdIDS.pdf	56773 <small>dedde7c7d4c40b5534f1c4e01c4a39e30660fae</small>	no	2

Warnings:

Information:

2	Information Disclosure Statement (IDS) Filed (SB/08)	3rdPTO1449.pdf	88923 90961300bd46b7ec0881999bde57d7dbe87c4735	no	1
Warnings:					
Information:					
This is not an USPTO supplied IDS fillable form					
3	NPL Documents	BENNETT.pdf	991409 a924523870c5118818fe3dcdffbd2ceac815a784	no	9
Warnings:					
Information:					
4	NPL Documents	CARTER.pdf	1807324 1100abe493b7e196470f3b611ef5f08b4af4a2fe	no	13
Warnings:					
Information:					
5	NPL Documents	COLEMAN.pdf	673216 3521594c323754191ebfc7314fa26167a44a3eaf	no	10
Warnings:					
Information:					
6	NPL Documents	COTTON.pdf	597753 3ff6edacf03da28ceb55ce2c5e3a434a575188c67	no	9
Warnings:					
Information:					
7	NPL Documents	COULOURIS.pdf	2212513 dde474a87a781cb5d331d425e549b10c57c20dad	no	16
Warnings:					
Information:					
8	NPL Documents	FUNKHOUSER.pdf	1500492 40a754a56770b791546aa789792f6f217e4db6e8	no	9
Warnings:					
Information:					
9	NPL Documents	JAMES.pdf	1106551 5d5e64202b3a9c3e4bbf9f737199c390fb213e05	no	9
Warnings:					
Information:					
10	NPL Documents	MACEDONIA_MBone.pdf	1283217 8eeda73d0418127925ccf43e58b4f70f958e2a46	no	12

Warnings:					
Information:					
11	NPL Documents	MACEDONIA_NPSNET.pdf	1860112 d190bb00055655c59c380911f36edf92f45a fbcf	no	30
Warnings:					
Information:					
12	NPL Documents	SCHULZRINNE.pdf	715502 2c7c9835c5ce0f4276e5268279acbe27b7e4 f6a9	no	16
Warnings:					
Information:					
13	NPL Documents	WOLFE.pdf	2772828 899868c47518fafa697ff32d9d6342b70862 c13b	no	37
Warnings:					
Information:					
Total Files Size (in bytes):				15666613	
<p>This Acknowledgement Receipt evidences receipt on the noted date by the USPTO of the indicated documents, characterized by the applicant, and including page counts, where applicable. It serves as evidence of receipt similar to a Post Card, as described in MPEP 503.</p> <p><u>New Applications Under 35 U.S.C. 111</u> If a new application is being filed and the application includes the necessary components for a filing date (see 37 CFR 1.53(b)-(d) and MPEP 506), a Filing Receipt (37 CFR 1.54) will be issued in due course and the date shown on this Acknowledgement Receipt will establish the filing date of the application.</p> <p><u>National Stage of an International Application under 35 U.S.C. 371</u> If a timely submission to enter the national stage of an international application is compliant with the conditions of 35 U.S.C. 371 and other applicable requirements a Form PCT/DO/EO/903 indicating acceptance of the application as a national stage submission under 35 U.S.C. 371 will be issued in addition to the Filing Receipt, in due course.</p> <p><u>New International Application Filed with the USPTO as a Receiving Office</u> If a new international application is being filed and the international application includes the necessary components for an international filing date (see PCT Article 11 and MPEP 1810), a Notification of the International Application Number and of the International Filing Date (Form PCT/RO/105) will be issued in due course, subject to prescriptions concerning national security, and the date shown on this Acknowledgement Receipt will establish the international filing date of the application.</p>					

IN THE UNITED STATES PATENT AND TRADEMARK OFFICE

In re Reexamination of)	MAIL STOP REEXAMINATION
U.S. Patent No. 5,822,523)	Group Art Unit: 3992
Jeffrey J. Rothschild et al.)	Examiner:
Issued: October 13, 1998)	Confirmation No.: 1686
Reexamination Control No.: 90/011,033)	Information Disclosure Statement Under
For: SERVER-GROUP MESSAGING)	37 C.F.R. § § 1.97, 1.98 and 1.555
SYSTEM FOR INTERACTIVE)	
APPLICATIONS)	

THIRD INFORMATION DISCLOSURE STATEMENT

Commissioner for Patents
P.O. Box 1450
Alexandria, VA 22313-1450

Sir:

The documents cited on the attached form, PTO-1449, are being called to the attention of the Examiner. These documents were made of record as listed Prior Art in *Paltalk Holdings, Inc. v. Microsoft Corp.*, Civil Action No. 2:06-CV-367 (DF), Microsoft Corp.'s Final Invalidation Contentions, filed on September 10, 2008. The other documents cited in this court filing have already been brought to the Examiner's attention.

Applicant believes that no fee is required for submission of this statement. However, if a fee is required, the Commissioner is authorized to deduct such fee from the undersigned's Deposit Account No. 02-4800.

Respectfully submitted,

BUCHANAN INGERSOLL & ROONEY PC

Date: October 12, 2010

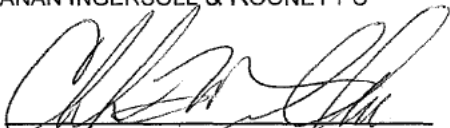
By: 
Charles F. Wieland III
Registration No. 33096

Customer No. 21839
703 836 6620

CERTIFICATE OF SERVICE

It is hereby certified by the undersigned that a true copy of the foregoing Third Information Disclosure Statement and PTO-1449 Form(s) were transmitted via U.S. mail to:

NOVAK DRUCE + QUIGG, LLP
1000 Louisiana Street
53rd Floor
Houston, Texas 77002

on this 12th day of October, 2010.

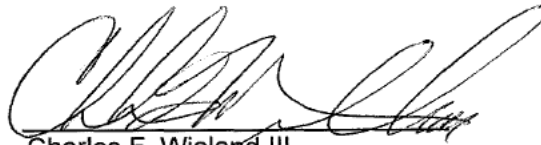

Charles F. Wieland III
Registration No. 33096



UNITED STATES PATENT AND TRADEMARK OFFICE

UNITED STATES DEPARTMENT OF COMMERCE
United States Patent and Trademark Office
Address: COMMISSIONER FOR PATENTS
P.O. Box 1450
Alexandria, Virginia 22313-1450
www.uspto.gov

APPLICATION NO.	FILING DATE	FIRST NAMED INVENTOR	ATTORNEY DOCKET NO.	CONFIRMATION NO.
90/011,033	06/14/2010	5,822,523	18830.0003	1686
21839	7590	12/03/2010	EXAMINER	
BUCHANAN, INGERSOLL & ROONEY PC POST OFFICE BOX 1404 ALEXANDRIA, VA 22313-1404			ART UNIT	PAPER NUMBER

DATE MAILED: 12/03/2010

Please find below and/or attached an Office communication concerning this application or proceeding.



UNITED STATES PATENT AND TRADEMARK OFFICE

Commissioner for Patents
United States Patent and Trademark Office
P.O. Box 1450
Alexandria, VA 22313-1450
www.uspto.gov

DO NOT USE IN PALM PRINTER

(THIRD PARTY REQUESTER'S CORRESPONDENCE ADDRESS)

NOVAK DRUCE & QUIGG, LLP
(NDQ REEXAMINATION GROUP)
1000 LOUISIANA STREET
FIFTY-THIRD FLOOR
HOUSTON, TX 77002

MAILED

DEC 03 2010

CENTRAL REEXAMINATION UNIT

EX PARTE REEXAMINATION COMMUNICATION TRANSMITTAL FORM

REEXAMINATION CONTROL NO. 90/011,033.

PATENT NO. 5,822,523.

ART UNIT 3992.

Enclosed is a copy of the latest communication from the United States Patent and Trademark Office in the above identified *ex parte* reexamination proceeding (37 CFR 1.550(f)).

Where this copy is supplied after the reply by requester, 37 CFR 1.535, or the time for filing a reply has passed, no submission on behalf of the *ex parte* reexamination requester will be acknowledged or considered (37 CFR 1.550(g)).

Office Action in Ex Parte Reexamination	Control No. 90/011,033	Patent Under Reexamination 5,822,523	
	Examiner ANDREW L. NALVEN	Art Unit 3992	

-- The MAILING DATE of this communication appears on the cover sheet with the correspondence address --

- a Responsive to the communication(s) filed on 14 June 2010. b This action is made FINAL.
c A statement under 37 CFR 1.530 has not been received from the patent owner.

A shortened statutory period for response to this action is set to expire _____ month(s) from the mailing date of this letter. Failure to respond within the period for response will result in termination of the proceeding and issuance of an *ex parte* reexamination certificate in accordance with this action. 37 CFR 1.550(d). **EXTENSIONS OF TIME ARE GOVERNED BY 37 CFR 1.550(c)**. If the period for response specified above is less than thirty (30) days, a response within the statutory minimum of thirty (30) days will be considered timely.

Part I THE FOLLOWING ATTACHMENT(S) ARE PART OF THIS ACTION:

- | | |
|---|---|
| 1. <input type="checkbox"/> Notice of References Cited by Examiner, PTO-892. | 3. <input type="checkbox"/> Interview Summary, PTO-474. |
| 2. <input checked="" type="checkbox"/> Information Disclosure Statement, PTO/SB/08. | 4. <input type="checkbox"/> _____. |

Part II SUMMARY OF ACTION

- 1a. Claims 1-6 are subject to reexamination.
 - 1b. Claims _____ are not subject to reexamination.
 2. Claims _____ have been canceled in the present reexamination proceeding.
 3. Claims _____ are patentable and/or confirmed.
 4. Claims 1-6 are rejected.
 5. Claims _____ are objected to.
 6. The drawings, filed on _____ are acceptable.
 7. The proposed drawing correction, filed on _____ has been (7a) approved (7b) disapproved.
 8. Acknowledgment is made of the priority claim under 35 U.S.C. § 119(a)-(d) or (f).
 - a) All b) Some* c) None of the certified copies have
 - 1 been received.
 - 2 not been received.
 - 3 been filed in Application No. _____.
 - 4 been filed in reexamination Control No. _____.
 - 5 been received by the International Bureau in PCT application No. _____.
- * See the attached detailed Office action for a list of the certified copies not received.
9. Since the proceeding appears to be in condition for issuance of an *ex parte* reexamination certificate except for formal matters, prosecution as to the merits is closed in accordance with the practice under *Ex parte* Quayle, 1935 C.D. 11, 453 O.G. 213.
 10. Other: _____

cc: Requester (if third party requester)

DETAILED ACTION

I. Procedures Governing Reexamination

Proposed Amendments, Affidavits, or Declarations

In order to ensure full consideration of any amendments, affidavits or declarations, or other documents as evidence of patentability, such documents must be submitted in response to this Office action. Submissions after the next Office action, which is intended to be a final action, will be governed by the requirements of 37 CFR 1.116, after final rejection and 37 CFR 41.33 after appeal, which will be strictly enforced.

Patent owner is notified that any proposed amendment to the specification and/or claims in this reexamination proceeding must comply with 37 CFR 1.530(d)-(j), must be formally presented pursuant to 37 CFR 1.52(a) and (b), and must contain any fees required by 37 CFR 1.20(c).

Extensions of Time

Extensions of time under 37 CFR 1.136(a) will not be permitted in these proceedings because the provisions of 37 CFR 1.136 apply only to "an applicant" and not to parties in a reexamination proceeding. Additionally, 35 U.S.C. 305 requires that reexamination proceedings "will be conducted with special dispatch" (37 CFR 1.550(a)). Extension of time in *ex parte* reexamination proceedings are provided for in 37 CFR 1.550(c).

Concurrent Litigation

The patent owner is reminded of the continuing responsibility under 37 CFR 1.565(a) to apprise the Office of any litigation activity, or other prior or concurrent proceeding, involving the patent at issue in this reexamination proceeding throughout the course of this reexamination proceeding. The third party requester is also reminded of the ability to similarly apprise the Office of any such activity or proceeding throughout the course of this reexamination proceeding. See MPEP §§ 2207, 2282 and 2286.

II. Summary of the Prosecution and Reexamination Proceeding

The '523 patent was issued on October 13, 1998 from an application filed February 1, 1996. A first office action was issued on March 20, 1997 that rejected claims 1-16. In response, the Applicant canceled claims 1-6 and 13-16 and argued that the cited prior art did not teach or suggest "aggregating payloads of messages." *'523 Patent Prosecution, Remarks submitted 6/9/1997*. The limitations corresponding to the "aggregating" include:

" aggregating, by said server in a time interval determined in accordance with a predefined criterion, said payload portions of said messages to create an aggregated payload; forming an aggregated message using said aggregated payload" *Claim 1*.

Following the amendments and remarks, on July 9, 1997, a notice of allowance was issued that allowed claims 7-12, now patent claims 1-6.

On June 14, 2010, a Third Party Requestor deposited a request for *ex parte* reexamination. This request became the instant reexamination proceeding. Reexamination of claims 1-6 was requested in view of the following prior art patents and publications:

1. Source Code including Server2.5pl4.tar.gz and BRHM-1.3.tar.gz (hereafter "Netrek").
2. RFC 1459 – Internet Relay Chat Protocol by J. Oikarinen, published May 1993 (hereafter "IRC RFC").
3. "Packing Messages as a Tool for Boosting the Performance of Total Ordering Protocols by R. Friedman and published July 7, 1995 (hereafter "Friedman").
4. "An Approach to DIS Scalability" by Van Hook et al and published on September 26-30, 1994 (hereafter "Van Hook").
5. IEEE 1278-1993 IEEE Standard for Information Technology- Protocols for Distributed Interactive Simulation Applications, approved March 18, 1993, and published in 1993 ("DIS")
6. US Patent No. 5,736,982 issued to Suzuki on April 7, 1998 (hereafter "Suzuki") that was not cited in earlier examination. Suzuki qualifies as prior art under §102(e).
7. "RING: A Client-Server System for Multi-User Virtual Environments" by Fukhouser and published April 9-12, 1995 (hereafter "Ring").
8. Andy McFadden, "The History of Netrek", published January 1, 1994 ("McFadden").

Art Unit: 3992

9. Michael R. Macedonia, "Exploiting Reality with Multicast Groups", published September 1995 ("Macedonia").

On July 29, 2010, reexamination was ordered as to claims 1-6.

III. Grounds of Rejection

The following is a quotation of the appropriate paragraphs of 35 U.S.C. 102 that form the basis for the rejections under this section made in this Office action:

A person shall be entitled to a patent unless --

(a) the invention was known or used by others in this country, or patented or described in a printed publication in this or a foreign country, before the invention thereof by the applicant for a patent.

(b) the invention was patented or described in a printed publication in this or a foreign country or in public use or on sale in this country, more than one year prior to the date of application for patent in the United States.

(e) the invention was described in (1) an application for patent, published under section 122(b), by another filed in the United States before the invention by the applicant for patent or (2) a patent granted on an application for patent by another filed in the United States before the invention by the applicant for patent, except that an international application filed under the treaty defined in section 351(a) shall have the effects for purposes of this subsection of an application filed in the United States only if the international application designated the United States and was published under Article 21(2) of such treaty in the English language.

The following is a quotation of 35 U.S.C. 103(a) which forms the basis for all obviousness rejections set forth in this Office action:

(a) A patent may not be obtained though the invention is not identically disclosed or described as set forth in section 102 of this title, if the differences between the subject matter sought to be patented and the prior art are such that the subject matter as a whole would have been obvious at the time the invention was made to a person having ordinary skill in the art to which said subject matter pertains. Patentability shall not be negated by the manner in which the invention was made.

Claims 1-6 are rejected under 35 U.S.C. 103(a) as being obvious over IRC RFC in view of Friedman as detailed below. Further, the proposed rejection of claims 1-6 set forth in the June 14, 2010 request for reexamination in Claim Chart D is incorporated by reference.

With regards to claim 1, IRC RFC teaches a method for providing group messages to a plurality of host computers connected over a unicast wide area communication network (*IRC RFC, §1 and §1.1 – IRC provides text based conferencing among clients by way of a server that forms a central point for communication*),

comprising the steps of: providing a group messaging server coupled to said network, said server communicating with said plurality of host computers using said unicast network (*IRC RFC, §1 and §1.1 – IRC provides text based conferencing among clients by way of a server that forms a central point for communication*)

and maintaining a list of message groups, each message group containing at least one host computer (*IRC RFC, §1.3 – a channel is a named group of one or more clients which will receive all messages addressed to that channel, distributed channels are channels that are known to all servers; §9.2.2 – servers know about all channels including their inhabitants and properties*);

sending, by a plurality of host computers belonging to a first message group, messages to said server via said unicast network, said messages containing a payload portion and a portion for identifying said first message group (*IRC RFC, §4.4.1 – PRIVMSG function used to send a message, receiver parameter may be a channel name and text parameter includes payload text to be sent to channel*) and

and transmitting, by said server via said unicast network, said message to a recipient host computer belonging to said first message group (*IRC RFC, §4.4.1 – PRIVMSG function used to send a message, receiver parameter may be a channel name and text parameter includes*

payload text to be sent to channel; §3.2.2 – messages sent to a channel are sent to each client on the channel).

IRC RFC does not specifically teach the claimed aggregation step. However, Friedman teaches the claimed aggregation step including:

aggregating, by said server in a time interval determined in accordance with a predefined criterion, said payload portions of said messages to create an aggregated payload (*Friedman, Page 5 – Dysfc - messages are buffered and every 1 millisecond they are packed and sent as one packed message*);

forming an aggregated message using said aggregated payload; (*Friedman, Page 5 – Dysfc – packed message is sent*).

At the time the invention was made, it would have been obvious to one of ordinary skill in the art to utilize Friedman's method of aggregating messages because it offers the advantage of drastically increasing the throughput of messages by reducing contention on the network and decreasing the load on receiving processors thus lowering latency (*Friedman, pages 5-6*).

With regards to claim 2, IRC RFC as modified teaches said time interval is a fixed period of time (*Friedman, Page 5 – Dysfc - messages are buffered and every 1 millisecond they are packed and sent as one packed message*).

With regards to claim 3, IRC RFC as modified teaches said time interval corresponds to a time for said server to receive at least one message from each host computer belonging to

Art Unit: 3992

said first message group (*Friedman, Page 5 – Dysfc - messages are buffered and every 1 millisecond they are packed and sent as one packed message*).

With regards to claim 4, IRC RFC as modified teaches creating, by one of said plurality of host computers, said first message group by sending a first control message to said server via said unicast network (*IRC RFC, § 1.3 - "To create a new channel or become part of an existing channel, a user is required to JOIN the channel. If the channel doesn't exist prior to joining, the channel is created and the creating user becomes a channel operator."*; §4.2.1 – *join command is sent by a user in order to join/create a channel*).

With regards to claim 5, IRC RFC as modified teaches the step of joining, by some of said plurality of host computers, said first message group by sending control messages via said unicast network to said server specifying said first message group (*IRC RFC, § 1.3 - "To create a new channel or become part of an existing channel, a user is required to JOIN the channel. If the channel doesn't exist prior to joining, the channel is created and the creating user becomes a channel operator."*; §4.2.1 – *join command is sent by a user in order to join/create a channel*).

With regards to claim 6, IRC RFC as modified teaches network is Internet and said server communicates with said plurality of host computers using a session layer protocol (*IRC RFC, §1 – IRC protocol utilizes TCP/IP network*).

CORRESPONDENCE

All correspondence relating to this ex parte reexamination proceeding should be directed:

By EFS: Registered users may submit via the electronic filing system EFS-Web, at <https://sportal.uspto.gov/authenticate/authenticateuserlocalepf.html>.

By Mail to: Mail Stop *Ex Parte* Reexam
Central Reexamination Unit
Commissioner for Patents
United States Patent & Trademark Office
P.O. Box 1450
Alexandria, VA 22313-1450

By FAX to: (571) 273-9900
Central Reexamination Unit

By hand: Customer Service Window
Randolph Building
401 Dulany Street
Alexandria, VA 22314

For EFS-Web transmissions, 37 CFR 1.8(a)(1)(i) (C) and (ii) states that correspondence (except for a request for reexamination and a corrected or replacement request for reexamination) will be considered timely filed if (a) it is transmitted via the Office's electronic filing system in accordance with 37 CFR 1.6(a)(4), and (b) includes a certificate of transmission for each piece of correspondence stating the date of transmission, which is prior to the expiration of the set period of time in the Office action.

Application/Control Number: 90/011,033

Page 10

Art Unit: 3992

Any inquiry concerning this communication or earlier communications from the Examiner, or as to the status of this proceeding, should be directed to the Central Reexamination Unit at telephone number (571) 272-7705.

Signed:

/Andrew Nalven/

Andrew Nalven
CRU Examiner
GAU 3992
(571) 272-3839

Conferee: ESK

Conferee: HNT

Substitute for form 1449/PTO & 1449B/PTO <div style="text-align: center;">THIRD</div> <div style="text-align: center;">INFORMATION DISCLOSURE</div> <div style="text-align: center;">STATEMENT BY APPLICANT</div> <p style="text-align: center;">(use as many sheets as necessary)</p>	<i>Complete if Known</i> <table border="1" style="width:100%; border-collapse: collapse;"> <tr> <td style="width:50%;">In re Reexamination of U.S. Patent No. / Control No.:</td> <td>5,822,523 / 90/011,033</td> </tr> <tr> <td>Issue Date:</td> <td>October 13, 1998</td> </tr> <tr> <td>First Named Inventor</td> <td>Jeffrey J. Rothschild et al.</td> </tr> <tr> <td>Confirmation/Group Art Unit No.</td> <td>1686 / 3992</td> </tr> <tr> <td>Attorney Docket No.</td> <td>0078494-000001</td> </tr> </table>	In re Reexamination of U.S. Patent No. / Control No.:	5,822,523 / 90/011,033	Issue Date:	October 13, 1998	First Named Inventor	Jeffrey J. Rothschild et al.	Confirmation/Group Art Unit No.	1686 / 3992	Attorney Docket No.	0078494-000001
In re Reexamination of U.S. Patent No. / Control No.:	5,822,523 / 90/011,033										
Issue Date:	October 13, 1998										
First Named Inventor	Jeffrey J. Rothschild et al.										
Confirmation/Group Art Unit No.	1686 / 3992										
Attorney Docket No.	0078494-000001										
Sheet 1 of 1											

U.S. PATENT DOCUMENTS					
Exmr. Initials	Ref. No.	Document Number- Kind Code	Publication/Issue Date MM-DD-YYYY	Name of Patentee or Applicant of Cited Document	Pages, Columns, Lines Where Relevant Passages or Figures Appear

FOREIGN PATENT DOCUMENTS												
Exmr. Initials	Ref. No.	Foreign Patent Document			Name of Patentee or Applicant of Cited Document	STATUS						
		Country Code ¹ , Number, Kind Code	Publication Date (MM-DD-YYYY)			Translation	Partial Translation	Eng. Lang. Summary	Search Report	IPER	Abstract	Cited in Spec. / Pg. No(s).

Enter Office that issued the document, by the two-letter code.

NON-PATENT LITERATURE DOCUMENTS	
Include name of the author (in CAPITAL LETTERS), title of the article (when appropriate), title of the item (book, magazine, journal, serial, symposium, catalog, etc.), date, page(s), volume-issue number(s), publisher, city and/or country where published.	
Exmr. Initials	Ref. No. Include name of the author (in CAPITAL LETTERS), title of the article (when appropriate), title of the item (book, magazine, journal, serial, symposium, catalog, etc.), date, page(s), volume-issue number(s), publisher, city and/or country where published.
	BENNETT, J. et al., "Munin: Distributed Shared Memory Based on Type-Specific Memory Coherence", Proceedings of 2nd ACM SIGPLAN Symposium on PPOPP, 1990, pp. 168-176
	CARTER, J. et al., "Implementation and Performance of Munin", Proceedings of 13th Symposium on Operating System Principles", 1991, pp. 152-164
	COLEMAN, S. et al., "The TCP/IP Internet DOOM FAQ", http://www.gamers.org/dhs/helpdocs/inetdoom.html , August, 1998, pp. 1-10
	COTTON, J. et al., "The TCP/IP Internet Gamer's FAQ", http://x8.dejanews.com/getdoc.xp?AN-1031 , July, 1998, pp. 1-9
	COULOURIS, G. et al., "Distributed Systems: Concepts and Design", Addison-Wesley Publishing Co., 1994, pp. 333-348
	FUNKHOUSER, T., "RING: A Client-Server System for Multi-User Virtual Environments", pp. 1-9
	JAMES, R. et al., "Creating Your Own Multiplayer Game Systems", Dr. Dobb's Information Highway Sourcebook, Winter, 1994, pp. 56-64
	MACEDONIA, M. et al., "MBone Provides Audio and Video Across the Internet", IEEE Computer, Vol. 27, Issue 4, 30-36, April, 1994, pp. 1-12
	MACEDONIA, M. et al., "NPSNET: A Network Software Architecture for Large Scale Virtual Environments", Presence, Vol. 3, No. 4, Fall, 1994, pp. 1-30
	SCHULZRINNE, H. et al., "A Transport Protocol for Real-Time Applications", IETF Internet Draft draft-ietf-avt-rtsp-05.txt, 1994, pp. 1-16
	WOLFE, D., "The BBS Construction Kit", 1st Ed., 1994, John Wiley & Sons, Inc., New York, pp. 1-37

Examiner Signature	/Andrew Nalven/	Date Considered	11/30/2010
--------------------	-----------------	-----------------	------------

*EXAMINER: Initial if reference considered, whether or not citation is in conformance with M.P.E.P. § 609. Draw line through citation if not in conformance and not considered. Include copy of this form with next communication to Applicant.

ALL REFERENCES CONSIDERED EXCEPT WHERE LINED THROUGH. /A.N./

Substitute for form 1449/PTO & 1448B/PTO		Complete if Known	
FIRST INFORMATION DISCLOSURE STATEMENT BY APPLICANT (use as many sheets as necessary)		In re Reexamination of U.S. Patent No. / Control No.:	5,822,523 / 90/011,033
		Issue Date:	October 13, 1998
		First Named Inventor	Jeffrey J. Rothschild et al.
		Confirmation/Group Art Unit No.	1686 / 3992
		Attorney Docket No.	0078494-000001

Sheet 1 of 7

U.S. PATENT DOCUMENTS

Exmr. Initials	Ref. No.	Document Number- Kind Code	Publication/Issue Date MM-DD-YYYY	Name of Patentee or Applicant of Cited Document	Pages, Columns, Lines Where Relevant Passages or Figures Appear
	1	4,479,195	10-23-1984	HERR et al.	
	2	4,558,180	12-10-1985	SCORDO	
	3	5,079,767	01-07-1992	PERLMAN	
	4	5,247,615	09-21-1993	MORI et al.	
	5	5,260,942	11-09-1993	AUERACH et al.	
	6	5,329,619	07-12-1994	PAGÉ et al.	
	7	5,436,896	07-25-1995	ANDERSON et al.	
	8	5,530,699	06-25-1996	KLINE	
	9	5,539,741	07-23-1996	BARRACLOUGH et al.	
	10	5,586,257	12-17-1996	PERLMAN	
	11	5,608,726	03-04-1997	VIRGILE	
	12	5,659,691	08-19-1997	DURWARD et al.	
	13	5,684,800	11-04-1997	DOBBINS et al.	
	14	5,736,982	04-07-1998	SUZUKI et al.	
	15	5,787,085	07-28-1998	FOX	
	16	5,805,823	09-08-1998	SEITZ	
	17	6,041,166	03-21-2000	HART et al.	
	18	6,076,117	06-13-2000	BILLINGS	
	19	6,115,747	09-05-2000	BILLINGS et al.	
	20	6,269,404	07-31-2001	HART et al.	
	21	6,426,954	07-30-2002	KRAUSE	
	22	6,873,627	03-29-2005	MILLER et al.	
	123	5,829,041	10-27-1998	OKAMOTO et al.	
	124	5,841,980	11-24-1998	WATERS et al.	
	125	7,493,558	02-17-2009	LEAHY et al.	
	126	4,572,509	02-25-1986	SITRICK	
	127	5,630,757	05-20-1997	GAGIN et al.	
	128	5,785,630	07-28-1998	BOBICK et al.	
	129	5,890,995	04-06-1999	BOBICK et al.	
	130	5,466,200	11-14-1995	ULRICH et al.	
	131	5,690,582	11-25-1997	ULRICH et al.	
	132	5,598,535	01-28-1997	BRECH et al.	
	133	5,649,103	07-15-1997	DATTA et al.	
	137	6,304,550	10-16-2001	FOX	

Examiner Signature	/Andrew Nalven/	Date Considered	11/30/2010
--------------------	-----------------	-----------------	------------

*EXAMINER: Initial if reference considered, whether or not citation is in conformance with M.P.E.P. § 609. Draw line through citation if not in conformance and not considered. Include copy of this form with next communication to Applicant.

ALL REFERENCES CONSIDERED EXCEPT WHERE LINED THROUGH. /A.N./

**FIRST
INFORMATION DISCLOSURE
STATEMENT BY APPLICANT**

(use as many sheets as necessary)

Sheet 2 of 7

In re Reexamination of U.S. Patent No. / Control No.:	5,822,523 / 90/011,033
Issue Date:	October 13, 1998
First Named Inventor	Jeffrey J. Rothschild et al.
Confirmation/Group Art Unit No.	1686 / 3992
Attorney Docket No.	0078494-000001

FOREIGN PATENT DOCUMENTS

Exmr. Initials	Ref. No.	Foreign Patent Document		Name of Patentee or Applicant of Cited Document	STATUS							
		Country Code ¹ , Number, Kind Code	Publication Date (MM-DD-YYYY)		Translation	Partial Translation	Eng. Lang. Summary	Search Report	IPER	Abstract	Cited in Spec. / Pg. No(s).	
	23	EP 0598969 A1	06-01-1994	IBM CORPORATION							X	
	24	EP 0687088 A2	12-13-1995	MOTOROLA, INC.							X	
	25	EP 0714684 A1	06-05-1996	NET GAME LIMITED							X	
	26	WO 94/24803	10-27-1994	AT&T CORP.								
	27	WO 97/04386	02-06-1997	3COM CORPORATION								
	97	JP 2-2262	01-08-1990	FUJI FACOM CORP.		X					X	
	98	JP 2-192344	07-30-1990	FUJITSU LTD.		X					X	
	99	JP 4-249938	09-04-1992	FUJITSU LTD.		X					X	
	100	JP 5-199257	08-20-1993	NEC CORP.		X					X	
	101	JP 5-219096	08-27-1993	NEC CORP.		X					X	
	102	JP 5-336155	12-17-1993	NEC CORP.		X					X	
	103	JP 6-30041	02-04-1994	ALCATEL NV		X					X	
	104	JP 6-152601	05-31-1994	MATSUSHITA ELECTRIC IND CO. LTD.		X					X	
	105	JP 7-254900	10-03-1995	FUJITSU LTD.		X					X	
	118	EP 0 384 876 B1	08-29-1990	IBM CORPORATION								

¹Enter Office that issued the document, by the two-letter code.

NON-PATENT LITERATURE DOCUMENTS

Include name of the author (in CAPITAL LETTERS), title of the article (when appropriate), title of the item (book, magazine, journal, serial, symposium, catalog, etc.), date, page(s), volume-issue number(s), publisher, city and/or country where published.

Exmr. Initials	Ref. No.	Include name of the author (in CAPITAL LETTERS), title of the article (when appropriate), title of the item (book, magazine, journal, serial, symposium, catalog, etc.), date, page(s), volume-issue number(s), publisher, city and/or country where published.
	28	MACEDONIA, Michael R. et al., "A Taxonomy for Networked Virtual Environments", Immersive Telepresence, pp. 48-56
	29	FUNKHOUSER, Thomas A. "RING: A Client-Server System for Multi-User Virtual Environments", 1995 Symposium on Interactive 3D Graphics, pp. 85-209, Monterey, CA
	30	VAN HOOK, Daniel J. et al., "An Approach to DIS Scalability", 11th DIS Workshop, pp. 1-9, September 26-30, 1994
	31	OIKARINEN, J. et al., "Internet Relay Chat Protocol", Network Working Group, May, 1993, pp. 1-61
	32	IEEE Standard for Information Technology -- Protocols for Distributed Interactive Simulation Applications, IEEE, November 10, 2009, pp. 1-64
	34	ABDEL-WAHAB, Hussein, "Reliable Information Service for Internet Computer Conferencing", IEEE, 1993, pp. 128-142
	35	AMIR, Yair, "Replication Using Group Communication Over a Partitioned Network", Thesis, 1995, pp. 1-95
	36	BANGAY, Shaun, "Parallel Implementation of a Virtual Reality System on a Transputer Architecture", July 1993, pp. 1-128

Examiner Signature	/Andrew Nalven/	Date Considered	11/30/2010
--------------------	-----------------	-----------------	------------

*EXAMINER: Initial if reference considered, whether or not citation is in conformance with M.P.E.P. § 609. Draw line through citation if not in conformance and not considered. Include copy of this form with next communication to Applicant.

ALL REFERENCES CONSIDERED EXCEPT WHERE LINED THROUGH. /A.N./

**FIRST
INFORMATION DISCLOSURE
STATEMENT BY APPLICANT**

(use as many sheets as necessary)

Sheet 3 of 7

In re Reexamination of U.S. Patent No. / Control No.:	5,822,523 / 90/011,033
Issue Date:	October 13, 1998
First Named Inventor	Jeffrey J. Rothschild et al.
Confirmation/Group Art Unit No.	1686 / 3992
Attorney Docket No.	0078494-000001

NON-PATENT LITERATURE DOCUMENTS

Include name of the author (in CAPITAL LETTERS), title of the article (when appropriate), title of the item (book, magazine, journal, serial, symposium, catalog, etc.), date, page(s), volume-issue number(s), publisher, city and/or country where published.

37	BRUTZMAN, Donald P., "A Virtual World for an Autonomous Underwater Vehicle", Dissertation, December, 1994, pp. 1-293
38	BRUTZMAN, Donald P. et al., "Internetwork Infrastructure Requirements for Virtual Environments", Naval Postgraduate School, pp. 1-11
39	CALVIN, James O. et al., "Stow Realtime Information Transfer and Networking System Architecture", Twelfth Workshop on Standards for the Interoperability of Distributed Simulations", March 13-17, 1995, pp. 1-11
40	CHERITON, David R. et al., "Distributed Process Groups in the V Kernel", ACM Transactions on Computer Systems, Vol. 3, No. 2, May 1985, pp. 77-107
41	CURTIS, Pavel et al., "MUDs Grow Up: Social Virtual Reality in the Real World", Xerox PARC, January 19, 1993, pp. 1-6
42	SANDERS, Robert M. et al., "The Xpress Transfer Protocol (XTP) A Tutorial (Expanded Version), NASA Johnson Space Center, Engineering directorate, Flight Data Systems Division, University of Houston - Clear Lake, January 1990, pp. 1-78
43	DUVVUR, Prasanth, "Managing Data on the World Wide Web "State of the Art Survey of Innovative Tools and Techniques", Massachusetts Institute of Technology, September, 1995, pp. 1-102
44	ELLIS, Clarence A. "A Model and Algorithm for Concurrent Access Within Groupware", University of Colorado at Boulder, Department of Computer Science, April 1992, pp. 0-34
45	EVARD, Remy, "Collaborative Networked Communication: MUDs as Systems Tools", Northeastern University, Monterey, California, November 1-5, 1993, pp. 1-8
46	FRIEDMAN, Roy et al., "Packing Messages as a Tool for Boosting the Performance of Total Ordering Protocols", Cornell University, July 7, 1995, pp. 0-17
47	GAJEWSKA, Hania et al., "Argo: A System for Distributed Collaboration", Digital Equipment Corporation, pp. 1-8
48	GAUDET, Stuart S., "Dynamic Project Collaboration and Control Using the World Wide Web", Massachusetts Institute of Technology, October 1995, pp. 1-225
49	GOLDING, Richard Andrew, "Weak-consistency group communication and membership", Dissertation, December 1992, pp. 1-165
51	GREENHALGH, Chris et al., "MASSIVE: a Distributed Virtual Reality System Incorporating Spatial Trading", IEEE, 1995, pp. 27-34
52	HOFMANN, Markus, "A Generic Concept for Large-Scale Multicast", Proceedings of International Zurich Seminar on Digital Communications, Zurich, Switzerland, Springer Verlag, February 1996, pp. 1-12
53	JABI, Wassim M. et al., "Beyond the Shared Whiteboard: Issues in Computer Supported Collaborative Design", Proceedings of CAAD Future '95: The Sixth International Conference on Computer-Aided Architectural Design Futures, September 24-26, 1995, Singapore, pp. 1-9
54	KAASHOEK, M.F., "Group Communication in Distributed Computer Systems", Vrije Universiteit, Amsterdam, The Netherlands, 1992, pp. 1-220
55	KAASHOEK, M. Frans, "Efficient Reliable Group Communication for Distributed Systems", Vrije Universiteit, Amsterdam, The Netherlands, 1992, pp. 1-51
56	MACEDONIA, Michael R., "A Network Software Architecture for Large Scale Virtual Environments", Dissertation, June 1995, pp. 1-200
57	MACEDONIA, Michael R. et al., "Exploiting Reality with Multicast Groups: A Network Architecture for Large-Scale Virtual Environments", Naval Postgraduate School, IEEE, 1995, pp. 2-10
58	MILLER, Duncan C. MILLER, Sc.D., "Network Performance Requirements for Real-Time Distributed Simulation", Proc. INET, 1994, pp. 241-1 - 241-8
60	PULLEN, J. Mark, "Networking for Distributed Virtual Simulation", Proc. INET, 1994, pp. 243-1 - 243-7

Examiner Signature	/Andrew Nalven/	Date Considered	11/30/2010
--------------------	-----------------	-----------------	------------

*EXAMINER: Initial if reference considered, whether or not citation is in conformance with M.P.E.P. § 609. Draw line through citation if not in conformance and not considered. Include copy of this form with next communication to Applicant.

ALL REFERENCES CONSIDERED EXCEPT WHERE LINED THROUGH. /A.N./

**FIRST
INFORMATION DISCLOSURE
STATEMENT BY APPLICANT**

(use as many sheets as necessary)

Sheet 4 of 7

In re Reexamination of U.S. Patent No. / Control No.:	5,822,523 / 90/011,033
Issue Date:	October 13, 1998
First Named Inventor	Jeffrey J. Rothschild et al.
Confirmation/Group Art Unit No.	1686 / 3992
Attorney Docket No.	0078494-000001

NON-PATENT LITERATURE DOCUMENTS

Include name of the author (in CAPITAL LETTERS), title of the article (when appropriate), title of the item (book, magazine, journal, serial, symposium, catalog, etc.), date, page(s), volume-issue number(s), publisher, city and/or country where published.

61	SDINGH, Gurinder, "BrickNet: A Software Toolkit for Network-Based Virtual Worlds", The Massachusetts Institute of Technology, Presence, Vol. 3, No. 1, Winter 1994, pp. 19-35
62	SRINIVAS, Kankanahalli et al., "MONET: A Multi-media System for Conferencing and Application Sharing in Distributed Systems", CERC Technical Report Series, Research Note, Concurrent Engineering Research Center, West Virginia University, February 1992, pp. 1-19
63	KAASHOEK, M. Frans et al., "Group communication in Amoeba and its applications", The British Computer Society, The Institution of Electrical Engineers and IOP Publishing Ltd., 1993, pp. 48-58
64	VAN RENESSE, Robert et al., "Design and Performance of Horus: A Lightweight Group Communications System", Department of Computer Science, Cornell University, pp. 1-18
65	VAN RENESSE, Robert et al., "Reliable Multicast Between Microkernels", Computer Science Department, Cornell University, USENIX Association, April 27-28, 1992, pp. 267-283
66	FEINER, Steven et al., "A Virtual World for Network Management", 1993 IEEE, October 18-22, 1993, Seattle, WA, pp. 55-61
67	CRABTREE, R.P., "Job networking", IBM Systems J, Vol. 17, No. 3, 1978, pp. 206-220
68	NAGLE, John, "Congestion Control in IP/TCP Internetworks", Computer Communication Review, ACM SIGCOMM, pp. 1-9
69	NAGLE, John, "Congestion Control in IP/TCP Internetworks", Network Working Group, Request for Comments: 896, January 6, 1984, pp. 1-9
71	BARTLE, Dr. Richard, "Interactive Multi-User Computer Games", British Telecom plc., December, 1990, pp. 1-152
72	EPPINGER, Jeffrey L. et al., "Camelot and Avalon, A Distributed Transaction Facility", pp. 1-43
73	GETTYS, Jin et al., "Volume One: Xlib Programming Manual for Version 11 of the X Window System", O'Reilly & Associates, Inc., 1992, pp. 1-513
74	BACON, David F. et al., "Compiler Transformations for High-Performance Computing", Computer Science Division, University of California, Berkeley, CA, pp. 1-79
75	KAZMAN, Rick, "Making WAVES: On the Design of Architectures for Low-end Distributed Virtual Environments", Department of Computer Science, University of Waterloo, 1993 IEEE, pp. 442-449
76	SHAW, Chris et al., "The MR Toolkit Peers Package and Experiment", Department of Computing Science, University of Alberta, July 14, 1994, IEEE, pp. 1-8
77	TIERNAN, T.R., "Synthetic Theater of War - Europe (STOW-E) Final Report", Naval Command, Control and Ocean Surveillance Center, Technical Report 1700, January 1995, San Diego, CA, pp. 1-77
78	HIRANANDANI, Seema et al., "Evaluating Compiler Optimizations for Fortran D", Research Report, pp. 1-40
79	ANDRÉ, Françoise et al., "The Pandore Compiler: Overview and Experimental Results", IRISA, Publication No. 869, October 1994, pp. 1-26
80	BANERJEE, Prithviraj et al., "The PARADIGM Compiler for Distributed-Memory Message Passing Multicomputers", First International Workshop on Parallel Processing, Bangalore, India, December 1994, pp. 1-9
81	WANG, Qunjie et al., "EM - An Environment Manager for Building Networked Virtual Environments", 1995 IEEE, pp. 11-18
82	SINGH, Gurinder et al., "BrickNet: Sharing Object Behaviors on the Net", Institute of Systems Science, 1995 IEEE, pp. 19-25
83	BROLL, Wolfgang, "Interacting in Distributed Collaborative Virtual Environments", "Institute for Applied Information Technology, German National Research Center for Computer Science (GMD), 1995 IEEE, pp. 148-155

Examiner Signature	/Andrew Nalven/	Date Considered	11/30/2010
--------------------	-----------------	-----------------	------------

*EXAMINER: Initial if reference considered, whether or not citation is in conformance with M.P.E.P. § 609. Draw line through citation if not in conformance and not considered. Include copy of this form with next communication to Applicant.

ALL REFERENCES CONSIDERED EXCEPT WHERE LINED THROUGH. /A.N./

FIRST
INFORMATION DISCLOSURE
STATEMENT BY APPLICANT

(use as many sheets as necessary)

Sheet 5 of 7

In re Reexamination of U.S. Patent No. / Control No.:	5,822,523 / 90/011,033
Issue Date:	October 13, 1998
First Named Inventor	Jeffrey J. Rothschild et al.
Confirmation/Group Art Unit No.	1686 / 3992
Attorney Docket No.	0078494-000001

NON-PATENT LITERATURE DOCUMENTS

Include name of the author (in CAPITAL LETTERS), title of the article (when appropriate), title of the item (book, magazine, journal, serial, symposium, catalog, etc.), date, page(s), volume-issue number(s), publisher, city and/or country where published.

84	MAXFIELD, John et al., "A Distributed Virtual Environment for Concurrent Engineering", The Keyworth Institute of Manufacturing and Information Systems Engineering, Virtual Working Environments Laboratory, School of Computer Studies, The University of Leeds, United Kingdom, 1995 IEEE, pp. 162-170
85	ZYDA, Michael J., "Networked Virtual Environments", Computer Science Department, Naval Postgraduate School, "1995 IEEE, pp. 230-231
86	WEN, Chih-Po, "Portable Library Support for Irregular Applications", Dissertation, University of California at Berkeley, 1995, pp. 1-134
87	YELICK, Katherine et al., "Parallel Data Structure for Symbolic Computation", University of Berkeley, Computer Science Division, Parallel Symbolic Languages and Systems, October 1995, pp. 1-17
88	WEN, Chih-Po et al., "Portable Runtime Support for Asynchronous Simulation", Computer Science Division, University of California, International Conference on Parallel Processing, 1995, pp. 1-10
89	ITSUKI, Noda, "Soccer Server: a simulator of RoboCup", pp. 1-6
92	WANG, Qunjie, "Networked Virtual Reality", Thesis, University of Alberta, pp. 1-108
96	MACEDONIA, Michael R. et al., "NPSNET: A MULTI-PLAYER 3D VIRTUAL ENVIRONMENT OVER THE INTERNET", 1995 Symposium on Interactive 3D Graphics, Monterey, CA, pp. 93, 94 and 210
107	VIN, Harrick M. et al., "Hierarchical Conferencing Architectures for Inter-Group Multimedia Collaboration", Multimedia Laboratory, Department of Computer Science and Engineering, University of California at San Diego, pp. 43-54, 1991 ACM
108	KEUNE, C. M. et al., "Synthetic Theater of War-Europe (STOW-E) Technical Analysis", Technical Report 1703, August 1995, pp. 1-75
109	RANGAN, P. VENKAT et al., "Communication Architectures and Algorithms for Media Mixing in Multimedia Conferences", IEEE/ACM Transactions on Networking, Vol. 1., No. 1, February 1993, pp. 20-30
110	GONG, Fengmin, "Multipoint Audio and Video Control for Packet-Based Multimedia Conference", MCNC Information Technologies, 1994 ACM, pp. 425-432
111	KOSTRIVAS, John, "Design and Implementation of a Membership Server and Its Application Interface", Thesis, U.S. Navy, Naval Postgraduate School, Monterey, CA, March 10, 1995, pp. 1-74
112	SHAW, V. et al., "A Distributed Multimedia System for Application and Communications", School of Applied Science, Nanyang Technological University, Singapore, 1995 IEEE, pp. 221-229
113	HERDMAN, ROGER C., "Distributed Interactive Simulation of Combat", U.S. Government Printing Office, September 1995, pp. 1-83
114	ZIEGLER, Chaim et al., "Multimedia Conferencing on Local Area Networks", Brooklyn College, 1990 IEEE, pp. 52-61
115	SINGH, Gurminder et al., "Networked Virtual Worlds", Institute of Science Science, National University of Singapore, 1995 IEEE, pp. 44-49
116-117	CHOUDHARY, Alok N. et al., "Proceedings of the 1993 International Conference on Parallel Processing", The Pennsylvania State University, Vol. 11 Software, August 16-20, 1993, CRC Press, Inc., pp. 1-33
120	MALONI, Kelly et al., Net games, Your Guide to the Games People Play on the Electronic Highway", Random House, pp. 1-6
121	SHAH, Rawn et al., "Playing Wargames on the Internet", Complete guide to Empire, Galactic, and Netrek, pp. 1-30
134	ABDEL-WAHAB, H.M., "Multiuser tools architecture for group collaboration in computer networks", Department of Computer Science, Old Dominion University, VA, Vol. 13, No. 3, April 1990, pp. 165-169, Butterworth & Co. Ltd.
135	WATERS, Gill et al., "Three-party talk facility on a computer network", Department of Electronic Systems Engineering, University of Essex, UK, vol. 10, No. 3, June 1987, pp. 115-120

Examiner Signature	/Andrew Nalven/	Date Considered	11/30/2010
--------------------	-----------------	-----------------	------------

*EXAMINER: Initial if reference considered, whether or not citation is in conformance with M.P.E.P. § 609. Draw line through citation if not in conformance and not considered. Include copy of this form with next communication to Applicant.

ALL REFERENCES CONSIDERED EXCEPT WHERE LINED THROUGH. /A.N./

Substitute for form 1449/PTO & 1449B/PTO <p style="text-align: center;">FIRST</p> <p style="text-align: center;">INFORMATION DISCLOSURE STATEMENT BY APPLICANT</p> <p style="text-align: center;">(use as many sheets as necessary)</p> <p>Sheet 6 of 7</p>	<i>Complete if Known</i> <table border="1" style="width: 100%; border-collapse: collapse;"> <tr> <td style="width: 50%;">In re Reexamination of U.S. Patent No. / Control No.:</td> <td>5,822,523 / 90/011,033</td> </tr> <tr> <td>Issue Date:</td> <td>October 13, 1998</td> </tr> <tr> <td>First Named Inventor</td> <td>Jeffrey J. Rothschild et al.</td> </tr> <tr> <td>Confirmation/Group Art Unit No.</td> <td>1686 / 3992</td> </tr> <tr> <td>Attorney Docket No.</td> <td>0078494-000001</td> </tr> </table>	In re Reexamination of U.S. Patent No. / Control No.:	5,822,523 / 90/011,033	Issue Date:	October 13, 1998	First Named Inventor	Jeffrey J. Rothschild et al.	Confirmation/Group Art Unit No.	1686 / 3992	Attorney Docket No.	0078494-000001
In re Reexamination of U.S. Patent No. / Control No.:	5,822,523 / 90/011,033										
Issue Date:	October 13, 1998										
First Named Inventor	Jeffrey J. Rothschild et al.										
Confirmation/Group Art Unit No.	1686 / 3992										
Attorney Docket No.	0078494-000001										

NON-PATENT LITERATURE DOCUMENTS	
Include name of the author (in CAPITAL LETTERS), title of the article (when appropriate), title of the item (book, magazine, journal, serial, symposium, catalog, etc.), date, page(s), volume-issue number(s), publisher, city and/or country where published.	
136	HODEL, HORST, "Multicast-Routing - Grundlage des Multimedia-Conferencing im Internet", Bulletin SEV/VSE, 17/96, pp. 17-22, 3 and 65
138	BLANCHARD, Chuck et al., "What's Net in Reality Built for Two", Proceedings of the ACM Snowbird Conference, February 1990, pp. 1-6
139	MCFADDEN, Andy, "UDP client, the wave of the future", E-mail, http://www.cs.cmu.edu/afs/cs.cmu.edu/.../udp , March 8, 1992, pp. 1-18
145	FLINN, Kelton et al., "Super VGA Air Warrior", Flight Manual, pp. 1-147
146	SNOSWELL, Michael, "Overview of Cyberterm, a Cyberspace Protocol Implementation, pp. 1-12
147	BENEDIKT, Michael, "Cyberspace: First Steps, MIT Press, London, England, pp. 1-35

Examiner Signature	/Andrew Nalven/	Date Considered	11/30/2010
--------------------	-----------------	-----------------	------------

*EXAMINER: Initial if reference considered, whether or not citation is in conformance with M.P.E.P. § 609. Draw line through citation if not in conformance and not considered. Include copy of this form with next communication to Applicant.

ALL REFERENCES CONSIDERED EXCEPT WHERE LINED THROUGH. /A.N./

Reexamination 	Application/Control No. 90/011,033	Applicant(s)/Patent Under Reexamination 5,822,523
	Certificate Date	Certificate Number

Requester Correspondence Address: <input type="checkbox"/> Patent Owner <input checked="" type="checkbox"/> Third Party
NOVAK DRUCE & QUIGG, LLP (NDQ REEXAMINATION GROUP) 1000 LOUISIANA STREET FIFTY-THIRD FLOOR HOUSTON, TX 77002

LITIGATION REVIEW <input checked="" type="checkbox"/>	aln <small>(examiner initials)</small>	7/21/10 <small>(date)</small>
Case Name		Director Initials
Paltalk v Sony - 2:09CV274 - OPEN		<i>Eric Heard</i>
2:06CV367 - CLOSED		<i>RY</i>
3:99CV4506 - CLOSED		↓

COPENDING OFFICE PROCEEDINGS	
TYPE OF PROCEEDING	NUMBER
1. none	
2.	
3.	
4.	



UNITED STATES PATENT AND TRADEMARK OFFICE

UNITED STATES DEPARTMENT OF COMMERCE
United States Patent and Trademark Office
Address: COMMISSIONER FOR PATENTS
P.O. Box 1450
Alexandria, Virginia 22313-1450
www.uspto.gov

APPLICATION NO.	FILING DATE	FIRST NAMED INVENTOR	ATTORNEY DOCKET NO.	CONFIRMATION NO.
90/011,033	06/14/2010	5,822,523	18830.0003	1686
21839	7590	12/03/2010	EXAMINER	
BUCHANAN, INGERSOLL & ROONEY PC POST OFFICE BOX 1404 ALEXANDRIA, VA 22313-1404			ART UNIT	PAPER NUMBER

DATE MAILED: 12/03/2010

Please find below and/or attached an Office communication concerning this application or proceeding.



UNITED STATES PATENT AND TRADEMARK OFFICE

Commissioner for Patents
United States Patent and Trademark Office
P.O. Box 1450
Alexandria, VA 22313-1450
www.uspto.gov

DO NOT USE IN PALM PRINTER

MAILED

(THIRD PARTY REQUESTER'S CORRESPONDENCE ADDRESS)

DEC 03 2010

NOVAK DRUCE & QUIGG, LLP
(NDQ REEXAMINATION GROUP)
1000 LOUISIANA STREET
FIFTY-THIRD FLOOR
HOUSTON, TX 77002

CENTRAL REEXAMINATION UNIT

EX PARTE REEXAMINATION COMMUNICATION TRANSMITTAL FORM

REEXAMINATION CONTROL NO. 90/011,033.

PATENT NO. 5,822,523.

ART UNIT 3992.

Enclosed is a copy of the latest communication from the United States Patent and Trademark Office in the above identified *ex parte* reexamination proceeding (37 CFR 1.550(f)).

Where this copy is supplied after the reply by requester, 37 CFR 1.535, or the time for filing a reply has passed, no submission on behalf of the *ex parte* reexamination requester will be acknowledged or considered (37 CFR 1.550(g)).

PTOL-465 (Rev.07-04)

Office Action in Ex Parte Reexamination	Control No. 90/011,033	Patent Under Reexamination 5,822,523	
	Examiner ANDREW L. NALVEN	Art Unit 3992	

-- The MAILING DATE of this communication appears on the cover sheet with the correspondence address --

- a Responsive to the communication(s) filed on 14 June 2010. b This action is made FINAL.
c A statement under 37 CFR 1.530 has not been received from the patent owner.

A shortened statutory period for response to this action is set to expire 2^{mo} month(s) from the mailing date of this letter. Failure to respond within the period for response will result in termination of the proceeding and issuance of an *ex parte* reexamination certificate in accordance with this action. 37 CFR 1.550(d). **EXTENSIONS OF TIME ARE GOVERNED BY 37 CFR 1.550(c).** If the period for response specified above is less than thirty (30) days, a response within the statutory minimum of thirty (30) days will be considered timely.

Part I THE FOLLOWING ATTACHMENT(S) ARE PART OF THIS ACTION:

- | | |
|---|---|
| 1. <input type="checkbox"/> Notice of References Cited by Examiner, PTO-892. | 3. <input type="checkbox"/> Interview Summary, PTO-474. |
| 2. <input checked="" type="checkbox"/> Information Disclosure Statement, PTO/SB/08. | 4. <input type="checkbox"/> _____. |

Part II SUMMARY OF ACTION

- 1a. Claims 1-6 are subject to reexamination.
1b. Claims _____ are not subject to reexamination.
2. Claims _____ have been canceled in the present reexamination proceeding.
3. Claims _____ are patentable and/or confirmed.
4. Claims 1-6 are rejected.
5. Claims _____ are objected to.
6. The drawings, filed on _____ are acceptable.
7. The proposed drawing correction, filed on _____ has been (7a) approved (7b) disapproved.
8. Acknowledgment is made of the priority claim under 35 U.S.C. § 119(a)-(d) or (f).
a) All b) Some* c) None of the certified copies have
1 been received.
2 not been received.
3 been filed in Application No. _____
4 been filed in reexamination Control No. _____
5 been received by the International Bureau in PCT application No. _____
* See the attached detailed Office action for a list of the certified copies not received.
9. Since the proceeding appears to be in condition for issuance of an *ex parte* reexamination certificate except for formal matters, prosecution as to the merits is closed in accordance with the practice under *Ex parte* Quayle, 1935 C.D. 11, 453 O.G. 213.
10. Other: _____

cc: Requester (if third party requester)

DETAILED ACTION

I. Procedures Governing Reexamination

Proposed Amendments, Affidavits, or Declarations

In order to ensure full consideration of any amendments, affidavits or declarations, or other documents as evidence of patentability, such documents must be submitted in response to this Office action. Submissions after the next Office action, which is intended to be a final action, will be governed by the requirements of 37 CFR 1.116, after final rejection and 37 CFR 41.33 after appeal, which will be strictly enforced.

Patent owner is notified that any proposed amendment to the specification and/or claims in this reexamination proceeding must comply with 37 CFR 1.530(d)-(j), must be formally presented pursuant to 37 CFR 1.52(a) and (b), and must contain any fees required by 37 CFR 1.20(c).

Extensions of Time

Extensions of time under 37 CFR 1.136(a) will not be permitted in these proceedings because the provisions of 37 CFR 1.136 apply only to "an applicant" and not to parties in a reexamination proceeding. Additionally, 35 U.S.C. 305 requires that reexamination proceedings "will be conducted with special dispatch" (37 CFR 1.550(a)). Extension of time in *ex parte* reexamination proceedings are provided for in 37 CFR 1.550(c).

Concurrent Litigation

The patent owner is reminded of the continuing responsibility under 37 CFR 1.565(a) to apprise the Office of any litigation activity, or other prior or concurrent proceeding, involving the patent at issue in this reexamination proceeding throughout the course of this reexamination proceeding. The third party requester is also reminded of the ability to similarly apprise the Office of any such activity or proceeding throughout the course of this reexamination proceeding. See MPEP §§ 2207, 2282 and 2286.

II. Summary of the Prosecution and Reexamination Proceeding

The '523 patent was issued on October 13, 1998 from an application filed February 1, 1996. A first office action was issued on March 20, 1997 that rejected claims 1-16. In response, the Applicant canceled claims 1-6 and 13-16 and argued that the cited prior art did not teach or suggest "aggregating payloads of messages." *'523 Patent Prosecution, Remarks submitted 6/9/1997*. The limitations corresponding to the "aggregating" include:

" aggregating, by said server in a time interval determined in accordance with a predefined criterion, said payload portions of said messages to create an aggregated payload; forming an aggregated message using said aggregated payload" *Claim 1*.

Following the amendments and remarks, on July 9, 1997, a notice of allowance was issued that allowed claims 7-12, now patent claims 1-6.

On June 14, 2010, a Third Party Requestor deposited a request for *ex parte* reexamination. This request became the instant reexamination proceeding. Reexamination of claims 1-6 was requested in view of the following prior art patents and publications:

1. Source Code including Server2.5pl4.tar.gz and BRHM-1.3.tar.gz (hereafter "Netrek").
2. RFC 1459 – Internet Relay Chat Protocol by J. Oikarinen, published May 1993 (hereafter "IRC RFC").
3. "Packing Messages as a Tool for Boosting the Performance of Total Ordering Protocols by R. Friedman and published July 7, 1995 (hereafter "Friedman").
4. "An Approach to DIS Scalability" by Van Hook et al and published on September 26-30, 1994 (hereafter "Van Hook").
5. IEEE 1278-1993 IEEE Standard for Information Technology- Protocols for Distributed Interactive Simulation Applications, approved March 18, 1993, and published in 1993 ("DIS")
6. US Patent No. 5,736,982 issued to Suzuki on April 7, 1998 (hereafter "Suzuki") that was not cited in earlier examination. Suzuki qualifies as prior art under §102(e).
7. "RING: A Client-Server System for Multi-User Virtual Environments" by Fuhouser and published April 9-12, 1995 (hereafter "Ring").
8. Andy McFadden, "The History of Netrek", published January 1, 1994 ("McFadden").

9. Michael R. Macedonia, "Exploiting Reality with Multicast Groups", published September 1995 ("Macedonia").

On July 29, 2010, reexamination was ordered as to claims 1-6.

III. Grounds of Rejection

The following is a quotation of the appropriate paragraphs of 35 U.S.C. 102 that form the basis for the rejections under this section made in this Office action:

A person shall be entitled to a patent unless –

(a) the invention was known or used by others in this country, or patented or described in a printed publication in this or a foreign country, before the invention thereof by the applicant for a patent.

(b) the invention was patented or described in a printed publication in this or a foreign country or in public use or on sale in this country, more than one year prior to the date of application for patent in the United States.

(e) the invention was described in (1) an application for patent, published under section 122(b), by another filed in the United States before the invention by the applicant for patent or (2) a patent granted on an application for patent by another filed in the United States before the invention by the applicant for patent, except that an international application filed under the treaty defined in section 351(a) shall have the effects for purposes of this subsection of an application filed in the United States only if the international application designated the United States and was published under Article 21(2) of such treaty in the English language.

The following is a quotation of 35 U.S.C. 103(a) which forms the basis for all obviousness rejections set forth in this Office action:

(a) A patent may not be obtained though the invention is not identically disclosed or described as set forth in section 102 of this title, if the differences between the subject matter sought to be patented and the prior art are such that the subject matter as a whole would have been obvious at the time the invention was made to a person having ordinary skill in the art to which said subject matter pertains. Patentability shall not be negated by the manner in which the invention was made.

Claims 1-6 are rejected under 35 U.S.C. 103(a) as being obvious over IRC RFC in view of Friedman as detailed below. Further, the proposed rejection of claims 1-6 set forth in the June 14, 2010 request for reexamination in Claim Chart D is incorporated by reference.

Art Unit: 3992

With regards to claim 1, IRC RFC teaches a method for providing group messages to a plurality of host computers connected over a unicast wide area communication network (*IRC RFC, §1 and §1.1 – IRC provides text based conferencing among clients by way of a server that forms a central point for communication*),

comprising the steps of: providing a group messaging server coupled to said network, said server communicating with said plurality of host computers using said unicast network (*IRC RFC, §1 and §1.1 – IRC provides text based conferencing among clients by way of a server that forms a central point for communication*)

and maintaining a list of message groups, each message group containing at least one host computer (*IRC RFC, §1.3 – a channel is a named group of one or more clients which will receive all messages addressed to that channel, distributed channels are channels that are known to all servers; §9.2.2 – servers know about all channels including their inhabitants and properties*);

sending, by a plurality of host computers belonging to a first message group, messages to said server via said unicast network, said messages containing a payload portion and a portion for identifying said first message group (*IRC RFC, §4.4.1 – PRIVMSG function used to send a message, receiver parameter may be a channel name and text parameter includes payload text to be sent to channel*) and

and transmitting, by said server via said unicast network, said message to a recipient host computer belonging to said first message group (*IRC RFC, §4.4.1 – PRIVMSG function used to send a message, receiver parameter may be a channel name and text parameter includes*

Art Unit: 3992

payload text to be sent to channel; §3.2.2 – messages sent to a channel are sent to each client on the channel).

IRC RFC does not specifically teach the claimed aggregation step. However, Friedman teaches the claimed aggregation step including:

aggregating, by said server in a time interval determined in accordance with a predefined criterion, said payload portions of said messages to create an aggregated payload (*Friedman, Page 5 – Dysfc - messages are buffered and every 1 millisecond they are packed and sent as one packed message*);

forming an aggregated message using said aggregated payload; (*Friedman, Page 5 – Dysfc – packed message is sent*).

At the time the invention was made, it would have been obvious to one of ordinary skill in the art to utilize Friedman's method of aggregating messages because it offers the advantage of drastically increasing the throughput of messages by reducing contention on the network and decreasing the load on receiving processors thus lowering latency (*Friedman, pages 5-6*).

With regards to claim 2, IRC RFC as modified teaches said time interval is a fixed period of time (*Friedman, Page 5 – Dysfc - messages are buffered and every 1 millisecond they are packed and sent as one packed message*).

With regards to claim 3, IRC RFC as modified teaches said time interval corresponds to a time for said server to receive at least one message from each host computer belonging to

Art Unit: 3992

said first message group (*Friedman, Page 5 – Dysfc - messages are buffered and every 1 millisecond they are packed and sent as one packed message*).

With regards to claim 4, IRC RFC as modified teaches creating, by one of said plurality of host computers, said first message group by sending a first control message to said server via said unicast network (*IRC RFC, § 1.3 - "To create a new channel or become part of an existing channel, a user is required to JOIN the channel. If the channel doesn't exist prior to joining, the channel is created and the creating user becomes a channel operator."; §4.2.1 – join command is sent by a user in order to join/create a channel*).

With regards to claim 5, IRC RFC as modified teaches the step of joining, by some of said plurality of host computers, said first message group by sending control messages via said unicast network to said server specifying said first message group (*IRC RFC, § 1.3 - "To create a new channel or become part of an existing channel, a user is required to JOIN the channel. If the channel doesn't exist prior to joining, the channel is created and the creating user becomes a channel operator."; §4.2.1 – join command is sent by a user in order to join/create a channel*).

With regards to claim 6, IRC RFC as modified teaches network is Internet and said server communicates with said plurality of host computers using a session layer protocol (*IRC RFC, §1 – IRC protocol utilizes TCP/IP network*).

CORRESPONDENCE

All correspondence relating to this ex parte reexamination proceeding should be directed:

By EFS: Registered users may submit via the electronic filing system EFS-Web, at <https://sportal.uspto.gov/authenticate/authenticateuserlocalepf.html>.

By Mail to: Mail Stop *Ex Parte* Reexam
Central Reexamination Unit
Commissioner for Patents
United States Patent & Trademark Office
P.O. Box 1450
Alexandria, VA 22313-1450

By FAX to: (571) 273-9900
Central Reexamination Unit

By hand: Customer Service Window
Randolph Building
401 Dulany Street
Alexandria, VA 22314

For EFS-Web transmissions, 37 CFR 1.8(a)(1)(i) (C) and (ii) states that correspondence (except for a request for reexamination and a corrected or replacement request for reexamination) will be considered timely filed if (a) it is transmitted via the Office's electronic filing system in accordance with 37 CFR 1.6(a)(4), and (b) includes a certificate of transmission for each piece of correspondence stating the date of transmission, which is prior to the expiration of the set period of time in the Office action.

Application/Control Number: 90/011,033

Page 10

Art Unit: 3992

Any inquiry concerning this communication or earlier communications from the Examiner, or as to the status of this proceeding, should be directed to the Central Reexamination Unit at telephone number (571) 272-7705.

Signed:

/Andrew Nalven/

Andrew Nalven
CRU Examiner
GAU 3992
(571) 272-3839

Conferee: ESK

Conferee: WNT

IN THE UNITED STATES PATENT AND TRADEMARK OFFICE

In re Reexamination of)	MAIL STOP Ex Parte Reexam
U.S. Patent No. 5,822,523)	Group Art Unit: 3992
Jeffrey J. Rothschild et al.)	Examiner: Andrew Nalven
Issued: October 13, 1998)	Confirmation No.: 1686
Reexamination Control No.: 90/011,033)	
For: SERVER-GROUP MESSAGING)	
SYSTEM FOR INTERACTIVE)	
APPLICATIONS)	

PETITION FOR EXTENSION OF TIME UNDER 37 C.F.R. §1.550(c)

Commissioner for Patents
P.O. Box 1450
Alexandria, VA 22313-1450

Sir:

Patent Owner hereby petitions pursuant to the provisions of 37 C.F.R. §1.550(c) for a one month extension of time to respond to the Official Action dated December 3, 2010. If granted, the extended due date will be March 3, 2011.

The undersigned attempted to contact Examiner Nalven to arrange for an interview prior to the response due date. It is understood that Examiner Nalven will not be back in the Office until February 7, 2011, which is after the February 3, 2011 due date for a reply. Accordingly, Patent Owner respectfully requests an extension of time.

The purpose of the interview to present several detailed arguments related to the outstanding Office Action and to explore any concerns or evidentiary issues that the Office may raise. Additionally, the Patent Owner is attempting to arrange for an expert to attend the interview. Of course, the goal of the interview is to facilitate an understanding of those arguments by the Office and gain an understanding the

Buchanan Ingersoll & Rooney PC
Attorneys & Government Relations Professionals

Office's initial impression so as to facilitate the Patent Owner providing a complete and appropriate response to the outstanding Office Action.

Accordingly, Applicants respectfully request an Extension of Time until **March 3, 2011**.

When Examiner Nalven returns from his leave, the undersigned will attempt to arrange for an interview the third week of February.

The Director is hereby authorized to charge the fee under 37 C.F.R. §1.17(g) and any other appropriate fees under 37 C.F.R. §§ 1.16, 1.17 and 1.20(d) and 1.21 that may be required by this paper, and to credit any overpayment, to Deposit Account No. 02-4800.

Respectfully submitted,

BUCHANAN INGERSOLL & ROONEY PC

Date: January 21, 2011

By:

Charles F. Wieland III
Registration No. 33096

Customer No. 21839
703 836 6620

CERTIFICATE OF SERVICE

It is hereby certified by the undersigned that a true copy of the foregoing Petition for Extension of Time Under 37 C.F.R. §1.550(c) was sent via first class mail to:

NOVAK DRUCE + QUIGG, LLP
1000 Louisiana Street
53rd Floor
Houston, Texas 77002

on this 21st day of January 2011.



Charles F. Wieland III
Registration No. 33096

Electronic Patent Application Fee Transmittal

Application Number:	90011033
Filing Date:	14-Jun-2010
Title of Invention:	SERVER-GROUP MESSAGING SYSTEM FOR INTERACTIVE APPLICATIONS
First Named Inventor/Applicant Name:	5,822,523
Filer:	Charles F. Wieland III/Geri Spicknall
Attorney Docket Number:	18830.0003

Filed as Large Entity

ex parte reexam Filing Fees

Description	Fee Code	Quantity	Amount	Sub-Total in USD(\$)
Basic Filing:				
Pages:				
Claims:				
Miscellaneous-Filing:				
Petition:				
Patent-Appeals-and-Interference:				
Post-Allowance-and-Post-Issuance:				
Extension-of-Time:				
Petition fee- 37 CFR 1.17(g) (Group II)	1463	1	200	200

Description	Fee Code	Quantity	Amount	Sub-Total in USD(\$)
Miscellaneous:				
Total in USD (\$)				200

Electronic Acknowledgement Receipt

EFS ID:	9284252
Application Number:	90011033
International Application Number:	
Confirmation Number:	1686
Title of Invention:	SERVER-GROUP MESSAGING SYSTEM FOR INTERACTIVE APPLICATIONS
First Named Inventor/Applicant Name:	5,822,523
Customer Number:	21839
Filer:	Charles F. Wieland III/Geri Spicknall
Filer Authorized By:	Charles F. Wieland III
Attorney Docket Number:	18830.0003
Receipt Date:	21-JAN-2011
Filing Date:	14-JUN-2010
Time Stamp:	17:56:57
Application Type:	Reexam (Patent Owner)

Payment information:

Submitted with Payment	yes
Payment Type	Deposit Account
Payment was successfully received in RAM	\$ 200
RAM confirmation Number	4883
Deposit Account	024800
Authorized User	

The Director of the USPTO is hereby authorized to charge indicated fees and credit any overpayment as follows:

Charge any Additional Fees required under 37 C.F.R. Section 1.17 (Patent application and reexamination processing fees)

File Listing:					
Document Number	Document Description	File Name	File Size(Bytes)/ Message Digest	Multi Part /.zip	Pages (if appl.)
1	Reexam Request for Extension of Time	001EOT.pdf	87066	no	3
			57aad3988710104fa8d60087c6337f4f1d49fcb8		
Warnings:					
Information:					
2	Fee Worksheet (PTO-875)	fee-info.pdf	30218	no	2
			32bd11fb8ec7d9a9b737471c1d57699ee96a09c9		
Warnings:					
Information:					
Total Files Size (in bytes):			117284		
<p>This Acknowledgement Receipt evidences receipt on the noted date by the USPTO of the indicated documents, characterized by the applicant, and including page counts, where applicable. It serves as evidence of receipt similar to a Post Card, as described in MPEP 503.</p> <p><u>New Applications Under 35 U.S.C. 111</u> If a new application is being filed and the application includes the necessary components for a filing date (see 37 CFR 1.53(b)-(d) and MPEP 506), a Filing Receipt (37 CFR 1.54) will be issued in due course and the date shown on this Acknowledgement Receipt will establish the filing date of the application.</p> <p><u>National Stage of an International Application under 35 U.S.C. 371</u> If a timely submission to enter the national stage of an international application is compliant with the conditions of 35 U.S.C. 371 and other applicable requirements a Form PCT/DO/EO/903 indicating acceptance of the application as a national stage submission under 35 U.S.C. 371 will be issued in addition to the Filing Receipt, in due course.</p> <p><u>New International Application Filed with the USPTO as a Receiving Office</u> If a new international application is being filed and the international application includes the necessary components for an international filing date (see PCT Article 11 and MPEP 1810), a Notification of the International Application Number and of the International Filing Date (Form PCT/RO/105) will be issued in due course, subject to prescriptions concerning national security, and the date shown on this Acknowledgement Receipt will establish the international filing date of the application.</p>					



UNITED STATES PATENT AND TRADEMARK OFFICE

UNITED STATES DEPARTMENT OF COMMERCE
United States Patent and Trademark Office
Address: COMMISSIONER FOR PATENTS
P.O. Box 1450
Alexandria, Virginia 22313-1450
www.uspto.gov

APPLICATION NO.	FILING DATE	FIRST NAMED INVENTOR	ATTORNEY DOCKET NO.	CONFIRMATION NO.
90/011,033	06/14/2010	5,822,523	0078494-000001	1686

21839 7590 01/25/2011

BUCHANAN, INGERSOLL & ROONEY PC
POST OFFICE BOX 1404
ALEXANDRIA, VA 22313-1404

EXAMINER

ART UNIT PAPER NUMBER

DATE MAILED: 01/25/2011

Please find below and/or attached an Office communication concerning this application or proceeding.



UNITED STATES PATENT AND TRADEMARK OFFICE

Commissioner for Patents
United States Patents and Trademark Office
P.O. Box 1450
Alexandria, VA 22313-1450
www.uspto.gov

THIRD PARTY REQUESTER'S CORRESPONDENCE ADDRESS
NOVAK DRUCE & QUIGG, LLP
(NDQ REEXAMINATION GROUP)
1000 LOUISIANA STREET, FIFTY-THIRD FLOOR
HOUSTON, TX 77002

Date:

MAILED

JAN 25 2011

CENTRAL REEXAMINATION UNIT

EX PARTE REEXAMINATION COMMUNICATION TRANSMITTAL FORM

REEXAMINATION CONTROL NO. : 90011033
PATENT NO. : 5822523
ART UNIT : 3992

Enclosed is a copy of the latest communication from the United States Patent and Trademark Office in the above identified ex parte reexamination proceeding (37 CFR 1.550(f)).

Where this copy is supplied after the reply by requester, 37 CFR 1.535, or the time for filing a reply has passed, no submission on behalf of the ex parte reexamination requester will be acknowledged or considered (37 CFR 1.550(g)).

**Decision on Petition for Extension
of Time in Reexamination**

Control No.:90/011,033

1. THIS IS A DECISION ON THE PETITION FILED 21 January 2011.
2. THIS DECISION IS ISSUED PURSUANT TO:
 - A. 37 CFR 1.550(c) – The time for taking any action by a patent owner in an *ex parte* reexamination proceeding will be extended only for sufficient cause and for a reasonable time specified.
 - B. 37 CFR 1.956 – The time for taking any action by a patent owner in an *inter partes* reexamination proceeding will be extended only for sufficient cause and for a reasonable time specified.The petition is before the Central Reexamination Unit for consideration.
3. FORMAL MATTERS
Patent owner requests that the period for responding to the Office action mailed on action mailed 04 November 2010, which set a period of two (2) months for filing a response thereto, be extended by one (1) month.
 - A. Petition fee per 37 CFR §1.17(g):
 - i. Petition includes authorization to debit a deposit account.
 - ii. Petition includes authorization to charge a credit card account.
 - iii. Other: _____.
 - B. Proper certificate of service was provided. (Not required in reexamination where patent owner is requester.)
 - C. Petition was timely filed.
 - D. Petition properly signed.
4. DECISION (See MPEP 2265 and 2665)
 - A. Granted or Granted-in-part for _____, because petitioner provided a factual accounting that established sufficient cause. (See 37 CFR 1.550(c) and 37 CFR 1.956).
 Other/comment: _____.
 - B. Dismissed because:
 - i. Formal matters (See unchecked box(es) (A, B, C and/or D) in section 4 above).
 - ii. Petitioner failed to provide a factual accounting of reasonably diligent behavior by all those responsible for preparing a response to the outstanding Office action within the statutory time period.
 - iii. Petitioner failed to explain why, in spite of the action taken thus far, the requested additional time is needed.
 - iv. The statements provided fail to establish sufficient cause to warrant extension of the time for taking action.
 - v. The petition is moot.
 - vi. Other/comment: The petitioner has not set forth explicit reasons why the expert is needed and a factual accounting to date why one could not be timely retained.
5. CONCLUSION

Telephone inquiries with regard to this decision should be directed to Mark Reinhart at 571-272-1611. In his/her absence, calls may be directed to Eric Keasel at 571-272-4929 in the Central Reexamination Unit.

/Mark Reinhart/
[Signature]

SPE Art Unit 3992
(Title)

IN THE UNITED STATES PATENT AND TRADEMARK OFFICE

In re Reexamination of)	MAIL STOP REEXAMINATION
)	
U.S. Patent No. 5,822,523)	Group Art Unit: 3992
)	
Jeffrey J. Rothschild et al.)	Examiner: Andrew Nalven
)	
Issued: October 13, 1998)	Confirmation No.: 1686
)	
Reexamination Control No.: 90/011,033)	
)	
Filing Date: June 14, 2010)	
)	
For: SERVER-GROUP MESSAGING)	
SYSTEM FOR INTERACTIVE)	
APPLICATIONS)	

AMENDMENT

Commissioner for Patents
P.O. Box 1450
Alexandria, VA 22313-1450

Sir:

In response to the Office Action dated December 3, 2010, please amend the
above-identified patent as follows:

TABLE OF CONTENTS

1. Claim Status11

2. Request for Interview.....11

3. Support for Newly Added Claims11

4. Background of the '523 Patent.....13

5. Claim Construction17

6. Response To Obviousness Rejection18

A. IRC RFC19

**B. Proposed Combination with Friedman Does Not Result in the Invention
.....20**

i. The Office Has Not Met Its Burden.....20

ii. An Expert in the Art Agrees22

C. No Motivation to Combine.....25

**i. The Office has Not Established a Prima Facie Case for the
Combination.....25**

ii. Again, an Expert Agrees26

D. The Features of Claim 3 Cannot be Met.....27

**i. The Time Interval Specified Within Claim 3 is Not Taught by Friedman
.....27**

7. Allowability Of Newly Added Claims28

CONCLUSIONS28

AMENDMENTS TO THE CLAIMS:

Please add new claims 7-49. Pending claims 1-6 are not changed by this paper and have not been represented below in accordance with 37 CFR 1.530(d) through (j) and MPEP § 2250. All changes are shown relative to the set of claims that appear in the issued patent.

LISTING OF CLAIMS:

7. (New) The method of claim 1, wherein said time interval is less than or equal to 200 ms.

8. (New) The method of claim 1, wherein said time interval is less than or equal to 100 ms.

9. (New) The method of claim 1, wherein said time interval is between 33 ms and 200 ms.

10. (New) The method of claim 1, wherein said aggregating is performed 5 to 30 times a second.

11. (New) The method of claim 1, wherein said server implements a group messaging protocol layered on top of a transport protocol of said unicast network, wherein said group messaging protocol uses an address space that is separate from an address space of said transport protocol.

12. (New) The method of claim 11, wherein said group messaging protocol is performed at a session layer.

13. (New) The method of claim 1, further comprising the step of performing, by said server, echo suppression.

14. (New) The method of claim 1, wherein said plurality of host computers belonging to said first message group correspond to players that are in close proximity to one another within a three-dimensional space of a computer game.

15. (New) The method of claim 1, further comprising the step of changing membership of said first message group based on activities of players within a computer game.

16. (New) The method of claim 1, further comprising the step of changing membership of said first message group based on changes in player position within a three-dimensional space of a computer game.

17. (New) The method of claim 1, wherein membership of said first message group changes dynamically over time.

18. (New) The method of claim 1, wherein membership of said first message group changes over time based on control messages received from ones of said plurality of host computers.

19. (New) The method of claim 1, wherein membership of said first message group changes over time based on indications received from ones of said plurality of host computers to join or leave said first message group.

20. (New) The method of claim 1, wherein said messages comprise application specific state information.

21. (New) The method of claim 1, wherein said unicast network is a wide area network.

22. (New) The method of claim 21, wherein said group messaging server facilitates host computer-to-host computer communication.

23. (New) The method of claim 21, wherein said group messaging server facilitates host computer-to-host computer communication usable by said plurality of host computers to maintain a consistent operating state.

24. (New) The method of claim 21, wherein said group messaging server facilitates transmission of messages between ones of said plurality of host computers, wherein said transmitted messages are usable by said plurality of host computers to maintain a consistent operating state of an application.

25. (New) The method of claim 24, wherein said application is a game.

26. (New) The method of claim 21, wherein each message of said messages comprises information that other host computers in said first message group use to maintain a consistent application state.

27. (New) The method of claim 21, wherein said messages are generated for transmission to host computers in said first message group.

28. (New) The method of claim 21, wherein said messages are sent between said plurality of host computers in said first message group via said group messaging server.

29. (New) The method of claim 1, wherein said aggregated message corresponds to a networked computer game, and wherein said first message group is only for players on a specified team within said game.

30. (New) The method of claim 1, wherein said aggregated message corresponds to a networked computer game, and wherein said aggregated message is only for players on a specified team that are within a certain area of said game.

31. (New) The method of claim 1, wherein said server is configured to receive a further message specifying said first message group and a second message group, and wherein said server is configured to transmit said further message to those of said plurality of host computers belonging to both said first and second message groups.

32. (New) The method of claim 1, wherein said server is configured to receive a further message specifying a set of message groups and operations to be performed on said specified set of message groups to determine host computers to which said further message is to be delivered.

33. (New) The method of claim 1, wherein said sending and said transmitting is implemented using a protocol that encapsulates message information within a datagram of a transport protocol of said unicast network.

34. (New) The method of claim 1, wherein said sending and said transmitting are performed by an upper-level protocol implemented above a transport layer protocol of said unicast network, wherein said transport layer protocol is TCP/IP.

35. (New) The method of claim 1, wherein said sending and said transmitting are performed by an upper-level protocol implemented above a transport layer protocol of said unicast network, wherein said plurality of host computers are unable to send upper-level protocol messages to one another except through said group messaging server.

36. (New) The method of claim 1, further comprising the steps of:
said server receiving, from one of said plurality of host computers, a control message to create said first message group; and
creating said first message group in response to receiving said control message.

37. (New) The method of claim 1, further comprising the steps of:
said server receiving, from a first host computer of said plurality of host computers, a control message to join said first message group; and
adding said first host computer to said first message group in response to receiving said request.

38. (New) The method of claim 1, further comprising the steps of:
said server receiving, from a first host computer of said plurality of host
computers, a control message to leave said first message group; and
removing said first host computer from said first message group in response
to receiving said request.

39. (New) The method of claim 1, further comprising the steps of:
said server receiving a control message to close said first message group;
and
removing said first message group in response to receiving said request.

40. (New) The method of claim 1, further comprising the steps of:
said server receiving, from a first host computer of said plurality of host
computers, a control message to query message groups of said server; and
providing said list of message groups to said first host computer in response
to said receiving said control message.

41. (New) The method of claim 1, further comprising the steps of:
said server receiving, from a first host computer of said plurality of host
computers, a control message to query members of said first message group; and
providing a list of members of said first message group to said first host
computer in response to receiving said control message.

42. (New) The method of claim 1, further comprising the steps of:
said server receiving, from a first host computer of said plurality of host
computers, a control message to query attributes of said first message group; and
providing attributes of said first message group to said first host computer in
response to receiving control message.

43. (New) The method of claim 1, further comprising the steps of:
said server receiving, from a first host computer of said plurality of host
computers, a control message to connect to said group messaging server; and
storing information regarding said first host computer in response to receiving
said control message.

44. (New) The method of claim 1, further comprising the steps of:
said server receiving, from a first host computer of said plurality of host
computers, a control message to disconnect from said group messaging server; and
removing information regarding said first host computer in response to
receiving said control message.

45. (New) The method of claim 1, wherein said forming said aggregated
message comprises compressing said aggregated payload.

46. (New) The method of claim 1, wherein said time period is dynamically
varied according to the predefined criterion.

47. (New) The method of claim 46, wherein said predefined criterion is
based on message rates received by said server.

48. (New) The method of claim 46, wherein said predefined criterion is
based on data rates received by said server.

49. (New) The method of claim 1, further comprising the step of:
processing said payload portions according to an application specific
processing function to replace data elements in said payload portions with processed
results.

REMARKS

In view of the foregoing amendments and the following remarks, the Patent Owner (PalTalk Holdings, Inc.) respectfully requests reconsideration and withdrawal of the rejections found in the Office Action of November 14, 2009.

1. Claim Status

Original claims 1-6 are under reexamination and rejected. None of the original claims have been amended. New dependent claims 7-49 have been added by the above. Claims 1-49 are currently pending before the Office for examination.

2. Request for Interview

The Patent Owner respectfully requests an interview be scheduled as soon as possible. The Patent Owner had asked for an extension of time to conduct an interview after attempting to contact the Examiner three weeks in advance of the due date to learn that he would be out of the office until after the present due date had passed. The petition for an extension of time was, however, denied.

After an interview has been conducted, a summary of the interview will be supplied along with any supplemental information or action, such as an expert's declaration, if appropriate.

3. Support for Newly Added Claims

As previously mentioned, claims 7-49 are added by the instant Amendment. Written description support for these claims exists as shown by the illustrative cites in the following table. The abbreviated quotes or paraphrasing are given for convenience and may be incomplete. These citations should, of course, be considered in the fuller context of the specification where they appear.

Claims	Written Description Support
7	Col. 25, lines 61-63 ("This basic application loop is repeated at a rate fast enough to provide an interactive experience <i>such as 5 to 30 times per second.</i> ") (emphasis added); col. 4, lines 13-21.
8	Col. 25, lines 61-63; col. 1, line 58-col. 2, line 34; col. 4, lines 13-21.
9	Col. 25, lines 61-63.
10	Col. 25, lines 61-63.
11	Col. 8, lines 34-41.
12	Col. 8, lines 34-39.
13	Col. 9, lines 40-43.
14	Col. 10, lines 1-14.
15	Col. 10, lines 13-17.
16	Col. 10, lines 13-17.
17	Col. 9, line 59-col. 10, line 19; original claims 13 and 14; col. 16, lines 64-66; col. 18, lines 27-50; col. 18, line 51-col. 19, line 9.
18	Original claims 13 and 14; col. 16, lines 64-66; col. 18, lines 27-50; col. 18, line 51-col. 19, line 9.
19	Col. 9, line 59-col. 10, line 19; original claims 13 and 14; col. 16, lines 64-66; col. 18, lines 27-50; col. 18, line 51-col. 19, line 9.
20	Col. 10, lines 52-53.
21	Col. 8, lines 22-32; col. 1, lines 57-67; col. 16, lines 20-35.
22	Col. 8, lines 22-32; col. 1, lines 57-67; col. 16, lines 20-35.
23	Col. 8, lines 22-32; col. 1, lines 57-67; col. 16, lines 20-35.
24	Col. 8, lines 22-32; col. 1, lines 57-67; col. 16, lines 20-35.
25	Col. 8, lines 22-32; col. 1, lines 57-67; col. 16, lines 20-35.
26	Col. 8, lines 22-32; col. 1, lines 57-67; col. 16, lines 20-35.
27	Col. 8, lines 22-32; col. 1, lines 57-67; col. 16, lines 20-35.
28	Col. 8, lines 22-32; col. 1, lines 57-67; col. 16, lines 20-35.
29	Col. 11, lines 9-25.
30	Col. 11, lines 9-25.
31	Col. 10, line 66 to col. 11, line 25.
32	Col. 10, line 66 to col. 11, line 25.
33	Col. 13, lines 54-62.
34	Col. 12, lines 38-48; col. 26, lines 28-29.
35	Col. 12, lines 38-48; col. 15, lines 28-37.
36	Col. 15, lines 40-43.
37	Col. 16, lines 64-66; col. 18, lines 27-50.
38	Col. 16, lines 64-66; col. 18, line 51-col. 19, line 9.
39	Col. 16, lines 64-66.
40	Col. 16, lines 64-66; col. 19, lines 10-29.
41	Col. 16, lines 64-66; col. 19, lines 30-47.
42	Col. 16, lines 64-66; col. 19, lines 49-63.
43	Col. 16, lines 64-66; col. 18, lines 14-31.
44	Col. 16, lines 64-66; col. 18, lines 32-47.
45	Col. 24, lines 33-34.

46	Col. 25, lines 15-18.
47	Col. 25, lines 15-18.
48	Col. 25, lines 15-18.
49	Col. 27, lines 22-34.

4. Background of the '523 Patent

In 2002, PalTalk purchased U.S. Patent Nos. 5,822,523 and 6,226,686 (the "PalTalk Patents")¹ from HearMe, previously known as Mpath.² HearMe/Mpath, founded in 1995, developed and sold technology to permit multiple parties to play video games with each other over the Internet.

When HearMe/Mpath entered the market, the main obstacles to multiplayer online games were the limited processing power and bandwidth available to transmit messages to each player. The PalTalk Patents disclose pioneering technology directed at overcoming these obstacles. The inventions at the heart of these patents reduce the bandwidth and processing power necessary to exchange messages between various users on a network, so that during an online game, all players can have a near real-time game experience even though players may be at great distances from each other. The patents thus overcome the problem of limited bandwidth in the transmission of messages between players about the state of the game.

The PalTalk Patents are both titled "Server-Group Messaging System for Interactive Applications." As the title suggests, the focus of the patents is on interactive applications operating over a network. While the solutions described in the PalTalk Patents apply equally to any interactive application, the application typically used as an example in the Patents is a networked computer game with multiple players. See, e.g., '523 Patent, 1:14-23; 1:58 – 2:33; 2:47 – 3:22; 8:22-26; 10:1-19; 11:10-26.3.

The following example from the PalTalk Patents illustrates the basic

¹ U.S. Patent Nos. 5,822,523 and 6,226,686 Patent are related and both under reexamination. The application that led to issuance of the '686 Patent is a continuation of U.S. Application No. 08/896,797, which is a continuation of the application that led to issuance of the '523 Patent. The control number for the '686 patent is 90/011,036. An Office Action has not issued in the co pending reexamination proceeding

² PalTalk also purchased a range of other intellectual property and physical assets from HearMe/Mpath.

functionality in an exemplary embodiment. A multi-player computer video game has characters playing against each other in a three-dimensional game environment. The actual players might be located in different areas of the country connected by the Internet, each user with the game environment reproduced on his or her computer screen. To maintain consistency, the game "state," or status, should be consistent between all of the users' computers. The computers achieve this consistency by continuously exchanging messages. *Id.* at 1:66-2:4. These messages can contain "a wide variety of information specific to the game" necessary to maintain consistency between players such as position and velocity information for the players and other information about player actions that may affect the players in the game. *Id.* at 2:8-12.

The number of messages that should be sent between computers to keep an application current on the players' computers increases with the number of players. Although advances in technology have increased network bandwidth, the complexity of games has increased as well, thereby increasing the amount of data that should be transmitted to other players to maintain a consistent game state. Thus, the bandwidth limitations addressed by the PalTalk Patents are just as relevant today as when the original application for the '523 Patent was filed nearly 15 years ago.

The inventions described in the PalTalk Patents solve problems of interactive network applications by introducing what is called a "group messaging server." '523 Patent, *Abstract*. The users' computers in the system are referred to as "host computers."

Figure 5 of the PalTalk Patents shows an exemplary embodiment of a network implemented pursuant to the inventions described in the PalTalk Patents. Item 62 is the group messaging server. Items 58, 59, 60, and 61 are host computers. The remaining items are traditional network components, such as routers and links. *Id.* at 8:61-9:1.

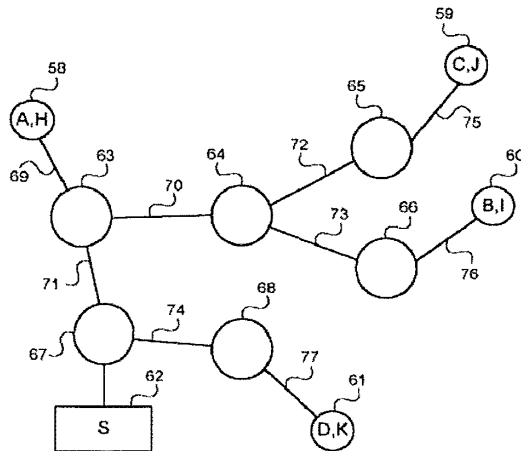

FIGURE 5

In a traditional network, if host computer 58 wanted to update host computers 59, 60, and 61 with information about an interactive application that they were sharing, host computer 58 would have to send three separate messages — one to host 59, one to host 60, and one to host 61

Using the inventions described in the PalTalk Patents, host computer 58 could achieve the same result by sending a single message to the group messaging server 62. The group messaging server would receive the message from host computer 58 and generate a message to each of hosts 59, 60, and 61. *Id.* at 9:1-4. In effect, the number of outgoing messages sent by any individual host computer can be equal to one (1) using the PalTalk invention, whereas the number of messages was previously equal to the number of players (minus one for the sender). This is far different from the applied documents (Friedman and IRC RFC), discussed below, even if taken together in the manner suggested by the Office Action.

The number of outgoing messages from the sender is reduced in the above example. Using only this feature of the PalTalk Patents, the number of messages received by a host computer would remain the same. The PalTalk Patents provide a further solution to the desire to reduce the number of messages on the network by aggregating messages at the group messaging server. *Id.* at 10:20-22. Instead of separately sending received messages to each

of the hosts, the group messaging server can instead collect multiple messages from different hosts and forward them to the destination host computer as a single message.

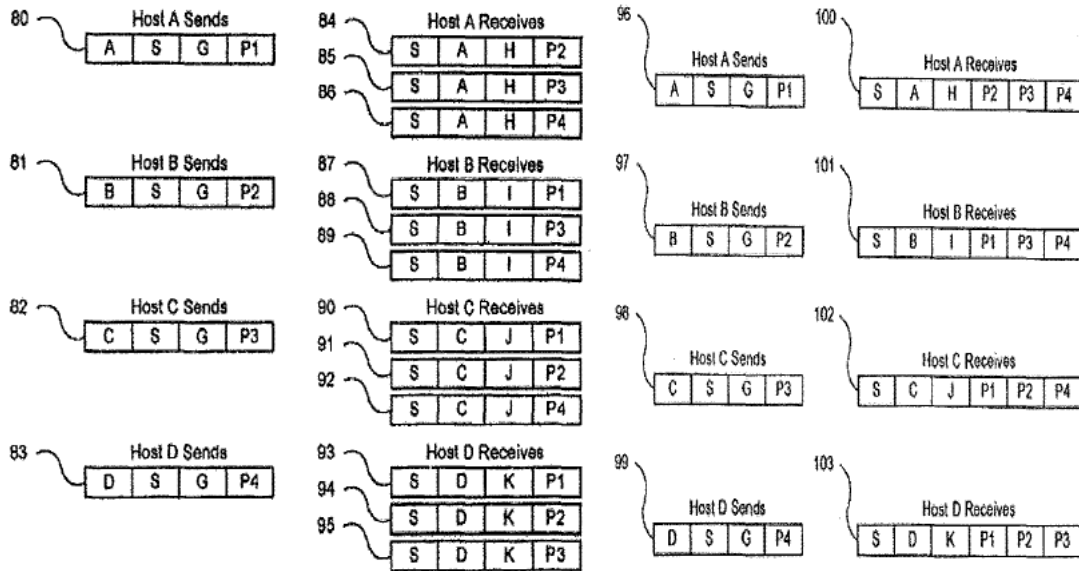

FIGURE 6

FIGURE 7

Figures 6 and 7 shown above provide an example of the messages sent by the group messaging server without and with aggregation, respectively. *Id.* at 9:23-26. Without aggregation (on the left), each of the four host computers sends a single message with data being sent between hosts. *See, e.g., id.* at 9:10-13. The group messaging server separately sends each recipient host computer a copy of the messages that it received, for a total of three received messages (host A receives three separate messages with payloads P2, P3, and P4). *Id.* at 9:27-40. With aggregation, although the group messaging server receives the same number of messages from the hosts, each recipient host computer receives only a single message in this example. The payload of the single message, however, includes an aggregated payload consisting of the relevant data received by the group messaging server (*e.g.*, host A receives a combined payload containing P2, P3, and P4). *Id.* at 10:20-43.

In summary, the PalTalk Patents describe a system for reducing both the network load and the message processing requirements that arise because of network communications in a multi-user interactive application. The system reduces the network load by using a group messaging server as a destination for messages between host computers. The group messaging server may be responsible for tracking groups and group membership, as specified in claims 4 and 5 of the '523 Patent. The group messaging server may further reduce the load on the network by aggregating the messages that it receives for a particular host computer. Aggregation allows more efficient data communication by reducing the number of messages that a recipient host is expected to process. In one of its key applications, online gaming, the group messaging server allows for more efficient communication of large amounts of information between players, thus enabling games to become quicker, be more realistic and, consequently, more attractive to consumers.

5. Claim Construction

To facilitate a discussion and understanding, the Patent Owner offers the comments regarding the meaning of various claim terms. In light of the above description, which fully supports these interpretations, and from the context of the claims themselves, it is respectfully submitted that "aggregating by said server in a time interval determined in accordance with a predefined criterion, said payload portions of said messages to create an aggregated payload" means that a group messaging server forms one or more aggregated payloads by aggregating at least one data item from the payloads of all the claimed messages it receives from the claimed plurality of host computers within a certain time period. The data items may be aggregated in any order, and not require "total ordering" as disclosed in Friedman, discussed below, and the time period is certain in that it arises from criteria specified prior to the beginning of the time interval.

Hence, consistent with the above, the phrase "aggregating said payload portions" means aggregating at least one data item from the payloads of the claimed messages from the claimed plurality of host computers. Likewise, "aggregated

payload" means one or more collections of at least one data item from the payloads of the claimed messages from the claimed plurality of host computers, where each data item retains its identity and may be extracted from the collection. Further, "forming an aggregated message using said aggregated payload" would thus mean employing one or more aggregated payloads in forming one or more aggregated messages. The basic theme is that "aggregating/aggregated" means to collect two or more data items together as a unit from the claimed plurality of host computers; however, each data item can retain its identity and may be extracted from the unit.

What should be apparent from a review of the claims, whether read alone or broadly interpreted in a manner consistent with the written description, is that the group messaging server forms one or more aggregated payloads by aggregating at least one data item from the payloads of all the claimed messages it receives from the claimed plurality of host computers within a certain time period.

6. Response To Obviousness Rejection

Claims 1-6 stand rejected under 35 U.S.C. §103(a) as being obvious over J. Oikarinen and D. Reed, "Request for Comment (RFC) 1459 - Internet Relay Chat Protocol," with a putative publication date of May 1993, 65 pages, ("IRC RFC") in view of R. Friedman and R. Van Renesse, "Packing Messages as a Tool for Boosting the Performance of Total Ordering Protocols," with a putative publication date of July 7, 1995 ("Friedman"). This rejection is respectfully traversed.

It must be initially noted that the Requester³ cannot establish a publication date for the Friedman document by the simple assertion of it having a date on its face of July 7, 1995. What the Requester did not tell the Patent Office is that Friedman's publication date is at best an open question.

The undersigned found only the following citation related to the publication of this document: "The 6th International Symposium on High Performance Distributed Computing (HPDC '97), August 5-8, 1997, Portland, OR, USA, Proceedings. IEEE

³ It is noted that the Requester has the burden of establishing dates of publication. The burden is on the proponent of a publication bar to show that prior to the critical date the reference was sufficiently accessible, at least to the interested public. In re Hall, 781 F.2d 897 (Fed. Cir. 1986).

Computer Society, online publication, (<http://computer.org/proceedings/hpdc/8117/8117toc.htm>), which would mean it is not prior art. A link provides the document as it appears in the record, but the authoring date of 1995 on the paper should not be confused with its possible publication date, which may well be after the filing date (February 1, 1996⁴) of the application that resulted in the '523 Patent. Cornell University lists July 1995 as the "issue" date, and April 23, 1997 as the date it was made "available", the later date having the consequence of it is not being prior art.⁵ An explanation of these metadata fields suggests that the "issue" date can be a non-publication event, such as sending a document to a printer.⁶ The appearance of the "available" date means that the "issue" date is "insufficiently precise" according to its definition.

A. IRC RFC

The IRC RFC represents a request for comments about a proposed experimental Internet Relay Chat (IRC) protocol. The Abstract at page 1, states that the IRC protocol "was developed ... as a means for users on a BBS [Bulletin Board Service] to chat amongst themselves. ... The IRC protocol is a text-based protocol, with the simplest client being any socket program capable of connecting to the server." Figure 1 illustrates that each sever acts as a central node for the rest of the net it "sees".

⁴ Friedman does not qualify as prior art under 35 U.S.C. §102(b). Patent Owner has not determined whether it appropriate to "swear behind" the Friedman document, but reserves the right to do so.

http://ecommons.library.cornell.edu/handle/1813/7184?mode=full&submit_simple>Show+full+item+record

⁶ See the example at the end of the metadata definitions ("When DC.Date and DC.Date->Issued are insufficiently precise, use this subelement to indicate when the resource content may be considered to hold true. In a somewhat labored example, suppose a public transit system is in the practice of creating a new bus schedule, allowing two weeks for issuance of a print run, allowing two more weeks for printed copies of the schedule to be placed in distribution racks, and finally being required to do so at least one month in advance of drivers switching the timing on their routes. Metadata for such a bus schedule might include all of the following elements:

DC.Description: City Bus Schedule
DC.Date->Created: 1997-11-01
DC.Date->Issued: 1997-11-15

IRC RFC identifies several problems with IRC including scalability, which is important to multi-player games with large data exchange. For example, IRC RFC explains that:

It is widely recognized that this protocol does not scale sufficiently well when used in a large arena. The main problem comes from the requirement that all servers know about all other servers and users and that information regarding them be updated as soon as it changes. It is also desirable to keep the number of servers low so that the path length between any two points is kept minimal and the standing tree is strongly branched as possible. IRC § 9.1

Another problem with IRC is that "the current channel layout requires that all servers know about all channels, the respective inhabitation and properties." IRC RFC § 9.2.2. These problems with IRC are central to the problems addressed in the '523 Patent and provide a good example why IRC is not applicable to the concept of a group message server, as further explained below.

IRC serves to provide only a limited set of services and would not have been capable to support additional functionality, such as the aggregation of messages of the kind described in the '523 Patent, without significantly augmenting the system in a way not disclosed by it or Friedman. In fact, attempting to combine it with Friedman would violate one of the predicates of IRC RFC, *i.e.*, the predicate that the message route over servers should be as short as possible. Friedman is designed in a way to extend the route by first sending it to a "sequencer", then on to a process for which the message is intended.

B. Proposed Combination with Friedman Does Not Result in the Invention

i. The Office Has Not Met Its Burden

As positively recited in claim 1, the group messaging server "in a time interval determined in accordance with a predefined criteria [aggregates] said payload portions of said messages to create an aggregated payload." The Office

DC.Date->Available: 1997-12-01/1998-06-01

DC.Date->Valid: 1998-01-01/1998-06-01"). <http://dublincore.org/documents/date-element/>

acknowledges this is not present in IRC RFC, but suggests that Friedman provides this feature in its disclosure of messages being "buffered and every / milliseconds they are packed and sent as one packed message." The Patent Owner respectfully disagrees.

Friedman operates at a completely different level than does IRC. That is, Friedman merely offers a "buffering" function wherein "processes are not allowed to send their messages all the time. Instead, messages are buffered and every / millisecond they are packed and sent as one packed message." Page 5, first line of "Dysfc" section. This passage deals with message buffering *within a single process*. It is not aggregating messages from a plurality of hosts. This is not equivalent to and has no actual bearing on "aggregating" in the context of the '523 claims, claim 1 of which recites *inter alia* "aggregating, by said [group message] server in a time interval determined in accordance with a predefined criterion, said payload portions of said messages [sent by a plurality of host computers belonging to a first message group] to create an aggregated payload". Buffering data within a process on a host prior to transmission is a far different concept than aggregating messages transmitted from a number of hosts in a network.

This understanding is in accordance with the specification of the '523 patent. Aggregation is described throughout the '523 Patent. An example of aggregation is contained in the patent as follows (the ULP server corresponding to the group message server of the claims):

A key concept in the present invention is the aggregation of multiple messages in a message queue into a single ULP receive message to a host that contains multiple payload items in the payload. The ULP server process 140 removes payload items from a message queue 143 for a host and accumulates them in an aggregation buffer 149. The aggregation buffer has buffer areas for each host for which there is a message queue. These individual host areas within the aggregation buffer are called host aggregation buffers. The start and end of this aggregation period can be controlled in a number of ways that will be described in the next sections. At the end of the aggregation period, the each host aggregation buffer may hold multiple payload items. The host aggregation buffer will hold a message count of the payload items followed by the multiple payload items. The contents of a

host aggregation buffer along with the ULP host address of the corresponding host are sent to the GMS control function 136 where it will be used to create a ULP receive message sent to the destination host. The GMS control function 136 will use the destination ULP host address to look up the TLP address of the host from the host address map 137. This will be used to create a TLP header for the message 123. The ULP message type 124 will be ULP receive, the destination ULP address 125 will be the destination host, the address count will be 0 and there will be no auxiliary addresses. The payload in this case will have a message count 116 set by the message count value from the host aggregation buffer. The payload will contain all of the payload items from the host aggregation buffer.

The '523 Patent is clearly describing a type of aggregation that takes place in a shared, interactive application aggregating messages from a plurality of hosts received over a wide area network. As such, the type of aggregation described in the '523 Patent and positively recited in the pending claims in the Claim Construction section above, is not so broad as to cover every combination of data or every possible use of the word in its plain English meaning. The term "aggregating" and "aggregated" should be construed with the related concepts of "aggregating, by said server in a time interval determined in accordance with predefined criteria, said payload portions of said messages to create an aggregated payload" and "aggregated message". Hence, it is respectfully submitted that the pending claims require a particular kind of aggregation of message data, and not simply any kind of combination of data.

ii. An Expert in the Art Agrees

As explained by Dr. Mayer-Patel in his concurrently filed Declaration, the Office's analysis is fundamentally flawed in several ways including:

- The aggregation step of claim 1 is not taught by Friedman;
- The time interval specified within claim 3 is not taught by Friedman; and
- Combining the two references would not have been obvious and, in fact, such a combination would have been regarded as harmful to performance.

As to the first point, Dr. Mayer-Patel identifies a component of claim 1 of the '523 Patent is the aggregation step in which the message server combines portions of the payloads of multiple messages from different hosts in order to create an aggregated payload that is then delivered to a recipient. That is, claim 1 recite *inter alia*, a plurality of host computers belonging to a first message group send messages to a group message server via an unicast network. The messages contain a payload portion and a portion for identifying the first message group. The group message server, in a time interval determined in accordance with a predefined criterion, aggregates the payload portions of the messages to create an aggregated payload. An aggregated message is formed using the aggregated payload. The group message server transmits via the unicast network the aggregated message to a recipient host computer belonging to said first message group.

It is important to note that the '523 Patent makes a clear distinction between the function of "host" computers and the function of a "message server". Host computers are the originators and ultimate recipients of messages while the message server forms part of the delivery infrastructure. In Friedman, the term "process" is used to describe the participants of the group communication. This could mean various processes on one computer or on a number of computers, according to Dr. Mayer-Patel.

Dr. Mayer-Patel agrees that the claim language very specifically indicates that the message server is the entity that performs the aggregation step. In contrast, the total ordering protocols described in Friedman teach that the host computers perform a buffering step prior to initial transmission of a message. That is, as Dr. Mayer-Patel sees it, a process in Friedman's system buffers messages that it is about to send, and not messages from other host computers. As Dr. Mayer-Patel states, the difference between the aggregation step taught in the patent and the buffering described in Friedman is important and clear. The message server performs the aggregation step described in the '523 Patent as part of the message delivery infrastructure, as Dr. Mayer-Patel explains. The server of the '523 Patent collects multiple messages from multiple hosts after initial transmission of those messages, producing a single aggregate message en route to the destination.

In contrast, the buffering described in Friedman is performed at the host computers prior to transmission via a message delivery infrastructure, as Dr. Mayer-Patel further explains. All of the protocols described in Friedman rely on some sort of reliable group broadcast infrastructure. The infrastructure used by Friedman is called Horus and is specifically described in Friedman, Section 2. The buffering described in some of these protocols is always done at a host computer and not within this delivery infrastructure, as articulated by Dr. Mayer-Patel.

The above analysis applies to all eight of the total ordering protocols described in Friedman. Because the office action refers specifically to the "Dysfc" protocol as teaching "aggregation", Dr. Mayer-Patel expands his analysis with respect to the details of Dysfc.

Dysfc is described as being "essentially the same as Dynseq." In Dynseq, a specific host is chosen to be the message sequencer in order to achieve a total ordering of messages. To send a message to the group, a host must first send the message to the sequencer. The sequencer then relays the message to the group. That is, it basically acts only as a relay, without any suggestion of aggregating the message. The description of Dysfc builds upon Dynseq by adding the further stipulation that, "processes are not allowed to send their messages all the time. Instead, messages are buffered and very / millisecond they are packed and sent as one packed message."

This is the part of Dysfc that the Office action is referring to as having taught "aggregation." This buffering step, however, is being performed at the hosts before any message has been transmitted for the first time, as this article is understood by one skilled in the art, Dr. Mayer-Patel. This is distinctly different from what is described in the '523 Patent wherein messages are aggregated at the message server within the delivery infrastructure itself. Claim 1 clearly describes a sending step in which the message is transmitted from the host to the message server that occurs before the aggregation step that occurs subsequently at the message server. Further, the transmission of buffered messages that does occur in Dysfc is not sent to the group, but is, in fact, sent to the sequencer (another host) via unicast.

C. No Motivation to Combine

i. The Office has Not Established a *Prima Facie* Case for the Combination

It is noted that the Office acknowledges that the aggregating step is not met by IRC RFC but in suggesting that Friedman discloses buffering as this aggregating step, it is respectfully submitted the Office is missing the fundamental distinction between the two mechanisms.

Friedman deals with total ordering of messages, *i.e.*, wherein messages from several processes are all received by everyone in the same order. This has no real bearing on an IRC system. To the degree that there is a need for a specific sequence, that would be in the context of a chat. Like any conversation, one might expect a comment will receive a reply, but the comment must be received first by a user for that user to reply. There would be no logical possibility for these conversational messages to be combined at all, either by buffering or by aggregation, since the sender has to wait for a reply.

On one hand, to the degree one might imagine that on a BBS, one comment might receive several replies at the same time on a channel, the buffering function of Friedman, identified above, would have no bearing since it occurs within a single process, and not on a network level involving a plurality of hosts.

On the other hand, to the degree one thinks the "sequencer" of Friedman that provides total ordering could be added to IRC to deal with multiple, basically simultaneous replies to a comment, this would not be logical since it does not matter in which order the replies would be displayed since they would not be responsive to each other. In fact, providing a total order sequence in this context would not only have no advantage, it would be counter-intuitive since it would increase overhead by sending the message over the same servers twice for no apparent advantage. In fact, it would seem to violate one of the basic predicates of IRC RFC in that in both Example 6 cited by the Office, section 3.1 and elsewhere, IRC RFC builds on the notion that "[t]he path of a message being delivered is the shortest path between any two points on the spanning tree [of servers to reach any client]". Section 3.1, page 10. To apply the sequencer of Friedman would require sending all messages to the

sequencer, then sending the messages to "everyone", meaning that the messages travel over servers twice, once to be placed in the total order and again to be sent to the intended recipients. Thus, the intended purpose or function of IRC RFC in reducing the travel of messages, or the purpose of total ordering by Friedman, would be destroyed by the combination suggested in the Office Action. As such, a *prima facie* case of obviousness cannot be established. *In re Gordon*, 733 F.2d 900, 221, USPQ 1125 (Fed. Cir. 1984).

The Office suggests that the buffering of messages in Friedman reduces contention and latency problems, but it is noted that even if one assumes *arguendo* this is true for when a process buffers messages for a short period before sending out one buffered message, it would not meet the recitations of the claims wherein a group message server received messages from a plurality of hosts, and therefore the hypothetical combination would not meet the claim recitations.

ii. Again, an Expert Agrees

According to by Dr. Mayer-Patel, even if one were to assume for a moment the combination of the two documents, IRC RFC and Friedman, were to teach each element of the claims (which is not true), doing so would not have been obvious for a number of reasons.

First, the application domains addressed are very different. The IRC RFC describes an application that operates across a very wide area with loosely connected components and messages generated at human timescales (*i.e.*, seconds and minutes). In contrast, the total ordering protocols described in Friedman are intended for applications that are tightly coordinated with messages generated at very fine timescales (*i.e.*, milliseconds).

Second, aggregating messages within a chat application would have worked against the application's goals and would actually degrade the performance of the system as perceived by its users, as Dr. Mayer-Patel explains. Because messages in the IRC RFC system are driven by human interaction, one expects a conversational relationship between messages of different users. In other words, after a message is sent by User A, for example, other users, say User B, responds

with a message of their own, which in reply elicits a response from User A, and so forth. Delaying messages in anticipation of aggregating them would simply work against this conversational causality. As noted in the prior analysis, much of what Friedman actually describes is buffering messages at the host prior to initial transmission. This would be particularly counter-intuitive for a chat system like IRC RFC in which a user is likely to be waiting for a response to their prior message before sending another.

In conclusion, it is Dr. Mayer-Patel's expert opinion that the message aggregation step described in claim 1 of the '523 patent is not taught by the Friedman reference because the protocols described by Friedman perform buffering at the host prior to initial transmission and do not aggregate separately transmitted messages within the message delivery infrastructure as specified in the patent. Furthermore, the time interval used to aggregate messages as described in claim 3 is not taught by any of the protocols described in Friedman. Finally, combining the two references would not have been obvious because of the difference in application domains, and the fact that message aggregation would work against the usability of a chat system.

D. The Features of Claim 3 Cannot be Met

i. The Time Interval Specified Within Claim 3 is Not Taught by Friedman

The above analysis drawing distinctions with regard to claim 1 apply to dependent claim 3 as well. Even if one were to assume *arguendo* that some combination of these documents could meet the recitations of claim 1, the specific time interval described in claim 3 ("wherein said time interval corresponds to a time for said server to receive at least one message from each host computer belonging to said first message group ") is not taught by Friedman. Claim 3 is directed to the idea of the message server waiting long enough to be able to receive at least one message from each host to be aggregated into a single message to the group.

According to Dr. Mayer-Patel, not one of the protocols described in Friedman describe an aggregation step that does this. The Office action points to the Dysfc

protocol within Friedman, referring specifically to the text "messages are buffered and every / millisecond they are packed and sent as one packed message." Note, however, that this simply describes waiting a fixed amount of time, and not waiting for the amount of time necessary to have received a message from each host. In fact, it is defined and "a very short period" that "is less than the minimal expected one-way user-to-user latency." Thus, as defined in Friedman, Friedman cannot meet the recitations of claim 3.

7. Allowability Of Newly Added Claims

Newly added claims 7-49 depend from independent claim 1, and hence are allowable over the cited art for at least the same reasons discussed above in support of those claims.

CONCLUSIONS

As shown, the IRC RFC cannot render the claims obvious because (1) the hypothetical combination is missing one or more claim elements, (2) there is no reason to combine the references, and (3) the asserted reasons for the combination would destroy the function of one or both of the purported prior art systems. Further, the date of publication date of the secondary document has not been established by the Requestor.

With virtually any patent, the individual claim elements can be found in some combination of references. But obviousness cannot be found without evidence that there was a reason for one skilled in the art to combine the references in a manner that results in the presently claimed invention. That evidence is lacking here. Indeed, it would be contrary to the evidence concerning the state of the art in 1996 to combine the documents as suggested by the Requester. Mixing and matching phrases and features of the applied documents, as the Requester has attempted to do, is improper hindsight reconstruction of the invention.

In light of the foregoing, the Patent Owner respectfully requests reconsideration and allowance of all the pending claims. Should any residual issues

exist or arise, the Examiner is invited to contact the undersigned at the number listed below.

The Director is hereby authorized to charge any appropriate fees that may be required by this paper, and to credit any overpayment, to Deposit Account No. 02-4800.

Respectfully submitted,

BUCHANAN INGERSOLL & ROONEY PC

Date: February 3, 2011

By:



Charles F. Wieland III
Registration No. 33096

Customer No. 21839
703 836 6620

CERTIFICATE OF SERVICE

It is hereby certified by the undersigned that a true copy of the foregoing
Amendment, Amendment Transmittal and accompanying Declaration of Dr. Ketan Mayer-
Patel were sent via e-mail to:

NOVAK DRUCE + QUIGG, LLP
(NDQ Reexamination Group)
1000 Louisiana Street
53rd Floor
Houston, Texas 77002

on this 3rd day of February, 2011.



Charles F. Wieland III
Registration No. 33096

IN THE UNITED STATES PATENT AND TRADEMARK OFFICE

In re Reexamination of)	MAIL STOP REEXAMINATION
U.S. Patent No. 5,822,523)	Group Art Unit: 3992
Jeffrey J. Rothschild et al.)	Examiner: Andrew Nalven
Issued: October 13, 1998)	Confirmation No.: 1686
Reexamination Control No.: 90/011,033)	
For: SERVER-GROUP MESSAGING)	
SYSTEM FOR INTERACTIVE)	
APPLICATIONS)	

DECLARATION OF KETAN MAYER-PATEL UNDER 37 CFR 1.132

Commissioner for Patents
P.O. Box 1450
Alexandria, VA 22313-1450

Sir:

I, Dr. Ketan Mayer-Patel, hereby state as follows:

I. INTRODUCTION

1. I have been retained as an independent expert witness by PalTalk Holdings, Inc., the Assignee of the Patent presently undergoing reexamination (i.e., U.S. Patent No. 5,822,523 (hereinafter "the '523 Patent")).

2. I have reviewed U.S. Patent No. 5,822,523 (Exhibit B, attached hereto), and I did not contribute to the invention described therein.

3. I am an expert in the field of networking protocols including networking protocols supporting multimedia streams including digital audio data. See Curriculum Vitae attached as Exhibit 1.

4. I received Bachelors of Arts degrees in Computer Science and Economics in 1992, a Masters of Science in 1997 from the Department of Electrical Engineering and Computer Science and a Ph.D. in 1999 from the Department of Electrical Engineering and Computer Science, all from the University of California, Berkeley.

5. I received the National Science Foundation CAREER Award in 2003 while an Assistant Professor at the University of North Carolina, Chapel Hill.

6. I have had extensive experience in both industry and academia as it relates to the technical fields relevant here. For example, I have been a programmer, a visiting researcher, and an Assistant and Associate Professor.

7. I am a co-author of numerous articles that have appeared in a number of documentd publications and proceedings.

8. Governmental agencies, such as the National Science Foundation and the Office of Naval Research, have provided funding for my research. I have also served on several NSF reviewing panels for funding recommendations.

9. I am an Associate Editor for both IEEE Transactions on Multimedia and ACM Transactions on Mutimedia Computing, Communications, and Applications, which are the two leading journals in the field.

10. I regularly serve as a member of the technical program committee for a number of different conferences and workshops including ACM Multimedia, The International Workshop on Network and Operating System Support for Digital Audio and Video (NOSSDAV), IFIP Networking, ACM Multimedia Systems (MMSys), MMEDIA, and SIGMAP.

11. I am also currently co-chair of the standing executive committee for both NOSSDAV and MMSys.

II. RETENTION AND COMPENSATION

12. I have been retained to offer an expert opinion on the prior art relevant to the '523 Patent (and other patents currently under reexamination) and the patentability of the claims undergoing reexamination.

13. My work on this case is being billed at a rate of \$480 per hour, with reimbursement for actual expenses and additional fees for travel. My compensation is not contingent upon the outcome of the case.

III. BASIS OF MY OPINION AND MATERIALS CONSIDERED

14. In preparation for this report, I have considered and relied on data or other documents identified in this report. For example, I have reviewed the Office Action dated December 3, 2010 as well as the Request for Reexamination that was filed for the '523 Patent, including several Exhibits to the Request for Reexamination. I have also reviewed the file history of the '523 Patent.

15. I have familiarized myself with the state of the art at the time the '523 Patent was filed by reviewing both patent the non-patent documents applied in the Office Action and the file histories of the '523 Patent and its related patent, U.S. Patent No.6,226,686.

16. My opinions are also based upon my education, training, research, knowledge, and experience in this technical field.

IV. SUMMARY OF MY OPINIONS

17. Based on my prior experience in the field of computer systems and networking, including network communication protocols, and based on my review of the documents relating to the pending reexamination proceeding, I have developed an understanding of the '523 Patent and the claimed invention.

18. I have been asked to compare the claims of the '523 Patent to the documents applied in the outstanding Office Action. The results of my comparison are provided below.

19. In my expert opinion, I believe that the office's analysis is fundamentally flawed in several ways including:

- The aggregation step of claim 1 is not taught by Friedman.
- The time interval specified within claim 3 is not taught by Friedman.
- Combining the two documents would not have been obvious and, in fact, such a combination would have been regarded as harmful to performance.

In each of the subsections below, I explain each of these opinions in more detail.

The aggregation step of claim 1 is not taught by Friedman.

20. Claim 1 of the '523 patent reads as follows:

1. A method for providing group messages to a plurality of host computers connected over a unicast wide area communication network, comprising the steps of:

providing a group messaging server coupled to said network, said server communicating with said plurality of host computers using said unicast network and maintaining a list of message groups, each message group containing at least one host computer;

sending, by a plurality of host computers belonging to a first message group, messages to said server via said unicast network, said messages containing a payload portion and a portion for identifying said first message group;

aggregating, by said server in a time interval determined in accordance with a predefined criterion, said payload portions of said messages to create an aggregated payload;

forming an aggregated message using said aggregated payload;
and

transmitting, by said server via said unicast network, said aggregated message to a recipient host computer belonging to said first message group.

21. A key component of this claim is the aggregation step in which the message server combines the payloads of multiple messages in order to create an aggregated payload that is then delivered to recipients. It is important to note that the patent makes a clear distinction between "host" computers and the "message server." Host computers are the originators and ultimate recipients of messages while the message server is part of the delivery infrastructure.

22. In Friedman, the term "process" is used to describe the participants of group communication. My understanding of the term "process" as used by Friedman is that these processes are located at the endpoints of a distributed system as part of the application. As endpoints, these processes originate and receive messages. As such, these processes correspond to the term "host computer" in the parlance of the patent. I arrived at this understanding because throughout the Friedman document,

there are numerous instances in which messages are specifically characterized as belonging to a particular process and the acts of sending and receiving a message are associated with the goals of the application. For example, the description of the total protocol on page 4 refers to “the application *at a process*” (emphasis added).

23. The claim language very specifically indicates that the message server is the entity that performs the aggregation step and not a host. In contrast, the total ordering protocols described in Friedman teach that the host computers perform a buffering step prior to initial transmission of a message. The difference between the aggregation step taught in the patent and the buffering described in Friedman is important and clear. The message server performs the aggregation step described in the patent as part of the message delivery infrastructure. The server collects multiple messages from multiple hosts after initial transmission of those messages, producing a single aggregate message en route to the destination.

24. In contrast, the buffering described in Friedman is performed at the host computers prior to transmission. All of the protocols described in Friedman rely on parts of a communication library called Horus described in Section 2 and Section 3.1. These facilities are part of the application (i.e., process) running on the host computers. As such, there is no separate and distinct message delivery infrastructure within the protocols described in Friedman as specified by the patent. Even if one were to distinguish the Horus library itself as a message delivery service, the buffering described in these protocols is always done prior to transmission and involves only messages from the same host and does not create an aggregate message payload from a plurality of hosts.

25. The above analysis applies to all eight of the total ordering protocols described in Friedman. Because the office action refers specifically to the “Dysfc” protocol as teaching aggregation, I will expand my analysis with respect to the details of Dysfc.

26. Dysfc is described as being “essentially the same as Dynseq.” In Dynseq, a specific host is chosen to be the message sequencer in order to achieve a total ordering of messages. To send a message to the group, a host must first send the message to the sequencer, the sequencer then relays the message to the group. The description of Dysfc builds upon Dynseq by adding the further stipulation that,

“processes are not allowed to send their messages all the time. Instead, messages are buffered and every 1 millisecond they are packed and sent as one packed message.”

27. Presumably, this is the part of Dysfc that the office action is referring to as having taught aggregation. This buffering step, however, is being performed at the hosts before any message has been transmitted for the first time. This is distinctly different from what is described in the ‘523 patent wherein messages are aggregated at the message server within the delivery infrastructure itself. Claim 1 clearly describes in the second subparagraph, a sending step in which the message is transmitted from the host to the message server that occurs before the aggregation step described in third subparagraph that occurs subsequently at the message server. Furthermore, the transmission of buffered messages that does occur in Dysfc is not sent to the group, but is, in fact, sent to the sequencer (another host) via unicast.

The time interval specified within claim 3 is not taught by Friedman

28. Claim 3 of the ‘523 patent reads,

3. The method of claim 1 wherein said time interval corresponds to a time for said server to receive at least one message from each host computer belonging to said first message group.

29. Because claim 3 is dependent on claim 1, the analysis presented above drawing a distinction between buffering at the host and aggregation within the message delivery infrastructure with regard to claim 1 applies here as well. Notwithstanding, the specific time interval described in claim 3 is also not taught by Friedman. The idea behind this claim is that the message server waits to receive at least one message from each host to be aggregated into a single message to the group. Not one of the protocols described in Friedman describe an aggregation step that does this. The office action points to the Dysfc protocol within Friedman, referring specifically to the text “messages are buffered and every 1 millisecond they are packed and sent as one packed message.” Note, however, that this simply describes waiting a fixed amount of time and not waiting for the amount of time necessary to have received a message from each host.

Combining the two documents would not have been obvious

30. Even if the combination of the two documents, IRC RFC and Friedman, were to teach each element of the claims, doing so would not have been obvious for a number of reasons.

31. First, the application domains addressed are very different. The IRC RFC describes an application that operates across a very wide area with loosely connected components and messages generated at human timescales (i.e., seconds and minutes). In contrast, the total ordering protocols described in Friedman are intended for applications that are tightly coordinated with messages generated at very fine timescales (i.e., milliseconds). Additionally, the IRC RFC specifies the use of TCP for communication while all of the Friedman protocols use UDP and rely on the availability of IP-multicast for communication between hosts.

32. Second, aggregating messages within a chat application would have worked against the application's goals and would actually degrade the performance of the system as perceived by its users. Because messages in the IRC RFC system are driven by human interaction, one expects a conversational relationship between messages of different users. In other words, after a message is sent by User A, for example, other users, say User B, responds with a message of their own, which in reply elicits a response from User A, and so forth. Delaying messages in anticipation of aggregating them would simply work against this conversational causality. As noted in the prior analysis, much of what Friedman actually describes is buffering messages at the host prior to initial transmission. This would be particularly counter-intuitive for a chat system like IRC RFC in which a user is likely to be waiting for a response to their prior message before sending another.

33. In conclusion, it is my expert opinion that the message aggregation step described in claim 1 of the '523 patent is not taught by the Friedman document because the protocols described by Friedman perform buffering at the host prior to initial transmission and do not aggregate separately transmitted messages within the message delivery infrastructure as specified in the patent. Furthermore, the time interval used to aggregate messages as described in claim 3 is not taught by any of the protocols described in Friedman. Finally, combining the two documents would

not have been obvious because of the difference in application domains and the fact that message aggregation would work against the usability of a chat system.

I hereby declare that all statements made herein of my own knowledge are true and that all statements made on information and belief are believed to be true; and further that these statements were made with the knowledge that willful false statements and the like so made are punishable by fine or imprisonment, or both, under Section 1001 of Title 18 of the United States Code and that such willful false statements may jeopardize the validity of the application or any patent issued thereon.

2/2/2011



Date

Dr. Ketan Mayer-Patel

IN THE UNITED STATES PATENT AND TRADEMARK OFFICE

In re Reexamination of U.S. Patent No. 5,822,523)
Reexamination Control No.: 90/011,033)
Filing Date: June 14, 2010)
Title: SERVER-GROUP MESSAGING SYSTEM FOR)
INTERACTIVE APPLICATIONS)
MAIL STOP *Ex Parte*
REEXAMINATION - AMENDMENT
Group Art Unit: 3992
Examiner: Andrew Nalven
Confirmation No.: 1686

AMENDMENT/REPLY TRANSMITTAL LETTER

Commissioner for Patents
P.O. Box 1450
Alexandria, VA 22313-1450

Sir:

Enclosed is a reply for the above-identified patent.

An additional claim fee is required, and is calculated as shown below:

AMENDED CLAIMS					
	No. of Claims	Highest No. of Claims Previously Paid For	Extra Claims	Rate	Additional Fee
Total Claims	49	20	29	x \$ 52 (1202)	\$ 1,508.00
Independent Claims	1	3	0	x \$ 220 (1201)	0
<input type="checkbox"/> If Amendment adds multiple dependent claims, add \$ 390 (1203)					\$ 0
Total Claim Amendment Fee					\$ 1,508.00
<input type="checkbox"/> Small Entity Status claimed - subtract 50% of Total Claim Amendment Fee					0
TOTAL ADDITIONAL CLAIM FEE DUE FOR THIS AMENDMENT					\$ 1,508.00

Charge \$1,508.00 to credit card for the fee due.

The Director is hereby authorized to charge any appropriate fees under 37 C.F.R. §§ 1.16, 1.17 and 1.20(d) and 1.21 that may be required by this paper, and to credit any overpayment, to Deposit Account No. 02-4800.

Respectfully submitted,

BUCHANAN INGERSOLL & ROONEY PC

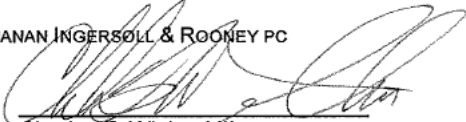
By: 
Charles F. Wieland III
Registration No. 33096

Date February 3, 2011

Customer No. 21839
703 836 6620

Buchanan Ingersoll & Rooney PC
Attorneys & Government Relations Professionals

Electronic Patent Application Fee Transmittal

Application Number:	90011033			
Filing Date:	14-Jun-2010			
Title of Invention:	SERVER-GROUP MESSAGING SYSTEM FOR INTERACTIVE APPLICATIONS			
First Named Inventor/Applicant Name:	5,822,523			
Filer:	Charles F. Wieland III/Christine Becker			
Attorney Docket Number:	0078494-000001			
Filed as Large Entity				
ex parte reexam Filing Fees				
Description	Fee Code	Quantity	Amount	Sub-Total in USD(\$)
Basic Filing:				
Pages:				
Claims:				
Reexamination claims in excess of 20	1822	29	52	1508
Miscellaneous-Filing:				
Petition:				
Patent-Appeals-and-Interference:				
Post-Allowance-and-Post-Issuance:				
Extension-of-Time:				

Description	Fee Code	Quantity	Amount	Sub-Total in USD(\$)
Miscellaneous:				
Total in USD (\$)				1508

Electronic Acknowledgement Receipt

EFS ID:	9366544
Application Number:	90011033
International Application Number:	
Confirmation Number:	1686
Title of Invention:	SERVER-GROUP MESSAGING SYSTEM FOR INTERACTIVE APPLICATIONS
First Named Inventor/Applicant Name:	5,822,523
Customer Number:	21839
Filer:	Charles F. Wieland III/Christine Becker
Filer Authorized By:	Charles F. Wieland III
Attorney Docket Number:	0078494-000001
Receipt Date:	03-FEB-2011
Filing Date:	14-JUN-2010
Time Stamp:	11:12:52
Application Type:	Reexam (Patent Owner)

Payment information:

Submitted with Payment	yes
Payment Type	Credit Card
Payment was successfully received in RAM	\$1508
RAM confirmation Number	6356
Deposit Account	024800
Authorized User	WIELAND,CHARLES F.

The Director of the USPTO is hereby authorized to charge indicated fees and credit any overpayment as follows:

Charge any Additional Fees required under 37 C.F.R. Section 1.16 (National application filing, search, and examination fees)

Charge any Additional Fees required under 37 C.F.R. Section 1.17 (Patent application and reexamination processing fees)

Charge any Additional Fees required under 37 C.F.R. Section 1.19 (Document supply fees)
 Charge any Additional Fees required under 37 C.F.R. Section 1.20 (Post Issuance fees)
 Charge any Additional Fees required under 37 C.F.R. Section 1.21 (Miscellaneous fees and charges)

File Listing:

Document Number	Document Description	File Name	File Size(Bytes)/ Message Digest	Multi Part /.zip	Pages (if appl.)
1	Response after non-final action-owner timely	Amendment.pdf	1505304	no	30
			3a6acd945ce05d34ab5e6af21244039e8de317b5		
Warnings:					
Information:					
2	Reexam - Affidavit/Decl/Exhibit Filed by 3rd Party	Declaration.pdf	421021	no	8
			55b08ce52609434abfa2dc4035d028c01bcd95c		
Warnings:					
Information:					
3	Trans Letter filing of a response in a reexam	Amendment_TL.pdf	47006	no	1
			2cec9bcaed7c13b149fb6e22f20462d275954681		
Warnings:					
Information:					
4	Fee Worksheet (PTO-875)	fee-info.pdf	30384	no	2
			0b9daddad8b61587c1f153d88dac8efb571db976		
Warnings:					
Information:					
Total Files Size (in bytes):			2003715		

This Acknowledgement Receipt evidences receipt on the noted date by the USPTO of the indicated documents, characterized by the applicant, and including page counts, where applicable. It serves as evidence of receipt similar to a Post Card, as described in MPEP 503.

New Applications Under 35 U.S.C. 111

If a new application is being filed and the application includes the necessary components for a filing date (see 37 CFR 1.53(b)-(d) and MPEP 506), a Filing Receipt (37 CFR 1.54) will be issued in due course and the date shown on this Acknowledgement Receipt will establish the filing date of the application.

National Stage of an International Application under 35 U.S.C. 371

If a timely submission to enter the national stage of an international application is compliant with the conditions of 35 U.S.C. 371 and other applicable requirements a Form PCT/DO/EO/903 indicating acceptance of the application as a national stage submission under 35 U.S.C. 371 will be issued in addition to the Filing Receipt, in due course.

New International Application Filed with the USPTO as a Receiving Office

If a new international application is being filed and the international application includes the necessary components for an international filing date (see PCT Article 11 and MPEP 1810), a Notification of the International Application Number and of the International Filing Date (Form PCT/RO/105) will be issued in due course, subject to prescriptions concerning national security, and the date shown on this Acknowledgement Receipt will establish the international filing date of the application.



UNITED STATES PATENT AND TRADEMARK OFFICE

UNITED STATES DEPARTMENT OF COMMERCE
United States Patent and Trademark Office
Address: COMMISSIONER FOR PATENTS
P.O. Box 1450
Alexandria, Virginia 22313-1450
www.uspto.gov

APPLICATION NO.	FILING DATE	FIRST NAMED INVENTOR	ATTORNEY DOCKET NO.	CONFIRMATION NO.
90/011,033	06/14/2010	5,822,523	0078494-000001	1686

21839 7590 02/22/2011

BUCHANAN, INGERSOLL & ROONEY PC
POST OFFICE BOX 1404
ALEXANDRIA, VA 22313-1404

EXAMINER

ART UNIT PAPER NUMBER

DATE MAILED: 02/22/2011

Please find below and/or attached an Office communication concerning this application or proceeding.



UNITED STATES PATENT AND TRADEMARK OFFICE

Commissioner for Patents
United States Patent and Trademark Office
P.O. Box 1450
Alexandria, VA 22313-1450
www.uspto.gov

DO NOT USE IN PALM PRINTER

(THIRD PARTY REQUESTER'S CORRESPONDENCE ADDRESS)

NOVAK DRUCE & QUIGG, LLP

(NDQ REEXAMINATION GROUP)

1000 LOUISIANA STREET

FIFTY-THIRD FLOOR

HOUSTON, TX 77002

MAILED

FEB 25 2011

CENTRAL REEXAMINATION UNIT

EX PARTE REEXAMINATION COMMUNICATION TRANSMITTAL FORM

REEXAMINATION CONTROL NO. 90/011,033.

PATENT NO. 5,822,523.

ART UNIT 3992.

Enclosed is a copy of the latest communication from the United States Patent and Trademark Office in the above identified *ex parte* reexamination proceeding (37 CFR 1.550(f)).

Where this copy is supplied after the reply by requester, 37 CFR 1.535, or the time for filing a reply has passed, no submission on behalf of the *ex parte* reexamination requester will be acknowledged or considered (37 CFR 1.550(g)).

Interview Summary	Application No.	Applicant(s)	
	90/011,033	5,822,523	
	Examiner	Art Unit	
	ANDREW L. NALVEN	3992	

All participants (applicant, applicant's representative, PTO personnel):

(1) ANDREW L. NALVEN.

(3) Robert Mukai

Charles Weiland III.

(2) Alex Kosowski

Albert Gagliardi.

(4) Dr. Mayer-Patel.

Date of Interview: 22 February 2011.

Type: a) Telephonic b) Video Conference
c) Personal [copy given to: 1) applicant 2) applicant's representative]

Exhibit shown or demonstration conducted: d) Yes e) No.

If Yes, brief description: Exhibit depicting the functionality of the cited prior art and the claimed invention was shown.

Claim(s) discussed: 1.

Identification of prior art discussed: IRC RFC and Friedman.

Agreement with respect to the claims f) was reached. g) was not reached. h) N/A.

Substance of Interview including description of the general nature of what was agreed to if an agreement was reached, or any other comments: See Continuation Sheet.

(A fuller description, if necessary, and a copy of the amendments which the examiner agreed would render the claims allowable, if available, must be attached. Also, where no copy of the amendments that would render the claims allowable is available, a summary thereof must be attached.)

THE FORMAL WRITTEN REPLY TO THE LAST OFFICE ACTION MUST INCLUDE THE SUBSTANCE OF THE INTERVIEW. (See MPEP Section 713.04). If a reply to the last Office action has already been filed, APPLICANT IS GIVEN A NON-EXTENDABLE PERIOD OF THE LONGER OF ONE MONTH OR THIRTY DAYS FROM THIS INTERVIEW DATE, OR THE MAILING DATE OF THIS INTERVIEW SUMMARY FORM, WHICHEVER IS LATER, TO FILE A STATEMENT OF THE SUBSTANCE OF THE INTERVIEW. See Summary of Record of Interview requirements on reverse side or on attached sheet.

/Andrew L Nalven/
Primary Examiner, Art Unit 3992

Continuation of Substance of Interview including description of the general nature of what was agreed to if an agreement was reached, or any other comments: Patent Owner gave a brief description of the claimed invention. Patent Owner then described the cited prior art, IRC RFC and Friedman, and discussed how the claimed "aggregating" steps differ from Friedman's "packing" steps. Patent Owner further discussed the concept of the claimed unicast network and how it differed from the disclosures of the prior art. Examiner indicated that he would consider the arguments and the response prior to the next office action. A copy of Patent Owner's exhibits are attached to this interview summary.

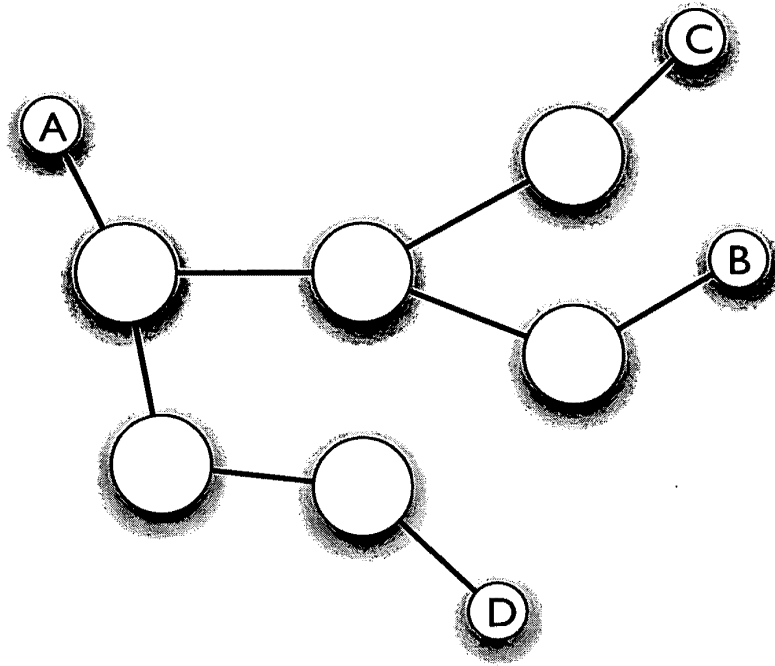

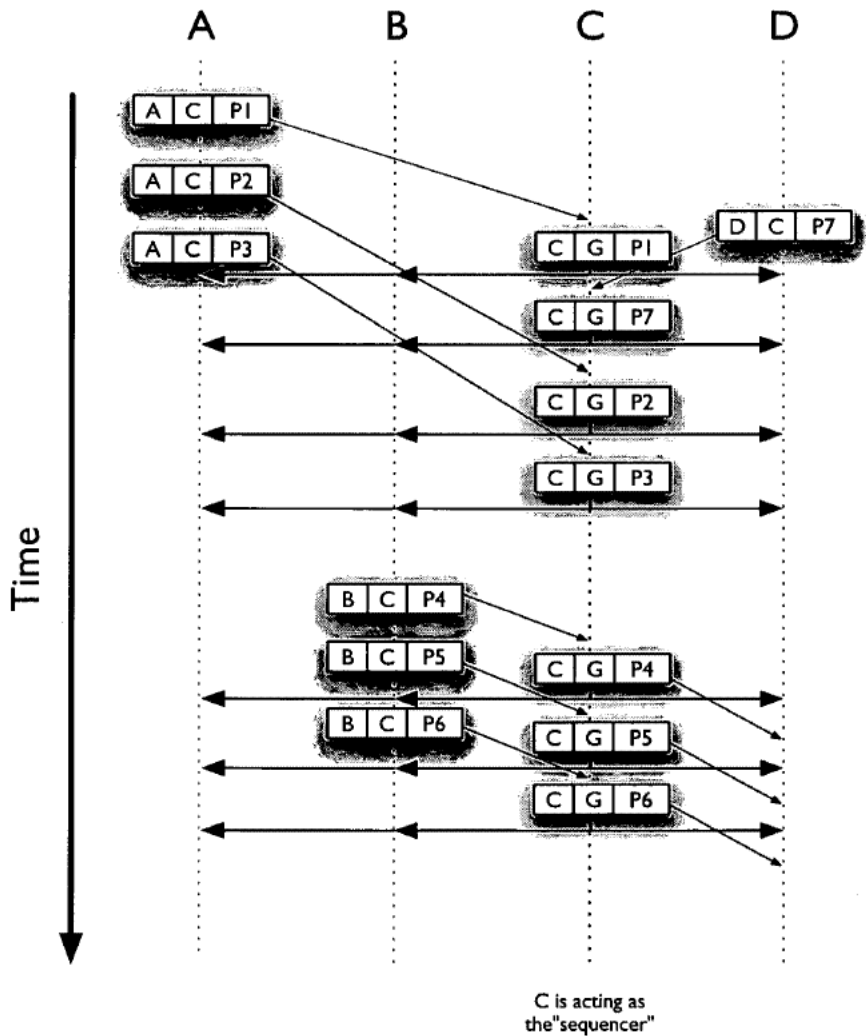

Dynseq Example Timeline

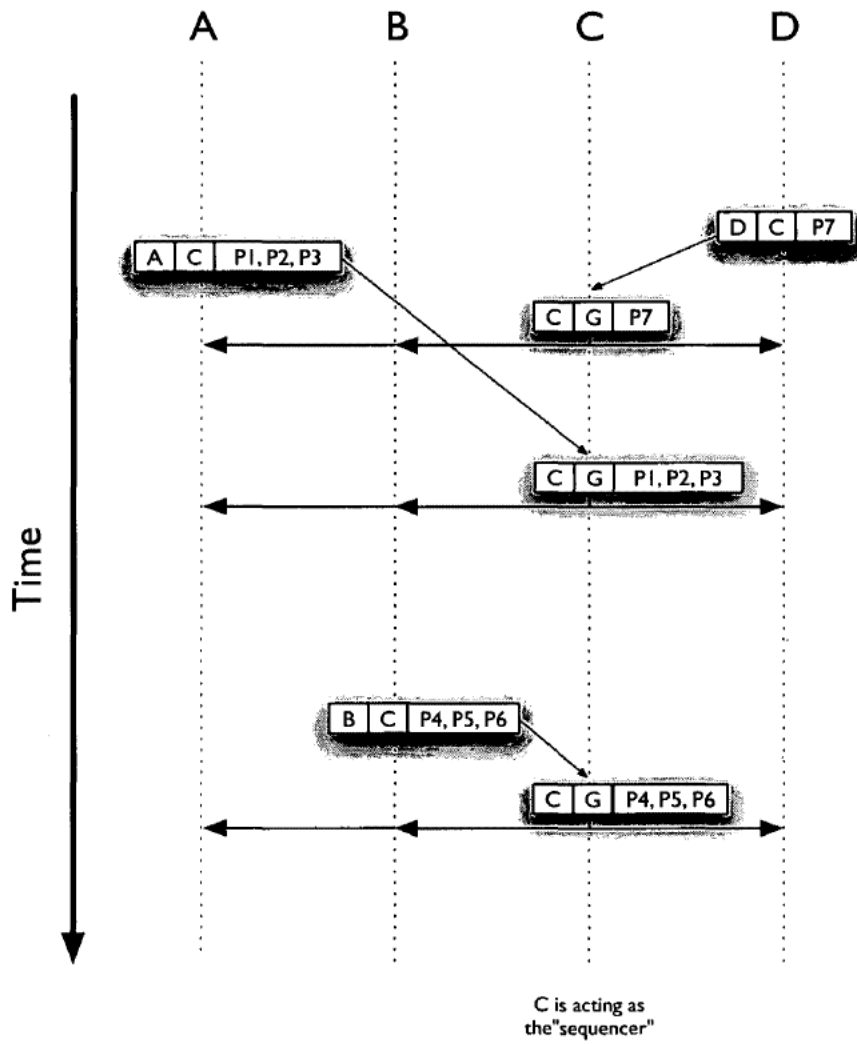

Dysfc Example Timeline

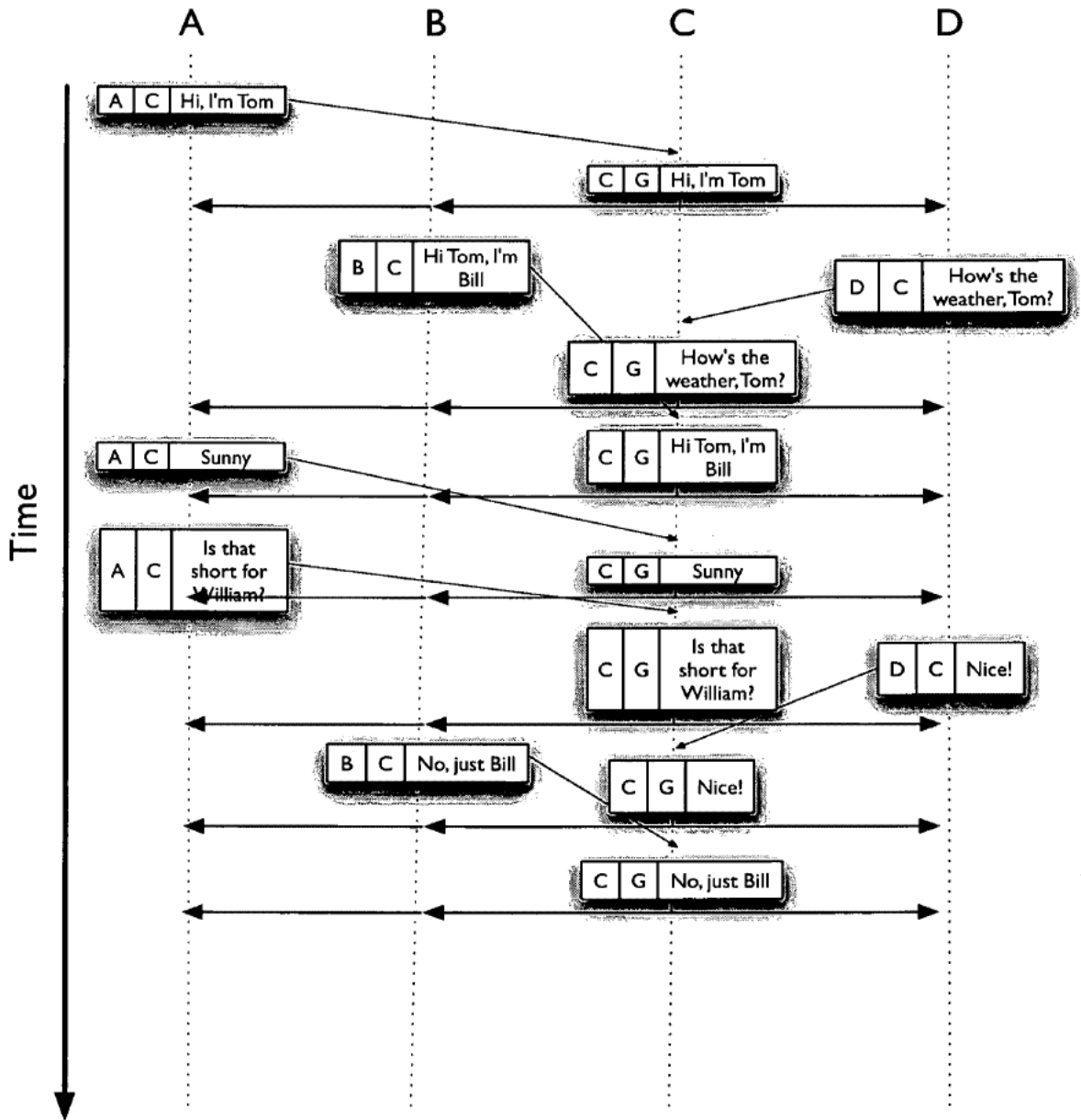

C is acting as the "sequencer"
 but to no real effect because conversational
 causality serves to make messages meaningful.

Dynseq Chat Example Timeline

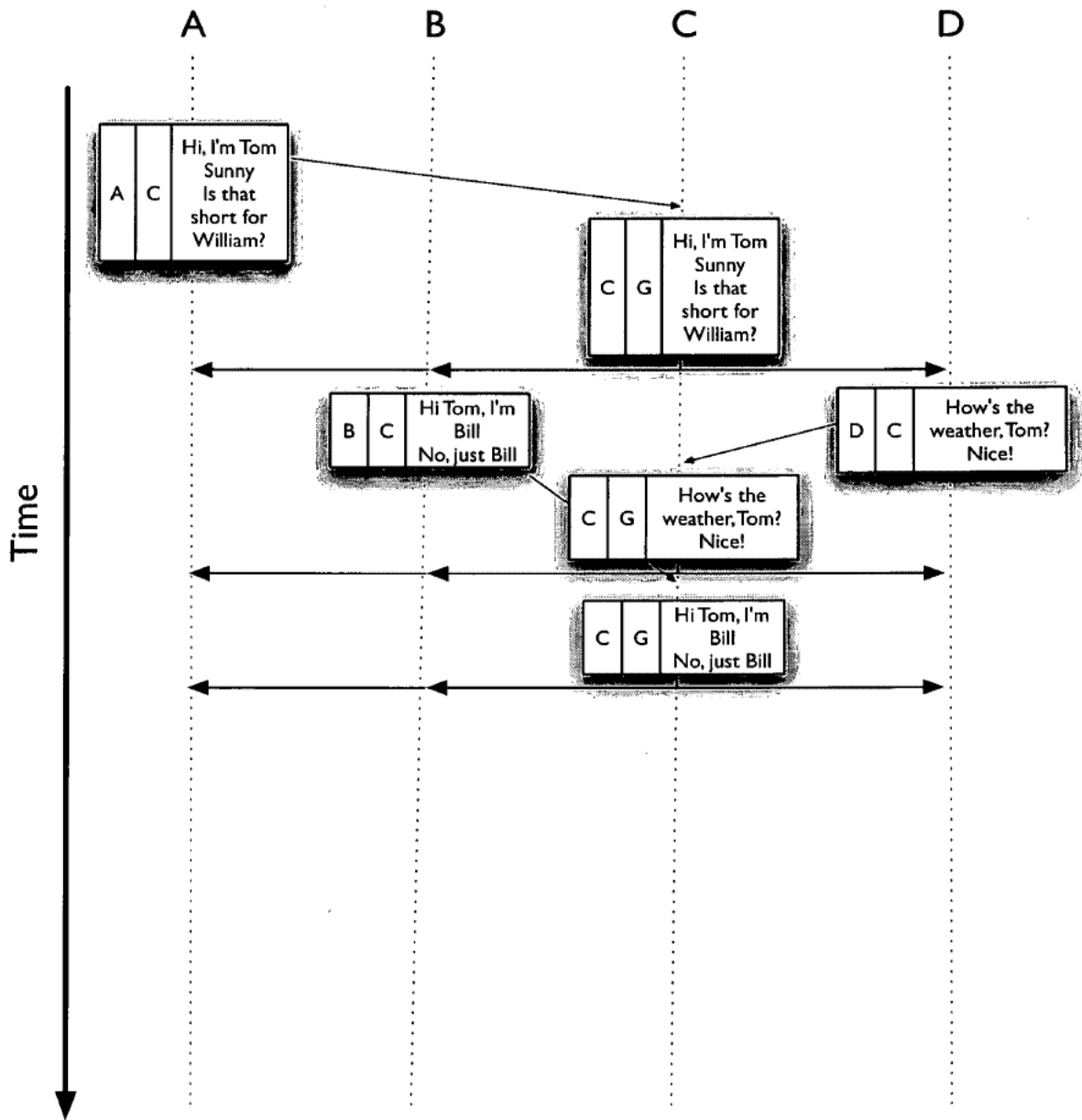

C is acting as the "sequencer" but conversational causality is impossible.

Dysfc Chat Example Timeline

IN THE UNITED STATES PATENT AND TRADEMARK OFFICE

In re Reexamination of)	MAIL STOP EX PARTE
)	REEXAMINATION
U.S. Patent No. 5,822,523)	
)	Group Art Unit: 3992
Jeffrey J. Rothschild et al.)	
)	Examiner: Andrew Nalven
Issued: October 13, 1998)	
)	Confirmation No.: 1686
Reexamination Control No.: 90/011,033)	
)	
For: SERVER-GROUP MESSAGING)	
SYSTEM FOR INTERACTIVE)	
APPLICATIONS)	

SUMMARY OF INTERVIEW

The Patent Owner wishes to thank Examiners Andrew Nalven, Alexander Kosowski and Albert Gagliardi for the courtesies extended during the personal interview of February 22, 2011, to the undersigned, Mr. Robert Mukai and Dr. Ketan Mayer-Patel, an expert in network operating systems and multimedia computing who submitted his Declaration in this matter with the Amendment filed February 3, 2011.

Robert Mukai began the meeting with introductions and an overview of the Agenda. He explained that the commercial significance of the invention to the interactive online gaming arts and identified related litigation. He explained that the litigation against Microsoft settled to the financial benefit of the Patent Owner, and that there is ongoing litigation against Sony and Activision, from which it is assumed the present reexamination proceeding stems.

The undersigned then outlined the significance of the technology starting with a short outline of the Background section of the present patent in reexamination (the '523 Patent). This summary emphasized the problems created by multiple communications, first by pointing out that the prior art unicast system realized multiple communications from a host, i.e., one message to each other host in a

messaging group, and the need for each host to receive multiple messages from other hosts in a message group to maintain the game state. The undersigned then explained the meaning of multicasting, which reduces the number of messages sent, but not the number of messages received (See, '529, col. 6, lines 61-65) and requires routers in a network to maintain dynamic lists of messaging group members, but raises list propagation issues. See, '529, col. 6, lines 15-60.

It was emphasized that in this context the invention was created, but that the original independent claim does not recite interactive gaming *per se*. Newly presented claims, however, do bring out various aspects associated with interactive online games.

The undersigned then briefly outlined the principles for the arguments by explaining that the cited Friedman document was a multicast system which has as a primary objective "total ordering". To adopt the suggested combination would require that the fundamental principles of operation of one or both of the applied documents would be ignored. It was explained such circumstances mandated that a *prima facie* case of obviousness could not be established.

It was also pointed out that the party requesting the reexamination mischaracterized the Friedman document as disclosing the "aggregation" of payloads from a plurality of hosts in a server, when it in fact discloses only the "packing" of payloads in a message before the message is formed and sent by a host. See, *e.g.*, p. 5 thereof. Hence, the rejection was based on a misunderstanding of the applied art.

The undersigned also explained that the combination of documents is counterintuitive when one considers the totality of the teachings. Hence, there is no valid reason for the hypothetical combination.

Professor Mayer-Patel then discussed the technology with reference to a series of demonstratives, reproduced below.

The first figure is a generic version of Figs. 3 and 5 of the '523 patent, and was referenced a few times to explain where events were occurring in a network, noting hosts A, B, C, D connected by a network of servers (unlabeled).

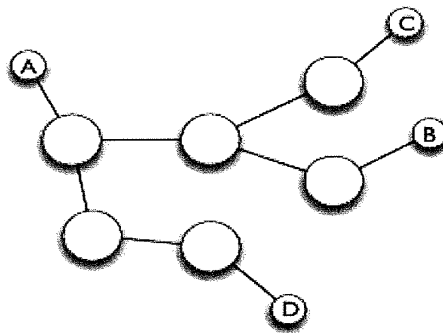

In a second figure, Professor Mayer-Patel explained the operation of Dynseq as described in the Friedman document by way of an exemplary timeline. He explained that host A, for example, sent a series of messages having payloads P1, P2 and P3, and in the meantime host D sent a message with a payload P7. Host C, in its capacity as a "sequencer" in accordance with the Friedman document, then multicasts the message, as represented by the heavy lines, to the other hosts, including the hosts that sent the message and locally to itself, in the "total order" (i.e.,

so that each host receives the same messages in the same order) through a broadcast over an IP Multicasting System.

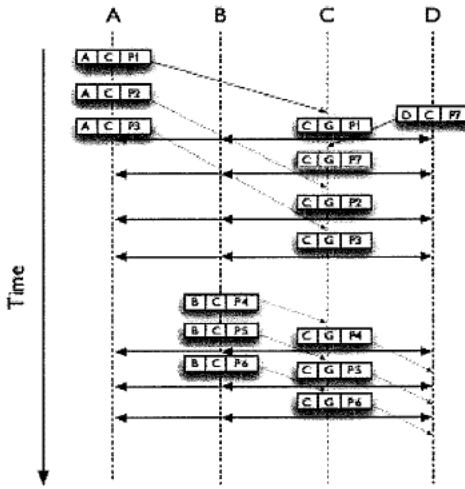

Dynseq Example Timeline

Professor Mayer-Patel next explained a variation of Dynseq identified in the Friedman document as Dysfc by way of another example timeline.

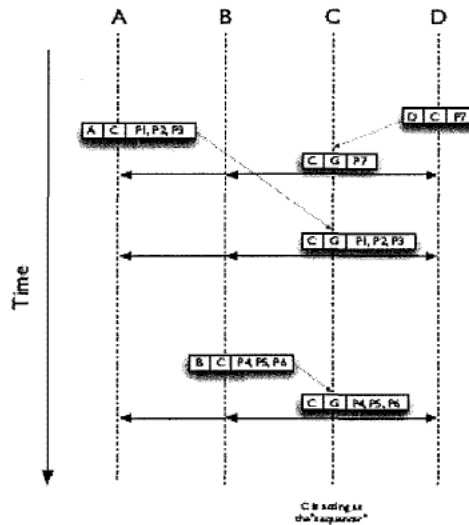

Dysfc Example Timeline

Here, Host A "packs" a few messages P1, P2, P3 into a single payload if these messages are generated within 1 millisecond, e.g., 1 millisecond. It was emphasized that a single host "packs" only its own messages.

With this figure, Professor Mayer-Patel explained the concept of a host "packing" messages to form a payload of one "packed message" to be sent, and contrasted it with "aggregating" messages by a server in which a plurality of messages transmitted from various hosts are received, the payloads are then aggregated and sent out as a single message. It must be noted that "messages" of the packed message in Friedman are not the same as "messages" in the original claims. The claimed "messages" of the original claims might be thought of as being

more equivalent to a "packed message" of Friedman.¹ Mr. Mukai read portions of claim 1 that supported the above meaning of "aggregating" messages from a plurality of hosts.

With regard to the hypothetical application of the Dynseq system of packed messages to the Internet Relay Chat System of the IRC RFC document, Professor Mayer-Patel explored how the IRC RFC document might look if the chat messages were packed messages in accordance with Friedman, using a Dynseq chat example timeline. In this regard, it was noted several times that the millisecond time frames of Friedman are inapplicable to a human chat context, where messages occur over minutes, or even hours or days. The point of this figure was to set up an understanding of the next figure.

¹ This was raised during the interview by way of an example ("an avatar squats and shoots", with both actions being identified in a message).

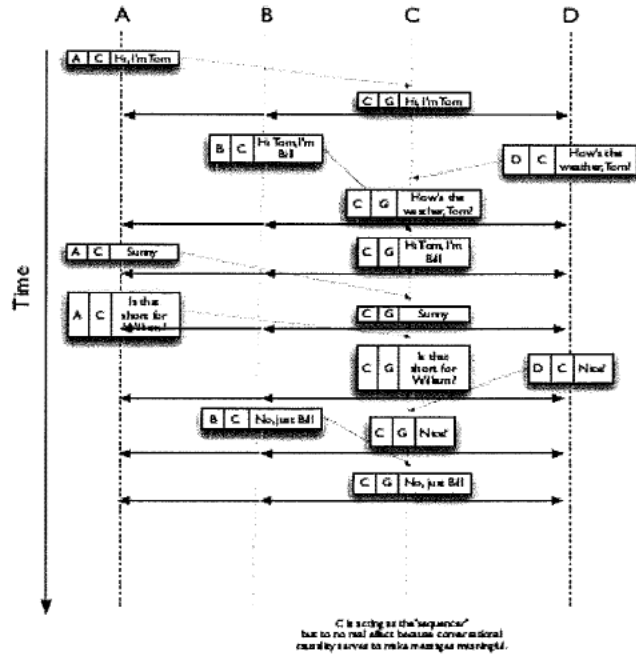

Dynseq Chat Example Timeline

Professor Mayer-Patel then explained how using total ordering with packed messages made no sense at all, in that the packing of total ordered messages would require answers to questions be sent before the questions are asked.

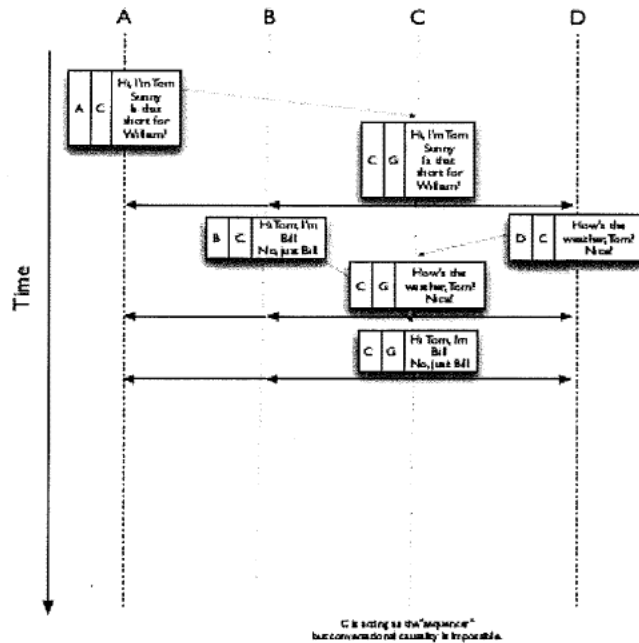

Dysfc Chat Example Timeline

Here, process A would provide answer "sunny" to process D's question "How's the weather, Tom?" before process D asked the question or knew Tom's name.

Examiner Nalven asked why the packing process of Friedman could not be used at the server level. It was pointed out that the applied documents did not teach this, but rather only the disclosure of the '523 patent did. Thus, to apply this teaching would require the improper use of hindsight reconstruction of the Patent Owner's invention based on its own teachings. See, e.g., *KSR Int'l Co. v. Teleflex Inc.*, 550 U.S. 398 (2007) (recognizing hindsight bias and *ex post* reasoning are inappropriate in a determination of obviousness) and MPEP 2142 (citation not mentioned at the

interview). Also, of course, because chats are comparatively slow, it would seem unlikely that there would be an advantage to using this mechanism to reduce transmission/receipt overhead, or that any such reduction would offset the required added complexity and need for additional processing.

At the conclusion of the interview, the undersigned said that this summary would be filed promptly and that in the related reexamination (Control No. 90/011,036) the Office Action of February 10, 2011, had been sent to the wrong firm and had just been downloaded. The Patent Owner will try to respond without requesting that these days be restored, but the documents applied in the related reexamination raise questions regarding status as a publication, which might take additional time to fully explore.

Favorable action on the merits is respectfully requested. Should the Examiner have any additional or residual issues to address, he is invited to contact the undersigned at the number listed below.

Respectfully submitted,

BUCHANAN INGERSOLL & ROONEY PC

Date: March 8, 2011

By:



Charles F. Wieland III
Registration No. 33096

Customer No. 21839
703 836 6620

CERTIFICATE OF SERVICE

It is hereby certified by the undersigned that a true copy of the Information for Interview in Reexamination Control No. 90/011,033 filed on February 22, 2011 and foregoing Summary of Interview filed herewith were sent via e-mail to:

NOVAK DRUCE + QUIGG, LLP
(NDQ Reexamination Group)
1000 Louisiana Street
53rd Floor
Houston, Texas 77002

on this 8th day of March, 2011.

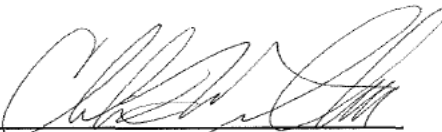

Charles F. Wieland III
Registration No. 33096

Electronic Acknowledgement Receipt

EFS ID:	9606420
Application Number:	90011033
International Application Number:	
Confirmation Number:	1686
Title of Invention:	SERVER-GROUP MESSAGING SYSTEM FOR INTERACTIVE APPLICATIONS
First Named Inventor/Applicant Name:	5,822,523
Customer Number:	21839
Filer:	Charles F. Wieland III/Christine Becker
Filer Authorized By:	Charles F. Wieland III
Attorney Docket Number:	0078494-000001
Receipt Date:	08-MAR-2011
Filing Date:	14-JUN-2010
Time Stamp:	08:41:13
Application Type:	Reexam (Patent Owner)

Payment information:

Submitted with Payment	no
------------------------	----

File Listing:

Document Number	Document Description	File Name	File Size(Bytes)/ Message Digest	Multi Part /.zip	Pages (if appl.)
1	Applicant summary of interview with examiner	001_Summary_of_Interview.pdf	333871 d2085067e1d0bd875b8550886ff19a4825a9078	no	9

Warnings:

Information:

2	Reexam Certificate of Service	001_Cert_of_Serv.pdf	20243 7cbce3911ed136f4e02d8bd6ebdc99ba43177d06	no	1
Warnings:					
Information:					
Total Files Size (in bytes):				354114	
<p>This Acknowledgement Receipt evidences receipt on the noted date by the USPTO of the indicated documents, characterized by the applicant, and including page counts, where applicable. It serves as evidence of receipt similar to a Post Card, as described in MPEP 503.</p> <p><u>New Applications Under 35 U.S.C. 111</u> If a new application is being filed and the application includes the necessary components for a filing date (see 37 CFR 1.53(b)-(d) and MPEP 506), a Filing Receipt (37 CFR 1.54) will be issued in due course and the date shown on this Acknowledgement Receipt will establish the filing date of the application.</p> <p><u>National Stage of an International Application under 35 U.S.C. 371</u> If a timely submission to enter the national stage of an international application is compliant with the conditions of 35 U.S.C. 371 and other applicable requirements a Form PCT/DO/EO/903 indicating acceptance of the application as a national stage submission under 35 U.S.C. 371 will be issued in addition to the Filing Receipt, in due course.</p> <p><u>New International Application Filed with the USPTO as a Receiving Office</u> If a new international application is being filed and the international application includes the necessary components for an international filing date (see PCT Article 11 and MPEP 1810), a Notification of the International Application Number and of the International Filing Date (Form PCT/RO/105) will be issued in due course, subject to prescriptions concerning national security, and the date shown on this Acknowledgement Receipt will establish the international filing date of the application.</p>					

IN THE UNITED STATES PATENT AND TRADEMARK OFFICE

In re Reexamination of)	MAIL STOP REEXAMINATION
U.S. Patent No. 5,822,523)	Group Art Unit: 3992
Jeffrey J. Rothschild et al.)	Examiner: Andrew Nalven
Issued: October 13, 1998)	Confirmation No.: 1686
Reexamination Control No.: 90/011,033)	Information Disclosure Statement Under
For: SERVER-GROUP MESSAGING)	37 C.F.R. § § 1.97, 1.98 and 1.555
SYSTEM FOR INTERACTIVE)	
APPLICATIONS)	

FOURTH INFORMATION DISCLOSURE STATEMENT

Commissioner for Patents
P.O. Box 1450
Alexandria, VA 22313-1450

Sir:

The document cited on the attached form, PTO-1449, is being called to the attention of the Examiner. This document is an Order of the Court in *Paltalk Holdings, Inc. v. Sony Computer Entertainment America, Inc., et al.*, Civil Action No. 2:09-CV-274-DF-CE, filed on April 5, 2011. This Order provides the court's claim construction of the subject patent.

Applicant believes that no fee is required for submission of this statement. However, if a fee is required, the Commissioner is authorized to deduct such fee from the undersigned's Deposit Account No. 02-4800.

Respectfully submitted,

BUCHANAN INGERSOLL & ROONEY PC

Date: April 18, 2011

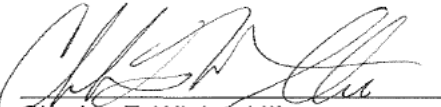
By: 
Charles F. Wieland III
Registration No. 33096

Customer No. 21839
703 836 6620

CERTIFICATE OF SERVICE

It is hereby certified by the undersigned that a true copy of the foregoing Fourth Information Disclosure Statement and PTO-1449 Form were transmitted via e-mail (patentreexam@novakdruce.com) to:

NOVAK DRUCE + QUIGG, LLP
(NDQ Reexamination Group)
1000 Louisiana Street
53rd Floor
Houston, Texas 77002

on this 18th day of April, 2011.



Charles F. Wieland III
Registration No. 33096

**FOURTH
INFORMATION DISCLOSURE
STATEMENT BY APPLICANT**

(use as many sheets as necessary)

In re Reexamination of U.S. Patent No. / Control No.:	5,822,523/90/011,033
Issue Date	October 13, 1998
First Named Inventor	Jeffrey J. Rothschild et al.
Confirmation/Group Art Unit No.	1686 / 3992
Attorney Docket No.	0078494-000001

Sheet 1 of 1

U.S. PATENT DOCUMENTS

Examiner Initials	Document Number-Kind Code	Publication Date MM-DD-YYYY	Name of Patentee or Applicant of Cited Document	Pages, Columns, Lines Where Relevant Passages or Figures Appear
	US-			
	US-			
	US-			
	US-			
	US-			
	US-			
	US-			
	US-			
	US-			
	US-			

FOREIGN PATENT DOCUMENTS

Examiner Initials	Foreign Patent Document		Name of Patentee or Applicant of Cited Document	STATUS						
	Country Code ¹ , Number, Kind Code	Publication Date (MM-DD-YYYY)		Translation	Partial Translation	Eng. Lang. Summary	Search Report	IPER	Abstract	Cited in Spec. / Pg. No(s).

¹Enter Office that issued the document, by the two-letter code.

NON-PATENT LITERATURE DOCUMENTS

Examiner Initials	Include name of the author (in CAPITAL LETTERS), title of the article (when appropriate), title of the item (book, magazine, journal, serial, symposium, catalog, etc.), date, page(s), volume-issue number(s), publisher, city and/or country where published.
	Memorandum Opinion and Order, Dated April 5, 2011, filed in Paltalk Holdings, Inc. v. Sony Computer Entertainment America, Inc., et al., United States District Court for the Eastern District of Texas-Marshall Division, Case No. 2:09-CV-274-DF-CE

Examiner Signature	Date Considered
--------------------	-----------------

*EXAMINER: Initial if reference considered, whether or not citation is in conformance with M.P.E.P. § 609. Draw line through citation if not in conformance and not considered. Include copy of this form with next communication to Applicant.

Electronic Acknowledgement Receipt

EFS ID:	9902737
Application Number:	90011033
International Application Number:	
Confirmation Number:	1686
Title of Invention:	SERVER-GROUP MESSAGING SYSTEM FOR INTERACTIVE APPLICATIONS
First Named Inventor/Applicant Name:	5,822,523
Customer Number:	21839
Filer:	Charles F. Wieland III/Monica Pogue
Filer Authorized By:	Charles F. Wieland III
Attorney Docket Number:	0078494-000001
Receipt Date:	18-APR-2011
Filing Date:	14-JUN-2010
Time Stamp:	16:55:23
Application Type:	Reexam (Patent Owner)

Payment information:

Submitted with Payment	no
------------------------	----

File Listing:

Document Number	Document Description	File Name	File Size(Bytes)/ Message Digest	Multi Part /.zip	Pages (if appl.)
1	Transmittal Letter	001IDSREEXAM.pdf	119087 a104d2e5e6a588f5a8b1f8c50b5d86c89db e6c09	no	3

Warnings:

Information:

2	NPL Documents	001IDSMEMO.pdf	328435 3de04054cce64a051274eee7e72aa1bbe4d94846	no	29
Warnings:					
Information:					
Total Files Size (in bytes):			447522		
<p>This Acknowledgement Receipt evidences receipt on the noted date by the USPTO of the indicated documents, characterized by the applicant, and including page counts, where applicable. It serves as evidence of receipt similar to a Post Card, as described in MPEP 503.</p> <p><u>New Applications Under 35 U.S.C. 111</u> If a new application is being filed and the application includes the necessary components for a filing date (see 37 CFR 1.53(b)-(d) and MPEP 506), a Filing Receipt (37 CFR 1.54) will be issued in due course and the date shown on this Acknowledgement Receipt will establish the filing date of the application.</p> <p><u>National Stage of an International Application under 35 U.S.C. 371</u> If a timely submission to enter the national stage of an international application is compliant with the conditions of 35 U.S.C. 371 and other applicable requirements a Form PCT/DO/EO/903 indicating acceptance of the application as a national stage submission under 35 U.S.C. 371 will be issued in addition to the Filing Receipt, in due course.</p> <p><u>New International Application Filed with the USPTO as a Receiving Office</u> If a new international application is being filed and the international application includes the necessary components for an international filing date (see PCT Article 11 and MPEP 1810), a Notification of the International Application Number and of the International Filing Date (Form PCT/RO/105) will be issued in due course, subject to prescriptions concerning national security, and the date shown on this Acknowledgement Receipt will establish the international filing date of the application.</p>					



UNITED STATES PATENT AND TRADEMARK OFFICE

UNITED STATES DEPARTMENT OF COMMERCE
United States Patent and Trademark Office
Address: COMMISSIONER FOR PATENTS
P.O. Box 1450
Alexandria, Virginia 22313-1450
www.uspto.gov

APPLICATION NO.	FILING DATE	FIRST NAMED INVENTOR	ATTORNEY DOCKET NO.	CONFIRMATION NO.
90/011,033	06/14/2010	5,822,523	0078494-000001	1686

21839 7590 05/02/2011

BUCHANAN, INGERSOLL & ROONEY PC
POST OFFICE BOX 1404
ALEXANDRIA, VA 22313-1404

EXAMINER

ART UNIT PAPER NUMBER

DATE MAILED: 05/02/2011

Please find below and/or attached an Office communication concerning this application or proceeding.



DO NOT USE IN PALM PRINTER

(THIRD PARTY REQUESTER'S CORRESPONDENCE ADDRESS)

NOVAK DRUCE & QUIGG, LLP
(NDQ REEXAMINATION GROUP)
1000 LOUISIANA STREET
FIFTY-THIRD FLOOR
HOUSTON, TX 77002

MAILED

MAY 02 2011

CENTRAL REEXAMINATION UNIT

EX PARTE REEXAMINATION COMMUNICATION TRANSMITTAL FORM

REEXAMINATION CONTROL NO. 90/011,033.

PATENT NO. 5,822,523.

ART UNIT 3992.

Enclosed is a copy of the latest communication from the United States Patent and Trademark Office in the above identified *ex parte* reexamination proceeding (37 CFR 1.550(f)).

Where this copy is supplied after the reply by requester, 37 CFR 1.535, or the time for filing a reply has passed, no submission on behalf of the *ex parte* reexamination requester will be acknowledged or considered (37 CFR 1.550(g)).

**Notice of Intent to Issue
Ex Parte Reexamination Certificate**

Control No. 90/011,033	Patent Under Reexamination 5,822,523	
Examiner ANDREW L. NALVEN	Art Unit 3992	

-- The MAILING DATE of this communication appears on the cover sheet with the correspondence address --

1. Prosecution on the merits is (or remains) closed in this *ex parte* reexamination proceeding. This proceeding is subject to reopening at the initiative of the Office or upon petition. Cf. 37 CFR 1.313(a). A Certificate will be issued in view of

- (a) Patent owner's communication(s) filed: 03 February 2011.
- (b) Patent owner's late response filed: _____.
- (c) Patent owner's failure to file an appropriate response to the Office action mailed: _____.
- (d) Patent owner's failure to timely file an Appeal Brief (37 CFR 41.31).
- (e) Other: _____.

Status of *Ex Parte* Reexamination:

- (f) Change in the Specification: Yes No
- (g) Change in the Drawing(s): Yes No
- (h) Status of the Claim(s):
 - (1) Patent claim(s) confirmed: 1-6.
 - (2) Patent claim(s) amended (including dependent on amended claim(s)): _____
 - (3) Patent claim(s) canceled: _____.
 - (4) Newly presented claim(s) patentable: 9-49.
 - (5) Newly presented canceled claims: 7 and 8.
 - (6) Patent claim(s) previously currently disclaimed: _____
 - (7) Patent claim(s) not subject to reexamination: _____.

2. Note the attached statement of reasons for patentability and/or confirmation. Any comments considered necessary by patent owner regarding reasons for patentability and/or confirmation must be submitted promptly to avoid processing delays. Such submission(s) should be labeled: "Comments On Statement of Reasons for Patentability and/or Confirmation."

3. Note attached NOTICE OF REFERENCES CITED (PTO-892).

4. Note attached LIST OF REFERENCES CITED (PTO/SB/08 or PTO/SB/08 substitute).

5. The drawing correction request filed on _____ is: approved disapproved.

6. Acknowledgment is made of the priority claim under 35 U.S.C. § 119(a)-(d) or (f).

- a) All b) Some* c) None of the certified copies have
 - been received.
 - not been received.
 - been filed in Application No. _____.
 - been filed in reexamination Control No. _____.
 - been received by the International Bureau in PCT Application No. _____.

* Certified copies not received: _____.

7. Note attached Examiner's Amendment.

8. Note attached Interview Summary (PTO-474).

9. Other: _____.

/Andrew L Nalven/
Primary Examiner, Art Unit 3992

cc: Requester (if third party requester)

U.S. Patent and Trademark Office

PTOL-469 (Rev. 05-10)

Notice of Intent to Issue Ex Parte Reexamination Certificate

Part of Paper No 20110418

NOTICE OF INTENT TO ISSUE REEXAMINATION CERTIFICATE

The following Office Action is in response to the Patent Owner's response submitted February 3, 2011.

I. Summary of the Reexamination Proceeding

1. Reexamination was granted as to claims 1-6 on July 29, 2010.
2. Claims 1-6 were rejected in a non-final rejection on December 3, 2010.
3. Patent Owner responded to the December 3, 2010 rejection by traversing the rejections and adding new claims 7-49.

II. Status of the Claims

1. Original claims 1-6 are confirmed.
2. Newly added claims 9-49 are patentable.
3. Newly added claims 7 and 8 are canceled pursuant to an Examiner's Amendment found below.

III. Examiner's Amendment

An examiner's amendment to the record appears below. The changes made by this examiner's amendment will be reflected in the reexamination certificate to issue in due course. The following Examiner's Amendment was authorized by Charles F. Wieland III (Reg No.

Art Unit: 3992

33096).

New Claim 7 is canceled.

New Claim 8 is canceled.

IV. STATEMENT OF REASONS FOR PATENTABILITY AND/OR CONFIRMATION

The following is an examiner's statement of reasons for patentability and/or confirmation of the claims found patentable in this reexamination proceeding:

The prior art cited in the Request, alone or in combination, fails to teach the claimed feature of "aggregating, by said server in a time interval determined in accordance with a predefined criterion, said payload portions of said messages to create an aggregated payload."

For example, Friedman teaches a total ordering protocol where messages are buffered and then sent out as an aggregated message (*Friedman, Page 5*). However, Friedman's buffering takes place at the host computer instead of the claimed group messaging server. Accordingly, Friedman fails to teach aggregating, *by said server* in a time interval determined in accordance with a predefined criterion, said payload portions of said messages to create an aggregated payload.

Further, the Netrek reference fails to teach aggregating, by said server in a time interval determined in accordance with a predefined criterion, said payload portions of said messages to create an aggregated payload. Netrek is a multiplayer game where users join teams and participate in a space war game. Netrek teaches that each user sends its commands to the group

Art Unit: 3992

messaging server. However, Netrek differs in that the payload messages are not explicitly aggregated into an aggregated message. Instead, the group messaging server processes the received commands and sends out a status update to all of the players informing them of the change in game play. The commands sent to the group messaging server are not stripped of their payloads and aggregated. Accordingly, Netrek fails to teach aggregating, by said server in a time interval determined in accordance with a predefined criterion, said payload portions of said messages to create an aggregated payload.

The remaining references, Ring, IRC RFC, Van Hook, DIS, Suzuki, McFadden, and Macedonia similarly do not teach the claimed feature of aggregating, by said server in a time interval determined in accordance with a predefined criterion, said payload portions of said messages to create an aggregated payload. Accordingly, the prior art cited by the Request fails to anticipate or render obvious the claims of the '523 patent.

Any comments considered necessary by PATENT OWNER regarding the above statement must be submitted promptly to avoid processing delays. Such submission by the patent owner should be labeled: "Comments on Statement of Reasons for Patentability and/or Confirmation" and will be placed in the reexamination file.

CORRESPONDENCE

All correspondence relating to this ex parte reexamination proceeding should be directed:

By EFS: Registered users may submit via the electronic filing system EFS-Web, at <https://portal.uspto.gov/authenticate/authenticateuserlocalepf.html>.

By Mail to: Mail Stop *Ex Parte* Reexam
Central Reexamination Unit
Commissioner for Patents
United States Patent & Trademark Office
P.O. Box 1450
Alexandria, VA 22313-1450

By FAX to: (571) 273-9900
Central Reexamination Unit

By hand: Customer Service Window
Randolph Building
401 Dulany Street
Alexandria, VA 22314

For EFS-Web transmissions, 37 CFR 1.8(a)(1)(i) (C) and (ii) states that correspondence (except for a request for reexamination and a corrected or replacement request for reexamination) will be considered timely filed if (a) it is transmitted via the Office's electronic filing system in accordance with 37 CFR 1.6(a)(4), and (b) includes a certificate of transmission for each piece of correspondence stating the date of transmission, which is prior to the expiration of the set period of time in the Office action.

Application/Control Number: 90/011,033

Page 6

Art Unit: 3992

Any inquiry concerning this communication or earlier communications from the Examiner, or as to the status of this proceeding, should be directed to the Central Reexamination Unit at telephone number (571) 272-7705.

Signed:

/Andrew Nalven/

Andrew Nalven
CRU Examiner
GAU 3992
(571) 272-3839

Conferee: ESK

Conferee: apj

Substitute for form 1449/PTO & 1449B/PTO

Complete if Known

**SECOND
INFORMATION DISCLOSURE
STATEMENT BY APPLICANT**

(use as many sheets as necessary)

In re Reexamination of U.S. Patent No. / Control No.:	5,822,523 / 90/011,033
Issue Date:	October 13, 1998
First Named Inventor	Jeffrey J. Rothschild et al.
Confirmation/Group Art Unit No.	1686 / 3992
Attorney Docket No.	0078494-000001

Sheet 1 of 9

U.S. PATENT DOCUMENTS

Exmr. Initials	Ref. No.	Document Number- Kind Code	Publication/Issue Date MM-DD-YYYY	Name of Patentee or Applicant of Cited Document	Pages, Columns, Lines Where Relevant Passages or Figures Appear
ESK		4,572,509	02-1986	SITRICK	
		4,740,954	04-1988	COTTON et al.	
		4,807,224	02-1989	NARON et al.	
		4,984,235	01-1991	HILLIS et al.	
		4,991,171	02-1991	TERASLINNA et al.	
		4,998,199	03-1991	TASHIRO et al.	
		5,079,767	01-1992	PERLMAN	
		5,083,800	01-1992	LOCKTON	
		5,089,813	02-1992	DELUCA et al.	
		5,117,420	05-1992	HILLIS et al.	
		5,150,410	09-1992	BERTRAND	
		5,150,464	09-1992	SIDHU et al.	
		5,245,608	09-1993	DEATON, JR. et al.	
		5,257,113	10-1993	CHEN et al.	
		5,287,530	02-1994	DAVIS et al.	
		5,289,460	02-1994	DRAKE, JR. et al.	
		5,297,143	03-1994	FRIDRICH et al.	
		5,309,433	05-1994	CIDON et al.	
		5,309,437	05-1994	PERLMAN et al.	
		5,329,619	07-1994	PAGE et al.	
		5,361,256	11-1994	DOERINGER et al.	
		5,365,523	11-1994	DERBY et al.	
		5,408,261	04-1995	KAMATA et al.	
		5,418,912	05-1995	CHRISTENSON	
		5,430,727	07-1995	CALLON	
		5,453,780	09-1995	CHEN et al.	
		5,475,819	12-1995	MILLER et al.	
		5,481,735	01-1996	MORTENSEN et al.	
		5,502,726	03-1996	FISCHER	
		5,517,494	05-1996	GREEN	
		5,558,339	09-1996	PERLMAN	
		5,581,552	12-1996	CIVANLAR et al.	
	5,586,257	12-1996	PERLMAN		
	5,586,937	12-1996	MENASHE		
	5,590,281	12-1996	STEVENS		
	5,594,732	01-1997	BELL et al.		
	5,630,757	05-1997	GAGIN et al.		
	5,634,011	05-1997	AUERBACH et al.		
	5,674,127	10-1997	HORSTMANN et al.		
	5,685,775	11-1997	BAKOGLU et al.		
	5,729,540	03-1998	WEGRZYN		

Examiner Signature	<i>E. Paul to Valva</i>	Date Considered	1 MAY 2011
--------------------	-------------------------	-----------------	------------

*EXAMINER: Initial if reference considered, whether or not citation is in conformance with M.P.E.P. § 609. Draw line through citation if not in conformance and not considered. Include copy of this form with next communication to Applicant.

**SECOND
INFORMATION DISCLOSURE
STATEMENT BY APPLICANT**

(use as many sheets as necessary)

Sheet 2 of 9

In re Reexamination of U.S. Patent No. / Control No.:	5,822,523 / 90/011,033
Issue Date:	October 13, 1998
First Named Inventor	Jeffrey J. Rothschild et al.
Confirmation/Group Art Unit No.	1686 / 3992
Attorney Docket No.	0078494-000001

ESK	5,740,170	04-1998	ANDOU et al.
	5,740,231	04-1998	COHN et al.
	5,761,436	06-1998	NIELSEN
	5,778,187	07-1998	MONTEIRO et al.
	5,784,668	06-1998	NEEDHAM
	5,805,830	09-1998	REESE et al.
	5,812,552	09-1998	ARORA et al.
	5,930,259	07-1999	KATSUBE et al.
	5,946,308	08-1999	DOBBINS et al.
✓	5,956,485	09-1999	PERLMAN

FOREIGN PATENT DOCUMENTS

Exmr. Initials	Ref. No.	Foreign Patent Document		Name of Patentee or Applicant of Cited Document	STATUS							
		Country Code ¹ , Number, Kind Code	Publication Date (MM-DD-YYYY)		Translation	Partial Translation	Eng. Lang. Summary	Search Report	IPER	Abstract	Cited in Spec. / Pg. No(s).	
ESK		EP 0 637 149	02-1995	DIGITAL EQUIPMENT CORP.								
		WO 93/15572	08-1993	NELLCOR INC.								
		WO 95/10911	04-1995	INTEL CORP.								
		WO 95/10908	04-1995	INTEL CORP.								

¹Enter Office that issued the document, by the two-letter code.

NON-PATENT LITERATURE DOCUMENTS

Include name of the author (in CAPITAL LETTERS), title of the article (when appropriate), title of the item (book, magazine, journal, serial, symposium, catalog, etc.), date, page(s), volume-issue number(s), publisher, city and/or country where published.

Exmr. Initials	Ref. No.	Include name of the author (in CAPITAL LETTERS), title of the article (when appropriate), title of the item (book, magazine, journal, serial, symposium, catalog, etc.), date, page(s), volume-issue number(s), publisher, city and/or country where published.
ESK		AHUJA, S.R., et al., "The Rapport Multimedia Conferencing System," Conference on Office Information Systems 1988, pp. 1-7.
		ARMSTRONG, S. et al., "Multicast Transport Protocol," Network Working Group Request For Comments: 1301, 1992, 31 pages.
		BERGLUND, E.J. et al. "Amaze: A Distributed Multi-Player Game Program using the Distributed V Kernel," IEEE Proceedings of the Fourth Int'l Conf. on Distributed Systems, 1984, pp. 248-253.
		BRADEN, R. (ed.), "Requirements for Internet Hosts-Communication Layers," Network Working Group Request for Comments: 1122, Oct. 1989, 100 pages.
		BRADEN, R. (ed.), "Requirements for Internet Hosts-Application and Support," Network Working Group Request for Comments: 1123, Oct. 1989, 84 pages.
		BRADEN, R. et al., "Integrated Services in the Internet Architecture: An Overview," Network Working Group Request for Comments: 1633, Jun. 1994, 27 pages.
✓		BRAUDES, R. et al., "Requirements for Multicast Protocols," Network Working Group Request for Comments: 1458, 05-1993, 16 pages.

Examiner Signature	<i>Eric Pearl for Nelson</i>	Date Considered	1/19/2011
--------------------	------------------------------	-----------------	-----------

*EXAMINER: Initial if reference considered, whether or not citation is in conformance with M.P.E.P. § 609. Draw line through citation if not in conformance and not considered. Include copy of this form with next communication to Applicant.

**SECOND
INFORMATION DISCLOSURE
STATEMENT BY APPLICANT**

(use as many sheets as necessary)

Sheet 3 of 9

In re Reexamination of U.S. Patent No. / Control No.:	5,822,523 / 90/011,033
Issue Date:	October 13, 1998
First Named Inventor	Jeffrey J. Rothschild et al.
Confirmation/Group Art Unit No.	1686 / 3992
Attorney Docket No.	0078494-000001

NON-PATENT LITERATURE DOCUMENTS

Include name of the author (in CAPITAL LETTERS), title of the article (when appropriate), title of the item (book, magazine, journal, serial, symposium, catalog, etc.), date, page(s), volume-issue number(s), publisher, city and/or country where published.

ESK	CAMERON, P. et al., "Transport Multiplexing Protocol (TMux)," Network Working Group Request for Comments: 1692, Aug. 1994, 10 pages.
	CHERITON, D.R. et al., "Host Groups: A Multicast Extension for Datagram Internetworks," ACM/IEEE Proceedings of the Ninth Data Communications Symposium, Sep. 10-13, 1985, pp. 172-179.
	CHIMIAK, W., "A Comment on Packet Video Remote Conferencing and the Transport/Network Layers," Network Working Group Request for Comments: 1453, Apr. 1993, 9 pages.
	CROCKER, D.H., "Standard For The Format Of ARPA Internet Text Messages," IETF RFC #822, Aug. 13, 1982, 43 pages.
	DEERING, S.E. et al., "Host Groups: A Multicast Extension to the Internet Protocol," Network Working Group Request for Comments: 966, Dec. 1985, 23 pages.
	DEERING, S., "Host Extensions for IP Multicasting," Network Working Group for Comments: 1054, 05-1988, 16 pages.
	DEERING, S., "Host Extensions for IP Multicasting," Network Working Group Request for Comments: 1112, Aug., 1989, 14 pages.
	HANDLEY, M.J., "The Car System: Multimedia in Support of Collaborative Design," Computing and Control Division Colloquium on "Multimedia and Professional Applications", Feb. 3, 1993, pp. 8/1-8/5.
	HENCKEL, L., "Multipeer Transport Services for Multimedia Applications," High Performance Networking, V: Proc. Of the IFIP TC6/WG6.4 Fifth International Conference on High Performance Networking, Jun. 27-Jul. 1, 1994, pp. 167-184.
	KIRSCH, T. et al., "Communication support for cooperative work," Computer Communications, vol. 16, No. 9, Sep. 1993, pp. 594-602.
	LAUWERS, J.C. et al., "Replicated Architectures for Shared Window Systems: A Critique," Proc. of the ACM Conference on Office Information Systems, 1990, pp. 249-260.
	Leung, Y-W. et al., "Optimum Connection Paths for a Class of Videoconferences," Int'l Conference on Comm. ICC 91, vol. 1 of 3, Jun. 23-26, 1991, pp. 0859-0865.
	LEUNG, Y-W. et al., "A Modular Multirate Video Distributing System-Design and Dimensioning," IEEE/ACM Transactions on Networking, vol. 2, No. 6, Dec. 1994, pp. 549-557.
	LI, Y. et al., "Multipoint Conferencing for Mobile Communications Network," 2.sup.nd Int'l. Conference on Universal Personal Communications, Oct. 12-15, 1993, pp. 212-216.
	Multipoint Control Units For Audiovisual Systems Using Digital Channels Up To 2 Mbit/s, ITU Standard Draft H.231, 1993, pp. 11-22.
	NGOH, L., "Multicast Support for Group Communications," Computer Networks and ISDN Systems, 166-178, Oct. 1991, pp. 166-178.
	POSTEL, J.B., "Simple Mail Transfer Protocol," Internet Engineering Task Force (IETF) Request for Comments (RFC) 821, Aug. 1982, 59 pages.
	RAJAGOPALAN, B., "Membership protocols for distributed conference control," Computer Communications, vol. 18, No. 10, Oct. 1995, pp. 695-708.
	RAMANATHAN, S. et al., "Optimal Communication Architecture for Multimedia Conferencing in Distributed Systems," The 12.sup.th Int'l Conference on Distributed Computing Systems, Jun. 9-12, 1992, pp. 46-53.
	ROSE, M.T. et al., "Proposed Standard for Message Encapsulation," Network Working Group Request for Comments: 934, Jan. 1985, 9 pages.
	SCHAFFER, U., "MPPS-A Multiparty Presentation Service," Upper Layer Protocols, Architectures and Applications: Proc. Of the IFIP TC6/WG6.5 International Conference on Upper Layer Protocols, Architectures and Applications, Jun. 1-3, 1994, pp. 243-256.
V	SCHOOLER, E.M., "The Impact of Scalling on a Multimedia Connection Architecture," ACM Journal of Multimedia Systems, vol. 1, No. 1, 1993, pp. 1-10.

Examiner Signature	<i>E. Z. & Naber</i>	Date Considered	1 MAY 2011
--------------------	--------------------------	-----------------	------------

*EXAMINER: Initial if reference considered, whether or not citation is in conformance with M.P.E.P. § 609. Draw line through citation if not in conformance and not considered. Include copy of this form with next communication to Applicant.

**SECOND
INFORMATION DISCLOSURE
STATEMENT BY APPLICANT**

(use as many sheets as necessary)

Sheet 4 of 9

In re Reexamination of U.S. Patent No. / Control No.:	5,822,523 / 90/011,033
Issue Date:	October 13, 1998
First Named Inventor	Jeffrey J. Rothschild et al.
Confirmation/Group Art Unit No.	1686 / 3992
Attorney Docket No.	0078494-000001

NON-PATENT LITERATURE DOCUMENTS

Include name of the author (in CAPITAL LETTERS), title of the article (when appropriate), title of the item (book, magazine, journal, serial, symposium, catalog, etc.), date, page(s), volume-issue number(s), publisher, city and/or country where published.

ESK	SCHULZRINNE, H., "RTP: A Transport Protocol for Real-Time Applications," IETF Internet Draft draft-ietf-avt-rtp-00.doc, Dec. 15, 1992, 23 pages.
	SCHULZRINNE, H. et al., "RTP: A Transport Protocol for Real-Time Applications," IETF Internet Draft draft-ietf-avt-rtp-01.txt, 05-6, 1993, 16 pages.
	SCHULZRINNE, H. et al., "RTP: A Transport Protocol for Real-Time Applications," IETF Internet Draft draft-ietf-avt-rtp-02.txt, Jul. 30, 1993, 24 pages.
	SCHULZRINNE, H. et al., "RTP: A Transport Protocol for Real-Time Applications," IETF Internet Draft draft-ietf-avt-rtp-04.txt, Oct. 20, 1993, 33 pages.
	SCHULZRINNE, H. et al., "RTP: A Transport Protocol for Real-Time Applications," Network Working Group Request for Comments Request for Comments: 1889, Jan. 1996, 61 pages.
	SINGHAL, S.K. et al., "Using a Position History-Based Protocol for Distributed Object Visualization," Stanford University Technical Report No. CS-TR-94-1505, 1994, 25 pages.
	"System for Establishing Communication Between Audiovisual Terminals Using Digital Channels Up To 2 Mbit/s," Amended/New Draft Recommendation Of The H.240-Series Submitted To The Xth CCITT Plenary Assembly COM XV-R 94-E, 05-1992, 68 pages.
	THOMAS, E., "Listserv Distribute Protocol," Network Working Group Request for Comments: 1429, Feb., 1993, 7 pages.
	TURLETTI, T., "H.261 software codec for videoconferencing over the Internet," Rapports de Recherche No. 1834, Jan. 1993, pp. 1-18.
	VIN, H.M. et al., "Multimedia Conferencing in the Etherphone Environment," Computer: Multimedia Information Systems, Oct. 1991, pp. 69-79.
	VONDERWEIDT, G. et al., "A Multipoint Communication Service for Interactive Applications," IEEE Transactions on Communications, vol. 39, No. 12, Dec. 1991, pp. 1875-1885.
	WAITZMAN, D. et al., "Distance Vector Multicast Routing Protocol," Network Working Group Request for Comments: 1075, Nov. 1988, 20 pages.
	WANCHO, F., Digest Message Format: Network Working Group Request for Comments: 1153, Apr. 1990, 4 pages.
	WATERS, A.G., "Multicast Provision for High Speed Networks," High Performance Networking, IV: Proc. Of the IFIP TC6/WG6.4 Fourth International Conference on High Performance Networking, Dec. 14-18, 1992, pp. 317-332.
	WEISS, G. et al., "Packet Switched Voice Conferencing Across Interconnected Networks," Proceedings 13.sup.th Conference on Local Computer Networks, Oct. 10-12, 1988, pp. 114-124.
	WEISS, G. et al., "A Comparative Analysis of Implementation Mechanism for Packet Voice Conferencing," IEEE INFOCOM '90 Proceedings vol. 1., 1990, pp. 1062-1070.
	WILLEBEEK-LEMAIR, M.H. et al., "Centralized versus Distributed Schemes for Videoconferencing," Proceedings of the Fifth IEEE Computer Society Workshop on Future Trends of Distributed Computing Systems, Aug. 28-30, 1995, pp. 85-93.
	ZARROS, P.N., et al., "Statistical Synchronization Among Participants in Real-Time Multimedia Conference," IEEE InfoCom Proceedings '94 vol. 1, 1994, pp. 912-919.
	ZIEGLER, C. et al., "Implementation Mechanisms for Packet Switched Voice Conferencing," IEEE Journal on Selected Areas in Communications, vol. 7, No. 5, Jun. 1989, pp. 698-706.
	ALTENHOFEN, Michael et al., "The BERKOM Multimedia Collaboration Service," ACM Multimedia, 1993, pp. 457-462.
	ARANGO, Mauricio et al., "Touring Machine: A Software Infrastructure to Support Multimedia Communications," Communications of the ACM, 1993, pp. 186-189.
	CHANG, Wan-the et al., "Call Processing And Signaling In A Desktop Multimedia Conferencing System," Proc. Of GLOBECOM, 1992, pp. 225-229.

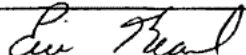
Examiner Signature		Date Considered	1 MAY 2011
--------------------	---	-----------------	------------

*EXAMINER: Initial if reference considered, whether or not citation is in conformance with M.P.E.P. § 609. Draw line through citation if not in conformance and not considered. Include copy of this form with next communication to Applicant.

SECOND
INFORMATION DISCLOSURE
STATEMENT BY APPLICANT

(use as many sheets as necessary)

Sheet 5 of 9

In re Reexamination of U.S. Patent No. / Control No.:	5,822,523 / 90/011,033
Issue Date:	October 13, 1998
First Named Inventor	Jeffrey J. Rothschild et al.
Confirmation/Group Art Unit No.	1686 / 3992
Attorney Docket No.	0078494-000001

NON-PATENT LITERATURE DOCUMENTS

Include name of the author (in CAPITAL LETTERS), title of the article (when appropriate), title of the item (book, magazine, journal, serial, symposium, catalog, etc.), date, page(s), volume-issue number(s), publisher, city and/or country where published.

ESK	DEERING, Stephen Edward, Multicast Routing In A Datagram Internetwork, Stanford University Dissertation, Dec. 1991, pp. i-xiii and 1-137.
	HORTON, Mark R., "UUCP Mail Interchange Format Standard," Networking Working Group Request for Comments: 976, Feb. 1986, 10 pages.
	KANTOR, Brian et al., "Network News Transfer Protocol: A Proposed Standard for the Stream-Based Transmission of News," Networking Working Group Request for Comments: 977, Feb. 1986, 22 pages.
	LEINER, B. (ed.), "Critical Issues in High Bandwidth Networking," Networking Working Group Request for Comments: 1077, Nov. 1988, 37 pages.
	NAGLE, John, "Congestion Control in IP/TCP Internetworks," Networking Group Request for Comments: 896, Jan. 6, 1984, 8 pages.
	ONG, Lyndon Y. and Schwartz, Mischa, "Centralized and Distributed Control for Multimedia Conferencing," Proceedings of ICC, 1993, pp. 197-201.
	ROMAHN, Gotz, "System Aspects Of Multipoint Videoconferencing," GLOBECOM, 1987, pp. 723-725.
	SCHULZRINNE et al., "RTP: A Transport Protocol for Real-Time Applications," IETF Internet Draft draft-ietf-avt-rtp-06.txt, Nov. 28, 1994, 93 pages.
	SCHULZRINNE et al., "RTP: A Transport Protocol for Real-Time Applications," IETF Internet Draft draft-ietf-avt-rtp-new-08.txt, Jul. 14, 2000, 90 pages.
	ZELLWEGER, Polle T. et al., "An Overview Of The Etherphone System And Its Applications," 2nd IEEE Conference on Computer Workstations, Mar. 7-10, 1988, pp. 160-168.
	Defendants' Initial Disclosure of Prior Art Under Civil Local Rule 16-7(D)-(E), 21 Pages, Entered Apr. 4, 2000 in HearMe v. Lipstream Networks, Inc. et al., United States District Court for the Northern District of California, Case No. C 99-04506 WHA.
	Defendants' Response Chart For U.S. application No. 5,822,523 Under Civil Local Rule 16-9(B), 26 Pages Plus Exhibits A-K, Dated Jul. 5, 2000, Filed In HearMe v. Lipstream Networks, Inc. et al., United States District Court for the Northern District of California--San Francisco Division, Case No. C 99-04506 WHA.
	Defendants' Response Chart For U.S. application No. 6,018,766 Under Civil Local Rule 16-9(B), 28 Pages Plus Exhibits A-J, Dated Aug. 1, 2000, Filed in HearMe v. Lipstream Networks, Inc. et al., United States District Court for the Northern District of California--San Francisco Division, Case No. C 99-04506 WHA.
	ADDEO, E.J. et al., "A Multi-Media Multi-Point Communication Services Capability for Broadband Networks," 1987, pp. 423-428.
	ADDEO, E.J. et al., "Personal Multi-Media Multi-Point Communication Services for Broadband Networks," 1988, pp. 53-57.
	AGUILAR, Lorenzo, "Datagram Routing for Internet Multicasting," 1984, pp. 58-63.
	AGUILAR, L. et al., "Architecture for a Multimedia Teleconferencing System," 1986, pp. 126-136.
	ARAS, C. et al., "Real-Time Communication in Packet-Switched Networks," 1994, pp. 122-139.
	BAGUETTE, Yves et al., "Comparison of TP4, TCP and XTP--Part 1: Connection Management Mechanisms (*)," vol. 3-N 5, Sep.-Oct. 1992, pp. 1-12.
	BAKER, Rusti et al., "Multimedia Processing Model for a Distributed Multimedia I/O System*," Network and Operating System Support for Digital Audio and Video, 1992, pp. 164-175.
	BETTATI, R. et al., "Connection Establishment for Multi-Party Real-Time Communication," Network and Operating Systems Support for Digital Audio and Video, 1995, pp. 240-250.
	BHARATH-KUMAR, Kadaba and et al., "Routing to Multiple Destinations in Computer Networks," 1993, pp. 343-351.

Examiner Signature	<i>E. J. Addeo for Robert</i>	Date Considered	1/29/2011
--------------------	-------------------------------	-----------------	-----------

*EXAMINER: Initial if reference considered, whether or not citation is in conformance with M.P.E.P. § 609. Draw line through citation if not in conformance and not considered. Include copy of this form with next communication to Applicant.

SECOND
INFORMATION DISCLOSURE
STATEMENT BY APPLICANT

(use as many sheets as necessary)

Sheet 6 of 9

In re Reexamination of U.S. Patent No. / Control No.:	5,822,523 / 90/011,033
Issue Date:	October 13, 1998
First Named Inventor	Jeffrey J. Rothschild et al.
Confirmation/Group Art Unit No.	1686 / 3992
Attorney Docket No.	0078494-000001

NON-PATENT LITERATURE DOCUMENTS

Include name of the author (in CAPITAL LETTERS), title of the article (when appropriate), title of the item (book, magazine, journal, serial, symposium, catalog, etc.), date, page(s), volume-issue number(s), publisher, city and/or country where published.

ESK	BIRCHLER, Barbara D. et al., "Toward a general Theory of Unicast-Based Multicast Communication*," pp. 237-251.
	BIRMAN, K.P. et al., "On Communication Support for Fault Tolerant Process Groups," Network Working Group Request for Comments: 992, Nov. 1986, pp. 1-16.
	BRADEN, Robert et al., "The Design of the RSVP Protocol," RSVP Project: Final Report, 05-27, 1993-Jun. 30, 1995, pp. 1-21.
	BROWN, E.F. et al., "A Continuous Presence Video Conferencing System," 1978, pp. 34.1.1-34.1.4.
	BROWN, T. et al., "Packet Video for Heterogeneous Networks Using CU-SEEME," Proceedings ICIP-96, Sep. 16-19, 1996, pp. 9-12.
	BUBENIK et al., "Multipoint Connection Management in High Speed Networks," 1991, pp. 59-68.
	CASNER, Stephen et al., "N-Way Conferencing with Packet Video," The Third International Workshop on Packet Video, Mar. 22-23, 1990, pp. 1-6.
	CHIA, L.T. et al., "An Experimental Integrated Workstation for Teleconferencing," Integrating Telecommunications and Information Technology on the Desktop, Mar. 1994, pp. 1-5.
	CLARK, David D. et al., "Supporting Real-Time Applications in an Integrated Services Packet Network: Architecture and Mechanism," 1992, pp. 14-26.
	CLARK, William J., "Multipoint Multimedia Conferencing," IEEE Communications Magazine, 05-1992, pp. 44-50.
	COHEN, David M. et al., "Performance Modeling of Video Teleconferencing in ATM Networks," IEEE Transactions on Circuits and Systems for Video Technology, vol. 3, No. 6, Dec. 1993, pp. 408-420.
	CROWCROFT, J. et al., "Multimedia Teleconferencing over International Packet Switched Networks. RN/90/XX," IEEE Conference on Communications Software: Communications for Distributed Applications & Systems, Apr. 18-19, 1991, pp. 23-33.
	DEERING, Stephen et al., "An Architecture for Wide-Area Multicast Routing," 1994, pp. 126-135.
	DEERING, Stephen E., "Multicast Routing in Internetworks and Extended LANs," SIGCOMM '88 Symposium Communications Architectures & Protocols, Aug. 16-19, 1988, pp. 55-64.
	DEERING, Stephen E. et al., "Multicast Routing in Datagram Internetworks and Extended LANs," ACM Transactions on Computer Systems, 05-1990, vol. 8, No. 2, pp. 85-110.
	DEWAN, Prasun et al., "A High-Level and Flexible Framework for Implementing Multiuser User Interfaces," ACM Transactions on Information Systems, Oct. 1992, vol. 10, No. 4, pp. 345-380.
	DRAOLI, M. et al., "Video Conferencing on a LAN/MAN Interconnected System: QoS Evaluation," Proceedings of the Fourth International Conference on Computer Communications and Networks, Sep. 20-23, 1995, pp. 170-177.
	DRAOLI, M. et al., "Videoconferencing on a LAN/MAN Architecture: Service Evaluation and System Dimensioning," Communications Technology Proceedings, 1996, vol. 2, pp. 630-633.
	ENSOR, J. Robert et al., "The Rapport Multimedia Conferencing System--A Software Overview," 2.sup.nd IEEE Conference on Computer Workstations, Mar. 7-10, 1988, pp. 52-58.
	FERRARI, Domenico et al., "Network support for multimedia A discussion of the Tenet Approach," Computer Networks and ISDN Systems, 1994, pp. 1267-1280.
	FLIESSER, R.J. et al., "Design of a Multicast ATM Packet Switch," 1993 Canadian Conference on Electrical and Computer Engineering, vol. 1, pp. 779-783.
	HAN, Jefferson et al., "CU-SeeMe VR Immersive Desktop Teleconferencing," ACM Multimedia, 1996, 9 pages.

Examiner Signature	<i>Eric Neal to Nalwa</i>	Date Considered	1 MAY 2011
--------------------	---------------------------	-----------------	------------

*EXAMINER: Initial if reference considered, whether or not citation is in conformance with M.P.E.P. § 609. Draw line through citation if not in conformance and not considered. Include copy of this form with next communication to Applicant.

**SECOND
INFORMATION DISCLOSURE
STATEMENT BY APPLICANT**

(use as many sheets as necessary)

Sheet 7 of 9

In re Reexamination of U.S. Patent No. / Control No.:	5,822,523 / 90/011,033
Issue Date:	October 13, 1998
First Named Inventor	Jeffrey J. Rothschild et al.
Confirmation/Group Art Unit No.	1686 / 3992
Attorney Docket No.	0078494-000001

NON-PATENT LITERATURE DOCUMENTS

Include name of the author (in CAPITAL LETTERS), title of the article (when appropriate), title of the item (book, magazine, journal, serial, symposium, catalog, etc.), date, page(s), volume-issue number(s), publisher, city and/or country where published.

ESK	HARJU, Jarmo et al., "Quality and Performance of a Desktop Video Conferencing System in the Network of Interconnected LANs," Proceedings of the 19th Conference on Local Networks, 1994, pp. 365-371.
	HEINRICHS, Bernd et al., "OSI Communication Services Supporting CSCW Applications," SIGDOC '93, 1993, pp. 107-115.
	HERZOG, Shai et al., "Sharing 'Cost' of Multicast Trees: An Axiomatic Analysis," ACM SIGCOMM '95 Conference, Aug. 1995, pp. 1-15.
	HOPPER, Andy, "Pandora--an experimental system for multimedia applications," Operating Systems Review, Apr. 1990, vol. 24, No. 2, pp. 19-34.
	HUANG, Jau-Hsiung et al., "Design and Implementation of Multimedia Conference System on Broadcast Networks," 18th Conference on Local Computer Networks, 1993, pp. 337-341.
	JIA, Weija, "Implementation of a Reliable Multicast Protocol," Software--Practices & Experiences, Jul. 1997, pp. 813-849.
	KOERNER, Eckhart, "Group Management for a Multimedia Collaboration Service," Presented at EUNICE '96 Summer School on Telecommunications Services, Sep. 23-27, 1996, pp. 1-11.
	KOHLERT, Doug et al., "Implementing a Graphical Multi-user Interface Toolkit," Software--Practice and Experience, Sep. 1993, vol. 23, No. 9, pp. 981-999.
	LARSEN, A.B. et al., "'Continuous Presence' Video Conferencing at 1.5-6Mb/sec," pp. 391-398.
	LAUWERS, J. Chris et al., "Collaboration Awareness in Support of Collaboration Transparency: Requirements for the Next of Shared Window Systems," CHI '90 Proceedings, Apr. 1990, pp. 303-311.
	LEUNG, Wu-hon F. et al., "A Software Architecture for Workstations Supporting Multimedia Conferencing in Packet Switching Networks," IEEE Journal on Selected Areas in Communications, Apr. 1990, vol. 8, No. 1, pp. 380-390.
	LI, L. et al., "Real-time Synchronization Control In Multimedia Distributed Systems," pp. 294-305.
	LI, S. et al., "VC collaborator: a mechanism for video conferencing support," Proceedings of SPIE, Oct. 1995, pp. 89-99.
	MATHY, L. et al., "The ACCOPI Multimedia Transport Service over ATM," Proceedings of 2ndCOST237 Workshop on Teleservices and Multimedia Communication, Nov. 20-22, 1995, pp. 159-175.
	MATHY, L. et al., "A Group Communication Framework," Broadband Islands '94: Connecting with the End-user, 1994, pp. 167-178.
	MATHY, L. et al., "Towards an Integrated Solution for Multimedia Communications," Rev. AIM, 1996, pp. 3-10.
	MATHY, L. and Bonaventure, O., "QoS Negotiation for Multicast Communications," Multimedia Transport and Teleservices Lecture Notes in Computer Science, 1994, pp. 199-218.
	MCCANNE, S. et al., "Joint Source/Channel Coding for Multicast Packet Video," Proceedings of the International Conference on Image Processing, Oct. 23-26, 1995, pp. 25-28.
	MITZEL, Danny J. et al., "An Architectural Comparison of ST-II and RSVP," 10 pages.
	MITZEL, Danny J. et al., "Asymptotic Resource Consumption in Multicast Reservation Styles," ACM SIGCOMM '94 Conference, Aug. 1994, pp. 1-8.
	MOY, J., "Multicast Extensions to OSPF," Network Working Group Request for Comments: 1584, Mar. 1994, 83 pages.
	NGUYEN, Mai-Huong et al., "MCMP: A Transport/Session Level Distributed Protocol for Desktop Conference Setup," Sep. 1996, vol. 14, No. 7, pp. 1404-1421.
	NICHOLS, Kathleen M., "Network Performance of Packet Video on a Local Area Network," IPCCC '92, Apr. 1-3, 1992, pp. 0659-0666.

Examiner Signature	<i>Eric Seal to Nalva</i>	Date Considered	1 MAY 2011
--------------------	---------------------------	-----------------	------------

*EXAMINER: Initial if reference considered, whether or not citation is in conformance with M.P.E.P. § 609. Draw line through citation if not in conformance and not considered. Include copy of this form with next communication to Applicant.

**SECOND
INFORMATION DISCLOSURE
STATEMENT BY APPLICANT**

(use as many sheets as necessary)

Sheet 8 of 9

In re Reexamination of U.S. Patent No. / Control No.:	5,822,523 / 90/011,033
Issue Date:	October 13, 1998
First Named Inventor	Jeffrey J. Rothschild et al.
Confirmation/Group Art Unit No.	1686 / 3992
Attorney Docket No.	0078494-000001

NON-PATENT LITERATURE DOCUMENTS

Include name of the author (in CAPITAL LETTERS), title of the article (when appropriate), title of the item (book, magazine, journal, serial, symposium, catalog, etc.), date, page(s), volume-issue number(s), publisher, city and/or country where published.

ESK	NICOLAOU, Cosmos, "An Architecture for Real-Time Multimedia Communications Systems," IEEE Journal on Selected Area Communications, Apr. 1990, vol. 8, No. 1, pp. 391-400.
	PARSA, M. et al., "Scalable Internet Multicast Routing," 4th International Conference on Computer Communications and Networks, Sep. 20-23, 1995, pp. 162-166.
	PARTRIDGE, C., "A Proposed Flow Specification," Network Working Group Request for Comments: 1363, Sep. 1992, 17 pages.
	PASQUALE, Joseph C. et al., "The Multimedia Multicast Channel," Internetworking Research and Experience, 1994, vol. 5, pp. 151-162.
	PASQUALE, Joseph C. et al., "The multimedia multicasting problem," Multimedia Systems, 1998, pp. 43-59.
	RANGAN, P. Venkat, "Communication Architectures and Algorithms for Media Mixing in Multimedia Conferences," IEEE/ACM Transactions on Networking, 1993, pp. 20-30.
	REIBMAN, Amy R. et al., "Traffic Descriptors for VBR Video Teleconferencing Over ATM Networks," IEEE/ACM Transactions on Networking, Jun. 1995, vol. 3, No. 3, pp. 329-339.
	ROBINSON, John et al., "A Multimedia Interactive Conferencing Application for Personal Workstations," IEEE Transactions on Communications, Nov. 1991, pp. 1698-1708.
	ROBINSON, John A., "Communications services architecture for CSCW," Computer Communications, 05-1994, vol. 17, No. 5, pp. 339-347.
	SABRI, Shaker et al., "Video Conferencing Systems," Proceedings of the IEEE, Apr. 1985, vol. 73, No. 4, pp. 671-688.
	SAKATA, Shiro, "Multimedia and Multi-party Desktop Conference System (MERMAID) as Groupware Platform," IEEE Region 10's Ninth Annual International Conference Proceedings, Aug. 1994, pp. 739-743.
	SASSE, M.-A. et al., "Workstation-based multimedia conferencing: Experiences from the MICE project," Integrating Telecommunication and Information Technology on the Desktop, 1994, pp. 1-6.
	SCHMANDT, Chris et al., "An Audio and Telephone Server for Multi-media Workstations," 2nd IEEE Conference on Computer Workstations, Mar. 7-10, 1988, pp. 150-159.
	SCHOOLER, Eve M. et al., Stephen L., "An Architecture for Multimedia Connection Management," Reprinted from the Proceedings IEEE 4th Comsoc International Workshop on Multimedia Communications, Apr. 1992, pp. 271-274.
	SCHOOLER, Eve M., "Case Study: Multimedia Conference Control in a Packet-Switched Teleconferencing System," Reprinted from the Journal of Internetworking: Research and Experience, Jun. 1993, vol. 4, No. 2, pp. 99-120.
	SCHOOLER, Eve M., A Distributed Architecture for Multimedia Conference Control, ISI Research Report No. ISI/RR-91-289, Nov. 1991, pp. 1-18.
	SCHOOLER, Eve M. et al., "Multimedia Conferencing: Has it come of age?" Reprinted from the Proceedings 24th Hawaii International Conference on Systems Sciences, Jan. 1991, vol. 3, pp. 707-716.
	SOMAN, Sadhna et al., "An Experimental study of Video Conferencing over the Internet," IEEE Globecom '94, 1994, pp. 720-724.
	STRIGINI, Lorenzo et al., "Multicast Services on High-Speed Interconnected LANs," High Speed Local Area Networks, 1987, pp. 173-176.
	TANIGAWA, Hiroya et al., Personal Multimedia-Multipoint Teleconference System, 1991, pp. 1127-1134.
	TASSIULAS, Leandros et al., "Dynamic Server Allocation to Parallel Queues with Randomly Varying Connectivity," IEEE Transactions on Information Theory, Mar. 1993, vol. 39, No. 2, pp. 466-478.
V	TILLMAN, Matthew A. et al., "SNA and OSI: Three Strategies for Interconnection," Communications of the ACM, Feb. 1990, vol. 33, No. 2, pp. 214-224.

Examiner Signature	<i>Eve M. Schooler</i>	Date Considered	1 MAY 2011
--------------------	------------------------	-----------------	------------

*EXAMINER: Initial if reference considered, whether or not citation is in conformance with M.P.E.P. § 609. Draw line through citation if not in conformance and not considered. Include copy of this form with next communication to Applicant.

Substitute for form 1449/PTO & 1449B/PTO <div style="text-align: center;">SECOND</div> <div style="text-align: center;">INFORMATION DISCLOSURE</div> <div style="text-align: center;">STATEMENT BY APPLICANT</div> <p style="text-align: center;">(use as many sheets as necessary)</p> <p>Sheet 9 of 9</p>	<i>Complete if Known</i>										
	<table border="1" style="width: 100%; border-collapse: collapse;"> <tr> <td style="width: 60%;">In re Reexamination of U.S. Patent No. / Control No.:</td> <td>5,822,523 / 90/011,033</td> </tr> <tr> <td>Issue Date:</td> <td>October 13, 1998</td> </tr> <tr> <td>First Named Inventor</td> <td>Jeffrey J. Rothschild et al.</td> </tr> <tr> <td>Confirmation/Group Art Unit No.</td> <td>1686 / 3992</td> </tr> <tr> <td>Attorney Docket No.</td> <td>0078494-000001</td> </tr> </table>	In re Reexamination of U.S. Patent No. / Control No.:	5,822,523 / 90/011,033	Issue Date:	October 13, 1998	First Named Inventor	Jeffrey J. Rothschild et al.	Confirmation/Group Art Unit No.	1686 / 3992	Attorney Docket No.	0078494-000001
In re Reexamination of U.S. Patent No. / Control No.:	5,822,523 / 90/011,033										
Issue Date:	October 13, 1998										
First Named Inventor	Jeffrey J. Rothschild et al.										
Confirmation/Group Art Unit No.	1686 / 3992										
Attorney Docket No.	0078494-000001										

NON-PATENT LITERATURE DOCUMENTS	
Include name of the author (in CAPITAL LETTERS), title of the article (when appropriate), title of the item (book, magazine, journal, serial, symposium, catalog, etc.), date, page(s), volume-issue number(s), publisher, city and/or country where published.	
ESK	TURLETTI, Thierry et al., "Videoconferencing on the Internet," IEEE/ACM Transactions on Networking, 1996, pp. 340-351.
	TOPOLCIC, C. (ed.), "Experimental Internet Stream Protocol, version 2 (ST-11)," Network Working Group Request for Comments: 1190, Oct. 1990, 127 pages.
	VENKATESH, D. et al., "Investigation of Web Server Access as a Basis for Designing Video-on-Demand Systems," Proceedings of the International Society for Optical Engineering, Oct. 23-24, 1995, vol. 2617, pp. 2-11.
	WATABE, K. et al., "A Distributed Multiparty Desktop Conferencing System and its Architecture," 1990, pp. 386-393.
	What is RTP? (visited Jan. 4, 2000) < http://raddist.rad.com/networks/1996/lphone/rtp.htm >, 5 pages.
	WILDE, Erik et al., "Transport-Independent Group and Session Management for Group Communications Platforms," ETT, Jul.-Aug. 1997, vol. 8, No. 4, pp. 409-421.
	WILLEBEEK-LEMAIR, M.H. et al., "Centralized versus Distributed Schemes for Videoconferencing," Proceedings of the Fifth IEEE Computer Society Workshop on Future Trends of Distributed Computing System, Aug. 28-30, 1995, pp. 85-93.
	WOODSIDE, Murray C. et al., "Alternative Software Architectures for Parallel Protocol Execution with Synchronous IPC," IEEE/ACM Transactions on Networking, Apr. 1993, vol. 1, No. 2, pp. 178-186.
	XYLOMENOS, George et al., "IP Multicast for Mobile Hosts," IEEE Communications Magazine, Jan. 1997, pp. 54-58.
	XYLOMENOS, George et al., "IP multicast group management for point-to-point local distribution," Computer Communications, 1998, pp. 1645-1654.
	YEUNG, K.H. et al., "Selective Broadcast Data Distribution Systems," Proceedings of the 15th International Conference on Distributed Computing Systems, 05-30-Jun. 2, 1995, pp. 317-324.
	YUM, Tak-Shing et al., "Video Bandwidth Allocation for Multimedia Teleconferences," IEEE Transactions on Communications, Feb./Mar./Apr. 1995, vol. 43, Nos. 2/3/4, pp. 457-465.
	ZARROS, Panagiotis N. et al., "Interparticipant Synchronization in Real-Time Multimedia Conferencing Using Feedback," IEEE/ACM Transactions on Networking, Apr. 1996, vol. 4, No. 2, pp. 173-180.
	ZARROS, Panagiotis N. et al., "Statistical Synchronization Among Participants in Real-Time Multimedia Conference," Proceedings of the IEEE Symposium on Computers and Communications, Jun. 27-29, 1995, pp. 30-36.
	ZHANG, Lixia et al., "RSVP: A New Resource ReSerVation Protocol," Accepted By IEEE Network Magazine, (date unknown), 22 pages.
	OIKARINEN, J. et al., "Internet Relay Chat Protocol," Networking Group Request for Comments: 1459, 05-1993, < http://www.tuug.org/sup.about.firc/text/rfc1459.txt >, 57 pages.

Examiner Signature <i>Eui Heed For Value</i>	Date Considered 1 MAY 2011
---	-------------------------------

*EXAMINER: Initial if reference considered, whether or not citation is in conformance with M.P.E.P. § 609. Draw line through citation if not in conformance and not considered. Include copy of this form with next communication to Applicant.

Search Notes 	Application/Control No. 90011033	Applicant(s)/Patent Under Reexamination 5,822,523
	Examiner <i>Nalven</i>	Art Unit 3992

SEARCHED			
Class	Subclass	Date	Examiner
395	200.170		

SEARCH NOTES		
Search Notes	Date	Examiner
Reviewed Patented File's Prosecution History	7/21/10	ain

INTERFERENCE SEARCH			
Class	Subclass	Date	Examiner

--	--

Issue Classification 	Application/Control No. 90011033	Applicant(s)/Patent Under Reexamination 5,822,523
	Examiner <i>Nalven</i>	Art Unit 3992

ORIGINAL					INTERNATIONAL CLASSIFICATION												
CLASS		SUBCLASS			CLAIMED					NON-CLAIMED							
709		236			G	0	6	F	15 / 16 (2006.01.01)								
CROSS REFERENCE(S)																	
CLASS	SUBCLASS (ONE SUBCLASS PER BLOCK)																
709	206	230															

<input type="checkbox"/> Claims renumbered in the same order as presented by applicant																<input type="checkbox"/> CPA		<input type="checkbox"/> T.D.		<input type="checkbox"/> R.1.47	
Final	Original	Final	Original	Final	Original	Final	Original	Final	Original	Final	Original	Final	Original	Final	Original						
1	1	15	17	31	33	47	49														
2	2	16	18	32	34																
3	3	17	19	33	35																
4	4	18	20	34	36																
5	5	19	21	35	37																
6	6	20	22	36	38																
	7	21	23	37	39																
	8	22	24	38	40																
7	9	23	25	39	41																
8	10	24	26	40	42																
9	11	25	27	41	43																
10	12	26	28	42	44																
11	13	27	29	43	45																
12	14	28	30	44	46																
13	15	29	31	45	47																
14	16	30	32	46	48																

_____ (Assistant Examiner)		Total Claims Allowed: 47	
(Date) 04/18/2011		(Date)	
/ANDREW L. NALVEN/ Primary Examiner, Art Unit 3992		O.G. Print Claim(s) 1	O.G. Print Figure 6
(Primary Examiner)		(Date)	

Reexamination 	Application/Control No. 90/011,033	Applicant(s)/Patent Under Reexamination 5,822,523
	Certificate Date	Certificate Number C1

Requester	Correspondence Address:	<input type="checkbox"/> Patent Owner	<input checked="" type="checkbox"/> Third Party
NOVAK DRUCE & QUIGG, LLP (NDQ REEXAMINATION GROUP) 1000 LOUISIANA STREET FIFTY-THIRD FLOOR HOUSTON, TX 77002			

LITIGATION REVIEW <input checked="" type="checkbox"/>	aln (examiner initials)	7/21/10 (date)
Case Name		Director Initials
Paltalk v Sony - 2:09CV274 - OPEN		<i>Lin 7/21/10</i> <i>RY</i>
2:06CV367 - CLOSED		↓
3:99CV4506 - CLOSED		

COPENDING OFFICE PROCEEDINGS	
TYPE OF PROCEEDING	NUMBER
1. none	
2.	
3.	
4.	



UNITED STATES PATENT AND TRADEMARK OFFICE

UNITED STATES DEPARTMENT OF COMMERCE
 United States Patent and Trademark Office
 Address: COMMISSIONER FOR PATENTS
 P.O. Box 1450
 Alexandria, Virginia 22313-1450
 www.uspto.gov

BIB DATA SHEET

CONFIRMATION NO. 1686

SERIAL NUMBER 90/011,033	FILING or 371(c) DATE 06/14/2010	CLASS 700	GROUP ART UNIT 3992	ATTORNEY DOCKET NO. 0078494-000001	
APPLICANTS 5,822,523, Residence Not Provided; PALTALK HOLDINGS, INC. (OWNER), NEW YORK, NY; NOVAK DRUCE & QUIGG LLP (3RD PTY. REQ.), HOUSTON, TX; NOVAK DRUCE & QUIGG, LLP, HOUSTON, TX					
** CONTINUING DATA ***** This application is a REX of 08/595,323 02/01/1996 PAT 5,822,523					
** FOREIGN APPLICATIONS *****					
** IF REQUIRED, FOREIGN FILING LICENSE GRANTED **					
Foreign Priority claimed <input type="checkbox"/> Yes <input checked="" type="checkbox"/> No 35 USC 119(a-d) conditions met <input type="checkbox"/> Yes <input checked="" type="checkbox"/> No Verified and Acknowledged <u>/ANDREW L. NALVEN/</u> Examiner's Signature	<input type="checkbox"/> Met after Allowance Initials	STATE OR COUNTRY	SHEETS DRAWINGS	TOTAL CLAIMS 6	INDEPENDENT CLAIMS 1
ADDRESS BUCHANAN, INGERSOLL & ROONEY PC POST OFFICE BOX 1404 ALEXANDRIA, VA 22313-1404 UNITED STATES					
TITLE SERVER-GROUP MESSAGING SYSTEM FOR INTERACTIVE APPLICATIONS					
FILING FEE RECEIVED 2520	FEES: Authority has been given in Paper No. _____ to charge/credit DEPOSIT ACCOUNT No. _____ for following:		<input type="checkbox"/> All Fees <input type="checkbox"/> 1.16 Fees (Filing) <input type="checkbox"/> 1.17 Fees (Processing Ext. of time) <input type="checkbox"/> 1.18 Fees (Issue) <input type="checkbox"/> Other _____ <input type="checkbox"/> Credit		



UNITED STATES PATENT AND TRADEMARK OFFICE

UNITED STATES DEPARTMENT OF COMMERCE
United States Patent and Trademark Office
Address: COMMISSIONER FOR PATENTS
P.O. Box 1450
Alexandria, Virginia 22313-1450
www.uspto.gov

APPLICATION NO.	FILING DATE	FIRST NAMED INVENTOR	ATTORNEY DOCKET NO.	CONFIRMATION NO.
90/011,033	06/14/2010	5,822,523	0078494-000001	1686

21839 7590 05/26/2011

BUCHANAN, INGERSOLL & ROONEY PC
POST OFFICE BOX 1404
ALEXANDRIA, VA 22313-1404

EXAMINER

ART UNIT PAPER NUMBER

DATE MAILED: 05/26/2011

Please find below and/or attached an Office communication concerning this application or proceeding.



UNITED STATES PATENT AND TRADEMARK OFFICE

Commissioner for Patents
United States Patents and Trademark Office
P.O.Box 1450
Alexandria, VA 22313-1450
www.uspto.gov

THIRD PARTY REQUESTER'S CORRESPONDENCE ADDRESS
NOVAK DRUCE & QUIGG, LLP
(NDQ REEXAMINATION GROUP)
1000 LOUISIANA STREET, FIFTY-THIRD FLOOR
HOUSTON, TX 77002

Date:

MAILED

MAY 26 2011

CENTRAL REEXAMINATION UNIT

EX PARTE REEXAMINATION COMMUNICATION TRANSMITTAL FORM

REEXAMINATION CONTROL NO. : 90011033
PATENT NO. : 5822523
ART UNIT : 3992

Enclosed is a copy of the latest communication from the United States Patent and Trademark Office in the above identified ex parte reexamination proceeding (37 CFR 1.550(f)).

Where this copy is supplied after the reply by requester, 37 CFR 1.535, or the time for filing a reply has passed, no submission on behalf of the ex parte reexamination requester will be acknowledged or considered (37 CFR 1.550(g)).



UNITED STATES DEPARTMENT OF COMMERCE

U.S. Patent and Trademark Office

Address: COMMISSIONER FOR PATENTS
P.O. Box 1450
Alexandria, Virginia 22313-1450

APPLICATION NO/ CONTROL NO.	FILING DATE	FIRST NAMED INVENTOR / PATENT IN REEXAMINATION	ATTORNEY DOCKET NO.
90/011,033	14 June 2010	5,822,523	0078494-000001

BUCHANAN, INGERSOLL & ROONEY PC
POST OFFICE BOX 1404
ALEXANDRIA, VA 22313-1404

EXAMINER

ERIC KEASEL

ART UNIT	PAPER
----------	-------

3992

20110525

DATE MAILED:

Please find below and/or attached an Office communication concerning this application or proceeding.

Commissioner for Patents

A review of the record reveals that an IDS filed April 18, 2011 has not yet been considered. Please find attached a copy of the initialed and signed IDS.

Eric Keasel
SPE
Art Unit: 3992

**FOURTH
INFORMATION DISCLOSURE
STATEMENT BY APPLICANT**

(use as many sheets as necessary)

In re Reexamination of U.S. Patent No. / Control No.:	5,822,523/90/011,033
Issue Date	October 13, 1998
First Named Inventor	Jeffrey J. Rothschild et al.
Confirmation/Group Art Unit No.	1686 / 3992
Attorney Docket No.	0078494-000001

Sheet 1 of 1

U.S. PATENT DOCUMENTS

Examiner Initials	Document Number- Kind Code	Publication Date MM-DD-YYYY	Name of Patentee or Applicant of Cited Document	Pages, Columns, Lines Where Relevant Passages or Figures Appear
	US-			
	US-			
	US-			
	US-			
	US-			
	US-			
	US-			
	US-			
	US-			
	US-			

FOREIGN PATENT DOCUMENTS

Examiner Initials	Foreign Patent Document Country Code ¹ , Number, Kind Code	Publication Date (MM-DD-YYYY)	Name of Patentee or Applicant of Cited Document	STATUS						
				Translation	Partial Translation	Eng. Lang. Summary	Search Report	IPER	Abstract	Cited in Spec. / Pg. No(s).

¹Enter Office that issued the document, by the two-letter code.

NON-PATENT LITERATURE DOCUMENTS

Examiner Initials	Include name of the author (in CAPITAL LETTERS), title of the article (when appropriate), title of the item (book, magazine, journal, serial, symposium, catalog, etc.), date, page(s), volume-issue number(s), publisher, city and/or country where published.
ESK	Memorandum Opinion and Order, Dated April 5, 2011, filed in Paltalk Holdings, Inc. v. Sony Computer Entertainment America, Inc., et al., United States District Court for the Eastern District of Texas-Marshall Division, Case No. 2:09-CV-274-DF-CE

Examiner Signature	<i>Eric Howard to Nelson</i>	Date Considered	25 MAY 2011
--------------------	------------------------------	-----------------	-------------

*EXAMINER: Initial if reference considered, whether or not citation is in conformance with M.P.E.P. § 609. Draw line through citation if not in conformance and not considered. Include copy of this form with next communication to Applicant.



US005822523C1

(12) EX PARTE REEXAMINATION CERTIFICATE (8495th)
United States Patent
Rothschild et al.

(10) Number: US 5,822,523 C1
(45) Certificate Issued: Aug. 30, 2011

(54) SERVER-GROUP MESSAGING SYSTEM FOR INTERACTIVE APPLICATIONS

(75) Inventors: Jeffrey J. Rothschild, Los Gatos, CA (US); Marc P. Kwiatkowski, Los Gatos, CA (US); Daniel J. Samuel, Sunnyvale, CA (US)

(73) Assignee: PalTalk Holdings, Inc., New York, NY (US)

Reexamination Request:

No. 90/011,033, Jun. 14, 2010

Reexamination Certificate for:

Patent No.: 5,822,523
Issued: Oct. 13, 1998
Appl. No.: 08/595,323
Filed: Feb. 1, 1996

(51) Int. Cl. G06F 15/16 (2006.01)

(52) U.S. Cl. 709/236; 709/206; 709/230

(58) Field of Classification Search 395/200, 395/170

See application file for complete search history.

(56) References Cited

U.S. PATENT DOCUMENTS

- 4,479,195 A 10/1984 Herr et al.
4,558,180 A 12/1985 Scordo
4,572,509 A 2/1986 Sitrick
4,740,954 A 4/1988 Cotton et al.
4,807,224 A 2/1989 Naron et al.
4,984,235 A 1/1991 Hillis et al.
4,991,171 A 2/1991 Teraslinna et al.
4,998,199 A 3/1991 Tashiro et al.
5,079,767 A 1/1992 Perlman
5,083,800 A 1/1992 Lockton

(Continued)

FOREIGN PATENT DOCUMENTS

EP 0 384 876 B1 8/1990
EP 0598969 A1 6/1994

(Continued)

OTHER PUBLICATIONS

Ahuja, S.R., et al., "The Rapport Multimedia Conferencing System," Conference on Office Information Systems 1988, pp. 1-7.

(Continued)

Primary Examiner—Andrew L Nalven

(57) ABSTRACT

A method for deploying interactive applications over a network containing host computers and group messaging servers is disclosed. The method operates in a conventional network architecture comprised of conventional network links and unicast gateways and routers. The hosts send messages containing destination group addresses by unicast to the group messaging servers. The group addresses select message groups maintained by the group messaging servers. For each message group, the group message servers also maintain a list of all the hosts that are members of the particular group. In its most simple implementation, the method consists of the group server receiving a message from a host containing a destination group address. Using the group address, the group messaging server then selects a message group which lists all of the host members of the group which are the targets of messages to the group. The group messaging server then forwards the message to each of the target hosts. In an interactive application, many messages will be arriving at the group server close to one another in time. Rather than simply forward each message to its targeted hosts, the group messaging server aggregates the contents of each of messages received during a specified time period and then sends an aggregated message to the targeted hosts. The time period can be defined in a number of ways. This method reduces the message traffic between hosts in a networked interactive application and contributes to reducing the latency in the communications between the hosts.

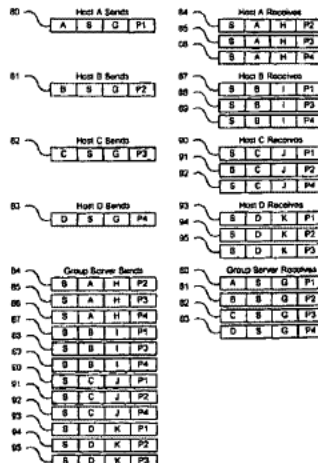

U.S. PATENT DOCUMENTS

5,089,813 A 2/1992 DeLuca et al.
5,117,420 A 5/1992 Hillis et al.
5,150,410 A 9/1992 Bertrand
5,150,464 A 9/1992 Sidhu et al.
5,245,608 A 9/1993 Deaton, Jr. et al.
5,247,615 A 9/1993 Mori et al.
5,257,113 A 10/1993 Chen et al.
5,260,942 A 11/1993 Auerbach et al.
5,287,530 A 2/1994 Davis et al.
5,289,460 A 2/1994 Drake, Jr. et al.
5,297,143 A 3/1994 Fridrich et al.
5,309,433 A 5/1994 Cidon et al.
5,309,437 A 5/1994 Perlman et al.
5,329,619 A 7/1994 Page et al.
5,361,256 A 11/1994 Doeringer et al.
5,365,523 A 11/1994 Derby et al.
5,408,261 A 4/1995 Kamata et al.
5,418,912 A 5/1995 Christenson
5,430,727 A 7/1995 Callon
5,436,896 A 7/1995 Anderson et al.
5,453,780 A 9/1995 Chen et al.
5,466,200 A 11/1995 Ulrich et al.
5,475,819 A 12/1995 Miller et al.
5,481,735 A 1/1996 Mortensen et al.
5,502,726 A 3/1996 Fischer
5,517,494 A 5/1996 Green
5,530,699 A 6/1996 Kline
5,539,741 A 7/1996 Barraclough et al.
5,558,339 A 9/1996 Perlman
5,581,552 A 12/1996 Civanlar et al.
5,586,257 A 12/1996 Perlman
5,586,937 A 12/1996 Menashe
5,590,281 A 12/1996 Stevens
5,594,732 A 1/1997 Bell et al.
5,598,535 A 1/1997 Brech et al.
5,608,726 A 3/1997 Virgile
5,630,757 A 5/1997 Gagin et al.
5,634,011 A 5/1997 Auerbach et al.
5,649,103 A 7/1997 Datta et al.
5,659,691 A 8/1997 Durward et al.
5,674,127 A 10/1997 Horstmann et al.
5,684,800 A 11/1997 Dobbins et al.
5,685,775 A 11/1997 Bakoglu et al.
5,690,582 A 11/1997 Ulrich et al.
5,729,540 A 3/1998 Wegrzyn
5,736,982 A 4/1998 Suzuki et al.
5,740,170 A 4/1998 Andou et al.
5,740,231 A 4/1998 Cohn et al.
5,761,436 A 6/1998 Nielsen
5,778,187 A 7/1998 Monteiro et al.
5,784,568 A 7/1998 Needham
5,785,630 A 7/1998 Bobick et al.
5,787,085 A 7/1998 Fox
5,805,823 A 9/1998 Seitz
5,805,830 A 9/1998 Reese et al.
5,812,552 A 9/1998 Arora et al.
5,829,041 A 10/1998 Okamoto et al.
5,841,980 A 11/1998 Waters et al.
5,890,995 A 4/1999 Bobick et al.
5,930,259 A 7/1999 Katsube et al.
5,946,308 A 8/1999 Dobbins et al.
5,956,485 A 9/1999 Perlman
6,041,166 A 3/2000 Hart et al.
6,076,117 A 6/2000 Billings
6,115,747 A 9/2000 Billings et al.
6,269,404 B1 7/2001 Hart et al.
6,304,550 B1 10/2001 Fox
6,426,954 B1 7/2002 Krause
6,873,627 B1 3/2005 Miller et al.
7,493,558 B2 2/2009 Leahy et al.

FOREIGN PATENT DOCUMENTS

EP 0 637 149 2/1995
EP 0687088 A2 12/1995
EP 0714684 A1 6/1996
JP 2-2262 1/1990
JP 2-192344 7/1990
JP 4-249938 9/1992
JP 5-199257 8/1993
JP 5-219096 8/1993
JP 5-336155 12/1993
JP 6-30041 2/1994
JP 6-152601 5/1994
JP 7-254900 10/1995
WO WO 93/15572 8/1993
WO WO 94/24803 10/1994
WO WO 95/10908 4/1995
WO WO 95/10911 4/1995
WO WO 97/04386 2/1997

OTHER PUBLICATIONS

Armstrong, S. et al., "Multicast Transport Protocol," Network Working Group Request For Comments: 1301, 1992, 31 pages.
Berglund, E.J. et al. "Amaze: A Distributed Multi-Player Game Program using the Distributed V Kernel," IEEE Proceedings of the Fourth Int'l Conf. on Distributed Systems, 1984, pp. 248-253.
Braden, R. (ed.), "Requirements for Internet Hosts—Communication Layers," Network Working Group Request for Comments: 1122, Oct. 1989, 100 pages.
Braden, R. (ed.), "Requirements for Internet Hosts—Application and Support," Network Working Group Request for Comments: 1123, Oct. 1989, 84 pages.
Braden, R. et al., "Integrated Services in the Internet Architecture: An Overview," Network Working Group Request for Comments: 1633, Jun. 1994, 27 pages.
Braudes, R. et al., "Requirements for Multicast Protocols," Network Working Group Request for Comments: 1458, May 1993, 16 pages.
Cameron, P. et al., "Transport Multiplexing Protocol (TMux)," Network Working Group Request for Comments: 1692, Aug. 1994, 10 pages.
Cheriton, D.R. et al., "Host Groups: A Multicast Extension for Datagram Internetworks," ACM/IEEE Proceedings of the Ninth Data Communications Symposium, Sep. 10-13, 1985, pp. 172-179.
Chimiak, W., "A Comment on Packet Video Remote Conferencing and the Transport/Network Layers," Network Working Group Request for Comments: 1453, Apr. 1993, 9 pages.
Crocker, D.H., "Standard For The Format Of ARPA Internet Text Messages," IETF RFC #822, Apr. 13, 1982, 43 pages.
Deering, S.E. et al., "Host Groups: A Multicast Extension to the Internet Protocol," Network Working Group Request for Comments: 966, Dec. 1985, 23 pages.
Deering, S., "Host Extensions for IP Multicasting," Network Working Group for Comments: 1054, May 1988, 16 pages.
Deering, S., "Host Extensions for IP Multicasting," Network Working Group Request for Comments: 1112, Aug. 1989, 14 pages.
Handley, M.J., "The Car System: Multimedia in Support of Collaborative Design," Computing and Control Division Colloquium on 'Multimedia and Professional Applications', Feb. 3, 1993, pp. 8/1-8/5.

- Henckel, L., "Multipeer Transport Services for Multimedia Applications," High Performance Networking, V: Proc. Of the IFIP TC6/WG6.4 Fifth International Conference on High Performance Networking, Jun. 27-Jul. 1, 1994, pp. 167-184.
- Kirsche, T. et al., "Communication support for cooperative work," Computer Communications, vol. 16, No. 9, Sep. 1993, pp. 594-602.
- Lauwers, J.C. et al., "Replicated Architectures for Shared Window Systems: A Critique," Proc. of the ACM Conference on Office Information Systems, 1990, pp. 249-260.
- Leung, Y-W. et al., "Optimum Connection Paths for a Class of Videoconferences," Int'l Conference on Comm. ICC 91, vol. 1 of 3, Jun. 23-26, 1991, pp. 0859-0865.
- Leung, Y-W. et al., "A Modular Multirate Video Distributing System-Design and Dimensioning," IEEE/ACM Transactions on Networking, vol. 2, No. 6, Dec. 1994, pp. 549-557.
- Li, Y. et al., "Multipoint Conferencing for Mobile Communications Network," 2.sup.nd Int'l. Conference on Universal Personal Communications, Oct. 12-15, 1993, pp. 212-216.
- Multipoint Control Units For Audiovisual Systems Using Digital Channels Up To 2 Mbit/s, ITU Standard Draft H.231, 1993, pp. 11-22.
- Ngoh, L., "Multicast Support for Group Communications," Computer Networks and ISDN Systems, 166-178, Oct. 1991, pp. 166-178.
- Postel, J.B., "Simple Mail Transfer Protocol," Internet Engineering Task Force (IETF) Request for Comments (RFC) 821, Aug. 1982, 59 pages.
- Rajagopalan, B., "Membership protocols for distributed conference control," Computer Communications, vol. 18, No. 10, Oct. 1995, pp. 695-708.
- Ramanathan, S. et al., "Optimal Communication Architecture for Multimedia Conferencing in Distributed Systems," The 12.sup.th Int'l Conference on Distributed Computing Systems, Jun. 9-12, 1992, pp. 46-53.
- Rose, M.T. et al., "Proposed Standard for Message Encapsulation," Network Working Group Request for Comments: 934, Jan. 1985, 9 pages.
- Schaffer, U., "MPPS—A Multiparty Presentation Service," Upper Layer Protocols, Architectures and Applications: Proc. Of the IFIP TC6/WG6.5 International Conference on Upper Layer Protocols, Architectures and Applications, Jun. 1-3, 1994, pp. 243-256.
- Schooler, E.M., "The Impact of Scaling on a Multimedia Connection Architecture," ACM Journal of Multimedia Systems, vol. 1, No. 1, 1993, pp. 1-10.
- Schulzrinne, H., "RTP: A Transport Protocol for Real-Time Applications," IETF Internet Draft draft-ietf-avt-rtp-00.doc, Dec. 15, 1992, 23 pages.
- Schulzrinne, H. et al., "RTP: A Transport Protocol for Real-Time Applications," IETF Internet Draft draft-ietf-avt-rtp-01.txt, 05-6, 1993, 16 pages.
- Schulzrinne, H. et al., "RTP: A Transport Protocol for Real-Time Applications," IETF Internet Draft draft-ietf-avt-rtp-02.txt, Jun. 30, 1993, 24 pages.
- Schulzrinne, H. et al., "RTP: A Transport Protocol for Real-Time Applications," IETF Internet Draft draft-ietf-avt-rtp-04.txt, Oct. 20, 1993, 33 pages.
- Schulzrinne, H. et al., "RTP: A Transport Protocol for Real-Time Applications," Network Working Group Request for Comments Request for Comments: 1889, Jan. 1996, 61 pages.
- Singhal, S.K. et al., "Using a Position History-Based Protocol for Distributed Object Visualization," Stanford University Technical Report No. CS-TR-94-1505, 1994, 25 pages.
- "System for Establishing Communication Between Audiovisual Terminals Using Digital Channels Up To 2 Mbit/s," Amended/New Draft Recommendation Of The H.240-Series Submitted To The Xth CCITT Plenary Assembly COM XV-R 94-E, May 1992, 68 pages.
- Thomas, E., "Listserv Distribute Protocol," Network Working Group Request for Comments: 1429, Feb. 1993, 7 pages.
- Turletti, T., "H.261 software codec for videoconferencing over the Internet," Rapports de Recherche No. 1834, Jan. 1993, pp. 1-18.
- Vin, H.M. et al., "Multimedia Conferencing in the Telephone Environment," Computer: Multimedia Information Systems, Oct. 1991, pp. 69-79.
- Vonderweidt, G. et al., "A Multipoint Communication Service for Interactive Applications," IEEE Transactions on Communications, vol. 39, No. 12, Dec. 1991, pp. 1875-1885.
- Waitzman, D. et al., "Distance Vector Multicast Routing Protocol," Network Working Group Request for Comments: 1075, Nov. 1988, 20 pages.
- Wancho, F., Digest Message Format: Network Working Group Request for Comments: 1153, Apr. 1990, 4 pages.
- Waters, A.G., "Multicast Provision for High Speed Networks," High Performance Networking, IV: Proc. Of the IFIP TC6/WG6.4 Fourth International Conference on High Performance Networking, Dec. 14-18, 1992, pp. 317-332.
- Weiss, G. et al., "Packet Switched Voice Conferencing Across Interconnected Networks," Proceedings 13.sup.th Conference on Local Computer Networks, Oct. 10-12, 1988, pp. 114-124.
- Weiss, G. et al., "A Comparative Analysis of Implementation Mechanism for Packet Voice Conferencing," IEEE INFOCOM '90 Proceedings vol. 1., 1990, pp. 1062-1070.
- Willebeck-Lemair, M.H. et al., "Centralized versus Distributed Schemes for Videoconferencing," Proceedings of the Fifth IEEE Computer Society Workshop on Future Trends of Distributed Computing Systems, Aug. 28-30, 1995, pp. 85-93.
- Zarros, P.N. et al., "Statistical Synchronization Among Participants in Real-Time Multimedia Conference," IEEE InfoCom Proceedings '94 vol. 1, 1994, p. 912-919.
- Ziegler, C. et al., "Implementation Mechanisms for Packet Switched Voice Conferencing," IEEE Journal on Selected Areas in Communications, vol. 7, No. 5, Jun. 1989, pp. 698-706.
- Altenhofen, Michael et al., "The Berkomp Multimedia Collaboration Service," ACM Multimedia, 1993, pp. 457-462.
- Arango, Mauricio et al., "Touring Machine: A Software Infrastructure to Support Multimedia Communications," Communications of the ACM, 1993, pp. 186-189.
- Chang, Wan-the et al., "Call Processing And Signaling in A Desktop Multimedia Conferencing System," Proc. Of Globecom, 1992, pp. 225-229.
- Deering, Stephen Edward, Multicast Routing In A Datagram Internetwork, Stanford University Dissertation, Dec. 1991, pp. i-xiii and 1-137.
- Horton, Mark R., "UUCP Mail Interchange Format Standard," Networking Working Group Request for Comments: 976, Feb. 1986, 10 pages.

- Kantor, Brian et al., "Network News Transfer Protocol: A Proposed Standard for the Stream-Based Transmission of News," Networking Working Group Request for Comments: 977, Feb. 1986, 22 pages.
- Leiner, B. (ed.), "Critical Issues in High Bandwidth Networking," Networking Working Group Request for Comments: 1077, Nov. 1988, 37 pages.
- Nagle, John, "Congestion Control in IP/TCP Internetworks," Networking Group Request for Comments: 896, Jan. 6, 1984, 8 pages.
- Ong, Lyndon Y. and Schwartz, Mischa, "Centralized and Distributed Control for Multimedia Conferencing," Proceedings of ICC, 1993, pp. 197-201.
- Romahn, Gotz, "System Aspects Of Multipoint Videoconferencing," Glovecom, 1987, pp. 723-725.
- Schulzrinne et al., "RTP: A Transport Protocol for Real-Time Applications," IETF Internet Draft draft-ietf-avt-rtp-06.txt, Nov. 28, 1994, 93 pages.
- Schulzrinne et al., "RTP: A Transport Protocol for Real-Time Applications," IETF Internet Draft draft-ietf-avt-rtp-new-08.txt, Jul. 14, 2000, 90 pages.
- Zellweger, Polle T. et al., "An Overview Of The Etherphone System And Its Applications," 2nd IEEE Conference on Computer Workstations, Mar. 7-10, 1988, pp. 160-168.
- Defendants' Initial Disclosure of Prior Art Under Civil Local Rule 16-7(D)-(E), 21 Pages, Entered Apr. 4, 2000 in *HearMe v. Lipstream Networks, Inc. et al.*, United States District Court for the Northern District of California, Case No. C 99-04506 WHA.
- Defendants' Response Chart For U.S. application No. 5,822,523 Under Civil Local Rule 16-9(B), 26 Pages Plus Exhibits A-K, Dated Jul. 5, 2000, Filed in *HearMe v. Lipstream Networks, Inc. et al.*, United States District Court for the Northern District of California—San Francisco Division, Case No. C 99-04506 WHA.
- Defendants' Response Chart For U.S. application No. 6,018,766 Under Civil Local Rule 16-9(B), 28 Pages Plus Exhibits A-J, Dated Aug. 1, 2000, Filed in *HearMe v. Lipstream Networks, Inc. et al.*, United States District Court for the Northern District of California—San Francisco Division, Case No. C 99-04506 WHA.
- Addeo, E.J. et al., "A Multi-Media Multi-Point Communication Services Capability for Broadband Networks," 1987, pp. 423-428.
- Addeo, E.J. et al., "Personal Multi-Media Multi-Point Communication Services for Broadband Networks," 1988, pp. 53-57.
- Aguilar, Lorenzo, "Datagram Routing for Internet Multicasting," 1984, pp. 58-63.
- Aguilar, L. et al., "Architecture for a Multimedia Teleconferencing System," 1986, pp. 126-136.
- Aras, C. et al., "Real-Time Communication in Packet-Switched Networks," 1994, pp. 122-139.
- Baguette, Yves et al., "Comparison of TP4, TCP and XTP—Part 1: Connection Management Mechanisms (*)," vol. 3—N 5, Sep.—Oct. 1992, pp. 1-12.
- Baker, Rusti et al., "Multimedia Processing Model for a Distributed Multimedia I/O System*," Network and Operating System Support for Digital Audio and Video, 1992, pp. 164-175.
- Bettati, R. et al., "Connection Establishment for Multi-Party Real-Time Communication," Network and Operating Systems Support for Digital Audio and Video, 1995, pp. 240-250.
- Bharath-Kumar, Kadaba and et al., "Routing to Multiple Destinations in Computer Networks," 1993, pp. 343-351.
- Birchler, Barbara D. et al., "Toward a general Theory of Unicast-Based Multicast Communication*," pp. 237-251.
- Birman, K.P. et al., "On Communication Support for Fault Tolerant Process Groups," Network Working Group Request for Comments: 992, Nov. 1986, pp. 1-16.
- Braden, Robert et al., "The Design of the RSVP Protocol," RSVP Project: Final Report, 05-27, Jun. 30, 1993, 1995, pp. 1-21.
- Brown, E.F. et al., "A Continuous Presence Video Conferencing System," 1978, pp. 34.1.1-34.1.4.
- Brown, T. et al., "Packet Video for Heterogeneous Networks Using CU-SEEME," Proceedings ICIP-96, Sep. 16-19, 1996, pp. 9-12.
- Bubenik et al., "Multipoint Connection Management in High Speed Networks," 1991, pp. 59-68.
- Casner, Stephen et al., "N-Way Conferencing with Packet Video," The Third International Workshop on Packet Video, Mar. 22-23, 1990, pp. 1-6.
- Chia, L.T. et al., "An Experimental Integrated Workstation for Teleconferencing," Integrating Telecommunications and Information Technology on the Desktop, Mar. 1994, pp. 1-5.
- Clark, David D. et al., "Supporting Real-Time Applications in an Integrated Services Packet Network: Architecture and Mechanism," 1992, pp. 14-26.
- Clark, William J., "Multipoint Multimedia Conferencing," IEEE Communications Magazine, May 1992, pp. 44-50.
- Cohen, David M. et al., "Performance Modeling of Video Teleconferencing in ATM Networks," IEEE Transactions on Circuits and Systems for Video Technology, vol. 3, No. 6, Dec. 1993, pp. 408-420.
- Crowcroft, J. et al., "Multimedia Teleconferencing over International Packet Switched Networks. RN/90/XX," IEEE Conference on Communications Software: Communications for Distributed Applications & Systems, Apr. 18-19, 1991, pp. 23-33.
- Deering, Stephen et al., "An Architecture for Wide-Area Multicast Routing," 1994, pp. 126-135.
- Deering, Stephen E., "Multicast Routing in Internetworks and Extended LANs," SIGCOMM '88 Symposium Communications Architectures & Protocols, Aug. 16-19, 1988, pp. 55-64.
- Deering, Stephen E, et al., "Multicast Routing in Datagram Internetworks and Extended LANs," ACM Transactions on Computers Systems, May 1990, vol. 8, No. 2, pp. 85-110.
- Dewan, Prasun et al., "A High-Level and Flexible Framework for Implementing Multiuser User Interfaces," ACM Transactions on Information Systems, Oct. 1992, vol. 10, No. 4, pp. 345-380.
- Draoli, M. et al., "Video Conferencing on a LAN/MAN Interconnected System: QoS Evaluation," Proceedings of the Fourth International Conference on Computer Communications and Networks, Sep. 20-23, 1995, pp. 170-177.
- Draoli, M. et al., "Videoconferencing on a LAN/MAN Architecture: Service Evaluation and System Dimensioning," Communications Technology Proceedings, 1996, vol. 2, pp. 630-633.
- Ensor, J. Robert et al., "The Rapport Multimedia Conferencing System—A Software Overview," 2.sup.nd IEEE Conference on Computer Workstations, Mar. 7-10, 1988, pp. 52-58.

- Ferrari, Domenico et al., "Network support for multimedia A discussion of the Tenet Approach," *Computer Networks and ISDN Systems*, 1994, pp. 1267-1280.
- Fliesser, R.J. et al., "Design of a Multicast ATM Packet Switch," 1993 Canadian Conference on Electrical and Computer Engineering, vol. 1, pp. 779-783.
- Han, Jefferson et al., "CU-SeeMe VR Immersive Desktop Teleconferencing," *ACM Multimedia*, 1996, 9 pages.
- Harju, Jarmo et al., "Quality and Performance of a Desktop Video Conferencing System in the Network of Interconnected LANs," *Proceedings of the 19th Conference on Local Networks*, 1994, pp. 365-371.
- Heinrichs, Bernd et al., "OSI Communication Services Supporting CSCW Applications," *SIGDOC '93*, 1993, pp. 107-115.
- Herzog, Shai et al., "Sharing 'Cost' of Multicast Trees: An Axiomatic Analysis," *ACM SIGCOMM '95 Conference*, Aug. 1995, pp. 1-15.
- Hopper, Andy, "Pandora—an experimental system for multimedia applications," *Operating Systems Review*, Apr. 1990, vol. 24, No. 2, pp. 19-34.
- Huang, Jau-Hsiung et al., "Design and Implementation of Multimedia Conference System on Broadcast Networks*," 18th Conference on Local Computer Networks, 1993, pp. 337-341.
- Jia, Weija, "Implementation of a Reliable Multicast Protocol," *Software—Practices & Experiences*, Jul. 1997, pp. 813-849.
- Koerner, Eckhart, "Group Management for a Multimedia Collaboration Service," Presented at EUNICE '96 Summer School on Telecommunications Services, Sep. 23-27, 1996, pp. 1-11.
- Kohlert, Doug et al., "Implementing a Graphical Multi-user Interface Toolkit," *Software—Practice and Experience*, Sep. 1993, vol. 23, No. 9, pp. 981-999.
- Larsen, A.B. et al., "'Continuous Presence' Video Conferencing at 1.5-6Mb/sec," pp. 391-398.
- Lauwers, J. Chris et al., "Collaboration Awareness in Support of Collaboration Transparency: Requirements for the Next of Shared Window Systems," *CHI '90 Proceedings*, Apr. 1990, pp. 303-311.
- Leung, Wu-hon F. et al., "A Software Architecture for Workstations Supporting Multimedia Conferencing in Packet Switching Networks," *IEEE Journal on Selected Areas in Communications*, Apr. 1990, vol. 8, No. 1, pp. 380-390.
- Li, L. et al., "Real-time Synchronization Control in Multimedia Distributed Systems" pp. 294-305.
- Li, S. et al., "VC collaborator: a mechanism for video conferencing support*," *Proceedings of SPIE*, Oct. 1995, pp. 89-99.
- Mathy, L. et al., "The ACCOPI Multimedia Transport Service over ATM," *Proceedings of 2ndCOST237 Workshop on Teleservices and Multimedia Communication*, Nov. 20-22, 1995, pp. 159-175.
- Mathy, L. et al., "A Group Communication Framework," *Broadband Islands '94: Connecting with the End-user*, 1994, pp. 167-178.
- Mathy, L. et al., "Towards an Integrated Solution for Multimedia Communications," *Rev. AIM*, 1996, pp. 3-10.
- Mathy, L. and Bonaventure, O., "QoS Negotiation for Multicast Communications," *Multimedia Transport and Teleservices Lecture Notes in Computer Science*, 1994, pp. 199-218.
- McCanne, S. et al., "Joint Source/Channel Coding for Multicast Packet Video," *Proceedings of the International Conference on Image Processing*, Oct. 23-26, 1995, pp. 25-28.
- Mitzel, Danny J. et al., "An Architecture Comparison of ST-II and RSVP," 10 pages.
- Mitzel, Danny J. et al., "Asymptotic Resource Consumption in Multicast Reservation Styles," *ACM SIGCOMM '94 Conference*, Aug. 1994, pp. 1-8.
- Moy, J., "Multicast Extensions to OSPF," *Network Working Group Request for Comments: 1584*, Mar. 1994, 83 pages.
- Nguyen, Mai-Huong et al., "MCMP: A Transport/Session Level Distributed Protocol for Desktop Conference Setup," Sep. 1996, vol. 14, No. 7, pp. 1404-1421.
- Nichols, Kathleen M., "Network Performance of Packet Video on a Local Area Network," *IPCCC '92*, Apr. 1-3, 1992, pp. 0659-0666.
- Nicolaou, Cosmos, "An Architecture for Real-Time Multimedia Communications Systems," *IEEE Journal on Selected Area Communications*, Apr. 1990, vol. 8, No. 1, pp. 391-400.
- Parsa, M. et al., "Scalable Internet Multicast Routing," 4th International Conference on Computer Communications and Networks, Sep. 20-23, 1995, pp. 162-166.
- Partridge, C., "A Proposed Flow Specification," *Network Working Group Request for Comments: 1363*, Sep. 1992, 17 pages.
- Pasquale, Joseph C. et al., "The Multimedia Multicast Channel," *Internetworking Research and Experience*, 1994, vol. 5, pp. 151-162.
- Pasquale, Joseph C. et al., "The multimedia multicasting problem," *Multimedia Systems*, 1998, pp. 43-59.
- Rangan, P. Venkat, "Communication Architectures and Algorithms for Media Mixing in Multimedia Conferences," *IEEE/ACM Transactions on Networking*, 1993, pp. 20-30.
- Reibman, Amy R. et al., "Traffic Descriptors for VBR Video Teleconferencing Over ATM Networks," *IEEE/ACM Transactions on Networking*, Jun. 1995, vol. 3, No. 3, pp. 329-339.
- Robinson, John et al., "A Multimedia Interactive Conferencing Application for Personal Workstations," *IEEE Transactions on Communications*, Nov. 1991, pp. 1698-1708.
- Robinson, John A., "Communications services architecture for CSCW," *Computer Communications*, May 1994, vol. 17, No. 5, pp. 339-347.
- Sabri, Shaker et al., "Video Conferencing Systems," *Proceedings of the IEEE*, Apr. 1985, vol. 73, No. 4, pp. 671-688.
- Sakata, Shiro, "Multimedia and Multi-party Desktop Conference System (MERMAID) as Groupware Platform," *IEEE Region 10's Ninth Annual International Conference Proceedings*, Aug. 1994, pp. 739-743.
- Sasse, M.-A. et al., "Workstation-based multimedia conferencing: Experiences from the MICE project," *Integrating Telecommunication and Information Technology on the Desktop*, 1994, pp. 1-6.
- Schmandt, Chris et al., "An Audio and Telephone Server for Multi-media Workstations," *2nd IEEE Conference on Computer Workstations*, Mar. 7-10, 1988, pp. 150-159.
- Schooler, Eve M. et al., Stephen L., "An Architecture for Multimedia Connection Management," Reprinted from the *Proceedings IEEE 4th Comsoc International Workshop on Multimedia Communications*, Apr. 1992, pp. 271-274.

- Schooler, Eve M., "Case Study: Multimedia Conference Control in a Packet-Switched Teleconferencing System," Reprinted from the Journal of Internetworking: Research and Experience, Jun. 1993, vol. 4, No. 2, pp. 99-120.
- Schooler, Eve M., "An Distributed Architecture for Multimedia Conference Control," ISI Research Report No. ISI/RR-91-289, Nov. 1991, pp. 1-18.
- Schooler, Eve M. et al., "Multimedia Conferencing: Has it come of age?" Reprinted from the Proceedings 24th Hawaii International Conference on Systems Sciences, Jan. 1991, vol. 3, pp. 707-716.
- Soman, Sadhna et al., "An Experimental study of Video Conferencing over the Internet," IEEE Globecom '94, 1994, pp. 720-724.
- Strigini, Lorenzo et al., "Multicast Services on High-Speed Interconnected LANs," High Speed Local Area Networks, 1987, pp. 173-176.
- Tanigawa, Hiroya et al., "Personal Multimedia-Multipoint Teleconference System, 1991, pp. 1127-1134.
- Tassioulas, Leandros et al., "Dynamic Server Allocation to Parallel Queues with Randomly Varying Connectivity," IEEE Transactions on Information Theory, Mar. 1993, vol. 39, No. 2, pp. 466-478.
- Tillman, Matthew A. et al., "SNA and OSI: Three Strategies for Interconnection," Communications of the ACM, Feb. 1990, vol. 33, No. 2, pp. 214-224.
- Turletti, Thierry et al., "Videoconferencing on the Internet," IEEE/ACM Transactions on Networking, 1996, pp. 340-351.
- Topolcic, C. (ed.), "Experimental Internet Stream Protocol, version 2 (ST-11)," Network Working Group Request for Comments: 1190, Oct. 1990, 127 pages.
- Venkatesh, D. et al., "Investigation of Web Server Access as a Basis for Designing Video-on-Demand Systems," Proceedings of the International Society for Optical Engineering, Oct. 23-24, 1995, vol. 2617, pp. 2-11.
- Watabe, K. et al., "A Distributed Multiparty Desktop Conferencing System and its Architecture," 1990, pp. 386-393.
- What Is RTP? (visited Jan. 4, 2000) <<http://raddist.rad.com/networks/1996/iphone/rtp.htm>>, 5 pages.
- Wilde, Erik et al., "Transport-Independent Group and Session Management for Group Communications Platforms," ETT, Jul.-Aug. 1997, vol. 8, No. 4, pp. 409-421.
- Woodside, Murray C. et al., "Alternative Software Architectures for Parallel Protocol Execution with Synchronous IPC," IEEE/ACM Transactions on Networking, Apr. 1993, vol. 1, No. 2, pp. 178-186.
- Xylomenos, George et al., "IP Multicast for Mobile Hosts," IEEE Communications Magazine, Jan. 1997, pp. 54-58.
- Xylomenos, George et al., "IP Multicast group management for point-to-point local distribution," Computer Communications, 1998, pp. 1645-1654.
- Yeung, K.H. et al., "Selective Broadcast Data Distribution Systems," Proceedings of the 15th International Conference on Distributed Computing Systems 05-30-Jun. 2, 1995, pp. 317-324.
- Yum, Tak-Shing et al., "Video Bandwidth Allocation for Multimedia Teleconferences," IEEE Transactions on Communications, Feb./Mar./Apr. 1995, vol. 43, Nos. 2/3/4, pp. 457-465.
- Zarros, Panagiotis N. et al., "Interparticipant Synchronization in Real-Time Multimedia Conferencing Using Feedback," IEEE/ACM Transactions on Networking, Apr. 1996, vol. 4, No. 4, pp. 173-180.
- Zarros, Panagiotis N. et al., "Statistical Synchronization Among Participants in Real-Time Multimedia Conference," Proceedings of the IEEE Symposium on Computers and Communications, Jun. 27-29, 1995, pp. 30-36.
- Zhang, Lixia et al., "RSVP: A New Resource Reservation Protocol," Accepted By IEEE Network Magazine, (date unknown), 22 pages.
- Oikarinen, J. et al., "Internet Relay Chat Protocol," Networking Group Request for Comments: 1459, May 1993, <<http://www.tuug.org/sup..about.firc/text/rfc1459.txt>>, 57 pages.
- Macedonia, Michael R. et al., "A Taxonomy for Networked Virtual Environments," Immersive Telepresence, pp. 48-56.
- Funkhouser, Thomas A., "Ring: A Client-Server System for Multi-User Virtual Environments," 1995 Symposium on Interactive 3D Graphics, pp. 85-209, Monterey, CA.
- Van Hook, Daniel J. et al., "An Approach to DIS Scalability," 11th DIS Workshop, pp. 1-9, Sep. 26-30, 1994.
- Oikarinen, J. et al., "Internet Relay Chat Protocol," Network Working Group, May 1993, pp. 1-61.
- IEEE Standard for Information Technology—Protocols for Distributed Interactive Simulation Applications, IEEE, Nov. 10, 2009, pp. 1-64.
- Abdel-Wahab, Hussein, "Reliable Information Service for Internet Computer Conferencing," IEEE, 1993, pp. 128-142.
- Amir, Yair, "Replication Using Group Communication Over a Partitioned Network," Thesis, 1995, pp. 1-95.
- Bangay, Shaun, "Parallel Implementation of a Virtual Reality System on a Transputer Architecture," Jul. 1993, pp. 1-128.
- Brutzman, Donald P., "A Virtual World for an Autonomous Underwater Vehicle," Dissertation, Dec. 1994, pp. 1-293.
- Brutzman, Donald P. et al., "Internetwork Infrastructure Requirements for Virtual Environments," Naval Postgraduate School, pp. 1-11.
- Calvin, James O. et al., "Stow Realtime Information Transfer and Networking System Architecture," Twelfth Workshop on Standards for the Interoperability of Distributed Simulations, Mar. 13-17, 1995, pp. 1-11.
- Cheriton, David R. et al., "Distributed Process Groups in the V Kernel," ACM Transactions on Computer Systems, vol. 3, No. 2, May 1985, pp. 77-107.
- Curtis, Pavel et al., "MUDs Grow Up: Social Virtual Reality in the Real World," Xerox PARC, Jan. 19, 1993, pp. 1-6.
- Sanders, Robert M. et al., The Xpress Transfer Protocol (XTP) A Tutorial (Expanded Version), NASA Johnson Space Center, Engineering directorate, Flight Data Systems Division, University of Houston—Clear Lake, Jan. 1990, pp. 1-78.
- Duvvur, Prasanth, "Managing Data on the World Wide Web" State of the Art Survey of Innovative Tools and Techniques, Massachusetts Institute of Technology, Sep. 1995, pp. 1-102.
- Ellis, Clarence A., "A Model and Algorithm for Concurrent Access Within Groupware," University of Colorado at Boulder, Department of Computer Science, Apr. 1992, pp. 0-34.
- Evard, Remy, "Collaborative Networked Communication: MUDs as Systems Tools," Northeastern University, Monterey, California, Nov. 1-5, 1993, pp. 1-8.
- Friedman, Roy et al., "Packing Message as a Tool for Boosting the Performance of Total Ordering Protocols," Cornell University, Jul. 7, 1995, pp. 0-17.

- Gajewska, Hania et al., "Argo: A System for Distributed Collaboration", Digital Equipment Corporation, pp. 1-8.
- Gaudet, Stuart S., "Dynamic Project Collaboration and Control Using the World Wide Web", Massachusetts Institute of Technology, Oct. 1995, pp. 1-225.
- Golding, Richard Andrew, "Weak-consistency group communication and membership", Dissertation, Dec. 1992, pp. 1-165.
- Greenhalgh, Chris et al., "Massive: a Distributed Virtual Reality System Incorporating Spatial Trading", IEEE, 1995, pp. 27-34.
- Hofmann, Markus, "A Generic Concept for Large-Scale Multicast", Proceedings of International Zurich Seminar on Digital Communications, Zurich, Switzerland, Springer Verlag, Feb. 1996, pp. 1-12.
- Jabi, Wassim M. et al., "Beyond the Shared Whiteboard: Issues in Computer Supported Collaborative Design", Proceedings of CAAD Future '95: The Sixth International Conference on Computer-Aided Architectural Design Futures, Sep. 24-26, 1995, Singapore, pp. 1-9.
- Kaashoek, M.F., "Group Communication in Distributed Computer Systems", Vrije Universiteit, Amsterdam, The Netherlands, 1992, pp. 1-220.
- Kaashoek, M. Frans, "Efficient Reliable Group Communication for Distributed Systems", Vrije Universiteit, Amsterdam, The Netherlands, 1992, pp. 1-51.
- Macedonia, Michael R., "A Network Software Architecture for Large Scale Virtual Environments", Dissertation, Jun. 1995, pp. 1-200.
- Macedonia, Michael R. et al., "Exploiting Reality with Multicast Groups: A Network Architecture for Large-Scale Virtual Environments", Naval Postgraduate School, IEEE, 1995, pp. 2-10.
- Miller, Duncan C. Miller, Sc.D., "Network Performance Requirements for Real-Time Distributed Simulation", Proc. INET, 1994, pp. 241-241-8.
- Pullen, J. Mark, "Networking for Distributed Virtual Simulation", Proc. INET, 1994, pp. 243.1-243.7.
- Sdigh, Gurminder, "BrickNet: A Software Toolkit for Network-Based Virtual Worlds", The Massachusetts Institute of Technology, Presence, vol. 3, No. 1, Winter 1994, pp. 19-35.
- Srinivas, Kankanahalli et al., "MONET: A Multi-media System for Conferencing and Application Sharing in Distributed Systems", CERC Technical Report Series, Research Note, Concurrent Engineering Research Center, West Virginia University, Feb. 1992, pp. 1-19.
- Kaashoek, M. Frans et al., "Group communication in Amoeba and its applications", The British Computer Society, The Instituting of Electrical Engineers and IOP Publishing Ltd., 1993, pp. 48-58.
- Van Renesse, Robert et al., "Design and Performance of Horus: A Lightweight Group Communications System", Department of Computer Science, Cornell University, pp. 1-18.
- Van Renesse, Robert et al., "Reliable Multicast Between Microkernels", Computer Science Department, Cornell University, USENIX Association, Apr. 27-28, 1992, pp. 267-283.
- Feiner, Steven et al., "A Virtual World for Network Management", 1993 IEEE, Oct. 18-22, 1993, Seattle, WA, pp. 55-61.
- Crabtree, R.P., "Job networking", IBM Systems J, vol. 17, No. 3, 1978, pp. 206-220.
- Nagle, John, "Congestion Control in IP/TCP Internetworks", Computer Communication Review, ACM SIGCOMM, pp. 1-9.
- Nagle, John, "Congestion Control in IP/TCP Internetworks", Network Working Group, Request for Comments: 896, Jan. 6, 1984, pp. 1-9.
- Bartle, Dr. Richard, "Interactive Multi-User Computer Games", British Telecom plc., Dec. 1990, pp. 1-152.
- Eppinger, Jeffrey L. et al., "Camelot and Avalon, A Distributed Transaction Facility", pp. 1-43.
- Gettys, Jin et al., "Volum One: Xlib Programming Manual for Version 11 of the X Window System", O'Reilly & Associates, Inc., 1992, pp. 1-513.
- Bacon, David F. et al., "Compiler Transformations for High-Performance Computing", Computer Science Division, University of California, Berkeley, CA, pp. 1-79.
- Kazman, Rick, "Making Waves: On the Design of Architectures for Low-end Distributed Virtual Environments", Department of Computer Science, University of Waterloo, 1993 IEEE, pp. 442-449.
- Shaw, Chris et al., "The MR Toolkit Peers Package and Experiment", Department of Computing Science, University of Alberta, Jul. 14, 1994, IEEE, pp. 1-8.
- Tierman, T.R., "Synthetic Theater of War—Europe (STOW-E) Final Report", Naval Command, Control and Ocean Surveillance Center, Technical Report 1700, Jan. 1995, San Diego, CA, pp. 1-77.
- Hiranandani, Seema et al., "Evaluating Compiler Optimizations for Fortran D", Research Report, pp. 1-40.
- André, Françoise et al., "The Pandore Compiler: Overview and Experimental Results", IRISA, Publication No. 869, Oct. 1994, pp. 1-26.
- Banerjee, Prithviraj et al., "The Paradigm Compiler for Distributed-Memory Message Passing Multicomputers", First International Workshop on Parallel Processing, Bangalore, India, Dec. 1994, pp. 1-9.
- Wang, Qunjie et al., "EM—An Environment Manager for Building Networked Virtual Environments", 1995 IEEE, pp. 11-18.
- Singh, Gurminder et al., "BrickNet: Sharing Object Behaviors on the Net", Institute of Systems Science, 1995 IEEE, pp. 19-25.
- Broll, Wolfgang, "Interacting in Distributed Collaborative Virtual Environments", Institute for Applied Information Technology, German National Research Center for Computer Science (GMD), 1995 IEEE, pp. 148-155.
- Maxfield, John et al., "A Distributed Virtual Environment for Concurrent Engineering", The Keyworth Institute of Manufacturing and Information Systems Engineering, Virtual Working Environments Laboratory, School of Computer Studies, The University of Leeds, United Kingdom, 1995 IEEE, pp. 162-170.
- Zyda, Michael J., "Networked Virtual Environments", Computer Science Department, Naval Postgraduate School, 1995 IEEE, pp. 230-231.
- Wen, Chih-Po, "Portable Library Support for Irregular Applications", Dissertation, University of California at Berkeley, 1995, pp. 1-134.
- Yelick, Katherine et al., "Parallel Data Structure for Symbolic Computation", University of Berkeley, Computer Science Division, Parallel Symbolic Languages and Systems, Oct. 1995, pp. 1-17.

- Wen, Chih-Po et al., "Portable Runtime Support for Asynchronous Simulation", Computer Science Division, University of California, International Conference on Parallel Processing, 1995, pp. 1-10.
- Itsuki, Noda, "Soccer Server: a simulator of RoboCup", pp. 1-6.
- Wang, Qunjie, "Networked Virtual Reality", Thesis, University of Alberta, pp. 1-108.
- Macedonia, Michael R. et al., "NPSNET: A Multi-Player 3D Virtual Environment over the Internet", 1995 Symposium on Interactive 3D Graphics, Monterey, CA, pp. 93, 94 and 210.
- Vin, Harrick M. et al., "Hierarchical Conferencing Architectures for Inter-Group Multimedia Collaboration", Multimedia Laboratory, Department of Computer Science and Engineering, University of California at San Diego, pp. 43-54, 1991 ACM.
- Keune, C. M. et al., "Synthetic Theater of War-Europe (STOW-E) Technical Analysis", Technical Report 1703, Aug. 1995, pp. 1-75.
- Rangan, P. Venkat et al., "Communication Architectures and Algorithms for Media Mixing in Multimedia Conferences", IEEE/ACM Transactions on Networking, vol. 1., No. 1, Feb. 1993, pp. 20-30.
- Gong, Fengmin, "Multipoint Audio and Video Control for Packet-Based Multimedia Conference", MCNC Information Technologies, 1994 ACM, pp. 425-432.
- Kostrivas, John, "Design and Implementation of a Membership Server and Its Application Interface", Thesis, U.S. Navy, Naval Postgraduate School, Monterey, CA, Mar. 10, 1995, pp. 1-74.
- Shaw, V. et al., "A Distributed Multimedia System for Application and Communications", School of Applied Science, Nanyang Technological University, Singapore, 1995 IEEE, pp. 221-229.
- Herdman, Roger C., "Distributed Interactive Simulation of Combat", U.S. Government Printing Office, Sep. 1995, pp. 1-83.
- Ziegler, Chaim et al., "Multimedia Conferencing on Local Area Networks", Brooklyn College, 1990 IEEE, pp. 52-61.
- Singh, Gurminder et al., "Networked Virtual Worlds", Institute of Science Science, National University of Singapore, 1995 IEEE, pp. 44-49.
- Choudhary, Alok N. et al., "Proceedings of the 1993 International Conference on Parallel Processing", The Pennsylvania State University, vol. 11 Software, Aug. 16-20, 1993, CRC Press, Inc., pp. 1-33.
- Maloni, Kelly et al., Net games, Your Guide to the Games People Play on the Electronic Highway, Random House, pp. 1-6.
- Shah, Rawn et al., "Playing Wargames on the Internet", Complete guide to Empire, Galactic, and Netrek, pp. 1-30.
- Abdel-Wahab, H.M., "Multiuser tools architecture for group collaboration in computer networks", Department of Computer Science, Old Dominion University, VA, vol. 13, No. 3 Apr. 1990, pp. 165-169.
- Waters, Gill et al., "Three-party talk facility on a computer network", Department of Electronic Systems Engineering, University of Essex, UK, vol. 10, No. 3, Jun. 1987, pp. 115-120.
- Hodel, Horst, "Multicast-Routing-Grundlage des Multimedia-Conferencing im Internet", Bulletin SEV/VSE, 17/96, pp. 17-22, 3 and 65.
- Blanchard, Chuck et al., "What's Net in Reality Built for Two", Proceedings of the ACM Snowbird Conference, Feb. 1990, pp. 1-6.
- McFadden, Andy, "UDP client, the wave of the future", E-mail, <http://www.cs.cmu.edu/afs/cs.cmu.edu/.../udp>, Mar. 8, 1992, pp. 1-18.
- Flinn, Kelton et al., "Super VGA Air Warrior", Flight Manual, pp. 1-147.
- Snowswell, Michael, Overview of Cyberterm, a Cyberspace Protocol Implementation, pp. 1-12.
- Benedikt, Michael, Cyberspace: First Steps, MIT Press, London, England, pp. 1-35.
- Bennett, J. et al., "Munin: Distributed Shared Memory Based on Type-Specific Memory Coherence", Proceedings of 2nd ACM SIGPLAN Symposium on PPOPP, 1990, pp. 168-176.
- Carter, J. et al., "Implementation and Performance of Munin", Proceedings of 13th Symposium on Operating System Principles, 1991, pp. 152-164.
- Coleman, S. et al., "The TCP/IP Internet DOOM FAQ", <http://www.gamers.org/dhs/helpdocs/inetdoom.html>, Aug. 1998, pp. 1-10.
- Cotton, J. et al., "The TCP/IP Internet Gamer's FAQ", <http://x8.dejanews.com/getdoc.xp?AN=1031>, Jul. 1998, pp. 1-9.
- Coulouris, G. et al., "Distributed Systems: Concepts and Design", Addison-Wesley Publishing Co., 1994, pp. 333-348.
- Funkhouser, T., "Ring: A Client-Server System for Multi-User Virtual Environments", pp. 1-9.
- James, R. et al., "Creating Your Own Multiplayer Game Systems", Dr. Dobb's Information Highway Sourcebook, Winter, 1994, pp. 56-64.
- Macedonia, M., et al., "MBone Provides Audio and Video Across the Internet", IEEE Computer, vol. 27, Issue 4, 30-36, Apr. 1994, pp. 1-12.
- Macedonia, M., et al., "NPSNET: A Network Software Architecture for Large Scale Virtual Environments", Presence, vol. 3, No. 4, Fall, 1994, pp. 1-30.
- Schulzrinne, H. et al., "A Transport Protocol for Real-Time Applications", IFET Internet Draft draft-ifet-avt-rtt-05.txt, 1994, pp. 1-16.
- Wolfe, D., "The BBS Construction Kit", 1st Ed., 1994, John Wiley & Sons, Inc., New York, pp. 1-37.
- Server2.5p14.tar.gz ("Server Code") and BRMH-1.7.tar.gz ("Client Code") (source code dated no later than Aug. 1994) ("Netrek").
- J. Oikarinen et al. RFC 1459, "Internet Relay Chat Protocol", published May 1993 ("IRC RFC").
- R. Friedman et al. "Packing Messages as a Tool for Boosting the Performance of Total Ordering Protocols", Dept. of Science of Cornell University, published Jul. 7, 1995 ("Friedman").
- Daniel J. Van Hook, James O. Calvin, Michael K. Newton, and David A. Fusco, "An Approach to DIS Scalability," 11th DIS Workshop, Sep. 26-30, 1994 ("Van Hook").
- IEEE 1278-1993 "IEEE Standard for Information Technology-Protocols for Distributed Interactive Simulation Applications", approved Mar. 18, 1993, and published in 1993 ("DIS").
- T. A. Funkhouser, "Ring: A Client-Server System for Multi-User Virtual Environments," Association of Computing Machinery, 1995 Symposium on Interactive 3D Graphics, Monterey CA, Apr. 9-12, 1995 ("Ring").

Andy McFadden, "The History of Netrek", published Jan. 1, 1994 ("McFadden").

Michael R. Macedonia, "Exploiting Reality with Multicast Groups", published Sep. 1995 ("Macedonia").

Memorandum Opinion and Order, Dated Apr. 5, 2011, filed in *Paltalk Holdings, Inc. v. Sony Computer Entertainment America, Inc., et al.*, United States District Court for the Eastern District of Texas-Marshall Division, Case No. 2:09-CV-274-DF-CE.

1
EX PARTE
REEXAMINATION CERTIFICATE
ISSUED UNDER 35 U.S.C. 307

THE PATENT IS HEREBY AMENDED AS
INDICATED BELOW.

Matter enclosed in heavy brackets [] appeared in the patent, but has been deleted and is no longer a part of the patent; matter printed in italics indicates additions made to the patent.

AS A RESULT OF REEXAMINATION, IT HAS BEEN DETERMINED THAT:

The patentability of claims 1-6 is confirmed.

New claims 7-47 are added and determined to be patentable.

7. *The method of claim 1, wherein said time interval is between 33 ms and 200 ms.*

8. *The method of claim 1, wherein said aggregating is performed 5 to 30 times a second.*

9. *The method of claim 1, wherein said server implements a group messaging protocol layered on top of a transport protocol of said unicast network, wherein said group messaging protocol uses an address space that is separate from an address space of said transport protocol.*

10. *The method of claim 11, wherein said messaging protocol is performed at a session layer.*

11. *The method of claim 1, further comprising the step of performing, by said server, echo suppression.*

12. *The method of claim 1, wherein said plurality of host computers belonging to said first message group correspond to players that are in close proximity to one another within a three-dimensional space of a computer game.*

13. *The method of claim 1, further comprising the step of changing membership of said first message group based on activities of players within a computer game.*

14. *The method of claim 1, further comprising the step of changing membership of said first message group based on changes in player position within a three-dimensional space of a computer game.*

15. *The method of claim 1, wherein membership of said first message group changes dynamically over time.*

16. *The method of claim 1, wherein membership of said first message group changes over time based on control messages received from ones of said plurality of host computers.*

17. *The method of claim 1, wherein membership of said first message group changes over time based on indications received from ones of said plurality of host computers to join or leave said first message group.*

18. *The method of claim 1, wherein said messages comprise application specific state information.*

19. *The method of claim 1, wherein said unicast network is a wide area network.*

20. *The method of claim 19, wherein said group messaging server facilitates host computer-to-host computer communication.*

21. *The method of claim 19, wherein said group messaging server facilitates host computer-to-host computer communication usable by said plurality of host computers to maintain a consistent operating state.*

22. *The method of claim 19, wherein said group messaging server facilitates transmission of messages between ones of said plurality of host computers, wherein said transmitted messages are usable by said plurality of host computers to maintain a consistent operating state of an application.*

2

23. *The method of claim 22, wherein said application is a game.*

24. *The method of claim 19, wherein each message of said messages comprises information that other host computers in said first message group use to maintain a consistent application state.*

25. *The method of claim 19, wherein said messages are generated for transmission to host computers in said first message group.*

26. *The method of claim 19, wherein said messages are sent between said plurality of host computers in said first message group via said group messaging server.*

27. *The method of claim 1, wherein said aggregated message corresponds to a networked computer game, and wherein said first message group is only for players on a specified team within said game.*

28. *The method of claim 1, wherein said aggregated message corresponds to a networked computer game, and wherein said aggregated message is only for players on a specified team that are within a certain area of said game.*

29. *The method of claim 1, wherein said server is configured to receive a further message specifying said first message group and a second message group, and wherein said server is configured to transmit said further message to those of said plurality of host computers belonging to both said first and second message groups.*

30. *The method of claim 1, wherein said server is configured to receive a further message specifying a set of message groups and operations to be performed on said specified set of message groups to determine host computers to which said further message is to be delivered.*

31. *The method of claim 1, wherein said sending and said transmitting is implemented using a protocol that encapsulates message information within a datagram of a transport protocol of said unicast network.*

32. *The method of claim 1, wherein said sending and said transmitting are performed by an upper-level protocol implemented above a transport layer protocol of said unicast network, wherein said transport layer protocol is TCP/IP.*

33. *The method of claim 1, wherein said sending and said transmitting are performed by an upper-protocol implemented above a transport layer protocol of said unicast network, wherein said plurality of host computers are unable to send upper-level protocol messages to one another except through said group messaging server.*

34. *The method of claim 1, further comprising the steps of:*

said server receiving, from one of said plurality of host computers, a control message to create said first message group; and
creating said first message group in response to receiving said control message.

35. *The method of claim 1, further comprising the steps of:*

said server receiving, from a first host computer of said plurality of host computers, a control message to join said first message group; and
adding said first host computer to said first message group in response to receiving said request.

36. *The method of claim 1, further comprising the steps of:*

said server receiving, from a first host computer of said plurality of host computers, a control message to leave said first message group; and
removing said first host computer from said first message group in response to receiving said request.

3

37. The method of claim 1, further comprising the steps of:
said server receiving a control message to close said first message group; and
removing said first message group in response to receiving said request. 5
38. The method of claim 1, further comprising the steps of:
said server receiving, from a first host computer of said plurality of host computers, a control message to query message groups of said server; and 10
providing said list of message groups to said first host computer in response to said receiving said control message.
39. The method of claim 1, further comprising the steps of: 15
said server receiving, from a first computer of said plurality of host computers, a control message to query members of said first message group; and
providing a list of members of said first message group to said first host computer in response to receiving said control message. 20
40. The method of claim 1, further comprising the steps of: 25
said server receiving, from a first host computer of said plurality of host computers, a control message to query attributes of said first message group; and
providing attributes of said first message group to said first host computer in response to receiving control message.

4

41. The method of claim 1, further comprising the steps of:
said server receiving, from a first host computer of said plurality of host computers, a control message to connect to said group messaging server; and
storing information regarding said first host computer in response to receiving said control message.
42. The method of claim 1, further comprising the steps of:
said server receiving, from a first host computer of said plurality of host computers, a control message to disconnect from said group messaging server; and
removing information regarding said first host computer in response to receiving said control message.
43. The method of claim 1, wherein said aggregated message comprises compressing said aggregated payload.
44. The method of claim 1, wherein said time period is dynamically varied according to the predefined criterion.
45. The method of claim 44, wherein said predefined criterion is based on message rates received by said server.
46. The method of claim 44, wherein said predefined criterion is based on data rates received by said server.
47. The method of claim 1, further comprising of:
processing said payload portions according to an application specific processing function to replace data elements in said payload portions with processed results.

* * * * *