

UNITED STATES PATENT AND TRADEMARK OFFICE

BEFORE THE PATENT TRIAL AND APPEAL BOARD

ZTE (USA) INC., LG ELECTRONICS, INC., LG ELECTRONICS U.S.A. INC.,
LG ELECTRONICS MOBILECOMM U.S.A. INC.,
LG ELECTRONICS MOBILE RESEARCH U.S.A. LLC, and
LG ELECTRONICS ALABAMA, INC.

Petitioner

v.

Fundamental Innovation Systems International LLC

Patent Owner

Case IPR2018-00111¹
Patent 8,624,550

DECLARATION OF MR. STEVEN ROGERS

¹ LG Electronics, Inc., LG Electronics U.S.A. Inc., LG Electronics Mobilecomm U.S.A. Inc., LG Electronics Mobile Research U.S.A. LLC, and LG Electronics Alabama, Inc. were joined as parties to this proceeding via a Motion for Joinder in IPR2018-00461.

TABLE OF CONTENTS

	<u>Page</u>
I. Current Supplied on the VBUS Pin of the Power Supply System	4
II. Communication between Base Unit and Accessories	15
III. Enumeration and Current Supply before Configuration	19

1. My name is Steven Rogers. I am the sole inventor on U.S. Pat. No. 6,556,564 ("Rogers"), which I understand was raised as a prior art reference against U.S. Pat. No. 8,624,550 (the "550 patent").

2. I have experience with the creation of numerous networking, security telephony, and interface products, in a number of areas. I have founded and was CEO of several technology-based companies. These include Cryptek, Inc. (secure terminals), Objective Communications, Inc. (video switching), Cetacean Networks, Inc. (advanced routers) and Rivulet Communications, Inc. (real-time video networks).

3. I currently serve as the CEO of Centripetal Networks, Inc., which is developing the first strategic technology solution for cyber security. I previously provided analysis and development services for Unisys, American Satellite Corporation, Harris Government Systems, and COMSAT. I earlier served in the USAF, where I worked on new secure communications systems including the AWACS, National Military Command Center, various space-based systems, and Air Force One.

4. I received a Bachelor of Science degree in Electrical Engineering from Virginia Tech in 1974 and have been involved in interface and network device designs since then. I have also taken graduate-level classes from Virginia Tech in mathematical communications theory, and also in advanced computation. In addition I completed a course in advanced calculus from the

University of California in Santa Barbara. I have over 10 US Patents and my current company has many more patents. I invented the Rogers system while I was at Cetacean Networks, Inc., one of the multiple technology-based companies that I founded. It employed more than 130 employees and created network-processor-based 4th generation routers and network equipment. As a part of that project we had a team of engineers dedicated to IP phone development. This team was successful in creating phones that used Power over Ethernet. They also had USB interfaces (the first devices used USB 1.1).

5. Over my career, my work has involved various interface and network device designs. As a result, I am familiar with many types of network and component interfaces, including the USB interface. In fact, I have been familiar with the USB Specifications, Revisions 2.0 and 1.1, since at least September 1998. Additionally, because of my work and my interaction with other engineers and scientists, I am familiar with the general knowledge that a person with a bachelor's degree in electrical engineering plus 3-5 years of experience in circuit or device design (or equivalents thereof) might possess in the 2000-2002 time frame. In my discussion below, I will refer to such a person as a skilled artisan. Furthermore, with respect to knowledge concerning the technical areas in the '550 patent, the general knowledge possessed by a skilled artisan would also be possessed by a person with a master's degree in electrical engineering, or potentially in computer science, or a related field,

plus 2-3 years of experience with Universal Serial Bus (“USB”) in the 2000-2002 time frame. This is true because the latter would have even specialized knowledge related to the USB technology.

6. I have been asked by Fundamental Innovation Systems International LLC (“Fundamental”) to provide factual background regarding the inventions described in the Rogers patent.

I. Current Supplied on the VBUS Pin of the Power Supply System

7. The LAN telephone’s power supply system depicted in Figures 6 and 7(a) of the Rogers patent was designed to increase the maximum output voltage but comply with the USB specification’s current supply limits. In particular, the LAN telephone would output either 48V or 5V DC power on the VBUS pin (Pin 1) of the USB connector as depicted in Figure 7(a).

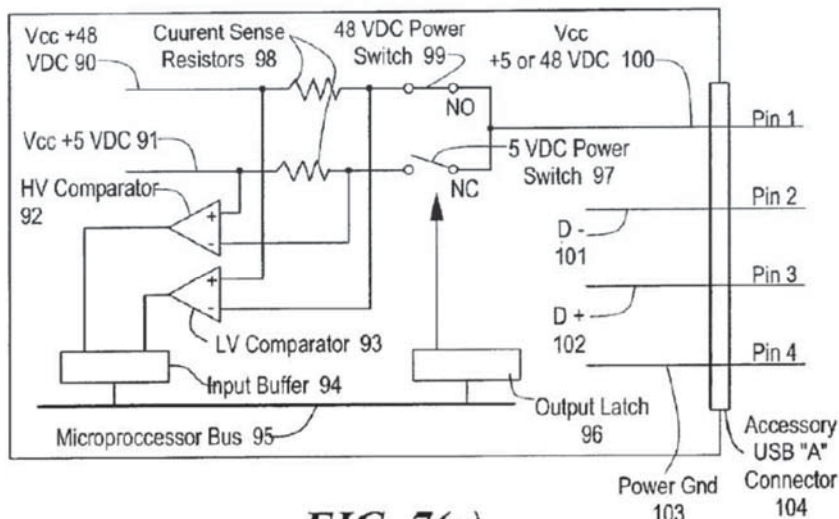

FIG. 7(a)

8. The current on the VBUS pin, however, would need to comply

with the current limit for cables and connectors specified in the USB

Explore Litigation Insights

Docket Alarm provides insights to develop a more informed litigation strategy and the peace of mind of knowing you're on top of things.

Real-Time Litigation Alerts



Keep your litigation team up-to-date with **real-time alerts** and advanced team management tools built for the enterprise, all while greatly reducing PACER spend.

Our comprehensive service means we can handle Federal, State, and Administrative courts across the country.

Advanced Docket Research



With over 230 million records, Docket Alarm's cloud-native docket research platform finds what other services can't. Coverage includes Federal, State, plus PTAB, TTAB, ITC and NLRB decisions, all in one place.

Identify arguments that have been successful in the past with full text, pinpoint searching. Link to case law cited within any court document via Fastcase.

Analytics At Your Fingertips



Learn what happened the last time a particular judge, opposing counsel or company faced cases similar to yours.

Advanced out-of-the-box PTAB and TTAB analytics are always at your fingertips.

API

Docket Alarm offers a powerful API (application programming interface) to developers that want to integrate case filings into their apps.

LAW FIRMS

Build custom dashboards for your attorneys and clients with live data direct from the court.

Automate many repetitive legal tasks like conflict checks, document management, and marketing.

FINANCIAL INSTITUTIONS

Litigation and bankruptcy checks for companies and debtors.

E-DISCOVERY AND LEGAL VENDORS

Sync your system to PACER to automate legal marketing.