

(19) World Intellectual Property Organization
International Bureau



(43) International Publication Date
13 September 2001 (13.09.2001)

PCT

(10) International Publication Number
WO 01/67266 A1

- (51) International Patent Classification⁷: G06F 15/16
- (21) International Application Number: PCT/US01/06600
- (22) International Filing Date: 1 March 2001 (01.03.2001)
- (25) Filing Language: English
- (26) Publication Language: English
- (30) Priority Data:
09/521,186 8 March 2000 (08.03.2000) US
- (71) Applicant: PHATNOISE, INC. [US/US]; 9911 West Pico Boulevard, Suite 808, Los Angeles, CA 90035 (US).
- (72) Inventors: LAU, Dannie, C.; 285 Landeros Drive, Santa Clara, CA 95051 (US). BENYAMIN, Daniel; 3275 Crane Way, Oakland, CA 94602 (US).
- (74) Agents: MAGEN, Burt_ et al.; Vierra Magen Marcus Harmon & DeNiro-LLP, 685 Market Street, Suite 540, San Francisco, CA 94105 (US).
- (81) Designated States (*national*): AE, AG, AL, AM, AT, AU, AZ, BA, BB, BG, BR, BY, BZ, CA, CH, CN, CR, CU, CZ, DE, DK, DM, DZ, EE, ES, FI, GB, GD, GE, GH, GM, HU, ID, IL, IN, IS, JP, KE, KG, KP, KR, KZ, LC, LK, LR, LS, LT, LU, LV, MA, MD, MG, MK, MN, MW, MX, MZ, NO, NZ, PL, PT, RO, RU, SD, SE, SG, SI, SK, SL, TJ, TM, TR, TT, TZ, UA, UG, UZ, VN, YU, ZA, ZW.
- (84) Designated States (*regional*): ARIPO patent (GH, GM, KE, LS, MW, MZ, SD, SL, SZ, TZ, UG, ZW), Eurasian patent (AM, AZ, BY, KG, KZ, MD, RU, TJ, TM), European patent (AT, BE, CH, CY, DE, DK, ES, FI, FR, GB, GR, IE, IT, LU, MC, NL, PT, SE, TR), OAPI patent (BF, BJ, CF, CG, CI, CM, GA, GN, GW, ML, MR, NE, SN, TD, TG).

[Continued on next page]

(54) Title: VEHICLE SOUND SYSTEM

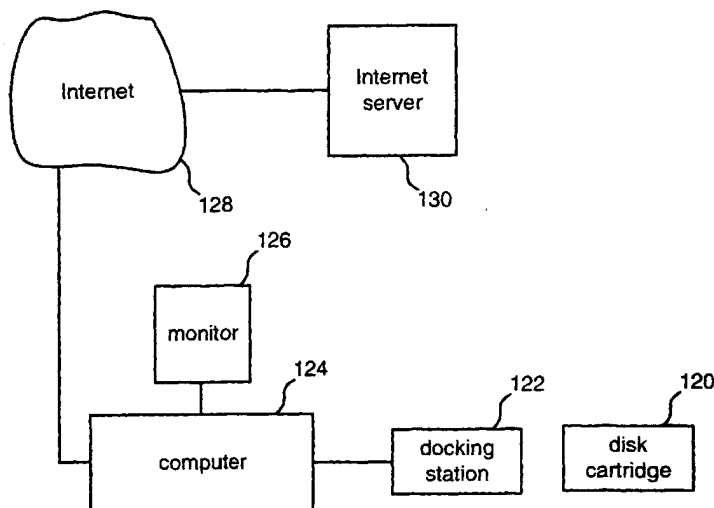

(57) Abstract: A vehicle sound system is disclosed that includes a set of speakers (106, 108, 110, 112), a head unit (104) and a disc changer. In addition to a radio, the head unit also includes a means for playing music downloaded from a computer (124). In one embodiment, the music downloaded from the computer (124) is stored in a compressed format on a removable hard disk drive. The music can be organized using play lists. Software is used to program the head unit (104) to communicate with different disc changers. The head unit (104) also includes a control panel for operating the head unit (104) and the disc changer.

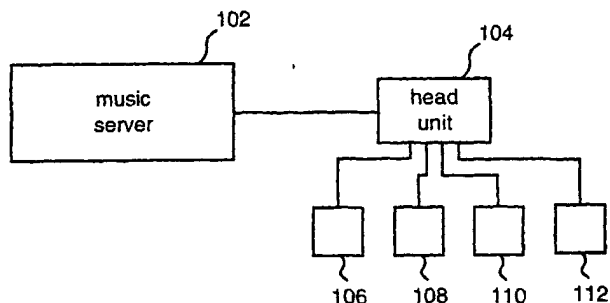

WO 01/67266 A1



Published:

— with international search report

For two-letter codes and other abbreviations, refer to the "Guidance Notes on Codes and Abbreviations" appearing at the beginning of each regular issue of the PCT Gazette.

VEHICLE SOUND SYSTEM

CROSS-REFERENCE TO RELATED APPLICATIONS

This Application is related to the following Applications:

- 5 AUDIO/VISUAL SERVER, by Dannie C. Lau, et al., filed the same day as the present application, Attorney Docket No. PHAT-1000US0 BBM; and
- PLAYLIST MANAGER, by Daniel Benyamin, et al., filed the same day as the present application, Attorney Docket No. PHAT-1001US0 BBM.

Each of these related Applications are incorporated herein by reference.

10

BACKGROUND OF THE INVENTION

Field of the Invention

The present invention is directed to sound system for use in motor vehicles.

15

Description of the Related Art

The automobile audio industry is a growing and successful industry. Most automobiles sold include some type of audio system. For example, many automobiles include a radio, a cassette player and/or a compact disc player. Some automobile audio systems include a disc changer. A disc changer is a device that can hold more than one

20 audio disc and can be used to play songs from any of the discs being stored in the disc changer. Typical disc changers are separate components of a stereo system and can hold six, eight or ten discs such that the discs can be inserted in and removed from the disc changer separately. Examples of disc changers includes audio compact disc changers, audio minidisc changers and CD-ROM disc changers.

25

Part of the reason that automobile audio systems are so popular is because many people want to hear music while they are driving. While listening to a radio is sufficient

for many people, a growing number of drivers prefer to pick and choose what music they will listen to. These drivers prefer audio systems that include a tape deck or a compact disc player.

5 Although there are many audio systems with a compact disc player or tape deck available to the public, these audio systems have drawbacks. First, these systems can only store a limited amount of music. That is, a system with a tape deck can only store the maximum amount of music that fits on a tape, which often is sixty minutes or one hundred and twenty minutes. Compact discs typically hold approximately seventy four minutes of music. Thus, these devices have a limited amount of music that can be stored.

10 Second, if a user is listening to a first tape or compact disc and chooses to listen to a different tape or compact disc that is not already stored in the player, the user must remove the compact disc or tape and insert a different one. This can be a difficult and dangerous maneuver while driving an automobile. Third, tape decks and compact disc players require the purchase of physical media. Although music can be stored on a

15 computer's memory, prior art stereos require tapes or compact discs for each set of songs. Thus, extra resources are wasted manufacturing and purchasing the media. Fourth, the media is vulnerable. For example, compact discs can scratch or break. Cassettes can wear out or break.

20 Additionally, there is a new trend to order music online. Consumers can purchase music over the Internet by downloading the music. As downloading music becomes more popular, consumers will want to play this downloaded music in their automobiles. An automobile stereo that includes a compact disc player to play music would require the user to purchase a compact disc recorder and burn a compact disc in order to play the downloaded music. Thus, there is a need for an improved

25 automobile audio system that does not require cassettes or compact discs, can be used with reusable media and can play music downloaded from a computer or other device.

One solution that is currently available is the portable solid state music player, which uses flash memory to store music files in digitally compressed formats. Some of these devices include a removable memory such as compact flash card. The compact flash card can be removed from the player and inserted into a compact flash card reader/writer which is connected to a computer. Other music players connect directly to a computer for downloading music. These portable solid state music players typically are shipped with headphones for listening to the music. Alternatively, a user can purchase an adapter so that the output of the music player connects to the cassette input of an automobile stereo. While this solution solves some of the problems identified above, using the portable solid state music player with an automobile stereo is not satisfactory. First, sending the sound signal through the cassette deck causes a degradation in sound quality. Second, using a solid state music player with a car stereo as described above can be dangerous because all of the controls are on the portable player, rather than on the dashboard or another convenient location for the driver. Third, while music can be sent from the portable player to the car stereo, the car stereo cannot communicate back to a music player so the user is unable to use the controls of the car stereo to control the music player. Additionally, many portable music players tend to have a limited amount of storage, there is no convenient location to store the music player while driving and the solution is not available if there is no tape deck.

Another solution includes an in-dash car stereo which plays music stored in MP3 format. This solution, however, has drawbacks. First, to store music on the stereo, the entire stereo is removed from the vehicle which can be difficult and can break the stereo. Second, the stereo does not work with a disc changer; therefore, a user who has a collection of compact discs can no longer use that collection.

Thus, there is a need for an improved automobile audio system.

Explore Litigation Insights

Docket Alarm provides insights to develop a more informed litigation strategy and the peace of mind of knowing you're on top of things.

Real-Time Litigation Alerts



Keep your litigation team up-to-date with **real-time alerts** and advanced team management tools built for the enterprise, all while greatly reducing PACER spend.

Our comprehensive service means we can handle Federal, State, and Administrative courts across the country.

Advanced Docket Research



With over 230 million records, Docket Alarm's cloud-native docket research platform finds what other services can't. Coverage includes Federal, State, plus PTAB, TTAB, ITC and NLRB decisions, all in one place.

Identify arguments that have been successful in the past with full text, pinpoint searching. Link to case law cited within any court document via Fastcase.

Analytics At Your Fingertips



Learn what happened the last time a particular judge, opposing counsel or company faced cases similar to yours.

Advanced out-of-the-box PTAB and TTAB analytics are always at your fingertips.

API

Docket Alarm offers a powerful API (application programming interface) to developers that want to integrate case filings into their apps.

LAW FIRMS

Build custom dashboards for your attorneys and clients with live data direct from the court.

Automate many repetitive legal tasks like conflict checks, document management, and marketing.

FINANCIAL INSTITUTIONS

Litigation and bankruptcy checks for companies and debtors.

E-DISCOVERY AND LEGAL VENDORS

Sync your system to PACER to automate legal marketing.