

(12)

(21) **2 347 648**

(51) Int. Cl. 7: **H04B 7/15, H04B 7/00, H04H 1/00, H04Q 7/22**

(22) **15.05.2001**

(30) **60/209,019 US 01.06.2000**

(71) **INTERNATIONAL BUSINESS MACHINES CORPORATION, New Orchard Road, ARMONK, XX (US).**

(72) **KANDLER, GERSHON (IL).**

(74) **ROSEN, ARNOLD**

(54) **FOURNITURE SANS FIL DE CONTENU AUDIO**
(54) **WIRELESS PROVISION OF AUDIO CONTENT**

(57)

Apparatus for in-vehicle provision of audio content to a listener. The apparatus includes a cellular telephone adapted to receive broadcast radio content over a wireless network, and an in-vehicle audio system adapted to be fixedly installed in a vehicle, and coupled to receive the broadcast radio content from the cellular telephone, and to play the content in the vehicle.

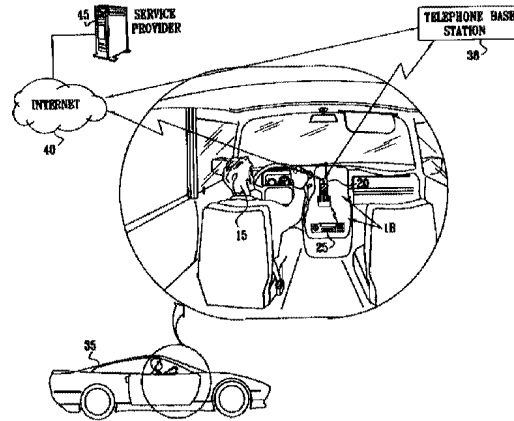

(22) Date de dépôt/Filing Date: 2001/05/15
(41) Mise à la disp. pub./Open to Public Insp.: 2001/12/01
(30) Priorité/Priority: 2000/06/01 (60/209,019) US

(51) Cl.Int.⁷/Int.Cl.⁷ H04B 7/15, H04Q 7/22, H04H 1/00,
H04B 7/00
(71) Demandeur/Applicant:
INTERNATIONAL BUSINESS MACHINES
CORPORATION, US
(72) Inventeur/Inventor:
KANDLER, GERSHON, IL
(74) Agent: ROSEN, ARNOLD

(54) Titre : FOURNITURE SANS FIL DE CONTENU AUDIO
(54) Title: WIRELESS PROVISION OF AUDIO CONTENT

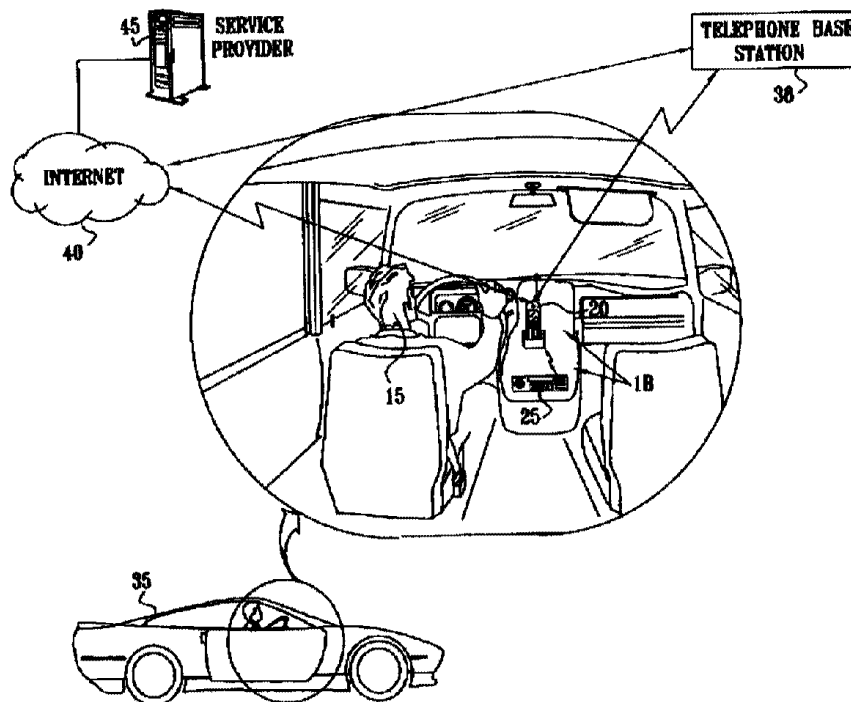

(57) Abrégé/Abstract:

Apparatus for in-vehicle provision of audio content to a listener. The apparatus includes a cellular telephone adapted to receive broadcast radio content over a wireless network, and an in-vehicle audio system adapted to be fixedly installed in a vehicle, and coupled to receive the broadcast radio content from the cellular telephone, and to play the content in the vehicle.

Canada

<http://opic.gc.ca> • Ottawa-Hull K1A 0C9 • <http://cipo.gc.ca>

OPIC • CIPQ 191

OPIC



CIPO

ABSTRACT

WIRELESS PROVISION OF AUDIO CONTENT

- 5 Apparatus for in-vehicle provision of audio content to a listener. The apparatus includes a cellular telephone adapted to receive broadcast radio content over a wireless network, and an in-vehicle audio system adapted to be fixedly installed in a vehicle, and coupled to receive the broadcast radio content from the cellular telephone, and to play the content in the vehicle.

IL9-2000-0037

WIRELESS PROVISION OF AUDIO CONTENT

FIELD OF THE INVENTION

The present invention relates to the field of provision of audio content, particularly wireless provision of audio content via a cellular telephone.

5 BACKGROUND OF THE INVENTION

The majority of cars and other vehicles contain in-vehicle audio systems containing relatively high quality audio components such as amplifiers and speakers. Such in-vehicle audio systems typically include radios, and cassette, CD and minidisk players, and the like. However, the range of audio content available to a listener of in-vehicle audio devices is limited.

10 A listener to a radio is limited temporally to the programming available at that time. If a listener misses a desired radio program at its normal broadcast time, he is unable to listen to that program later, at a time convenient for him, unless he recorded it during broadcast. A radio listener is also limited geographically to the programming broadcast from a within-range radio transmitter. It is currently not possible for a radio listener to travel abroad and still receive broadcasts from his
15 home country's local radio stations on an in-vehicle radio. There is thus a need for a method for listening to a radio program via an in-vehicle radio system, while the radio program is not being currently transmitted on an in-range transmitter, without the listener having to pre-record the program.

A listener to in-vehicle audio devices, such as a cassette or CD player, is limited to the
20 selection of prerecorded audio content, typically music, that he has available in the appropriate format.

A large amount of audio content, including both music and spoken content, is available over the Internet. The majority of in-vehicle audio systems are not Internet-enabled, however.

A large number of listeners to in-vehicle audio devices also possess cellular phones. New
25 generations of cellular phones are Internet-enabled, allowing audio content to be downloaded from the Internet. The sound quality from cellular phones is typically poor as they are designed to

minimize size and weight and are intended to be used by a single user, while being held close to the ear. Cellular phones are not designed for broadcasting music to a number of listeners. There is thus also a need for apparatus and a method for improving the sound quality of audio content downloaded from a network such as the Internet, through a cellular phone.

5

SUMMARY OF THE INVENTION

The present invention seeks to provide apparatus and methods for receiving audio content, typically in the form of files, from a network such as the Internet via a cellular phone, and for playing the downloaded audio content over regular radio or stereo equipment. In one embodiment, the radio or stereo equipment is located within a vehicle. The vehicle stereo provides high quality sound, not available from the cellular telephone, and may also provide a buffering memory, *e.g.*, a hard disk, for storing downloaded audio files for playback. The cellular phone provides a user interface and data channel to an application server as an extension to the car radio/stereo.

In a preferred embodiment, the cellular phone is Internet enabled, using a protocol such as WAP (Wireless Access Protocol), to retrieve audio files from the Internet. In an alternative embodiment, the cellular phone uses packet-oriented cellular protocols and networks. A typical, but non-limiting, example of a packet-oriented cellular protocol is GPRS (General Packet Radio Service), which is a data service currently offered in some GSM networks.

In a preferred embodiment, the cellular phone and the radio or stereo equipment are able to communicate with each other over a short-range wireless channel, using a communication protocol such as Bluetooth™.

In a preferred embodiment, a user specifies the desired radio stations, or individual radio programs, typically by presetting a radio to the desired program or station. This information is transmitted from the radio to the telephone, which then contacts an application server which has an accessible archive of the radio station's programs, and downloads the requested programming, typically as audio files. The audio content is transferred from the telephone to the radio for playback to the user. Thus, the user is able to listen to programming at substantially any desired time and place, without being bound by the geographical limits and programming schedule of a given radio station.

IL9-2000-0037

2

Explore Litigation Insights

Docket Alarm provides insights to develop a more informed litigation strategy and the peace of mind of knowing you're on top of things.

Real-Time Litigation Alerts



Keep your litigation team up-to-date with **real-time alerts** and advanced team management tools built for the enterprise, all while greatly reducing PACER spend.

Our comprehensive service means we can handle Federal, State, and Administrative courts across the country.

Advanced Docket Research



With over 230 million records, Docket Alarm's cloud-native docket research platform finds what other services can't. Coverage includes Federal, State, plus PTAB, TTAB, ITC and NLRB decisions, all in one place.

Identify arguments that have been successful in the past with full text, pinpoint searching. Link to case law cited within any court document via Fastcase.

Analytics At Your Fingertips



Learn what happened the last time a particular judge, opposing counsel or company faced cases similar to yours.

Advanced out-of-the-box PTAB and TTAB analytics are always at your fingertips.

API

Docket Alarm offers a powerful API (application programming interface) to developers that want to integrate case filings into their apps.

LAW FIRMS

Build custom dashboards for your attorneys and clients with live data direct from the court.

Automate many repetitive legal tasks like conflict checks, document management, and marketing.

FINANCIAL INSTITUTIONS

Litigation and bankruptcy checks for companies and debtors.

E-DISCOVERY AND LEGAL VENDORS

Sync your system to PACER to automate legal marketing.