



[54] METHOD OF FABRICATING AN INJECTED MOLDED MOTOR ASSEMBLY

[76] Inventors: Bradley A. Trago, 922 Cerasus Dr., Rockford, Ill. 61108; Edward J. Byrnes, 116 Woodland Ct., #1D, Carpentersville, Ill. 60110; Griff D. Neal, 2600 N. Southport Ave., Unit 31, Chicago, Ill. 60614

[21] Appl. No.: 415,639

[22] Filed: Apr. 3, 1995

[51] Int. Cl.⁶ H02K 15/04

[52] U.S. Cl. 29/596; 264/272.2; 310/42; 310/43; 310/90

[58] Field of Search 29/596, 598; 310/42, 310/43, 90, 71; 264/272.2, 272.19

[56] References Cited

U.S. PATENT DOCUMENTS

2,916,642	12/1959	Macks	310/90
3,046,604	7/1962	Graham et al.	
3,156,076	11/1964	Origoni et al.	29/596
3,258,624	6/1966	Turk	310/261
3,433,986	3/1969	Arutunoff	310/90
4,015,154	3/1977	Tanaka et al.	29/596
4,029,977	6/1977	Chai et al.	310/49
4,200,344	4/1980	Binns et al.	310/90
4,382,199	5/1983	Isaacson	310/90
4,538,084	8/1985	Kawada et al.	310/217
4,549,105	10/1985	Yamamoto et al.	310/43 X
4,626,725	12/1986	Kawada et al.	310/89
4,696,631	9/1987	Nitt	29/596 X
4,712,028	12/1987	Horber	310/49
4,713,570	12/1987	Mastromattei	310/154
4,763,034	8/1988	Gamble	310/181
4,781,610	11/1988	Mercer	310/71

4,841,190	6/1989	Matsushita et al.	310/257
4,922,604	5/1990	Marshall et al.	29/598
5,008,572	4/1991	Marshall et al.	310/45
5,073,735	12/1991	Takagi	310/43 X
5,191,698	3/1993	Sumi et al.	29/596
5,331,237	7/1994	Ichimura	310/44
5,333,957	8/1994	Yip et al.	385/484

FOREIGN PATENT DOCUMENTS

0553811	8/1993	European Pat. Off.	
0562146	2/1959	Italy	264/272.2
56-094952	7/1981	Japan	
59-105864	6/1984	Japan	
59-220051	12/1984	Japan	
31120	1/1995	Japan	
WO 91/09441	6/1991	WIPO	

Primary Examiner—Carl E. Hall
Attorney, Agent, or Firm—Leydig, Voit & Mayer

[57] ABSTRACT

An electrical motor and the process for forming that motor utilizes injection molding techniques to unitize the stator assembly. The stator assembly includes a stator lamination stack and preferably a metal front end cap which is secured to the lamination stack after the lamination stack is insulated and wound. The windings are terminated at a plurality of conductive pins fusion welded to the terminating ends of the windings. The stator assembly with front end cap in place is positioned in an injection molding die. Pressure is applied to the die, and molten plastic is injected under pressure to fill voids in the stator assembly, and also to form a plastic mass which will serve as the rear end cap. The rear end cap is also molded with a connector portion which fixes the conductive pins in place as a part of the connector. A bore formed in the stator assembly provides mounting surfaces for bearings on a rotor assembly.

28 Claims, 10 Drawing Sheets

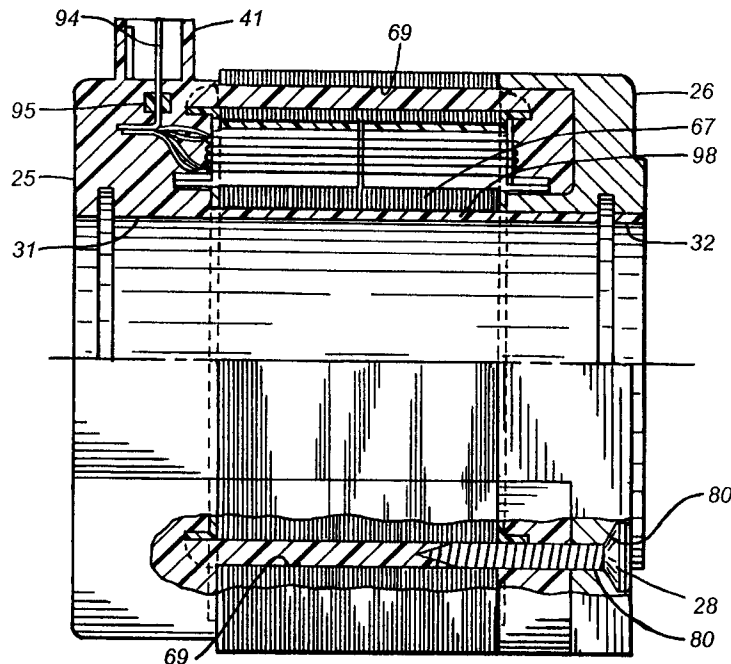

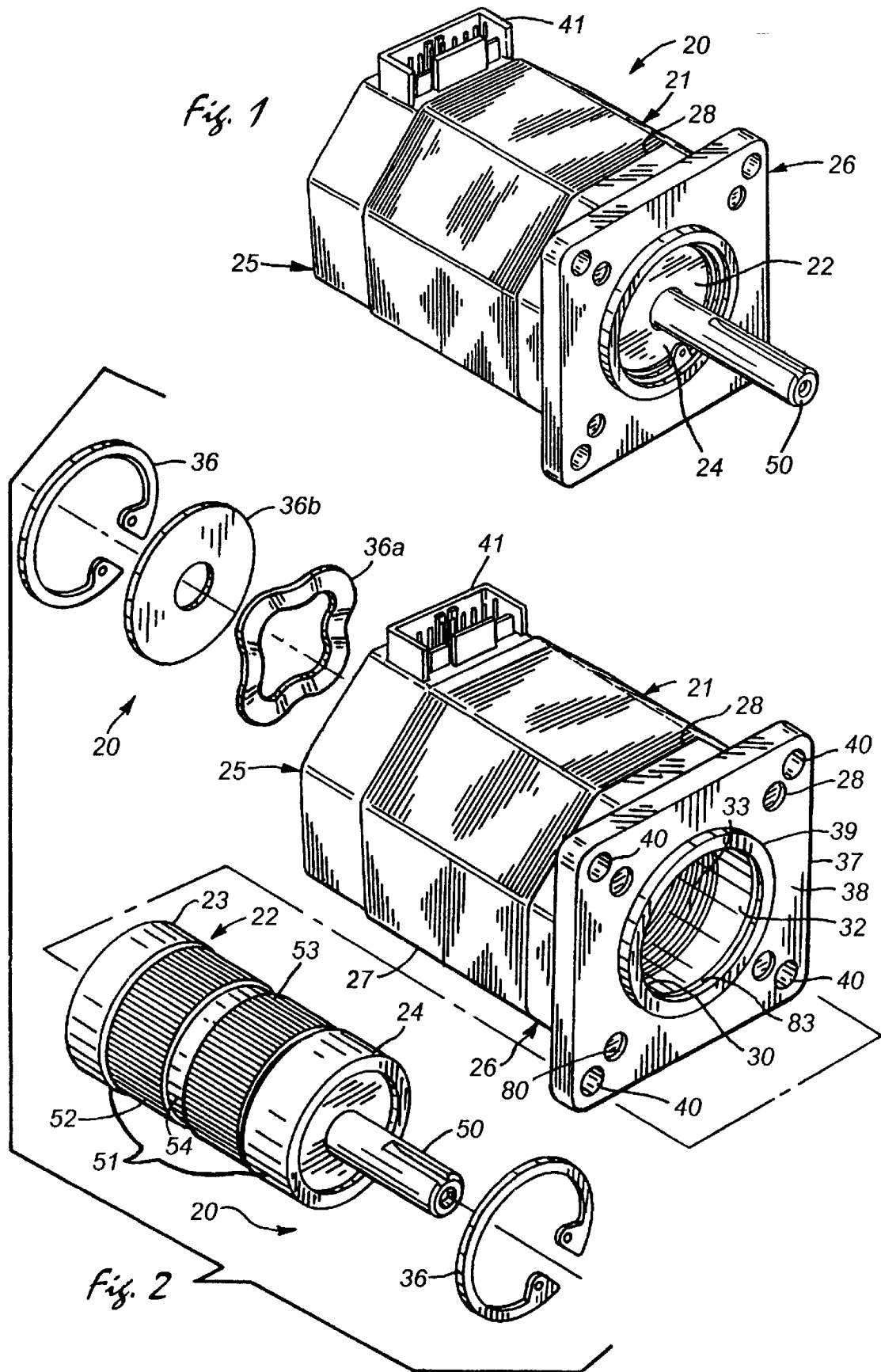

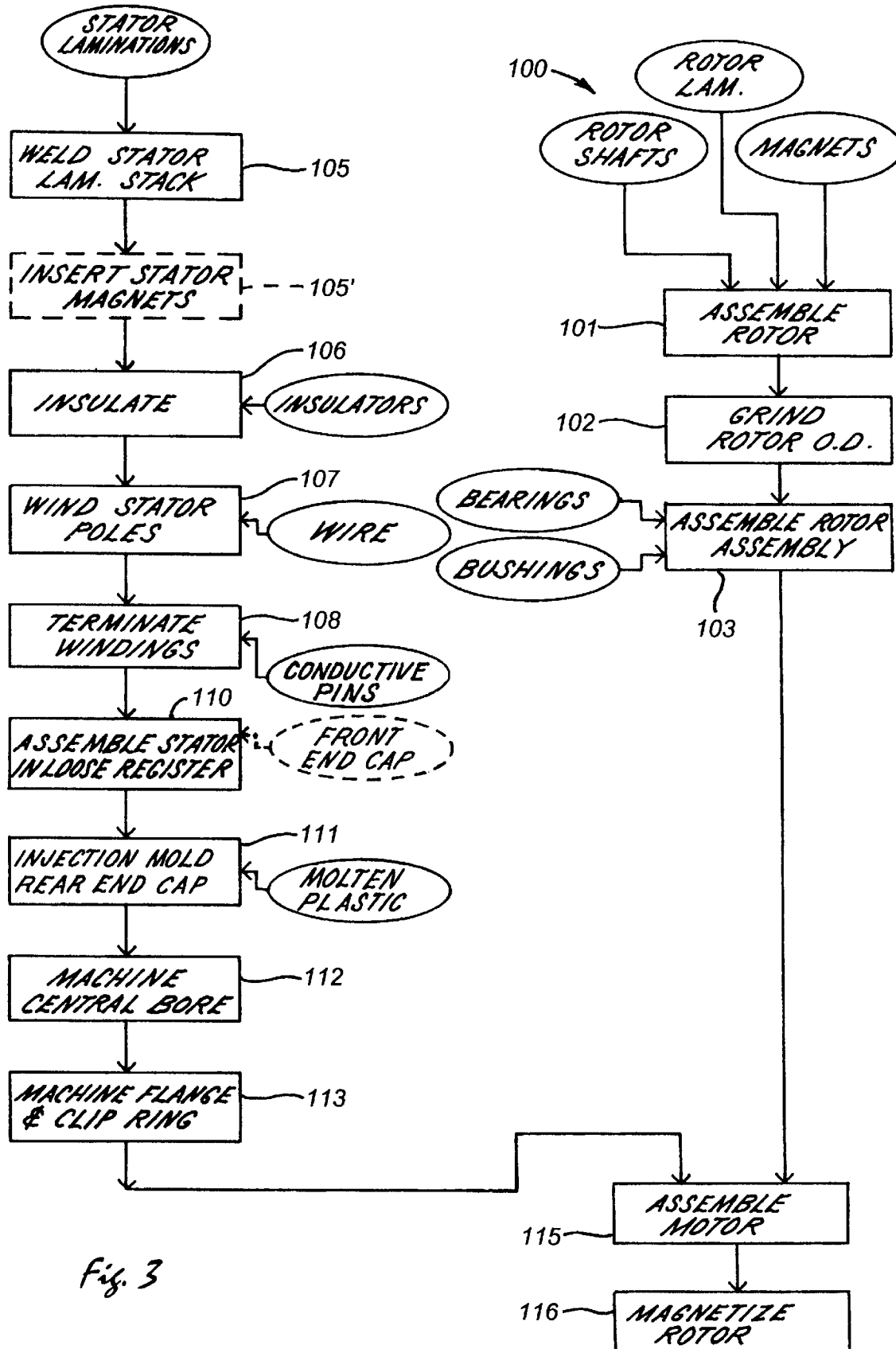

Fig. 3

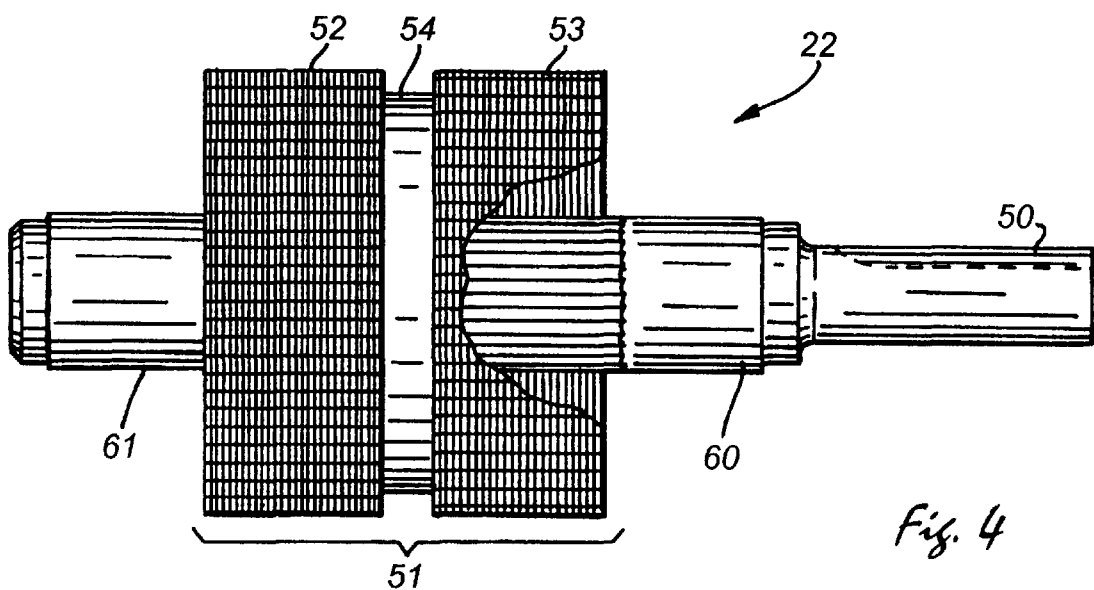

Fig. 4

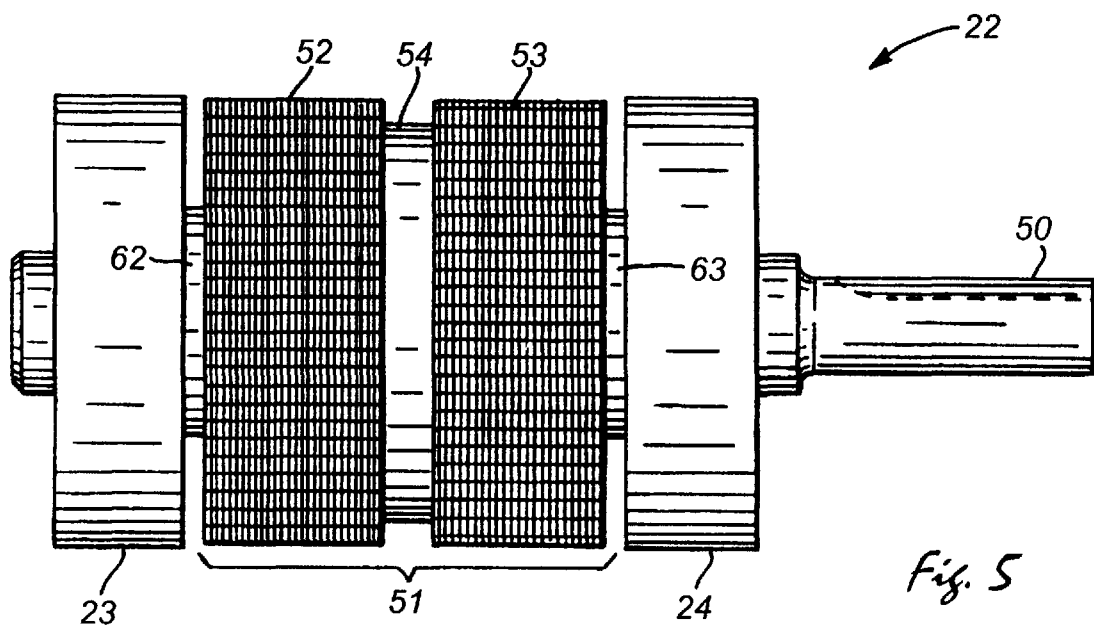
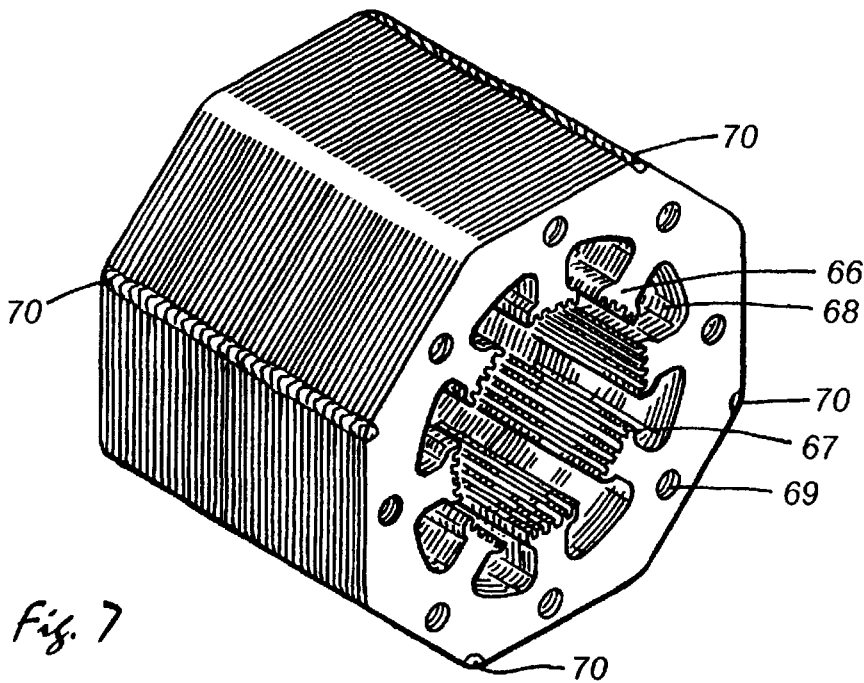
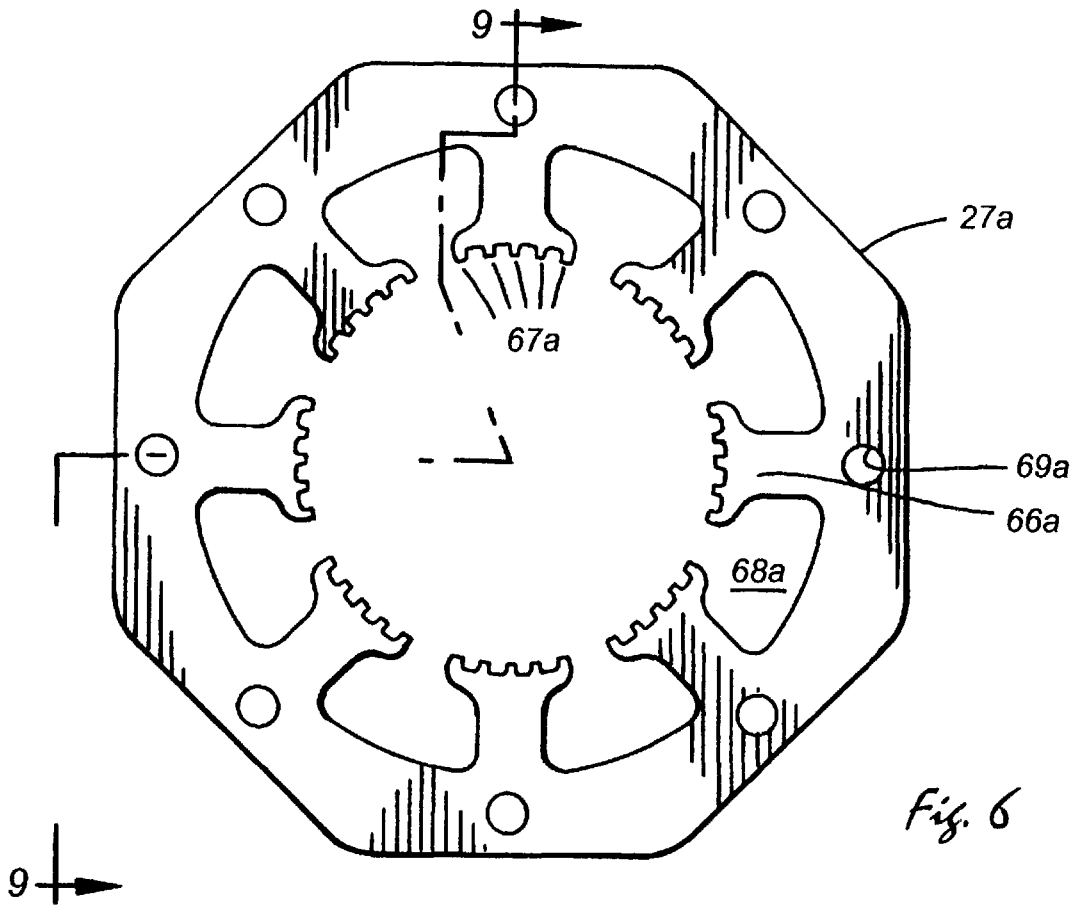

Fig. 5



Explore Litigation Insights

Docket Alarm provides insights to develop a more informed litigation strategy and the peace of mind of knowing you're on top of things.

Real-Time Litigation Alerts



Keep your litigation team up-to-date with **real-time alerts** and advanced team management tools built for the enterprise, all while greatly reducing PACER spend.

Our comprehensive service means we can handle Federal, State, and Administrative courts across the country.

Advanced Docket Research



With over 230 million records, Docket Alarm's cloud-native docket research platform finds what other services can't. Coverage includes Federal, State, plus PTAB, TTAB, ITC and NLRB decisions, all in one place.

Identify arguments that have been successful in the past with full text, pinpoint searching. Link to case law cited within any court document via Fastcase.

Analytics At Your Fingertips



Learn what happened the last time a particular judge, opposing counsel or company faced cases similar to yours.

Advanced out-of-the-box PTAB and TTAB analytics are always at your fingertips.

API

Docket Alarm offers a powerful API (application programming interface) to developers that want to integrate case filings into their apps.

LAW FIRMS

Build custom dashboards for your attorneys and clients with live data direct from the court.

Automate many repetitive legal tasks like conflict checks, document management, and marketing.

FINANCIAL INSTITUTIONS

Litigation and bankruptcy checks for companies and debtors.

E-DISCOVERY AND LEGAL VENDORS

Sync your system to PACER to automate legal marketing.