

UNITED STATES PATENT AND TRADEMARK OFFICE

BEFORE THE PATENT TRIAL AND APPEAL BOARD

VIZIO, INC.,
Petitioner,

v.

NICHIA CORPORATION,
Patent Owner.

0

Case IPR2017-00558
Patent 8,309,375 B2

Before BRIAN J. McNAMARA, STACEY G. WHITE, and
NABEEL U. KHAN, *Administrative Patent Judges*.

WHITE, *Administrative Patent Judge*.

DECISION
Denying Institution of *Inter Partes* Review
37 C.F.R. § 42.108

I. INTRODUCTION

A. Background

Vizio, Inc. (“Petitioner”) filed a Petition (Paper 1, “Pet.”) seeking to institute an *inter partes* review of claims 1 and 4 of U.S. Patent No. 8,309,375 B2 (Ex. 1001, “the ’375 patent”) pursuant to 35 U.S.C. §§ 311–319. Nichia Corporation (“Patent Owner”) filed a Preliminary Response. (Paper 8, “Prelim. Resp.”). We have jurisdiction under 35 U.S.C. § 314(a), which provides that an *inter partes* review may not be instituted “unless . . . there is a reasonable likelihood that the petitioner would prevail with respect to at least 1 of the claims challenged in the petition.”

Petitioner contends the challenged claims are unpatentable under 35 U.S.C. § 103 on the following specific grounds (Pet. 17–82):

| References | Claims Challenged |
|---|-------------------|
| Baretz ¹ and Pinnow ² | 1 and 4 |
| Baretz, Pinnow, Nakamura ³ , and Schuil ⁴ | 1 and 4 |

For reasons discussed below, we deny Petitioner’s request to institute *inter partes* review of claims 1 and 4 of the ’375.

B. Related Proceedings

We have been informed that *Nichia Corp. v. VIZIO, Inc.*, C.A. No. C.A. No. 8:16-cv-545 (C.D. Cal.), may be impacted by this proceeding. Pet. 2. In addition, Petitioner has filed petitions seeking *inter partes* review

¹ U.S. Patent No. 6,600,175 (Ex. 1004, “Baretz”).

² U.S. Patent No. 3,699,478 (Ex. 1005, “Pinnow”).

³ Shuji Nakamura et al., “High-Power InGaN Single-Quantum-Well-Structure Blue and Violet Light-Emitting Diodes,” *APPLIED PHYSICS LETTERS* 67, 1868 (1995) (Ex. 1014, “Nakamura”).

⁴ U.S. Patent No. 4,024,070 (Ex. 1015, “Schuil”).

of several related patents, 7,915,631 (IPR2017-00551), 7,901,959 (IPR2017-00552), and 7,855,092 (IPR2017-00556). *See id.* at 2–3.

C. The '375 patent

The '375 patent describes a method for manufacturing a light emitting diode (“LED”). *See* Ex. 1001, Abstract. As described in the specification, prior attempts to emit white light from LEDs had unsatisfactory results due to “variations in the tone, luminance and other factors of the light emitting component” and in addition, it was sometimes necessary to use complex circuitry to compensate for variations between materials used to create the LEDs. *Id.* at 1:55–61. The '375 patent purports “to solve the problems described above and provide a light emitting device which experiences only extremely low degrees of deterioration in emission light intensity, light emission efficiency and color shift over a long time of use with high luminance.” *Id.* at 3:1–7. Figure 1 of the '375 patent is reproduced below.

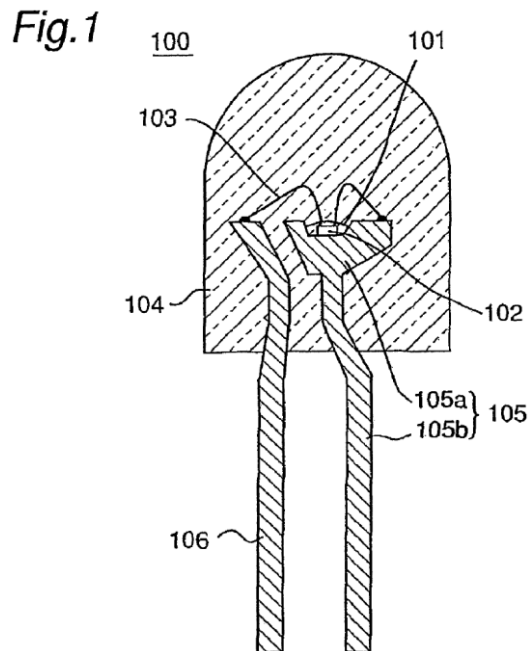

Figure 1 is a schematic sectional view of a lead type LED. *Id.* at 4:59–61. LED 100 has light emitting component 102, which is installed in cup 105a. *Id.* at 8:40–41. The light emitting component has an active layer comprising a gallium nitride based semiconductor containing indium and is capable of emitting a blue color light. *Id.* at Abstract. Coating resin 101 fills cup 105a and the resin contains a specified phosphor to cover light emitting component 102. *Id.* at 8:41–43. Light emitting component 102, which is also known as an LED chip, “excites the phosphor contained in the coating resin 101 to generate fluorescent light having a wavelength different from that of LED light, so that the fluorescent light emitted by the phosphor and LED light which is output without contributing to the excitation of the phosphor are mixed and output.” *Id.* at 8:49–54. Thus, LED 100 emits light having a different wavelength than the light emitted by the LED chip. *Id.* at 8:54–56.

D. Challenged Claims

Petitioner challenges claims 1 and 4 of the ’375 patent, of which claim 1 is independent. The challenged claims are reproduced below:

1. A method for manufacturing a light emitting device comprising:

preparing a light emitting component having an active layer of a semiconductor, said active layer comprising a gallium nitride based semiconductor containing indium and being capable of emitting a blue color light having a spectrum with a peak wavelength within the range from 420 to 490 nm;

preparing a phosphor capable of absorbing a part of the blue color light emitted from said light emitting component and emitting a yellow color light having a broad emission spectrum comprising a peak wavelength existing around

the range from 510 to 600 nm and a tail continuing beyond 700 nm, wherein selection of said phosphor is controlled based on an emission wavelength of said light emitting component; and

combining said light emitting component and said phosphor so that the blue color light from said light emitting component and the yellow color light from said phosphor are mixed to make a white color light, wherein a chromaticity point of the white color light is on a straight line connecting a point of chromaticity of the blue color light and a point of chromaticity of the yellow color light, and

wherein a content of said phosphor in said light emitting device is selected to obtain a desired chromaticity of the white color light.

4. The method for manufacturing a light emitting device according to claim 1, wherein the emission spectrum of said phosphor comprises a peak wavelength existing around the range from 530 to 570 nm and a tail continuing beyond 700 nm.

Ex. 1001, 30:55–31:14, 31:21–26.

II. IDENTIFICATION OF REAL PARTIES-IN-INTEREST

Petitioner declares that it is the real party-in-interest (“RPI”) pursuant to 37 C.F.R. § 42.8(b)(1). Pet. 2. That rule requires the Petition to “[i]dentify *each* real party-in-interest.” 37 C.F.R. § 42.8(b)(1) (emphasis added). Patent Owner questions whether this is a complete listing of RPIs because “facts presently available to Nichia suggest that TCL Multimedia Technology Holdings Ltd. and its subsidiary, TTE Technology, Inc. (together, ‘TCL’), may also be real parties-in-interest.” Prelim. Resp. 7.

Explore Litigation Insights

Docket Alarm provides insights to develop a more informed litigation strategy and the peace of mind of knowing you're on top of things.

Real-Time Litigation Alerts



Keep your litigation team up-to-date with **real-time alerts** and advanced team management tools built for the enterprise, all while greatly reducing PACER spend.

Our comprehensive service means we can handle Federal, State, and Administrative courts across the country.

Advanced Docket Research



With over 230 million records, Docket Alarm's cloud-native docket research platform finds what other services can't. Coverage includes Federal, State, plus PTAB, TTAB, ITC and NLRB decisions, all in one place.

Identify arguments that have been successful in the past with full text, pinpoint searching. Link to case law cited within any court document via Fastcase.

Analytics At Your Fingertips



Learn what happened the last time a particular judge, opposing counsel or company faced cases similar to yours.

Advanced out-of-the-box PTAB and TTAB analytics are always at your fingertips.

API

Docket Alarm offers a powerful API (application programming interface) to developers that want to integrate case filings into their apps.

LAW FIRMS

Build custom dashboards for your attorneys and clients with live data direct from the court.

Automate many repetitive legal tasks like conflict checks, document management, and marketing.

FINANCIAL INSTITUTIONS

Litigation and bankruptcy checks for companies and debtors.

E-DISCOVERY AND LEGAL VENDORS

Sync your system to PACER to automate legal marketing.