

【0025】

本願発明に用いられるセリウムで付活されたイットリウム・アルミニウム酸化物系蛍光体である緑色系が発光可能なYAG系蛍光体では、ガーネット構造のため、熱、光及び水分に強く、図4（A）の実線の例の如く励起スペクトルのピークが450nm付近にさせることができる。また、発光ピークも図4（B）の実線の例の如く510nm付近にあり700nmまで裾を引くブロードな発光スペクトルを持つ。一方、セリウムで付活されたイットリウム・アルミニウム酸化物系蛍光体である赤色系が発光可能なYAG系蛍光体でも、ガーネット構造であり熱、光及び水分に強く、図4（A）の波線の例の如く励起スペクトルのピークが450nm付近にさせることができる。また、発光ピークも図4（B）の波線の例の如く600nm付近にあり750nmまで裾を引くブロードな発光スペクトルを持つ。

【0026】

ガーネット構造を持ったYAG系蛍光体の組成の内、Alの一部をGaで置換することで発光波長が短波長側にシフトし、また組成のYの一部をGd及び／又はLaで置換することで、発光波長が長波長側へシフトする。AlのGaへの置換は、発光効率と発光波長を考慮してGa：Al＝1：1から4：6が好ましい。同様に、Yの一部をGd及び／又はLaで置換することは、Y：Gd及び／又はLa＝9：1から1：9であり、より好ましくは、Y：Gd及び／又はLa＝1：4から2：3である。置換が2割未満では、緑色成分が大きく赤色成分が少なくなる。また、8割以上では、赤み成分が増えるものの輝度が急激に低下する。

【0027】

このようなフォトルミネセンス蛍光体は、Y、Gd、Ce、La、Al、Sm及びGaの原料として酸化物、又は高温で容易に酸化物になる化合物を使用し、それらを化学量論比で十分に混合して原料を得る。又は、Y、Gd、Ce、La、Smの希土類元素を化学量論比で酸に溶解した溶解液を蔞酸で共沈したものを焼成して得られる共沈酸化物と、酸化アルミニウム、酸化ガリウムとを混合して混合原料を得る。これにフラックスとしてフッ化アンモニウム等のフッ化物を適

量混合して坩堝に詰め、空气中1350～1450°Cの温度範囲で2～5時間焼成して焼成品を得、次に焼成品を水中でボールミルして、洗浄、分離、乾燥、最後に篩を通すことで得ることができる。

【0028】

組成の異なる2種類以上のセリウムで付活されたイットリウム・アルミニウム酸化物系蛍光体は、混合させて用いても良いし、それぞれ独立して配置させても良い。蛍光体をそれぞれ独立して配置させる場合、発光素子から光をより短波長側で吸収発光しやすい蛍光体、それよりも長波長側で吸収発光しやすい蛍光体の順に配置させることが好ましい。これによって効率よく吸収及び発光させることができる。

【0029】

(発光素子102、202、302)

本願発明に用いられる発光素子とは、組成の異なる2種類以上のセリウムで付活されたイットリウム・アルミニウム酸化物系蛍光体をそれぞれ効率良く励起できる窒化物系化合物半導体が挙げられる。発光素子であるLEDチップは、MOCVD法等により基板上にAlN、InN、GaN、InGaNやInGaAlN等の半導体を発光層として形成させることができる。半導体の構造としては、MIS接合、PIN接合やPN接合などを有するホモ構造、ヘテロ構造あるいはダブルヘテロ構成のものが挙げられる。また、半導体活性層を量子効果が生ずる薄膜に形成させた単一量子井戸構造や多重量子井戸構造とすることもできる。半導体層の材料、構造やその混晶度によって発光波長を種々選択することができるが、フォトルミネセンス蛍光物質を効率よく励起させるためにフォトルミネセンス蛍光物質の発光波長よりも短い発光波長を発光することが好ましい。

【0030】

半導体基板にはサファイヤ、スピネル、SiC、Si、ZnO、GaN等の材料が好適に用いられる。結晶性の良い窒化物系化合物半導体を形成させるためにはサファイヤ基板を用いることが好ましい。このサファイヤ基板上にGaN、AlN等のバッファ層を形成しその上にPN接合を有する窒化物系化合物半導体を形成させることができる。窒化ガリウム系半導体は、不純物をドーブしない状

態でN型導電性を示す。発光効率を向上させるなど所望のN型窒化ガリウム半導体を形成させる場合は、N型ドーパントとしてSi、Ge、Se、Te、C等を適宜導入することが好ましい。一方、P型窒化ガリウム半導体を形成させる場合は、P型ドーパントであるZn、Mg、Be、Ca、Sr、Ba等をドーブさせる。窒化ガリウム系化合物半導体は、P型ドーパントをドーブしただけではP型化しにくいいためP型ドーパント導入後に、炉による加熱、低電子線照射、プラズマ照射等によりアニールすることでP型化させることが好ましい。エッチングなどによりP型半導体及びN型半導体の露出面を形成させた後、半導体層上にスパッタリング法や真空蒸着法などを用いて所望の形状の各電極を形成させる。

【0031】

次に、形成された半導体ウエハー等をダイヤモンド製の刃先を有するブレードが回転するダイシングソーにより直接フルカットするか、又は刃先幅よりも広い幅の溝を切り込んだ後（ハーフカット）、外力によって半導体ウエハーを割る。あるいは、先端のダイヤモンド針が往復直線運動するスクライバーにより半導体ウエハーに極めて細いスクライブライン（経線）を例えば碁盤目状に引いた後、外力によってウエハーを割り半導体ウエハーからチップ状にカットする。このようにして窒化ガリウム系化合物半導体である発光素子を形成させることができる。

【0032】

本願発明の発光装置において白色系を発光させる場合は、フォトルミネセンス蛍光体との混色等を考慮して発光素子の主発光波長は400nm以上530nm以下内にあることが好ましく、420nm以上490nm以下内にあることがより好ましい。LEDチップとフォトルミネセンス蛍光体との効率をそれぞれより向上させるためには、450nm以上475nm以下内にあることがさらに好ましい。このような発光素子は、単色性ピーク波長を持つといってもある程度のスペクトル幅を持つため演色性の高い発光装置を形成させることができる。

【0033】

(導電性ワイヤー103、303)

導電性ワイヤーとしては、発光素子102、302の電極とのオーミック性、

機械的接続性、電気伝導性及び熱伝導性がよいものが求められる。熱伝導度としては $0.01 \text{ cal/cm}^2/\text{cm}/^\circ\text{C}$ 以上が好ましく、より好ましくは $0.5 \text{ cal/cm}^2/\text{cm}/^\circ\text{C}$ 以上である。また、作業性などを考慮して導電性ワイヤーの直径は、好ましくは、 $\Phi 10 \mu\text{m}$ 以上、 $\Phi 45 \mu\text{m}$ 以下である。このような導電性ワイヤーとして具体的には、金、銅、白金、アルミニウム等の金属及びそれらの合金を用いた導電性ワイヤーが挙げられる。このような導電性ワイヤーは、各LEDチップの電極と、インナー・リード306及びマウント・リード305などと、をワイヤーボンディング機器によって容易に接続させることができる。

【0034】

(マウント・リード305)

マウント・リード305としては、発光素子302を配置させるものであり、ダイボンド機器などで発光素子であるLEDチップ302を積載するのに十分な大きさがあれば良い。また、LEDチップを複数設置しマウント・リードをLEDチップの共通電極として利用する場合においては、十分な電気伝導性とボンディングワイヤー等との接続性が求められる。また、マウント・リード上のカップ内にLEDチップを配置すると共に蛍光体を内部に充填させる場合は、近接して配置させた別の発光ダイオードからの光により疑似点灯することを防止させることができる。

【0035】

LEDチップ302とマウント・リード305のカップとの接着は熱硬化性樹脂などによって行うことができる。具体的には、エポキシ樹脂、アクリル樹脂やイミド樹脂などが挙げられる。また、フェースダウンLEDチップなどによりマウント・リードと接着させると共に電氣的に接続させるためにはAgペースト、カーボンペースト、金属バンプ等を用いることができる。

【0036】

さらに、発光ダイオードの光利用効率を向上させるためにLEDチップ302が配置されるマウント・リードの表面を鏡面状とし、表面に反射機能を持たせても良い。この場合の表面粗さは、 0.1 S 以上 0.8 S 以下が好ましい。また、

マウント・リードの具体的な電気抵抗としては $300\ \mu\Omega\text{-cm}$ 以下が好ましく、より好ましくは、 $3\ \mu\Omega\text{-cm}$ 以下である。

【0037】

また、マウント・リード上に複数のLEDチップを積置する場合は、LEDチップからの発熱量が多くなるため熱伝導度がよいことが求められる。具体的には、 $0.01\ \text{cal}/\text{cm}^2/\text{cm}/^\circ\text{C}$ 以上が好ましく、より好ましくは $0.5\ \text{cal}/\text{cm}^2/\text{cm}/^\circ\text{C}$ 以上である。これらの条件を満たす材料としては、鉄、銅、鉄入り銅、錫入り銅、メタライズパターン付きセラミック等が挙げられる。

【0038】

(インナー・リード306)

インナー・リード306としては、マウント・リード305上に配置されたLEDチップと接続された導電性ワイヤーとの接続を図るものである。マウント・リード上に複数のLEDチップ302を設けた場合は、各導電性ワイヤー同士が接触しにくい構成とすることが好ましい。

【0039】

具体的には、マウント・リード305から離れるに従って、インナー・リード306のワイヤーボンディングさせる端面の面積を大きくする或いは、マウント・リードから離れるに従って端面の高さを高くさせることなどによってマウント・リードからより離れたインナー・リードと接続させる導電性ワイヤーの接触を防ぐことができる。

【0040】

また、導電性ワイヤーとの接続端面の粗さは、密着性を考慮して $1.6\ \text{S}$ 以上 $10\ \text{S}$ 以下が好ましい。インナー・リードの先端部を種々の形状に形成させるためには、あらかじめリードフレームの形状を型枠で決めて打ち抜き形成させてもよく、或いは全てのインナー・リードを形成させた後にインナー・リード上部の一部を削ることによって形成させても良い。さらには、インナー・リードを打ち抜き形成後、端面方向から加圧することにより所望の端面の面積と端面高さを同時に形成させることもできる。

【0041】

インナー・リードは、導電性ワイヤーであるボンディングワイヤー等との接続性及び電気伝導性が良いことが求められる。具体的な電気抵抗としては、 $300\ \mu\Omega\text{-cm}$ 以下が好ましく、より好ましくは $3\ \mu\Omega\text{-cm}$ 以下である。これらの条件を満たす材料としては、鉄、銅、鉄入り銅、錫入り銅及び銅、金、銀をメッキしたアルミニウム、鉄、銅等が挙げられる。

【0042】

(コーティング部材301)

本願発明に用いられるコーティング部材301とは、モールド部材304とは別にマウント・リード305のカップに設けられるものであり発光素子302の発光を変換するフォトルミネセンス蛍光体が含有されるものである。コーティング部の具体的材料としては、エポキシ樹脂、ユリア樹脂、シリコンやアクリル樹脂などの耐候性に優れた透明樹脂やケイ化物である酸化珪素、酸化アルミなどの無機物質などが好適に用いられる。また、フォトルミネセンス蛍光体と共に拡散剤を含有させても良い。具体的な拡散剤としては、チタン酸バリウム、酸化チタン、酸化アルミニウム、酸化珪素等が好適に用いられる。さらに、光安定化剤として紫外線吸収剤を含有させても良い。

【0043】

(モールド部材101、210、304)

モールド部材は、発光装置の使用用途に応じてLEDチップ、導電性ワイヤー、フォトルミネセンス蛍光体が含有されたコーティング部材などを外部から保護するために設けることができる。モールド部材は、樹脂などの有機物質や硝子などの無機物質を用いて形成させることができる。モールド部材中にフォトルミネセンス蛍光体を含有させることによって視野角を増やすことができる。また、拡散剤を加えることによってLEDチップからの指向性を緩和させ視野角をさらに増やすこともできる。さらに安定発光させるために紫外線吸収剤などの光安定化剤を含有させても良い。

【0044】

更に、モールド部材を所望の形状にすることによってLEDチップからの発光を集束させたり拡散させたりするレンズ効果を持たせることができる。従って、

モールド部材は複数積層した構造でもよい。具体的には、凸レンズ形状、凹レンズ形状さらには、発光観測面から見て楕円形状やそれらを複数組み合わせたものが挙げられる。

【0045】

モールド部材の具体的材料としては、主としてエポキシ樹脂、ユリア樹脂、シリコン、アクリル樹脂などの耐候性に優れた透明樹脂や低融点硝子などが好適に用いられる。また、拡散剤としては、チタン酸バリウム、酸化チタン、酸化アルミニウム、酸化珪素等が好適に用いられる。フォトルミネセンス蛍光体はモールド部材中に含有させてもそれ以外のコーティング部などに含有させて用いてもよい。また、コーティング部をフォトルミネセンス蛍光体が含有された樹脂、モールド部材を硝子などとした異なる部材を用いて形成させても良い。この場合、生産性良くより水分などの影響が少ない発光ダイオードとすることができる。屈折率を考慮してモールド部材とコーティング部とを同じ部材を用いて形成させても良い。

【0046】

(面状光源)

本願発明の発光装置の一つである面状光源の場合、図2(A)の如く白色光を発光させるためには白色光を導光板によって面状とさせ方法と、図2(B)の如く面状に発光したLEDチップからの青色系光を白色光に変換させる方法がある。

【0047】

白色光を導光板によって面状とさせる場合には、フォトルミネセンス蛍光体が含有された色変換部材201を介して青色系が発光可能な発光ダイオード202と、導光板204と、を配置させた構成、或いはモールド部材中210などにフォトルミネセンス蛍光体を含有させ青色系が発光可能な窒化物半導体発光素子を有する発光ダイオード202と導光板204を光学的に接続させた構成をとることができる。

【0048】

面状に発光したLEDチップ202からの青色系光を白色光に変換させる場合

は、窒化物半導体を発光層に有する青色系が発光可能な発光ダイオード202と導光板204とを光学的に接続させた後、導光板204上の散乱シート206に含有させる。或いはバインダー樹脂と共に散乱シートに塗布などさせシート状に形成させる。さらには、導光板上にフォトルミネセンス蛍光体含有のバインダーをドット状に直接形成させる構成をとることができる。

【0049】

具体的には、絶縁層及び導電性パターンが形成されたコの字形状の金属基板203内などに発光素子であるLEDチップを固定する。LEDチップと導電性パターンとの電気的導通を取った後、エポキシ樹脂をLEDチップ202が積載された基板上に充填させアクリル性導光板204の端面と光学的に接続させる。導光板204の発光主面上には、フォトルミネセンス蛍光体をエポキシ樹脂中に混合攪拌し予め拡散シート上に均一塗布したシート部材201を積置させてある。この拡散シート部材206は、アクリル樹脂をベースに拡散剤として酸化アルミニウム、酸化珪素、酸化チタン、チタン酸バリウムの粒子などを含有させたエポキシ樹脂を塗布させた層と、フォトルミネセンス蛍光体を含有させた層とに分かれている。

【0050】

導光板の一方の主面上には、発光ダイオード近傍からの光が強発光する蛍現象防止のため白色散乱剤が含有されたフィルム状の反射部材207を配置させてあることが好ましい。同様に、導光板204の裏面側全面や発光ダイオードが配置されていない端面上にも反射部材205を設け発光効率を向上させてある。これにより、液晶のバックライトなどとして使用した場合においても十分な明るさを得られる面状光源とすることができる。液晶表示装置として利用する場合は、導光板の主面上に不示図の透光性導電性パターンが形成された硝子基板間に注入された液晶を介して配された偏光板により構成させることができる。以下、本願発明の実施例について説明するが、本願発明は具体的実施例のみに限定されるものではないことは言うまでもない。

【0051】

【実施例】

(実施例1)

発光素子として発光ピークが450nmの $\text{In}_{0.05}\text{Ga}_{0.95}\text{N}$ 半導体を用いた。LEDチップは、洗浄させたサファイヤ基板上にTMG（トリメチルガリウム）ガス、TMI（トリメチルインジウム）ガス、窒素ガス及びドーパントガスをキャリアガスと共に流し、MOCVD法で窒化ガリウム系化合物半導体を成膜させることにより形成させた。ドーパントガスとして SiH_4 と Cp_2Mg と、を切り替えることによってN型導電性を有する窒化ガリウム半導体とP型導電性を有する窒化ガリウム半導体を形成しPN接合を形成させる。半導体発光素子としては、N型導電性を有する窒化ガリウム半導体であるコンタクト層、N型導電性を有する窒化ガリウムアルミニウム半導体であるクラッド層、P型導電性を有する窒化ガリウムアルミニウム半導体であるクラッド層、P型導電性を有する窒化ガリウム半導体であるコンタクト層を形成させた。N型導電性を有するクラッド層とP型導電性を有するクラッド層との間にダブルヘテロ接合となるZnドープ InGaIn の活性層を形成させた。（なお、サファイヤ基板上には、低温で窒化ガリウム半導体を形成させバッファ層とさせてある。P型半導体は、成膜後400℃以上でアニールさせてある。）

エッチングによりPN各半導体表面を露出させた後、スパッタリングにより各電極をそれぞれ形成させた。こうして出来上がった半導体ウエハーをスクライブラインを引いた後、外力により分割させ発光素子としてLEDチップを形成させた。

【0052】

銀メッキした銅製リードフレームの先端にカップを有するマウント・リードにLEDチップをエポキシ樹脂でダイボンディングした。LEDチップの各電極とマウント・リード及びインナー・リードと、をそれぞれ金線でワイヤーボンディングし電氣的導通を取った。

【0053】

モールド部材は、砲弾型の型枠の中にLEDチップが配置されたリードフレームを挿入し透光性エポキシ樹脂を混入後、150℃5時間にて硬化させ青色系発光ダイオードを形成させた。青色系発光ダイオードを端面が全て研磨されたアク

リル性導光板の一端面に接続させた。アクリル板の片面及び側面は、白色反射部材としてチタン酸バリウムをアクリル系バインダー中に分散したものでスクリーン印刷及び硬化させた。

【0054】

一方、フォトルミネセンス蛍光体は、緑色系及び赤色系をそれぞれ必要なY、Gd、Ce、Laの希土類元素を化学量論比で酸に溶解した溶解液を稀酸で共沈させた。これを焼成して得られる共沈酸化物と、酸化アルミニウム、酸化ガリウムと混合して混合原料をそれぞれ得る。これにフラックスとしてフッ化アンモニウムを混合して坩堝に詰め、空气中1400°Cの温度範囲で3時間焼成して焼成品を得た。焼成品をそれぞれ水中でボールミルして、洗浄、分離、乾燥、最後に篩を通して形成させた。

【0055】

形成された組成が $Y_3(A1_{0.6}Ga_{0.4})_5O_{12}:Ce$ であり緑色系が発光可能な第1の蛍光体120重量部と同様の工程で形成され組成が $(Y_{0.4}Gd_{0.6})_3Al_5O_{12}:Ce$ であり赤色系が発光可能な第2の蛍光体100重量部を、エポキシ樹脂100重量部とよく混合してスラリーとさせた。このスラリーを厚さ0.5mmのアクリル層上にマルチコーターを用いて均等に塗布、乾燥し、厚さ約30 μ mの色変換部材として蛍光体層を形成させた。蛍光体層を導光板の主発光面と同じ大きさに切断し導光板上に配置させることにより発光装置を形成させた。発光装置の色度点、演色性指数を測定した。それぞれ、色度点(x=0.29, y=0.34)、Ra(演色性指数)=92.0と三波長型蛍光灯に近い性能を示した。また、発光効率は12lm/wと白色電球並であった。さらに耐侯試験として室温60mA通電、室温20mA通電、60°C90%RH下で20mA通電の各試験においても蛍光体に起因する変化は観測されなかった。

【0056】

(比較例1)

第1及び第2のフォトルミネセンス蛍光体をそれぞれペリレン系誘導体である緑色有機蛍光顔料(シンロイヒ化学製FA-001)と赤色有機蛍光顔料(シンロイヒ化学製FA-005)として同量で混合攪拌した以外は、実施例1と同様

にして発光ダイオードの形成及び耐候試験を行った。形成された発光ダイオードの色度座標は、 $(X, Y) = (0.34, 0.35)$ であった。耐候性試験として、カーボンアークで紫外線量を200hrで太陽光の1年分とほぼ同等とさせ時間と共に輝度の保持率及び色調を測定した。また、信頼性試験としてLEDチップを発光させ70℃一定における時間と共に発光輝度及び色調を測定した。この結果を実施例1と共に図6及び図7にそれぞれ示す。

【0057】

(実施例2)

発光素子は、実施例1と同様にして発光ピークが450nmの $\text{In}_{0.05}\text{Ga}_{0.95}\text{N}$ の発光層を有するLEDチップを形成させた。銀メッキした銅製リードフレームの先端にカップを有するマウント・リードにLEDチップをエポキシ樹脂でダイボンディングした。LEDチップの各電極とマウント・リード及びインナー・リードと、をそれぞれ金線でワイヤーボンディングし電気的導通を取った。

【0058】

一方、フォトルミネセンス蛍光体は、緑色系及び赤色系をそれぞれ必要なY、Gd、Ceの希土類元素を化学量論比で酸に溶解した溶解液を蔭酸で共沈させた。これを焼成して得られる共沈酸化物と、酸化アルミニウム、酸化ガリウムと混合して混合原料をそれぞれ得る。これにフラックスとしてフッ化アンモニウムを混合して坩堝に詰め、空气中1400℃の温度範囲で3時間焼成してそれぞれ焼成品を得た。焼成品を水中でボールミルして、洗浄、分離、乾燥、最後に篩を通して形成させた。

【0059】

形成された組成が $\text{Y}_3(\text{Al}_{0.5}\text{Ga}_{0.5})_5\text{O}_{12}:\text{Ce}$ であり緑色系が発光可能な第1の蛍光体と $(\text{Y}_{0.2}\text{Gd}_{0.8})_3\text{Al}_5\text{O}_{12}:\text{Ce}$ であり赤色系が発光可能な第2の蛍光体をそれぞれ40重量部、エポキシ樹脂100重量部をよく混合してスリラーとさせた。このスリラーをLEDチップが配置されたマウント・リード上のカップ内に注入させた。注入後、フォトルミネセンス蛍光体が含有された樹脂を130℃1時間で硬化させた。こうしてLEDチップ上に厚さ120μのフォトルミネセンス蛍光体が含有されたコーティング部材が形成された。なお、コ

ーティング部材には、LEDチップに向かってフォトルミネセンス蛍光体が徐々に多くしてある。その後、さらにLEDチップやフォトルミネセンス蛍光体を外部応力、水分及び塵芥などから保護する目的でモールド部材として透光性エポキシ樹脂を形成させた。モールド部材は、砲弾型の型枠の中にフォトルミネセンス蛍光体のコーティング部が形成されたリードフレームを挿入し透光性エポキシ樹脂を混入後、150℃5時間にて硬化させた。こうして形成された発光ダイオードは、発光観測正面から視認するとフォトルミネセンス蛍光体のボディーカラーにより中央部が黄色っぽく着色していた。

【0060】

こうして得られた白色系が発光可能な発光ダイオードの色度点、色温度、演色性指数を測定した。それぞれ、色度点 ($x=0.32$, $y=0.34$)、Ra (演色性指数) = 89.0、発光効率は10 lm/wであった。さらに耐侯試験として室温60 mA通電、室温20 mA通電、60℃90%RH下で20 mA通電の各試験においてもフォトルミネセンス蛍光体に起因する変化は観測されず通常の青色系発光ダイオードと寿命特性に差がないことが確認できた。

【0061】

(実施例3)

発光素子として発光ピークが470 nmのIn_{0.4}Ga_{0.6}N半導体を用いた。LEDチップは、洗浄させたサファイヤ基板上にTMG (トリメチルガリウム) ガス、TMI (トリメチルインジウム) ガス、窒素ガス及びドーパントガスをキャリアガスと共に流し、MOCVD法で窒化ガリウム系化合物半導体を成膜させることにより形成させた。ドーパントガスとしてSiH₄とCp₂Mgと、を切り替えることによってN型導電性を有する窒化ガリウム半導体とP型導電性を有する窒化ガリウム半導体を形成しPN接合を形成させる。半導体発光素子としては、N型導電性を有する窒化ガリウム半導体であるコンタクト層、P型導電性を有する窒化ガリウムアルミニウム半導体であるクラッド層、P型導電性を有する窒化ガリウム半導体であるコンタクト層を形成させた。N型導電性を有するコンタクト層とP型導電性を有するクラッド層との間に厚さ約3 nmであり、単一量子井戸構造とされるノンドープInGa_{0.4}Nの活性層を形成させた。(なお、サブ

ァイア基板には、低温で窒化ガリウム半導体を形成させバッファ層とさせてある。)

エッチングによりPN各半導体表面を露出させた後、スパッタリングにより各電極をそれぞれ形成させた。こうして出来上がった半導体ウエハーをスクライブラインを引いた後、外力により分割させ発光素子としてLEDチップを形成させた。

【0062】

銀メッキした銅製リードフレームの先端にカップを有するマウント・リードにLEDチップをエポキシ樹脂でダイボンディングした。LEDチップの各電極とマウント・リード及びインナー・リードと、をそれぞれ金線でワイヤーボンディングし電氣的導通を取った。

【0063】

モールド部材は、砲弾型の型枠の中にLEDチップが配置されたリードフレームを挿入し透光性エポキシ樹脂を混入後、150℃5時間にて硬化させ青色系発光ダイオードを形成させた。青色系発光ダイオードを端面が全て研磨されたアクリル性導光板の一端面に接続させた。アクリル板の片面及び側面は、白色反射部材としてチタン酸バリウムをアクリル系バインダー中に分散したものでスクリーン印刷及び硬化させた。

【0064】

一方、フォトルミネセンス蛍光体は、組成の異なる2種類以上のセリウムで付活されたイットリウム・アルミニウム酸化物系蛍光物質として比較的短波長側の黄色系が発光可能な蛍光体と、比較的長波長側の黄色系が発光可能な蛍光体を用いた。それぞれ必要なY、Gd、Ceの希土類元素を化学量論比で酸に溶解した溶解液を酢酸で共沈させた。これを焼成して得られる共沈酸化物と、酸化アルミニウムと混合して混合原料をそれぞれ得る。これにフラックスとしてフッ化アンモニウムを混合して坩堝に詰め、空气中1400°Cの温度範囲で3時間焼成して焼成品を得た。焼成品をそれぞれ水中でボールミルして、洗浄、分離、乾燥、最後に篩を通して形成させた。

【0065】

形成された組成が $(Y_{0.8}Gd_{0.2})_3Al_5O_{12}:Ce$ であり比較的短波長側の黄色系が発光可能な蛍光体 100 重量部と同様の工程で形成され組成が $(Y_{0.4}Gd_{0.6})_3Al_5O_{12}:Ce$ であり比較的長波長側の黄色系が発光可能な蛍光体 100 重量部を、アクリル樹脂 1000 重量部とよく混合して押し出し成形させた。これにより厚さ約 $180\ \mu m$ の色変換部材として蛍光体層を形成させた。蛍光体層を導光板の主発光面と同じ大きさに切断し導光板上に配置させることにより発光装置を形成させた。発光装置の色度点、演色性指数を測定した。それぞれ、色度点 ($x=0.33, y=0.34$)、 R_a (演色性指数) = 88.0 を示した。また、発光効率は $10\ lm/w$ であった。さらに耐侯試験として室温 $60\ mA$ 通電、室温 $20\ mA$ 通電、 $60^\circ C\ 90\ \%RH$ 下で $20\ mA$ 通電の各試験においても蛍光体に起因する変化は観測されなかった。同様に、この蛍光体の含有量を種々変えることによって発光素子からの波長が変化しても所望の色度点を維持させることができる。

【0066】

【発明の効果】

高出力の窒化物系化合物半導体の発光素子と、この発光素子からの光によって励起され発光する組成の異なる 2 種類以上のフォトルミネセンス蛍光体と、を利用した本願発明の発光装置とすることにより、長時間高輝度時の使用においても発光効率が高く所望の色が発光可能な発光装置とすることができる。特に、蛍光体を励起する発光素子の発光波長が短く効率的に蛍光体が励起可能であると共に蛍光体によって等法的に放出された光は発光素子の発光層に吸収されることなく発光可能である。そのため、発光素子が反射性の部材の上に配置されるとより効率よく発光可能となる。さらに、信頼性や省電力化、小型化さらには色温度の可変性など車載や航空産業、一般電気機器に港内のブイ表示用や高速道路の標識照明など屋外での表示や照明として新たな用途を開くことができる。また、白色は人間の目で長時間視認する場合には刺激が少なく目に優しい発光ダイオードとすることができる。

【0067】

特に、本願発明の請求項 1 に記載の構成とすることにより長時間の使用におい

ても色ずれ、発光効率の低下が極めて少なく高輝度に所望の発光成分を有する白色系が発光可能な発光装置とすることができる。また、2種類以上の組成の異なる蛍光体を利用することによって演色性が高い発光装置とすることができる。さらに、発光素子の発光波長がずれたとしても蛍光体の組成や含有量を調整させることによって一定の発光色が発光可能な量産性の良い発光装置とすることができる。

【0068】

本願発明の請求項2に記載のより具体的な構成とすることにより、長時間の使用においても色ずれ、発光効率の低下が極めて少なくより所望の光が発光可能な発光装置とすることができる。

【0069】

本願発明の請求項3に記載の構成とすることにより、長時間の使用においても色ずれ、発光効率の低下が極めて少なく白色系の光を発光させることができる。

【0070】

本願発明の請求項4に記載の構成とすることにより、長時間の使用においても色ずれ、発光効率の低下が極めて少なく白色系の光を発光させることができる。

【0071】

本願発明の請求項5に記載の構成とすることにより、長時間の使用においても色ずれ、発光効率の低下が極めて少なくより所望の光が発光可能な発光装置とすることができる。

【0072】

本願発明の請求項6に記載の構成とすることにより、より効率よく長時間の使用においても色ずれ、発光効率の低下が極めて少なく発光装置とすることができる。

【0073】

本願発明の請求項7に記載の構成とすることにより、長時間の使用においても色ずれ、発光効率の低下が極めて少なく白色系の光をより均一に面状に発光させることができる。

【0074】

本願発明の請求項 8 に記載の構成とすることにより、外部環境下においても長時間の使用においても色ずれ、発光効率の低下が極めて少なく高輝度に RGB の発光成分を有する白色系が発光可能な発光ダイオードとすることができる。

【図面の簡単な説明】

【図 1】

図 1 は、本願発明の発光装置の模式的断面図である。

【図 2】

図 2 は、本願発明の他の発光装置である面状光源の模式的断面図を示し、(A) は、導光板と発光ダイオードとの間にフォトルミネセンス蛍光体を有する面状光源であり、(B) は、導光板の主面上にフォトルミネセンス蛍光体を有する面状光源である。

【図 3】

図 3 は、本願発明の他の発光装置である発光ダイオードの模式的断面図である。

【図 4】

図 4 (A) は、本願発明に用いられる第 1 及び第 2 のフォトルミネセンス蛍光体の吸収スペクトルの一例を示し、図 4 (B) は、本願発明に使用される第 1 及び第 2 のフォトルミネセンス蛍光体の発光スペクトルの一例を示した図である。

【図 5】

図 5 は、本願発明に用いられる発光素子の発光スペクトル例を示した図である。

【図 6】

図 6 は、本願発明と、比較のために示した発光装置との耐候性試験における結果を示し (A) は輝度保持率と時間との関係、(B) は色調と時間との関係を示したグラフである。

【図 7】

図 7 は、本願発明と、比較のために示した発光装置との信頼性試験における結果を示し (A) は輝度保持率と時間との関係、(B) は色調と時間との関係を示したグラフである。

【図8】

図8は、本願発明の発光装置が発光可能な色度図を表す。A及びB点は発光素子が発光する発光色を表し、C点、D点は、それぞれ2種類のフォトルミネッセンス蛍光体からの発光色を表す。

【符号の説明】

- 101、210・・・フォトルミネッセンス蛍光体が含有されたモールド部材
- 102、202、302・・・発光素子
- 103、303・・・導電性ワイヤー
- 104・・・筐体
- 105・・・外部電極
- 201・・・色変換部材
- 203・・・支持体
- 204・・・導光板
- 205、207・・・反射部材
- 206・・・散乱シート
- 301・・・フォトルミネッセンス蛍光体が含有されたコーティング部材
- 304・・・モールド部材
- 305・・・マウント・リード
- 306・・・インナー・リード

【書類名】 図面

【図1】

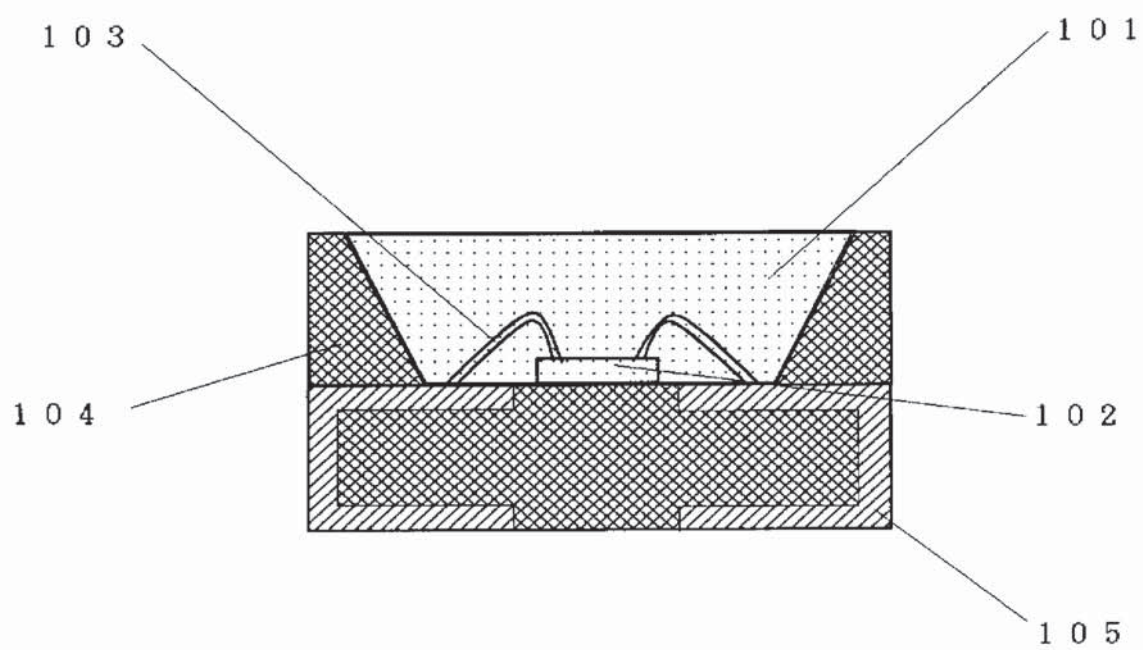

【図2】

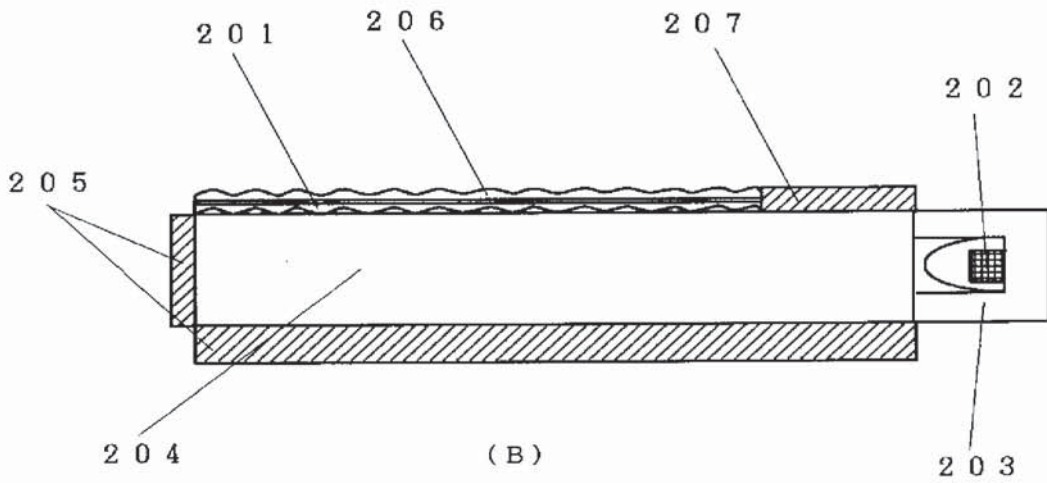
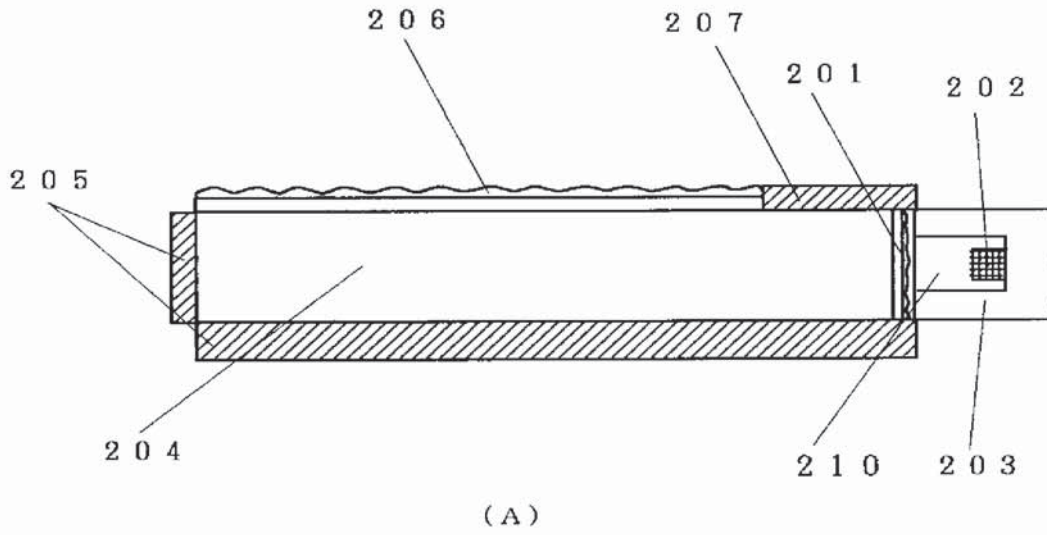

【図3】

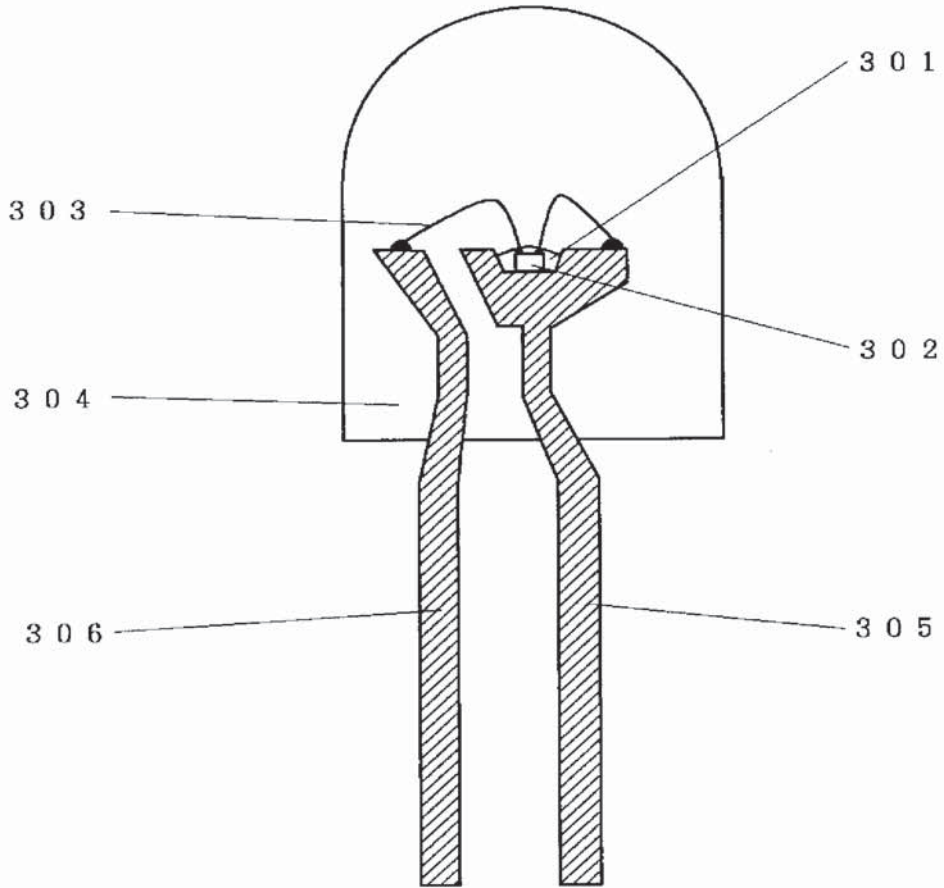

【図4】

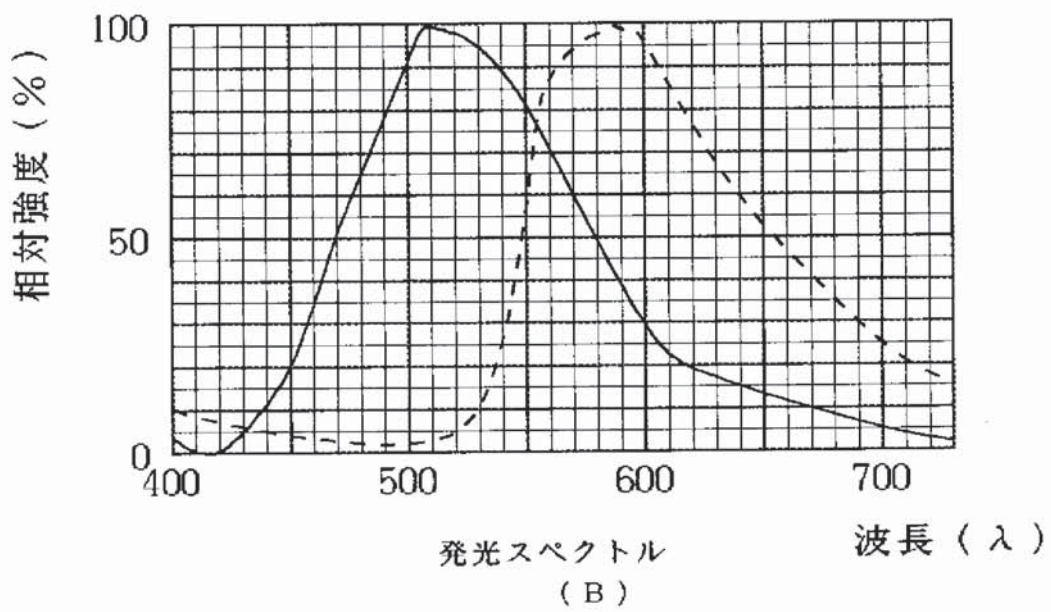
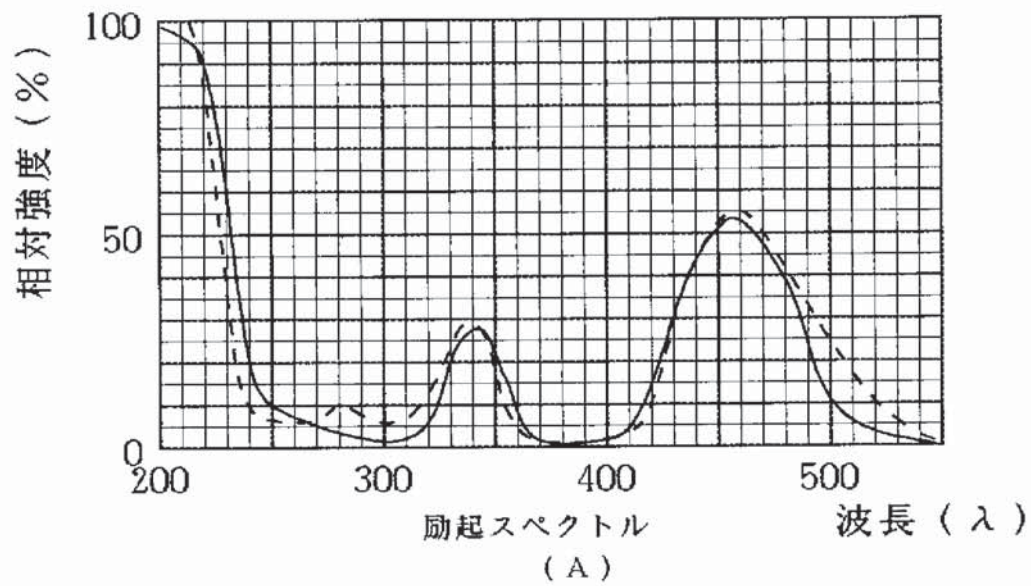

【図5】

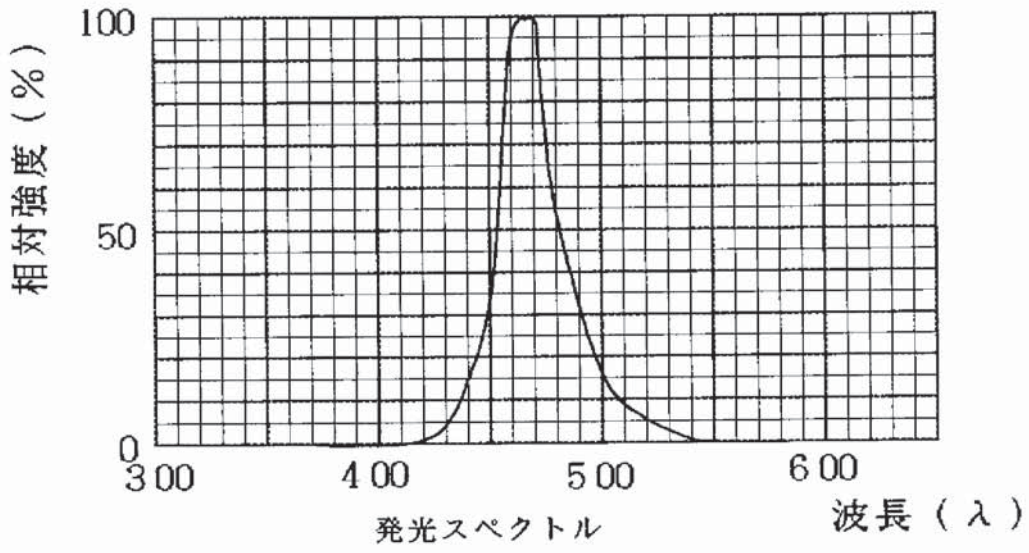

【図6】

耐候性試験

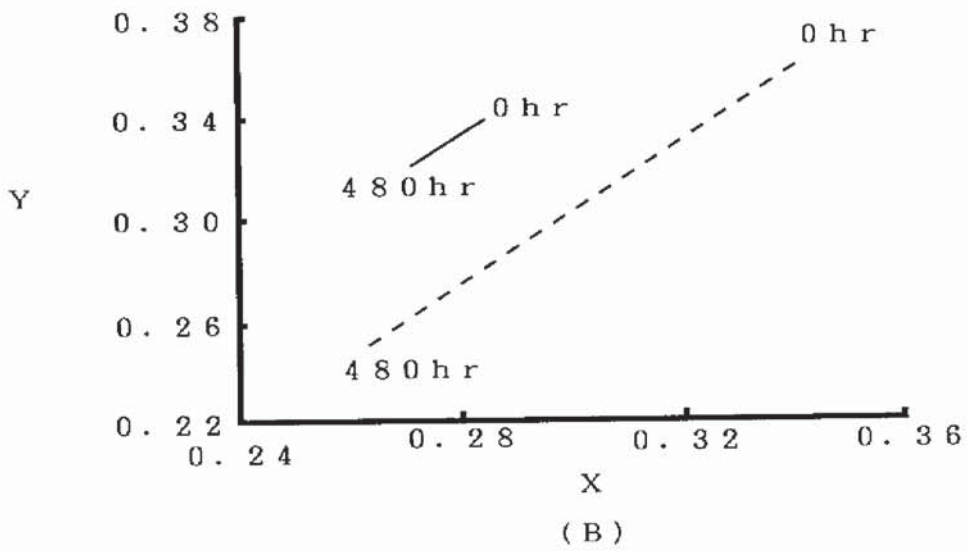
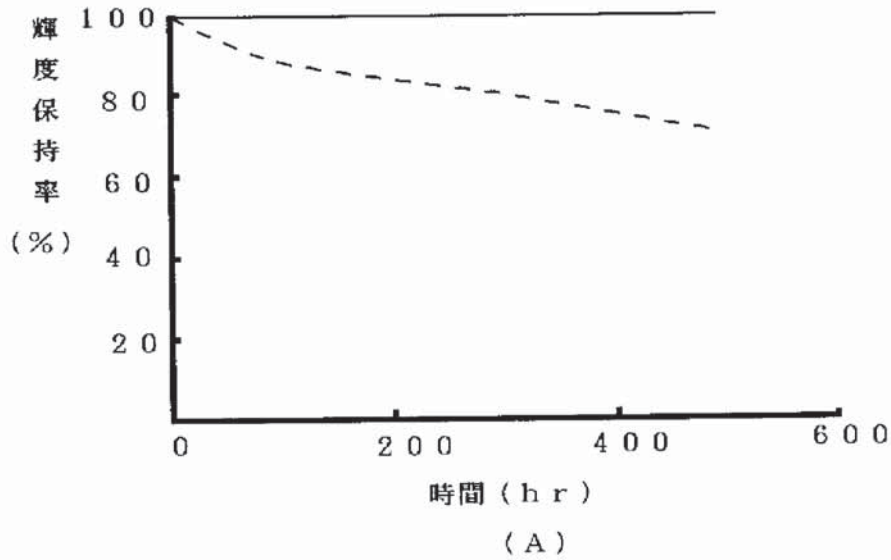

【図7】

信頼性試験

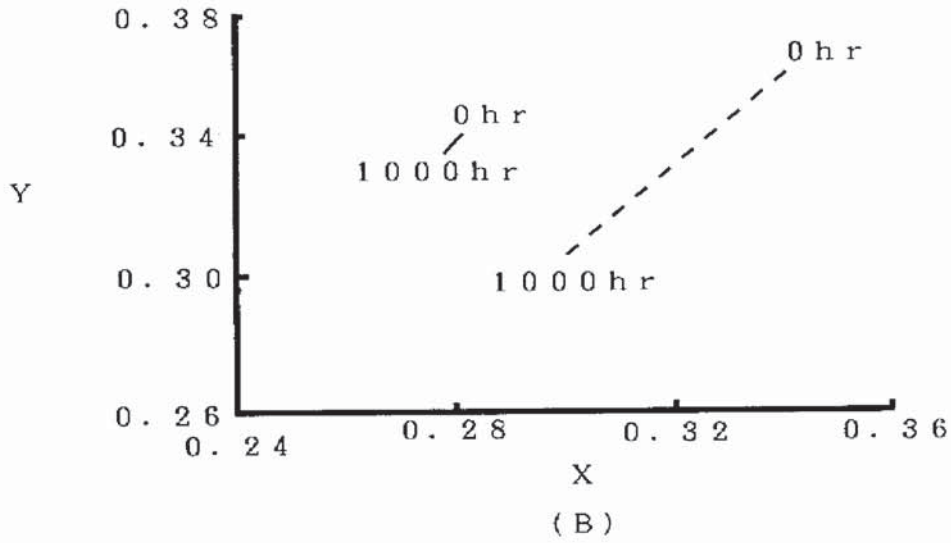
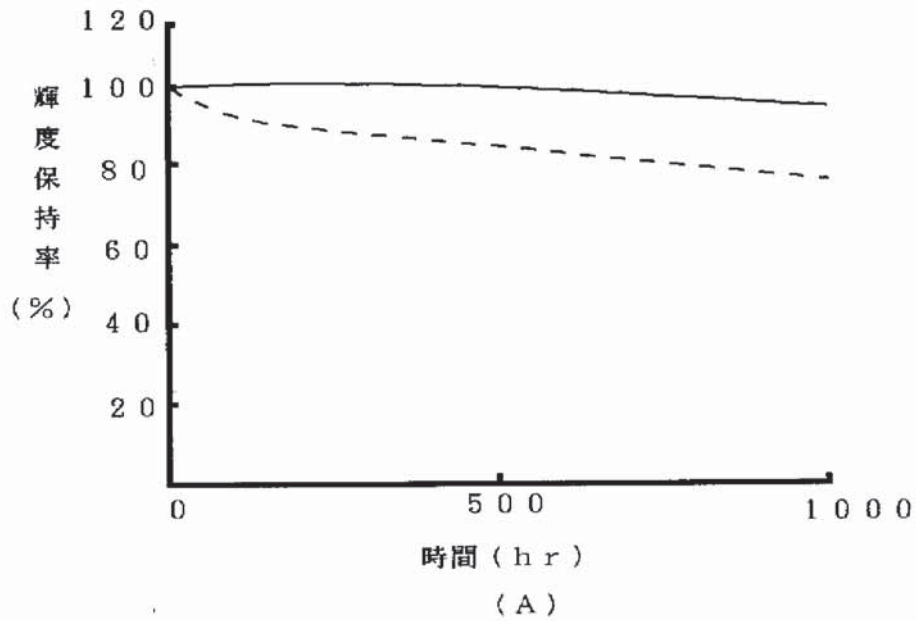

【図 8】

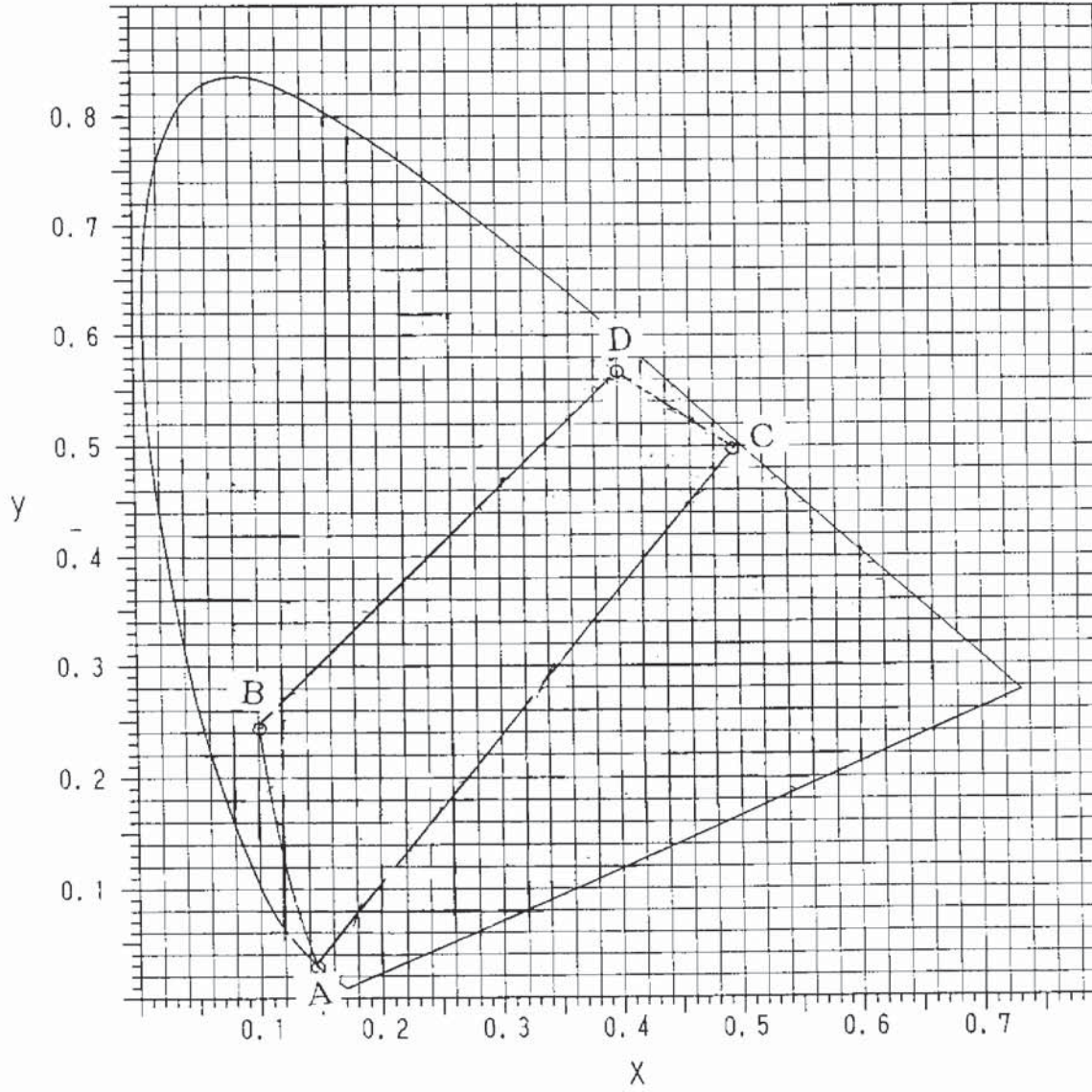

【書類名】 要約書

【要約】

【課題】

本発明は、バックライト光源、照光式スイッチ、信号機、表示器、LEDディスプレイ及び各種インジケータなどに利用される発光装置に係わり、特に使用環境によらず高輝度、高効率に所望の色に発光可能な発光装置に関する。

【解決手段】

本発明は、発光層が窒化物系化合物半導体である発光素子と、該発光素子からの発光の少なくとも一部を吸収し前記発光素子からの発光よりも長波長光を発光するフォトルミネセンス蛍光体と、を有する発光装置である。フォトルミネセンス蛍光体は、組成の異なる2種類以上のセリウムで付活されたイットリウム・アルミニウム酸化物系蛍光体である。

【選択図】 図1

【書類名】 職権訂正データ
【訂正書類】 特許願

<認定情報・付加情報>

【特許出願人】 申請人
【識別番号】 000226057
【住所又は居所】 徳島県阿南市上中町岡491番地100
【氏名又は名称】 日亜化学工業株式会社

出願人履歴

000226057

19900818

新規登録

徳島県阿南市上中町岡491番地100
日亜化学工業株式会社



UNITED STATES PATENT AND TRADEMARK OFFICE

UNITED STATES DEPARTMENT OF COMMERCE
United States Patent and Trademark Office
Address: COMMISSIONER FOR PATENTS
P.O. Box 1450
Alexandria, Virginia 22313-1450
www.uspto.gov

Table with 7 columns: APPLICATION NUMBER, FILING or 371(c) DATE, GRP ART UNIT, FIL FEE REC'D, ATTY,DOCKET.NO, TOT CLAIMS, IND CLAIMS. Row 1: 12/548,618, 08/27/2009, 2879, 1090, 0020-5147PUS5, 14, 1

CONFIRMATION NO. 7447

2292
BIRCH STEWART KOLASCH & BIRCH
PO BOX 747
FALLS CHURCH, VA 22040-0747

FILING RECEIPT



Date Mailed: 10/05/2009

Receipt is acknowledged of this non-provisional patent application. The application will be taken up for examination in due course. Applicant will be notified as to the results of the examination. Any correspondence concerning the application must include the following identification information: the U.S. APPLICATION NUMBER, FILING DATE, NAME OF APPLICANT, and TITLE OF INVENTION. Fees transmitted by check or draft are subject to collection. Please verify the accuracy of the data presented on this receipt. If an error is noted on this Filing Receipt, please submit a written request for a Filing Receipt Correction. Please provide a copy of this Filing Receipt with the changes noted thereon. If you received a "Notice to File Missing Parts" for this application, please submit any corrections to this Filing Receipt with your reply to the Notice. When the USPTO processes the reply to the Notice, the USPTO will generate another Filing Receipt incorporating the requested corrections

Applicant(s)

Yoshinori SHIMIZU, Naka-gun, JAPAN;
Kensho Sakano, Anan-shi, JAPAN;
Yasunobu Noguchi, Naka-gun, JAPAN;
Toshio Moriguchi, Anan-shi, JAPAN;

Power of Attorney: None

Domestic Priority data as claimed by applicant

This application is a DIV of 12/028,062 02/08/2008
which is a DIV of 10/609,402 07/01/2003 PAT 7,362,048
which is a DIV of 09/458,024 12/10/1999 PAT 6,614,179
which is a DIV of 09/300,315 04/28/1999 PAT 6,069,440
which is a DIV of 08/902,725 07/29/1997 PAT 5,998,925

Foreign Applications

JAPAN P 08-198585 07/29/1996
JAPAN P 08-244339 09/17/1996
JAPAN P 08-245381 09/18/1996
JAPAN P 08-359004 12/27/1996
JAPAN P 09-081010 03/31/1997

Request to Retrieve - This application either claims priority to one or more applications filed in an intellectual property Office that participates in the Priority Document Exchange (PDX) program or contains a proper Request to

Retrieve Electronic Priority Application(s) (PTO/SB/38 or its equivalent). Consequently, the USPTO will attempt to electronically retrieve these priority documents.

If Required, Foreign Filing License Granted: 09/29/2009

The country code and number of your priority application, to be used for filing abroad under the Paris Convention, is **US 12/548,618**

Projected Publication Date: 01/14/2010

Non-Publication Request: No

Early Publication Request: No
Title

LIGHT EMITTING DEVICE AND DISPLAY

Preliminary Class

313

PROTECTING YOUR INVENTION OUTSIDE THE UNITED STATES

Since the rights granted by a U.S. patent extend only throughout the territory of the United States and have no effect in a foreign country, an inventor who wishes patent protection in another country must apply for a patent in a specific country or in regional patent offices. Applicants may wish to consider the filing of an international application under the Patent Cooperation Treaty (PCT). An international (PCT) application generally has the same effect as a regular national patent application in each PCT-member country. The PCT process **simplifies** the filing of patent applications on the same invention in member countries, but **does not result** in a grant of "an international patent" and does not eliminate the need of applicants to file additional documents and fees in countries where patent protection is desired.

Almost every country has its own patent law, and a person desiring a patent in a particular country must make an application for patent in that country in accordance with its particular laws. Since the laws of many countries differ in various respects from the patent law of the United States, applicants are advised to seek guidance from specific foreign countries to ensure that patent rights are not lost prematurely.

Applicants also are advised that in the case of inventions made in the United States, the Director of the USPTO must issue a license before applicants can apply for a patent in a foreign country. The filing of a U.S. patent application serves as a request for a foreign filing license. The application's filing receipt contains further information and guidance as to the status of applicant's license for foreign filing.

Applicants may wish to consult the USPTO booklet, "General Information Concerning Patents" (specifically, the section entitled "Treaties and Foreign Patents") for more information on timeframes and deadlines for filing foreign patent applications. The guide is available either by contacting the USPTO Contact Center at 800-786-9199, or it can be viewed on the USPTO website at <http://www.uspto.gov/web/offices/pac/doc/general/index.html>.

For information on preventing theft of your intellectual property (patents, trademarks and copyrights), you may wish to consult the U.S. Government website, <http://www.stopfakes.gov>. Part of a Department of Commerce initiative, this website includes self-help "toolkits" giving innovators guidance on how to protect intellectual property in specific countries such as China, Korea and Mexico. For questions regarding patent enforcement issues, applicants may call the U.S. Government hotline at 1-866-999-HALT (1-866-999-4158).

LICENSE FOR FOREIGN FILING UNDER
Title 35, United States Code, Section 184
Title 37, Code of Federal Regulations, 5.11 & 5.15

GRANTED

The applicant has been granted a license under 35 U.S.C. 184, if the phrase "IF REQUIRED, FOREIGN FILING LICENSE GRANTED" followed by a date appears on this form. Such licenses are issued in all applications where the conditions for issuance of a license have been met, regardless of whether or not a license may be required as set forth in 37 CFR 5.15. The scope and limitations of this license are set forth in 37 CFR 5.15(a) unless an earlier license has been issued under 37 CFR 5.15(b). The license is subject to revocation upon written notification. The date indicated is the effective date of the license, unless an earlier license of similar scope has been granted under 37 CFR 5.13 or 5.14.

This license is to be retained by the licensee and may be used at any time on or after the effective date thereof unless it is revoked. This license is automatically transferred to any related applications(s) filed under 37 CFR 1.53(d). This license is not retroactive.

The grant of a license does not in any way lessen the responsibility of a licensee for the security of the subject matter as imposed by any Government contract or the provisions of existing laws relating to espionage and the national security or the export of technical data. Licensees should apprise themselves of current regulations especially with respect to certain countries, of other agencies, particularly the Office of Defense Trade Controls, Department of State (with respect to Arms, Munitions and Implements of War (22 CFR 121-128)); the Bureau of Industry and Security, Department of Commerce (15 CFR parts 730-774); the Office of Foreign Assets Control, Department of Treasury (31 CFR Parts 500+) and the Department of Energy.

NOT GRANTED

No license under 35 U.S.C. 184 has been granted at this time, if the phrase "IF REQUIRED, FOREIGN FILING LICENSE GRANTED" DOES NOT appear on this form. Applicant may still petition for a license under 37 CFR 5.12, if a license is desired before the expiration of 6 months from the filing date of the application. If 6 months has lapsed from the filing date of this application and the licensee has not received any indication of a secrecy order under 35 U.S.C. 181, the licensee may foreign file the application pursuant to 37 CFR 5.15(b).



UNITED STATES PATENT AND TRADEMARK OFFICE

UNITED STATES DEPARTMENT OF COMMERCE
United States Patent and Trademark Office
Address: COMMISSIONER FOR PATENTS
P.O. Box 1450
Alexandria, Virginia 22313-1450
www.uspto.gov

APPLICATION NUMBER	FILING OR 371(C) DATE	FIRST NAMED APPLICANT	ATTY. DOCKET NO./TITLE
12/548,618	08/27/2009	Yoshinori SHIMIZU	0020-5147PUS5

CONFIRMATION NO. 7447

IMPROPER CPOA LETTER

2292
BIRCH STEWART KOLASCH & BIRCH
PO BOX 747
FALLS CHURCH, VA 22040-0747



Date Mailed: 10/05/2009

NOTICE REGARDING POWER OF ATTORNEY

This is in response to the Power of Attorney filed 08/27/2009. The Power of Attorney in this application is not accepted for the reason(s) listed below:

- The Power of Attorney you provided did not comply with the new Power of Attorney rules that became effective on June 25, 2004. See 37 CFR 1.32.

/bpham/

Office of Data Management, Application Assistance Unit (571) 272-4000, or (571) 272-4200, or 1-888-786-0101

Under the Paperwork Reduction Act of 1995, no persons are required to respond to a collection of information unless it displays a valid OMB control number.

UTILITY PATENT APPLICATION TRANSMITTAL <small>(ONLY FOR NEW NONPROVISIONAL APPLICATIONS UNDER 37 CFR 1.53(B))</small>		Attorney Docket No.	0020-5147PUS5	
		First Inventor	Yoshinori SHIMIZU	
		Title	LIGHT EMITTING DEVICE AND DISPLAY	
		Express Mail Label No.		

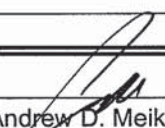
APPLICATION ELEMENTS <small>See MPEP chapter 600 concerning utility patent application contents.</small>		ADDRESS TO: Commissioner for Patents P.O. Box 1450 Alexandria, VA 22313-1450	
1. <input checked="" type="checkbox"/> Fee Transmittal Form (e.g., PTO/SB/17) 2. <input type="checkbox"/> Applicant claims small entity status. <small>See 37 CFR 1.27.</small> 3. <input checked="" type="checkbox"/> Specification [Total Pages <u>60</u>] <small>Both the claims and abstract must start on a new page (For information on the preferred arrangement, see MPEP 608.01(a))</small> 4. <input checked="" type="checkbox"/> Drawing(s) (35 U.S.C. 113) [Total Sheets <u>19</u>] 5. Oath or Declaration [Total Sheets <u>2</u>] a. <input type="checkbox"/> Newly executed (original or copy) b. <input checked="" type="checkbox"/> A copy from a prior application (37 CFR 1.63(d)) <small>(for continuation/divisional with Box 18 completed)</small> i. <input type="checkbox"/> DELETION OF INVENTOR(S) Signed statement attached deleting inventor(s) name in the prior application, see 37 CFR 1.63(d)(2) and 1.33(b). 6. <input type="checkbox"/> Application Data Sheet. See 37 CFR 1.76 7. <input type="checkbox"/> CD-ROM or CD-R in duplicate, large table or Computer Program (Appendix) <input type="checkbox"/> Landscape Table on CD 8. Nucleotide and/or Amino Acid Sequence Submission <small>(if applicable, items a. - c. are required)</small> a. <input type="checkbox"/> Computer Readable Form (CRF) b. Specification Sequence Listing on: i. <input type="checkbox"/> CD-ROM or CD-R (2 copies); or ii. <input type="checkbox"/> Paper c. <input type="checkbox"/> Statements verifying identity of above copies		ACCOMPANYING APPLICATION PARTS 9. <input type="checkbox"/> Assignment Papers (cover sheet & document(s)) Name of Assignee <input type="text"/> 10. <input type="checkbox"/> 37 CFR 3.73(b) Statement <input type="checkbox"/> Power of Attorney <small>(when there is an assignee)</small> 11. <input type="checkbox"/> English Translation Document (if applicable) 12. <input checked="" type="checkbox"/> Information Disclosure Statement (PTO/SB/08 or PTO-1449) <input type="checkbox"/> Copies of citations attached 13. <input type="checkbox"/> Preliminary Amendment 14. <input type="checkbox"/> Return Receipt Postcard (MPEP 503) <small>(Should be specifically itemized)</small> 15. <input type="checkbox"/> Certified Copy of Priority Document(s) <small>(if foreign priority is claimed)</small> 16. <input type="checkbox"/> Nonpublication Request under 35 U.S.C.122 (b)(2)(B)(i). Applicant must attach form PTO/SB/35 or equivalent. 17. <input checked="" type="checkbox"/> Other: <input type="text"/> Copy of letter submitting priority documents	
18. If a CONTINUING APPLICATION, check appropriate box, and supply the requisite information below and in the first sentence of the specification following the title, or in an Application Data Sheet under 37 CFR 1.76: <input type="checkbox"/> Continuation <input checked="" type="checkbox"/> Divisional <input type="checkbox"/> Continuation-in-part (CIP) of prior application No.: <u>12/028,062</u> Prior application information: Examiner <u>Abdulfattah B. Mustapha</u> Art Unit: <u>2812</u>			
19. CORRESPONDENCE ADDRESS			
<input checked="" type="checkbox"/> The address associated with Customer Number: <input type="text"/> <u>02292</u> OR <input type="checkbox"/> Correspondence address below			
Name			
Address			
City		State	Zip Code
Country	Telephone	Email	
Signature		Date	
Name (Print/Type)		Registration No. (Attorney/Agent)	
 Andrew D. Meikle		AUG 27 2009 32,868	

IN THE UNITED STATES PATENT AND TRADEMARK OFFICE

In re Patent Application of:
Yoshinori SHIMIZU et al.

Application No.: NEW

Confirmation No.: N/A

Filed: AUG 27 2009

Art Unit: N/A

For: LIGHT EMITTING DEVICE AND DISPLAY

Examiner: Not Yet Assigned

INFORMATION DISCLOSURE STATEMENT
(SUBMISSION WITH DIVISIONAL APPLICATION)

Commissioner for Patents
P.O. Box 1450
Alexandria, VA 22313-1450

Sir:

Pursuant to 37 C.F.R. §§ 1.97 and 1.98, applicant(s) hereby submit(s) an Information Disclosure Statement for consideration by the Examiner.

I. LIST OF PATENTS, PUBLICATIONS OR OTHER INFORMATION

The patents, publications, or other information submitted for consideration by the Office are listed on the PTO-SB08(s), attached hereto.

II. COPIES

a. Copies of cited U.S. patents and patent application publications are not included. Copies of foreign patent documents and non-patent literature are included.

b. Some or all of the documents listed on the PTO-SB08 are not enclosed because they were cited in the International Search Report and copies should already be in the PTO file. If copies are needed, please contact the undersigned.

c. REFERENCES PREVIOUSLY CITED OR SUBMITTED - Pursuant to 37 C.F.R. §1.98(d), consideration of information listed on the PTO-SB08 form(s) is requested since any patents, publications, or other information which are listed on the PTO-SB08 form(s) but for which copies are not enclosed herewith, were previously cited by or submitted to the PTO in one of the following applications which has been relied upon for an earlier filing date under 35 U.S.C. § 120:

U.S. Appl. No(s) and U.S. Filing Date

12/028,062 filed February 8, 2008

III. CONCISE EXPLANATION OF THE RELEVANCE

(check at least one box)

a. DOCUMENTS IN THE ENGLISH LANGUAGE - Some or all of the patents, publications, or other information listed on the attached PTO SB08 are in the English language and therefore, do not require a statement of relevancy.

b. DOCUMENTS NOT IN THE ENGLISH LANGUAGE - A concise explanation of the relevance of all patents, publications, or other information listed that is not in the English language is as follows:

c. ENGLISH LANGUAGE SEARCH REPORT - An English language version of the search report or action that indicates the degree of relevance found by the foreign office is attached, thereby satisfying the requirement for a concise explanation. See MPEP 609(III)(A)(3).

d. OTHER - The following additional information is provided for the Examiner's consideration. All references were cited during prosecution of parent Application No. 12/028,062 filed February 8, 2008.

IV. FEES (check one box)

a. This Information Disclosure Statement is being filed concurrently with the filing of a new patent application; therefore, no fee is required.

b. This Information Disclosure Statement is being filed concurrent with the filing of a continuation-in-part, continuation, or divisional patent application; therefore, no fee is required.

c. This Information Disclosure Statement is being filed within three months of the filing date of a national application (37 C.F.R. § 1.97(b)(1)). No fee or statement is required.

d. This Information Disclosure Statement is being filed within three months of the date of entry of the national stage as set forth in § 1.491 in an international application (37 C.F.R. § 1.97(b)(2)). No fee or statement is required.

e. This Information Disclosure Statement is being filed concurrently with the filing of a Request for Continued Examination under § 1.114 (37 C.F.R. § 1.97(b)(4)). No fee or statement is required.

f. This Information Disclosure Statement is being filed before the mailing date of a first Action on the merits (37 C.F.R. § 1.97(b)(3)). No fee or statement is required. In the event that a first Office Action on the merits has been issued, please consider this IDS under 37 C.F.R. § 1.97(c) and see the statement under 37 C.F.R. § 1.97(e) below, or, if no statement has been made, charge our deposit account for the fee as required by 37 C.F.R. § 1.17(p).

g. This Information Disclosure Statement is being filed before the mailing date of a Final Office Action under 37 C.F.R. § 1.113 (See 37 C.F.R. § 1.97(c)(1)) or before the mailing date of a Notice of Allowance under 37 C.F.R. § 1.311 (See 37 C.F.R. § 1.97(c)(2)).

No statement; therefore, a fee as required by 37 C.F.R. § 1.17(p) is attached.

or

See the statement below. No fee is required.

V. STATEMENT UNDER 37 C.F.R. § 1.97(e)

(check only one box)

The undersigned hereby states that:

a. Each item of information contained in the IDS was first cited in any communication from a foreign Patent Office in a counterpart foreign application not more than 30 days prior to the filing of this IDS; or

b. Each item of information contained in the IDS was first cited in any communication from a foreign Patent Office in a counterpart foreign application not more than three months prior to the filing of this IDS; or

c. No item of information contained in the IDS was cited in a communication from a foreign Patent Office in a counterpart foreign application, and, to the knowledge of the person signing the certification after making reasonable inquiry, no item of IDS was known to any individual designated in 37 C.F.R. § 1.56(c) more than three months prior to the filing of the IDS.

d. Some of the items of information were cited in a communication from a foreign Patent Office. As to this information, the undersigned states that each item of information contained in the IDS was first cited in a communication from a foreign Patent Office in a counterpart foreign application not more than three months prior to the filing of this IDS. As to the remaining information, the undersigned hereby states that no item of this remaining information contained in the IDS was cited in a communication from a foreign Patent Office in a counterpart foreign application and, to the best of my knowledge after making reasonable inquiry, was known to any individual designated in 37 C.F.R. § 1.56(c) more than three months prior to the filing of this statement.

VI. PAYMENT OF FEES (check one box)

The required fee is listed on the attached Fee Transmittal.

No fee is required.

If the Examiner has any questions concerning this IDS, he/she is requested to contact the undersigned. If it is determined that this IDS has been filed under the wrong rule, the PTO is

Application No.:

Docket No.: 0020-5147PUS5

requested to consider this IDS under the proper rule and charge the appropriate fee to Deposit Account No. 02-2448.

If necessary, the Commissioner is hereby authorized in this, concurrent, and future replies, to charge payment or credit any overpayment to our Deposit Account No. 02-2448 for any additional fees required under 37 C.F.R. § 1.16 or under § 1.17; particularly, extension of time fees.

Dated: AUG 27 2009

Respectfully submitted,

By 
Andrew D. Meikle
Registration No.: 32,868
BIRCH, STEWART, KOLASCH & BIRCH, LLP
8110 Gatehouse Road, Suite 100 East
P.O. Box 747
Falls Church, Virginia 22040-0747
(703) 205-8000
Attorney for Applicant

Attachment(s):

- PTO/SB/08
- Document(s)
- Foreign Search Report(s)
- Fee
- Other:

Substitute for form 1449/PTO INFORMATION DISCLOSURE STATEMENT BY APPLICANT (Use as many sheets as necessary)			<i>Complete if Known</i>	
			Application Number	NEW
Sheet 1 of 5			Filing Date	AUG 27 2009
			First Named Inventor	Yoshinori SHIMIZU
			Art Unit	N/A
			Examiner Name	Not Yet Assigned
			Attorney Docket Number	0020-5147PUS5

U.S. PATENT DOCUMENTS						
Examiner Initials*	Cite No. ¹	Document Number		Publication Date MM-DD-YYYY	Name of Patentee or Applicant of Cited Document	Pages, Columns, Lines, Where Relevant Passages or Relevant Figures Appear
		Number-Kind Code ² (if known)				
	AA*	US-5,700,713-A		12-23-1997	Yamazaki et al.	
	AB*	US-5,257,049		10-26-1993	Van Peteghem	
	AC*	US-6,812,500		11-02-2004	Reeh et al.	
	AD*	US-2001-0030326-A1		10-18-2001	Reeh et al.	
	AE*	US-6,576,930		06-10-2003	Reeh et al.	
	AF*	US-6,784,511		08-31-2004	Kunihara et al.	
	AG*	US-6,066,861		05-23-2000	Hohn et al.	
	AH*	US-5,959,316		09-28-1999	Lowery	
	AI*	US-5,118,985-A		06-02-1992	Patton et al.	
	AJ*	US-4,644,223		02-17-1987	de Hair et al.	
	AK*	US-6,538,371		03-25-2003	Duggal et al.	
	AL*	US-3,875,456		04-01-1975	Kano et al.	
	AM*	US-3,510,732		05-05-1970	R.L. Amans	
	AN*	US-5,550,657		08-27-1996	Tanaka et al.	
	AO*	US-5,578,839		11-26-1996	Nakamura et al.	
	AP*	US-6,004,001-A		12-21-1999	Noll	
	AQ*	US-4,905,060		02-27-1990	Chinone et al.	
	AR*	US-3,652,956		03-28-1972	Pinnow et al.	
	AS*	US-4,314,910		02-09-1982	Barnes	
	AT*	US-5,006,908		04-09-1991	Matsuoka et al.	
	AU*	US-5,369,289		11-29-1994	Tamaki et al.	
	AV*	US-4,727,283		02-23-1988	van Kemenade et al.	
	AW*	US-4,298,820		11-03-1981	Bongers et al.	
	AX*	US-3,699,478		10-17-1972	Pinnow et al.	
	AY*	US-6,798,537		08-25-1998	Nitta	
	AZ*	US-5,202,777		04-13-1993	Sluzky et al.	
	AA1*	US-3,819,974		06-25-1974	Stevenson et al.	
	AB1*	US-5,847,507		12-08-1998	Butterworth et al.	
	AC1*	US-3,691,482		09-12-1972	Pinnow et al.	
	AD1*	US-4,550,256		10-29-1985	Berkstesser et al.	
	AE1*	US-4,716,337		12-29-1987	Huiskes et al.	
	AF1*	US-5,471,113		11-28-1995	De Backer et al.	
	AG1*	US-5,825,125-A		10-20-1998	Lighthart et al.	
	AH1*	US-5,602,418-A		02-11-1997	Imai et al.	
	AI1*	US-6,340,824-B1		01-22-2002	Komoto et al.	
	AJ1*	US-5,949,182		09-07-1999	Shealy et al.	
	AK1*	US-3,748,548		07-24-1973	Haisty et al.	
	AL1*	US-5,512,210		04-30-1996	Sluzky et al.	
	AM1*	US-5,630,741		05-20-1997	Potter	
	AN1*	US-4,857,228		08-15-1989	Kabay et al.	

FOREIGN PATENT DOCUMENTS							
Examiner Initials*	Cite No. ¹	Foreign Patent Document		Publication Date MM-DD-YYYY	Name of Patentee or Applicant of Cited Document	Pages, Columns, Lines, Where Relevant Passages Or Relevant Figures Appear	† ³
		Country Code ² -Number ⁴ -Kind Code ⁵ (if known)					
	BA	JP-2002-270020-A		09-20-2002	CASIO COMPUTER CO LTD		

AUG 27 2009

Used in Lieu of PTO/SB/08A/B
(Based on PTO 01-08 version)

Substitute for form 1449/PTO			<i>Complete if Known</i>	
			Application Number	NEW
INFORMATION DISCLOSURE STATEMENT BY APPLICANT <i>(Use as many sheets as necessary)</i>			Filing Date	AUG 27 2009
			First Named Inventor	Yoshinori SHIMIZU
			Art Unit	N/A
			Examiner Name	Not Yet Assigned
			Attorney Docket Number	0020-5147PUS5
Sheet	2	of	5	

	BB	JP-7-321407	12-08-1995	FUJI ELECTRIC CO LTD.	
	BC	JP-6-115158	04-26-1994	AGFA GEVAERT NV	
	BD	JP-61-158606	07-18-1986		
	BE	JP-2000-512806	09-26-2000		
	BF	JP-07-288341	10-31-1995	NICHIA CHEM IND LTD	
	BG	JP-5-226676	03-09-1993	SHARP CORP.	
	BH	JP-49-122292	11-22-1974		
	BI	JP-11-500584	01-12-1999		
	BJ	JP-8-78727-A	03-22-1996		√
	BK	JP-03-152898-A	06-28-1991		
	BL	JP-06-139973-A	05-20-1994		
	BM	EP-0 500 937-A1	09-02-1992		
	BN	JP-2001-320094-A	11-16-2001		
	BO	DE-3804293-A1	08-24-1989		
	BP	JP-06-231605-A	08-19-1994		
	BQ	GB-2 000 173	01-04-1979		
	BR	EP-0 383 215-A	08-22-1990		
	BS	DE-9013615-U	01-24-1991		
	BT	JP-59-30107-U	02-24-1984		
	BU	JP-7-32638-U	06-16-1995		
	BV	JP-01-257993-A	10-16-1989		
	BW	JP-01-260707-A	10-18-1989		
	BX	JP-02-111922-A	04-24-1990		
	BY	JP-05-142424-A	06-11-1993		
	BZ	JP-06-160635-A	06-07-1994		
	BA1	JP-06-027327-A	02-04-1994		
	BB1	JP-06-82633-A	03-25-1994		
	BC1	JP-07-114904-A	05-02-1995		
	BD1	JP-07-235207-A	09-05-1995		
	BE1	JP-53-7153	01-21-1978		
	BF1	JP-7-42152-A	07-21-1995		
	BG1	JP-55-4898-A	01-14-1980		
	BH1	JP-55-005533-A	01-16-1990		
	BI1	JP-60-185457	09-20-1985		
	BJ1	JP-62-20237-A	01-28-1987		
	BK1	JP-62-232827-A	10-13-1987		
	BL1	JP-01-189695-A	07-28-1989		
	BM1	JP-07-120754-A	05-12-1995		
	BN1	JP-06-177423-A	06-24-1994		
	BO1	JP-7-99345-A	04-11-1995		√
	BP1	JP-09-027642-A	01-28-1997		√
	BQ1	JP-05-63068-U	08-20-1993		√
	BR1	EP-0 209 942-A1	01-28-1987		√
	BS1	EP-0 541 373-A2	11-05-1992		√
	BT1	JP-0 599 224-A1	06-01-1994		√

AUG 27 2009

Used in Lieu of PTO/SB/08A/B
(Based on PTO 01-08 version)

Substitute for form 1449/PTO			<i>Complete if Known</i>	
			Application Number	NEW
INFORMATION DISCLOSURE STATEMENT BY APPLICANT (Use as many sheets as necessary)			Filing Date	AUG 27 2009
			First Named Inventor	Yoshinori SHIMIZU
			Art Unit	N/A
			Examiner Name	Not Yet Assigned
			Attorney Docket Number	0020-5147PUS5
Sheet	3	of	5	

	BU1	JP-01179471-A	07-17-1989		
	BV1	JP-5043913-C1	04-21-1975		
	BW1	JP-554898-A	01-14-1980		
	BX1	JP-09027642-A	01-28-1997		
	BY1**	JP-08007614-A	01-12-1996		
	BZ1**	JP-07176794-A	07-14-1995		
	BA2**	JP-07099345-A	04-11-1995		
	BB2**	JP-05152609	06-18-1993		√
	BC2**	JP-6220237-A	01-28-1987		√
	BD2**	WO-97/50132-A1	12-31-1997		
	BE2**	WO-98/12757-A1	03-26-1998		
	BF2**	JP-5079379	11-24-1973		
	BG2**	JP-742152	07-21-1995		√
	BH2**	JP-4717684	09-09-1972		√
	BI2**	JP-491221	01-12-1974		√
	BJ2**	JP-49112577	10-26-1974		√
	BK2**	JP-62189770	02-15-1986		√
	BL2**	JP-291980	09-29-1988		√
	BM2**	JP-5152609-A	06-18-1993		√
	BN2**	JP-5183189-A	07-23-1993		√
	BO2**	JP-863119	03-08-1996		√
	BP2**	JP-10036835-A	02-10-1998		√
	BQ2**	JP-49106283	12-27-1972		√
	BR2**	JP-5245181	10-14-1977		√
	BS2**	GB-1589964	05-20-1981		
	BT2**	JP-5441660	12-05-1979		√
	BU2**	JP-5472484	11-07-1978		√
	BV2**	JP-5950445	04-01-1984		√
	BN2**	JP-324692	03-14-1991		√
	BX2**	JP-463162	05-29-1992		√
	BY2**	JP-463163	05-29-1992		√
	BZ2**	JP-563068	08-20-1993		√
	BA3**	JP-8170077	07-02-1996		√
	BB3**	JP-5331584	03-24-1978		
	BC3**	JP-60144381	07-30-1985		√
	BD3**	JP-62167387	07-23-1987		√
	BE3**	JP-6208845	07-26-1994		√
	BF3**	JP-06177423	06-24-1994		√
	BG3**	JP-06260680	09-16-1994		√
	BH3**	JP-06268257	09-22-1994		√

Substitute for form 1449/PTO			<i>Complete if Known</i>	
			Application Number	NEW
INFORMATION DISCLOSURE STATEMENT BY APPLICANT (Use as many sheets as necessary)			Filing Date	AUG 27 2009
			First Named Inventor	Yoshinori SHIMIZU
			Art Unit	N/A
			Examiner Name	Not Yet Assigned
			Attorney Docket Number	0020-5147PUS5
Sheet	4	of	5	

	BI3**	JP-4-234481-A	08-24-1992		
	BJ3**	JP-4-80286-A	03-13-1992		
	BK3**	GB-1 305 111	01-31-1973		
	BL3**	EP-0 667 383-A2	08-16-1995		

Examiner Signature		Date Considered	
--------------------	--	-----------------	--

*EXAMINER: Initial if reference considered, whether or not citation is in conformance with MPEP 609. Draw line through citation if not in conformance and not considered. Include copy of this form with next communication to applicant. * CITE NO.: Those application(s) which are marked with a single asterisk (*) next to the Cite No. are not supplied (under 37 CFR 1.98(a)(2)(iii)) because that application was filed after June 30, 2003 or is available in the IFW. ** CITE NO.: Those document(s) which are marked with a double asterisk (**) next to the Cite No. are not supplied because they were previously cited by or submitted to the Office in a prior application relied upon in this application for an earlier filing date under 35 U.S.C. 120. ¹ Applicant's unique citation designation number (optional). ² See Kinds Codes of USPTO Patent Documents at www.uspto.gov or MPEP 901.04. ³ Enter Office that issued the document, by the two-letter code (WIPO Standard ST.3). ⁴ For Japanese patent documents, the indication of the year of the reign of the Emperor must precede the serial number of the patent document. ⁵ Kind of document by the appropriate symbols as indicated on the document under WIPO Standard ST.16 if possible. ⁶ Applicant is to place a check mark here if English language Translation is attached.

NON PATENT LITERATURE DOCUMENTS			
Examiner Initials	Cite No. ¹	Include name of the author (in CAPITAL LETTERS), title of the article (when appropriate), title of the item (book, magazine, journal, serial, symposium, catalog, etc.), date, page(s), volume-issue number(s), publisher, city and/or country where published.	T ²
	CA	"White LED lamp: Efficient light-emitting; Manufacture cost half", Nikkei Sangyo Shimbun, September 13, 1996, Published by Nihon Keizai Shimbunsha.	
	CB	"SIMENS SMT-TOPLED fur die Oberflachenmontage" Frank Mollmer et al. Simens Components, 29 (1991) Hfet 4.	
	CC	"Proceedings of the Institute of Phosphor Society", Translation of pages 1, 5 to 14 of the 264th Proceedings of the Institute of Phosphor Society, Nov. 29, 1996.	
	CD	"Nichia Chemical starts the sample shipment of white light emitting diode", News Report, translation of page 15 of Nikkei Electronics 1996.9.23 (No. 671).	
	CE	"GaNpn Contact Blue/Ultraviolet light Emitting Diode", H. Amano et al., Applied Physics, Vol. 20, No. 2, pp. 163-166 (1991)	
	CF	"Phosphors Based on Rare-Earths, A New Era in Fluorescent Lighting", B.M.J. Smets, Materials Chemistry and Physics, 16 pp. 283-299 (1987)	
	CG	"A New Phosphor for Flying-Spot Cathode-Ray Tubes for Color Television: Yellow Emitting..", G. Blasse et al., App. Phys. Lett. Vol. 11, No. 2, pp. 53-55 (1967)	
	CH	Y. Nayatani, Color Research & Application, Vol. 20, No. 3, June 1995, pp. 143-155.	
	CI	WUSTLICH MIKRO-/OPTO-ELEKTRONIK GMBH (1994/1995)	
	CJ	W.W. Holloway, Jr. et al., "Optical Properties of Cerium-Activated Garnet Crystals", 1969 Journal of the Optical Society of America, Vol. 59, No. 1, pp. 60-63	
	CK	W.W. HOLLOWAY, Jr. et al., "On The Fluorescence of Cerium - Activated Garnet Crystals", Physics Letters, Vol. 25A, No. 8, 23 October 1967, pp. 614-615.	
	CL	W.J. MINISCALCO et al., "Measurements of Excited-State Absorption in Ce ³⁺ :YAGa)", J. Appl. Phys. Vol. 49, No. 12, December 1978, pp. 6109-6111.	
	CM	Takashi MATSUOKA et al., "Growth and Properties of a Wide-Gap Semiconductor InGaN", Optoelectronics-Devices and Technologies, Vol. 5, No. 1, pp.53-64, June 1990.	
	CN	Tadao MIURA, ELECTRONICS ENGINEERING, "High-intensity White Backlighting for LCD of Car Audios", July 1996, Vol. 38, No. 7, pp. 55-58	
	CO	T. NAGATOMO et al., "Ga _{1-x} In _x N Blue Light-Emitting Diodes", Proc. Electrochem. Soc., 1993, Vol. 93-10, pp. 136-141.	

Substitute for form 1449/PTO			<i>Complete if Known</i>	
			Application Number	NEW
INFORMATION DISCLOSURE STATEMENT BY APPLICANT <i>(Use as many sheets as necessary)</i>			Filing Date	AUG 27 2009
			First Named Inventor	Yoshinori SHIMIZU
			Art Unit	N/A
			Examiner Name	Not Yet Assigned
			Attorney Docket Number	0020-5147PUS5
Sheet	5	of	5	

CP	Shuji NAKAMURA, "Zn-doped InGa _N growth and InGa _N /AlGa _N double-heterostructure blue-light-emitting diodes", <i>Journal of Crystal Growth</i> , 145 (1994), pp. 911-917.
CQ	Shuji NAKAMURA, "InGa _N /AlGa _N blue-light-emitting diodes", <i>J. Vac. Sci. Technol. A</i> 13(3), May/Jun 1995, pp.705-710.
CR	Shuji NAKAMURA, "High-Power InGa _N /AlGa _N Double-Heterostructure Blue-Light-Emitting Diodes", <i>IEDM 94 (1994)</i> , IEEE, pp. 567-570.
CS	Shuji NAKAMURA et al., "Si-Doped InGa _N Films Grown on GaN Films", <i>Jpn. J. Appl. Phys. Vol. 32 (1993)</i> , pp. L16-L19, Part 2, No. 1A/B, 15 January 1993.
CT	Shuji NAKAMURA et al., "P-GaN/N-InGa _N /N-GaN Double-Heterostructure Blue-Light-Emitting Diodes", <i>Jpn. J. Appl. Phys. Vol. 32 (1993)</i> , pp. L8-L11, Part 2, No. 1A/B, 15, January 1993.
CU	Shigeo SHIONOYA et al. (editors), "Phosphor Handbook", pp. 505-508, CRC Press, 1999.
CV	Sato et al., <i>Japanese Journal of Applied Physics</i> , Vol. 35, July 1, 1996, pp. L838-L839.
CW	S. Nakaura et al., <i>Japanese Journal of Applied Physics Part 2</i> , Vol. 31, No. 10B, 1992, pp. L1457-1459.
CX	R. W. G. Hunt, <i>Color Research & Application</i> , Vol. 16, No. 3, 1991, pp. 146-165.
CY	Proceedings of Illumination National Convention in 1983, page 12.
CZ	Phosphor Handbook, 1st Edition, 1987, pp. 233-240 and 275-277.
CA1	P. Schlouer et al. "Luminescence Conversion of Blue Light Emitting Diodes", <i>Applied Physics Letter</i> , vol. 46, p. 417-418, February 1997
CB1	Nikkei Sangyo Shin-bun of September 13, 1996.
CC1	Nakamura, <i>SPIE</i> , Vol. 3002, pp. 26-35 (1997)
CD1	Mitsubishi Electric Company Technical Report, Vol. 48, No. 9, 1974, pp. 1121-1124.
CE1	M.F. YAN et al., "Preparation of Y3Al5O12-Based Phosphor Powders, <i>J. Electrochem. Soc.</i> , Vol. 134, No. 2, Feb. 1987.
CF1	M. Ikeda, <i>Journal of the Illumination Society</i> , Vol. 71, No. 10, 1987, pp. 612-617 and English Abstract.
CG1	M. Ikeda et al., <i>Color Research & Application</i> , Vol. 16, No. 2, April 1991, pp. 72-80.
CH1	M. Ikeda et al., <i>Color Research & Application</i> , Vol. 14, No. 4, August 1989, pp. 198-206.
CI1	Kozo OSAMURA et al., "Preparation and optical properties of Ga _{1-x} In _x N thin films", <i>Journal of Applied Physics</i> , Vol. 46, No. 8, August 1975, pp. 3432-3437.
CJ1	<i>Journal of the Television Society</i> , Vol. 47, No. 5, 1993, pp. 753-764.
CK1	J.M. Robertson, et al., "Colourshift of the Ce ³⁺ Emission in Monocrystalline Epitaxially Grown Garnet Layers", 1981 <i>Philips J. Res.</i> 36, pp. 15-30
CL1	Hoffman, <i>Journal of Les</i> , pp. 89-91 (1977)
CM1	H. Shinoda et al., <i>Color Research & Application</i> , Vol. 18, No. 5, October 1993, pp. 326-333.
CN1	G. BLASSE et al., "Investigation of Some Ce ³⁺ -Activated Phosphors", <i>Journal of Chemical Physics</i> , Vol. 47, No. 12, 15 December 1967.
CO1	E.F. GIBBONS et al., "Some Factors Influencing the Luminous Decay Characteristics of Y3Al5O12:Ce ³⁺ ", <i>J. Electrochem. Soc.</i> , Vol. 120, No. 6, June 1973.
CP1	D.J. ROBBINS et al., "Lattice Defects and Energy Transfer Phenomena in Y3Al5O12:Ce ³⁺ ", pp. 1004-1013, printed June 19, 2001.
CQ1	Branko et al., Development and applications of highbright white LED lamps, November 29, 1996, The 264th Proceedings of the Institute of Phosphor Society, pages 4-16 of the English translation .

Examiner Signature	Date Considered
--------------------	-----------------

IN THE U.S. PATENT AND TRADEMARK OFFICE

Applicant(s): SHIMIZU, Yoshinori et al

COPY

Serial No.:

Group:

Filed: July 29, 1997

Examiner:

For: LIGHT EMITTING DEVICE AND DISPLAY

LETTER

Assistant Commissioner for Patents
Box Patent Application
Washington, D.C. 20231

July 29, 1997
0020-4260P

Sir:

Under the provisions of 35 USC 119 and 37 CFR 1.55(a), the applicant hereby claims the right of priority based on the following application(s):

<u>Country</u>	<u>Application No.</u>	<u>Filed</u>
JAPAN	8-198585	07/29/96
JAPAN	8-244339	09/17/96
JAPAN	8-245381	09/18/96
JAPAN	8-359004	12/27/96
JAPAN	9-081010	03/31/97

A certified copy of the above-noted application(s) is(are) attached hereto.

Please charge any fees under 37 CFR 1.16 - 1.21 (h) or credit any overpayment to Deposit Account No. 02-2448.

Respectfully submitted,

BIRCH, STEWART, KOLASCH & BIRCH, LLP

By: _____

ANDREW D. MEIKLE

Reg. No. 32,868

P. O. Box 747

Falls Church, Virginia 22040-0747

Attachment
703) 205-8000

fo

LIGHT EMITTING DEVICE AND DISPLAY

CROSS-REFERENCE TO RELATED APPLICATIONS

[0001] This application is a divisional of U.S. Application No. 12/028,062 filed February 8, 2008, which is a divisional of U.S. Application No. 10/609,402 filed July 1, 2003, now U.S. Patent 7,362,048, which is a divisional of U.S. Application No. 09/458,024, filed December 10, 1999, now U.S. Patent 6,614,179, which is a divisional of U.S. Application No. 09/300,315, filed on April 28, 1999, now U.S. Patent 6,069,440, which is a divisional of U.S. Application No. 08/902,725, filed on July 29, 1997, now U.S. Patent 5,998,925, which also claims priority on Japanese Patent Application Nos. P 08-198585 filed July 29, 1996; P 08-244339 filed September 17, 1996; P 08-245381 filed September 18, 1996; P 08-359004 filed December 27, 1996; and P 09-081010 filed March 31, 1997. The entire contents of each of these applications is hereby incorporated by reference.

BACKGROUND OF THE INVENTION

(Field of the Invention)

[0002] The present invention relates to a light emitting diode used in LED display, back light source, traffic signal, railway signal, illuminating switch, indicator, etc. More particularly, it relates to a light emitting device (LED) comprising a phosphor, which converts the wavelength of light emitted by a light emitting component and emits light, and a display device using the light emitting device.

Description of Related Art

[0003] A light emitting diode is compact and emits light of clear color with high efficiency. It is also free from such a trouble as burn-out and has good initial drive characteristic, high vibration resistance and durability to endure repetitive ON/OFF operations, because it is a semiconductor element. Thus it has been used widely in such

applications as various indicators and various light sources. Recently light emitting diodes for RGB (red, green and blue) colors having ultra-high luminance and high efficiency have been developed, and large screen LED displays using these light emitting diodes have been put into use. The LED display can be operated with less power and has such good characteristics as light weight and long life, and is therefore expected to be more widely used in the future.

[0004] Recently, various attempts have been made to make white light sources by using light emitting diodes. Because the light emitting diode has a favorable emission spectrum to generate monochromatic light, making a light source for white light requires it to arrange three light emitting components of R, G and B closely to each other while diffusing and mixing the light emitted by them. When generating white light with such an arrangement, there has been such a problem that white light of the desired tone cannot be generated due to variations in the tone, luminance and other factors of the light emitting component. Also when the light emitting components are made of different materials, electric power required for driving differs from one light emitting diode to another, making it necessary to apply different voltages different light emitting components, which leads to complex drive circuit. Moreover, because the light emitting components are semiconductor light emitting components, color tone is subject to variation due to the difference in temperature characteristics, chronological changes and operating environment, or unevenness in color may be caused due to failure in uniformly mixing the light emitted by the light emitting components. Thus light emitting diodes are effective as light emitting devices for generating individual colors, although a satisfactory light source capable of emitting white light by using light emitting components has not been obtained so far.

[0005] In order to solve these problems, the present applicant previously developed light emitting diodes which convert the color of light, which is emitted by light emitting components, by means of a fluorescent material disclosed in Japanese Patent

Kokai Nos. 5-152609, 7-99345, 7-176794 and 8-7614. The light emitting diodes disclosed in these publications are such that, by using light emitting components of one kind, are capable of generating light of white and other colors, and are constituted as follows.

[0006] The light emitting diode disclosed in the above gazettes are made by mounting a light emitting component, having a large energy band gap of light emitting layer, in a cup provided at the tip of a lead frame, and having a fluorescent material that absorbs light emitted by the light emitting component and emits light of a wavelength different from that of the absorbed light (wavelength conversion), contained in a resin mold which covers the light emitting component.

[0007] The light emitting diode disclosed as described above capable of emitting white light by mixing the light of a plurality of sources can be made by using a light emitting component capable of emitting blue light and molding the light emitting component with a resin including a fluorescent material that absorbs the light emitted by the blue light emitting diode and emits yellowish light.

[0008] However, conventional light emitting diodes have such problems as deterioration of the fluorescent material leading to color tone deviation and darkening of the fluorescent material resulting in lowered efficiency of extracting light. Darkening here refers to, in the case of using an inorganic fluorescent material such as (Cd, Zn)S fluorescent material, for example, part of metal elements constituting the fluorescent material precipitate or change their properties leading to coloration, or, in the case of using an organic fluorescent material, coloration due to breakage of double bond in the molecule. Especially when a light emitting component made of a semiconductor having a high energy band gap is used to improve the conversion efficiency of the fluorescent material (that is, energy of light emitted by the semiconductor is increased and number of photons having energies above a threshold which can be absorbed by the fluorescent material increases, resulting in more light being absorbed), or the quantity of fluorescent material consumption is decreased (that is, the fluorescent material is irradiated with relatively

higher energy), light energy absorbed by the fluorescent material inevitably increases resulting in more significant degradation of the fluorescent material. Use of the light emitting component with higher intensity of light emission for an extended period of time causes further more significant degradation of the fluorescent material.

[0009] Also the fluorescent material provided in the vicinity of the light emitting component may be exposed to a high temperature such as rising temperature of the light emitting component and heat transmitted from the external environment (for example, sunlight in case the device is used outdoors).

[0010] Further, some fluorescent materials are subject to accelerated deterioration due to combination of moisture entered from the outside or introduced during the production process, the light and heat transmitted from the light emitting component.

[0011] When it comes to an organic dye of ionic property, direct current electric field in the vicinity of the chip may cause electrophoresis, resulting in a change in the color tone.

SUMMARY OF THE INVENTION

[0012] Thus, an object of the present invention is to solve the problems described above and provide a light emitting device which experiences only extremely low degrees of deterioration in emission light intensity, light emission efficiency and color shift over a long time of use with high luminance.

[0013] The present applicant completed the present invention through researches based on the assumption that a light emitting device having a light emitting component and a fluorescent material must meet the following requirements to achieve the above-mentioned object.

[0014] The light emitting component must be capable of emitting light of high luminance with light emitting characteristic which is stable over a long time of use.

[0015] The fluorescent material being provided in the vicinity of the high-luminance light emitting component, must show excellent resistance against light and heat so that the properties thereof do not change even when used over an extended period of time while being exposed to light of high intensity emitted by the light emitting component (particularly the fluorescent material provided in the vicinity of the light emitting component is exposed to light of a radiation intensity as high as about 30 to 40 times that of sunlight according to our estimate, and is required to have more durability against light as light emitting component of higher luminance is used).

[0016] With regard to the relationship with the light emitting component, the fluorescent material must be capable of absorbing with high efficiency the light of high monochromaticity emitted by the light emitting component and emitting light of a wavelength different from that of the light emitted by the light emitting component.

[0017] Thus the present invention provides a light emitting device, comprising a light emitting component and a phosphor capable of absorbing a part of light emitted by the light emitting component and emitting light of wavelength different from that of the absorbed light;

[0018] wherein said light emitting component comprises a nitride compound semiconductor represented by the formula: $\text{In}_i\text{Ga}_j\text{Al}_k\text{N}$ where $0 \leq i$, $0 \leq j$, $0 \leq k$ and $i+j+k=1$) and said phosphor contains a garnet fluorescent material comprising at least one element selected from the group consisting of Y, Lu, Sc, La, Gd and Sm, and at least one element selected from the group consisting of Al, Ga and In, and being activated with cerium.

[0019] The nitride compound semiconductor (generally represented by chemical formula $\text{In}_i\text{Ga}_j\text{Al}_k\text{N}$ where $0 \leq i$, $0 \leq j$, $0 \leq k$ and $i+j+k=1$) mentioned above contains various materials including InGaN and GaN doped with various impurities.

[0020] The phosphor mentioned above contains various materials defined as described above, including $\text{Y}_3\text{Al}_5\text{O}_{12}:\text{Ce}$ and $\text{Gd}_3\text{In}_5\text{O}_{12}:\text{Ce}$.

[0021] Because the light emitting device of the present invention uses the light emitting component made of a nitride compound semiconductor capable of emitting light with high luminance, the light emitting device is capable of emitting light with high luminance. Also the phosphor used in the light emitting device has excellent resistance against light so that the fluorescent properties thereof experience less change even when used over an extended period of time while being exposed to light of high intensity. This makes it possible to reduce the degradation of characteristics during long period of use and reduce deterioration due to light of high intensity emitted by the light emitting component as well as extraneous light (sunlight including ultraviolet light, etc.) during outdoor use, thereby to provide a light emitting device which experiences extremely less color shift and less luminance decrease. The light emitting device of the present invention can also be used in such applications that require response speeds as high as 120 nsec., for example, because the phosphor used therein allows after glow only for a short period of time.

[0022] The phosphor used in the light emitting diode of the present invention preferably contains an yttrium-aluminum-garnet fluorescent material that contains Y and Al, which enables it to increase the luminance of the light emitting device.

[0023] In the light emitting device of the present invention, the phosphor may be a fluorescent material represented by a general formula $(\text{Re}_{1-r}\text{Sm}_r)_3(\text{Al}_{1-s}\text{Ga}_s)_5\text{O}_{12}:\text{Ce}$, where $0 \leq r < 1$ and $0 \leq s \leq 1$ and Re is at least one selected from Y and Gd, in which case good characteristics can be obtained similarly to the case where the yttrium-aluminum-garnet fluorescent material is used.

[0024] Also in the light emitting device of the present invention, it is preferable, for the purpose of reducing the temperature dependence of light emission characteristics (wavelength of emitted light, intensity of light emission, etc.), to use a fluorescent material represented by a general formula $(\text{Y}_{1-p-q-r}\text{Gd}_p\text{Ce}_q\text{Sm}_r)_3(\text{Al}_{1-s}\text{Ga}_s)_5\text{O}_{12}$ as the phosphor, where $0 \leq p \leq 0.8$, $0.003 \leq q \leq 0.2$, $0.0003 \leq r \leq 0.08$ and $0 \leq s \leq 1$.

[0025] Also in the light emitting device of the present invention, the phosphor may contain two or more yttrium-aluminum-garnet fluorescent materials, activated with cerium, of different compositions including Y and Al. With this configuration, light of desired color can be emitted by controlling the emission spectrum of the phosphor according to the property (wavelength of emitted light) of the light emitting component.

[0026] Further in the light emitting device of the present invention, in order to have light of a specified wavelength emitted by the light emitting device, it is preferable that the phosphor contains two or more fluorescent materials of different compositions represented by general formula $(\text{Re}_{1-r}\text{Sm}_r)_3(\text{Al}_{1-s}\text{Ga}_s)_5\text{O}_{12}:\text{Ce}$, where $0 \leq r < 1$ and $0 \leq s \leq 1$ and Re is at least one selected from Y and Gd.

[0027] Also in the light emitting device of the present invention, in order to control the wavelength of emitted light, the phosphor may contain a first fluorescent material represented by general formula $\text{Y}_3(\text{Al}_{1-s}\text{Ga}_s)_5\text{O}_{12}:\text{Ce}$ and a second fluorescent material represented by general formula $\text{Re}_3\text{Al}_5\text{O}_{12}:\text{Ce}$, where $0 \leq s \leq 1$ and Re is at least one selected from Y, Gd and La.

[0028] Also in the light emitting device of the present invention, in order to control the wavelength of emitted light, the phosphor may be an yttrium-aluminum-garnet fluorescent material containing a first fluorescent material and a second fluorescent material, with different parts of each yttrium being substituted with gadolinium.

[0029] Further in the light emitting device of the present invention, it is preferable that main emission peak of the light emitting component is set within the range from 400 nm to 530 nm and main emission wavelength of the phosphor is set to be longer than the main emission peak of the light emitting component. This makes it possible to efficiently emit white light.

[0030] Further in the light emitting device of the present invention, it is preferable that the light emitting layer of the light emitting component contains a gallium nitride

semiconductor which contains In, and the phosphor is an yttrium-aluminum-garnet fluorescent material wherein a part of Al in the yttrium-aluminum-garnet fluorescent is substituted by Ga so that the proportion of Ga:Al is within the range from 1:1 to 4:6 and a part of Y in the yttrium-aluminum-garnet fluorescent is substituted by Gd so that the proportion of Y:Gd is within the range from 4:1 to 2:3. Absorption spectrum of the phosphor which is controlled as described above shows good agreement with that of light emitted by the light emitting component which contains gallium nitride semiconductor including In as the light emitting layer, and is capable of improving the conversion efficiency (light emission efficiency). Also the light, generated by mixing blue light emitted by the light emitting component and fluorescent light of the fluorescent material, is a white light of good color rendering and, in this regard, an excellent light emitting device can be provided.

[0031] The light emitting device according to one embodiment of the present invention comprises a substantially rectangular optical guide plate provided with the light emitting component mounted on one side face thereof via the phosphor and surfaces of which except for one principal surface are substantially covered with a reflective material, wherein a light emitted by the light emitting component is turned into a planar light by the phosphor and the optical guide plate and to be an output from the principal surface of the optical guide plate.

[0032] The light emitting device according to another embodiment of the present invention has a substantially rectangular optical guide plate, which is provided with the light emitting component mounted on one side face thereof and the phosphor installed on one principal surface with surfaces thereof and except for the principal surface being substantially covered with a reflective material, wherein a light emitted by the light emitting component is turned into a planar light by the optical guide plate and the phosphor, to be an output from the principal surface of the optical guide plate.

[0033] The LED display device according to the present invention has an LED display device comprising the light emitting devices of the present invention arranged in a matrix and a drive circuit which drives the LED display device according to display data which is input thereto. This configuration makes it possible to provide a relatively low-priced LED display device which is capable of high-definition display with less color unevenness due to the viewing angle.

[0034] The light emitting diode according to one embodiment of the present invention comprises:

[0035] a mount lead having a cup and a lead;

[0036] an LED chip mounted in the cup of the mount lead with one of electrodes being electrically connected to the mount lead;

[0037] a transparent coating material filling the cup to cover the LED chip; and

[0038] a light emitting diode having a molding material which covers the LED chip covered with the coating material including the cup of the mount lead, the inner lead and another electrode of the LED chip, wherein

[0039] the LED chip is a nitride compound semiconductor and the coating material contains at least one element selected from the group consisting of Y, Lu, Sc, La, Gd and Sm, at least one element selected from the group consisting of Al, Ga and In and a phosphor made of garnet fluorescent material activated with cerium.

[0040] The phosphor used in the light emitting diode of the present invention preferably contains an yttrium-aluminum-garnet fluorescent material that contains Y and Al.

[0041] In the light emitting diode of the present invention, the phosphor may be a fluorescent material represented by a general formula $(\text{Re}_{1-r}\text{Sm}_r)_3(\text{Al}_{1-s}\text{Ga}_s)_5\text{O}_{12}:\text{Ce}$, where $0 \leq r < 1$ and $0 \leq s \leq 1$ and Re is at least one selected from Y and Gd.

[0042] Also in the light emitting diode of the present invention, a fluorescent material represented by a general formula $(Y_{1-p-q-r}Gd_pCe_qSm_r)_3(Al_{1-s}Ga_s)_5O_{12}$ may be used as the phosphor, where $0 \leq p \leq 0.8$, $0.003 \leq q \leq 0.2$, $0.0003 \leq r \leq 0.08$ and $0 \leq s \leq 1$.

[0043] In the light emitting diode of the present invention, the phosphor preferably contain two or more yttrium-aluminum-garnet fluorescent materials, activated with cerium, of different compositions including Y and Al, in order to control the emitted light to a desired wavelength.

[0044] In the light emitting diode of the present invention, similarly, two or more fluorescent materials of different compositions represented by a general formula $(Re_{1-r}Sm_r)_3(Al_{1-s}Ga_s)_5O_{12}:Ce$, where $0 \leq r < 1$ and $0 \leq s \leq 1$ and Re is at least one selected from Y and Gd may be used as the phosphor in order to control the emitted light to a desired wavelength.

[0045] In the light emitting diode of the present invention, similarly, a first fluorescent material represented by a general formula $Y_3(Al_{1-s}Ga_s)_5O_{12}:Ce$ and a second fluorescent material represented by a general formula $Re_3Al_5O_{12}:Ce$, may be used as the phosphor where $0 \leq s \leq 1$ and Re is at least one selected from Y, Gd and La, in order to control the emitted light to a desired wavelength.

[0046] In the light emitting diode of the present invention, similarly, yttrium-aluminum-garnet fluorescent material a first fluorescent material and a second fluorescent material may be used wherein a part of yttrium in the first and second fluorescent materials is substituted with gadolinium to different degrees of substitution as the phosphor, in order to control the emitted light to a desired wavelength.

[0047] Generally, a fluorescent material which absorbs light of a short wavelength and emits light of a long wavelength has higher efficiency than a fluorescent material which absorbs light of a long wavelength and emits light of a short wavelength. It is preferable to use a light emitting component which emits visible light than a light emitting component which emits ultraviolet light that degrades resin (molding material,

coating material, etc.). Thus for the light emitting diode of the present invention, for the purpose of improving the light emitting efficiency and ensure long life, it is preferable that main emission peak of the light emitting component be set within a relatively short wavelength range of 400 nm to 530 nm in the visible light region, and main emission wavelength of the phosphor be set to be longer than the main emission peak of the light emitting component. With this arrangement, because light converted by the fluorescent material has longer wavelength than that of light emitted by the light emitting component, it will not be absorbed by the light emitting component even when the light emitting component is irradiated with light which has been reflected and converted by the fluorescent material (since the energy of the converted light is less than the band gap energy). Thus the light which has been reflected by the fluorescent material or the like is reflected by the cup wherein the light emitting component is mounted, making higher efficiency of emission possible.

BRIEF DESCRIPTION OF THE DRAWINGS

[0048] Fig. 1 is a schematic sectional view of a lead type light emitting diode according to the embodiment of the present invention.

[0049] Fig. 2 is a schematic sectional view of a tip type light emitting diode according to the embodiment of the present invention.

[0050] Fig. 3A is a graph showing the excitation spectrum of the garnet fluorescent material activated by cerium used in the first embodiment of the present invention.

[0051] Fig. 3B is a graph showing the emission spectrum of the garnet fluorescent material activated by cerium used in the first embodiment of the present invention.

[0052] Fig. 4 is a graph showing the emission spectrum of the light emitting diode of the first embodiment of the present invention.

[0053] Fig. 5A is a graph showing the excitation spectrum of the yttrium-aluminum-garnet fluorescent material activated by cerium used in the second embodiment of the present invention.

[0054] Fig. 5B is a graph showing the emission spectrum of the yttrium-aluminum-garnet fluorescent material activated by cerium used in the second embodiment of the present invention.

[0055] Fig. 6 shows the chromaticity diagram of light emitted by the light emitting diode of the second embodiment, while

[0056] points A and B indicate the colors of light emitted by the light emitting component and points C and D indicate the colors of light emitted by two kinds of phosphors.

[0057] Fig. 7 is a schematic sectional view of the planar light source according to another embodiment of the present invention.

[0058] Fig. 8 is a schematic sectional view of another planar light source different from that of Fig. 7.

[0059] Fig. 9 is a schematic sectional view of another planar light source different from those of Fig. 7 and Fig. 8.

[0060] Fig. 10 is a block diagram of a display device which is an application of the present invention.

[0061] Fig. 11 is a plan view of the LED display device of the display device of Fig. 10.

[0062] Fig. 12 is a plan view of the LED display device wherein one pixel is constituted from four light emitting diodes including the light emitting diode of the present invention and those emitting RGB colors.

[0063] Fig. 13A shows the results of durable life test of the light emitting diodes of Example 1 and Comparative Example 1, showing the results at 25°C and Fig. 13B

shows the results of durable life test of the light emitting diodes of Example 1 and Comparative Example 1, showing the results at 60°C and 90%RH.

[0064] Fig. 14A shows the results of weatherability test of Example 9 and Comparative Example 2 showing the change of luminance retaining ratio with time and Fig. 14B shows the results of weatherability test of Example 9 and Comparative Example 2 showing the color tone before and after the test.

[0065] Fig. 15A shows the results of reliability test of Example 9 and Comparative Example 2 showing the relationship between the luminance retaining ratio and time, and Fig. 15B is a graph showing the relationship between color tone and time.

[0066] Fig. 16 is a chromaticity diagram showing the range of color tone which can be obtained with a light emitting diode which combines the fluorescent materials shown in Table 1 and blue LED having peak wavelength at 465 nm.

[0067] Fig. 17 is a chromaticity diagram showing the change in color tone when the concentration of fluorescent material is changed in the light emitting diode which combines the fluorescent materials shown in Table 1 and blue LED having peak wavelength at 465 nm.

[0068] Fig. 18A shows the emission spectrum of the phosphor $(Y_{0.6}Gd_{0.4})_3Al_5O_{12}:Ce$ of Example 18A.

[0069] Fig. 18B shows the emission spectrum of the light emitting component of Example 18B having the emission peak wavelength of 460nm.

[0070] Fig. 18C shows the emission spectrum of the light emitting diode of Example 2.

[0071] Fig. 19A shows the emission spectrum of the phosphor $(Y_{0.2}Gd_{0.8})_3Al_5O_{12}:Ce$ of Example 5.

[0072] Fig. 19B shows the emission spectrum of the light emitting component of Example 5 having the emission peak wavelength of 450nm.

[0073] Fig. 19C shows the emission spectrum of the light emitting diode of Example 5.

[0074] Fig. 20A shows the emission spectrum of the phosphor $Y_3Al_5O_{12}:Ce$ of Example 6.

[0075] Fig. 20B shows the emission spectrum of the light emitting component of Example 6 having the emission peak wavelength of 450nm.

[0076] Fig. 20C shows the emission spectrum of the light emitting diode of Example 6.

[0077] Fig. 21A shows the emission spectrum of the phosphor $Y_3(Al_{0.5}Ga_{0.5})_5O_{12}:Ce$ of the seventh embodiment of the present invention

[0078] Fig. 21B shows the emission spectrum of the light emitting component of Example 7 having the emission peak wavelength of 450nm.

[0079] Fig. 21C shows the emission spectrum of the light emitting diode of Example 7.

[0080] Fig. 22A shows the emission spectrum of the phosphor $(Y_{0.8}Gd_{0.2})_3Al_5O_{12}:Ce$ of Example 11.

[0081] Fig. 22B shows the emission spectrum of the phosphor $(Y_{0.4}Gd_{0.6})_3Al_5O_{12}:Ce$ of Example 11.

[0082] Fig. 22C shows the emission spectrum of the light emitting component of Example 11 having the emission peak wavelength of 470nm.

[0083] Fig. 23 shows the emission spectrum of the light emitting diode of Example 11.

DETAILED DESCRIPTION OF THE PREFERRED EMBODIMENTS

[0084] Now referring to the attached drawings, preferred embodiments of the present invention will be described below.

[0085] A light emitting diode 100 of Fig. 1 is a lead type light emitting diode having a mount lead 105 and an inner lead 106, wherein a light emitting component 102 is installed on a cup 105a of the mount lead 105, and the cup 105a is filled with a coating resin 101 which contains a specified phosphor to cover the light emitting component 102 and is molded in resin. An n electrode and a p electrode of the light emitting component 102 are connected to the mount lead 105 and the inner lead 106, respectively, by means of wires 103.

[0086] In the light emitting diode constituted as described above, part of light emitted by the light emitting component (LED chip) 102 (hereinafter referred to as LED light) excites the phosphor contained in the coating resin 101 to generate fluorescent light having a wavelength different from that of LED light, so that the fluorescent light emitted by the phosphor and LED light which is output without contributing to the excitation of the phosphor are mixed and output. As a result, the light emitting diode 100 also outputs light having a wavelength different from that of LED light emitted by the light emitting component 102.

[0087] Fig. 2 shows a chip type light emitting diode, wherein light emitting diode (LED chip) 202 is installed in a recess of a casing 204 which is filled with a coating material which contains a specified phosphor to form a coating 201. The light emitting component 202 is fixed by using an epoxy resin or the like which contains Ag, for example, and an n electrode and a p electrode of the light emitting component 202 are connected to metal terminals 205 installed on the casing 204 by means of conductive wires 203. In the chip type light emitting diode constituted as described above, similarly to the lead type light emitting diode of Fig. 1, fluorescent light emitted by the phosphor and LED light which is transmitted without being absorbed by the phosphor are mixed and output, so that the light emitting diode 200 also outputs light having a wavelength different from that of LED light emitted by the light emitting component 202.

[0088] The light emitting diode containing the phosphor as described above has the following features.

[0089] Light emitted by a light emitting component (LED) is usually emitted through an electrode which supplies electric power to the light emitting component. Emitted light is partly blocked by the electrode formed on the light emitting component resulting in a particular emission pattern, and is therefore not emitted uniformly in every direction. The light emitting diode which contains the fluorescent material, however, can emit light uniformly over a wide range without forming undesirable emission pattern because the light is emitted after being diffused by the fluorescent material.

[0090] Although light emitted by the light emitting component (LED) has a monochromatic peak, the peak is broad and has high color rendering property. This characteristic makes an indispensable advantage for an application which requires wavelengths of a relatively wide range. Light source for an optical image scanner, for example, is desirable to have a wider emission peak.

[0091] The light emitting diodes of the first and second embodiments to be described below have the configuration shown in Fig. 1 or Fig. 2 wherein a light emitting component which uses nitride compound semiconductor having relatively high energy in the visible region and a particular phosphor are combined, and have such favorable properties as capability to emit light of high luminance and less degradation of light emission efficiency and less color shift over an extended period of use.

[0092] In general, a fluorescent material which absorbs light of a short wavelength and emits light of a long wavelength has higher efficiency than a fluorescent material which absorbs light of a long wavelength and emits light of a short wavelength, and therefore it is preferable to use a nitride compound semiconductor light emitting component which is capable of emitting blue light of short wavelength. It needs not to say that the use of a light emitting component having high luminance is preferable.

[0093] A phosphor to be used in combination with the nitride compound semiconductor light emitting component must have the following requirements:

[0094] Excellent resistance against light to endure light of a high intensity for a long period of time, because the fluorescent material is installed in the vicinity of the light emitting components 102, 202 and is exposed to light of intensity as high as about 30 to 40 times that of sun light.

[0095] Capability to efficiently emit light in blue region for the excitation by means of the light emitting components 102, 202. When mixing of colors is used, should be capable of emitting blue light, not ultraviolet ray, with a high efficiency.

[0096] capability to emit light from green to red regions for the purpose of mixing with blue light to generate white light.

[0097] Good temperature characteristic suitable for location in the vicinity of the light emitting components 102, 202 and the resultant influence of temperature difference due to heat generated by the chip when lighting.

[0098] Capability to continuously change the color tone in terms of the proportion of composition or ratio of mixing a plurality of fluorescent materials.

[0099] Weatherability for the operating environment of the light emitting diode.

Embodiment 1

[0100] The light emitting diode of the first embodiment of the present invention employs a gallium nitride compound semiconductor element which has high-energy band gap in the light emitting layer and is capable of emitting blue light, and a garnet phosphor activated with cerium in combination. With this configuration, the light emitting diode of the first embodiment can emit white light by blending blue light emitted by the light emitting components 102, 202 and yellow light emitted by the phosphor excited by the blue light.

[0101] Because the garnet phosphor activated with cerium which is used in the light emitting diode of the first embodiment has light resistance and weatherability, it can emit light with extremely small degrees of color shift and decrease in the luminance of emitted light even when irradiated by very intense light emitted by the light emitting components 102, 202 located in the vicinity over a long period of time.

[0102] Components of the light emitting diode of the first embodiment will be described in detail below.

(Phosphor)

[0103] The phosphor used in the light emitting diode of the first embodiment is a phosphor which, when excited by visible light or ultraviolet ray emitted by the semiconductor light emitting layer, emits light of a wavelength different from that of the exciting light. The phosphor is specifically garnet fluorescent material activated with cerium which contains at least one element selected from Y, Lu, Sc, La, Gd and Sm and at least one element selected from Al, Ga and In. According to the present invention, the fluorescent material is preferably yttrium-aluminum-garnet fluorescent material (YAG phosphor) activated with cerium, or a fluorescent material represented by general formula $(\text{Re}_{1-r}\text{Sm}_r)_3(\text{Al}_{1-s}\text{Ga}_s)_5\text{O}_{12}:\text{Ce}$, where $0 \leq r < 1$ and $0 \leq s \leq 1$, and Re is at least one selected from Y and Gd. In case the LED light emitted by the light emitting component employing the gallium nitride compound semiconductor and the fluorescent light emitted by the phosphor having yellow body color are in the relation of complementary colors, white color can be output by blending the LED light and the fluorescent light.

[0104] In the first embodiment, because the phosphor is used by blending with a resin which makes the coating resin 101 and the coating material 201 (detailed later), color tone of the light emitting diode can be adjusted including white and incandescent lamp color by controlling the mixing proportion with the resin or the quantity used in

filling the cup 105 or the recess of the casing 204 in accordance to the wavelength of light emitted by the gallium nitride light emitting component.

[0105] Distribution of the phosphor concentration has influence also on the color blending and durability. That is, when the concentration of phosphor increases from the surface of the coating or molding where the phosphor is contained toward the light emitting component, it becomes less likely to be affected by extraneous moisture thereby making it easier to suppress the deterioration due to moisture. On the other hand, when the concentration of phosphor increases from the light emitting component toward the surface of the molding, it becomes more likely to be affected by extraneous moisture, but less likely to be affected by the heat and radiation from the light emitting component, thus making it possible to suppress the deterioration of the phosphor. Such distributions of the phosphor concentration can be achieved by selecting or controlling the material which contains the phosphor, forming temperature and viscosity, and the configuration and particle size distribution of the phosphor.

[0106] By using the phosphor of the first embodiment, light emitting diode having excellent emission characteristics can be made, because the fluorescent material has enough light resistance for high-efficient operation even when arranged adjacent to or in the vicinity of the light emitting components 102, 202 with radiation intensity

[0107] (Ee) within the range from 3 Wcm⁻² to 10 Wcm⁻².

[0108] The phosphor used in the first embodiment is, because of garnet structure, resistant to heat, light and moisture, and is therefore capable of absorbing excitation light having a peak at a wavelength near 450 nm as shown in Fig. 3A. It also emits light of broad spectrum having a peak near 580 nm tailing out to 700 nm as shown in Fig. 3B. Moreover, efficiency of excited light emission in a region of wavelengths 460 nm and higher can be increased by including Gd in the crystal of the phosphor of the first embodiment. When the Gd content is increased, emission peak wavelength is shifted toward longer wavelength and the entire emission spectrum is shifted toward longer

wavelengths. This means that, when emission of more reddish light is required, it can be achieved by increasing the degree of substitution with Gd. When the Gd content is increased, luminance of light emitted by photoluminescence under blue light tends to decrease.

[0109] Especially when part of Al is substituted with Ga among the composition of YAG fluorescent material having garnet structure, wavelength of emitted light shifts toward shorter wavelength and, when part of Y is substituted with Gd, wavelength of emitted light shifts toward longer wavelength.

[0110] Table 1 shows the composition and light emitting characteristics of YAG fluorescent material represented by general formula $(Y_{1-a}Gd_a)_3(Al_{1-b}Ga_b)5O_{12}:Ce$.

Table 1

	Gd content a (molar ratio)	Ga content b (molar ratio)	CIE chromaticity coordinates		Luminance Y	Efficiency
			X	y		
	0.0	0.0	0.41	0.56	100	100
	0.0	0.4	0.32	0.56	61	63
	0.0	0.5	0.29	0.54	55	67
	0.2	0.0	0.45	0.53	102	108
	0.4	0.0	0.47	0.52	102	113
	0.6	0.0	0.49	0.51	97	113
	0.8	0.0	0.50	0.50	72	86

[0111] Values shown in Table 1 were measured by exciting the fluorescent material with blue light of 460nm. Luminance and efficiency in Table 1 are given in values relative to those of material No. 1 which are set to 100.

[0112] When substituting Al with Ga, the proportion is preferably within the range from Ga: Al=1:1 to 4:6 in consideration of the emission efficiency and emission wavelength. Similarly, when substituting Y with Gd, the proportion is preferably within the range from Y: Gd=9:1 to 1:9, and more preferably from 4:1 to 2:3. It is because a degree of substitution with Gd below 20% results in a color of greater green component and less red component, and a degree of substitution with Gd above 60% results in increased red component but rapid decrease in luminance. When the ratio Y:Gd of Y and Gd in the YAG fluorescent material is set within the range from 4:1 to 2:3, in particular, a light emitting diode capable of emitting white light substantially along the black body radiation locus can be made by using one kind of yttrium-aluminum-garnet fluorescent material, depending on the emission wavelength of the light emitting component. When the ratio Y:Gd of Y and Gd in the YAG fluorescent material is set within the range from 2:3 to 1:4, a light emitting diode capable of emitting light of incandescent lamp can be made though the luminance is low. When the content (degree of substitution) of Ce is set within the range from 0.003 to 0.2, the relative luminous intensity of light emitting diode of not less than 70% can be achieved. When the content is less than 0.003, luminous intensity decreases because the number of excited emission centers of photoluminescence due to Ce decreases and, when the content is greater than 0.2, density quenching occurs.

[0113] Thus the wavelength of the emitted light can be shifted to a shorter wavelength by substituting part of Al of the composition with Ga, and the wavelength of the emitted light can be shifted to a longer wavelength by substituting part of Y of the composition with Gd. In this way, the light color of emission can be changed continuously by changing the composition. Also the fluorescent material is hardly excited by Hg emission lines which have such wavelengths as 254 nm and 365 nm, but is

excited with higher efficiency by LED light emitted by a blue light emitting component having a wavelength around 450 nm. Thus the fluorescent material has ideal characteristics for converting blue light of nitride semiconductor light emitting component into white light, such as the capability of continuously changing the peak wavelength by changing the proportion of Gd.

[0114] According to the first embodiment, the efficiency of light emission of the light emitting diode can be further improved by combining the light emitting component employing gallium nitride semiconductor and the phosphor made by adding rare earth element samarium (Sm) to yttrium-aluminum-garnet fluorescent materials (YAG) activated with cerium.

[0115] Material for making such a phosphor is made by using oxides of Y, Gd, Ce, Sm, Al and Ga or compounds which can be easily converted into these oxides at high temperature, and sufficiently mixing these materials in stoichiometrical proportions. This mixture is mixed with an appropriate quantity of a fluoride such as ammonium fluoride used as a flux, and fired in a crucible at a temperature from 1350 to 1450°C in air for 2 to 5 hours. Then the fired material is ground by a ball mill in water, washed, separated, dried and sieved thereby to obtain the desired material.

[0116] In the producing process described above, the mixture material may also be made by dissolving rare earth elements Y, Gd, Ce and Sm in stoichiometrical proportions in an acid, coprecipitating the solution with oxalic acid and firing the coprecipitate to obtain an oxide of the coprecipitate, and then mixing it with aluminum oxide and gallium oxide.

[0117] The phosphor represented by the general formula $(Y_{1-p-q-r}Gd_pCe_qSm_r)_{3Al_5O_{12}}$ can emit light of wavelengths 460nm and longer with higher efficiency upon excitation, because Gd is contained in the crystal. When the content of gadolinium is increased, peak wavelength of emission shifts from 530nm to a longer wavelength up to 570nm, while the entire emission spectrum also shifts to longer

wavelengths. When light of stronger red shade is needed, it can be achieved by increasing the amount of Gd added for substitution. When the content of Gd is increased, luminance of photoluminescence with blue light gradually decreases. Therefore, value of p is preferably 0.8 or lower, or more preferably 0.7 or lower. Further more preferably it is 0.6 or lower.

[0118] The phosphor represented by the general formula $(Y_{1-p-q-r}Gd_pCe_qSm_r)_{3Al_5O_{12}}$ including Sm can be made subject to less dependence on temperature regardless of the increased content of Gd. That is, the phosphor, when Sm is contained, has greatly improved emission luminance at higher temperatures. Extent of the improvement increases as the Gd content is increased. Temperature characteristic can be greatly improved particularly by the addition of Sm in the case of fluorescent material of such a composition as red shade is strengthened by increasing the content of Gd, because it has poor temperature characteristics. The temperature characteristic mentioned here is measured in terms of the ratio (%) of emission luminance of the fluorescent material at a high temperature (200°C) relative to the emission luminance of exciting blue light having a wavelength of 450nm at the normal temperature (25°C).

[0119] The proportion of Sm is preferably within the range of $0.0003 \leq r \leq 0.08$ to give temperature characteristic of 60% or higher. The value of r below this range leads to less effect of improving the temperature characteristic. When the value of r is above this range, on the contrary, the temperature characteristic deteriorates. The range of $0.0007 \leq r \leq 0.02$ for the proportion of Sm where temperature characteristic becomes 80% or higher is more desirable.

[0120] The proportion q of Ce is preferably in a range of $0.003 \leq q \leq 0.2$, which makes relative emission luminance of 70% or higher possible. The relative emission luminance refers to the emission luminance in terms of percentage to the emission luminance of a fluorescent material where $q=0.03$.

[0121] When the proportion q of Ce is 0.003 or lower, luminance decreases because the number of excited emission centers of photoluminescence due to Ce decreases and, when the q is greater than 0.2, density quenching occurs. Density quenching refers to the decrease in emission intensity which occurs when the concentration of an activation agent added to increase the luminance of the fluorescent material is increased beyond an optimum level.

[0122] For the light emitting diode of the present invention, a mixture of two or more kinds of phosphors having compositions of $(Y_{1-p-q-r}Gd_pCe_qSm_r)_3Al_5O_{12}$ having different contents of Al, Ga, Y and Gs or Sm may also be used. This increases the RGB components and enables the application, for example, for a full-color liquid crystal display device by using a color filter.

(Light emitting components 102, 202)

[0123] The light emitting component is preferably embedded in a molding material as shown in Fig. 1 and Fig. 2. The light emitting component used in the light emitting diode of the present invention is a gallium nitride compound semiconductor capable of efficiently exciting the garnet fluorescent materials activated with cerium. The light emitting components 102, 202 employing gallium nitride compound semiconductor are made by forming a light emitting layer of gallium nitride semiconductor such as InGaN on a substrate in the MOCVD process. The structure of the light emitting component may be homostructure, heterostructure or double-heterostructure which have MIS junction, PIN junction or PN junction. Various wavelengths of emission can be selected depending on the material of the semiconductor layer and the crystallinity thereof. It may also be made in a single quantum well structure or multiple quantum well structure where a semiconductor activation layer is formed as thin as quantum effect can occur. According to the present invention, a light emitting diode capable of emitting with higher luminance without deterioration of the phosphor

can be made by making the activation layer of the light emitting component in single quantum well structure of InGaN.

[0124] When a gallium nitride compound semiconductor is used, while sapphire, spinel, SiC, Si, ZnO or the like may be used as the semiconductor substrate, use of sapphire substrate is preferable in order to form gallium nitride of good crystallinity. A gallium nitride semiconductor layer is formed on the sapphire substrate to form a PN junction via a buffer layer of GaN, AlN, etc. The gallium nitride semiconductor has N type conductivity under the condition of not doped with any impurity, although in order to form an N type gallium nitride semiconductor having desired properties (carrier concentration, etc.) such as improved light emission efficiency, it is preferably doped with N type dopant such as Si, Ge, Se, Te, and C. In order to form a P type gallium nitride semiconductor, on the other hand, it is preferably doped with P type dopant such as Zn, Mg, Be, Ca, Sr and Ba. Because it is difficult to turn a gallium nitride compound semiconductor to P type simply by doping a P type dopant, it is preferable to treat the gallium nitride compound semiconductor doped with P type dopant in such process as heating in a furnace, irradiation with low-speed electron beam and plasma irradiation, thereby to turn it to P type. After exposing the surfaces of P type and N type gallium nitride semiconductors by the etching or other process, electrodes of the desired shapes are formed on the semiconductor layers by sputtering or vapor deposition.

[0125] Then the semiconductor wafer which has been formed is cut into pieces by means of a dicing saw, or separated by an external force after cutting grooves (half-cut) which have width greater than the blade edge width. Or otherwise, the wafer is cut into chips by scribing grid pattern of extremely fine lines on the semiconductor wafer by means of a scriber having a diamond stylus which makes straight reciprocal movement. Thus the light emitting component of gallium nitride compound semiconductor can be made.

[0126] In order to emit white light with the light emitting diode of the first embodiment, wavelength of light emitted by the light emitting component is preferably from 400nm to 530nm inclusive in consideration of the complementary color relationship with the phosphor and deterioration of resin, and more preferably from 420nm to 490nm inclusive. It is further more preferable that the wavelength be from 450nm to 475nm, in order to improve the emission efficiency of the light emitting component and the phosphor. Emission spectrum of the white light emitting diode of the first embodiment is shown in Fig. 4. The light emitting component shown here is of lead type shown in Fig. 1, which employs the light emitting component and the phosphor of the first embodiment to be described later. In Fig. 4, emission having a peak around 450 nm is the light emitted by the light emitting component, and emission having a peak around 570 nm is the photoluminescent emission excited by the light emitting component.

[0127] Fig. 16 shows the colors which can be represented by the white light emitting diode made by combining the fluorescent material shown in Table 1 and blue LED (light emitting component) having peak wavelength 465nm. Color of light emitted by this white light emitting diode corresponds to a point on a straight line connecting a point of chromaticity generated by the blue LED and a point of chromaticity generated by the fluorescent material, and therefore the wide white color region (shaded portion in Fig. 16) in the central portion of the chromaticity diagram can be fully covered by using the fluorescent materials 1 to 7 in Table 1. Fig. 17 shows the change in emission color when the contents of fluorescent materials in the white light emitting diode is changed. Contents of fluorescent materials are given in weight percentage to the resin used in the coating material. As will be seen from Fig. 17, color of the light approaches that of the fluorescent materials when the content of fluorescent material is increased and approaches that of blue LED when the content of fluorescent material decreased.

[0128] According to the present invention, a light emitting component which does not excite the fluorescent material may be used together with the light emitting

component which emits light that excites the fluorescent material. Specifically, in addition to the fluorescent material which is a nitride compound semiconductor capable of exciting the fluorescent material, a light emitting component having a light emitting layer made of gallium phosphate, gallium aluminum arsenide, gallium arsenic phosphate or indium aluminum phosphate is arranged together. With this configuration, light emitted by the light emitting component which does not excite the fluorescent material is radiated to the outside without being absorbed by the fluorescent material, making a light emitting diode which can emit red/white light.

[0129] Other components of the light emitting diodes of Fig. 1 and Fig. 2 will be described below.

(Conductive wires 103, 203)

[0130] The conductive wires 103, 203 should have good electric conductivity, good thermal conductivity and good mechanical connection with the electrodes of the light emitting components 102, 202. Thermal conductivity is preferably $0.01 \text{ cal/(s)(cm}^2\text{)(}^\circ\text{C/cm)}$ or higher, and more preferably $0.5 \text{ cal/(s)(cm}^2\text{)(}^\circ\text{C/cm)}$ or higher. For workability, diameter of the conductive wire is preferably from $10\mu\text{m}$ to $45\mu\text{m}$ inclusive. Even when the same material is used for both the coating including the fluorescent material and the molding, because of the difference in thermal expansion coefficient due to the fluorescent material contained in either of the above two materials, the conductive wire is likely to break at the interface. For this reason, diameter of the conductive wire is preferably not less than $25\mu\text{m}$ and, for the reason of light emitting area and ease of handling, preferably within $35\mu\text{m}$. The conductive wire may be a metal such as gold, copper, platinum and aluminum or an alloy thereof. When a conductive wire of such material and configuration is used, it can be easily connected to the electrodes of the light emitting components, the inner lead and the mount lead by means of a wire bonding device.

(Mount lead 105)

[0131] The mount lead 105 comprises a cup 105a and a lead 105b, and it suffices to have a size enough for mounting the light emitting component 102 with the wire bonding device in the cup 105a. In case a plurality of light emitting components are installed in the cup and the mount lead is used as common electrode for the light emitting component, because different electrode materials may be used, sufficient electrical conductivity and good conductivity with the bonding wire and others are required. When the light emitting component is installed in the cup of the mount lead and the cup is filled with the fluorescent material, light emitted by the fluorescent material is, even if isotropic, reflected by the cup in a desired direction and therefore erroneous illumination due to light from other light emitting diode mounted nearby can be prevented. Erroneous illumination here refers to such a phenomenon as other light emitting diode mounted nearby appearing as though lighting despite not being supplied with power.

[0132] Bonding of the light emitting component 102 and the mount lead 105 with the cup 105a can be achieved by means of a thermoplastic resin such as epoxy resin, acrylic resin and imide resin. When a face-down light emitting component (such a type of light emitting component as emitted light is extracted from the substrate side and is configured for mounting the electrodes to oppose the cup 105a) is used, Ag paste, carbon paste, metallic bump or the like can be used for bonding and electrically connecting the light emitting component and the mount lead at the same time. Further, in order to improve the efficiency of light utilization of the light emitting diode, surface of the cup of the mount lead whereon the light emitting component is mounted may be mirror-polished to give reflecting function to the surface. In this case, the surface roughness is preferably from 0.1S to 0.8 S inclusive. Electric resistance of the mount lead is preferably within $300\mu\Omega\text{-cm}$ and more preferably within $3\mu\Omega\text{-cm}$. When mounting a plurality of light emitting components on the mount lead, the light emitting components generate significant amount of heat and therefore high thermal conductivity is required.

Specifically, the thermal conductivity is preferably $0.01 \text{ cal/(s)(cm}^2\text{)(}^\circ\text{C/cm)}$ or higher, and more preferably $0.5 \text{ cal/(s)(cm}^2\text{)(}^\circ\text{C/cm)}$ or higher. Materials which satisfy these requirements contain steel, copper, copper-clad steel, copper-clad tin and metallized ceramics.

(Inner lead 106)

[0133] The inner lead 106 is connected to one of electrodes of the light emitting component 102 mounted on the mount lead 105 by means of conductive wire or the like. In the case of a light emitting diode where a plurality of the light emitting components are installed on the mount lead, it is necessary to arrange a plurality of inner leads 106 in such a manner that the conductive wires do not touch each other. For example, contact of the conductive wires with each other can be prevented by increasing the area of the end face where the inner lead is wire-bonded as the distance from the mount lead increases so that the space between the conductive wires is secured. Surface roughness of the inner lead end face connecting with the conductive wire is preferably from 1.6 S to 10 S inclusive in consideration of close contact. In order to form the inner lead in a desired shape, it may be punched by means of a die. Further, it may be made by punching to form the inner lead then pressurizing it on the end face thereby to control the area and height of the end face.

[0134] The inner lead is required to have good connectivity with the bonding wires which are conductive wires and have good electrical conductivity. Specifically, the electric resistance is preferably within $300\mu\Omega\cdot\text{cm}$ and more preferably within $3\mu\Omega\cdot\text{cm}$. Materials which satisfy these requirements contain iron, copper, iron-containing copper, tin-containing copper, copper-, gold- or silver-plated aluminum, iron and copper.

(Coating material 101)

[0135] The coating material 101 is provided in the cup of the mount lead apart from the molding material 104 and, in the first embodiment, contains the phosphor which converts the light emitted by the light emitting component. The coating material may be a transparent material having good weatherability such as epoxy resin, urea resin and silicone or glass. A dispersant may be used together with the phosphor. As the dispersant, barium titanate, titanium oxide, aluminum oxide, silicon dioxide and the like are preferably used. When the fluorescent material is formed by sputtering, coating material may be omitted. In this case, a light emitting diode capable of bending colors can be made by controlling the film thickness or providing an aperture in the fluorescent material layer.

(Molding material 104)

[0136] The molding 104 has the function to protect the light emitting component 102, the conductive wire 103 and the coating material 101 which contains phosphor from external disturbance. According to the first embodiment, it is preferable that the molding material 104 further contain a dispersant, which can unsharpen the directivity of light from the light emitting component 102, resulting in increased angle of view. The molding material 104 has the function of lens to focus or diffuse the light emitted by the light emitting component. Therefore, the molding material 104 may be made in a configuration of convex lens or concave lens, and may have an elliptic shape when viewed in the direction of optical axis, or a combination of these. Also the molding material 104 may be made in a structure of multiple layers of different materials being laminated. As the molding material 104, transparent materials having high weatherability such as epoxy resin, urea resin, silicon resin or glass is preferably employed. As the dispersant, barium titanate, titanium oxide, aluminum oxide, silicon dioxide and the like can be used. In addition to the dispersant, phosphor may also be contained in the

molding material. Namely, according to the present invention, the phosphor may be contained either in the molding material or in the coating material. When the phosphor is contained in the molding material, angle of view can be further increased. The phosphor may also be contained in both the coating material and the molding material. Further, a resin including the phosphor may be used as the coating material while using glass, different from the coating material, as the molding material. This makes it possible to manufacture a light emitting diode which is less subject to the influence of moisture with good productivity. The molding and the coating may also be made of the same material in order to match the refractive index, depending on the application. According to the present invention, adding the dispersant and/or a coloration agent in the molding material has the effects of masking the color of the fluorescent material obscured and improving the color mixing performance. That is, the fluorescent material absorbs blue component of extraneous light and emits light thereby to give such an appearance as though colored in yellow. However, the dispersant contained in the molding material gives milky white color to the molding material and the coloration agent renders a desired color. Thus the color of the fluorescent material will not be recognized by the observer. In case the light emitting component emits light having main wavelength of 430nm or over, it is more preferable that ultraviolet absorber which serves as light stabilizer be contained.

Embodiment 2

[0137] The light emitting diode of the second embodiment of the present invention is made by using an element provided with gallium nitride compound semiconductor which has high-energy band gap in the light emitting layer as the light emitting component and a fluorescent material including two or more kinds of phosphors of different compositions, or preferably yttrium-aluminum-garnet fluorescent materials activated with cerium as the phosphor. With this configuration, a light emitting diode which allows to give a desired color tone by controlling the contents of the two or more

fluorescent materials can be made even when the wavelength of the LED light emitted by the light emitting component deviates from the desired value due to variations in the production process. In this case, emission color of the light emitting diode can be made constantly using a fluorescent material having a relatively short emission wavelength for a light emitting component of a relatively short emission wavelength and using a fluorescent material having a relatively long emission wavelength for a light emitting component of a relatively long emission wavelength.

[0138] As for the fluorescent material, a fluorescent material represented by general formula $(Re_{1-r}Sm_r)_3(Al_{1-s}Ga_s)_5O_{12}:Ce$ may also be used as the phosphor. Here $0 \leq r < 1$ and $0 \leq s \leq 1$, and Re is at least one selected from Y, Gd and La. This configuration makes it possible to minimize the denaturing of the fluorescent material even when the fluorescent material is exposed to high-intensity high-energy visible light emitted by the light emitting component for a long period of time or when used under various environmental conditions, and therefore a light emitting diode which is subject to extremely insignificant color shift and emission luminance decrease and has the desired emission component of high luminance can be made.

(Phosphor of the second embodiment)

[0139] Now the phosphor used in the light emitting component of the second embodiment will be described in detail below. The second embodiment is similar to the first embodiment, except that two or more kinds of phosphors of different compositions activated with cerium are used as the phosphor, as described above, and the method of using the fluorescent material is basically the same.

[0140] Similarly to the case of the first embodiment, the light emitting diode can be given high weatherability by controlling the distribution of the phosphor (such as tapering the concentration with the distance from the light emitting component). Such a distribution of the phosphor concentration can be achieved by selecting or controlling the

material which contains the phosphor, forming temperature and viscosity, and the configuration and particle size distribution of the phosphor. Thus, according to the second embodiment, distribution of the fluorescent material concentration is determined according to the operating conditions. Also, according to the second embodiment, efficiency of light emission can be increased by designing the arrangement of the two or more kinds of fluorescent materials (for example, arranging in the order of nearness to the light emitting component) according to the light generated by the light emitting component.

[0141] With the configuration of the second embodiment, similarly to the first embodiment, light emitting diode has high efficiency and enough light resistance even when arranged adjacent to or in the vicinity of relatively high-output light emitting component with radiation intensity (E_e) within the range from 3 Wcm^{-2} to 10 Wcm^{-2} can be made.

[0142] The yttrium-aluminum-garnet fluorescent material activated with cerium (YAG fluorescent material) used in the second embodiment has garnet structure similarly to the case of the first embodiment, and is therefore resistant to heat, light and moisture. The peak wavelength of excitation of the yttrium-aluminum-garnet fluorescent material of the second embodiment can be set near 450nm as indicated by the solid line in Fig. 5A, and the peak wavelength of emission can be set near 510nm as indicated by the solid line in Fig. 5B, while making the emission spectrum so broad as to tail out to 700nm. This makes it possible to emit green light. The peak wavelength of excitation of another yttrium-aluminum-garnet fluorescent material activated with cerium of the second embodiment can be set near 450nm as indicated by the dashed line in Fig. 5A, and the peak wavelength of emission can be set near 600nm as indicated by the dashed line in Fig. 5B, while making the emission spectrum so broad as to tail out to 750nm. This makes it possible to emit red light.

[0143] Wavelength of the emitted light is shifted to a shorter wavelength by substituting part of Al, among the constituents of the YAG fluorescent material having garnet structure, with Ga, and the wavelength of the emitted light is shifted to a longer wavelength by substituting part of Y with Gd and/or La. Proportion of substituting Al with Ga is preferably from Ga:Al=1:1 to 4:6 in consideration of the light emitting efficiency and the wavelength of emission. Similarly, proportion of substituting Y with Gd and/or La is preferably from Y:Gd and/or La=9:1 to 1:9, or more preferably from Y:Gd and/or La=4:1 to 2:3. Substitution of less than 20% results in an increase of green component and a decrease of red component. Substitution of 80% or greater part, on the other hand, increases red component but decreases the luminance steeply.

[0144] Material for making such a phosphor is made by using oxides of Y, Gd, Ce, La, Al, Sm and Ga or compounds which can be easily converted into these oxides at high temperature, and sufficiently mixing these materials in stoichiometrical proportions. Or either, mixture material is obtained by dissolving rare earth elements Y, Gd, Ce, La and Sm in stoichiometrical proportions in acid, coprecipitating the solution oxalic acid and firing the coprecipitate to obtain an oxide of the coprecipitate, which is then mixed with aluminum oxide and gallium oxide. This mixture is mixed with an appropriate quantity of a fluoride such as ammonium fluoride used as a flux, and fired in a crucible at a temperature from 1350 to 1450 °C in air for 2 to 5 hours. Then the fired material is ground by a ball mill in water, washed, separated, dried and sieved thereby to obtain the desired material.

[0145] In the second embodiment, the two or more kinds of yttrium-aluminum-garnet fluorescent materials activated with cerium of different compositions may be either used by mixing or arranged independently (laminated, for example). When the two or more kinds of fluorescent materials are mixed, color converting portion can be formed relatively easily and in a manner suitable for mass production. When the two or more kinds of fluorescent materials are arranged independently, color can be adjusted after

forming it by laminating the layers until a desired color can be obtained. Also when arranging the two or more kinds of fluorescent materials independently, it is preferable to arrange a fluorescent material that absorbs light from the light emitting component of a shorter wavelength near to the LED element, and a fluorescent material that absorbs light of a longer wavelength away from the LED element. This arrangement enables efficient absorption and emission of light.

[0146] The light emitting diode of the second embodiment is made by using two or more kinds of yttrium-aluminum-garnet fluorescent materials of different compositions as the fluorescent materials, as described above. This makes it possible to make a light emitting diode capable of emitting light of desired color efficiently. That is, when wavelength of light emitted by the semiconductor light emitting component corresponds to a point on the straight line connecting point A and point B in the chromaticity diagram of Fig. 6, light of any color in the shaded region enclosed by points A, B, C and D in Fig. 6 which is the chromaticity points (points C and D) of the two or more kinds of yttrium-aluminum-garnet fluorescent materials of different compositions can be emitted. According to the second embodiment, color can be controlled by changing the compositions or quantities of the LED elements and fluorescent materials. In particular, a light emitting diode of less variation in the emission wavelength can be made by selecting the fluorescent materials according to the emission wavelength of the LED element, thereby compensating for the variation of the emission wavelength of the LED element. Also a light emitting diode including RGB components with high luminance can be made by selecting the emission wavelength of the fluorescent materials.

[0147] Moreover, because the yttrium-aluminum-garnet (YAG) fluorescent material used in the second embodiment has garnet structure, the light emitting diode of the second embodiment can emit light of high luminance for a long period of time. Also the light emitting diodes of the first embodiment and the second embodiment are provided with light emitting component installed via fluorescent material. Also because

the converted light has longer wavelength than that of the light emitted by the light emitting component, energy of the converted light is less than the band gap of the nitride semiconductor, and is less likely to be absorbed by the nitride semiconductor layer. Thus, although the light emitted by the fluorescent material is directed also to the LED element because of the isotropy of emission, the light emitted by the fluorescent material is never absorbed by the LED element, and therefore the emission efficiency of the light emitting diode will not be decreased.

(Planar light source)

[0148] A planar light source which is another embodiment of the present invention is shown in Fig. 7.

[0149] In the planar light source shown in the Fig. 7, the phosphor used in the first embodiment or the second embodiment is contained in a coating material 701. With this configuration, blue light emitted by the gallium nitride semiconductor is color-converted and is output in planar state via an optical guide plate 704 and a dispersive sheet 706.

[0150] Specifically, a light emitting component 702 of the planar light source of Fig. 7 is secured in a metal substrate 703 of inverted C shape whereon an insulation layer and a conductive pattern (not shown) are formed. After electrically connecting the electrode of the light emitting component and the conductive pattern, phosphor is mixed with epoxy resin and applied into the inverse C-shaped metal substrate 703 whereon the light emitting component 702 is mounted. The light emitting component thus secured is fixed onto an end face of an acrylic optical guide plate 704 by means of an epoxy resin. A reflector film 707 containing a white diffusion agent is arranged on one of principal planes of the optical guide plate 704 where the dispersive sheet 706 is not formed, for the purpose of preventing fluorescence.

[0151] Similarly, a reflector 705 is provided on the entire surface on the back of the optical guide plate 704 and on one end face where the light emitting component is not provided, in order to improve the light emission efficiency. With this configuration, light emitting diodes for planar light emission which generates enough luminance for the back light of LCD can be made.

[0152] Application of the light emitting diode for planar light emission to a liquid crystal display can be achieved by arranging a polarizer plate on one principal plane of the optical guide plate 704 via liquid crystal injected between glass substrates (not shown) whereon a translucent conductive pattern is formed.

[0153] Now referring to Fig. 8 and Fig. 9, a planar light source according to another embodiment of the present invention will be described below. The light emitting device shown in Fig. 8 is made in such a configuration that blue light emitted by the light emitting diode 702 is converted to white light by a color converter 701 which contains phosphor and is output in planar state via an optical guide plate 704.

[0154] The light emitting device shown in Fig. 9 is made in such a configuration that blue light emitted by the light emitting component 702 is turned to planar state by the optical guide plate 704, then converted to white light by a dispersive sheet 706 which contains phosphor formed on one of the principal plane of the optical guide plate 704, thereby to output white light in planar state. The phosphor may be either contained in the dispersive sheet 706 or formed in a sheet by spreading it together with a binder resin over the dispersive sheet 706. Further, the binder including the phosphor may be formed in dots, not sheet, directly on the optical guide plate 704.

<Application>

(Display device)

[0155] Now a display device according to the present invention will be described below. Fig. 10 is a block diagram showing the configuration of the display device

according to the present invention. As shown in Fig. 10, the display device comprises an LED display device 601 and a drive circuit 610 having a driver 602, video data storage means 603 and tone control means 604. The LED display device 601, having white light emitting diodes 501 shown in Fig. 1 or Fig. 2 arranged in matrix configuration in a casing 504 as shown in Fig. 11, is used as monochromatic LED display device. The casing 504 is provided with a light blocking material 505 being formed integrally therewith.

[0156] The drive circuit 610 has the video data storage means (RAM) 603 for temporarily storing display data which is input, the tone control means 604 which computes and outputs tone signals for controlling the individual light emitting diodes of the LED display device 601 to light with the specified brightness according to the data read from RAM 603, and the driver 602 which is switched by signals supplied from the tone control means 604 to drive the light emitting diode to light. The tone control circuit 604 retrieves data from the RAM 603 and computes the duration of lighting the light emitting diodes of the LED display device 601, then outputs pulse signals for turning on and off the light emitting diodes to the LED display device 601. In the display device constituted as described above, the LED display device 601 is capable of displaying images according to the pulse signals which are input from the drive circuit, and has the following advantages.

[0157] The LED display device which displays with white light by using light emitting diodes of three colors, RGB, is required to display while controlling the light emission output of the R, G and B light emitting diodes and accordingly must control the light emitting diodes by taking the emission intensity, temperature characteristics and other factors of the light emitting diodes into account, resulting in complicate configuration of the drive circuit which drives the LED display device. In the display device of the present invention, however, because the LED display device 601 is constituted by using light emitting diodes 501 of the present invention which can emit white light without using light emitting diodes of three kinds, RGB, it is not necessary for

the drive circuit to individually control the R, G and B light emitting diodes, making it possible to simplify the configuration of the drive circuit and make the display device at a low cost.

[0158] With an LED display device which displays in white light by using light emitting diodes of three kinds, RGB, the three light emitting diodes must be illuminated at the same time and the light from the light emitting diodes must be mixed in order to display white light by combining the three RGB light emitting diodes for each pixel, resulting in a large display area for each pixel and making it impossible to display with high definition. The LED display device of the display device according to the present invention, in contrast, can display with white light can be done with a single light emitting diode, and is therefore capable of display with white light of higher definition. Further, with the LED display device which displays by mixing the colors of three light emitting diodes, there is such a case as the display color changes due to blocking of some of the RGB light emitting diodes depending on the viewing angle, the LED display device of the present invention has no such problem.

[0159] As described above, the display device provided with the LED display device employing the light emitting diode of the present invention which is capable of emitting white light is capable of displaying stable white light with higher definition and has an advantage of less color unevenness. The LED display device of the present invention which is capable of displaying with white light also imposes less stimulation to the eye compared to the conventional LED display device which employs only red and green colors, and is therefore suited for use over a long period of time.

(Embodiment of another display device employing the light emitting diode of the present invention)

[0160] The light emitting diode of the present invention can be used to constitute an LED display device wherein one pixel is constituted of three RGB light emitting

diodes and one light emitting diode of the present invention, as shown in Fig. 12. By connecting the LED display device and a specified drive circuit, a display device capable of displaying various images can be constituted. The drive circuit of this display device has, similarly to a case of monochrome display device, video data storage means (RAM) for temporarily storing the input display data, a tone control circuit which processes the data stored in the RAM to compute tone signals for lighting the light emitting diodes with specified brightness and a driver which is switched by the output signal of the tone control circuit to cause the light emitting diodes to illuminate. The drive circuit is required exclusively for each of the RGB light emitting diodes and the white light emitting diode. The tone control circuit computes the duration of lighting the light emitting diodes from the data stored in the RAM, and outputs pulse signals for turning on and off the light emitting diodes. When displaying with white light, width of the pulse signals for lighting the RGB light emitting diodes is made shorter, or peak value of the pulse signal is made lower or no pulse signal is output at all. On the other hand, a pulse signal is given to the white light emitting diode in compensation thereof. This causes the LED display device to display with white light.

[0161] As described above, brightness of display can be improved by adding the white light emitting diode to the RGB light emitting diodes. When RGB light emitting diodes are combined to display white light, one or two of the RGB colors may be enhanced resulting in a failure to display pure white depending on the viewing angle, such a problem is solved by adding the white light emitting diode as in this display device.

[0162] For the drive circuit of such a display device as described above, it is preferable that a CPU be provided separately as a tone control circuit which computes the pulse signal for lighting the white light emitting diode with specified brightness. The pulse signal which is output from the tone control circuit is given to the white light emitting diode driver thereby to switch the driver. The white light emitting diode illuminates when the driver is turned on, and goes out when the driver is turned off.

(Traffic signal)

[0163] When the light emitting diode of the present invention is used as a traffic signal which is a kind of display device, such advantages can be obtained as stable illumination over a long period of time and no color unevenness even when part of the light emitting diodes go out. The traffic signal employing the light emitting diode of the present invention has such a configuration as white light emitting diodes are arranged on a substrate whereon a conductive pattern is formed. A circuit of light emitting diodes wherein such light emitting diodes are connected in series or parallel is handled as a set of light emitting diodes. Two or more sets of the light emitting diodes are used, each having the light emitting diodes arranged in spiral configuration. When all light emitting diodes are arranged, they are arranged over the entire area in circular configuration. After connecting power lines by soldering for the connection of the light emitting diodes and the substrate with external power supply, it is secured in a chassis of railway signal. The LED display device is placed in an aluminum diecast chassis equipped with a light blocking member and is sealed on the surface with silicon rubber filler. The chassis is provided with a white color lens on the display plane thereof. Electric wiring of the LED display device is passed through a rubber packing on the back of the chassis, for sealing off the inside of the chassis from the outside, with the inside of the chassis closed. Thus a signal of white light is made. A signal of higher reliability can be made by dividing the light emitting diodes of the present invention into a plurality of groups and arranging them in a spiral configuration swirling from a center toward outside, while connecting them in parallel. The configuration of swirling from the center toward outside may be either continuous or intermittent. Therefore, desired number of the light emitting diodes and desired number of the sets of light emitting diodes can be selected depending on the display area of the LED display device. This signal is, even when one of the sets of light emitting diodes or part of the light emitting diodes fail to illuminate due to some trouble, capable of illuminate evenly in a circular configuration without color shift by means of

the remaining set of light emitting diodes or remaining light emitting diodes. Because the light emitting diodes are arranged in a spiral configuration, they can be arranged more densely near the center, and driven without any different impression from signals employing incandescent lamps.

<Examples>

[0164] The following Examples further illustrate the present invention in detail but are not to be construed to limit the scope thereof.

(Example 1)

[0165] Example 1 provides a light emitting component having an emission peak at 450nm and a half width of 30nm employing a GaInN semiconductor. The light emitting component of the present invention is made by flowing TMG (trimethyl gallium) gas, TMI (trimethyl indium) gas, nitrogen gas and dopant gas together with a carrier gas on a cleaned sapphire substrate and forming a gallium nitride compound semiconductor layer in MOCVD process. A gallium nitride semiconductor having N type conductivity and a gallium nitride semiconductor having P type conductivity are formed by switching SiH₄ and Cp₂Mg as dopant gas. The LED element of Example 1 has a contact layer which is a gallium nitride semiconductor having N type conductivity, a clad layer which is a gallium nitride aluminum semiconductor having P type conductivity and a contact layer which is a gallium nitride semiconductor having P type conductivity, and formed between the contact layer having N type conductivity and the clad layer having P type conductivity is a non-doped InGaN activation layer of thickness about 3 nm for making a single quantum well structure. The sapphire substrate has a gallium nitride semiconductor layer formed thereon under a low temperature to make a buffer layer. The P type semiconductor is annealed at a temperature of 400°C or above after forming the film.

[0166] After exposing the surfaces of P type and N type semiconductor layers by etching, n and p electrodes are formed by sputtering. After scribing the semiconductor wafer which has been made as described above, light emitting components are made by dividing the wafer with external force.

[0167] The light emitting component made in the above process is mounted in a cup of a mount lead which is made of silver-plated steel by die bonding with epoxy resin. Then electrodes of the light emitting component, the mount lead and the inner lead are electrically connected by wire bonding with gold wires 30 μ m in diameter, to make a light emitting diode of lead type.

[0168] A phosphor is made by dissolving rare earth elements of Y, Gd and Ce in an acid in stoichiometrical proportions, and coprecipitating the solution with oxalic acid. Oxide of the coprecipitate obtained by firing this material is mixed with aluminum oxide, thereby to obtain the mixture material. The mixture was then mixed with ammonium fluoride used as a flux, and fired in a crucible at a temperature of 1400°C in air for 3 hours. Then the fired material is ground by a ball mill in water, washed, separated, dried and sieved thereby to obtain the desired material. Phosphor made as describe above is yttrium-aluminum-garnet fluorescent material represented by general formula $(Y_{0.8}Gd_{0.2})_3Al_5O_{12}:Ce$ where about 20% of Y is substituted with Gd and substitution ratio of Ce is 0.03.

[0169] 80 Parts by weight of the fluorescent material having a composition of $(Y_{0.8}Gd_{0.2})_3Al_5O_{12}:Ce$ which has been made in the above process and 100 parts by weight of epoxy resin are sufficiently mixed to turn into slurry. The slurry is poured into the cup provided on the mount lead whereon the light emitting component is mounted. After pouring, the slurry is cured at 130°C for one hour. Thus a coating having a thickness of 120 μ m, which contains the phosphor, is formed on the light emitting component. In Example 1, the coating is formed to contain the phosphor in gradually increasing concentration toward the light emitting component. Irradiation intensity is

about 3.5W/cm². The light emitting component and the phosphor are molded with translucent epoxy resin for the purpose of protection against extraneous stress, moisture and dust. A lead frame with the coating layer of phosphor formed thereon is placed in a bullet-shaped die and mixed with translucent epoxy resin and then cured at 150 °C for 5 hours.

[0170] Under visual observation of the light emitting diode formed as described above in the direction normal to the light emitting plane, it was found that the central portion was rendered yellowish color due to the body color of the phosphor.

[0171] Measurements of chromaticity point, color temperature and color rendering index of the light emitting diode made as described above and capable of emitting white light gave values of (0.302, 0.280) for chromaticity point (x, y), color temperature of 8080 K and 87.5 for color rendering index (Ra) which are approximate to the characteristics of a 3-waveform fluorescent lamp. Light emitting efficiency was 9.5 lm/W, comparable to that of an incandescent lamp. Further in life tests under conditions of energization with a current of 60mA at 25°C, 20mA at 25°C and 20mA at 60°C with 90% RH, no change due to the fluorescent material was observed, proving that the light emitting diode had no difference in service life from the conventional blue light emitting diode.

(Comparative Example 1)

[0172] Formation of a light emitting diode and life tests thereof were conducted in the same manner as in Example 1 except for changing the phosphor from (Y_{0.8}Gd_{0.2})₃Al₅O₁₂:Ce to (ZnCd)S:Cu, Al. The light emitting diode which had been formed showed, immediately after energization, emission of white light but with low luminance. In a life test, the output diminished to zero in about 100 hours. Analysis of the cause of deterioration showed that the fluorescent material was blackened.

[0173] This trouble is supposed to have been caused as the light emitted by the light emitting component and moisture which had caught on the fluorescent material or entered from the outside brought about photolysis to make colloidal zinc to precipitate on the surface of the fluorescent material, resulting in blackened surface. Results of life tests under conditions of energization with a current of 20mA at 25 °C and 20mA at 60 °C with 90% RH are shown in Fig. 13 together with the results of Example 1. Luminance is given in terms of relative value with respect to the initial value as the reference. A solid line indicates Example 1 and a wavy line indicates Comparative Example 1 in Fig. 13.

(Example 2)

[0174] In Example 2, a light emitting component was made in the same manner as in Example 1 except for increasing the content of In in the nitride compound semiconductor of the light emitting component to have the emission peak at 460 nm and increasing the content of Gd in phosphor than that of Example 1 to have a composition of $(Y_{0.6}Gd_{0.4})_3Al_5O_{12}:Ce$.

[0175] Measurements of chromaticity point, color temperature and color rendering index of the light emitting diode, which were made as described above and capable of emitting white light, gave values of (0.375, 0.370) for chromaticity point (x, y), color temperature of 4400 K and 86.0 for color rendering index (Ra). Fig. 18A, Fig. 18B and Fig. 18C show the emission spectra of the phosphor, the light emitting component and the light emitting diode of Example 2, respectively.

[0176] 100 pieces of the light emitting diodes of Example 2 were made and average luminous intensities thereof were taken after lighting for 1000 hours. In terms of percentage of the luminous intensity value before the life test, the average luminous intensity after the life test was 98.8%, proving no difference in the characteristic.

(Example 3)

[0177] 100 light emitting diodes were made in the same manner as in Example 1 except for adding Sm in addition to rare earth elements Y, Gd and Ce in the phosphor to make a fluorescent material with composition of $(Y_{0.39}Gd_{0.57}Ce_{0.03}Sm_{0.01})_3Al_5O_{12}$. When the light emitting diodes were made illuminate at a high temperature of 130 °C, average temperature characteristic about 8% better than that of Example 1 was obtained.

(Example 4)

[0178] LED display device of Example 4 is made of the light emitting diodes of Example 1 being arranged in a 16 x 16 matrix on a ceramics substrate whereon a copper pattern is formed as shown in Fig. 11. In the LED display device of Example 4, the substrate whereon the light emitting diodes are arranged is placed in a chassis 504 which is made of phenol resin and is provided with a light blocking member 505 being formed integrally therewith. The chassis, the light emitting diodes, the substrate and part of the light blocking member, except for the tips of the light emitting diodes, are covered with silicon rubber 506 colored in black with a pigment. The substrate and the light emitting diodes are soldered by means of an automatic soldering machine.

[0179] The LED display device made in the configuration described above, a RAM which temporarily stores the input display data, a tone control circuit which processes the data stored in the RAM to compute tone signals for lighting the light emitting diodes with specified brightness and drive means which is switched by the output signal of the tone control circuit to cause the light emitting diodes to illuminate are electrically connected to make an LED display device. By driving the LED display devices, it was verified that the apparatus can be used as black and white LED display device.

(Example 5)

[0180] The light emitting diode of Example 5 was made in the same manner as in Example 1 except for using phosphor represented by general formula $(Y_{0.2}Gd_{0.8})_3Al_5O_{12}:Ce$. 100 pieces of the light emitting diodes of Example 5 were made and measured for various characteristics.

[0181] Measurement of chromaticity point gave values of (0.450, 0.420) in average for chromaticity point (x, y), and light of incandescent lamp color was emitted. Fig. 19A, Fig. 19B and Fig. 19C show the emission spectra of the phosphor, the light emitting component and the light emitting diode of Example 5, respectively. Although the light emitting diodes of Example 5 showed luminance about 40% lower than that of the light emitting diodes of Example 5, showed good weatherability comparable to that of Example 1 in life test.

(Example 6)

[0182] The light emitting diode of Example 6 was made in the same manner as in Example 1 except for using phosphor represented by general formula $Y_3Al_5O_{12}:Ce$. 100 pieces of the light emitting diodes of Example 6 were made and measured for various characteristics.

[0183] Measurement of chromaticity point slightly yellow-greenish white light compared to Example 1 was emitted. The light emitting diode of Example 6 showed good weatherability similar to that of Example 1 in life test. Fig. 20A, Fig. 20B and Fig. 20C show the emission spectra of the phosphor, the light emitting component and the light emitting diode of Example 6, respectively.

(Example 7)

[0184] The light emitting diode of Example 7 was made in the same manner as in Example 1 except for using phosphor represented by general formula

Y₃(Al_{0.5}Ga_{0.5})₅O₁₂:Ce. 100 pieces of the light emitting diodes of Example 7 were made and measured for various characteristics.

[0185] Although the light emitting diodes of Example 7 showed a low luminance, emitted greenish white light and showed good weatherability similar to that of Example 1 in life test. Fig. 21A, Fig. 21B and Fig. 21C show the emission spectra of the phosphor, the light emitting component and the light emitting diode of Example 7, respectively.

(Example 8)

[0186] The light emitting diode of Example 8 was made in the same manner as in Example 1 except for using phosphor represented by general formula Gd₃(Al_{0.5}Ga_{0.5})₅O₁₂:Ce which does not contain Y. 100 pieces of the light emitting diodes of Example 8 were made and measured for various characteristics.

[0187] Although the light emitting diodes of Example 8 showed a low luminance, showed good weatherability similar to that of Example 1 in life test.

(Example 9)

[0188] Light emitting diode of Example 9 is planar light emitting device having the configuration shown in Fig. 7.

[0189] In 0.05Ga_{0.95}N semiconductor having emission peak at 450nm is used as a light emitting component. Light emitting components are made by flowing TMG (trimethyl gallium) gas, TMI (trimethyl indium) gas, nitrogen gas and dopant gas together with a carrier gas on a cleaned sapphire substrate and forming a gallium nitride compound semiconductor layer in MOCVD process. A gallium nitride semiconductor layer having N type conductivity and a gallium nitride semiconductor layer having P type conductivity are formed by switching SiH₄ and Cp₂Mg as dopant gas, thereby forming a PN junction. For the semiconductor light emitting component, a contact layer which is gallium nitride semiconductor having N type conductivity, a clad layer which is gallium

nitride aluminum semiconductor having N type conductivity, a clad layer which is gallium nitride aluminum semiconductor having P type conductivity and a contact layer which is gallium nitride semiconductor having P type conductivity are formed. An activation layer of Zn-doped InGaN which makes a double-hetero junction is formed between the clad layer having N type conductivity and the clad layer having P type conductivity. A buffer layer is provided on the sapphire substrate by forming gallium nitride semiconductor layer at a low temperature. The P type nitride semiconductor layer is annealed at a temperature of 400°C or above after forming the film.

[0190] After forming the semiconductor layers and exposing the surfaces of P type and N type semiconductor layers by etching, electrodes are formed by sputtering. After scribing the semiconductor wafer which has been made as described above, light emitting components are made as light emitting components by dividing the wafer with external force.

[0191] The light emitting component is mounted on a mount lead which has a cup at the tip of a silver-plated copper lead frame, by die bonding with epoxy resin. Electrodes of the light emitting component, the mount lead and the inner lead are electrically connected by wire bonding with gold wires having a diameter of 30µm.

[0192] The lead frame with the light emitting component attached thereon is placed in a bullet-shaped die and sealed with translucent epoxy resin for molding, which is then cured at 150°C for 5 hours, thereby to form a blue light emitting diode. The blue light emitting diode is connected to one end face of an acrylic optical guide plate which is polished on all end faces. On one surface and side face of the acrylic plate, screen printing is applied by using barium titanate dispersed in an acrylic binder as white color reflector, which is then cured.

[0193] Phosphor of green and red colors are made by dissolving rare earth elements of Y, Gd, Ce and La in acid in stoichiometrical proportions, and coprecipitating the solution with oxalic acid. Oxide of the coprecipitate obtained by firing this material

is mixed with aluminum oxide and gallium oxide, thereby to obtain respective mixture materials. The mixture is then mixed with ammonium fluoride used as a flux, and fired in a crucible at a temperature of 1400 °C in air for 3 hours. Then the fired material is ground by a ball mill in water, washed, separated, dried and sieved thereby to obtain the desired material.

[0194] 120 parts by weight of the first fluorescent material having a composition of $Y_3(Al_{0.6}Ga_{0.4})_5O_{12}:Ce$ and capable of emitting green light prepared as described above and 100 parts by weight of the second fluorescent material having a composition of $(Y_{0.4}Gd_{0.6})_3Al_5O_{12}:Ce$ and capable of emitting red light prepared in a process similar to that for the first fluorescent material, are sufficiently mixed with 100 parts by weight of epoxy resin, to form a slurry. The slurry is applied uniformly onto an acrylic layer having a thickness of 0.5 mm by means of a multi-coater, and dried to form a fluorescent material layer to be used as a color converting material having a thickness of about 30 μ m. The fluorescent material layer is cut into the same size as that of the principal light emitting plane of the optical guide plate, and arranged on the optical guide plate thereby to form the planar light emitting device. Measurements of chromaticity point and color rendering index of the light emitting device gave values of (0.29, 0.34) for chromaticity point (x, y) and 92.0 for color rendering index (Ra) which are approximate to the properties of 3-waveform fluorescent lamp. Light emitting efficiency of 12 lm/W comparable to that of an incandescent lamp was obtained. Further in weatherability tests under conditions of energization with a current of 60mA at room temperature, 20mA at room temperature and 20mA at 60°C with 90% RH, no change due to the fluorescent material was observed.

(Comparative Example 2)

[0195] Forming of light emitting diode and weatherability tests thereof were conducted in the same manner as in Example 9 except for mixing the same quantities of a

green organic fluorescent pigment (FA-001 of Synleuch Chemisch) and a red organic fluorescent pigment (FA-005 of Synleuch Chemisch) which are perylene-derivatives, instead of the first fluorescent material represented by general formula $Y_3(Al_{0.6}Ga_{0.4})_5O_{12}:Ce$ capable of emitting green light and the second fluorescent material represented by general formula $(Y_{0.4}Gd_{0.6})_3Al_5O_{12}:Ce$ capable of emitting red light of Example 9. Chromaticity coordinates of the light emitting diode of Comparative Example 1 thus formed were $(x, y) = (0.34, 0.35)$. Weatherability test was conducted by irradiating with ultraviolet ray generated by carbon arc for 200 hours, representing equivalent irradiation of sun light over a period of one year, while measuring the luminance retaining ratio and color tone at various times during the test period. In a reliability test, the light emitting component was energized to emit light at a constant temperature of 70°C while measuring the luminance and color tone at different times. The results are shown in Fig. 14 and Fig. 15, together with Example 9. As will be clear from Fig. 14 and Fig. 15, the light emitting component of Example 9 experiences less deterioration than Comparative Example 2.

(Example 10)

[0196] The light emitting diode of Example 10 is a lead type light emitting diode.

[0197] In the light emitting diode of Example 10, the light emitting component having a light emitting layer of $In_{0.05}Ga_{0.95}N$ with emission peak at 450nm which is made in the same manner as in Example 9 is used. The light emitting component is mounted in the cup provided at the tip of a silver-plated copper mount lead, by die bonding with epoxy resin. Electrodes of the light emitting component, the mount lead and the inner lead were electrically connected by wire bonding with gold wires.

[0198] Phosphor is made by mixing a first fluorescent material represented by general formula $Y_3(Al_{0.5}Ga_{0.5})_5O_{12}:Ce$ capable of emitting green light and a second fluorescent material represented by general formula $(Y_{0.2}Gd_{0.8})_3Al_5O_{12}:Ce$ capable of

emitting red light prepared as follows. Namely, rare earth elements of Y, Gd and Ce are solved in acid in stoichiometrical proportions, and coprecipitating the solution with oxalic acid. Oxide of the coprecipitation obtained by firing it is mixed with aluminum oxide and gallium oxide, thereby to obtain respective mixture materials. The mixture is mixed with ammonium fluoride used as a flux, and fired in a crucible at a temperature of 1400°C in air for 3 hours. Then, the fired material is ground by a ball mill in water, washed, separated, dried and sieved thereby to obtain the first and second fluorescent materials of the specified particle size distribution.

[0199] 40 parts by weight of the first fluorescent material, 40 parts by weight of the second fluorescent material and 100 parts by weight of epoxy resin are sufficiently mixed to form a slurry. The slurry is poured into the cup which is provided on the mount lead wherein the light emitting component is placed. Then the resin including the phosphor is cured at 130°C for 1 hour. Thus a coating layer including the phosphor in thickness of 120µm is formed on the light emitting component. Concentration of the phosphor in the coating layer is increased gradually toward the light emitting component. Further, the light emitting component and the phosphor are sealed by molding with translucent epoxy resin for the purpose of protection against extraneous stress, moisture and dust. A lead frame with the coating layer of phosphor formed thereon is placed in a bullet-shaped die and mixed with translucent epoxy resin and then cured at 150°C for 5 hours. Under visual observation of the light emitting diode formed as described above in the direction normal to the light emitting plane, it was found that the central portion was rendered yellowish color due to the body color of the phosphor.

[0200] Measurements of chromaticity point, color temperature and color rendering index of the light emitting diode of Example 10 which was made as described above gave values of (0.32, 0.34) for chromaticity point (x, y), 89.0 for color rendering index (Ra) and light emitting efficiency of 10 lm/W. Further in weatherability tests under conditions of energization with a current of 60mA at room temperature, 20mA at room

temperature and 20mA at 60°C with 90% RH, no change due to the phosphor was observed, showing no difference from an ordinary blue light emitting diode in the service life characteristic.

(Example 11)

[0201] In_{0.4}Ga_{0.6}N semiconductor having an emission peak at 470nm is used as an LED element. Light emitting components are made by flowing TMG (trimethyl gallium) gas, TMI (trimethyl indium) gas, nitrogen gas and dopant gas together with a carrier gas on a cleaned sapphire substrate thereby to form a gallium nitride compound semiconductor layer in the MOCVD process. A gallium nitride semiconductor layer having N type conductivity and a gallium nitride semiconductor layer having P type conductivity were formed by switching SiH₄ and Cp₂Mg used as the dopant gas, thereby forming a PN junction. For the LED element, a contact layer which is gallium nitride semiconductor having N type conductivity, a clad layer which is gallium nitride aluminum semiconductor having P type conductivity and a contact layer which is gallium nitride semiconductor having P type conductivity are formed. An activation layer of non-doped InGa_{0.4}N with thickness of about 3nm is formed between the contact layer having N type conductivity and the clad layer having P type conductivity, thereby to make single quantum well structure. A buffer layer is provided on the sapphire substrate by forming a gallium nitride semiconductor layer at a low temperature.

[0202] After forming the layers and exposing the surfaces of P type and N type semiconductor layers by etching, electrodes are formed by sputtering. After scribing the semiconductor wafer which is made as described above, light emitting components are made by dividing the wafer with an external force.

[0203] The light emitting component is mounted in a cup at the tip of a silver-plated copper mount lead by die bonding with epoxy resin. Electrodes of the light

emitting component, the mount lead and the inner lead are electrically connected by wire bonding with gold wires having a diameter of 30 μ m.

[0204] The lead frame with the light emitting component attached thereon is placed in a bullet-shaped die and sealed with translucent epoxy resin for molding, which is then cured at 150°C for 5 hours, thereby to form a blue light emitting diode. The blue light emitting diode is connected to one end face of an acrylic optical guide plate which is polished on all end faces. On one surface and side face of the acrylic plate, screen printing is applied by using barium titanate dispersed in an acrylic binder as white color reflector, which is then cured.

[0205] Phosphor is made by mixing a fluorescent material represented by general formula (Y_{0.8}Gd_{0.2})₃Al₅O₁₂:Ce capable of emitting yellow light of relatively short wavelength and a fluorescent material represented by general formula (Y_{0.4}Gd_{0.6})₃Al₅O₁₂:Ce capable of emitting yellow light of relatively long wavelength prepared as follows. Namely, rare earth elements of Y, Gd and Ce are solved in acid in stoichiometrical proportions, and coprecipitating the solution with oxalic acid. Oxide of the coprecipitation obtained by firing it is mixed with aluminum oxide, thereby to obtain respective mixture material. The mixture is mixed with ammonium fluoride used as a flux, and fired in a crucible at a temperature of 1400°C in air for 3 hours. Then the fired material is ground by a ball mill in water, washed, separated, dried and sieved.

[0206] 100 parts by weight of yellow fluorescent material of relatively short wavelength and 100 parts by weight of yellow fluorescent material of relatively long wavelength which are made as described above are sufficiently mixed with 1000 parts by weight of acrylic resin and extruded, thereby to form a fluorescent material film to be used as color converting material of about 180 μ m in thickness. The fluorescent material film is cut into the same size as the principal emission plane of the optical guide plate and arranged on the optical guide plate, thereby to make a light emitting device. Measurements of chromaticity point and color rendering index of the light emitting

device of Example 3 which is made as described above gave values of (0.33, 0.34) for chromaticity point (x, y), 88.0 for color rendering index (Ra) and light emitting efficiency of 101 m/W. Fig. 22A, Fig. 22B and Fig. 22C show emission spectra of the fluorescent material represented by $(Y_{0.8}Gd_{0.2})_3Al_5O_{12}:Ce$ and a fluorescent material represented by general formula $(Y_{0.4}Gd_{0.6})_3Al_5O_{12}:Ce$ used in Example 11. Fig. 23 shows emission spectrum of the light emitting diode of Example 11. Further in life tests under conditions of energization with a current of 60mA at room temperature, 20mA at room temperature and 20mA at 60°C with 90% RH, no change due to the fluorescent material was observed. Similarly, desired chromaticity can be maintained even when the wavelength of the light emitting component is changed by changing the content of the fluorescent material.

(Example 12)

[0207] The light emitting diode of Example 12 was made in the same manner as in Example 1 except for using phosphor represented by general formula $Y_3In_5O_{12}:Ce$. 100 pieces of the light emitting diode of Example 12 were made. Although the light emitting diode of Example 12 showed luminance lower than that of the light emitting diodes of Example 1, showed good weatherability comparable to that of Example 1 in life test.

[0208] As described above, the light emitting diode of the present invention can emit light of a desired color and is subject to less deterioration of emission efficiency and good weatherability even when used with high luminance for a long period of time. Therefore, application of the light emitting diode is not limited to electronic appliances but can open new applications including display for automobile, aircraft and buoys for harbors and ports, as well as outdoor use such as sign and illumination for expressways.

CLAIMS:

1. A light emitting diode comprising:
 - an LED chip having an electrode;
 - a transparent material covering said LED chip, and
 - a phosphor contained in said transparent material and absorbing a part of light emitted by said LED chip and emitting light of wavelength different from that of the absorbed light;wherein the main emission peak of said LED chip is within the range from 400 nm to 530 nm,
 - a concentration of said phosphor in the vicinity of said LED chip is larger than a concentration of said phosphor in the vicinity of the surface of said transparent material, and
 - said phosphor diffuses the light from said LED chip and suppresses a formation of an emission pattern by a partial blocking of the light by said electrode.

2. The light emitting diode according to claim 1, wherein said LED chip comprises a sapphire substrate.

3. The light emitting diode according to claim 1, wherein said LED chip emits a light having a spectrum with a peak in the range from 420 to 490 nm, said phosphor emits light having a spectrum with a peak in the range from 510 to 600 nm and a tail continuing beyond 700 nm, and said spectrum of the light emitted from said phosphor and said spectrum of the light emitted from said LED chip overlap with each other to make a continuous combined spectrum.

4. The light emitting diode according to claim 3, wherein said spectrum of the light emitted from said phosphor has a peak in the range from 530 to 570 nm and a tail continuing beyond 700 nm.

5. The light emitting diode according to claim 3, wherein a color of said combined spectrum is white.

6. The light emitting diode according to claim 1, wherein said phosphor comprises two or more kinds of fluorescent materials.

7. The light emitting diode according to claim 1, wherein said phosphor comprises an yttrium-aluminum-garnet fluorescent material containing Y and Al.

8. The light emitting diode according to claim 1, wherein said phosphor has a crystal structure.

9. The light emitting diode according to claim 1, wherein said LED chip comprises a light emitting layer of single quantum well or multi quantum well structure.

10. The light emitting diode according to claim 1, wherein said LED chip comprises InGaN.

11. The light emitting diode according to claim 1, wherein said transparent material is selected from the group consisting of epoxy resin, urea resin, silicone resin and glass.

12. The light emitting diode according to claim 1, wherein said transparent material contains a dispersant.

13. The light emitting diode according to claim 12, wherein said dispersant is selected from the group consisting of barium titanate, titanium oxide, aluminum oxide and silicon dioxide.

14. The light emitting diode according to claim 1, wherein said transparent material contains a color agent.

ABSTRACT OF THE DISCLOSURE

A light emitting device containing a semiconductor light emitting component and a phosphor, the phosphor is capable of absorbing a part of light emitted by the light emitting component and emitting light of a wavelength different from that of the absorbed light, is provided. A straight line connecting a point of chromaticity corresponding to a spectrum generated by the light emitting component and a point of chromaticity corresponding to a spectrum generated by the phosphor is substantially along a black body radiation locus in a chromaticity diagram.

Fig.1

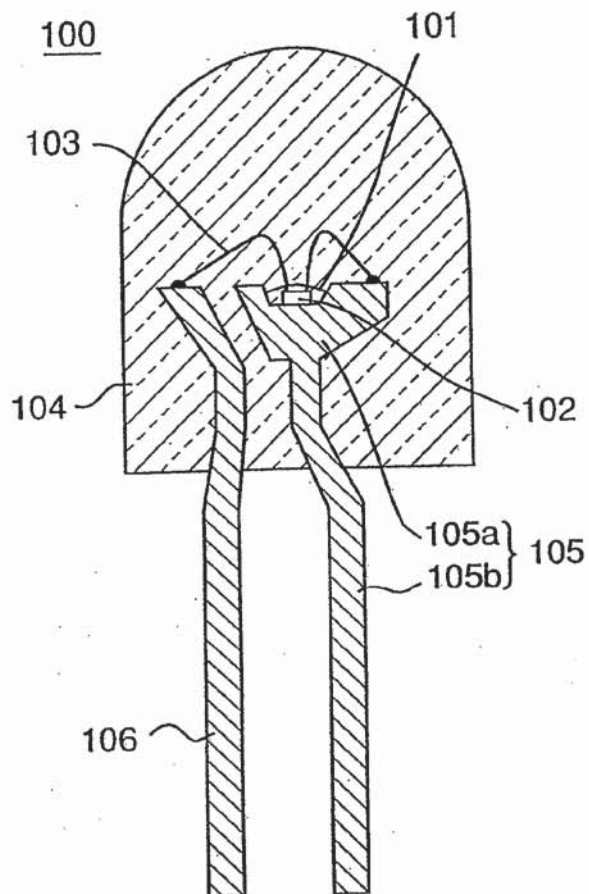

Fig.2

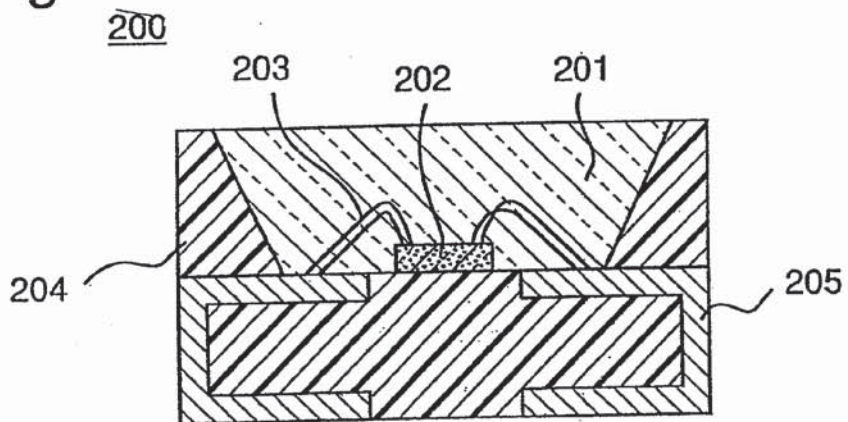

Fig.3A

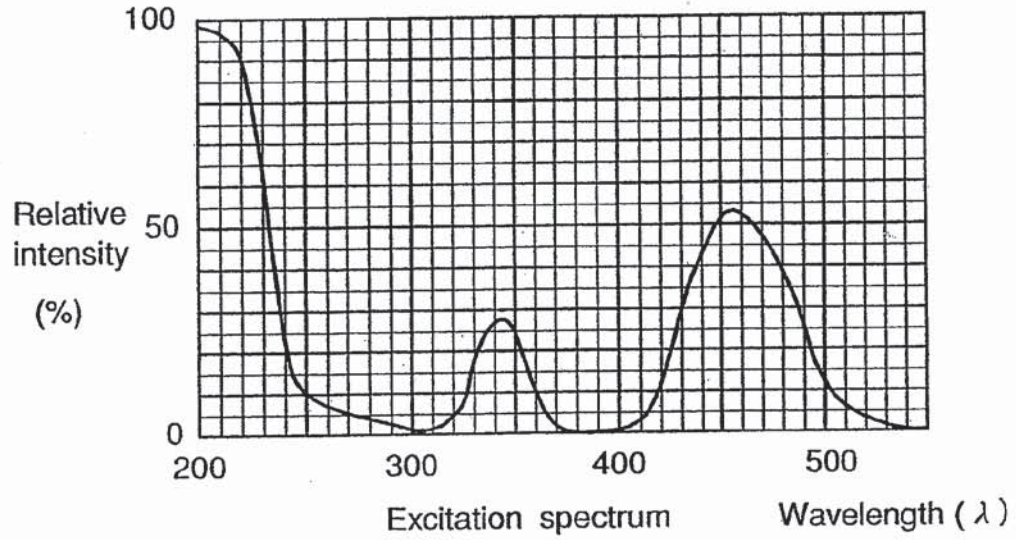

Fig.3B

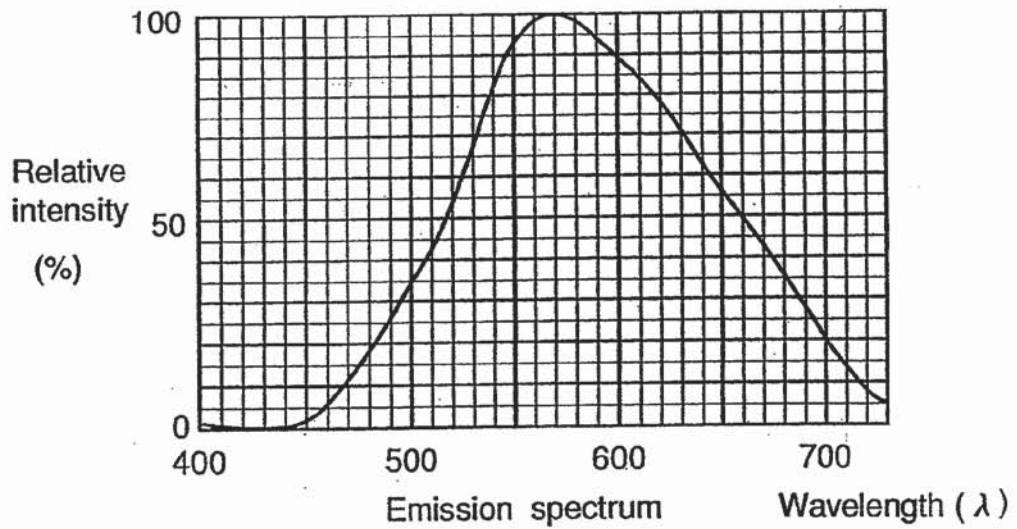

Fig. 4

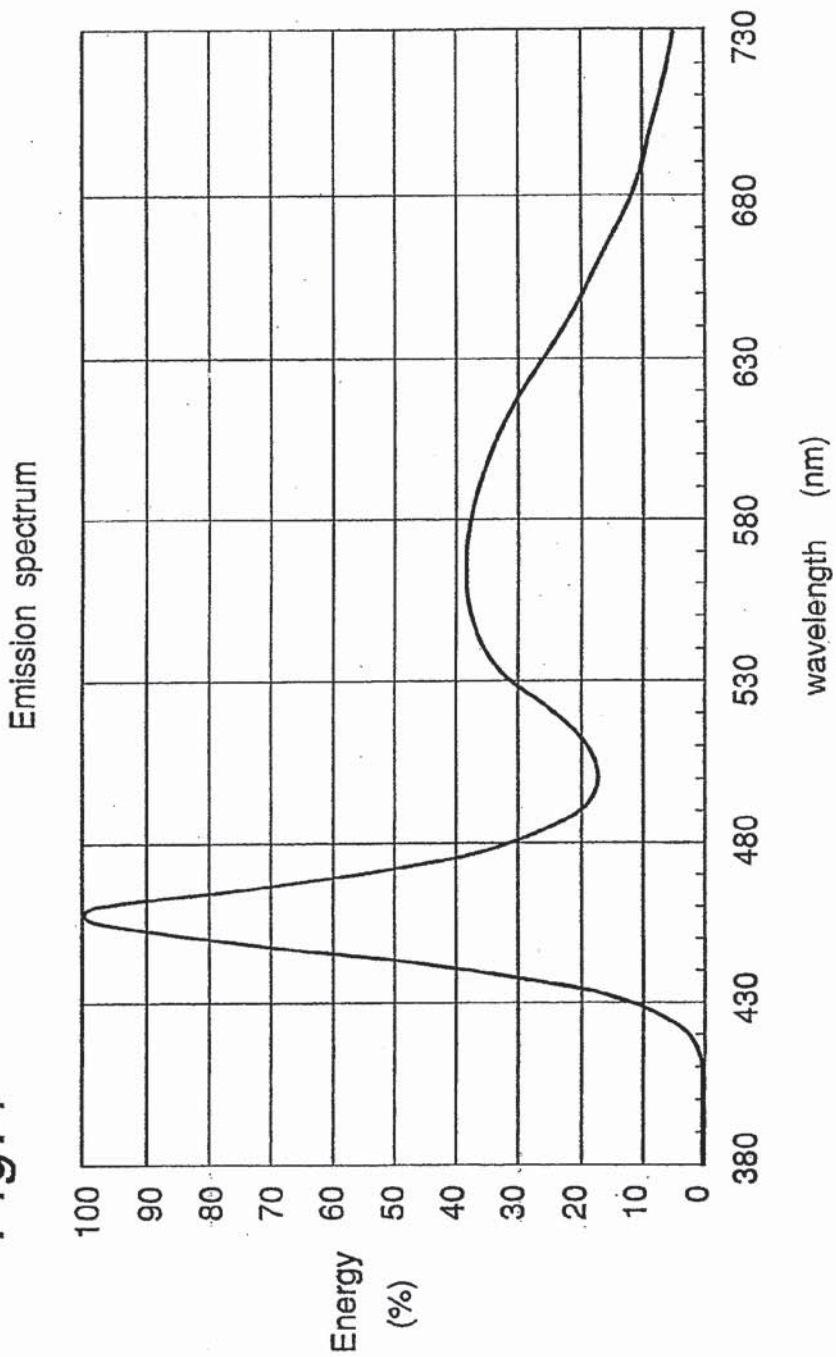

Fig.5A

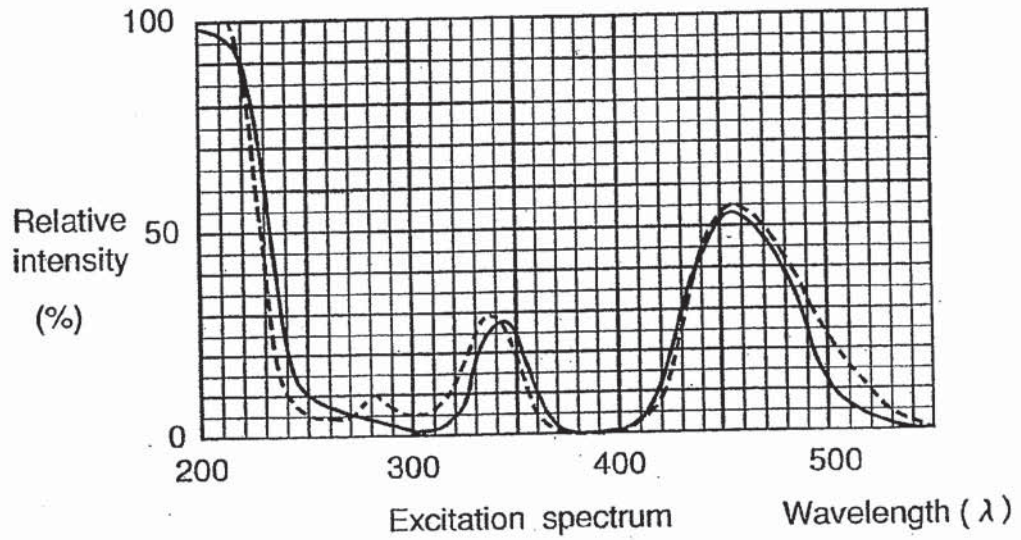

Fig.5B

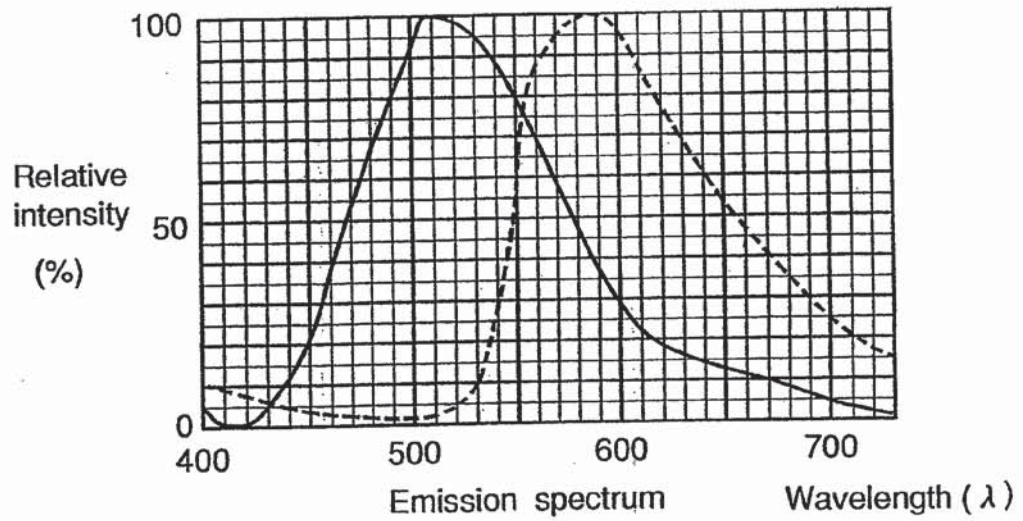

Fig.6

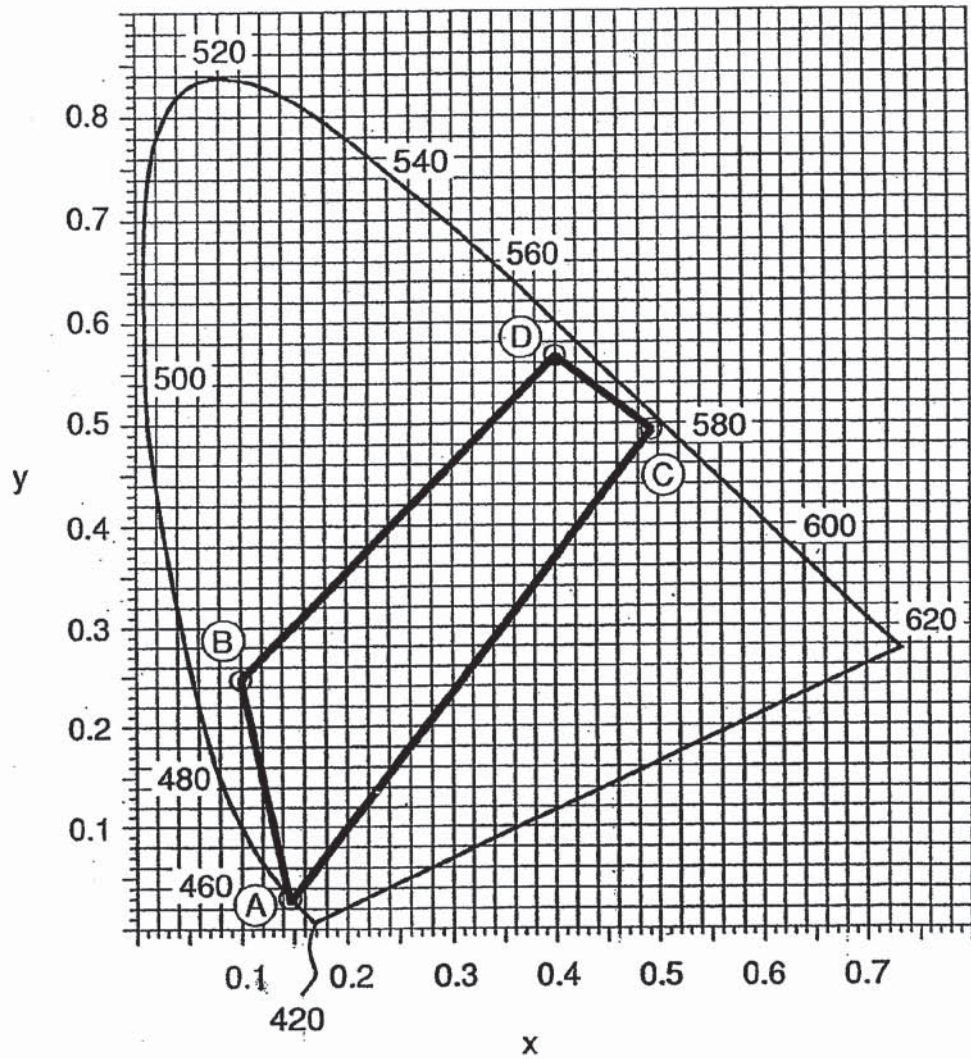

Fig.7

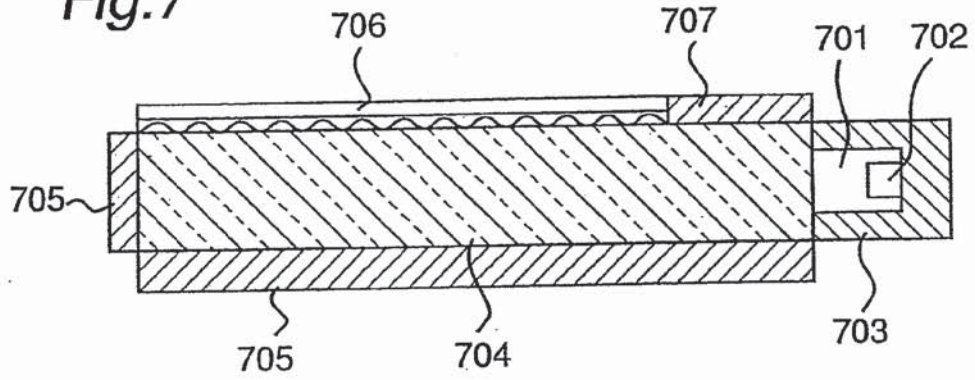

Fig.8

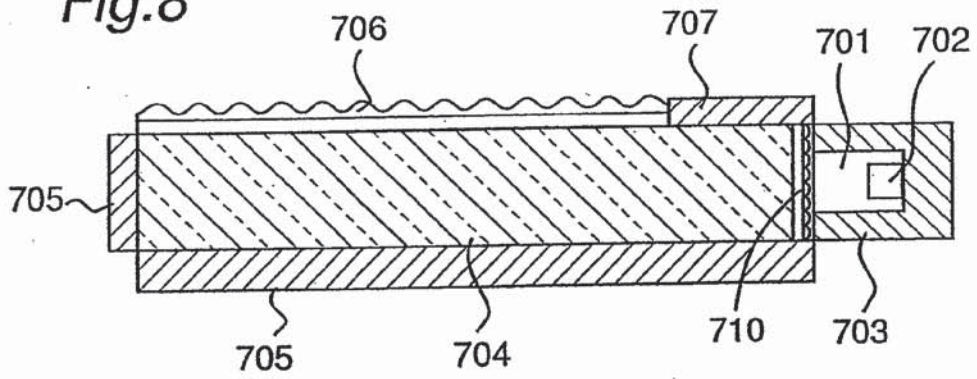

Fig.9

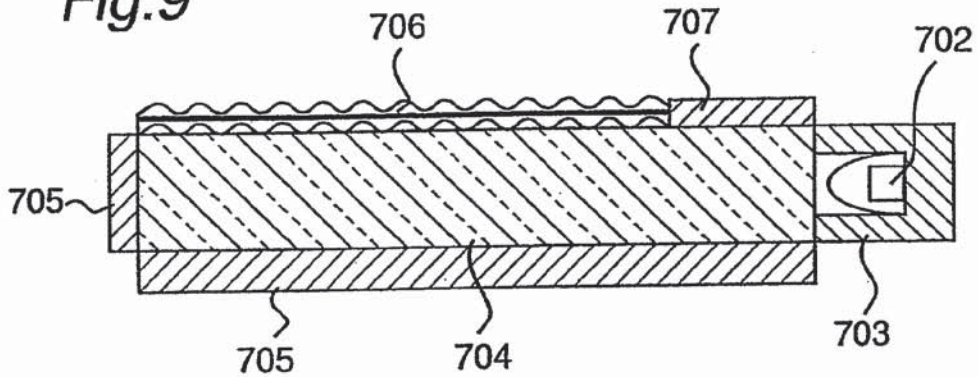

Fig. 10

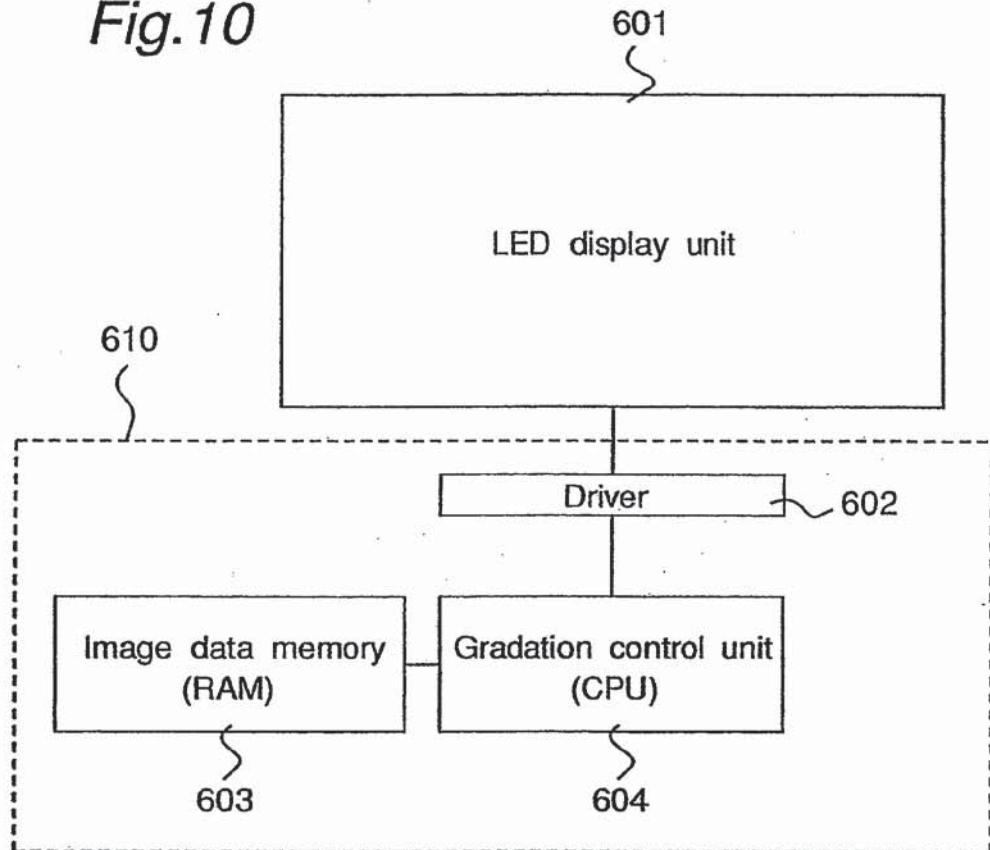

Fig. 11

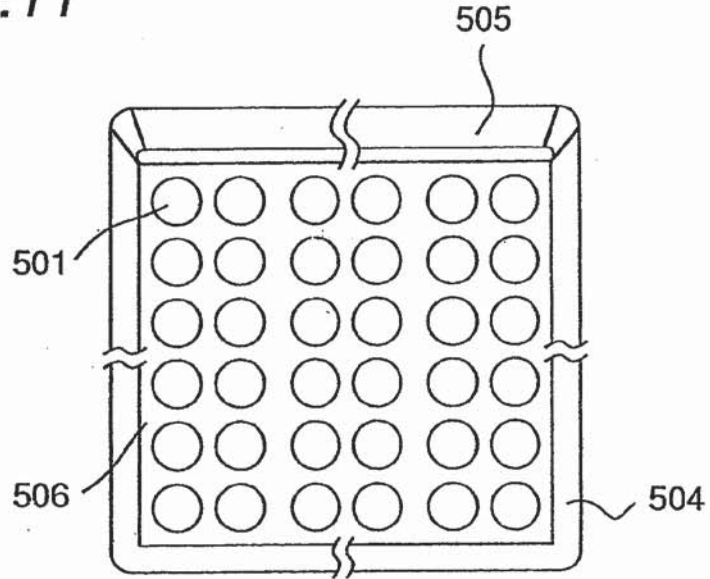

Fig. 12

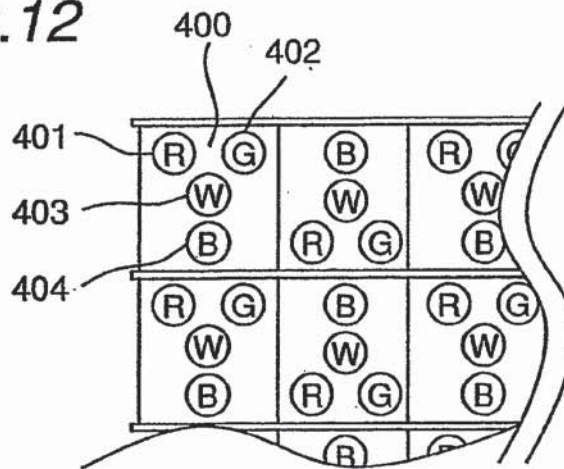

Fig.13A

Life test
If=20mA Ta=25°C

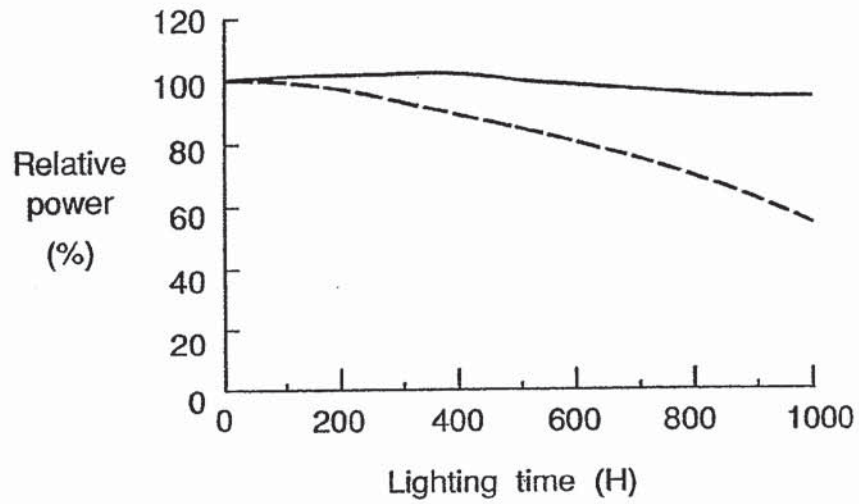

Fig.13B

Life test
If=20mA Ta=60°C 90%RH

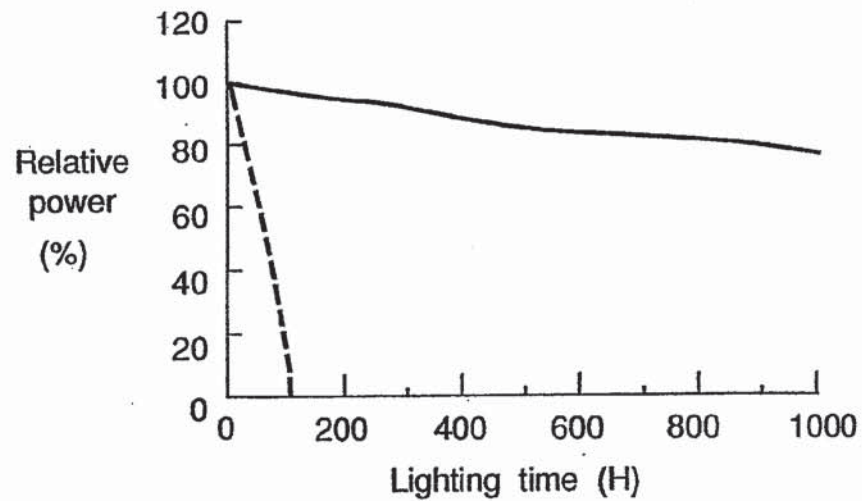

Fig.14A

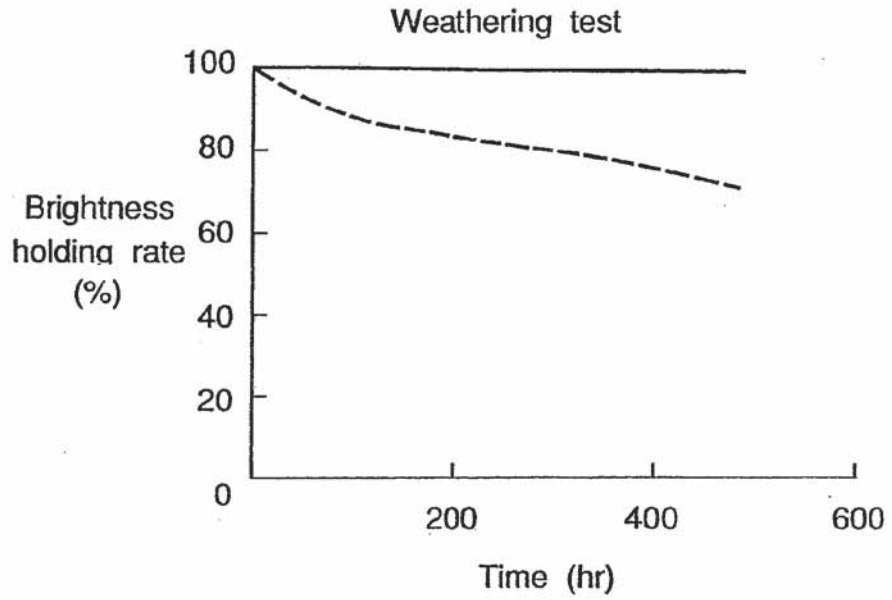

Fig.14B

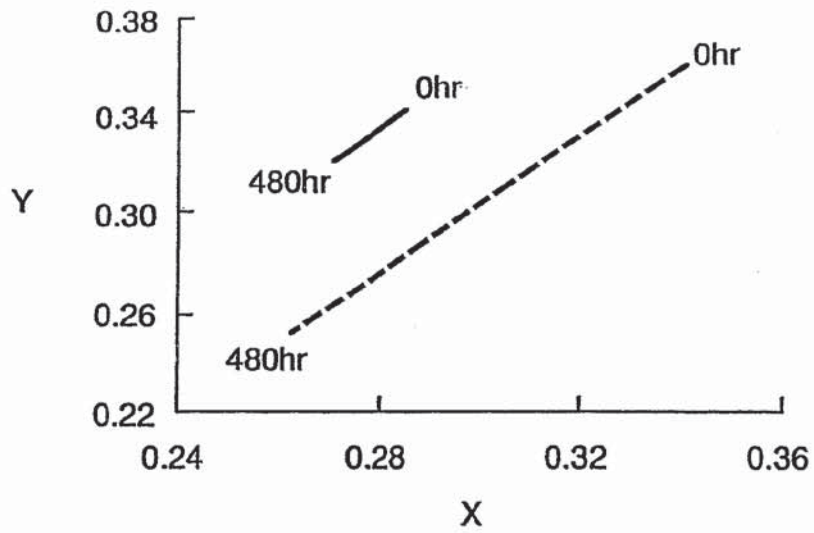

Fig. 15A

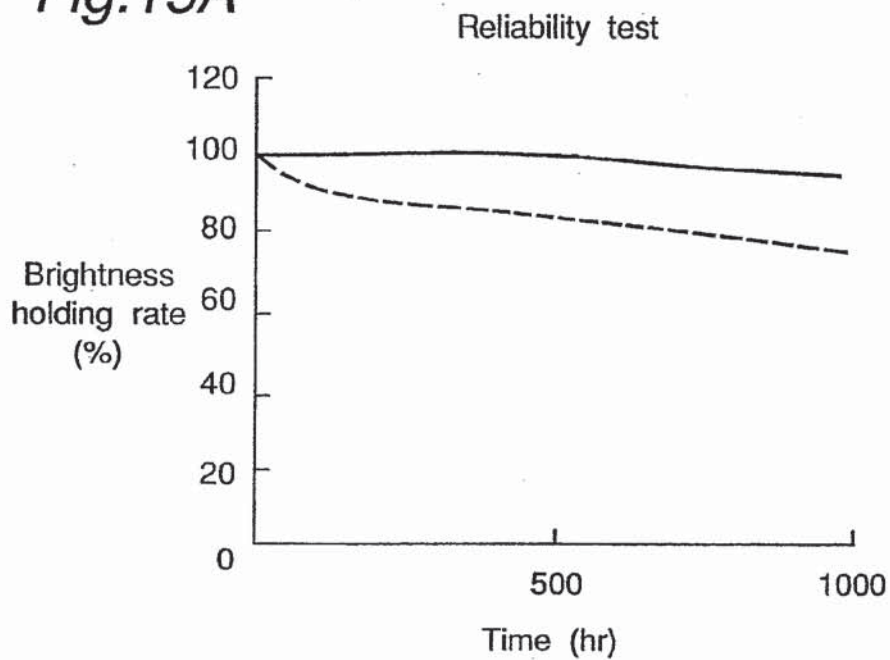

Fig. 15B

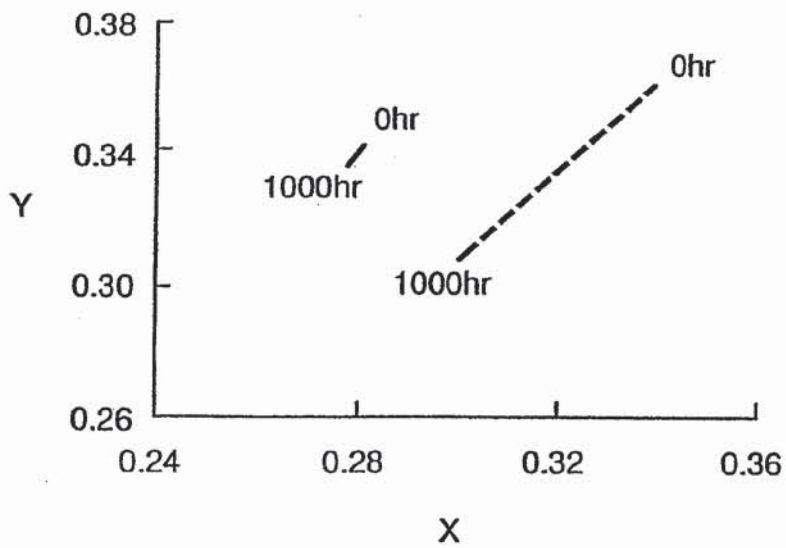

Fig. 16

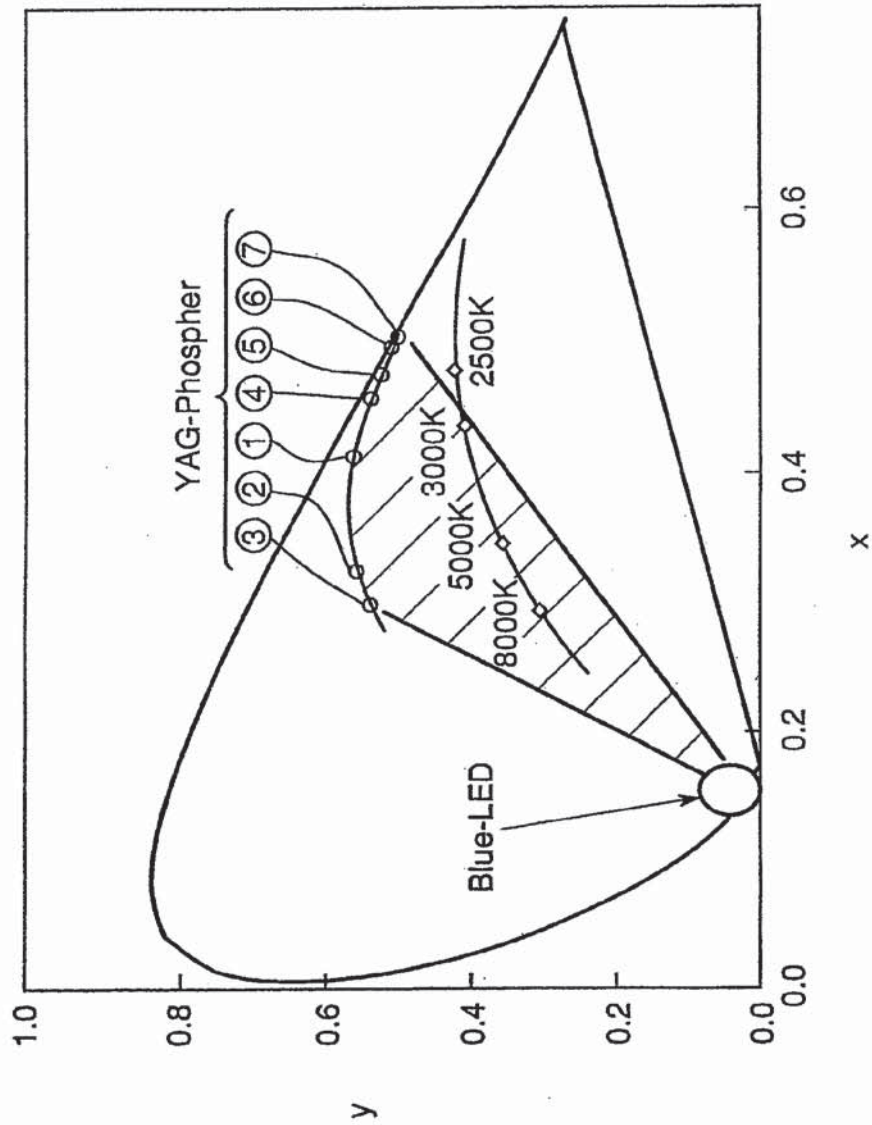

Fig. 17

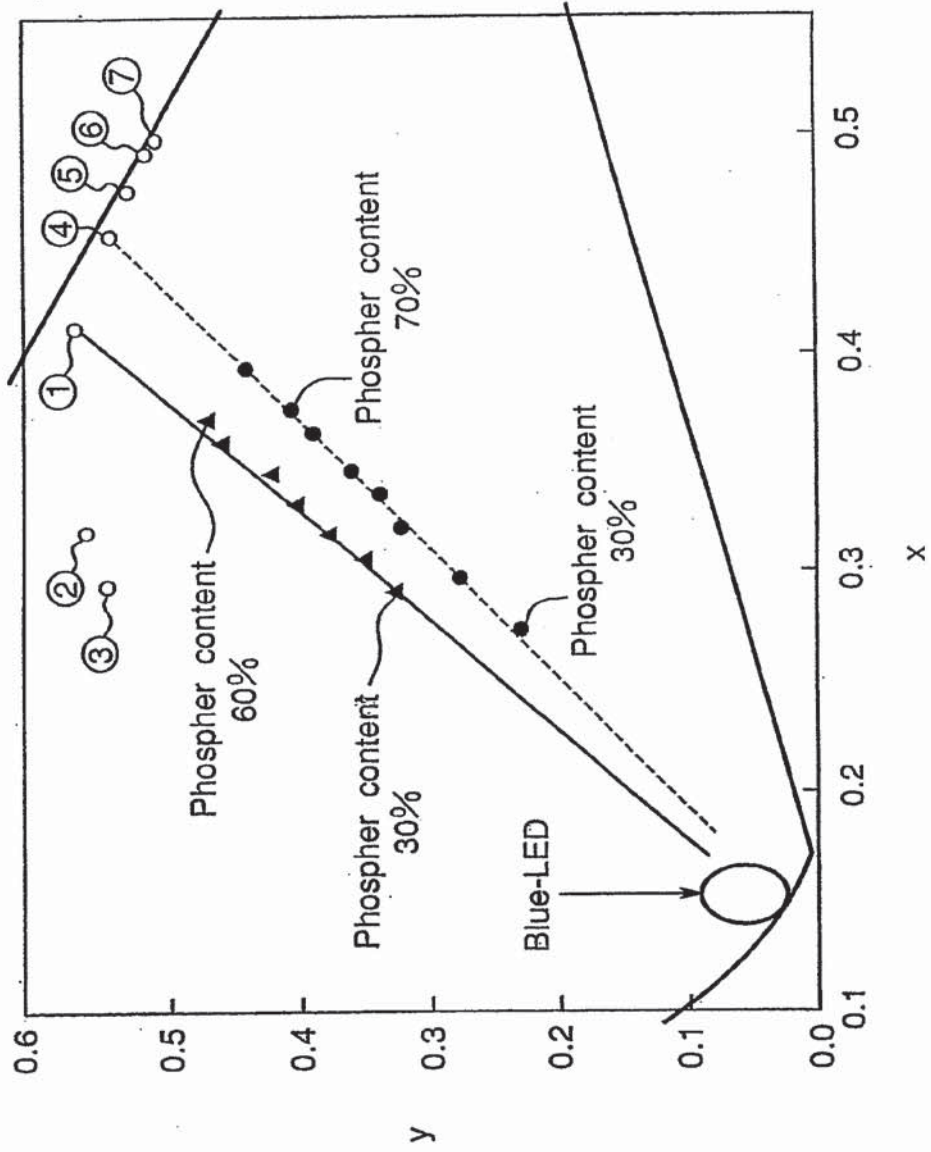

Fig. 18A

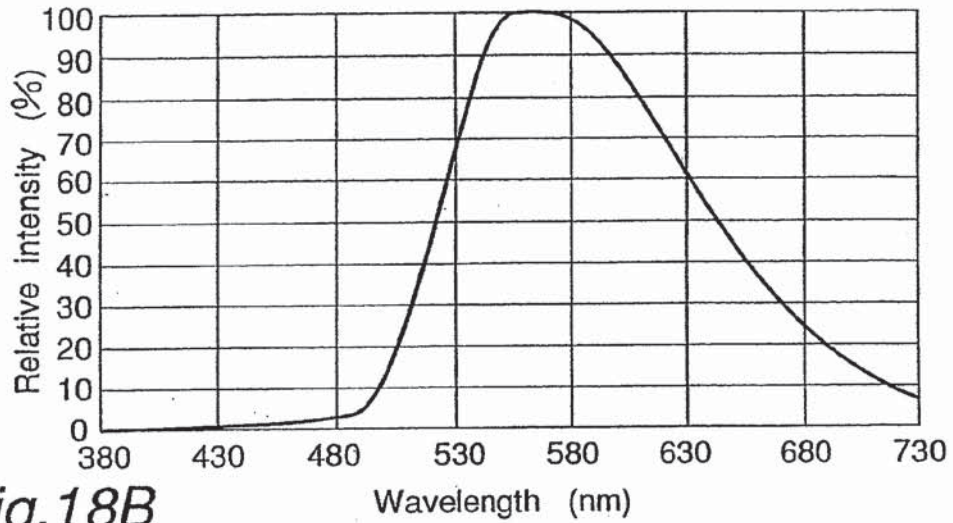

Fig. 18B

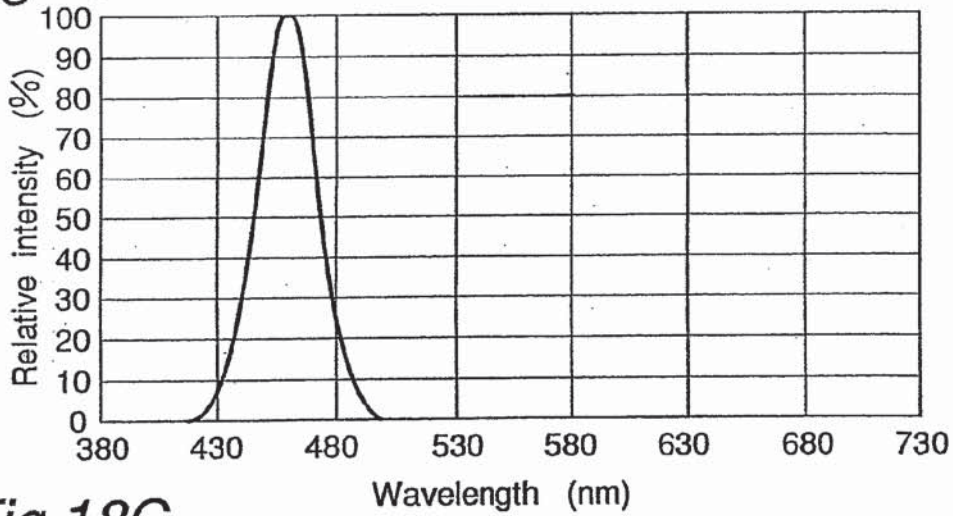

Fig. 18C

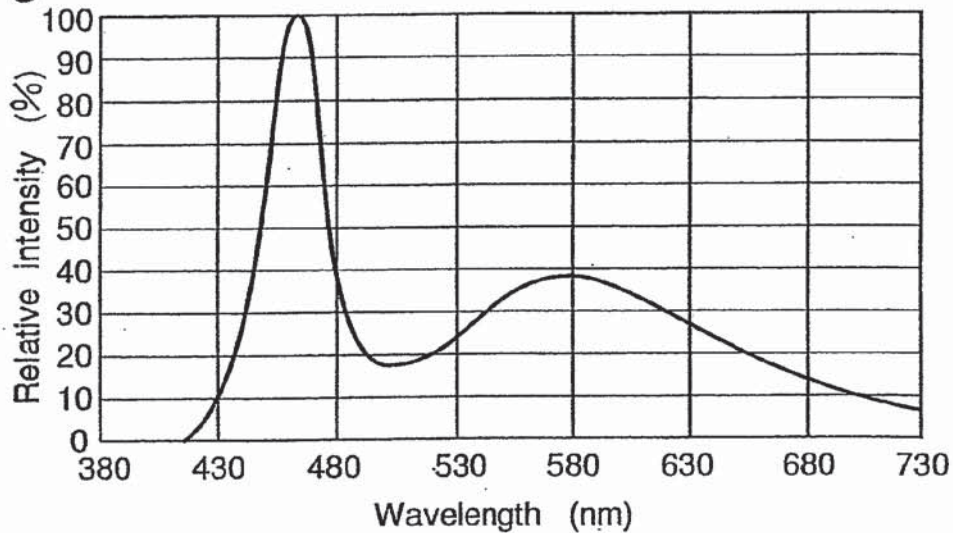

Fig.19A

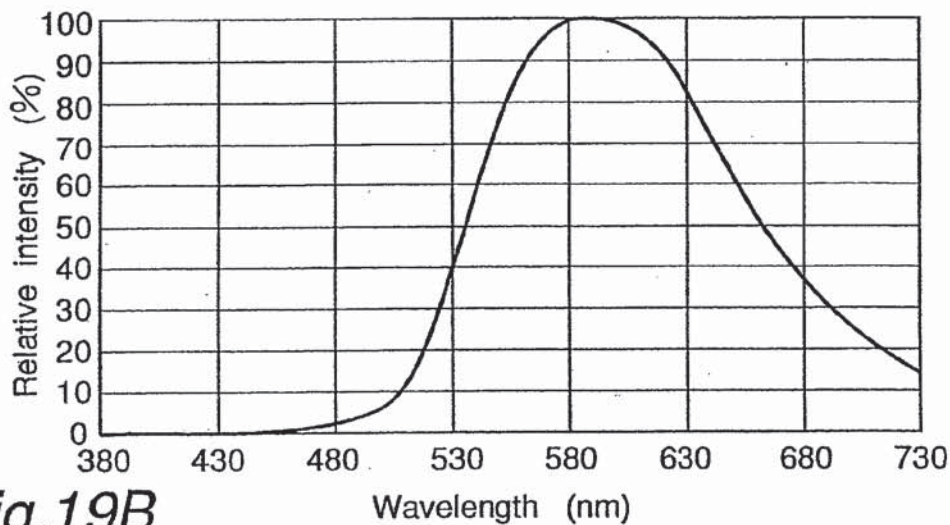

Fig.19B

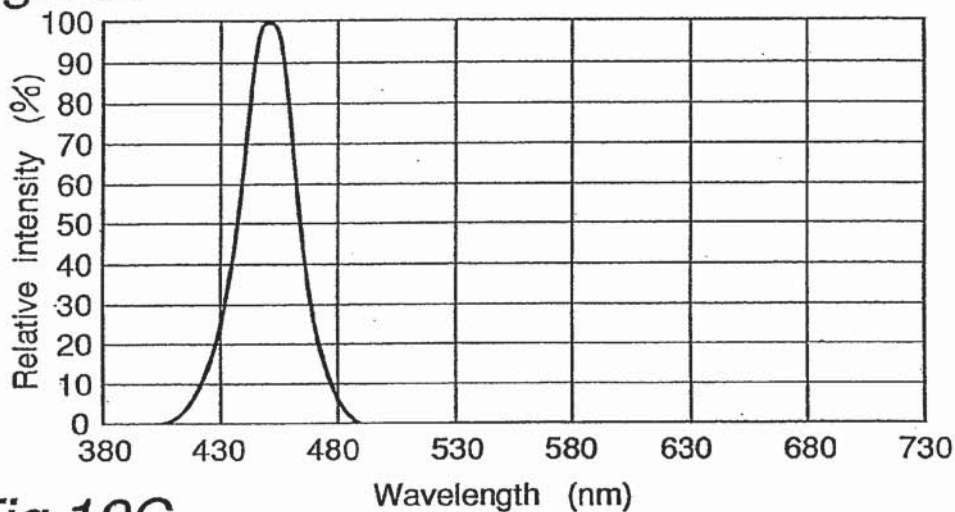

Fig.19C

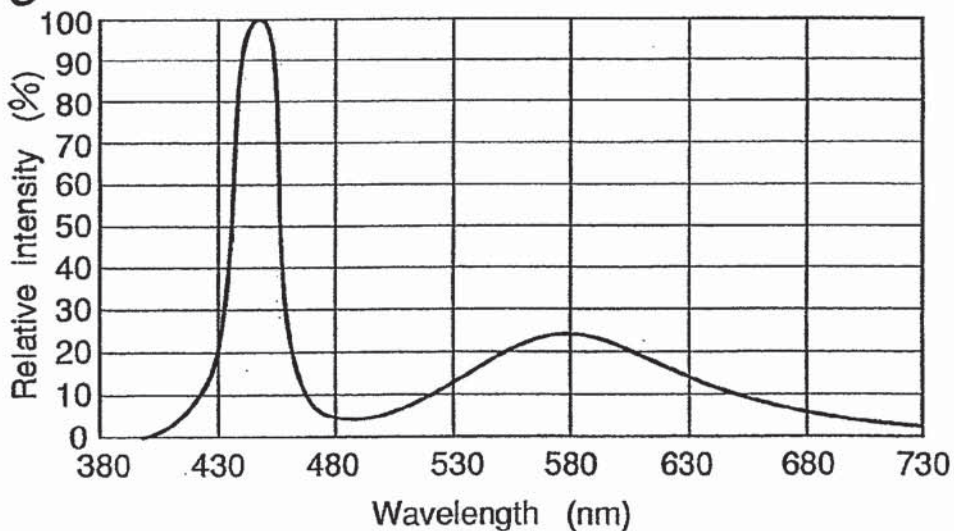

Fig.20A

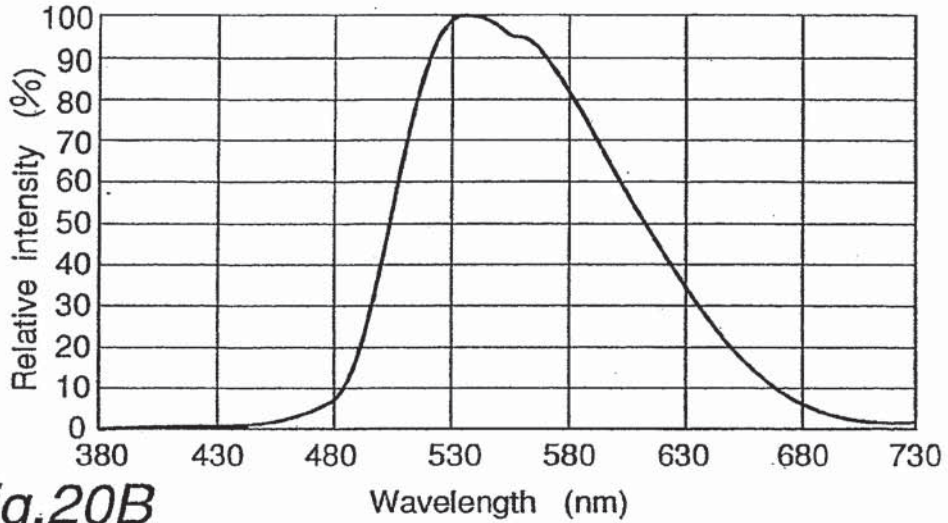

Fig.20B

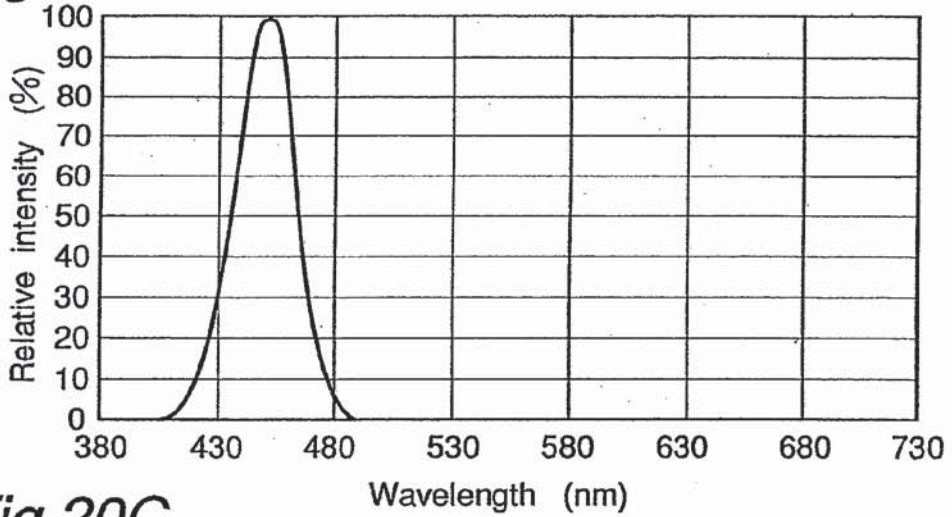

Fig.20C

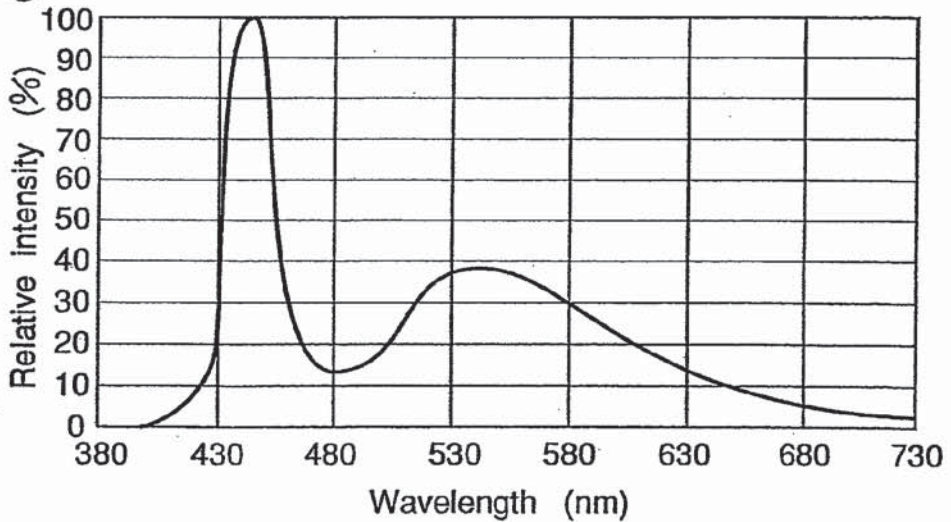

Fig.21A

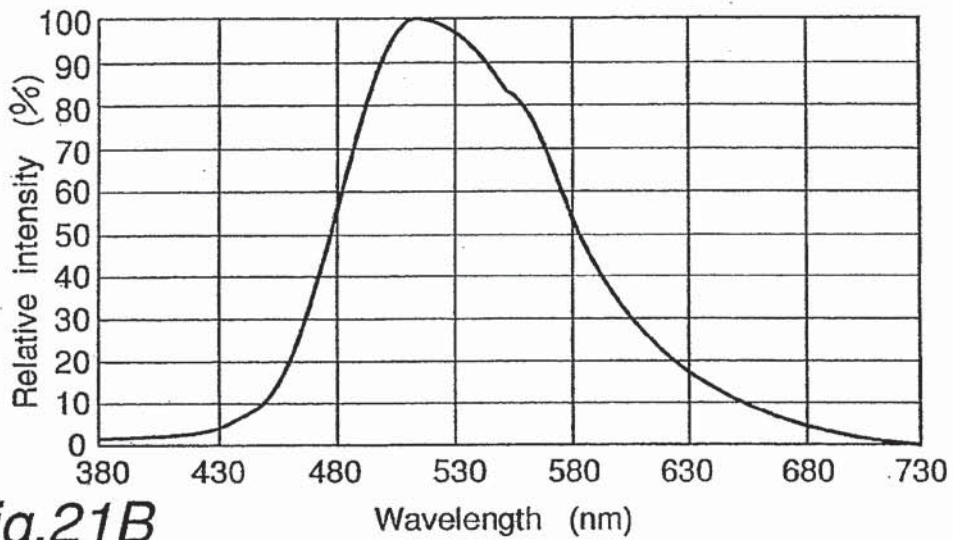

Fig.21B

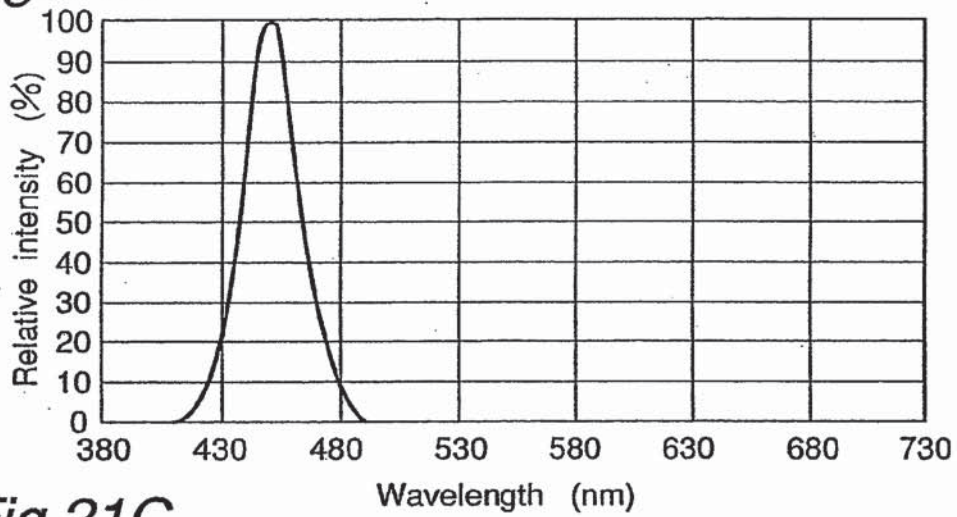

Fig.21C

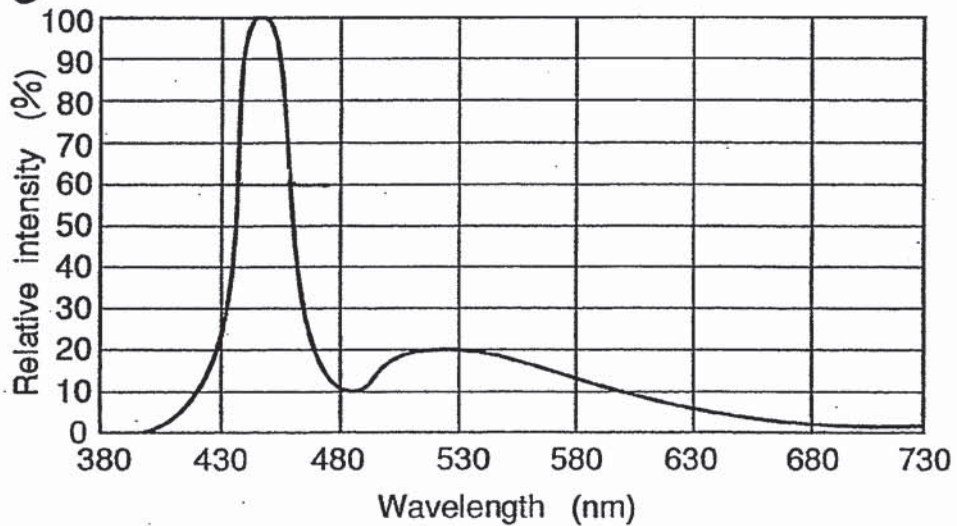

Fig.22A

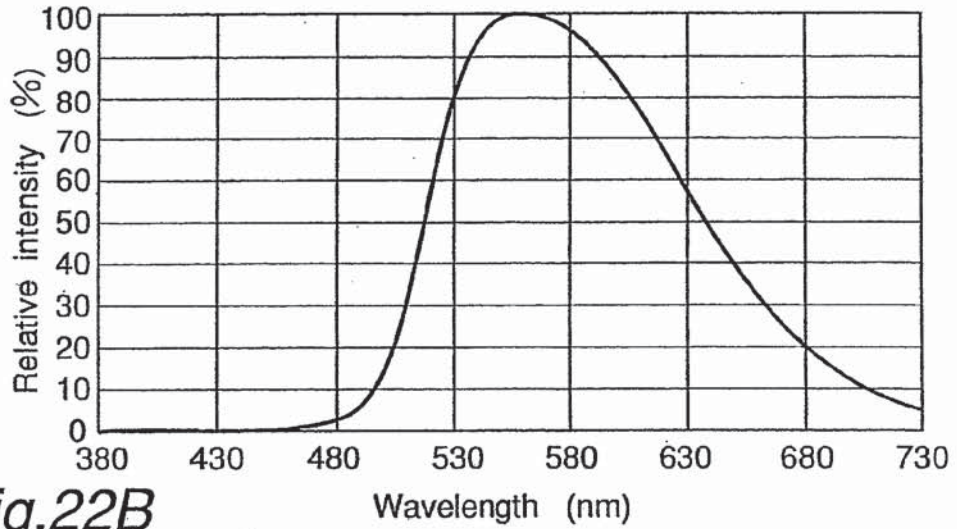

Fig.22B

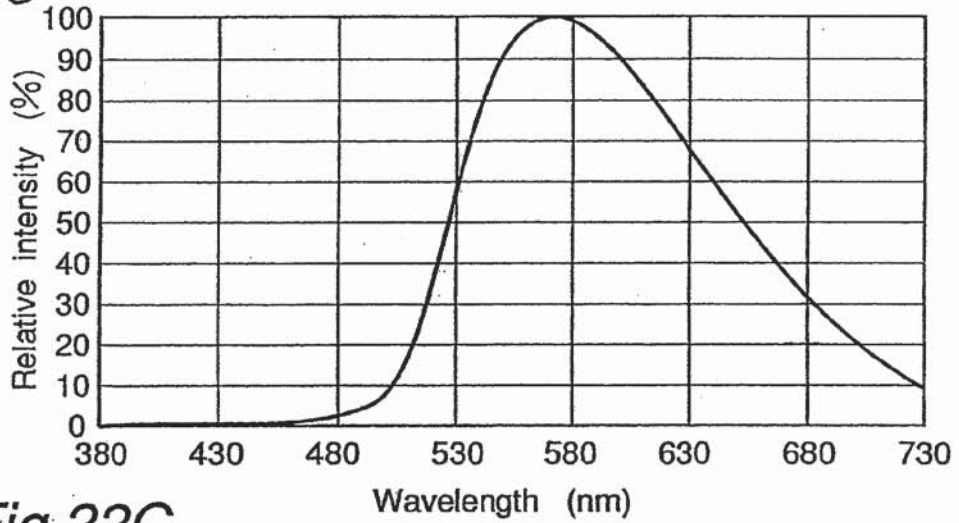

Fig.22C

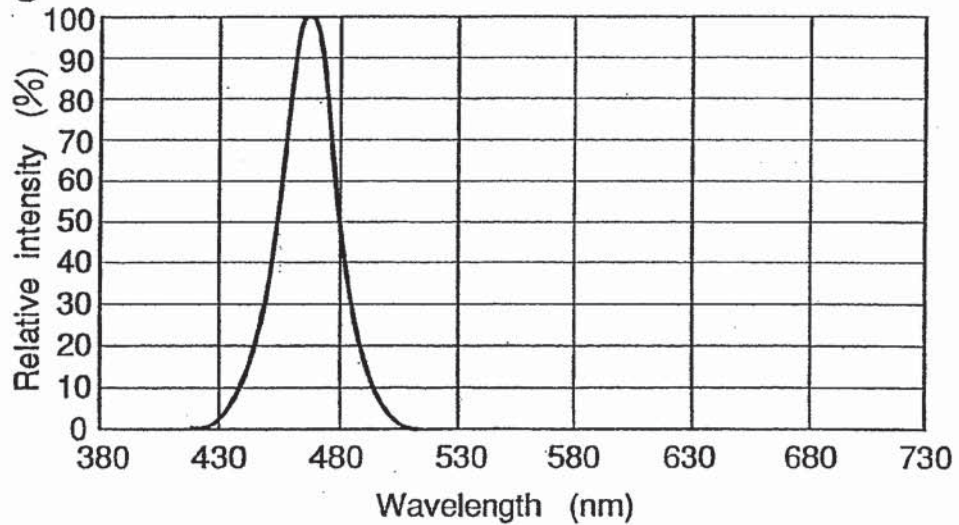
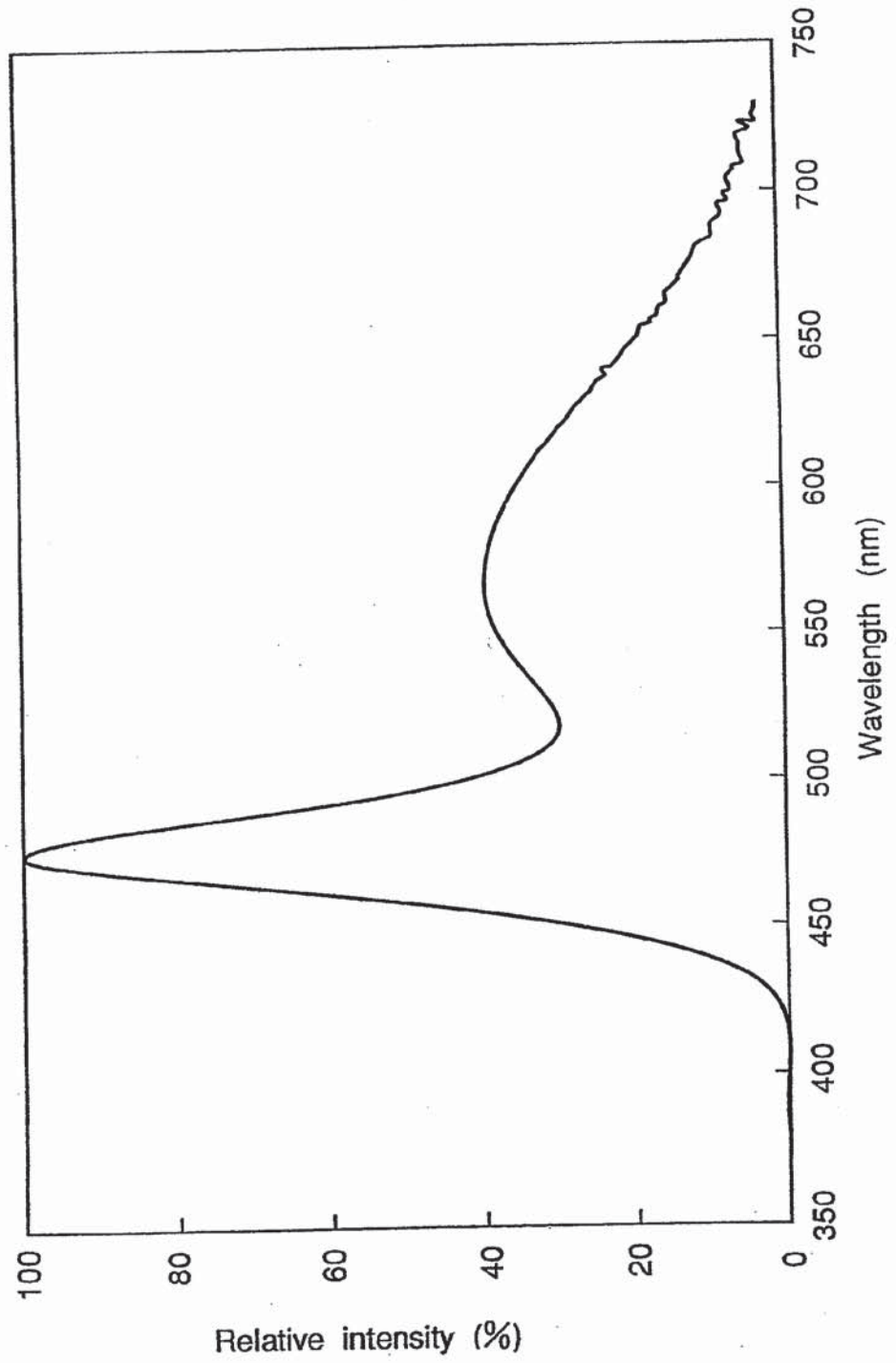

Fig. 23



COMBINED DECLARATION AND POWER OF ATTORNEY FOR PATENT AND DESIGN APPLICATIONS

ATTORNEY DOCKET NO.

20-4260P

PLEASE NOTE: YOU MUST COMPLETE THE FOLLOWING:

As a below named inventor, I hereby declare that: my residence, post office address and citizenship are as stated next to my name; that I verily believe that I am the original, first and sole inventor (if only one inventor is named below) or an original, first and joint inventor (if plural inventors are named below) of the subject matter which is claimed and for which a patent is sought on the invention entitled:*

Insert Title LIGHT EMITTING DEVICE AND DISPLAY

Check Box If Appropriate - For Use Without Specification Attached

the specification of which is attached hereto unless the following box is checked:

[] was filed on ... as United States Application Number ... or PCT International Application Number ... and was amended on ... (if applicable).

I hereby state that I have reviewed and understand the contents of the above identified specification, including the claims, as amended by any amendment referred to above.

I acknowledge the duty to disclose information which is material to patentability as defined in Title 37, Code of Federal Regulations, §1.56.

I do not know and do not believe the same was ever known or used in the United States of America before my or our invention thereof, or patented or described in any printed publication in any country before my or our invention thereof, or more than one year prior to this application, that the same was not in public use or on sale in the United States of America more than one year prior to this application, that the invention has not been patented or made the subject of an inventor's certificate issued before the date of this application in any country foreign to the United States of America on an application filed by me or my legal representatives or assigns more than twelve months (six months for designs) prior to this application, and that no application for patent or inventor's certificate on this invention has been filed in any country foreign to the United States of America prior to this application by me or my legal representatives or assigns, except as follows.

I hereby claim foreign priority benefits under Title 35, United States Code, §119 (a)-(d) of any foreign application(s) for patent or inventor's certificate listed below and have also identified below any foreign application for patent or inventor's certificate having a filing date before that of the application on which priority is claimed:

Insert Priority Information (if appropriate)

Table with 5 columns: Application Number, Country, Filing Date, Priority Claimed (Yes/No), and another Yes/No column. Rows include P 08-198585, P 08-244339, P 08-245381, P 08-359004, and P 09-081010.

I hereby claim the benefit under Title 35, United States Code, § 119(e) of any United States provisional application(s) listed below.

(Application Number) (Filing Date)

(Application Number) (Filing Date)

All Foreign Applications, if any, for any Patent or Inventor's Certificate Filed More Than 12 Months (6 Months for Designs) Prior To The Filing Date of This Application:

Table with 3 columns: Country, Application No., Date of Filing (Month/Day/Year)

I hereby claim the benefit under Title 35, United States Code, §120 of any United States application(s) listed below and, insofar as the subject matter of each of the claims of this application is not disclosed in the prior United States application in the manner provided by the first paragraph of Title 35, United States Code, §112, I acknowledge the duty to disclose information which is material to patentability as defined in Title 37, Code of Federal Regulations, §1.56 which became available between the filing date of the prior application and the national or PCT international filing date of this application:

(Application Number) (Filing Date) (Status — patented, pending, abandoned)

*NOTE: Must be completed.

I hereby appoint the following attorneys to prosecute this application and/or an international application based on this application and to transact all business in the Patent and Trademark Office connected therewith and in connection with the resulting patent based on instructions received from the entity who first sent the application papers to the attorneys identified below, unless the inventor(s) or assignee provides said attorneys with a written notice to the contrary:

RAYMOND C. STEWART (Reg. No. 21,066)
 JOSEPH A. KOLASCH (Reg. No. 22,463)
 JAMES M. SLATTERY (Reg. No. 28,380)
~~DONALD C. KOLASCH (Reg. No. 28,380)~~
 CHARLES GORENSTEIN (Reg. No. 29,271)
 LEONARD R. SVENSSON (Reg. No. 30,330)
 MARC S. WEINER (Reg. No. 32,181)
 JOE MCKINNEY MUNCY (Reg. No. 32,334)
 C. JOSEPH FARACI (Reg. No. 32,350)

TERRELL C. BIRCH (Reg. No. 19,382)
 ANTHONY L. BIRCH (Reg. No. 26,122)
 BERNARD L. SWEENEY (Reg. No. 24,448)
 MICHAEL K. MUTTER (Reg. No. 29,680)
 GERALD M. MURPHY, JR. (Reg. No. 28,977)
 TERRY L. CLARK (Reg. No. 32,644)
 ANDREW D. MEIKLE (Reg. No. 32,868)
 ANDREW F. REISH (Reg. No. 33,443)

PLEASE NOTE:
 YOU MUST
 COMPLETE THE
 FOLLOWING:

Send Correspondence to: **BIRCH, STEWART, KOLASCH AND BIRCH, LLP**

P.O. Box 747
 Falls Church, Virginia 22040-0747
 Telephone: (703) 205-8000
 Facsimile: (703) 205-8050

I hereby declare that all statements made herein of my own knowledge are true and that all statements made on information and belief are believed to be true; and further that these statements were made with the knowledge that willful false statements and the like so made are punishable by fine or imprisonment, or both, under Section 1001 of Title 18 of the United States Code and that such willful false statements may jeopardize the validity of the application or any patent issued thereon.

Full Name of First or Sole Inventor:
 Insert Name of Inventor
 Insert Date This Document Is Signed

GIVEN NAME	FAMILY NAME	INVENTOR'S SIGNATURE	DATE*
Yoshinori	SHIMIZU	<i>Yoshinori Shimizu</i>	07/22/1997
Residence (City, State & Country)		CITIZENSHIP	
Naka-gun, Tokushima, Japan		Japan	

Insert Post Office Address

POST OFFICE ADDRESS (Complete Street Address including City, State & Country)
 c/o Nichia Kagaku Kogyo Kabushiki Kaisha, 491-100, Oka, Kaminakacho, Anan-shi, TOKUSHIMA 774 JAPAN

Full Name of Second Inventor, if any:
 see above

GIVEN NAME	FAMILY NAME	INVENTOR'S SIGNATURE	DATE*
Kensho	SAKANO	<i>Kensho Sakano</i>	07/22/1997
Residence (City, State & Country)		CITIZENSHIP	
Anan-shi, Tokushima, Japan		Japan	

POST OFFICE ADDRESS (Complete Street Address including City, State & Country)
 c/o Nichia Kagaku Kogyo Kabushiki Kaisha, 491-100, Oka, Kaminakacho, Anan-shi, TOKUSHIMA 774 JAPAN

Full Name of Third Inventor, if any:
 see above

GIVEN NAME	FAMILY NAME	INVENTOR'S SIGNATURE	DATE*
Yasunobu	NOGUCHI	<i>Yasunobu Noguchi</i>	07/22/1997
Residence (City, State & Country)		CITIZENSHIP	
Naka-gun, Tokushima, Japan		Japan	

POST OFFICE ADDRESS (Complete Street Address including City, State & Country)
 c/o Nichia Kagaku Kogyo Kabushiki Kaisha, 491-100, Oka, Kaminakacho, Anan-shi, TOKUSHIMA 774 JAPAN

Full Name of Fourth Inventor, if any:
 see above

GIVEN NAME	FAMILY NAME	INVENTOR'S SIGNATURE	DATE*
Toshio	MORIGUCHI	<i>Toshio Moriguchi</i>	07/22/1997
Residence (City, State & Country)		CITIZENSHIP	
Anan-shi, Tokushima, Japan		Japan	

POST OFFICE ADDRESS (Complete Street Address including City, State & Country)
 c/o Nichia Kagaku Kogyo Kabushiki Kaisha, 491-100, Oka, Kaminakacho, Anan-shi, TOKUSHIMA 774 JAPAN

Full Name of Fifth Inventor, if any:
 see above

GIVEN NAME	FAMILY NAME	INVENTOR'S SIGNATURE	DATE*
Residence (City, State & Country)		CITIZENSHIP	

POST OFFICE ADDRESS (Complete Street Address including City, State & Country)

*Note: Must be completed — date this document is signed.

Electronic Patent Application Fee Transmittal

Application Number:				
Filing Date:				
Title of Invention:	LIGHT EMITTING DEVICE AND DISPLAY			
First Named Inventor/Applicant Name:	Yoshinori SHIMIZU			
Filer:	Andrew Duff Meikle/Lisa Strandberg			
Attorney Docket Number:	0020-5147PUS5			
Filed as Large Entity				
Utility under 35 USC 111(a) Filing Fees				
Description	Fee Code	Quantity	Amount	Sub-Total in USD(\$)
Basic Filing:				
Utility application filing	1011	1	330	330
Utility Search Fee	1111	1	540	540
Utility Examination Fee	1311	1	220	220
Pages:				
Claims:				
Miscellaneous-Filing:				
Petition:				
Patent-Appeals-and-Interference:				

Description	Fee Code	Quantity	Amount	Sub-Total in USD(\$)
Post-Allowance-and-Post-Issuance:				
Extension-of-Time:				
Miscellaneous:				
Total in USD (\$)				1090

Electronic Acknowledgement Receipt

EFS ID:	5963574
Application Number:	12548618
International Application Number:	
Confirmation Number:	7447
Title of Invention:	LIGHT EMITTING DEVICE AND DISPLAY
First Named Inventor/Applicant Name:	Yoshinori SHIMIZU
Customer Number:	02292
Filer:	Andrew Duff Meikle/Lisa Strandberg
Filer Authorized By:	Andrew Duff Meikle
Attorney Docket Number:	0020-5147PUS5
Receipt Date:	27-AUG-2009
Filing Date:	
Time Stamp:	12:57:44
Application Type:	Utility under 35 USC 111(a)

Payment information:

Submitted with Payment	yes
Payment Type	Deposit Account
Payment was successfully received in RAM	\$1090
RAM confirmation Number	10524
Deposit Account	022448
Authorized User	

The Director of the USPTO is hereby authorized to charge indicated fees and credit any overpayment as follows:

Charge any Additional Fees required under 37 C.F.R. Section 1.16 (National application filing, search, and examination fees)

Charge any Additional Fees required under 37 C.F.R. Section 1.17 (Patent application and reexamination processing fees)

File Listing:

Document Number	Document Description	File Name	File Size(Bytes)/ Message Digest	Multi Part /.zip	Pages (if appl.)
1		TransmittalIDS.pdf	776221 <small>d513cd57b871fb189d50672b386dc5b2f03790a4</small>	yes	13
Multipart Description/PDF files in .zip description					
	Document Description		Start		End
	Miscellaneous Incoming Letter		1		1
	Transmittal of New Application		2		2
	Transmittal Letter		3		7
	Information Disclosure Statement (IDS) Filed (SB/08)		8		12
	Miscellaneous Incoming Letter		13		13
Warnings:					
Information:					
2		SpecificationDeclarationDrawings.pdf	3654507 <small>c1e52ce41ddd940e7943d33187fb4de620531253</small>	yes	81
Multipart Description/PDF files in .zip description					
	Document Description		Start		End
	Specification		1		56
	Claims		57		59
	Abstract		60		60
	Drawings-only black and white line drawings		61		79
	Oath or Declaration filed		80		81
Warnings:					
Information:					
3	Fee Worksheet (PTO-875)	fee-info.pdf	32883 <small>46d8dc980488c6332454b21b6d7e8d917d31ddf1</small>	no	2
Warnings:					
Information:					

This Acknowledgement Receipt evidences receipt on the noted date by the USPTO of the indicated documents, characterized by the applicant, and including page counts, where applicable. It serves as evidence of receipt similar to a Post Card, as described in MPEP 503.

New Applications Under 35 U.S.C. 111

If a new application is being filed and the application includes the necessary components for a filing date (see 37 CFR 1.53(b)-(d) and MPEP 506), a Filing Receipt (37 CFR 1.54) will be issued in due course and the date shown on this Acknowledgement Receipt will establish the filing date of the application.

National Stage of an International Application under 35 U.S.C. 371

If a timely submission to enter the national stage of an international application is compliant with the conditions of 35 U.S.C. 371 and other applicable requirements a Form PCT/DO/EO/903 indicating acceptance of the application as a national stage submission under 35 U.S.C. 371 will be issued in addition to the Filing Receipt, in due course.

New International Application Filed with the USPTO as a Receiving Office

If a new international application is being filed and the international application includes the necessary components for an international filing date (see PCT Article 11 and MPEP 1810), a Notification of the International Application Number and of the International Filing Date (Form PCT/RO/105) will be issued in due course, subject to prescriptions concerning national security, and the date shown on this Acknowledgement Receipt will establish the international filing date of the application.

Electronic Acknowledgement Receipt

EFS ID:	5963574
Application Number:	12548618
International Application Number:	
Confirmation Number:	7447
Title of Invention:	LIGHT EMITTING DEVICE AND DISPLAY
First Named Inventor/Applicant Name:	Yoshinori SHIMIZU
Customer Number:	02292
Filer:	Andrew Duff Meikle/Lisa Strandberg
Filer Authorized By:	Andrew Duff Meikle
Attorney Docket Number:	0020-5147PUS5
Receipt Date:	27-AUG-2009
Filing Date:	
Time Stamp:	12:57:44
Application Type:	Utility under 35 USC 111(a)

Payment information:

Submitted with Payment	yes
Payment Type	Deposit Account
Payment was successfully received in RAM	\$1090
RAM confirmation Number	10524
Deposit Account	022448
Authorized User	

The Director of the USPTO is hereby authorized to charge indicated fees and credit any overpayment as follows:

Charge any Additional Fees required under 37 C.F.R. Section 1.16 (National application filing, search, and examination fees)

Charge any Additional Fees required under 37 C.F.R. Section 1.17 (Patent application and reexamination processing fees)

File Listing:

Document Number	Document Description	File Name	File Size(Bytes)/ Message Digest	Multi Part /.zip	Pages (if appl.)
1		TransmittalIDS.pdf	776221 <small>d513cd57b871fb189d50672b386dc5b2f03790a4</small>	yes	13
Multipart Description/PDF files in .zip description					
Document Description		Start	End		
Miscellaneous Incoming Letter		1	1		
Transmittal of New Application		2	2		
Transmittal Letter		3	7		
Information Disclosure Statement (IDS) Filed (SB/08)		8	12		
Miscellaneous Incoming Letter		13	13		
Warnings:					
Information:					
2		SpecificationDeclarationDrawings.pdf	3654507 <small>c1e52ce41ddd940e7943d33187fb4de620531253</small>	yes	81
Multipart Description/PDF files in .zip description					
Document Description		Start	End		
Specification		1	56		
Claims		57	59		
Abstract		60	60		
Drawings-only black and white line drawings		61	79		
Oath or Declaration filed		80	81		
Warnings:					
Information:					
3	Fee Worksheet (PTO-875)	fee-info.pdf	32883 <small>46d8dc980488c6332454b21b6d7e8d917d31ddf1</small>	no	2
Warnings:					
Information:					

This Acknowledgement Receipt evidences receipt on the noted date by the USPTO of the indicated documents, characterized by the applicant, and including page counts, where applicable. It serves as evidence of receipt similar to a Post Card, as described in MPEP 503.

New Applications Under 35 U.S.C. 111

If a new application is being filed and the application includes the necessary components for a filing date (see 37 CFR 1.53(b)-(d) and MPEP 506), a Filing Receipt (37 CFR 1.54) will be issued in due course and the date shown on this Acknowledgement Receipt will establish the filing date of the application.

National Stage of an International Application under 35 U.S.C. 371

If a timely submission to enter the national stage of an international application is compliant with the conditions of 35 U.S.C. 371 and other applicable requirements a Form PCT/DO/EO/903 indicating acceptance of the application as a national stage submission under 35 U.S.C. 371 will be issued in addition to the Filing Receipt, in due course.

New International Application Filed with the USPTO as a Receiving Office

If a new international application is being filed and the international application includes the necessary components for an international filing date (see PCT Article 11 and MPEP 1810), a Notification of the International Application Number and of the International Filing Date (Form PCT/RO/105) will be issued in due course, subject to prescriptions concerning national security, and the date shown on this Acknowledgement Receipt will establish the international filing date of the application.

Under the Paperwork Reduction Act of 1995, no person are required to respond to a collection of information unless it displays a valid OMB control number

Effective on 12/08/2004. Fees pursuant to the Consolidated Appropriations Act, 2005 (H.R. 4818). FEE TRANSMITTAL For FY 2009		Complete if Known		
		Application Number		
<input type="checkbox"/> Applicant claims small entity status. See 37 CFR 1.27		Filing Date	AUG 27 2009	
		First Named Inventor	Yoshinori SHIMIZU	
		Examiner Name	Not Yet Assigned	
		Art Unit	N/A	
TOTAL AMOUNT OF PAYMENT	(\$)	1,090.00	Attorney Docket No.	0020-5147PUS5

METHOD OF PAYMENT (check all that apply)

Check Credit Card Money Order None Other (please identify): _____
 Deposit Account Deposit Account Number: 02-2448 Deposit Account Name: Birch, Stewart, Kolasch & Birch, LLP

For the above-identified deposit account, the Director is hereby authorized to: (check all that apply)

Charge fee(s) indicated below Charge fee(s) indicated below, **except for the filing fee**
 Charge any additional fee(s) or underpayments of fee(s) under 37 CFR 1.16 and 1.17 Credit any overpayments

FEE CALCULATION**1. BASIC FILING, SEARCH, AND EXAMINATION FEES**

Application Type	FILING FEES		SEARCH FEES		EXAMINATION FEES		Fees Paid (\$)
	Fee (\$)	Small Entity Fee (\$)	Fee (\$)	Small Entity Fee (\$)	Fee (\$)	Small Entity Fee (\$)	
Utility	330	165	540	270	220	110	1,090.00
Design	220	110	100	50	140	70	
Plant	220	110	330	165	170	85	
Reissue	330	165	540	270	650	325	
Provisional	220	110	0	0	0	0	

2. EXCESS CLAIM FEES

Fee Description	Small Entity Fee (\$)	Small Entity Fee (\$)
Each claim over 20 (including Reissues)	52	26
Each independent claim over 3 (including Reissues)	220	110
Multiple dependent claims	390	195

Total Claims Extra Claims Fee (\$) Fee Paid (\$) Multiple Dependent Claims
14 - 20 or HP x = Fee (\$) Fee Paid (\$)

HP = highest number of total claims paid for, if greater than 20.

Indep. Claims Extra Claims Fee (\$) Fee Paid (\$)
1 - 3 or HP = x =

HP = highest number of independent claims paid for, if greater than 3.

3. APPLICATION SIZE FEE

If the specification and drawings exceed 100 sheets of paper (excluding electronically filed sequence or computer listings under 37 CFR 1.52(e)), the application size fee due is \$270 (\$135 for small entity) for each additional 50 sheets or fraction thereof. See 35 U.S.C. 41(a)(1)(G) and 37 CFR 1.16(s).

Total Sheets Extra Sheets Number of each additional 50 or fraction thereof Fee (\$) Fee Paid (\$)
79 - 100 = /50 = (round up to a whole number) x =

4. OTHER FEE(S)

Non-English Specification, \$130 fee (no small entity discount)

Other (e.g., late filing surcharge): _____

SUBMITTED BY

Signature		Registration No. (Attorney/Agent)	32,868	Telephone	(703) 205-8000
Name (Print/Type)	Andrew D. Meikle	Date	AUG 27 2009		

Filing Date: 08/27/09

Approved for use through 7/31/2006. OMB 0651-0032

U.S. Patent and Trademark Office; U.S. DEPARTMENT OF COMMERCE

Under the Paperwork Reduction Act of 1995, no persons are required to respond to a collection of information unless it displays a valid OMB control number.

PATENT APPLICATION FEE DETERMINATION RECORD Substitute for Form PTO-875	Application or Docket Number 12/548,618
---	---

APPLICATION AS FILED – PART I			SMALL ENTITY		OTHER THAN SMALL ENTITY	
(Column 1)		(Column 2)	RATE (\$)	FEE (\$)		
FOR	NUMBER FILED	NUMBER EXTRA				
BASIC FEE (37 CFR 1.16(a), (b), or (c))	N/A	N/A	N/A		N/A	330
SEARCH FEE (37 CFR 1.16(k), (l), or (m))	N/A	N/A	N/A		N/A	540
EXAMINATION FEE (37 CFR 1.16(o), (p), or (q))	N/A	N/A	N/A		N/A	220
TOTAL CLAIMS (37 CFR 1.16(j))	14	minus 20 =	x\$26		x\$52	
INDEPENDENT CLAIMS (37 CFR 1.16(h))	1	minus 3 = *	x\$110		x\$220	
APPLICATION SIZE FEE (37 CFR 1.16(s))	If the specification and drawings exceed 100 sheets of paper, the application size fee due is \$260 (\$130 for small entity) for each additional 50 sheets or fraction thereof. See 35 U.S.C. 41(a)(1)(G) and 37 CFR					
MULTIPLE DEPENDENT CLAIM PRESENT (37 CFR 1.16(j))			195		390	
			TOTAL		TOTAL	1090

* If the difference in column 1 is less than zero, enter "0" in column 2.

APPLICATION AS AMENDED – PART II					SMALL ENTITY		OTHER THAN SMALL ENTITY		
(Column 1)		(Column 2)	(Column 3)		RATE (\$)	ADDITIONAL FEE (\$)			
AMENDMENT A		CLAIMS REMAINING AFTER AMENDMENT		HIGHEST NUMBER PREVIOUSLY PAID FOR			RATE (\$)	ADDITIONAL FEE (\$)	
	Total (37 CFR 1.16(i))	*	Minus	**	=	X	=	X	
	Independent (37 CFR 1.16(h))	*	Minus	***	=	X	=	X	
	Application Size Fee (37 CFR 1.16(s))								
	FIRST PRESENTATION OF MULTIPLE DEPENDENT CLAIM (37 CFR 1.16(j))					N/A		N/A	
					TOTAL ADD'T FEE		TOTAL ADD'T FEE		

APPLICATION AS AMENDED – PART II					SMALL ENTITY		OTHER THAN SMALL ENTITY		
(Column 1)		(Column 2)	(Column 3)		RATE (\$)	ADDITIONAL FEE (\$)			
AMENDMENT B		CLAIMS REMAINING AFTER AMENDMENT		HIGHEST NUMBER PREVIOUSLY PAID FOR			RATE (\$)	ADDITIONAL FEE (\$)	
	Total (37 CFR 1.16(i))	*	Minus	**	=	X	=	X	
	Independent (37 CFR 1.16(h))	*	Minus	***	=	X	=	X	
	Application Size Fee (37 CFR 1.16(s))								
	FIRST PRESENTATION OF MULTIPLE DEPENDENT CLAIM (37 CFR 1.16(j))					N/A		N/A	
					TOTAL ADD'T FEE		TOTAL ADD'T FEE		

* If the entry in column 1 is less than the entry in column 2, write "0" in column 3.
 ** If the "Highest Number Previously Paid For" IN THIS SPACE is less than 20, enter "20".
 *** If the "Highest Number Previously Paid For" IN THIS SPACE is less than 3, enter "3".
 The "Highest Number Previously Paid For" (Total or Independent) is the highest number found in the appropriate box in column 1.

This collection of information is required by 37 CFR 1.16. The information is required to obtain or retain a benefit by the public which is to file (and by the USPTO to process) an application. Confidentiality is governed by 35 U.S.C. 122 and 37 CFR 1.14. This collection is estimated to take 12 minutes to complete, including gathering, preparing, and submitting the completed application form to the USPTO. Time will vary depending upon the individual case. Any comments on the amount of time you require to complete this form and/or suggestions for reducing this burden, should be sent to the Chief Information Officer, U.S. Patent and Trademark Office, U.S. Department of Commerce, P.O. Box 1450, Alexandria, VA 22313-1450. DO NOT SEND FEES OR COMPLETED FORMS TO THIS ADDRESS. SEND TO: Commissioner for Patents, P.O. Box 1450, Alexandria, VA 22313-1450.

If you need assistance in completing the form, call 1-800-PTO-9199 and select option 2.