



UNITED STATES PATENT AND TRADEMARK OFFICE

UNITED STATES DEPARTMENT OF COMMERCE  
United States Patent and Trademark Office  
Address: COMMISSIONER FOR PATENTS  
P.O. Box 1450  
Alexandria, Virginia 22313-1450  
www.uspto.gov

APPLICATION NO.	FILING DATE	FIRST NAMED INVENTOR	ATTORNEY DOCKET NO.	CONFIRMATION NO.
90/010,940	05/06/2010	6600175	1300-000044/US/RXA	4549

23448            7590            05/24/2012

Hultquist IP  
P.O. Box 14329  
RESEARCH TRIANGLE PARK, NC 27709

EXAMINER

ART UNIT            PAPER NUMBER

DATE MAILED: 05/24/2012

Please find below and/or attached an Office communication concerning this application or proceeding.



**DO NOT USE IN PALM PRINTER**

(THIRD PARTY REQUESTER'S CORRESPONDENCE ADDRESS)

HARNES, DICKEY & PIERCE, P.L.C.

P.O. BOX 828

BLOOMFIELD HILLS, MI 48303

**EX PARTE REEXAMINATION COMMUNICATION TRANSMITTAL FORM**

REEXAMINATION CONTROL NO. 90/010,940.

PATENT NO. 6600175.

ART UNIT 3992.

Enclosed is a copy of the latest communication from the United States Patent and Trademark Office in the above identified *ex parte* reexamination proceeding (37 CFR 1.550(f)).

Where this copy is supplied after the reply by requester, 37 CFR 1.535, or the time for filing a reply has passed, no submission on behalf of the *ex parte* reexamination requester will be acknowledged or considered (37 CFR 1.550(g)).

<b>Office Action in Ex Parte Reexamination</b>	Control No. 90/010,940	Patent Under Reexamination 6600175
	Examiner ERIK KIELIN	Art Unit 3992

-- The MAILING DATE of this communication appears on the cover sheet with the correspondence address --

- a  Responsive to the communication(s) filed on 26 March 2012.      b  This action is made FINAL.  
c  A statement under 37 CFR 1.530 has not been received from the patent owner.

A shortened statutory period for response to this action is set to expire 2 month(s) from the mailing date of this letter. Failure to respond within the period for response will result in termination of the proceeding and issuance of an *ex parte* reexamination certificate in accordance with this action. 37 CFR 1.550(d). **EXTENSIONS OF TIME ARE GOVERNED BY 37 CFR 1.550(c)**. If the period for response specified above is less than thirty (30) days, a response within the statutory minimum of thirty (30) days will be considered timely.

Part I THE FOLLOWING ATTACHMENT(S) ARE PART OF THIS ACTION:

1.  Notice of References Cited by Examiner, PTO-892.      3.  Interview Summary, PTO-474.  
2.  Information Disclosure Statement, PTO/SB/08.      4.  \_\_\_\_\_.

Part II SUMMARY OF ACTION

- 1a.  Claims 1-5, 11-13, 21-24 and 26-188 are subject to reexamination.  
1b.  Claims 6-10, 14-20 and 25 are not subject to reexamination.  
2.  Claims \_\_\_\_\_ have been canceled in the present reexamination proceeding.  
3.  Claims \_\_\_\_\_ are patentable and/or confirmed.  
4.  Claims 1-5, 11-13, 21-24 and 26-188 are rejected.  
5.  Claims \_\_\_\_\_ are objected to.  
6.  The drawings, filed on \_\_\_\_\_ are acceptable.  
7.  The proposed drawing correction, filed on \_\_\_\_\_ has been (7a)  approved (7b)  disapproved.  
8.  Acknowledgment is made of the priority claim under 35 U.S.C. § 119(a)-(d) or (f).  
a)  All b)  Some\* c)  None of the certified copies have  
1  been received.  
2  not been received.  
3  been filed in Application No. \_\_\_\_\_ .  
4  been filed in reexamination Control No. \_\_\_\_\_.  
5  been received by the International Bureau in PCT application No. \_\_\_\_\_.  
\* See the attached detailed Office action for a list of the certified copies not received.  
9.  Since the proceeding appears to be in condition for issuance of an *ex parte* reexamination certificate except for formal matters, prosecution as to the merits is closed in accordance with the practice under *Ex parte* Quayle, 1935 C.D. 11, 453 O.G. 213.  
10.  Other: \_\_\_\_\_

cc: Requester (if third party requester)

Art Unit: 3992

**DETAILED ACTION**

This action is on the claims for which a substantial new question of patentability has been requested and determined to exist; that is claims 1-5, 11-13, 21-24, and 26 of US 6,600,175 to Bruce Baretz and Michael Tischler (the '175 patent, hereafter) and proposed new claims 27-61 submitted in the Amendment dated 5/3/2011 and Proposed new claims 62-188 submitted in the Amendment dated 3/26/2012.

Since requester did not request reexamination of claims 6-10, 14-20, and 25, and did not assert the existence of a substantial new question of patentability (SNQ) for said claims, they will not be reexamined. See MPEP 2243.

This action responds to Patentee's submissions of 2/13/2012 (IDS), 2/29/2012 (IDS), 3/26/2012 (Amendment and Remarks), and 4/4/2012 (IDS).

**Table of Contents**

- I. Information Disclosure Statement..... 8
- II. Claim Status ..... 8
- III. The References ..... 8
- IV. Claim Rejections - 35 USC § 112 ..... 10
  - A. Proposed new claims 62-99, 149-171, 178, 187, and 188 are rejected under 35 U.S.C. 112, first paragraph, as failing to comply with the enablement requirement. .... 10
- V. Claim Rejections - 35 USC § 102 and 35 USC § 103 ..... 14
  - A. Statute ..... 14
    - 1. 35 USC 102..... 14
    - 2. 35 USC 103..... 15
  - B. Comment regarding new claims 62-99, 149-171, 178, 187, and 188 ..... 15
  - C. Stevenson as a base reference ..... 15
    - 1. Claims 1, 5, 12, 13, 21, 22, 26, 27, 31-33, 41, 45-47, 55, 59-61, 172, 176, and 178 are rejected under 35 U.S.C. 102(b) as being anticipated over Stevenson, as evidenced by the CRC Handbook. .... 15
    - 2. Claims 1, 5, 12, 13, 21, 22, 26, 27, 31-33, 41, 45-47, 55, 59-61, 172, 176, and 178 are rejected under 35 U.S.C. 103(a) as being unpatentable over Stevenson in view of any of Pinnow, Menda, and Admitted Prior Art (APA). .... 25
    - 3. Claims 1, 3-5, 12, 13, 21, 22, 26, 62, 63, 69-72, 74, 76-79, 100, 101, 106-110, 112, 114-116, 118, 124-126, 128, 130-132, 134, 137, 140-142, 145-147, 172, 176, and 178 are rejected under 35 U.S.C. 103(a) as being unpatentable over Stevenson in view of Pinnow and Nakamura. .... 31



Art Unit: 3992

4. Claims 187 and 188 are rejected under 35 U.S.C. 103(a) as being unpatentable over Stevenson in view of Pinnow and Tadatsu. .... 42

5. Claims 63-65, 68, 70-73, 101-103, 106, 108-111, 119-121, 124, 126, 127, 135-137, 140, 142, 143, 187 and 188 are rejected under 35 U.S.C. 103(a) as being unpatentable over Stevenson in view of Pinnow and Nakamura as applied to claims 62, 100, 118, and 134, above, and further in view of Tadatsu. .... 45

6. Claims 63, 66-72, 74, 101, 104-110, 112, 121-126, 128, 137-142, 162-166 and 168-171 are rejected under 35 U.S.C. 103(a) as being unpatentable over Stevenson in view of Pinnow and Nakamura as applied to claims 62, 100, 118, and 134, above, and further in view of Tabuchi. .... 49

7. Claims 5, 11-13, 21, 22, 26, 172, and 176 is rejected under 35 U.S.C. 103(a) as being unpatentable over Stevenson in view of Pinnow and Edmond..... 57

8. Claims 2 and 23 are rejected under 35 U.S.C. 103(a) as being unpatentable over any of (1) Stevenson in view of **Imamura**, (2) Stevenson in view of any of Pinnow, Menda, and APA, and further in view of **Imamura**, (3) Stevenson in view of Pinnow, Nakamura, and **Imamura**, and (4) Stevenson in view of Pinnow, Edmond and **Imamura**. .... 59

9. Claims 1, 5, 12, 13, 21, 22, 26-28, 30-33, 41, 42, 44-47, 55, 56, 58-61, 172, 173, 176-178, 187, and 188 are rejected under 35 U.S.C. 103(a) as being unpatentable over Stevenson in view of **Tadatsu** or, in the alternative, over Stevenson in view of APA and **Tadatsu**. .... 61

10. Claims 28-30, 42-44, 56-58, 173, and 177 are rejected under 35 U.S.C. 103(a) as being unpatentable over Stevenson in view of **Tabuchi** or, in the alternative, over Stevenson in view of APA and **Tabuchi**. .... 64

11. Claims 3, 34, 38-40 are rejected under 35 U.S.C. 103(a) as being unpatentable over Stevenson in view of APA and Nakamura. .... 67

12. Claims 62, 75, 100, and 113 are rejected under 35 U.S.C. 103(a) as being unpatentable over Stevenson in view of APA, Wanmaker, and Nakamura..... 72

13. Claims 3, 34, 35, 37-40, and 179 are rejected under 35 U.S.C. 103(a) as being unpatentable over Stevenson in view of APA and Nakamura and further in view of Tadatsu. .... 76

14. Claims 35-37 are rejected under 35 U.S.C. 103(a) as being unpatentable over Stevenson in view of APA and Nakamura and further in view of Tabuchi. .... 78

15. Claims 79, 80, 116-118, 129, 132-134, 144, 147, 148, 162, and 167 are rejected under 35 U.S.C. 103(a) as being unpatentable over Stevenson in view of APA, Wanmaker, and Nakamura and further in view of Tabuchi and Martic. .... 78

D. Tabuchi as a base reference ..... 82

1. Claims 1, 5, 22, 26, 172, 173, 176, and 177 are rejected under 35 U.S.C. 102(b) as being anticipated by Tabuchi, as evidenced by the CRC Handbook. .... 82

2. Claims 1, 5, 22, 26, 27-32, 41-46, 55-60, 172, 173, 176, and 177 are rejected under 35 U.S.C. 103(a) as being unpatentable over Tabuchi in view of Admitted Prior Art (APA). .... 87

Art Unit: 3992

3. Claims 1, 5, 22, 26, 172, 173, 176, 177, and 187 are rejected under 35 U.S.C. 103(a) as being unpatentable over Tabuchi in view of Pinnow. .... 90

4. Claims 2 and 23 are rejected under 35 U.S.C. 103(a) as being unpatentable over any of (1) Tabuchi in view of Stevenson and Imamura, (2) Tabuchi in view of APA, Stevenson, and Imamura, and (3) Tabuchi in view of Pinnow, Stevenson, and Imamura. .... 92

5. Claims 3, 4, and 34-40 are rejected under 35 U.S.C. 103(a) as being unpatentable over Tabuchi in view of APA and Nakamura..... 94

6. Claims 62, 63, 66-69, 74-80, 100, 101, 104-107, 110, 112-117, 162, and 164-171 are rejected under 35 U.S.C. 103(a) as being unpatentable over Tabuchi in view of APA, Wanmaker, and Nakamura..... 98

7. Claims 118, 121-126, 128-134, 137-142, and 144-148 are rejected under 35 U.S.C. 103(a) as being unpatentable over Tabuchi in view of APA, Wanmaker, Nakamura, and Martic..... 105

8. Claims 34, 35, 37-40 and 179 are rejected under 35 U.S.C. 103(a) as being unpatentable over Tabuchi in view of APA and Nakamura as applied to claims 3, 4, 34, and 38-40, above, and further in view of Tadatsu. .... 110

9. Claims 3-5, 12, 13, 21, 22, 26, 62, 63, 66-72, 74, 76-79, 100, 101, 104-110, 112, 114-116, 118, 121-126, 128, 130-132, 134, 137-142, 145-147, 162-166, 168-172, 178, 187, and 188 are rejected under 35 U.S.C. 103(a) as being unpatentable over Tabuchi in view of Pinnow and Nakamura. .... 111

10. Claims 64, 65, 73, 102, 103, 111, 119, 120, 127, 135, 136, and 143 are rejected under 35 U.S.C. 103(a) as being unpatentable over Tabuchi in view of Pinnow and Nakamura as applied to claims 62, 72, 100, 110, 118, 126, 134, and 142, above, and further in view of Tadatsu. .... 126

11. Claims 5, 11-13, 22, 26, 172, 173, 187, and 188 are rejected under 35 U.S.C. 103(a) as being unpatentable over Tabuchi in view of Pinnow and Edmond..... 129

E. Menda as a base reference ..... 131

1. Claims 1, 3, 5, 22, and 26 are rejected under 35 U.S.C. 102(b) as being anticipated by Menda, as evidenced by any of Penguin, Fundamentals of Photonics, Morkoç, Abe, Tadatomo and LEDLASER..... 131

2. Claims 2, 23, 24, 180, 181, and 186 are rejected under 35 U.S.C. 103(a) as being unpatentable over Menda, as evidenced by any of Penguin, Fundamentals of Photonics, Morkoç, Abe, and Tadatomo, and in view of Imamura. .... 144

3. Claims 1, 3, and 5 are rejected under 35 U.S.C. 103(a) as being unpatentable over Menda in view of any of Fundamentals of Photonics, Morkoç, Abe, and Tadatomo.... 147

4. Claims 21, 22, and 26 are rejected under 35 U.S.C. 103(a) as being unpatentable over Menda in view of Tadatomo. .... 153

5. Claims 2, 23, 24, 180, 181, and 186 are rejected under 35 U.S.C. 103(a) as being unpatentable over Menda in view of any of Fundamentals of Photonics, Morkoç, Abe, and Tadatomo and further in view of Imamura. .... 154

6. Claims 4 and 11-13 are rejected under 35 U.S.C. 103(a) as being unpatentable over Menda in view of Morkoç. .... 157

Art Unit: 3992

7. Claims 48 and 52-54 are rejected under 35 U.S.C. 103(a) as being unpatentable over Menda in view of either of Morkoç and Tadatomo, as applied to claim 24 above, and further in view of Uehara or, in the alternative, over Menda in view of Imamura and either of Morkoç and Tadatomo, as applied to claim 24, above, and further in view of Uehara. .... 158

8. Claims 49-51 are rejected under 35 U.S.C. 103(a) as being unpatentable over Menda in view of Uehara and either of Morkoç and Tadatomo as applied to claim 48, above, and further in view of Abe or, in the alternative, over Menda in view of Imamura, Uehara, and either of Morkoç and Tadatomo as applied to claim 48, above, and further in view of Abe. .... 162

F. Abe as a base reference ..... 165

1. Claims 3, 4, and 34-37 are rejected under 35 U.S.C. 102(e) as being anticipated by Abe. .... 165

2. Claims 1, 2, 5, 23, 27-30, 41-44, 172, and 173 are rejected under 35 U.S.C. 102(e) as being anticipated by Abe, as evidenced by LEDLASER. .... 167

3. Claims 22, 26, 55-58, 176, and 177 are rejected under 35 U.S.C. 102(e) as being anticipated by Abe, as evidenced by LEDLASER and M-H Encyclopedia. .... 170

4. Claims 11-13, 31-33, 38-40, 45-47, 59-63, 68, 69, 72, 74-80, 100, 101, 106, 107, 110, 112, 113-117, 162, 164, 166, 167-171, and 178 are rejected under 35 U.S.C. 103(a) as being unpatentable over Abe, as evidenced by LEDLASER, in view of Morkoç. .... 172

G. Lenko as a base reference (The liquid crystal display claims)..... 178

1. Claims 24, 48, 52-54, 81, 82, 94-98, 174, and 182-185 are rejected under 35 U.S.C. 103(a) as being unpatentable over Lenko in view of either of Menda and Pinnow, and further in view of Stevenson, as evidenced by the CRC Handbook..... 179

2. Claims 24, 48, 52-54, 81, 82, 94-98, 174, and 182-185 are rejected under 35 U.S.C. 103(a) as being unpatentable over Lenko in view of either of Menda and Pinnow, and further in view of Stevenson in view of any of Pinnow, Menda, and Admitted Prior Art (APA). .... 184

3. Claims 81, 82, 95-98, and 182-185 are rejected under 35 U.S.C. 103(a) as being unpatentable over Lenko in view of either of Menda and Pinnow, and further in view of Stevenson, Pinnow, and Nakamura. .... 185

4. Claims 83, 84, 87, 89-92, 149-152, 155, 157, 158, 160, and 161 are rejected under 35 U.S.C. 103(a) as being unpatentable over Lenko in view of either of Menda and Pinnow, and further in view of Stevenson, Pinnow, Nakamura, and **Tadatsu**..... 185

5. Claims 85-88, 91, 93, 149, 152-157, and 175 are rejected under 35 U.S.C. 103(a) as being unpatentable over Lenko in view of either of Menda and Pinnow, and further in view of Stevenson, Pinnow, Nakamura, and **Tabuchi**. .... 187

6. Claims 49 and 51 are rejected under 35 U.S.C. 103(a) as being unpatentable over Lenko in view of either of Menda and Pinnow, and further in view of either (1) Stevenson and **Tadatsu**, or (2) Stevenson, APA, and **Tadatsu** ..... 189

Art Unit: 3992

7. Claims 49-51 and 175 are rejected under 35 U.S.C. 103(a) as being unpatentable over Lenko in view of either of Menda and Pinnow, and further in view of either (1) Stevenson and **Tabuchi**, or (2) Stevenson, APA, and **Tabuchi**..... 190

8. Claims 81, 82, 94-98, and 182-185 are rejected under 35 U.S.C. 103(a) as being unpatentable over Lenko in view of either of Menda and Pinnow, and further in view of Stevenson, APA, Wanmaker and Nakamura ..... 191

9. Claim 99 is rejected under 35 U.S.C. 103(a) as being unpatentable over Lenko in view of either of Menda and Pinnow, and further in view of Stevenson, APA, Wanmaker, Nakamura, and **Tabuchi** ..... 192

10. Claims 149 and 159 are rejected under 35 U.S.C. 103(a) as being unpatentable over Lenko in view of either of Menda and Pinnow, and further in view of Stevenson, APA, Wanmaker, Nakamura, **Tabuchi and Martic**..... 192

11. Claims 24 and 48-53 are rejected under 35 U.S.C. 103(a) as being unpatentable over Lenko in view of either of Menda and Pinnow, and further in view of Tabuchi and APA..... 193

12. Claims 52-54 are rejected under 35 U.S.C. 103(a) as being unpatentable over Lenko in view of either of Menda and Pinnow, and further in view of Tabuchi, APA, and Nakamura..... 195

13. Claims 81, 82, 85-88, and 93-99 are rejected under 35 U.S.C. 103(a) as being unpatentable over Lenko in view of either of Menda and Pinnow, and further in view of Tabuchi, APA, Wanmaker, and Nakamura. .... 196

14. Claims 89-91, 149, 152-157, and 159-161 are rejected under 35 U.S.C. 103(a) as being unpatentable over Lenko in view of either of Menda and Pinnow, and further in view of Tabuchi, APA, Wanmaker, Nakamura, and Martic..... 198

15. Claim 24 is rejected under 35 U.S.C. 103(a) as being unpatentable over Lenko in view of either of Menda and Pinnow, and further in view of Tabuchi and APA..... 200

16. Claims 81, 82, 85-91, 93, and 95-98 are rejected under 35 U.S.C. 103(a) as being unpatentable over Lenko in view of either of Menda and Pinnow, and further in view of Tabuchi, Pinnow, and Nakamura..... 202

17. Claims 83, 84, 89-92, 149-152, 155, 157, 158, 160, and 161 are rejected under 35 U.S.C. 103(a) as being unpatentable over Lenko in view of either of Menda and Pinnow, and further in view of Tabuchi, Pinnow, Nakamura, and Tadatsu..... 203

VI. Response to Arguments ..... 205

A. Patentee’s general arguments directed to Menda ..... 205

1. Patentee and Stringfellow merely speculate that Menda is related to large area displays..... 205

2. Patentee and Stringfellow unnecessarily limit the disclosure in Menda ..... 207

3. Menda’s alternative sources of radiation, e.g. X-ray,  $\beta$ -ray,  $\gamma$ -rays do not negate the explicit disclosure of “solid ultraviolet light emitting element having a structure of a pn junction, MOS junction or the like” ..... 208

4. The ‘175 patent uses commercially available GaN-based LEDs that Patentee and Stringfellow argues would not work..... 209



Art Unit: 3992

- 5. Examiner never even hinted that Menda failed to implicitly disclose single-die semiconductor LEDs ..... 211
- 6. Each of Penguin, Fundamentals of Photonics, Morkoç, Abe, Tadatomo and LEDLASER tells that it is known to those of ordinary skill that UV light-emitting pn junctions include single-die semiconductor LEDs ..... 212
- 7. Imamura uses an array of LED as a backlight for an LCD, so those of ordinary skill knew very well at the time of Menda that LEDs were a sufficient light source for back lights ..... 213
- 8. Specific rejections relying on Menda as a base reference..... 213
- B. Patentee’s general arguments directed to Stevenson ..... 214
  - 1. Patentee and Stringfellow fail to acknowledge that Stevenson’s GaN-based LED emits light in the same spectral region as the commercially available LED disclosed in the Baretz Declaration and in the ‘175 patent ..... 214
  - 2. A single white light LED was known by the time of Stevenson, Tabuchi, and Tadatsu ..... 217
  - 3. Patentee does not know what is legally meant by “teaching away” ..... 219
- C. Rejections over Abe and the Declarations filed under 37 CFR 1.131 ..... 220
  - 1. The facts in *In re Hostettler* and *In re Spiller* and *Ex parte Goddard* do not apply to the facts in these proceedings ..... 220
  - 2. The fourth Baretz, fourth Tischler, and third Elliot Declarations are ineffective in swearing behind Abe ..... 222
  - 3. Specific rejection relying on Abe as a base reference ..... 229
- D. Secondary Considerations ..... 230
  - 1. No evidence of long-felt need ..... 230
  - 2. There is no evidence of failure of others, especially since Stevenson, Tabuchi, and Abe anticipate the claimed device ..... 232
  - 3. There is no evidence of unexpected results ..... 232
  - 4. Commercial success and the third Brandes Declaration ..... 233
  - 5. The third Brandes Declaration fails to provide evidence of commercial success .... 235
- Conclusion ..... 240

THE REST OF THIS PAGE IS INTENTIONALLY LEFT BLANK.

Art Unit: 3992

### ***I. Information Disclosure Statement***

MPEP 2256 states in pertinent part,

Where patents, publications, and other such items of information are submitted by a party (Patent Owner or Requester) in compliance with the requirements of the rules, the requisite degree of consideration to be given to such information will be normally **limited by the degree to which the party filing the information citation has explained the content and relevance of the information**. The initials of the examiner placed adjacent to the citations on the form PTO /SB /08A and 08B or its equivalent, without an indication to the contrary in the record, do not signify that the information has been considered by the examiner any further than to the extent noted above.

(Emphasis added.)

In concert with MPEP 2256, unless otherwise indicated, the references submitted in the IDS filed 2/13/2012, 2/29/2012, and 4/4/2012 have been considered only to the extent that the submitting party has "explained the content and relevance".

### ***II. Claim Status***

- (1) Original claims subject to reexamination: 1-5, 11-13, 21-24, and 26
- (2) Claims not subject to reexamination: 6-10, 14-20, and 25
- (3) Canceled claims: none
- (4) Claims newly proposed: 27-188
- (5) Claims literally amended: 1, 5, 11, 12, 21, and 24
- (6) Claims effectively amended: 2 and 8-23
- (7) Claims active: 1-5, 11-13, 21-24, and 26-188

### ***III. The References***

- (1) JP 6-267301 to Kazunori Menda, published 22 September 1994 (Menda, hereafter)
- (2) US 5,535,230 to Tadashi Abe, filed 3 January 1995, issued 9 July 1996 (Abe, hereafter)
- (3) US 5,283,425 to Masaya Imamura, issued 1 February 1994 (Imamura, hereafter)

Art Unit: 3992

(4) Morkoç, et al, "Large-band-gap SIC, III-V nitride, and II-VI ZnSe-based semiconductor device technologies", *J. Appl. Phys.* 76(3), 1; March 17, 1994; Illinois University (Morkoç, hereafter)

(5) *McGraw-Hill Encyclopedia of Science & Technology*, 6<sup>th</sup> Edition, Vol. 9, pg. 582 and Vol. 10, pp. 60-63; Copyright 1987 (M-H Encyclopedia, hereafter)

(6) *McGraw-Hill Dictionary of Scientific and Technical Terms*, 3<sup>rd</sup> Edition, pp. 912, 1446; Copyright 1984 (M-H Dictionary, hereafter)

(7) *The Penguin Dictionary of Electronics*, 3<sup>rd</sup> edition, pp. 315, 437-438, 509-510, copyright 1979, 1988, and 1998 (Penguin, hereafter)

(8) "LEDs and Laser Diodes", Electus Distribution, copyright 2001, available at URL: [http://www.jaycar.com.au/images\\_uploaded/ledlaser.pdf](http://www.jaycar.com.au/images_uploaded/ledlaser.pdf) (LEDLASER, hereafter)

(9) US 4,772,885 to Uehara et al., issued 20 September 1988 (Uehara, hereafter)

(10) JP 3-24692 to Kentaro Fujii, published 14 March 1991 (Fujii, hereafter)

(11) US 5,770,887 to Tadatomo et al., filed 11 October 1994 (Tadatomo, hereafter)

(12) Saleh and Teich, *Fundamentals of Photonics*, New York: John Wiley & Sons, 1991, pp. 592-594 (Fundamentals of Photonics, hereafter)

(13) US 3,819,974 to Stevenson et al., issued 25 June 1974 (Stevenson, hereafter)

(14) US 3,691,482 to Pinnow et al., issued 12 September 1972 (Pinnow, hereafter)

(15) JP 5-152609 to Tadatsu et al., published 18 June 1993 (Tadatsu, hereafter)

(16) JP 50-79379 to Sei-ichi Tabuchi, published 24 November 1973 (Tabuchi, hereafter)

(17) CRC Handbook, 63<sup>rd</sup> Ed., (1983) p. E-201 (CRC Handbook, hereafter)

(18) US 4,918,497 to John Edmond, issued 17 April 1990 (Edmond, hereafter)

(19) US 3,793,046 to Wanmaker et al., issued 19 February 1974 (Wanmaker, hereafter)

(20) US 3,743,833 to Martic et al., issued 3 July 1973 (Martic, hereafter)

(21) Lumogen® F Violet 570 Data Sheet; available at the BASF Chemical Company website URL, [http://worldaccount.basf.com/wa/EU~en\\_GB/Catalog/Pigments/doc4/BASF/PRD/30](http://worldaccount.basf.com/wa/EU~en_GB/Catalog/Pigments/doc4/BASF/PRD/30)

Art Unit: 3992

[048274/.pdf?title=Technical%20Datasheet&asset\\_type=pds/pdf&language=EN&urn=urn:documentum:eCommerce\\_sol\\_EU:09007bb280021e27.pdf](http://048274/.pdf?title=Technical%20Datasheet&asset_type=pds/pdf&language=EN&urn=urn:documentum:eCommerce_sol_EU:09007bb280021e27.pdf)

The '175 patent was filed 26 March 1996. Each of Menda, Morkoç, M-H Encyclopedia, M-H Dictionary, Uehara, Fujii, Fundamentals of Photonics, Stevenson, Pinnow, Tadatsu, Tabuchi, and Edmond, were issued or published more than one year before the '175 patent's priority date; thus each qualifies as prior art under 35 USC 102(b).

Abe and Tadatomo were filed before the filing of the application that became the '175 patent; thus, Abe and Tadatomo qualify as prior art under 35 USC 102(e). As will be discussed below, Patentee's Declarations are ineffective to overcome Abe as prior art.

Penguin, LEDLASER, and CRC Handbook are used only for purposes of definition or evidence and therefore need not qualify as prior art.

#### **IV. Claim Rejections - 35 USC § 112**

The following is a quotation of the first paragraph of 35 U.S.C. 112:

The specification shall contain a written description of the invention, and of the manner and process of making and using it, in such full, clear, concise, and exact terms as to enable any person skilled in the art to which it pertains, or with which it is most nearly connected, to make and use the same and shall set forth the best mode contemplated by the inventor of carrying out his invention.

**A. Proposed new claims 62-99, 149-171, 178, 187, and 188 are rejected under 35 U.S.C. 112, first paragraph, as failing to comply with the enablement requirement.**

The claim(s) contains subject matter which was not described in the specification in such a way as to enable one skilled in the art to which it pertains, or with which it is most nearly connected, to make and/or use the invention.

Each of claims 62, 81, 149, 162, 178, 187, and 188 requires a primary radiation consisting of **blue** light from a GaN-based LED to be converted by phosphors to a secondary radiation composed of lower energy (longer wavelength) visible white light, wherein the secondary radiation alone --without contribution from the **blue primary** radiation-- produces white light. As claimed this reads:

(1) Claims 62, 81, 162 and 178:

*at least one single-die gallium nitride based semiconductor **blue light-emitting diode (LED)** ... said **primary radiation** being a relatively shorter wavelength **blue light radiation**; and*



Art Unit: 3992

*a down-converting luminophoric medium arranged in receiving relationship to said primary radiation, and which in exposure to **said primary radiation**, is excited to responsively emit a **secondary**, relatively **longer wavelength**, polychromatic radiation, **with separate wavelengths of said polychromatic radiation mixing** to produce a **white** light output*

(2) Claim 149:

*at least one single-die gallium nitride based semiconductor **blue light-emitting diode (LED)** coupleable with a power supply to emit a **primary blue light radiation** ...*

*a down-converting luminophoric medium arranged in receiving relationship to said primary radiation, and which in exposure to **said primary radiation** responsively emits a **secondary**, relatively **longer wavelength**, polychromatic radiation, with **separate wavelengths of said polychromatic radiation mixing** to produce a **white** light output,*

(5) Claim 187:

*a light-emitting diode operative to emit **blue** or ultraviolet **radiation**, packaged with luminophoric medium in a polymeric matrix, wherein the **luminophoric medium absorbs blue** or ultraviolet radiation from the light-emitting diode and **down converts same** to a broad spectrum of frequencies producing **polychromatic white light**,*

The first reason these claims are not enabled is that the '175 patent does not enable down-converting solely **blue** light (i.e. the primary radiation) to white light. The claim language requires the secondary or down-converted radiation **alone** to make up all of the colors that mix to produce the white light; therefore, blue light from the LED cannot be included in producing white light. However, blue light is one of the primary colors needed to produce white light. Because the LED's blue light cannot contribute to the white light output by the secondary radiation, said secondary radiation lacks the blue light wavelengths needed to produce white light. Therefore, the claims are not enabled.

The second reason the claims are not enabled comes from evidence in the '175 patent itself. As will be shown below, the '175 patent shows that the **blue** light (primary radiation) is either (1) **not** absorbed by at least one of the phosphors in the luminophoric medium needed to produce white light, or (2) is **not down-converted**, as required by the claims. In this regard, the '175 patent indicates that a commercially available blue light-emitting LED, having an emission max at 450 nm, can be used with commercially available phosphors to produce white light:

In one embodiment, LED 13 comprises a leaded, **gallium nitride based LED** which exhibits **blue light emission** with an emission maximum at approximately **450 nm** with a **FWHM of approximately 65 nm**. Such a

Art Unit: 3992

device is available commercially from Toyoda Gosei Co. Ltd. (Nishikasugai, Japan; see U.S. Pat. No. 5,369,289) or as Nichia Product No. NLPB520, NLPB300, etc. from Nichia Chemical Industries, Ltd. (Shin-Nihonkaikan Bldg. 3-7-18, Tokyo, 0108 Japan; see Japanese Patent Application 4-321,280). The down-converting material in this embodiment comprises a **blue fluorescer (Lumogen® F Violet 570--substituted naphthalenetetracarboxylic diimide)**, a green-yellow fluorescer (Lumogen® F Yellow 083--substituted perylenetetracarboxylic diimide) and a red fluorescer (Lumogen® F Red 300--substituted perylenetetracarboxylic diimide). A composition comprising such blue, green-yellow, and red fluorescent materials, all organic based, as incorporated in an insulating epoxy polymer, is available commercially from Pacific Polytech (Pacific Polytech, Incorporated, 15 Commercial Blvd., Novato, Calif. 94949-6135).

(the '175 patent, col. 9, lines 10-29; emphasis added)

As indicated in the fourth Baretz Declaration (dated 3/26/2012), given the FWHM of about 65 nm (Baretz says "70 nm"), Baretz concluded that the Nichia LED emits in a range of about 380 nm to 520 nm (fourth Baretz Declaration, dated 3/26/2012, ¶ 18), thereby including ultraviolet and violet light as well that for which Baretz used phosphors absorbing over this **entire** wavelength range (*id.*) --not just the blue. However, the claims require the **blue** light primary radiation, **alone**, be converted to all of the wavelengths of light that produce the white light. The blue range of the spectrum is 424 nm to 491.2 nm, as evidenced by the CRC Handbook (table reproduced below):

### WAVE LENGTHS OF VARIOUS RADIATIONS

	Angstroms
Cosmic rays . . . . .	0.0005
Gamma rays . . . . .	0.005-1.40
X-rays . . . . .	0.1-100
Ultra violet, below . . . . .	4000
Limit of sun's U.V. at earth's surface . . . . .	2920
Visible spectrum . . . . .	4000-7000
Violet, representative, 4100, limits . . . . .	4000-4240
Blue, representative, 4700, limits . . . . .	4240-4912
Green, representative, 5200, limits . . . . .	4912-5750
Maximum visibility . . . . .	5560
Yellow, representative, 5800, limits . . . . .	5750-5850
Orange, representative, 6000, limits . . . . .	5850-6470
Red, representative, 6500, limits . . . . .	6470-7000
Infra red, greater than . . . . .	7000
Hertzian waves, beyond . . . . .	$2.20 \times 10^6$

(CRC Handbook, 63<sup>rd</sup> Ed., p. E-201)

Art Unit: 3992

As indicated in the '175 patent, above, Luminogen® F Violet 570 is the phosphor cited in the '175 patent, above, for converting light from the Nichia GaN-LED to blue light. However, as will be shown below, Luminogen® F Violet 570 does **not** absorb blue light, as required by the claims. In this regard, the absorption and emission spectra (reproduced below) from the data sheet of Luminogen® F Violet 570 (available at the BASF Chemical Company website and attached to this action) shows that this phosphor absorbs virtually no radiation having a wavelength shorter than about 420 nm, which is **outside** the wavelength range of **blue** light (i.e. below 424 nm, which is violet light, not blue light). Thus, **given the claims as written**, the claims are not enabled for **down-converting blue radiation** using the phosphor since said blue light is **not absorbed** by the very phosphor (Luminogen® F Violet 570) that the '175 patent indicates is responsible for producing the blue light.

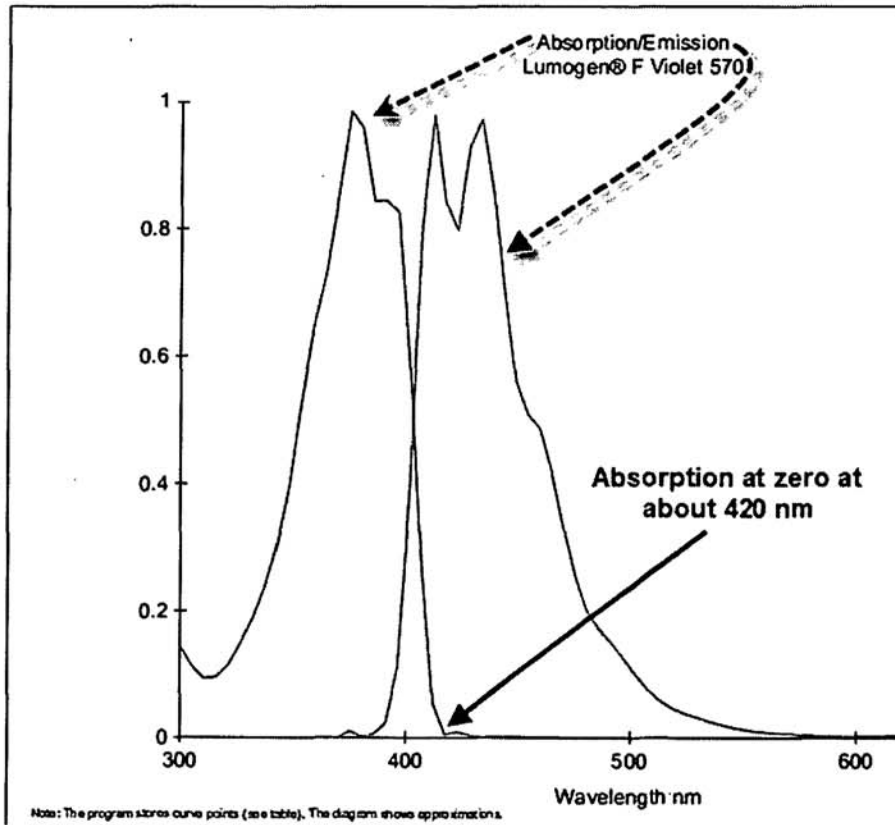

(from BASF Chemical Company)

As shown in the emission spectrum above and as evidenced by the fourth Baretz's Declaration (3/26/2012 ¶ 18), the emission spectra of Luminogen® F Violet 570 and Nichia GaN, blue LED appears to have the **same** emission wavelength range of 380-420 nm. By contrast, the claims require the blue radiation emission from the LED to be **down**-converted (in terms of energy i.e. to longer wavelengths). The equal emission spectra do not appear to allow the claimed **down conversion** of

Art Unit: 3992

**blue** light by at least one of the phosphors used in the '175 patent to produce the blue light portion of the secondary radiation that contributes to the white light, as required by the claims.

Further in this regard, without claiming which phosphors are capable of actually down-converting the **blue** primary radiation to some visible color of light that contributes to the white light produced solely by the secondary radiation, the proposed new and proposed amended claims are not enabled in scope with the disclosure in the '175 specification for failing provide which phosphors are capable of said down-conversion of the claimed **blue** light to blue light of a longer wavelength, which does not appear to be a down-conversion at all.

In summary, if the blue light from the LED is not absorbed by the phosphor (e.g. Luminogen® F Violet 570), then there can be no down-converted radiation from said phosphor to contribute to the blue portion of the secondary radiation that makes the white light, contrary to the claims. In addition, since the blue light is not absorbed by the phosphor, Luminogen® F Violet 570, at least some of the blue light contributing to the white light comes from the LED rather than from the secondary, down-converted radiation, since the phosphor is not absorbing the **blue** radiation from the LED, contrary to the claims.

The remaining claims listed above, depend from one of the independent claims either directly or indirectly and therefore are not enabled for the same reasons as discussed above.

## ***V. Claim Rejections - 35 USC § 102 and 35 USC § 103***

### **A. Statute**

#### **1. 35 USC 102**

The following is a quotation of the appropriate paragraphs of **35 U.S.C. 102** that form the basis for the rejections under this section made in this Office action:

A person shall be entitled to a patent unless –

(b) the invention was patented or described in a printed publication in this or a foreign country or in public use or on sale in this country, more than one year prior to the date of application for patent in the United States.

(e) the invention was described in (1) an application for patent, published under section 122(b), by another filed in the United States before the invention by the applicant for patent or (2) a patent granted on an application for patent by another filed in the United States before the invention by the applicant for patent, except that an international application filed under the treaty defined in section 351(a) shall have the effects for purposes of this subsection of an application filed in the United States only if the

Art Unit: 3992

international application designated the United States and was published under Article 21(2) of such treaty in the English language.

## 2. 35 USC 103

The following is a quotation of **35 U.S.C. 103(a)** which forms the basis for all obviousness rejections set forth in this Office action:

(a) A patent may not be obtained though the invention is not identically disclosed or described as set forth in section 102 of this title, if the differences between the subject matter sought to be patented and the prior art are such that the subject matter as a whole would have been obvious at the time the invention was made to a person having ordinary skill in the art to which said subject matter pertains. Patentability shall not be negated by the manner in which the invention was made.

### **B. Comment regarding new claims 62-99, 149-171, 178, 187, and 188**

Based on the rejection under 35 USC 112(1) above, the rejections over prior art of proposed new claims 62-99, 149-171, 178, 187, and 188 are made to the extent these claims may be deemed enabled. Examiner respectfully maintains that the claims are not enabled, **as written**.

### **C. Stevenson as a base reference**

1. Claims 1, 5, 12, 13, 21, 22, 26, 27, 31-33, 41, 45-47, 55, 59-61, 172, 176, and 178 are rejected under 35 U.S.C. 102(b) as being anticipated over Stevenson, as evidenced by the CRC Handbook.

Proposed amended claim 1 reads,

**[1]** 1. *A light emitting device, comprising:*

**[2]** *at least one single-die semiconductor light-emitting diode (LED) coupleable with a power supply to emit a primary radiation [3] which is the same for each single-die semiconductor LED present in the device, [4] said primary radiation being a relatively shorter wavelength radiation outside the visible white light spectrum; and*

**[5]** *a down-converting luminophoric medium arranged in receiving relationship to said primary radiation, and which in exposure to said primary radiation responsively emits radiation at a multiplicity of wavelengths and in the visible white light spectrum, with said radiation of said multiplicity of wavelengths mixing to produce a white light output, [6] wherein each of the at least one single-die semiconductor light-emitting diode in interaction with luminophoric medium receiving its primary radiation produces white light output.*



Art Unit: 3992

**Feature [1]: 1. A light emitting device**

Stevenson's Fig. 3 (reproduced below) shows a light emitting device, specifically a GaN-based light-emitting diode (Stevenson, title: "Gallium Nitride Metal-Semiconductor Junction Light Emitting Diode").

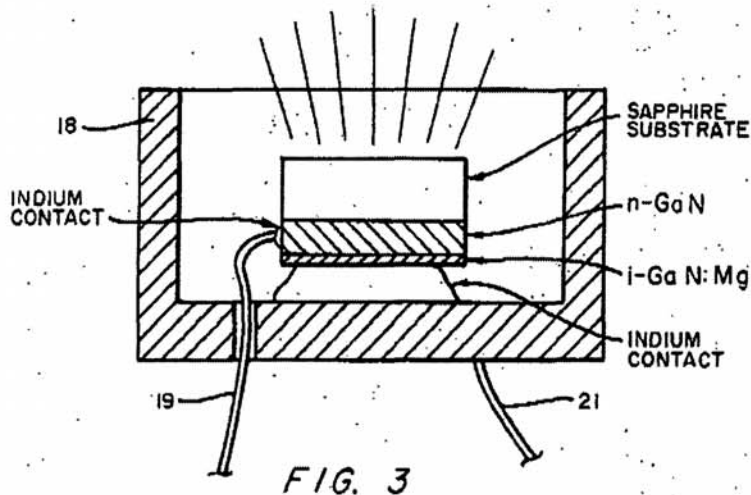

(Stevenson, Fig. 3)

**Feature [2]: at least one single-die semiconductor light-emitting diode (LED) coupleable with a power supply to emit a primary radiation**

Stevenson's Fig. 3 shows a *single-die semiconductor LED* where the semiconductor includes GaN. Fig. 3 also shows that leads **19** and **21** that couple the LED to a power supply. In this regard, Stevenson states,

Referring to FIG. 1, the steps of forming a junction **gallium nitride light emitting diode** are illustrated. A **wafer** or slice of single crystal flame-fusion-grown **sapphire** may be used as the **substrate 11**. A layer of highly n-type **gallium nitride 12** is formed on one surface of the wafer...

(Stevenson, col. 1, lines 58-64; emphasis added)

After the formation of the slice shown in FIG. 1C, the slice is **cut up** or **diced** to form devices of predetermined size.

(Stevenson, col. 2, lines 29-31; emphasis added)

(This passage is provided because Patentee has previously alleged that a "die" must be cut from a larger wafer --a point with which Examiner disagrees. Patentee cannot argue that Stevenson fails to meet its interpretation of a "single-die" because each LED die is cut from a larger wafer.)

Art Unit: 3992

The *primary radiation* emitted by the GaN-based LED is shown in Stevenson's Fig. 4 (reproduced below).

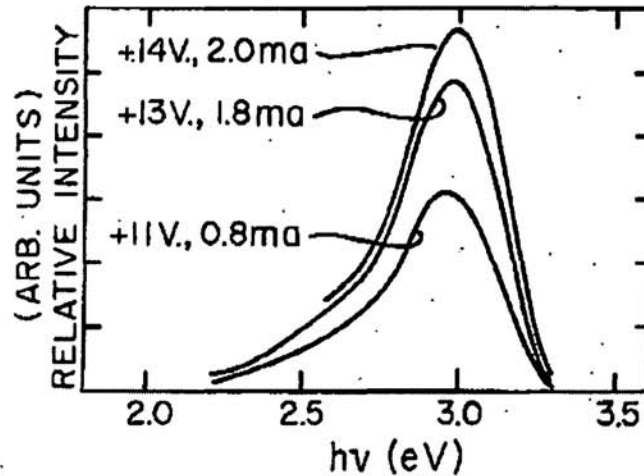

FIG. 4

(Stevenson, Fig. 4)

The range of light energy emitted range from about 2.5 eV to about 3.25 eV. Given that the relations below, the energy can be converted to wavelength.

$$E = H\nu = Hc/\lambda = (4.13566733 \times 10^{-15} \text{ eV}\cdot\text{s})(299792458 \text{ m/s}) / \lambda$$

$$E \text{ (in eV)} \approx 1240 \text{ eV}\cdot\text{nm} / \lambda \text{ (in nm)}$$

Therefore,

$$\lambda \text{ (in nm)} \approx 1240 \text{ eV}\cdot\text{nm} / E \text{ (in eV)}$$

Using the above relation, the range of wavelengths emitted by Stevenson's GaN-based LED is about 496 nm (4960 Å) to 381 nm (3810 Å). The page from the CRC Handbook (reproduced below) shows that the light emitted ranges from blue to ultraviolet.

Art Unit: 3992

## WAVE LENGTHS OF VARIOUS RADIATIONS

	Ångstroms
Cosmic rays .....	0.0005
Gamma rays .....	0.005-1.40
X-rays .....	0.1-100
Ultra violet, below ..	4000
Limit of sun's U.V. at earth's surface .....	2920
Visible spectrum .....	4000-7000
Violet, representative, 4100, limits .....	4000-4240
Blue, representative, 4700, limits .....	4240-4912
Green, representative, 5200, limits .....	4912-5750
Maximum visibility .....	5560
Yellow, representative, 5800, limits .....	5750-5850
Orange, representative, 6000, limits .....	5850-6470
Red, representative, 6500, limits .....	6470-7000
Infra red, greater than .....	7000
Hertzian waves, beyond .....	$2.20 \times 10^6$

(CRC Handbook, 63<sup>rd</sup> Ed., p. E-201)

The peak emission is violet (424 nm to 400 nm), but significant emission is both blue (491 nm to 424 nm) and ultraviolet (less than 4000 Å or 400 nm). Therefore, Stevenson's LED emits light outside the visible spectrum. This is entirely consistent with that which Patentee regards as the invention. In this regard, the '175 patent states,

**Gallium nitride and its alloys** can emit in the spectral range covering the **blue and ultraviolet** extending from wavelengths of **200 nanometers to approximately 650 nanometers**.

(the '175 patent, col. 10, lines 30-33; emphasis added)

Thus, Patentee acknowledges that the range of light emitted by the GaN-based LEDs is a continuum and includes more than a single wavelength or color.

In addition, in all of the declarations of Bruce Baretz (first listed inventor of this patent) indicate that the GaN die emits UV or blue light. (See, e.g. the third Baretz Declaration submitted 3/26/2016 which states,

12. The Exhibit B memorandum of July 30, 1994 identifies the subject matter thereof as "REFERENCE: White Light Light Emitting Diodes (LED)" referring to the white light LED invention that I and Bruce H. Baretz had conceived prior to the date of such memorandum. The memorandum states as follows:

"Duncan -



Art Unit: 3992

Enclosed are some samples of the Lumogen dyes already cast into PMMA sheets. These dyes may be useful, when incorporated into polycarbonate LED lenses, to attenuate and shift the light emission from **UV or Blue (assuming [sic] a GaN die)** to either a green, yellow, or red emission, or some combination of these emissions. An appropriate combination would, in theory, generate white light.

I will see if I can get some information on purchasing these Lumogen dyes already mixed into polycarbonate.

Bruce Baretz"

(Third Baretz Declaration, submitted 3/26/2012, p. 7, ¶ 12; emphasis added)

**Feature [3]:** *which is the same for each single-die semiconductor LED present in the device*

As discussed above, Stevenson includes one or an array of the same GaN-based LEDs:

By use of different phosphors, all the primary colors may be developed from this **same basic device**. An **array** of such devices may be used for color display systems; for example, a solid state TV screen.

(Stevenson, col. 4, lines 5-7; emphasis added)

Therefore, the primary light is the same for each LED.

**Feature [4]:** *said primary radiation being a relatively shorter wavelength radiation outside the visible white light spectrum*

As indicated above, Stevenson's GaN-based LED emits ultraviolet (UV) light (i.e. below 400 nm wavelength) which is necessarily outside the *visible white light spectrum*, and is entirely within the meaning of the '175 patent.

**Feature [5]:** *a down-converting luminophoric medium arranged in receiving relationship to said primary radiation, and which in exposure to said primary radiation responsively emits radiation at a multiplicity of wavelengths and in the visible white light spectrum, with said radiation of said multiplicity of wavelengths mixing to produce a white light output.*

Stevenson discloses a down-converting luminophoric medium including organic and inorganic phosphors to convert the blue-to-UV emitted radiation from the GaN-based LED into visible light to be used for, *inter alia*, color displays and TV's:

Thus, it is seen that there has been provided an improved **light emitting diode** capable of emitting light in the violet **region** of the spectrum. This device may be used as a source of violet light for applications where this spectral range is appropriate. This **light may be converted to lower**

Art Unit: 3992

**frequencies (lower energy)** with good conversion efficiency using **organic and inorganic phosphors**. Such a conversion is appropriate not only to develop **different colors** for aesthetic purposes, but also to produce light in a spectral range of greater sensitivity for the human eye. By use of **different phosphors, all the primary colors may be developed from this same basic device**. An **array** of such devices may be used for **color display systems; for example, a solid state TV screen**.

(Stevenson, paragraph bridging cols. 3-4; emphasis added)

Each of the primary colors is necessarily within the visible white light spectrum, again as evidenced by the CRC Handbook, above; therefore the phosphors for each primary color *responsively emits radiation at a multiplicity of wavelengths and in the visible white light spectrum*.

White light is implicit since a TV must produce white light to properly produce images; therefore, *said radiation of said multiplicity of wavelengths mixing to produce a white light output*.

**Feature [6]:** wherein each of the at least one single-die semiconductor light-emitting diode in interaction with luminophoric medium receiving its primary radiation produces white light output.

It is implicit that each of Stevenson's individual LEDs is capable of producing white light because one of ordinary skill would clearly recognize that the combination of phosphors for the primary colors produces white light and a single LED would be better than separate LED for each primary color, especially since the same GaN-based LED is used. It is also implicit because white is one of the "different colors" of light composed of a mixture of all of the primary colors.

This is all of the features of claim 1.

Proposed amended **claim 5** reads,

5. *A light-emitting device, comprising:*

*at least one single-die semiconductor light-emitting diode (LED) coupleable with a power supply to emit a primary radiation which is the same for each single-die LED present in the device, said primary radiation being a relatively shorter wavelength radiation; and*

*a down-converting luminophoric medium arranged in receiving relationship to said primary radiation, and which in exposure to said primary radiation, **is excited to** responsively emit a secondary, **relatively longer wavelength, polychromatic** radiation, with **separate wavelengths** of said **polychromatic** radiation mixing to produce a white light output, each of the at least one single-die semiconductor light-emitting diode in interaction with*

Art Unit: 3992

*luminophoric medium receiving its primary radiation produces white light output.*

Claim 5 is distinct from claim 1 in that (1) the primary radiation is not required to include radiation outside the visible white light spectrum; (2) the down-converting is required to yield longer wavelengths than that of the primary radiation; and (3) separate wavelengths are required to be produced.

With regard to **difference (1)**, claim 5 is broader in this respect; thus, Stevenson discloses the claimed LED for the reasons indicated in conjunction with claim 1.

With regard to **differences (2) and (3)**, as discussed in rejecting claim 1 above, Stevenson discloses that the blue-to-UV light is down-converted (in terms of energy) to visible light by phosphor (PL) materials, which implicitly includes white light --especially since Stevenson discusses TV's which must have white light. Visible light includes white light which is necessarily polychromatic, as evidenced by the CRC Handbook (i.e. visible light includes a combination of the wavelengths from 700 to 400 nm). Because Stevenson discloses that the phosphors can be used to produce the visible light of "different colors", which includes white light, those of ordinary skill in the art would recognize that the phosphors to which Stevenson refers include those producing white light.

This is all of the features of claim 5.

Proposed amended **claim 12** and **claim 13** read,

*12. A light-emitting device according to claim 5, wherein each single-die semiconductor LED present in the device is on a substrate in a multilayer device structure, and wherein said substrate comprises a material selected from the group consisting of **sapphire**, SiC, and InGaAIN.*

*13. A light-emitting device according to claim 12, wherein said multilayer device structure includes layers selected from the group consisting of silicon carbide, aluminum nitride, **gallium nitride**, gallium phosphide, germanium carbide, indium nitride, and their mixtures and alloys.*

Stevenson's Figs. 2 and 3 show that the *gallium nitride* (GaN) based LED is multilayered, including an n-GaN layer **12**, an i-GaN layer **13** and an indium contact layer **17**, all formed on a sapphire substrate **11**.

Proposed amended **claim 21** and **claim 22** read,

*21. A light-emitting device according to claim 5, wherein each single-die semiconductor LED present in the device comprises a single-die, two-lead gallium nitride based blue light semiconductor LED.*

Art Unit: 3992

*22. A light-emitting device according to claim 5, wherein each single-die semiconductor LED present in the device comprises a single-die two-lead semiconductor LED.*

As noted above in rejecting claim 1, Stevenson discloses a GaN-based LED (Stevenson, Fig. 3) that emits blue-to-UV light (Stevenson, Fig. 4). Fig. 3 also shows the two leads **19, 21** (Stevenson, col. 2, line 51) and therefore reads-on the features of claims 21 and 22.

**Claim 26** reads,

*26. A light-emission device, comprising*  
*a single-die, two-lead semiconductor light-emitting diode emitting radiation;*  
*and*  
*a recipient down-converting luminophoric medium for down-converting the radiation emitted by the light-emitting diode, to a polychromatic white light.*

This claim is significantly broader than claim 22 above. Stevenson discloses each of the features of this claim for the reasons discussed in rejecting claims 1, 5, and 22 above.

Proposed new **claims 27, 41, and 55** read,

*27. The light emitting device of claim 1, wherein the luminophoric medium comprises an inorganic luminophor.*

*41. The light emitting device of claim 5, wherein the luminophoric medium comprises an inorganic luminophor.*

*55. The light emitting device of claim 26, wherein the luminophoric medium comprises an inorganic luminophor.*

As already indicated above, Stevenson states that the luminophor can be organic or inorganic:

This light may be converted to lower frequencies (lower energy) with good conversion efficiency using organic and **inorganic phosphors**.

(Stevenson, col. 3, lines 28-31; emphasis added)

The mixing of specifically inorganic phosphors is also taught by APA, as discussed in detail above.

Proposed new **claims 31-33, 45-47, and 59-61** read,

Art Unit: 3992

31. The light emitting device of claim 27, wherein each said LED comprises material selected from the group consisting of **gallium nitride and its alloys**.

32. The light emitting device of claim 27, wherein each said LED comprises **gallium nitride**.

33. The light emitting device of claim 27, wherein each said LED comprises **gallium nitride alloy**.

45. The light-emitting device of claim 41, wherein each said LED comprises material selected from the group consisting of **gallium nitride and its alloys**.

46. The light-emitting device of claim 41, wherein each said LED comprises **gallium nitride**.

47. The light-emitting device of claim 41, wherein each said LED comprises **gallium nitride alloy**.

59. The light-emission device of claim 55, wherein the light-emitting diode comprises material selected from the group consisting of **gallium nitride and its alloys**.

60. The light-emission device of claim 55, wherein the light-emitting diode comprises **gallium nitride**.

61. The light-emission device of claim 55, wherein the light-emitting diode comprises **gallium nitride alloy**.

As indicated above, Stevenson's Figs. 2 and 3 show that the *gallium nitride* (GaN) based LED is multilayered, including an n-GaN layer **12**, an i-GaN layer **13** and an indium contact layer **17**, all formed on a sapphire substrate **11**. The term "n-GaN" is undoped or pure; therefore; Stevenson's LED includes gallium nitride:

A layer of highly n-type gallium nitride **12** is formed on one surface of the wafer **11** by transporting gallium as its gaseous monochloride and introducing nitrogen into the growth zone in the form of ammonia, both at an elevated temperature (approximately 900°-950°C.) whereby there is epitaxially grown the **GaN layer 12**.

(Stevenson, col. 1, lines 61-67; emphasis added)

The i-GaN is made by alloying with magnesium (Mg); therefore, Stevenson's LED includes GaN alloys:

The dopant atoms compensate the normally n-type growth to form a substantially intrinsic **GaN:Mg layer 13**. The layer **13** forms an i-n junction



Art Unit: 3992

14 with the layer 12. The **magnesium** is added by placing magnesium in a graphite crucible and maintaining it at approximately 710°C while passing thereover nitrogen gas. This transports the elemental **magnesium** atoms into the growth zone where they deposit as an impurity or dopant with the gallium nitride to form the intrinsic **GaN:Mg region 13**.

(Stevenson, col. 2, lines 10-19; emphasis added)

Proposed new **claims 172 and 176** read,

172. The light-emitting device of claim 5, wherein the secondary, relatively longer wavelength, polychromatic radiation comprises a broad spectrum of frequencies.

176. The light-emission device of claim 26, wherein radiation down-converted by the recipient down-converting luminophoric medium comprises a broad spectrum of frequencies.

As noted above, visible light including each of the primary colors is a broad spectrum of frequencies, as evidenced by the CRC Handbook. Therefore, the secondary, down-converted radiation emitted from Stevenson's light emitting device includes *a broad spectrum of frequencies*.

Proposed new **claim 178** reads,

178. A light-emitting device, comprising:

a single-die gallium nitride based semiconductor blue light-emitting diode (LED) coupleable with a power supply to emit a primary radiation, said primary radiation being a relatively shorter wavelength blue light radiation; and

a down-converting luminophoric medium arranged in receiving relationship to said primary radiation, and which in exposure to said primary radiation, is excited to responsively emit a secondary, relatively longer wavelength, polychromatic radiation, with separate wavelengths of said polychromatic radiation mixing to produce a white light output.

Patentee indicates that claim 178 is claim 5 with the exception that the terminology "at least one" has been removed and that the LED is now limited to a GaN-based blue-light emitting diode (Patentee's Remarks dated 3/26/2012, p. 63). For the same reasons as indicated above, Stevenson anticipates this claim because the LED is a GaN-based LED that emits-blue-to-UV light and therefore emits blue light.

Art Unit: 3992

2. Claims 1, 5, 12, 13, 21, 22, 26, 27, 31-33, 41, 45-47, 55, 59-61, 172, 176, and 178 are rejected under 35 U.S.C. 103(a) as being unpatentable over Stevenson in view of any of Pinnow, Menda, and Admitted Prior Art (APA).

The prior art of Stevenson, as explained above, is believed to disclose each of the features of claims 1, 5, 12, 13, 21, 22, 26, 27, 31-33, 41, 45-47, 55, 59-61, 172, 176, and 178.

However, if it is believed that Stevenson does not explicitly disclose that the luminophoric medium includes all of the phosphors for each primary color such that white light is produced by *each* of the GaN-based LEDs --as required by the proposed amended feature of claims 1, 5, 26, and proposed new claim 178, above-- then this may be a difference between Stevenson and claims 1, 5, 26, and 178. As claimed,

wherein each of the at least one single-die semiconductor light-emitting diode in interaction with luminophoric medium receiving its primary radiation produces white light output. (claim 1)

each of the at least one single-die semiconductor light-emitting diode in interaction with luminophoric medium receiving its primary radiation produces white light output. (claim 5)

a recipient down-converting luminophoric medium for down-converting the radiation emitted by the light-emitting diode, to a polychromatic white light. (claim 26)

a down-converting luminophoric medium arranged in receiving relationship to said primary radiation, and which in exposure to said primary radiation, is excited to responsively emit a secondary, relatively longer wavelength, polychromatic radiation, with separate wavelengths of said polychromatic radiation mixing to produce a white light output (claim 178)

Any of Pinnow, Menda, and APA renders this feature obvious for the reasons indicated below.

Pinnow, like Stevenson, teaches a display wherein an argon laser (instead of an LED) is used to produce the primary visible or UV light that is down-converted by a **mixture of phosphors** into visible, secondary light of longer wavelength light which explicitly includes white light:

A single color display is produced by projection using a scanning laser beam operating in the **visible** or **ultraviolet** and a photoluminescent screen which emits in the visible. **Combinations of phosphors** may be employed to simulate **white** or desired colors.

(Pinnow, abstract)

Art Unit: 3992

Pinnow's Fig. 3 shows the display device including the laser **10** and one example of a phosphor screen **15**. The primary light from the laser **10** is down-converted by phosphor screen **15** to produce visible light. Importantly, Pinnow teaches that phosphors for each primary color can be mixed together in a **resin** to produce **white** light:

In this description, use will be made of the term "colorant" or "organic colorant." It is to be understood that this term includes photoluminescent organic dyes and pigments. **Pigments** are particularly useful and may be formed by **dissolving a dye in an organic resin solution which is subsequently condensed**. It is known that luminescent efficiency in certain cases may be enhanced if the dye is absorbed on a colloid which may take the form of gell [sic] fibers or particles of high molecular weight polymers.

(Pinnow, paragraph bridging cols. 1-3; emphasis added)

The invention is broadly premised on the use of such organic colorants. Monochromatic displays result from use of **homogeneous phosphor screens**. These may be present as **self-supporting members** or as **coatings**, and they may be made up on **one or any combination of colorants required to produce the desired balance**.

(Pinnow, col. 2, lines 15-20; emphasis added)

A black and **white** display can be achieved by scanning a monochromatic laser beam on a viewing screen that is **coated with an appropriate blend of phosphors** and direct scattering materials such as powdered MgO or talc. For example, a combination of scattered light from a **blue argon-ion laser beam (4,880 A.)** [i.e. **visible** light] and blue-to-red converted light from either of the Rhodamine dye phosphors can produce a **white** appearance since a straight line connecting these primaries on the chromaticity diagram passes very near to illuminant C.

A combination of **more than two primaries** can also be used to produce **white**. As an example, a **Cd-He laser** beam which illuminates a correctly proportioned mixture of MgO and dye phosphors 3,484 A. and 3,485 A. [i.e. **ultraviolet** light] can be used to achieve a white appearance. Alternately, MgO may be replaced by pyrene-containing materials or 7-diethyl amino, 4-methyl coumarin-containing materials (blue-to-blue and ultraviolet-to-blue converting phosphor, respectively, to completely eliminate speckle).

Regardless of how many phosphors are used, it is apparent from the chromaticity diagram that a necessary condition for achieving a true white is that the illuminating laser beam have a **wavelength of approximately 4,950 A. or shorter**. Otherwise, it is impossible to include illuminant C within a polygon whose primaries are the source and any combination of longer wavelengths that can be achieved by down-conversion of frequency. Fortunately, the argon-ion laser satisfies this necessary condition.

(Pinnow, col. 3, lines 24-55; emphasis added)

(It is noted that Pinnow uses "A." for "angstrom", which is properly, instead, Å.)



Art Unit: 3992

It is important to note in the final paragraph from Pinnow excerpted above, Pinnow tells those of ordinary skill that **any primary radiation can be used so long as its wavelength is 4950 Å (495 nm) or shorter**, providing examples of both **blue** and **UV** light sources for the primary light that is down-converted into visible light. Stevenson's GaN-based LED meets this criteria, as discussed above. Stevenson's GaN-based LED emits blue-to-UV light from about 496 nm (4960 Å) to 381 nm (3810 Å). Therefore, those of ordinary skill using the phosphor mixtures taught by Pinnow have a certain expectation of success. Pinnow shows that the results of illuminating the phosphor mixture with UV light or blue light (i.e. shorter than 4950 Å) produces entirely predictable results in making white light of any shade desired.

It would have been obvious to one of ordinary skill in the art, at the time of the invention to use Pinnow's phosphor mixtures, made as coating on a screen or as a self-standing screen (Pinnow, *id.*) as the phosphor mixture in Stevenson, in order to produce a white display. Because Stevenson wishes to produce color displays such as TVs but is silent as to the phosphors needed to do this, one of ordinary skill would use known material known to work for the intended purpose.

Thus, Stevenson modified to ensure a mixture of phosphors is used, ensures that each of the at least one single-die semiconductor light-emitting diode in interaction with luminophoric medium [phosphor mixture] receiving its primary radiation produces white light output, as newly claimed in proposed amended claim 1, and as similarly claimed in claims 5, 26, and 178.

Similar to both Stevenson and Pinnow, Menda is drawn to a display device. Like both Stevenson and Pinnow, Menda teaches that the backlight for the display is white light produced by using a source of UV light (which may be a solid state pn junction or MOS junction) to produce the primary UV light that is down-converted by phosphors into visible, secondary light is white light. In this regard, Menda states,

In the above embodiment, an organic PL element has been realized using a ZnO ultraviolet light emitting element having a schottky junction structure. Likewise, the green light emitting organic PL element can also be realized by using a **solid ultraviolet light emitting element** having a structure of a **pn junction, MOS [Metal-Oxide-Semiconductor] junction** or the like. Further, light having colors other than green can also be emitted by changing the type of the organic coloring matter doped into the PL luminescent layer 22. Further, the amount of luminescence from the PL luminescent layer 22 can be regulated by regulating the amount of voltage or current applied to the ultraviolet light emitting element.

(Menda translation, ¶ [0018], p. 6, lines 1-11; emphasis added)

[0021] **Fig. 4** shows an example in which a PL [PhotoLuminescent] element according to the present invention has been applied to a backlight of a **liquid crystal display**. In the drawing, numeral **41** designates a glass substrate

Art Unit: 3992

transparent to ultraviolet light. An **ultraviolet light emitting element 42 as described in the first embodiment** is provided on one side of the glass substrate **41**. Further, a **blue PL luminescent layer 43**, a **green PL luminescent layer 44**, and a **red PL luminescent layer 45** as described in the second embodiment are stacked on the other side of the glass substrate **41**.

[0022] As shown in the drawing, a **liquid crystal display device 50** is stacked on the PL luminescent element having the above construction. ...

[0023] In the above embodiment, individual PL luminescent layers **43 to 45** of three primary colors are **excited by ultraviolet light emitted from the ultraviolet light emitting element 42** and emit respective lights, and these **three primary colors are mixed together** to provide a **white light**. The **white light** thus obtained is applied as a backlight of the liquid crystal display device **50** through the first glass substrate **51**. Also in this embodiment, a deterioration in the PL luminescent layers **43 to 45** can be avoided, and the service life of the PL luminescent layers **43 to 45** can be prolonged.

(Menda translation, p. 7; emphasis added)

Menda's Fig. 4 (reproduced below) shows the UV light emitting element **42** and the photoluminescent (PL) layers **43, 44, 45**, one for each of the primary colors specifically a liquid crystal display having a backlight (Menda translation, p. 7, ¶ [0021]).

[Fig 4]

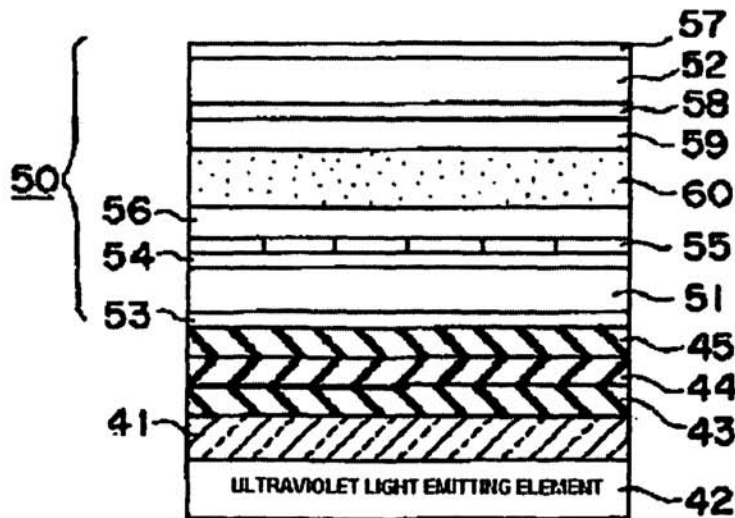

(Menda, Fig. 4)

It would have been obvious to one of ordinary skill in the art, at the time of the invention to use Menda's three PL layers **43, 44, 45** on UV-transparent glass **41** as the phosphor set-up in Stevenson, in order to produce a white display. Because Stevenson wishes to produce color displays such as TVs but is silent as to the

Art Unit: 3992

phosphors needed to do this, one of ordinary skill would use known materials known to work for the intended purpose.

Because each of Stevenson's GaN-based LEDs would pass through all of the PL layers, each LED would produce white light. Thus, Stevenson modified according to Menda to use Menda's phosphor layers **43, 44, 45**, on UV-transparent glass **41**, ensures that each of the at least one single-die semiconductor light-emitting diode in interaction with luminophoric medium receiving its primary radiation produces white light output, as newly claimed in proposed amended claim 1, and as similarly claimed in claims 5, 26, and 178.

Finally, the '175 patent is replete with admitted prior art indicating that it was well known to mix together phosphors, one for each of the primary colors, to produce white light output. For example, the '175 patent states,

It is well known that so-called **fluorescent lamps provide white light** illumination. In a fluorescent lamp, the Hg vapor in the vacuum tube is excited by an electrical discharge. The excited Hg atoms emit light, **primarily in the ultraviolet region** (e.g., 254 nm, 313 nm, 354 nm), which is absorbed by the **inorganic phosphors coating the inside walls of the tube**. The phosphors then emit light. These inorganic phosphors are designed as such to offer white light emission by "down-converting" (i.e., transforming a higher frequency, shorter wavelength form of energy to a lower frequency, longer wavelength form of energy) the ultraviolet emissions of the excited states of atomic Hg into a **broad spectrum** of emitted light which appears as **white** to the observer. **However, these light emitting devices are not solid-state, ...**

(the '175 patent, col. 3, lines 40-53; emphasis added)

Thus, the '175 teaches that the missing part is **not** the mixed phosphors but is, instead, the solid-state light emitting devices, e.g. LEDs. **But** Stevenson --20 years earlier-- already did this. Stevenson exchanged the UV light from electrically-excited Hg vapor with a **solid-state** GaN-based LED and used phosphors --just as in a fluorescent bulb-- to down-convert the blue-to-UV light to any other color and white light (Stevenson, paragraph bridging cols. 3-4, excerpt above).

The '175 patent discusses other mixed, inorganic phosphor systems that produce white light and then acknowledges the following:

While the devices in the above examples vary in concept and construction, they demonstrate the utilization of **red, green and blue fluorescent materials**, all inorganic in composition, which when excited by **photons** or electron beams, can release multiple wavelengths of **secondary light emission** (luminescence of either fluorescent or phosphorescent character) to exhibit **white light** to the observer. This is generally true, even if microscopic domains of discrete colored light emission can be observed on the Lambertian surface of the light emitting device.

Art Unit: 3992

(the '175 patent, col. 4, lines 32-41; emphasis added)

The '175 patent admits that it is known in the art to mix phosphors together to produce white light from a **single** primary source of light. Again, all that is lacking is the LED, but Stevenson teaches this as well as explicitly stating to use organic or inorganic phosphors to produce visible light. Thus the only thing purported to be inventive in the '175 patent, the LED, was known 20 years before the '175 patent. Everything else, i.e. the phosphors is old and notoriously well known.

Another example of single white-light-emitting device discussed in the '175 patent's APA is the "thin film organic electroluminescent cell":

**White light emission** from thin film organic electroluminescent cells based on poly(vinylcarbazole PVK) thin films on ITO-coated glass has also been recently reported. ... It is well known that the excited carbazole moiety within the polymer aggregates in the excited state leads to **blue excimer emission**, in the absence of quenchers or dopants. In the example of the organic Mg:Ag:Alq:TAZ:doped PVK:ITO:Glass electroluminescent device, the quenchers of excimeric emission, are the **dopants blue emitting** 1,1,4,4-tetraphenylbuta-1,3-diene (TPB), **green emitting** 7-diethylamino-3-(2-benzothiazoyl)coumarin (Coumarin-6), and **red emitting** dicyanomethylene-2-methyl-6-p-dimethylaminostyryl-4H-pyran (DCM-1).

(the '175 patent, col. 5, lines 21-44; emphasis added)

Thus, the primary "blue excimer emission" is converted into each of the primary color by dopants that are **mixed** together to produce white light by the same cell.

The '175 patent also acknowledges that others have produced white light using LEDs by mixing wavelengths of light from **three different** LEDs, each one producing a separate "primary" color:

Given the desirability of white light displays (e.g., commercial bank "time and temperature" message boards, stadium scoreboards), considerable effort has been expended to produce white light LEDs. Although the recent availability of the blue LED makes a full color, and by extension a white light display realizable, conventionally it has been considered that such a display would require multiple LEDs. The **multiple** LEDs would be then incorporated into complicated and expensive LED modules to obtain the required broad band illumination necessary to provide white light. Even if a discrete LED lamp were constructed that provides white illumination (as opposed to the utilization of a **multitude of single die, single color discrete LED lamps in a module or sub-assembly**), the current state of the art requires the utilization of multiple LED dies and typically at least four electrical leads to power these dies. U.S. Pat. No. 4,992,704 issued to Stinson teaches a variable color light emitting diode having a unitary housing of clear molded solid epoxy supporting **three LED dies characterized as producing color hues of red, green and blue**, respectively. There have been some recent introductions of commercial "full-color" LED lamps, that are essentially **discrete lamps** which afford a means of producing white light. All currently available examples of



Art Unit: 3992

such lamps contain a minimum of three LED dies (or chips)--**one red, one green and one blue**, encapsulated in a single epoxy package.

(the '175 patent, col. 2, lines 25-50; emphasis added)

What the '175 patent does **not**, however, acknowledge is that Stevenson --**20 years before** the '175 patent-- already produced colored or white light by down-converting blue-to-UV light from the **same** GaN-based LED (rather than three separate LEDs, one emitting each primary color) by using organic or inorganic phosphors (Stevenson, paragraph bridging cols. 3-4; excerpt above).

All that Stevenson **may** not disclose is whether or not the phosphors are mixed together to produce white light. Given the APA discussed above, one would be hard-pressed to believe that it would escape the mind of the routineer in the lighting arts to mix the phosphors together to produce white light. Nonetheless, even if it is not implicit in Stevenson alone to mix the phosphors to produce white light, given the ample evidence in the '175 patent's APA for the desire to produce white light from a **single** light-emitting device by mixing phosphors together, (e.g. fluorescent bulbs, EL devices, *supra*), it would have been entirely obvious to one of ordinary skill at the time of the invention to mix together the phosphors in Stevenson to produce white light output from each single GaN-based LED because the '175 patent's APA admits that this is both highly desired and notoriously well known. In addition, one **benefit** would be to produce white light from a **single** LED rather than from **multiple** LEDs, thereby making the cost of white light less expensive, as clearly indicated by the APA.

Thus, Stevenson modified according to APA to use known phosphor mixtures ensures that each of the at least one single-die semiconductor light-emitting diode in interaction with luminophoric medium receiving its primary radiation produces white light output, as newly claimed in proposed amended claim 1, and as similarly claimed in claims 5, 26, and 178.

3. Claims 1, 3-5, 12, 13, 21, 22, 26, 62, 63, 69-72, 74, 76-79, 100, 101, 106-110, 112, 114-116, 118, 124-126, 128, 130-132, 134, 137, 140-142, 145-147, 172, 176, and 178 are rejected under 35 U.S.C. 103(a) as being unpatentable over Stevenson in view of Pinnow and Nakamura.

The prior art of Stevenson, as explained above, is believed to disclose each of the features of claims 1, 5, 12, 13, 21, 22, 26, 172, 176, and 178.

To the extent it is believed that claims 1 and 26 (and their dependent claims) exclude light outside the visible spectrum --a point to which Examiner disagrees-- and because Stevenson indicates that the GaN-based LED emits light "in a violet region of the spectrum" --albeit including emission wavelengths running from blue-to-UV (Stevenson, Fig. 4; col. 3, lines 24-26)-- then this may be a difference between claims 1 and 26, and Stevenson. To the extent it is believed that claims 21

Art Unit: 3992

and 178 exclude light other than blue light, then this may be a difference between claims 21 and 178, and Stevenson. Note, however, just as the commercially available GaN-based LED from Nichia used in the '175 patent (col. 9, lines 10-18) emits a significant amount of both UV and violet light, Patentee cannot argue that the LED emits **only** light the visible spectrum, as this would contradict the '175 patent and the inventor Bartez's Declaration dated 3/26/2012, paragraph 18, which shows the Nichia LED emits light from UV to blue, just as does Stevenson's.

Nakamura teaches GaN-based LEDs and lasers that emit both blue and UV light. (In fact, one LED indicated as suitable in the '175 invention is a GaN LED from Nichia Chemicals, to which Nakamura is assigned. See the '175 patent, col. 9, lines 10-18. Thus, Patentee admits to using known GaN-based LED for the instant invention.)

First, Nakamura indicates that GaN-based LED emitting light outside the visible white light spectrum are known in the art:

**Jpn. Pat. Appln. KOKAI Publication No. 4-68579** discloses a double-heterostructure having a p-type **GaInN** clad layer formed on an oxygen-doped, n-type **GaInN** light-emitting layer. ... The emission wavelength of the light-emitting device having this double-heterostructure is **365 to 406 nm**.

(Nakamura, col. 2, lines 7-14; emphasis added)

UV light is light less than 400 nm as evidenced by the CRC Handbook, *supra*.

In regard to its LEDs and lasers, Nakamura states the following:

The semiconductor device of the present invention includes a **light-emitting diode (LED)** and a **laser diode (LD)**.

(Nakamura, col. 4, lines 9-11)

It is still another object of the present invention to provide an **ultraviolet to red light-emitting device** having a wavelength in the region of **365 to 620 nm**.

(Nakamura, col. 2, lines 30-33; emphasis added)

FIG. 12 shows a structure of a **laser diode 40** having a double-heterostructure of the present invention.

The **laser diode 40** has a double-heterostructure constituted by an impurity-doped **In<sub>x</sub>Ga<sub>1-x</sub>N active layer 18** described above in detail in association with the light-emitting diode, and two clad layers sandwiching the active layer **18**, i.e., an n-type gallium nitride-based compound semiconductor layer **16** and a p-type gallium nitride-based compound semiconductor layer **20**, as described above. A buffer layer **14** described above in detail is formed on a substrate **12** described above in detail. An n-type gallium nitride layer **42** is formed on the buffer layer **14**, providing a contact layer for an n-electrode described below.

Art Unit: 3992

(Nakamura, col. 11, line 61 to col. 12, line 6; emphasis added)

Nakamura shows that the wavelength of the LED or LD can be controlled by controlling the dopant:

In the light-emitting device of the present invention, when the value of  $x$  in  $\text{In}_x\text{Ga}_{1-x}\text{N}$  of the light-emitting layer is close to 0, the device emits **ultraviolet** light. When the value of  $x$  increases, the emission falls in the longer-wavelength region. When the value of  $x$  is close to 1, the device emits red light. When the value of  $x$  is in the range of  $0 < x < 0.5$ , the light-emitting device of the present invention emits **blue** to yellow light in the wavelength range of **450** to 550 nm.

(Nakamura, col. 4, lines 52-59; emphasis added)

Nakamura provides numerous examples of LEDs emitting blue light (Examples 1-28 at cols. 13-20) including an emission **peak** value at, *inter alia*, 400 nm (Nakamura, col. 14, lines 64-65) at 405 nm (*id.*, claim 18, line 67), 430 nm (*id.*, col. 14, lines 51-52), and 480 nm (*id.*, col. 13, lines 40-42).

The peak emission wavelength at 400 nm and 405 nm show that the LEDs of these examples emit primarily **ultraviolet** light, as evidenced by the CRC Handbook. Similarly, those LEDs having peak emission at 430 nm and 480 nm emit primarily **blue** light.

It would have been obvious to one of ordinary skill in the art, at the time of the invention to substitute Stevenson's GaN-based LED with either the known UV light emitting or blue light emitting LED GaN-based LED disclosed in Nakamura (inventive or already known). This can be seen as simple substitution of one known element (Stevenson's GaN-based LED) for another known element (Nakamura's GaN-based LED) to obtain predictable results (as evidenced by Pinnow) and is one of the rationales identified by the Supreme Court in *KSR International Co. v. Teleflex Inc.*, 550 U.S. \_\_\_, \_\_\_, 82 USPQ2d 1385, 1395-97 (2007). (See MPEP 2143, Rationale B.)

Both Stevenson's and Nakamura's LED emit light in the same general region of the spectrum and are GaN-based, so the material is essentially the same. Nonetheless, it is the wavelength of light emitted that counts, and Pinnow teaches that the wavelength of light need only be shorter than 495 nm (4950 Å) to be effective to be converted by the mixture of phosphors to white light.

In regard to the predictability, as already noted above, Pinnow teaches that any wavelength of primary radiation can be down-converted by the mixture of phosphors to produce white light so long as the wavelength is less than 4950 Å (495 nm):

Regardless of how many phosphors are used, it is apparent from the chromaticity diagram that a necessary condition for achieving a true white is

Art Unit: 3992

that the illuminating laser beam have a **wavelength of approximately 4,950 Å. or shorter**. Otherwise, it is impossible to include illuminant C within a polygon whose primaries are the source and any combination of longer wavelengths that can be achieved by down-conversion of frequency. Fortunately, the argon-ion laser satisfies this necessary condition.

(Pinnow, col. 3, lines 24-55; emphasis added)

(It is noted that Pinnow uses "A." for "angstrom", which is properly, instead, Å.)

Thus, Pinnow teaches those of ordinary skill that shifting the peak maximum of the LED in Stevenson from violet to either blue (slightly longer wavelength) or ultraviolet (slightly shorter wavelength), by using one of Nakamura's GaN-based LED (inventive or known) would yield entirely predictable results of white light emission with the down-converting phosphor mixture. The predictability results from using Nakamura's LEDs that emit light (UV or blue) having a wavelength of less than 4950 Å (495 nm).

This is all of the features of claims 1, 21, 26, and 178.

**Claims 3 and 4** read,

3. *A light-emitting device, comprising:*

*a semiconductor **laser** coupleable with a power supply to emit a primary radiation having a relatively shorter wavelength outside the **visible** light spectrum; and*

*a down-converting luminophoric medium arranged in receiving relationship to said primary radiation, and which in exposure to said primary radiation responsively emits polychromatic radiation in the visible light spectrum, with different wavelengths of said polychromatic radiation mixing to produce a white light output.*

4. *A light-emitting device according to claim 3, wherein said semiconductor laser includes an active material selected from the group consisting of III-V alloys and II-VI alloys.*

Claim 3 is distinguished from claim 1 in that (1) a *semiconductor **laser*** is required versus a *single-die semiconductor LED*; (2) the primary radiation is required to be outside the **visible** light spectrum, as opposed to outside the visible **white** light spectrum; and (3) the wording associated with the luminophoric medium.

Each of these features has been addressed above. Nakamura discloses a GaN-based laser diode **40** (Fig. 12) capable of producing either blue or UV light, UV light being outside the visible white light spectrum. The GaN-based LED and LD are made from GaN alloys, such as  $\text{In}_x\text{Ga}_{1-x}\text{N}$  (i.e. a *III-V alloys*), as required by claim 4. In addition, Pinnow teaches that UV **laser** light or blue **laser** light is down



Art Unit: 3992

converted by a mixture of phosphors to produce white light. Therefore, those of ordinary skill in the art know that substituting Stevenson's GaN-based LED with Nakamura's GaN-based laser diode will yield the same predictable result of white light by the phosphor mixture, for the same reasons as discussed above. In other words, it is the wavelength of light not whether or not the device emits incoherent or coherent light.

The reason for using Nakamura's GaN-based laser diode in place of Stevenson's GaN-based LED is the same as for claims 1 and 26, discussed above.

Further regarding **claim 5**, there is no requirement that the light be outside the visible white light spectrum, but substituting Stevenson LED with those of Nakamura would still read on claim 5 because the secondary radiation emitted by the phosphor mixture of Stevenson/Pinnow would be white light.

Further regarding **claims 12 and 13**, Nakamura, like Stevenson, fabricates the LED on sapphire substrates (Nakamura, col. 12, line 42) and the LEDs are multilayered (Nakamura's Figs. 1, 11, 12), so substitution of Stevenson's GaN LED with those in Nakamura, still reads on the features of claims 12 and 13.

Further regarding proposed amended **claim 21 and claim 22**, both Stevenson and Nakamura disclose that the LED have two leads. Thus again, substitution of Stevenson's GaN LED with those in Nakamura, still reads on the features of proposed amended claim 21 and claim 22.

Further regarding proposed new **claims 172 and 176**, because Pinnow teaches plural phosphors making white light, the secondary, down-converted radiation of the Stevenson/Nakamura/Pinnow light-emitting device has a *broad spectrum of frequencies*.

Further regard proposed new **claim 178**, because Pinnow teaches plural phosphors making white light, the secondary, down-converted radiation of the Stevenson/Nakamura/Pinnow light-emitting device emits white light from the blue or UV LED, as explained above.

Proposed new **claim 62** reads,

62. A light-emitting device, comprising:

at least one single-die **gallium nitride based semiconductor blue light-emitting diode (LED)** coupleable with a power supply to emit a primary radiation which is the same for each single-die LED present in the device, said primary radiation being a relatively shorter wavelength blue light radiation; and

a down-converting luminophoric medium arranged in receiving relationship to said primary radiation, and which in exposure to said primary radiation, is

Art Unit: 3992

excited to responsively emit a secondary, relatively longer wavelength, polychromatic radiation, with separate wavelengths of said polychromatic radiation mixing to produce a white light output, wherein each of the at least one single-die gallium nitride based semiconductor blue light-emitting diode in interaction with luminophoric medium receiving its primary radiation produces white light output,

and wherein the light-emitting device comprises one or more compatible characteristics selected from the group consisting of:

(i) the luminophoric medium being arranged **about** the single-die light-emitting diode;

(ii) the luminophoric medium being **contiguous to** the single-die light-emitting diode;

(iii) the single-die light-emitting diode comprising side surface and the luminophoric medium being in **laterally spaced relationship to said side surface**;

(iv) the luminophoric medium being dispersed **in polymer or glass**; and

(v) the luminophoric medium being **on polymer or glass**.

Claim 62 is coextensive with claim 5, as indicated by Patentee (Remarks dated 3/26/2012, pp. 28-29). Claim 62 is distinguished from claim 5 in (1) the LED is required to be a blue-light-emitting GaN-based LED and (2) the one or more *compatible characteristics*. The substitution of Stevenson's blue-to-UV-light-emitting GaN-based LED with Nakamura's blue-light-emitting GaN-based LEDs was discussed above and is obvious for the same reasons. The luminophoric medium (phosphor mixture of Pinnow) is necessarily *about* the LED; otherwise, it would not interact with the primary radiation. In addition, Pinnow teaches that the phosphor mixture meets either of iv and v:

In this description, use will be made of the term "colorant" or "organic colorant." It is to be understood that this term includes photoluminescent organic dyes and pigments. **Pigments** are particularly useful and may be formed by **dissolving a dye in an organic resin solution [i.e. a polymer] which is subsequently condensed**. It is known that luminescent efficiency in certain cases may be enhanced if the dye is absorbed on a colloid which may take the form of gell [sic] fibers or particles of high molecular weight polymers.

(Pinnow, paragraph bridging cols. 1-3; emphasis added)

The invention is broadly premised on the use of such organic colorants. Monochromatic displays result from use of **homogeneous phosphor screens**. These may be present as **self-supporting members** or as

Art Unit: 3992

**coatings**, and they may be made up on **one or any combination of colorants required to produce the desired balance.**

(Pinnow, col. 2, lines 15-20; emphasis added)

Proposed new claims 63, 68-72, and 74 read,

63. The light-emitting device of claim 62, comprising the luminophoric medium being arranged **about** the single-die light-emitting diode.

68. The light-emitting device of claim 62, comprising the single-die light-emitting diode being arranged to **directly impinge primary radiation on** the luminophoric medium.

69. The light-emitting device of claim 62, comprising the single-die light-emitting diode and luminophoric medium being arranged **without intermediate material therebetween.**

70. The light-emitting device of claim 62, comprising the luminophoric medium being **dispersed in polymer** or glass.

71. The light-emitting device of claim 70, comprising the luminophoric medium being **dispersed in polymer about** the single-die light-emitting diode.

72. The light-emitting device of claim 70, comprising the luminophoric medium being in a **homogeneous** composition.

74. The light-emitting device of claim 62, comprising the luminophoric medium being **on polymer** or glass.

As discussed above, Pinnow teaches that the phosphor can be a coating on a screen or can be homogeneously dispersed in a resin (i.e. polymer) to make a screen. The screen is in spaced relationship to the primary source of radiation without intermediate material therebetween and the primary radiation directly impinges the screen and therefore the phosphor mixtures that produce white light in response to the primary radiation.

It would have been obvious to one of ordinary skill in the art, at the time of the invention to orient Pinnow's phosphor mixture screens (whether coatings or dispersed within the screen) without material and to allow direct impingement by Stevenson/Nakamura's LED, as a matter of design choice. In other words, it is common sense to place the phosphor mixture to make the most advantageous use of the primary radiation, as shown in Pinnow.

Proposed new **claims 76-78** read,

Art Unit: 3992

76. The light-emitting device of claim 62, wherein the single-die light-emitting diode comprises gallium nitride and its alloys.

77. The light-emitting device of claim 62, wherein the single-die light-emitting diode comprises at least one of gallium nitride, indium gallium nitride, aluminum gallium nitride, and aluminum gallium indium nitride.

78. The light-emitting device of claim 62, wherein the at least one single-die gallium nitride based semiconductor blue light-emitting diode comprises only one single-die gallium nitride based semiconductor blue light-emitting diode.

As indicated above, Nakamura teaches GaN and its alloys make the blue-light-emitting LEDs; thus, modification of Stevenson to use Nakamura's LEDs already includes the features of these claims.

Proposed new **claim 79** reads,

79. The light-emitting device of claim 62, comprising a light-emitting diode lamp.

Stevenson's or Stevenson modified according to Nakamura includes a single LED and therefore includes a lamp.

Proposed new **claim 100** reads,

100. A light-emission device, comprising

a single-die, two-lead **gallium nitride based** semiconductor **blue** light-emitting diode emitting radiation; and

a recipient down-converting luminophoric medium for down-converting the radiation emitted by the light-emitting diode, to a polychromatic white light, wherein the light-emission device comprises one or more compatible characteristics selected from the group consisting of:

(i) the luminophoric medium being arranged **about** the single-die light-emitting diode;

(ii) the luminophoric medium being **contiguous to** the single-die light-emitting diode;

(iii) the single-die light-emitting diode comprising side surface and the luminophoric medium being in **laterally spaced relationship to said side surface**;

(iv) the luminophoric medium being dispersed **in polymer or glass**; and

Art Unit: 3992

(v) the luminophoric medium being **on polymer or glass**.

Claim 100 is coextensive with claim 26, as indicated by Patentee (Remarks dated 3/26/2012, pp. 40-41). Claim 100 differs from claim 26 in the same ways that claim 62 is distinguished from claim 5. Therefore claim 100 is obvious for the same additional reasons as indicated above in conjunction with claim 62.

Proposed **new claims 101, 106-110, and 112** read,

101. The light-emission device of claim 100, comprising the luminophoric medium being arranged **about** the single-die light-emitting diode.

106. The light-emission device of claim 100, comprising the single-die light-emitting diode being arranged to **directly impinge** primary radiation on the luminophoric medium.

107. The light-emission device of claim 100, comprising the single-die light-emitting diode and luminophoric medium being arranged **without intermediate material** therebetween.

108. The light-emission device of claim 100, comprising the luminophoric medium being **dispersed in** polymer or glass.

109. The light-emission device of claim 108, comprising the luminophoric medium being **dispersed in polymer about** the single-die light-emitting diode.

110. The light-emission device of claim 100, comprising the luminophoric medium being in a **homogeneous** composition.

112. The light-emission device of claim 100, comprising the luminophoric medium being **on** polymer or glass.

Each of the above features was discussed above in conjunction with claims 63, 68-72, and 74 and applies here.

Proposed **new claims 114-116** read,

114. The light-emission device of claim 100, wherein the single-die light-emitting diode comprises gallium nitride and its alloys.

115. The light-emission device of claim 100, wherein the single-die light-emitting diode comprises at least one of gallium nitride, indium gallium nitride, aluminum gallium nitride, and aluminum gallium indium nitride.

116. The light-emission device of claim 100, comprising a light-emitting diode lamp.



Art Unit: 3992

Each of the above features was discussed above in conjunction with claims 76-79 and applies here.

Proposed new **claim 118** reads,

118. A light-emission device, comprising

a single-die, two-lead **gallium nitride based semiconductor blue light-emitting diode emitting radiation; and**

a recipient down-converting luminophoric medium for down-converting the radiation emitted by the light-emitting diode, to a polychromatic white light, wherein the luminophoric medium is **dispersed in a polymer that is on or about** the single-die, two-lead gallium nitride based semiconductor blue light-emitting diode.

Claim 118 is coextensive with claim 26, as indicated by Patentee (Remarks dated 3/26/2012, p. 45). Claim 118 differs from claim 26 in the same ways that claim 100 is distinguished from claim 26, except the *compatible characteristics* are as highlighted in bold. As noted above, Pinnow teaches these features and the combination remains obvious for the same reasons as indicated above.

Proposed new **claims 124-126 and 128** read,

124. The light-emission device of claim 118, comprising the single-die, two-lead gallium nitride based semiconductor blue light-emitting diode being arranged to **directly impinge** radiation on the polymer.

125. The light-emission device of claim 118, comprising the single-die, two-lead gallium nitride based semiconductor blue light-emitting diode and polymer being arranged **without intermediate material therebetween.**

126. The light-emission device of claim 118, comprising the luminophoric medium being in a **homogeneous** composition.

128. The light-emission device of claim 118, comprising the luminophoric medium being **on** polymer or glass.

Each of the above features was discussed above in conjunction with claims 63, 68-72, and 74 and applies here.

Proposed new **claims 130-132** read,

130. The light-emission device of claim 118, wherein the single-die light-emitting diode comprises gallium nitride and its alloys.

Art Unit: 3992

131. The light-emission device of claim 118, wherein the single-die light-emitting diode comprises at least one of gallium nitride, indium gallium nitride, aluminum gallium nitride, and aluminum gallium indium nitride.

132. The light-emission device of claim 118, comprising a light-emitting diode lamp.

Each of the above features was discussed above in conjunction with claims 76-79 and applies here.

Proposed new **claim 134** reads,

134. A light-emitting device, comprising:

at least one single-die **gallium nitride based** semiconductor **blue** light-emitting diode (LED) coupleable with a power supply to emit a primary radiation which is the same for each single-die LED present in the device, said primary radiation being a relatively shorter wavelength radiation; and

a down-converting luminophoric medium arranged in receiving relationship to said primary radiation, and which in exposure to said primary radiation, is excited to responsively emit a secondary, relatively longer wavelength, polychromatic radiation, with separate wavelengths of said polychromatic radiation mixing to produce a white light output,

wherein each of the at least one single-die gallium nitride based semiconductor blue light-emitting diode in interaction with luminophoric medium receiving its primary radiation produces white light output,

and wherein the luminophoric medium is **dispersed in a polymer that is on or about** the single-die gallium nitride based semiconductor blue light-emitting diode.

Each of the features of this claim has been discussed in conjunction with claims 5, 62, and 118, above and applies here.

Proposed new **claims 137 and 140-142** read,

137. The light-emitting device of claim 134, comprising the luminophoric medium **dispersed in a polymer that is about** the single-die gallium nitride based semiconductor blue light-emitting diode.

140. The light-emitting device of claim 134, comprising the single-die light-emitting diode being arranged to **directly impinge** radiation on the polymer.

Art Unit: 3992

141. The light-emitting device of claim 134, comprising the single-die light-emitting diode and polymer being arranged **without intermediate material therebetween**.

142. The light-emitting device of claim 134, comprising the luminophoric medium being in a **homogeneous** composition.

Each of the above features was discussed above in conjunction with claims 63, 68-72, and 74 and applies here.

Proposed new **claims 145-147** read,

145. The light-emitting device of claim 134, wherein the single-die light-emitting diode comprises gallium nitride and its alloys.

146. The light-emitting device of claim 134, wherein the single-die light-emitting diode comprises at least one of gallium nitride, indium gallium nitride, aluminum gallium nitride, and aluminum gallium indium nitride.

147. The light-emission device of claim 134, comprising a light-emitting diode lamp.

Each of the above features was discussed above in conjunction with claims 76-79 and applies here.

4. Claims 187 and 188 are rejected under 35 U.S.C. 103(a) as being unpatentable over Stevenson in view of Pinnow and Tadatsu.

Proposed new **claims 187 and 188** read,

187. A light emitting device comprising a light-emitting diode operative to emit **blue or ultraviolet** radiation, **packaged with luminophoric medium in a polymeric matrix**, wherein the luminophoric medium absorbs blue or ultraviolet radiation from the light-emitting diode and down converts same to a broad spectrum of frequencies producing polychromatic white light, wherein the light-emitting diode is a single-die, two-lead semiconductor light-emitting diode.

188. The light-emitting device of claim 187, wherein the light-emitting diode is operative to emit **blue** light.

Claims 187 and 188 are distinguished from claim 26 in (1) specifying the radiation emitted from the LED as being blue or UV and (2) the luminophoric medium being in a polymeric matrix. As discussed above, Stevenson's Fig. 4 shows that the GaN-based LED emits blue-to-UV light and therefore reads on these claims.

Art Unit: 3992

With regard to distinction (1), Stevenson discloses that the LED emits from blue to UV light as evidenced by Stevenson's Fig. 4, as was discussed above in the rejection over Stevenson.

With regard to distinction (2), also as noted above in the rejection over Stevenson in view of any of Pinnow, Menda, and APA, Pinnow teaches that the phosphors can be dispersed in an organic resin, which is a polymeric matrix:

In this description, use will be made of the term "colorant" or "organic colorant." It is to be understood that this term includes photoluminescent organic dyes and pigments. **Pigments** are particularly useful and may be formed by **dissolving a dye in an organic resin solution which is subsequently condensed**. It is known that luminescent efficiency in certain cases may be enhanced if the dye is absorbed on a colloid which may take the form of gell [sic] fibers or particles of high molecular weight polymers.

(Pinnow, paragraph bridging cols. 1-3; emphasis added)

The invention is broadly premised on the use of such organic colorants. Monochromatic displays result from use of **homogeneous phosphor screens**. These may be present as **self-supporting members** or as **coatings**, and they may be made up on **one or any combination of colorants required to produce the desired balance**.

(Pinnow, col. 2, lines 15-20; emphasis added)

Thus, Pinnow teaches that phosphors are packaged in a polymeric matrix.

In addition, Tadatsu discloses a packaged LED **11** wherein a primary radiation is down-converted by a luminophor **5** to a longer wavelength, and is therefore in the same field of endeavor as is Stevenson. Tadatsu also desires producing white light. In this regard, Tadatsu states,

[Constitution] A light emitting diode having a light emitting device on a stem, the light emitting device being surrounded with a **resin mold**, wherein said **light emitting device is made of gallium nitride related compound semiconductors** which are expressed with a general formula of  $Ga_xAl_{1-x}N$  (where  $0 \leq x \leq 1$ ), and further wherein a **fluorescent dye or pigment**, which is **excited with emission light from said gallium nitride related compound semiconductors** and which **emits fluorescent light**, is **added to said resin mold**.

(Tadatsu translation, p. 1)

Tadatsu's Fig. 2 (reproduced below) shows the packaged LED has two leads **2, 3** and a housing member ("resin mold" **4**) within which the luminophor ("fluorescent dye" **5**) is dispersed. Tadatsu also indicates that the luminophor can be organic or inorganic:

Art Unit: 3992

[0003] Ordinarily, a resin with a large index of refraction and a high transparency is selected for the resin mold 4, so that the emission light from the light emitting device is efficiently emitted to the air. In other cases, an **inorganic or organic pigment is mixed as a coloring agent in the resin mold 4** in order to convert or correct the emission color of the light emitting device. For instance, when a red pigment is added to a resin mold around a green light emitting device having GaP semiconductor materials, its **emission color turns into white.**

(Tadatsu translation ¶ [0003]; emphasis added)

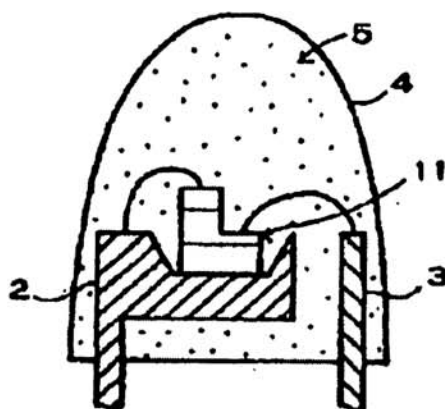

(Tadatsu, Fig. 2)

Thus Tadatsu discloses that the light-emitting diode **11** is *packaged with luminophoric medium in a polymeric matrix*, as required by claims 187 and 188.

It would have been obvious to one of ordinary skill in the art, at the time of the invention to put Stevenson/Pinnow's phosphor mixture in the resin housing member, and to package Stevenson's GaN-based blue LED as in Tadatsu because Stevenson is silent as to where the phosphors should be oriented relative to the LED, such that one of ordinary skill would use a known packaging method that achieves the correct relative orientation to allow the light emitted from the LED to interact with the luminophor, such as that orientation taught in Tadatsu.

In addition, it is noted that Tadatsu teaches that it is desired in the lighting arts to produce **white** light from a **single** LED by down-converting the LED's primary radiation using phosphors (i.e. dyes and pigments excited by the primary radiation from the LED) to produce a mixture of wavelengths that mix to produce white light (*id.*). So even if it is believed that Stevenson and Pinnow somehow fail to produce sufficient information to those of ordinary skill in the lighting arts to mix the phosphors of Pinnow --that are already mixed together to produce white light in black and white luminescent display screens-- then Tadatsu provides even more evidence that those of ordinary skill in the art desire white light from a **single LED**



Art Unit: 3992

by using phosphors, and would therefore ensure that Stevenson's mixture of phosphors produces white light.

5. Claims 63-65, 68, 70-73, 101-103, 106, 108-111, 119-121, 124, 126, 127, 135-137, 140, 142, 143, 187 and 188 are rejected under 35 U.S.C. 103(a) as being unpatentable over Stevenson in view of Pinnow and Nakamura as applied to claims 62, 100, 118, and 134, above, and further in view of Tadatsu.

The prior art of Stevenson in view of Pinnow and Nakamura, as explained above in the previous rejection, teaches each of the features of claims 62, 100, 118, and 134.

Proposed new **claims 63-65, 68, and 70-73** read,

63. The light-emitting device of claim 62, comprising the luminophoric medium being arranged **about** the single-die light-emitting diode.

64. The light-emitting device of claim 62, comprising the luminophoric medium being **contiguous to** the single-die light-emitting diode.

65. The light-emitting device of claim 64, comprising the single-die light-emitting diode comprising side die surface, and the luminophoric medium being **contiguous to the side die surface**.

68. The light-emitting device of claim 62, comprising the single-die light-emitting diode being arranged to **directly impinge** primary radiation on the luminophoric medium.

70. The light-emitting device of claim 62, comprising the luminophoric medium being **dispersed in** polymer or glass.

71. The light-emitting device of claim 70, comprising the luminophoric medium being **dispersed in polymer about** the single-die light-emitting diode.

72. The light-emitting device of claim 70, comprising the luminophoric medium being in a **homogeneous** composition.

73. The light-emitting device of claim 72, wherein the **homogeneous** composition is **contiguous to** the single die light-emitting diode.

As noted above in the previous rejection, Stevenson in view of Pinnow and Nakamura teaches the features of claim 62. The **homogenous mixture of phosphors dispersed in a polymer or resin** that produce white light in response to blue light primary radiation is taught by Pinnow, as discussed above.

Art Unit: 3992

None of Stevenson, Pinnow, and Nakamura teaches the luminophoric medium being *contiguous to*, or *contiguous to a side surface*, or of the LED.

As indicated above, Tadatsu discloses a packaged LED **11** wherein a primary radiation is down-converted by a luminophor **5** to a longer wavelength, and is therefore in the same field of endeavor as is Stevenson. Tadatsu also desires producing white light. In this regard, Tadatsu states,

[Constitution] A light emitting diode having a light emitting device on a stem, the light emitting device being surrounded with a **resin mold**, wherein said **light emitting device is made of gallium nitride related compound semiconductors** which are expressed with a general formula of  $Ga_xAl_{1-x}N$  (where  $0 \leq x \leq 1$ ), and further wherein a **fluorescent dye or pigment**, which is **excited with emission light from said gallium nitride related compound semiconductors** and which **emits fluorescent light**, is **added to said resin mold**.

(Tadatsu translation, p. 1)

Tadatsu's Fig. 2 (reproduced below) shows the packaged LED has two leads **2, 3** and a housing member ("resin mold" **4**) within which the luminophor ("fluorescent dye" **5**) is dispersed. Tadatsu also indicates that the luminophor can be organic or inorganic:

[0003] Ordinarily, a resin with a large index of refraction and a high transparency is selected for the resin mold **4**, so that the emission light from the light emitting device is efficiently emitted to the air. In other cases, an **inorganic or organic pigment is mixed as a coloring agent in the resin mold 4** in order to convert or correct the emission color of the light emitting device. For instance, when a red pigment is added to a resin mold around a green light emitting device having GaP semiconductor materials, its **emission color turns into white**.

(Tadatsu translation ¶ [0003]; emphasis added)

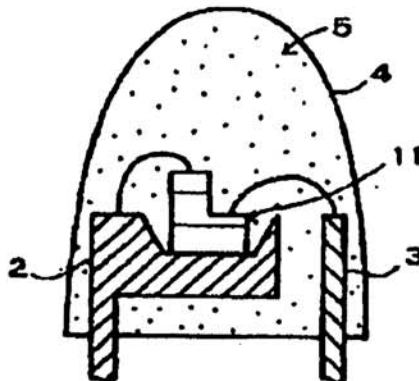

(Tadatsu, Fig. 2)

Art Unit: 3992

It would have been obvious to one of ordinary skill in the art, at the time of the invention to put Stevenson/Pinnow's phosphor mixture in the resin housing member, and to package Stevenson/Nakamura's GaN-based blue LED as in Tadatsu because Stevenson is silent as to where the phosphors should be oriented relative to the LED, such that one of ordinary skill would use a known packaging method that achieves the correct relative orientation to allow the light emitted from the LED to interact with the luminophor, such as that orientation taught in Tadatsu.

So packaged, Pinnow's phosphor mixture is *homgenously dispersed* in Tadatsu's polymer or resin mold **4** around Stevenson/Nakamura's GaN-based blue LED. The resulting device has a *luminophoric medium* (phosphor mixture) that is *about*, is *contiguous to the LED on all sides*, and is *directly impinged by the primary radiation* from the GaN-based blue LED, as required by claims 63-65, 68, and 70-73.

Proposed new **claims 101-103, 106, and 108-111** read,

101. The light-emission device of claim 100, comprising the luminophoric medium being arranged **about** the single-die light-emitting diode.

102. The light-emission device of claim 100, comprising the luminophoric medium being **contiguous to** the single-die light-emitting diode.

103. The light-emission device of claim 102, comprising the single-die light-emitting diode comprising side die surface, and the luminophoric medium being **contiguous to the side die surface**.

106. The light-emission device of claim 100, comprising the single-die light-emitting diode being arranged to **directly impinge** primary radiation on the luminophoric medium.

108. The light-emission device of claim 100, comprising the luminophoric medium being **dispersed in** polymer or glass.

109. The light-emission device of claim 108, comprising the luminophoric medium being **dispersed in polymer about** the single-die light-emitting diode.

110. The light-emission device of claim 100, comprising the luminophoric medium being in a **homogeneous** composition.

111. The light-emission device of claim 110, wherein the **homogeneous** composition is **contiguous to** the single-die light-emitting diode.

As noted above in the previous rejection, Stevenson in view of Pinnow and Nakamura teaches all of the features of claim 100. Each of the features of claims 101-103, 106, and 108-111 was discussed in conjunction with claims 63-65, 68, and 70-73 which applies here.

Art Unit: 3992

Proposed new **claims 119-121, 124, 126, and 127** read,

119. The light-emission device of claim 118, comprising the luminophoric medium **dispersed in a polymer that is on** the single-die, two-lead gallium nitride based semiconductor blue light-emitting diode.

120. The light-emission device of claim 119, comprising the single-die, two-lead gallium nitride based semiconductor blue light-emitting diode comprising die side surface, and wherein the **polymer is contiguous to the die side surface**.

121. The light-emission device of claim 118, comprising the luminophoric medium **dispersed in a polymer that is about** the single-die, two-lead gallium nitride based semiconductor blue light-emitting diode.

124. The light-emission device of claim 118, comprising the single-die, two-lead gallium nitride based semiconductor blue light-emitting diode being arranged to **directly impinge** radiation on the polymer.

126. The light-emission device of claim 118, comprising the luminophoric medium being in a **homogeneous** composition.

127. The light-emission device of claim 126, wherein the **homogeneous** composition is **contiguous to** the single-die light-emitting diode.

As noted above in the previous rejection, Stevenson in view of Pinnow and Nakamura teaches all of the features of claim 118. Each of the features of claims 119-121, 124, 126, and 127 was discussed in conjunction with claims 63-65, 68, and 70-73 which applies here.

Proposed new claims **135-137, 140, 142, and 143** read,

135. The light-emitting device of claim 134, comprising the luminophoric medium **dispersed in a polymer that is on** the single-die gallium nitride based semiconductor blue light-emitting diode.

136. The light-emitting device of claim 135, comprising the single-die gallium nitride based semiconductor blue light-emitting diode comprising die side surface, and wherein the **polymer is contiguous to the die side surface**.

137. The light-emitting device of claim 134, comprising the luminophoric medium **dispersed in a polymer that is about** the single-die gallium nitride based semiconductor blue light-emitting diode.

140. The light-emitting device of claim 134, comprising the single-die light-emitting diode being arranged to **directly impinge** radiation on the polymer.

Art Unit: 3992

142. The light-emitting device of claim 134, comprising the luminophoric medium being in a **homogeneous** composition.

143. The light-emitting device of claim 142, wherein the **homogeneous** composition is **contiguous to** the single-die light-emitting diode.

As noted above in the previous rejection, Stevenson in view of Pinnow and Nakamura teaches all of the features of claim 134. Each of the features of claims 135-137, 140, 142, and 143 was discussed in conjunction with claims 63-65, 68, and 70-73 which applies here.

Regarding **claims 187 and 188**, to the extent it is believed that claim 187 excludes violet light emission by reciting "blue or ultraviolet", then this may be a difference between claims 187 and 188, and Stevenson. Note, however, just as the commercially available GaN-based LED from Nichia used in the '175 patent (col. 9, lines 10-18) emits a significant amount of both UV and violet light, Patentee cannot argue that the LED emits **only** blue or UV light, as this would contradict the '175 patent and the inventor Bartz's Declaration dated 3/26/2012, paragraph 18, which shows the Nichia LED emits light from UV to blue, just as does Stevenson's.

Nakamura is applied as above, to show that it would be obvious to substitute Stevenson's GaN-based LED with Nakamura's GaN-based LED which emits blue light. Thus, Stevenson in view of Pinnow, Nakamura, and Tadatsu teaches each of the features of claims 187 and 188.

6. Claims 63, 66-72, 74, 101, 104-110, 112, 121-126, 128, 137-142, 162-166 and 168-171 are rejected under 35 U.S.C. 103(a) as being unpatentable over Stevenson in view of Pinnow and Nakamura as applied to claims 62, 100, 118, and 134, above, and further in view of Tabuchi.

The prior art of Stevenson in view of Pinnow and Nakamura, as explained above in the previous rejection, teaches each of the features of claims 62, 100, 118, and 134.

Proposed new claims 63, 66-72, and 74 read,

63. The light-emitting device of claim 62, comprising the luminophoric medium being arranged **about** the single-die light-emitting diode.

66. The light-emitting device of claim 62, comprising the single-die light-emitting diode comprising side die surface, and the luminophoric medium being in **laterally spaced relationship to said side die surface**.

67. The light-emitting device of claim 66, wherein the luminophoric medium is in **laterally spaced facing relationship to said side die surface**.



Art Unit: 3992

68. The light-emitting device of claim 62, comprising the single-die light-emitting diode being arranged to **directly impinge** primary radiation on the luminophoric medium.

69. The light-emitting device of claim 62, comprising the single-die light-emitting diode and luminophoric medium being arranged **without intermediate material** therebetween.

70. The light-emitting device of claim 62, comprising the luminophoric medium being **dispersed in** polymer or glass.

71. The light-emitting device of claim 70, comprising the luminophoric medium being **dispersed in polymer about** the single-die light-emitting diode.

72. The light-emitting device of claim 70, comprising the luminophoric medium being in a **homogeneous** composition.

74. The light-emitting device of claim 62, comprising the luminophoric medium being **on** polymer or glass.

As noted above in the previous rejection, Stevenson in view of Pinnow and Nakamura teaches the features of claim 62. The **homogenous mixture of phosphors dispersed in a polymer or resin** that produce white light in response to blue light primary radiation is taught by Pinnow:

In this description, use will be made of the term "colorant" or "organic colorant." It is to be understood that this term includes photoluminescent organic dyes and pigments. **Pigments** are particularly useful and may be formed by **dissolving a dye in an organic resin solution [i.e. a polymer] which is subsequently condensed**. It is known that luminescent efficiency in certain cases may be enhanced if the dye is **absorbed on a colloid** which may take the form of gell [sic] fibers or particles of high molecular weight **polymers**.

(Pinnow, paragraph bridging cols. 1-3; emphasis added)

The invention is broadly premised on the use of such organic colorants. Monochromatic displays result from use of **homogeneous phosphor screens**. These may be present as **self-supporting members** or as **coatings**, and they may be made up on **one or any combination of colorants required to produce the desired balance**.

(Pinnow, col. 2, lines 15-20; emphasis added)

Thus, the phosphors may be dispersed in a polymer whether the polymer is coated made into a coating or formed into a "self-supporting member".

Art Unit: 3992

None of Stevenson, Pinnow, and Nakamura teaches the luminophoric medium being *laterally spaced relationship to said side die surface* (claim 66), or *laterally spaced facing relationship to said side die surface* (claim 67).

Tabuchi's Fig. 1 (reproduced below) shows a LED **4** in a housing including transparent cover **6** having a phosphor film **7** coated thereon to convert the primary radiation (UV or IR) from said LED **4** into visible light. In this regard, Tabuchi states,

Figure 1 depicts a **light emitting semiconductor apparatus** of an example of the present utility model invention. In the example, the present utility model invention is applied to a light emitting semiconductor apparatus which employs a so-called TO-5 stem. Figure 1, glass 2 fixes leads 3 in a TO-5 metal stem 1. A **light emitting semiconductor device 4** is conductively connected to stem 1. A transparent cover 6 according to the present utility model invention is fixed on stem 1. **A phosphor layer 7** is provided by applying **a binding agent** in which a phosphor to convert the radiation from light emitting semiconductor device **4** to visible light **is dispersed on the inner surface of transparent cover 6**. **Transparent cover 6** is made of a material such as **glass** or **an epoxy resin** is preferably fixed to stem 1 so that it can also function as a cap for hermetic sealing.

In the light emitting apparatus of the present utility model invention, **phosphor layer 7 converts** infrared or **UV** emitted from **light emitting semiconductor device 4** to **visible light** which is radiated in random directions. Therefore, the light emitting semiconductor apparatus can produce an emission with a uniform intensity over a large area. Further, the light emitting semiconductor apparatus utilizes a relatively small quantity of phosphor and hence, is inexpensive.

(Tabuchi translation, pp. 3-4; emphasis added)

A light emitting semiconductor apparatus of the present utility model invention is not limited to the structures and materials illustrated in the above examples. For example, it goes without saying that a **near UV light emitting devices with GaN** can be employed and that **an ordinary UV-visible light conversion phosphor** can be utilized.

(Tabuchi translation, p. 5; emphasis added)

Art Unit: 3992

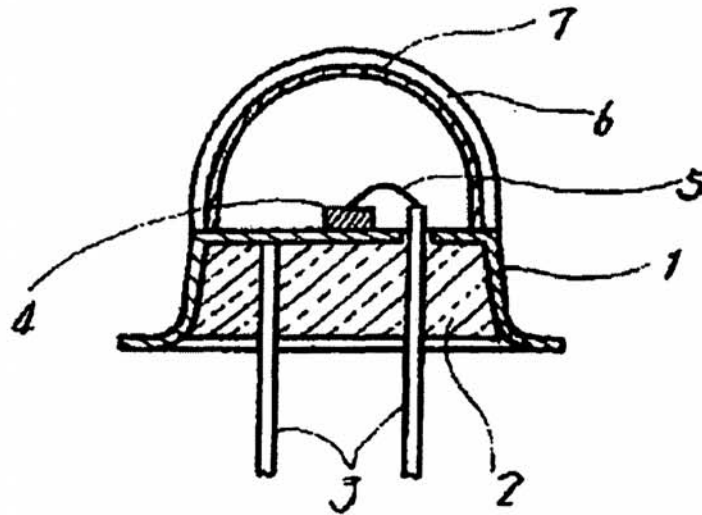

(Tabuchi, Fig. 1)

As shown in Tabuchi's Fig. 1 above, the phosphor is (1) *about* the LED (claim 63) *without intermediate material* between the phosphor 7 and the LED 4 (claim 69), (2) is *laterally spaced relationship* to said side die surface (claim 66), (3) is *laterally spaced facing relationship* to said side die surface (claim 67). It is also evident that the phosphor 7 is *directly impinged* by the primary radiation from the LED 4 (claim 68).

Because Tabuchi uses a binder to make the phosphor coating and because Pinnow teaches the phosphor mixture is homogeneously dispersed in a resin to make the phosphor coatings, Pinnow's phosphor mixtures oriented on the walls of Tabuchi's cover would result in the features of claims 70-72 and 74 above.

It would have been obvious to one of ordinary skill in the art, at the time of the invention to put Stevenson's or Stevenson/Pinnow's inorganic phosphors in a film on the surface of a housing member (Tabuchi), and to package Stevenson/Nakamura's GaN-based LED as in Tabuchi because Stevenson/Nakamura is silent as to where the phosphors should be oriented relative to the LED, such that one of ordinary skill would use a known packaging method that achieves the correct relative orientation to allow the light emitted from the LED to interact with the luminophor, such as that orientation taught in Tabuchi.

Thus, Stevenson/Pinnow/Nakamura's light-emitting device modified to locate Pinnow's mixture of phosphors as in Tabuchi renders obvious the features of claims 63, 66-72, and 74.

Proposed new **claims 101, 104-110, and 112** read,

101. The light-emission device of claim 100, comprising the luminophoric medium being arranged **about** the single-die light-emitting diode.

Art Unit: 3992

104. The light-emission device of claim 100, comprising the single-die light-emitting diode comprising side die surface, and the luminophoric medium being in **laterally spaced relationship to said side die surface.**

105. The light-emission device of claim 104, wherein the luminophoric medium is in **laterally spaced facing relationship to said side die surface.**

106. The light-emission device of claim 100, comprising the single-die light-emitting diode being arranged to **directly impinge** primary radiation on the luminophoric medium.

107. The light-emission device of claim 100, comprising the single-die light-emitting diode and luminophoric medium being arranged **without intermediate material therebetween.**

108. The light-emission device of claim 100, comprising the luminophoric medium being **dispersed in** polymer or glass.

109. The light-emission device of claim 108, comprising the luminophoric medium being **dispersed in polymer about** the single-die light-emitting diode.

110. The light-emission device of claim 100, comprising the luminophoric medium being in a **homogeneous** composition.

112. The light-emission device of claim 100, comprising the luminophoric medium being **on** polymer or glass.

As noted above in the previous rejection, Stevenson in view of Pinnow and Nakamura teaches all of the features of claim 100. Each of the features of claims 101, 104-110, and 112 was discussed in conjunction with claims 63, 66-72, and 74 which applies here.

Proposed new **claims 121-126 and 128** read,

121. The light-emission device of claim 118, comprising the luminophoric medium **dispersed in a polymer** that is **about** the single-die, two-lead gallium nitride based semiconductor blue light-emitting diode.

122. The light-emission device of claim 118, comprising the single-die, two-lead gallium nitride based semiconductor blue light-emitting diode comprising die side surface, and wherein the polymer is in **laterally spaced relationship to said side die surface.**

123. The light-emission device of claim 122, wherein the polymer is in **laterally spaced facing relationship to said side die surface.**

Art Unit: 3992

124. The light-emission device of claim 118, comprising the single-die, two-lead gallium nitride based semiconductor blue light-emitting diode being arranged to **directly impinge** radiation on the polymer.

125. The light-emission device of claim 118, comprising the single-die, two-lead gallium nitride based semiconductor blue light-emitting diode and polymer being arranged **without intermediate material therebetween**.

126. The light-emission device of claim 118, comprising the luminophoric medium being in a **homogeneous** composition.

128. The light-emission device of claim 118, comprising the luminophoric medium being **on** polymer or glass.

As noted above in the previous rejection, Stevenson in view of Pinnow and Nakamura teaches all of the features of claim 118. Each of the features of claims 121-126 and 128 was discussed in conjunction with claims 63, 66-72, and 74 which applies here.

Proposed new **claims 137-142** read,

137. The light-emitting device of claim 134, comprising the luminophoric medium **dispersed in a polymer** that is **about** the single-die gallium nitride based semiconductor blue light-emitting diode.

138. The light-emitting device of claim 134, comprising the single-die gallium nitride based semiconductor blue light-emitting diode comprising die side surface, and wherein the polymer is in **laterally spaced relationship to said side die surface**.

139. The light-emitting device of claim 138, wherein the polymer is in **laterally spaced facing relationship to said side die surface**.

140. The light-emitting device of claim 134, comprising the single-die light-emitting diode being arranged to **directly impinge** radiation on the polymer.

141. The light-emitting device of claim 134, comprising the single-die light-emitting diode and polymer being arranged **without intermediate material therebetween**.

142. The light-emitting device of claim 134, comprising the luminophoric medium being in a **homogeneous** composition.

As noted above in the previous rejection, Stevenson in view of Pinnow and Nakamura teaches all of the features of claim 134. Each of the features of claims 137-142 was discussed in conjunction with claims 63, 66-72, and 74 which applies here.



Art Unit: 3992

Proposed new **claim 162** reads,

162. A light-emitting device, comprising:

at least one single-die **gallium nitride based** semiconductor **blue** light-emitting diode (LED) coupleable with a power supply to emit a primary radiation which is the same for each single-die LED present in the device, said primary radiation being a relatively shorter wavelength blue light radiation; and

a down-converting luminophoric medium arranged in receiving relationship to said primary radiation, and which in exposure to said primary radiation, is excited to responsively emit a secondary, relatively longer wavelength, polychromatic radiation, with separate wavelengths of said polychromatic radiation mixing to produce a white light output,

wherein each single-die gallium nitride based semiconductor blue light-emitting diode in interaction with luminophoric medium receiving its primary radiation produces white light output,

and wherein said at least one single-die gallium nitride based semiconductor blue light-emitting diode is **in a housing comprising a light-transmissive wall member in spaced relationship** to said at least one single-die gallium nitride based semiconductor blue light-emitting diode,

and **wherein said luminophoric medium is dispersed in or on said light-transmissive wall member.**

Claim 162 is coextensive with claim 26, as indicated by Patentee (Remarks dated 3/26/2012, pp. 58-59). Claim 162 differs from claim 5 in requiring the LED be a GaN-based blue-light-emitting LED and the orientation of the luminophoric medium in or on a light-transmissive wall member.

As noted above in the rejection of claim 5 over Stevenson in view of Pinnow and Nakamura, the GaN-based LED is obvious. As noted above in this rejection of claims 63, 66-72, and 74, the light-transmissive wall member **6** having a phosphor coating **7** thereon in spaced relationship to the LED **4** is obvious over Tabuchi. Thus, all of the additional features of claim 162 are obvious for the reasons already discussed above.

Proposed new **claim 163** reads,

163. The light-emitting device of claim 162, wherein said luminophoric medium is **dispersed in said light-transmissive wall member.**

Art Unit: 3992

Although Tabuchi does not teach that the phosphor **7** can be *dispersed in* the wall member **6**, Pinnow teaches that a phosphor mixture dispersed in organic resin (i.e. polymer) can be used to make a self-supporting member. Again Pinnow states,

In this description, use will be made of the term "colorant" or "organic colorant." It is to be understood that this term includes photoluminescent organic dyes and pigments. **Pigments** are particularly useful and may be formed by **dissolving a dye in an organic resin solution [i.e. a polymer] which is subsequently condensed**. It is known that luminescent efficiency in certain cases may be enhanced if the dye is **absorbed on a colloid** which may take the form of gell [sic] fibers or particles of high molecular weight **polymers**.

(Pinnow, paragraph bridging cols. 1-3; emphasis added)

The invention is broadly premised on the use of such organic colorants. Monochromatic displays result from use of **homogeneous phosphor screens**. These may be present as **self-supporting members** or as **coatings**, and they may be made up on **one or any combination of colorants required to produce the desired balance**.

(Pinnow, col. 2, lines 15-20; emphasis added)

Thus, the phosphors may be dispersed in a polymer whether the polymer is coated made into a coating or formed into a "self-supporting member".

It would have been obvious to one of ordinary skill in the art, at the time of the invention to form Pinnow's phosphor mixture into a self-supporting member in the form of Tabuchi's wall member **6** because Pinnow teaches that the phosphor mixture functions for the same purpose whether it is in the form of a coating or a self-supporting member (*id.*). As such, Pinnow tells those of ordinary skill that it is a matter of design choice to form the phosphor mixture in resin as a self-supporting member or as a coating. Therefore, one of ordinary skill can see the Tabuchi's phosphor coating **7** on the wall member **6** can be consolidated into a self-supporting member having the phosphor dispersed therein.

This "design choice" is substantially rationale B: simple substitution of one known element for another (MPEP 2143). Pinnow proves the predictability because Pinnow teaches that both forms of the phosphor mixture in resin (coating or self-supporting member) function to down-convert blue or UV primary radiation into polychromatic secondary radiation that mixes to produce white light.

This is all of the features of claim 163.

Proposed new **claims 164-166** read,

164. The light-emitting device of claim 162, wherein said luminophoric medium is **dispersed on** said light-transmissive wall member.

Art Unit: 3992

165. The light-emitting device of claim 162, wherein the light-transmissive wall member comprises **polymer**.

166. The light-emitting device of claim 162, wherein the light-transmissive wall member comprises **glass**.

Again Tabuchi states that the housing member **6** onto which the phosphor **7** is dispersed can be made from glass or epoxy resin (i.e. polymer):

Transparent cover 6 is made of a material such as **glass** or an **epoxy resin**...  
(Tabuchi translation, pp. 3-4; emphasis added)

Proposed new **claims 168 and 169** read,

168. The light-emitting device of claim 162, wherein the single-die light-emitting diode comprises **gallium nitride and its alloys**.

169. The light-emitting device of claim 162, wherein the single-die light-emitting diode comprises at least one of **gallium nitride, indium gallium nitride, aluminum gallium nitride, and aluminum gallium indium nitride**.

Again, Nakamura teaches GaN-based LED and the use of Nakamura's GaN-based, blue-light-emitting LED in place of Stevenson's GaN-based blue-to-UV LED is obvious for the reasons indicated above in the rejection over Stevenson in view of Pinnow and Nakamura, which applies here.

Proposed new **claims 170 and 171** read,

170. The light-emitting device of claim 162, wherein the at least one single-die gallium nitride based semiconductor blue light-emitting diode comprises **only one** single-die gallium nitride based semiconductor blue light-emitting diode.

171. The light-emitting device of claim 162, comprising a light-emitting diode **lamp**.

Stevenson, Nakamura, and Tabuchi each teach only one single LED which renders claims 170 and 171 obvious.

7. Claims 5, 11-13, 21, 22, 26, 172, and 176 is rejected under 35 U.S.C. 103(a) as being unpatentable over Stevenson in view of Pinnow and Edmond.

The prior art of Stevenson, as explained above, is believed to disclose each of the features of claim 5, 12, 13, 21, 22, 26, 172, and 176.

Art Unit: 3992

Stevenson does not teach an LED made on a SiC substrate (claims 11 and 12) or from including specifically SiC LED structure layers (claim 12 and 13).

Edmond discloses LEDs made on a SiC substrate having a multilayered device structure, wherein the layers include SiC, said SiC-based LEDs have peak maximum at several ranges in the blue wavelength spectrum:

The present invention comprises a light emitting diode formed in silicon carbide and that emits **visible light** having a wavelength of between about **475-480 nanometers**, or between about **455-460 nanometers**, or between about **424-428 nanometers**. The diode comprises a **substrate of alpha silicon carbide** having a first conductivity type and a **first epitaxial layer of alpha silicon carbide** upon the substrate having the same conductivity type as the substrate. A **second epitaxial layer of alpha silicon carbide** is upon the first epitaxial layer, has the opposite conductivity type from the first layer, and **forms a p-n junction** with the first epitaxial layer.

(Edmond, abstract; emphasis added)

It would have been obvious to one of ordinary skill in the art, at the time of the invention to substitute Stevenson's GaN-based LED with the SiC-based LED disclosed in Edmond. This can be seen as simple substitution of one known element (Stevenson's GaN-based LED) for another known element (Edmond's SiC-based LED) to obtain predictable results (as evidenced by Pinnow) and is one of the rationales identified by the Supreme Court in *KSR International Co. v. Teleflex Inc.*, 550 U.S. \_\_\_, \_\_\_, 82 USPQ2d 1385, 1395-97 (2007). (See MPEP 2143, Rationale B.)

Both Stevenson's and Edmond's LEDs emit light in the same general region of the spectrum, so even though the materials from which the LED are made are different, it is the wavelength of light emitted that counts, and Pinnow teaches that the wavelength of light need only be shorter than 495 nm (4950 Å) to be effective to be converted by the mixture of phosphors to white light. Thus, in regard to the predictability, as already noted above, Pinnow teaches that any wavelength of primary radiation can be down-converted by the mixture of phosphors to produce white light so long as the wavelength is less than 4950 Å (495 nm):

Regardless of how many phosphors are used, it is apparent from the chromaticity diagram that a necessary condition for achieving a true white is that the illuminating laser beam have a **wavelength of approximately 4,950 A. or shorter**. Otherwise, it is impossible to include illuminant C within a polygon whose primaries are the source and any combination of longer wavelengths that can be achieved by down-conversion of frequency. Fortunately, the argon-ion laser satisfies this necessary condition.

(Pinnow, col. 3, lines 24-55; emphasis added)

(It is noted that Pinnow uses "A." for "angstrom", which is properly, instead, Å.)

Art Unit: 3992

Thus, Pinnow teaches those of ordinary skill that shifting the peak maximum of the LED in Stevenson slightly from 413 nm (violet) to any of the wavelengths of Edmond's SiC LED, e.g. 424-428 nm, would yield entirely predictable results of white light emission with the down-converting phosphor mixture. The predictability results from using LEDs that emit light having a wavelength of less than 4950 Å (495 nm), specifically blue light in the case of Edmond.

Stevenson modified by Edmond to use Edmond's SiC LEDs therefore teaches each of the features of claims 5, 11-13, 21, 22, and 26, as follows.

Regarding **claim 5**, there is no requirement that the light be outside the visible white light spectrum, but substituting Stevenson LED with those of Edmond would still read on claim 5 because the secondary radiation emitted by the phosphor mixture of Stevenson/Pinnow would be white light.

Proposed amended **claims 11 and 12 and claim 13** read,

*11. A light-emitting device according to claim 5, wherein each single-die semiconductor LED present in the device is on a substrate in a multilayer device structure, and wherein said substrate comprises **silicon carbide**.*

*12. A light-emitting device according to claim 5, wherein each single-die semiconductor LED present in the device is on a substrate in a multilayer device structure, and wherein said substrate comprises a material selected from the group consisting of sapphire, **SiC**, and InGaAIN.*

*13. A light-emitting device according to claim 12, wherein said multilayer device structure includes layers selected from the group consisting of **silicon carbide**, aluminum nitride, gallium nitride, gallium phosphide, germanium carbide, indium nitride, and their mixtures and alloys.*

As shown in Edmond's abstract, above, and Edmond's Figs. 1-8, the substrate is SiC and the device layers include SiC.

Further regarding proposed new **claims 172 and 176**, because Pinnow teaches plural phosphors making white light, the secondary, down-converted radiation of the Stevenson/Edmond/Pinnow light-emitting device has a *broad spectrum of frequencies*.

8. Claims 2 and 23 are rejected under 35 U.S.C. 103(a) as being unpatentable over any of (1) Stevenson in view of **Imamura**, (2) Stevenson in view of any of Pinnow, Menda, and APA, and further in view of **Imamura**, (3) Stevenson in view of Pinnow, Nakamura, and **Imamura**, and (4) Stevenson in view of Pinnow, Edmond and **Imamura**.



Art Unit: 3992

**Claims 2 and 23** read,

2. A light-emitting device according to claim 1, comprising a **two-lead array** of single-die semiconductor LEDs.
23. A light-emitting device according to claim 5, comprising a **two-lead array** of single-die semiconductor LEDs.

The prior art of any of (1) Stevenson, (2) Stevenson in view of any of Pinnow, Menda, and APA, (3) Stevenson in view of Pinnow and Nakamura, and (4) Stevenson in view of Pinnow and Edmond, as explained above, discloses each of the features of claim 1 and 5.

Stevenson does not explicitly disclose a two-lead **array** of single-die LEDs. However, Stevenson does disclose using an array of LED to produce a display (Stevenson, col. 4, lines 5-7).

Imamura's Figs. 4 and 5 (reproduced below) shows the top and side views of an light array **10** made from an array of single-die semiconductor LEDs **13** on a substrate **15** (Imamura, col. 3, lines 16-36).

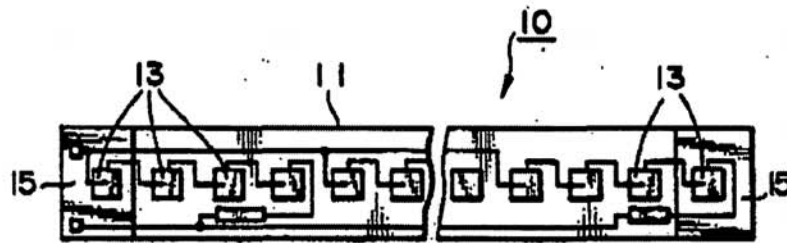

(Imamura, Fig. 4)

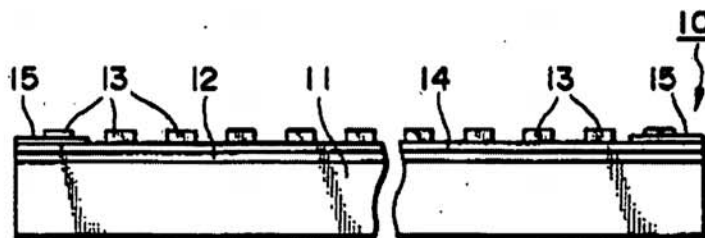

(Imamura, Fig. 5)

The array **10** can be used as a backlight for a liquid crystal display, such as shown in Fig. 8 (Imamura, col. 4, lines 59-61). Each LED die **13** has two leads that connect to the array's two leads, made from the gold-plated copper pattern **12** shown in the side view of right side of Fig. 5 and in the top view as the horizontal lines running across the top and bottom of the substrate **15** that connect the array

Art Unit: 3992

of LEDs **13**. As also shown in Fig. 4, each of the array's two leads ends in a terminal. Thus, Imamura teaches a **two-lead array of single-die semiconductor LEDs**.

It would have been obvious to one of ordinary skill in the art, at the time of the invention to use Imamura's two-lead array configuration of plural identical LEDs -- therefore *emitting identical radiation*-- for Stevenson's array of LED, because Stevenson is silent as to how an array of LED would be wired for a display, such that one of ordinary skill would follow known ways of assembling an array such as taught by Imamura (Imamura, col. 3, lines 37-60).

9. Claims 1, 5, 12, 13, 21, 22, 26-28, 30-33, 41, 42, 44-47, 55, 56, 58-61, 172, 173, 176-178, 187, and 188 are rejected under 35 U.S.C. 103(a) as being unpatentable over Stevenson in view of **Tadatsu** or, in the alternative, over Stevenson in view of APA and **Tadatsu**

Proposed new claims 28, 30, 42, 44, 56, and 58 read,

28. The light emitting device of claim 27, wherein the inorganic luminophor is dispersed **on or in** a housing member.

30. The light emitting device of claim 27, wherein the inorganic luminophor is **within** a housing member.

42. The light-emitting device of claim 41, wherein the inorganic luminophor is dispersed **on or in** a housing member.

44. The light-emitting device of claim 41, wherein the inorganic luminophor is **within** a housing member.

56. The light-emission device of claim 55, wherein the inorganic luminophor is dispersed **on or in** a housing member.

58. The light-emission device of claim 55, wherein the inorganic luminophor is **within** a housing member.

The prior art of Stevenson, or Stevenson in view of APA, as explained above, discloses each of the features of claims 1, 5, 12, 13, 21, 22, 26, 27, 31-33, 41, 45-47, 55, 59-61, 172, 176, and 178.

Stevenson does not indicate where the inorganic phosphors should be located and thus does not teach luminophors in or within a housing member.

Tadatsu discloses a package LED **11** wherein a primary radiation is down-converted by a luminophor **5** to a longer wavelength, and is therefore in the same field of

Art Unit: 3992

endeavor as is Stevenson. Tadatsu also desires producing white light. In this regard, Tadatsu states,

[Constitution] A light emitting diode having a light emitting device on a stem, the light emitting device being surrounded with a **resin mold**, wherein said **light emitting device is made of gallium nitride related compound semiconductors** which are expressed with a general formula of  $Ga_xAl_{1-x}N$  (where  $0 \leq x \leq 1$ ), and further wherein a **fluorescent dye or pigment**, which is **excited with emission light from said gallium nitride related compound semiconductors** and which **emits fluorescent light**, is **added to said resin mold**.

(Tadatsu translation, p. 1)

Tadatsu's Fig. 2 (reproduced below) shows the packaged LED have two leads **2, 3** and a housing member ("resin mold" **4**) within which the luminophor ("fluorescent dye" **5**) is dispersed. Tadatsu also indicates that the luminophor can be organic or inorganic:

[0003] Ordinarily, a resin with a large index of refraction and a high transparency is selected for the resin mold **4**, so that the emission light from the light emitting device is efficiently emitted to the air. In other cases, an **inorganic or organic pigment is mixed as a coloring agent in the resin mold 4** in order to convert or correct the emission color of the light emitting device. For instance, when a red pigment is added to a resin mold around a green light emitting device having GaP semiconductor materials, its **emission color turns into white**.

(Tadatsu translation ¶ [0003]; emphasis added)

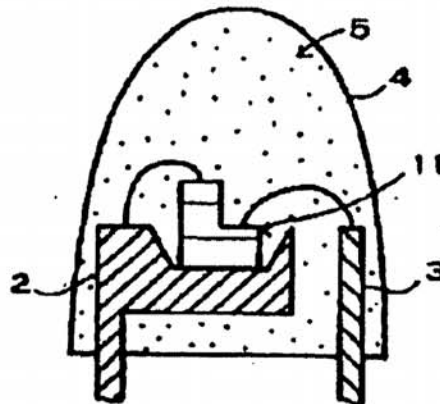

(Tadatsu, Fig. 2)

It would have been obvious to one of ordinary skill in the art, at the time of the invention to put Stevenson's or Stevenson/APA's inorganic phosphors in the resin housing member, and to package Stevenson's GaN-based LED as in Tadatsu

Art Unit: 3992

because Stevenson is silent as to where the phosphors should be oriented relative to the LED, such that one of ordinary skill would use a known packaging method that achieves the correct relative orientation to allow the light emitted from the LED to interact with the luminophor, such as that orientation taught in Tadatsu.

Proposed new **claims 173 and 177** read,

173. The light-emitting device of claim 5, wherein the single-die semiconductor light-emitting diode is on a support in an interior volume of a light-transmissive enclosure.

177. The light-emission device of claim 26, wherein the single-die, two-lead semiconductor light-emitting diode is on a support in an interior volume of a light-transmissive enclosure.

As noted above, it would be obvious to package Stevenson's two-lead LED as in Tadatsu; so packaged, the LED would be *on a support* (Tadatsu lead **2**) *in an interior volume of a light-transmissive enclosure* (Tadatsu, molded resin **4**).

Proposed new **claims 187 and 188** read,

187. A light emitting device comprising a light-emitting diode operative to emit **blue or ultraviolet** radiation, **packaged with luminophoric medium in a polymeric matrix**, wherein the luminophoric medium absorbs blue or ultraviolet radiation from the light-emitting diode and down converts same to a broad spectrum of frequencies producing polychromatic white light, wherein the light-emitting diode is a single-die, two-lead semiconductor light-emitting diode.

188. The light-emitting device of claim 187, wherein the light-emitting diode is operative to emit **blue** light.

As noted above, Tadatsu teaches dispersing the phosphor in the resin mold, thus Stevenson's LED packaged according to Tadatsu would include the phosphors in a polymeric matrix whether Stevenson's or APA's phosphors are used.

Claims 1, 5, 12, 13, 21, 22, 26, 27, 31-33, 41, 45-47, 55, 59-61, 172, 176, 178, 187, and 188 are rejected here, again, with the addition of Tadatsu, to provide even more reasons to mix the phosphors to produce white light. Tadatsu teaches that it is desired in the lighting arts to produce **white** light from a **single LED** by down-converting the LED's primary radiation using phosphors (i.e. dyes and pigments excited by the primary radiation from the LED) to produce a mixture of wavelengths that mix to produce white light (*id.*). So even if it is believed that Stevenson and APA somehow fail to produce sufficient information to those of ordinary skill in the lighting arts to mix the phosphors of APA --that are already mixed together to produce white light in fluorescent light bulbs and in EL cells-- then Tadatsu provides even more evidence that those of ordinary skill in the art

Art Unit: 3992

desire white light from a **single LED** by using phosphors, and would therefore ensure that Stevenson's mixture of phosphors produce white light.

10. Claims 28-30, 42-44, 56-58, 173, and 177 are rejected under 35 U.S.C. 103(a) as being unpatentable over Stevenson in view of **Tabuchi** or, in the alternative, over Stevenson in view of APA and **Tabuchi**.

Proposed new claims 28-30, 42-44, and 56-58 read,

28. The light emitting device of claim 27, wherein the inorganic luminophor is dispersed **on or in** a housing member.

29. The light emitting device of claim 27, wherein the inorganic luminophor is dispersed **in a film on a surface** of a housing member.

30. The light emitting device of claim 27, wherein the inorganic luminophor is **within** a housing member.

42. The light-emitting device of claim 41, wherein the inorganic luminophor is dispersed **on or in** a housing member.

43. The light emitting device of claim 41, wherein the inorganic luminophor is dispersed **in a film on a surface** of a housing member.

44. The light-emitting device of claim 41, wherein the inorganic luminophor is **within** a housing member.

56. The light-emission device of claim 55, wherein the inorganic luminophor is dispersed **on or in** a housing member.

57. The light emitting device of claim 55, wherein the inorganic luminophor is dispersed **in a film on a surface** of a housing member.

58. The light-emission device of claim 55, wherein the inorganic luminophor is **within** a housing member.

The prior art of Stevenson or, in the alternative, Stevenson in view of APA, as explained above, discloses each of the features of claims 1, 27, 5, 41, 26, and 55.

Stevenson does not indicate where the inorganic phosphors should be located and thus does not teach luminophors (1) *on or in a housing member*, (2) *in a film on a surface of a housing member*, or (3) *within a housing member*.

As noted above, APA teaches that it is notoriously well known in the lighting arts to place a mixture of inorganic phosphors in a coating on the surface of a housing member, e.g. a fluorescent light bulb, to produce white light:



Art Unit: 3992

It is well known that so-called **fluorescent lamps provide white light** illumination. In a fluorescent lamp, the Hg vapor in the vacuum tube is excited by an electrical discharge. The excited Hg atoms emit light, **primarily in the ultraviolet region** (e.g., 254 nm, 313 nm, 354 nm), which is absorbed by the **inorganic phosphors coating the inside walls of the tube**. The phosphors then emit light. These inorganic phosphors are designed as such to offer white light emission by "down-converting" (i.e., transforming a higher frequency, shorter wavelength form of energy to a lower frequency, longer wavelength form of energy) the ultraviolet emissions of the excited states of atomic Hg into a **broad spectrum** of emitted light which appears as **white** to the observer.

(the '175 patent, col. 3, lines 40-52; emphasis added)

Tabuchi's Fig. 1 (reproduced below) shows a LED **4** in a housing including transparent cover **6** having a phosphor film **7** coated thereon to convert the primary radiation (UV or IR) from said LED **4** into visible light. In this regard, Tabuchi states,

Figure 1 depicts a **light emitting semiconductor apparatus** of an example of the present utility model invention. In the example, the present utility model invention is applied to a light emitting semiconductor apparatus which employs a so-called TO-5 stem. Figure 1, glass 2 fixes leads 3 in a TO-5 metal stem 1. A **light emitting semiconductor device 4** is conductively connected to stem 1. A transparent cover 6 according to the present utility model invention is fixed on stem 1. **A phosphor layer 7 is provided by applying a binding agent in which a phosphor to convert the radiation from light emitting semiconductor device 4 to visible light is dispersed on the inner surface of transparent cover 6.** Transparent cover 6 is made of a material such as **glass** or an **epoxy** resin is preferably fixed to stem 1 so that it can also function as a cap for hermetic sealing.

In the light emitting apparatus of the present utility model invention, **phosphor layer 7 converts** infrared or **UV** emitted from **light emitting semiconductor device 4 to visible light** which is radiated in random directions. Therefore, the light emitting semiconductor apparatus can produce an emission with a uniform intensity over a large area. Further, the light emitting semiconductor apparatus utilizes a relatively small quantity of phosphor and hence, is inexpensive.

(Tabuchi translation, pp. 3-4; emphasis added)

A light emitting semiconductor apparatus of the present utility model invention is not limited to the structures and materials illustrated in the above examples. For example, it goes without saying that a **near UV light emitting devices with GaN** can be employed and that **an ordinary UV-visible light conversion phosphor** can be utilized.

(Tabuchi translation, p. 5; emphasis added)

Art Unit: 3992

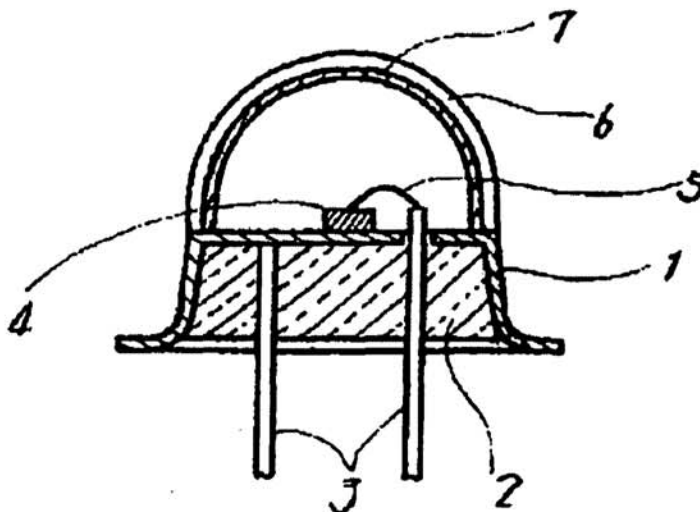

(Tabuchi, Fig. 1)

It would have been obvious to one of ordinary skill in the art, at the time of the invention to put Stevenson's or Stevenson/APA's inorganic phosphors in a film on the surface of a housing member (Tabuchi), and to package Stevenson's GaN-based LED as in Tabuchi because Stevenson is silent as to where the phosphors should be oriented relative to the LED, such that one of ordinary skill would use a known packaging method that achieves the correct relative orientation to allow the light emitted from the LED to interact with the luminophor, such as that orientation taught in Tabuchi.

Thus, Stevenson/APA modified to locate APA's mixture of phosphors as in Tabuchi teaches the phosphor mixture located (1) **on or in a housing member**, (2) **in a film on a surface of a housing member**, or (3) **within a housing member**.

Proposed new **claims 173 and 177** reads,

173. The light-emitting device of claim 5, wherein the single-die semiconductor light-emitting diode is on a support in an interior volume of a light-transmissive enclosure.

177. The light-emission device of claim 26, wherein the single-die, two-lead semiconductor light-emitting diode is on a support in an interior volume of a light-transmissive enclosure.

As noted above, it would be obvious to package Stevenson's two-lead LED as in Tabuchi, so packaged, the LED would be *is on a support* (Tabuchi "stem" **1**) *in an interior volume of a light-transmissive enclosure* (Tabuchi, "transparent cover" **6**).

Art Unit: 3992

11. Claims 3, 34, 38-40 are rejected under 35 U.S.C. 103(a) as being unpatentable over Stevenson in view of APA and Nakamura.

Claim 3 reads,

3. A light-emitting device, comprising:

a semiconductor **laser** coupleable with a power supply to emit a primary radiation having a relatively shorter wavelength outside the **visible** light spectrum; and

a down-converting luminophoric medium arranged in receiving relationship to said primary radiation, and which in exposure to said primary radiation responsively emits polychromatic radiation in the visible light spectrum, with different wavelengths of said polychromatic radiation mixing to produce a white light output.

Claim 3 is distinguished from claim 1 in that (1) a *semiconductor laser* is required versus a *single-die semiconductor LED*; (2) the primary radiation is required to be outside the **visible** light spectrum, as opposed to outside the visible **white** light spectrum; and (3) the wording associated with the luminophoric medium.

With regard to **differences (1) and (2)**, Stevenson does not teach a semiconductor laser that produces primary radiation outside the visible spectrum. Stevenson does, however, teach a GaN-based LED producing blue-to-UV light and therefore produces light (i.e. the UV light) outside the visible light spectrum (Stevenson, Fig. 4).

As discussed above, in the rejection over Stevenson in view of Pinnow and Nakamura, the substitution of any of Nakamura's LEDs or LDs for Stevenson's LED is obvious. Again, Nakamura teaches GaN-based LEDs and lasers that emit both blue and UV light. (In fact, one LED indicated as suitable in the '175 invention is a GaN LED from Nichia Chemicals, to which Nakamura is assigned. See the '175 patent, col. 9, lines 10-18. Thus, Patentee admits to using known GaN-based LED for the instant invention.)

First, Nakamura indicates that GaN-based LED emitting light *outside the visible white light spectrum* are known in the art:

**Jpn. Pat. Appln. KOKAI Publication No. 4-68579** discloses a double-heterostructure having a p-type **GaInN** clad layer formed on an oxygen-doped, n-type **GaInN** light-emitting layer. ... The emission wavelength of the light-emitting device having this double-heterostructure is **365 to 406 nm**.

(Nakamura, col. 2, lines 7-14; emphasis added)

UV light is light less than 400 nm as evidenced by the CRC Handbook, *supra*.

Art Unit: 3992

In regard to its LEDs and lasers, Nakamura states the following:

The semiconductor device of the present invention includes a **light-emitting diode (LED)** and a **laser diode (LD)**.

(Nakamura, col. 4, lines 9-11)

It is still another object of the present invention to provide an **ultraviolet to red light-emitting device** having a wavelength in the region of **365 to 620 nm**.

(Nakamura, col. 2, lines 30-33; emphasis added)

FIG. 12 shows a structure of a **laser diode 40** having a double-heterostructure of the present invention.

The **laser diode 40** has a double-heterostructure constituted by an impurity-doped **In<sub>x</sub>Ga<sub>1-x</sub>N active layer 18** described above in detail in association with the light-emitting diode, and two clad layers sandwiching the active layer **18**, i.e., an n-type gallium nitride-based compound semiconductor layer **16** and a p-type gallium nitride-based compound semiconductor layer **20**, as described above. A buffer layer **14** described above in detail is formed on a substrate **12** described above in detail. An n-type gallium nitride layer **42** is formed on the buffer layer **14**, providing a contact layer for an n-electrode described below.

(Nakamura, col. 11, line 61 to col. 12, line 6; emphasis added)

Nakamura shows that the wavelength of the LED or LD can be controlled by controlling the dopant:

In the light-emitting device of the present invention, when the value of  $x$  in  $\text{In}_x\text{Ga}_{1-x}\text{N}$  of the light-emitting layer is close to 0, the device emits **ultraviolet** light. When the value of  $x$  increases, the emission falls in the longer-wavelength region. When the value of  $x$  is close to 1, the device emits red light. When the value of  $x$  is in the range of  $0 < x < 0.5$ , the light-emitting device of the present invention emits **blue** to yellow light in the wavelength range of **450** to 550 nm.

(Nakamura, col. 4, lines 52-59; emphasis added)

Nakamura provides numerous examples of LEDs emitting blue light (Examples 1-28 at cols. 13-20) including an emission **peak** value at, *inter alia*, 400 nm (Nakamura, col. 14, lines 64-65) at 405 nm (*id.*, claim 18, line 67), 430 nm (*id.*, col. 14, lines 51-52), and 480 nm (*id.*, col. 13, lines 40-42).

The peak emission wavelength at 400 nm and 405 nm show that the LEDs of these examples emit primarily **ultraviolet** light, as evidenced by the CRC Handbook. Similarly, those LEDs having peak emission at 430 nm and 480 nm emit primarily **blue** light.

Art Unit: 3992

It would have been obvious to one of ordinary skill in the art, at the time of the invention to substitute Stevenson's GaN-based LED with the UV light emitting LED GaN-based laser diodes disclosed in Nakamura. This can be seen as simple substitution of one known element (Stevenson's GaN-based LED) for another known element (Nakamura's GaN-based laser diode) to obtain predictable results and is one of the rationales identified by the Supreme Court in *KSR International Co. v. Teleflex Inc.*, 550 U.S. \_\_\_, \_\_\_, 82 USPQ2d 1385, 1395-97 (2007). (See MPEP 2143, Rationale B.)

The results are predictable because both Stevenson's and Nakamura's LED and LD emit light in the same general region of the spectrum and are GaN-based, so the LED and LD materials are essentially the same. As will be discussed below, because the phosphor mixture disclosed in APA emit white light in response to UV radiation and Nakamura's LDs emit light in the UV wavelength range, the results of using Nakamura's LD in Stevenson's device and APA's phosphor mixtures yield predictable results, i.e. the production of white light.

With regard to **difference (3)**, the luminophoric mixture: As noted above, in the rejection over Stevenson in view of any of Pinnow, Menda, and APA, it is obvious to use APA's inorganic or organic phosphor mixtures as Stevenson's inorganic or organic phosphor mixtures to produce white light using Stevenson's GaN-based LED. To repeat, the '175 patent is replete with admitted prior art indicating that it was well known to mix together phosphors, one for each of the primary colors, to produce white light output. For example, the '175 patent states,

It is well known that so-called **fluorescent lamps provide white light** illumination. In a fluorescent lamp, the Hg vapor in the vacuum tube is excited by an electrical discharge. The excited Hg atoms emit light, **primarily in the ultraviolet region** (e.g., 254 nm, 313 nm, 354 nm), which is absorbed by the **inorganic phosphors coating the inside walls of the tube**. The phosphors then emit light. These inorganic phosphors are designed as such to offer white light emission by "down-converting" (i.e., transforming a higher frequency, shorter wavelength form of energy to a lower frequency, longer wavelength form of energy) the ultraviolet emissions of the excited states of atomic Hg into a **broad spectrum** of emitted light which appears as **white** to the observer. **However, these light emitting devices are not solid-state, ...**

(the '175 patent, col. 3, lines 40-53; emphasis added)

Thus, the '175 teaches that the missing part is **not** the mixed phosphors but is, instead, the solid-state light emitting devices, e.g. LEDs. **But** Stevenson --20 years earlier-- already did this. Stevenson exchanged the UV light from electrically-excited Hg vapor with a **solid-state** GaN-based LED and used phosphors --just as in a fluorescent bulb-- to down-convert the blue-to-UV light to any other color and white light (Stevenson, paragraph bridging cols. 3-4, excerpt above).



Art Unit: 3992

The '175 patent discusses other known mixed, inorganic phosphor systems that produce white light and then acknowledges the following:

While the devices in the above examples vary in concept and construction, they demonstrate the utilization of **red, green and blue fluorescent materials**, all **inorganic** in composition, which when excited by **photons** or electron beams, can release multiple wavelengths of **secondary light emission** (luminescence of either fluorescent or phosphorescent character) to exhibit **white light** to the observer. This is generally true, even if microscopic domains of discrete colored light emission can be observed on the Lambertian surface of the light emitting device.

(the '175 patent, col. 4, lines 32-41; emphasis added)

The '175 patent admits that it is known in the art to mix phosphors together to produce white light from a **single** source of light. Again, all that is lacking is the LED, but Stevenson teaches this as well as explicitly stating to use organic or inorganic phosphors to produce visible light. Thus the only thing purported to be inventive in the '175 patent, the LED, was known 20 years before the '175 patent. Everything else, i.e. the phosphors is old and notoriously well known.

Another example of single white-light-emitting device discussed in the '175 patent's APA is the "thin film organic electroluminescent cell":

**White light emission** from thin film organic electroluminescent cells based on poly(vinylcarbazole PVK) thin films on ITO-coated glass has also been recently reported. ... It is well known that the excited carbazole moiety within the polymer aggregates in the excited state leads to **blue excimer emission**, in the absence of quenchers or dopants. In the example of the organic Mg:Ag:Alq:TAZ:doped PVK:ITO:Glass electroluminescent device, the quenchers of excimeric emission, are the **dopants blue emitting** 1,1,4,4-tetraphenylbuta-1,3-diene (TPB), **green emitting** 7-diethylamino-3-(2'benzothiazoyl)coumarin (Coumarin-6), and **red emitting** dicyanomethylene-2-methyl-6-p-dimethylaminostyryl-4H-pyran (DCM-1).

(the '175 patent, col. 5, lines 21-44; emphasis added)

Thus, the primary "blue excimer emission" is converted into each of the primary color by dopants that are **mixed** together to produce white light by the same cell.

The '175 patent also acknowledges that others have produced white light using LEDs by mixing wavelengths of light from **three separate** LEDs, each one producing a different "primary" color:

Given the **desirability of white light displays** (e.g., commercial bank "time and temperature" message boards, stadium scoreboards), **considerable effort has been expended to produce white light LEDs**. Although the recent availability of the blue LED makes a full color, and by extension a white light display realizable, conventionally it has been considered that such a display would require multiple LEDs. The **multiple** LEDs would be then

Art Unit: 3992

incorporated into complicated and expensive LED modules to obtain the required broad band illumination necessary to provide white light. Even if a discrete LED lamp were constructed that provides white illumination (as opposed to the utilization of a **multitude of single die, single color discrete LED lamps in a module or sub-assembly**), the current state of the art requires the utilization of multiple LED dies and typically at least four electrical leads to power these dies. U.S. Pat. No. 4,992,704 issued to Stinson teaches a variable color light emitting diode having a unitary housing of clear molded solid epoxy supporting **three LED dies characterized as producing color hues of red, green and blue**, respectively. There have been some recent introductions of commercial "full-color" LED lamps, that are essentially **discrete lamps** which afford a means of producing white light. All currently available examples of such lamps contain a minimum of three LED dies (or chips)--**one red, one green and one blue**, encapsulated in a single epoxy package.

(the '175 patent, col. 2, lines 25-50; emphasis added)

What the '175 patent does **not**, however, acknowledge is that Stevenson --**20 years before** the '175 patent-- already produced colored or white light by down-converting blue-to-UV light from the **same** GaN-based LED (rather than three separate LEDs, one emitting each primary color) by using organic or inorganic phosphors (Stevenson, paragraph bridging cols. 3-4; excerpt above).

All that Stevenson **may** not disclose is whether or not the phosphors are mixed together to produce white light. Given the APA discussed above, one would be hard-pressed to believe that it would escape the mind of the routineer in the lighting arts to mix the phosphors together to produce white light. Nonetheless, even if it is not implicit in Stevenson alone to mix the phosphors to produce white light, given the ample evidence in the '175 patent's APA for the desire to produce white light from a **single** light-emitting device by mixing phosphors together, (e.g. fluorescent bulbs, EL devices, *supra*), it would have been entirely obvious to one of ordinary skill at the time of the invention to mix together the phosphors in Stevenson to produce white light output from each single GaN-based LED because the '175 patent's APA admits that this is both highly desired and notoriously well known. In addition, one **benefit** would be to produce white light from a **single** LED rather than from **multiple** LEDs, thereby making the cost of white light less expensive, as clearly indicated by the APA.

Proposed new **claims 34 and 38-40** read,

34. The light-emitting device of claim 3, wherein the luminophoric medium comprises an **inorganic** luminophor.

38. The light-emitting device of claim 34, wherein the semiconductor laser comprises material selected from the group consisting of **gallium nitride and its alloys**.

Art Unit: 3992

39. The light-emitting device of claim 34, wherein the semiconductor laser comprises **gallium nitride**.

40. The light-emitting device of claim 34, wherein the semiconductor laser comprises **gallium nitride alloy**.

As noted above, APA discloses a mixture of inorganic phosphors (*luminophoric medium*) and the use of APA's phosphor mixture as Stevenson's phosphor is obvious for the reasons indicated above.

Nakamura discloses each of the features of claims 38-40. Therefore, Stevenson modified to use Nakamura's UV laser, includes GaN and/or its alloys.

12. Claims 62, 75, 100, and 113 are rejected under 35 U.S.C. 103(a) as being unpatentable over Stevenson in view of APA, Wanmaker, and Nakamura.

Proposed new **claim 62** reads,

62. A light-emitting device, comprising:

at least one single-die **gallium nitride based semiconductor blue light-emitting diode (LED)** coupleable with a power supply to emit a primary radiation which is the same for each single-die LED present in the device, said primary radiation being a relatively shorter wavelength blue light radiation; and

a down-converting luminophoric medium arranged in receiving relationship to said primary radiation, and which in exposure to said primary radiation, is excited to responsively emit a secondary, relatively longer wavelength, polychromatic radiation, with separate wavelengths of said polychromatic radiation mixing to produce a white light output, wherein each of the at least one single-die gallium nitride based semiconductor blue light-emitting diode in interaction with luminophoric medium receiving its primary radiation produces white light output,

and wherein the light-emitting device comprises one or more compatible characteristics selected from the group consisting of:

(i) the luminophoric medium being arranged **about** the single-die light-emitting diode;

(ii) the luminophoric medium being **contiguous to** the single-die light-emitting diode;

Art Unit: 3992

(iii) the single-die light-emitting diode comprising side surface and the luminophoric medium being in **laterally spaced relationship to said side surface**;

(iv) the luminophoric medium being dispersed **in polymer or glass**; and

(v) the luminophoric medium being **on polymer or glass**.

Claim 62 is coextensive with claim 5, as indicated by Patentee (Remarks dated 3/26/2012, pp. 28-29). Claim 62 is distinguished from claim 5 in (1) the LED is required to be a blue-light-emitting GaN-based LED, and (2) the one or more *compatible characteristics*. The substitution of Stevenson's blue-to-UV-light-emitting GaN-based LED with Nakamura's blue-light-emitting GaN-based LEDs is obvious for the reasons discussed above. The luminophoric medium (phosphor mixture of APA) is necessarily *about* the LED; otherwise, it would not interact with the primary radiation.

Proposed new **claim 75** reads,

75. The light-emitting device of claim 62, wherein the luminophoric medium comprises **inorganic** luminophoric material.

Recall that Stevenson discloses that organic or inorganic phosphors can be used to make each of the primary colors from the blue-to-UV light emitting GaN-based LED:

Thus, it is seen that there has been provided an improved **light emitting diode** capable of emitting light in the violet **region** of the spectrum. This device may be used as a source of violet light for applications where this spectral range is appropriate. This **light may be converted to lower frequencies (lower energy)** with good conversion efficiency using **organic and inorganic phosphors**. Such a conversion is appropriate not only to develop different colors for aesthetic purposes, but also to produce light in a spectral range of greater sensitivity for the human eye. By use of **different phosphors, all the primary colors may be developed from this same basic device**. An **array** of such devices may be used for **color display systems; for example, a solid state TV screen**.

(Stevenson, paragraph bridging cols. 3-4; emphasis added)

Again, as noted above in the rejection over Stevenson as evidenced by the CRC Handbook, Stevenson's Fig. 4 shows that there is significant emission in the blue wavelength range of the spectrum by the GaN-based LED that can be used in conjunction with **inorganic** phosphors to produce each of the primary colors. Thus, one of ordinary skill has a reasonable expectation of success in substituting Stevenson's GaN-based LED with Nakamura's blue-light-emitting LED, even when **inorganic** phosphors are used.



Art Unit: 3992

In addition, as noted above, APA teaches that it is known in the art to use inorganic phosphor mixtures coated on a glass housing to convert primary radiation from electrically excited Hg (mercury) vapor, as in fluorescent bulbs:

It is well known that so-called **fluorescent lamps provide white light** illumination. In a fluorescent lamp, the Hg vapor in the vacuum tube is excited by an electrical discharge. The excited **Hg atoms emit light, primarily in the ultraviolet region** (e.g., 254 nm, 313 nm, 354 nm), which is absorbed by the **inorganic phosphors coating the inside walls of the tube**. The phosphors then emit light. These inorganic phosphors are designed as such to offer white light emission by "down-converting" (i.e., transforming a higher frequency, shorter wavelength form of energy to a lower frequency, longer wavelength form of energy) the **ultraviolet** emissions of the excited states of atomic Hg into a **broad spectrum** of emitted light which appears as **white** to the observer. **However, these light emitting devices are not solid-state, ...**

(the '175 patent, col. 3, lines 40-53; emphasis added)

The '175 patent is not entirely accurate as to the emission of Hg vapor that is converted to visible light. Rather, the '175 patent fails to acknowledge that, in fact, such high intensity **blue** light is emitted by the Hg vapor that the phosphor coatings include inorganic compounds that absorb and convert, not just the UV wavelengths, but also the **blue** wavelengths to longer wavelength visible light, so that the blue does not overwhelm the emitted light. In this regard, Wanmaker states,

To obtain a satisfactory rendition of the colours of articles irradiated by a fluorescent lamp it is necessary to **suppress the intensity of the blue mercury lines emitted by the mercury vapour discharge** at wave lengths of **405 and 436 nm**.

To what extent this suppression is to be effected is dependent on the desired quality of the colour rendition and on the desired colour temperature of the lamp. An **attenuation of the said blue mercury lines** can be obtained if the wall of the lamp is provided with a layer which includes a light yellow coloured **red luminescing material which absorbs at least a part of the blue mercury radiation**. The **emitted radiation of this luminescent material provides a desired contribution in the red part of the spectrum** of the radiation emitted by the lamp. This known step is described in United Kingdom patent specification 737,828. **Magnesium arsenate** activated by **quadrivalent manganese** is used in practice as a **blue absorbing red luminescing material**. Furthermore the lamp includes a second luminescent layer which is provided on the absorption layer and which comprises **one or more luminescent materials** with which it is possible to achieve the desired spectral distribution of the radiation emitted by the lamp.

(Wanmaker, col. 1, lines 18-22; emphasis added)

Wanmaker goes on to improve upon the prior art phosphors with other phosphors that also convert the mercury blue lines to longer wavelength visible light.



Art Unit: 3992

Wanmaker is important here because it shows that those of ordinary skill in the art knew in 1974 --20 years before the '175 patent-- how to choose **inorganic** phosphor mixtures that down-convert **blue** light to visible white light --such as that produced by Nakamura's GaN-based LEDs emitting light in the **blue** region of the spectrum. Thus, Wanmaker provides evidence of success and predictable results in using APA's or Wanmaker's mixture of **inorganic** phosphors along with Nakamura's GaN-based, blue-light emitting LED in place of Stevenson's GaN-based LED.

This is all of the features of claim 75.

Proposed new **claim 100** reads,

100. A light-emission device, comprising

a single-die, two-lead **gallium nitride based** semiconductor **blue** light-emitting diode emitting radiation; and

a recipient down-converting luminophoric medium for down-converting the radiation emitted by the light-emitting diode, to a polychromatic white light, wherein the light-emission device comprises one or more compatible characteristics selected from the group consisting of:

(i) the luminophoric medium being arranged **about** the single-die light-emitting diode;

(ii) the luminophoric medium being **contiguous to** the single-die light-emitting diode;

(iii) the single-die light-emitting diode comprising side surface and the luminophoric medium being in **laterally spaced relationship to said side surface**;

(iv) the luminophoric medium being dispersed **in polymer or glass**; and

(v) the luminophoric medium being **on polymer or glass**.

Claim 100 is coextensive with claim 26, as indicated by Patentee (Remarks dated 3/26/2012, pp. 40-41). Claim 100 differs from claim 26 in the same ways that claim 62 is distinguished from claim 5. Therefore claim 100 is obvious for the same additional reasons as indicated above in conjunction with claim 62.

Proposed new **claim 113** reads,

113. The light-emitting device of claim 100, wherein the luminophoric medium comprises **inorganic** luminophoric material.

See discussion above directed to claim 75 which applies here.

Art Unit: 3992

13. Claims 3, 34, 35, 37-40, and 179 are rejected under 35 U.S.C. 103(a) as being unpatentable over Stevenson in view of APA and Nakamura and further in view of Tadatsu.

Proposed new claims 35, 37, and 179 read,

35. The light-emitting device of claim 34, wherein the inorganic luminophor is dispersed **on or in** a housing member.

37. The light-emitting device of claim 34, wherein the inorganic luminophor is **within** a housing member.

179. The light-emitting device of claim 3, wherein the luminophoric medium is **contiguous to** said semiconductor laser.

The prior art of Stevenson in view of APA and Nakamura, as explained above, discloses each of the features of claims 3, 34, and 38-40.

Stevenson does not indicate where the inorganic phosphors should be located and thus does not teach luminophoric medium on, in, or within a housing member, or is contiguous to the LED or laser diode.

Tadatsu discloses a package LED **11** wherein a primary radiation is down-converted by a luminophor **5** to a longer wavelength, and is therefore in the same field of endeavor as is Stevenson. Tadatsu also desires producing **white light**. In this regard, Tadatsu states,

[Constitution] A light emitting diode having a light emitting device on a stem, the light emitting device being surrounded with a **resin mold**, wherein said **light emitting device is made of gallium nitride related compound semiconductors** which are expressed with a general formula of  $Ga_xAl_{1-x}N$  (where  $0 \leq x \leq 1$ ), and further wherein a **fluorescent dye or pigment**, which is **excited with emission light from said gallium nitride related compound semiconductors** and which **emits fluorescent light**, is **added to said resin mold**.

(Tadatsu translation, p. 1)

Tadatsu's Fig. 2 (reproduced below) shows the packaged LED have two leads **2, 3** and a housing member ("resin mold" **4**) within which the luminophor ("fluorescent dye" **5**) is dispersed. Tadatsu also indicates that the luminophor can be organic or inorganic:

[0003] Ordinarily, a resin with a large index of refraction and a high transparency is selected for the resin mold 4, so that the emission light from the light emitting device is efficiently emitted to the air. In other cases, an **inorganic or organic pigment is mixed as a coloring agent in the resin**

Art Unit: 3992

**mold 4** in order to convert or correct the emission color of the light emitting device. For instance, when a red pigment is added to a resin mold around a green light emitting device having GaP semiconductor materials, its **emission color turns into white**.

(Tadatsu translation ¶ [0003]; emphasis added)

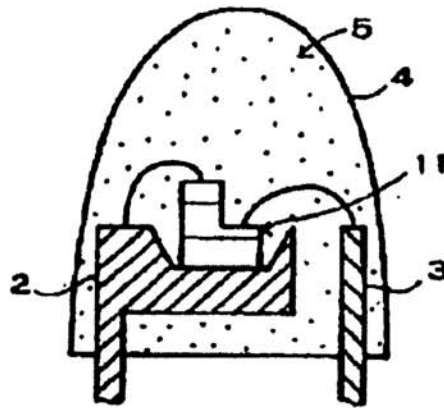

(Tadatsu, Fig. 2)

It would have been obvious to one of ordinary skill in the art, at the time of the invention to put Stevenson's or Stevenson/APA's inorganic phosphors in the resin housing member, and to package Stevenson/Nakamura's GaN-based laser as in Tadatsu because Stevenson/Nakamura is silent as to where the phosphors should be oriented relative to the LD, such that one of ordinary skill would use a known packaging method that achieves the correct relative orientation to allow the light emitted from the LD to interact with the luminophor, such as that orientation taught in Tadatsu. So oriented, the luminophoric medium is in and within a housing member, and is contiguous to Stevenson/Nakamura's laser, as taught by Tadatsu.

Claims 3, 34, and 38-40 are rejected here, again, with the addition of Tadatsu, to provide even more reasons to mix the phosphors. Tadatsu teaches that it is desired in the lighting arts to produce **white** light from a **single** LED by down-converting the LED's primary radiation using phosphors (i.e. dyes and pigments excited by the primary radiation from the LED) to produce a mixture of wavelengths that mix to produce white light (*id.*). So even if it is believed that Stevenson and APA somehow fail to produce sufficient information to those of ordinary skill in the lighting arts to mix the phosphors of APA --that are already mixed together to produce white light-- then Tadatsu provides even more evidence that those of ordinary skill in the art desire white light from a **single** LED.

Art Unit: 3992

14. Claims 35-37 are rejected under 35 U.S.C. 103(a) as being unpatentable over Stevenson in view of APA and Nakamura and further in view of Tabuchi.

Proposed new claim 36 reads,

35. The light-emitting device of claim 34, wherein the inorganic luminophor is dispersed **on or in** a housing member.

36. The light-emitting device of claim 34, wherein the inorganic luminophor is dispersed **in a film on a surface** of a housing member.

37. The light-emitting device of claim 34, wherein the inorganic luminophor is **within** a housing member.

The prior art of Stevenson in view of APA and Nakamura, as explained above, discloses each of the features of claims 3 and 34.

Tabuchi is applied as above in the rejection over Stevenson in view of APA and Tabuchi to show that it would have been obvious to those of ordinary skill in the art, at the time of the invention, to package the laser diode of Stevenson/Nakamura as in Tabuchi and thereby to have APA's mixture of phosphors located (1) **on or in** a housing member, (2) **in a film on a surface** of a housing member, or (3) **within** a housing member.

15. Claims 79, 80, 116-118, 129, 132-134, 144, 147, 148, 162, and 167 are rejected under 35 U.S.C. 103(a) as being unpatentable over Stevenson in view of APA, Wanmaker, and Nakamura and further in view of Tabuchi and Martic.

Proposed new **claims 118 and 129** read,

118. A light-emission device, comprising

a single-die, two-lead **gallium nitride based semiconductor blue** light-emitting diode emitting radiation; and

a recipient down-converting luminophoric medium for down-converting the radiation emitted by the light-emitting diode, to a polychromatic white light, wherein the luminophoric medium is **dispersed in a polymer that is on or about** the single-die, two-lead gallium nitride based semiconductor blue light-emitting diode.

129. The light-emission device of claim 118, wherein the luminophoric medium comprises **inorganic** luminophoric material.

Claim 118 is coextensive with claim 26, as indicated by Patentee (Remarks dated 3/26/2012, p. 45). The **GaN-based blue LED** and the luminophoric medium made