

(12) **United States Patent**
Baretz et al.

(10) **Patent No.:** **US 6,600,175 B1**
(45) **Date of Patent:** ***Jul. 29, 2003**

(54) **SOLID STATE WHITE LIGHT EMITTER AND DISPLAY USING SAME**

JP 5-152609 * 6/1993 257/98

(75) Inventors: **Bruce Baretz**, West Milford, NJ (US);
Michael A. Tischler, Danbury, CT (US)

(73) Assignee: **Advanced Technology Materials, Inc.**,
Danbury, CT (US)

(*) Notice: This patent issued on a continued prosecution application filed under 37 CFR 1.53(d), and is subject to the twenty year patent term provisions of 35 U.S.C. 154(a)(2).

Subject to any disclaimer, the term of this patent is extended or adjusted under 35 U.S.C. 154(b) by 1212 days.

(21) Appl. No.: **08/621,937**

(22) Filed: **Mar. 26, 1996**

(51) **Int. Cl.**⁷ **H01L 33/00**

(52) **U.S. Cl.** **257/100; 257/88; 257/98; 257/99**

(58) **Field of Search** **257/88, 98, 99, 257/100**

(56) **References Cited**

U.S. PATENT DOCUMENTS

3,593,055	A	*	7/1971	Geusic	257/98
3,763,405	A	*	10/1973	Mitsuhata	257/98
3,932,881	A	*	1/1976	Mita	257/98
4,992,704	A		2/1991	Stinson	315/312
5,126,214	A	*	6/1992	Tokailin	257/99
5,208,462	A	*	5/1993	O'Conner	257/98
5,405,709	A		4/1995	Littman et al.	428/690
5,583,349	A	*	12/1996	Norman	257/88
5,660,461	A	*	8/1997	Ignatius	257/88

FOREIGN PATENT DOCUMENTS

JP	60170194	9/1985
JP	04289691	10/1992

OTHER PUBLICATIONS

Sato, Y. et al, "Full-Color Fluorescent Display Devices Using a Near-UV Light Emitting Diode", *Jpn. J. Appl. Phys.* vol. 35 (1996) pp. L 838-L839.

J.I. Pankove and E.R. Levin, "Scanning Electron Microscopy Studies of GaN" *J. Appl. Phys.* vol. 46, (1975), pp. 1647-1652.

I. Akasaki, et al., "Photoluminescence of Mg-doped p-type GaN and Electroluminescence of GaN p-n Junction LED" *J. Lumin.*, vol. 48-49, (1991) pp. 666-670.

H. Amano et al., UV and Blue Electroluminescence from Al.GaN:Mg/GaN LED treated with Low-Energy Electron Beam Irradiation (LEEBI), *Inst. Phys. Conf. Ser.* vol. 106, (1990), pp. 725-730.

Munch et al, "Silicon Carbide Light-Emitting Diodes with Epitaxial Junctions" *Solid State Electronics*, vol. 19, (1976) p. 871.

Zhang Jin Chao et al., White Light Emitting Glasses, *Journal of Solid State Chemistry*, 93, 17-29 (1991), pp. 17-29.

(List continued on next page.)

Primary Examiner—Jerome Jackson

(74) *Attorney, Agent, or Firm*—Steven J. Hultquist; Margaret Chappuis

(57) **ABSTRACT**

A light emitting assembly comprising a solid state device coupleable with a power supply constructed and arranged to power the solid state device to emit from the solid state device a first, relatively shorter wavelength radiation, and a down-converting luminophoric medium arranged in receiving relationship to said first, relatively shorter wavelength radiation, and which in exposure to said first, relatively shorter wavelength radiation, is excited to responsively emit second, relatively longer wavelength radiation. In a specific embodiment, monochromatic blue or UV light output from a light-emitting diode is down-converted to white light by packaging the diode with fluorescent organic and/or inorganic fluorescers and phosphors in a polymeric matrix.

26 Claims, 3 Drawing Sheets

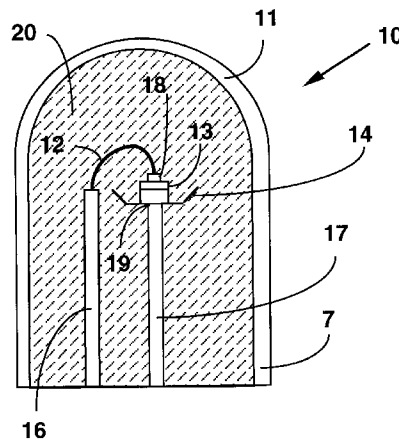

OTHER PUBLICATIONS

Shosaku Tanaka, et al., Bright White-Light Electroluminescence Based on Nonradiative Energy Transfer in Ce- and Eu-doped SrS Thin Films, *Appl. Phys. Lett.* 51 (21), Nov. 23, 1987, pp. 1661-1663.

M. Berggren et al., White Light From an Electroluminescent Diode Made From poly[3(4-octylphenyl)-2,2'-bithiophene] and an Oxadiazole Derivatives, *J. Appl. Phys.* 76 (11), Dec. 1, 1994, pp. 7530-7534.

J. Kido et al., White Light-Emitting Organic Electroluminescent Devices Using the poly(N-vinylcarbazole) Emitter Layer Doped with Three Fluorescent Dyes, *Appl. Phys. Lett.*, 64 (7) Feb. 14, 1994, pp. 815-817.

N. El Jouhar et al., White Light Generation Using Fluorescent Glasses Activated by Ce³⁺, Tb³⁺ and Mn²⁺ Ions, *J. De Physique IV, Colloque C2, supplement au j. de Physique III*, vol. 2, Oct. 1992, pp. 257-260.

* cited by examiner

FIGURE 1

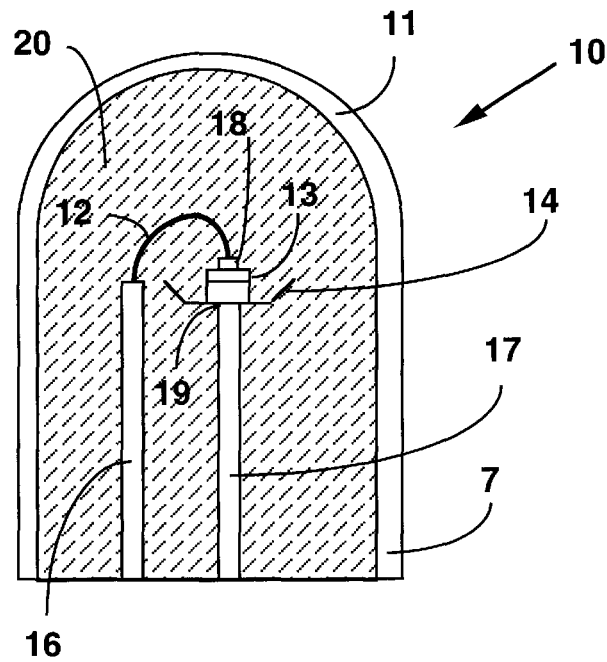

FIGURE 2

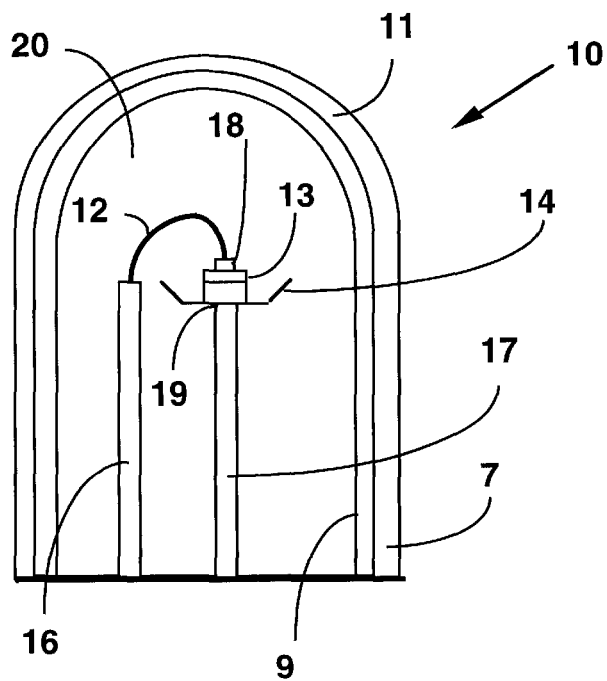

FIGURE 3

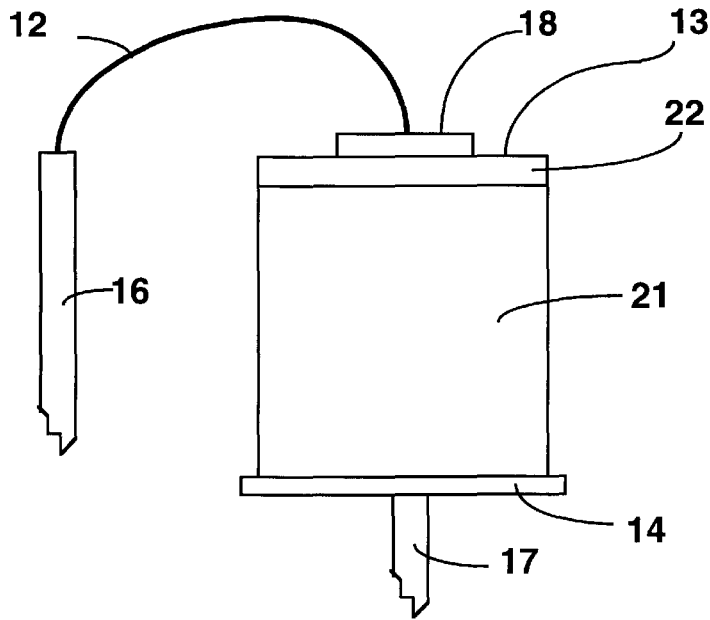

FIGURE 4

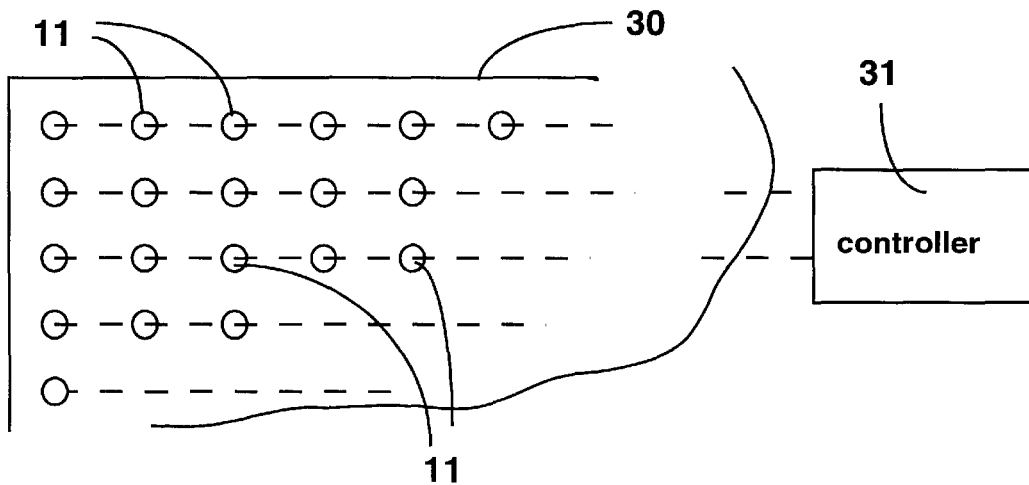

FIGURE 5

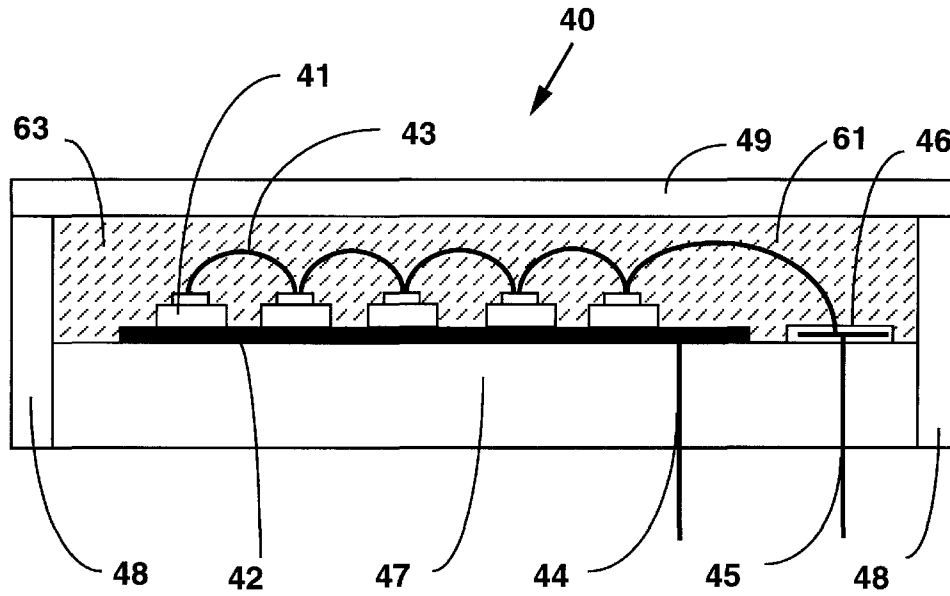
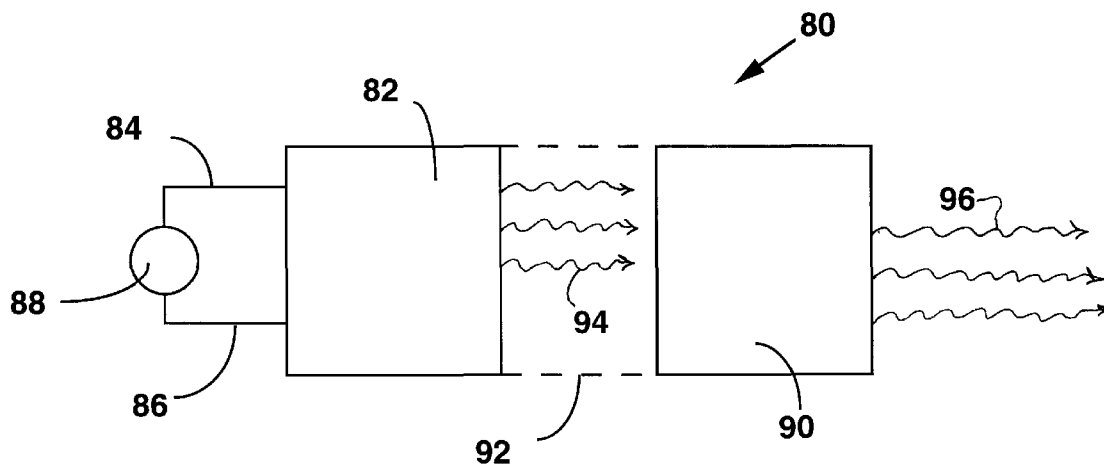

FIGURE 6



Explore Litigation Insights

Docket Alarm provides insights to develop a more informed litigation strategy and the peace of mind of knowing you're on top of things.

Real-Time Litigation Alerts



Keep your litigation team up-to-date with **real-time alerts** and advanced team management tools built for the enterprise, all while greatly reducing PACER spend.

Our comprehensive service means we can handle Federal, State, and Administrative courts across the country.

Advanced Docket Research



With over 230 million records, Docket Alarm's cloud-native docket research platform finds what other services can't. Coverage includes Federal, State, plus PTAB, TTAB, ITC and NLRB decisions, all in one place.

Identify arguments that have been successful in the past with full text, pinpoint searching. Link to case law cited within any court document via Fastcase.

Analytics At Your Fingertips



Learn what happened the last time a particular judge, opposing counsel or company faced cases similar to yours.

Advanced out-of-the-box PTAB and TTAB analytics are always at your fingertips.

API

Docket Alarm offers a powerful API (application programming interface) to developers that want to integrate case filings into their apps.

LAW FIRMS

Build custom dashboards for your attorneys and clients with live data direct from the court.

Automate many repetitive legal tasks like conflict checks, document management, and marketing.

FINANCIAL INSTITUTIONS

Litigation and bankruptcy checks for companies and debtors.

E-DISCOVERY AND LEGAL VENDORS

Sync your system to PACER to automate legal marketing.