

FORM PTO-1449 INFORMATION DISCLOSURE CITATION IN AN APPLICATION		DOCKET NUMBER MPW 3M1B		APPLICATION NUMBER			
		APPLICANTS ALBERT L. ARENDT, JAMES R. CARDUCCI and CHRISTOPHER F. LUCAS					
		FILING DATE May 9, 2011		GROUP ART UNIT			
U.S. PATENT DOCUMENTS							
EXAMINER INITIAL	DOCUMENT NUMBER	DATE	NAME	CLASS	SUB CLASS	FIL. DATE IF APPROP.	
	2008/0006456	1/10/2008	Lucas et al.				
	2005/0056474	3/17/2005	Damon				
	2004/0070262	4/15/2004	Markling				
	2003/0085611	5/8/2003	Markling				
	6,953,333	10/11/2005	Feuerherm et al.				
	6,913,324	7/5/2005	Markling				
	6,896,335	5/24/2005	Markling				
	6,872,354	3/29/2005	Mol et al.				
	6,591,986	7/15/2003	Soehnen et al.				
	6,520,597	2/18/2003	Markling				
FOREIGN PATENT DOCUMENTS							
	DOCUMENT NUMBER	DATE	COUNTRY	CLASS	SUB CLASS	TRANSLATION YES NO	
	WO 2008/008173 A2	01/17/2008	WIPO			X	
	WO 2008/008173 A3	01/17/2008	WIPO			X	
	DE 10125824A1	12/5/2002	Germany				X
	JP 2002-192607	7/10/2002	Japan				X
OTHER DOCUMENTS							
	English-language abstract of German Patent No. DE 10125824A1, 2002.						
	English-language abstract of Japanese Patent Publication No. JP 2002-192607, 2002.						
EXAMINER			DATE CONSIDERED				

Dynacraft BSC, Inc.
Exhibit 1015
Dynacraft v. Mattel
IPR2018-00042

FORM PTO-1449			DOCKET NUMBER		APPLICATION NUMBER	
INFORMATION DISCLOSURE CITATION IN AN APPLICATION			MPW 3M1B			
			APPLICANTS ALBERT L. ARENDT, JAMES R. CARDUCCI and CHRISTOPHER F. LUCAS			
			FILING DATE May 9, 2011		GROUP ART UNIT	
U.S. PATENT DOCUMENTS						
EXAMINER INITIAL	DOCUMENT NUMBER	DATE	NAME	CLASS	SUB CLASS	FIL. DATE IF APPROP.
	6,470,982	10/29/2002	Sitarski et al.			
	6,464,305	10/15/2002	Markling			
	6,446,981	9/10/2002	Wise et al.			
	7,621,543	11/24/2009	Arendt et al.			
	6,431,406	8/13/2002	Pruett			
	6,318,983	11/20/2001	Lopez et al.			
	6,170,920	1/9/2001	Markling			
	6,095,543	8/1/2000	McMahon et al.			
	6,068,161	5/30/2000	Soehnlén et al.			
	5,924,506	7/20/1999	Perego			
	5,908,124	6/1/1999	Klauke et al.			
	5,879,484	3/9/1999	Spragg et al.			
FOREIGN PATENT DOCUMENTS						
	DOCUMENT NUMBER	DATE	COUNTRY	CLASS	SUB CLASS	TRANSLATION YES NO
	JP 5-124095	5/21/1993	Japan			X
	JP 4-65219	3/2/1992	Japan			X
OTHER DOCUMENTS						
		English-language abstract of Japanese Patent No. JP 5-124095, 1993.				
		English-language abstract of Japanese Patent No. JP 4-65219, 1992.				
EXAMINER				DATE CONSIDERED		

FORM PTO-1449		DOCKET NUMBER		APPLICATION NUMBER		
INFORMATION DISCLOSURE CITATION IN AN APPLICATION		MPW 3M1B				
		APPLICANTS ALBERT L. ARENDT, JAMES R. CARDUCCI and CHRISTOPHER F. LUCAS				
		FILING DATE May 9, 2011		GROUP ART UNIT		
U.S. PATENT DOCUMENTS						
EXAMINER INITIAL	DOCUMENT NUMBER	DATE	NAME	CLASS	SUB CLASS	FIL. DATE IF APPROP.
	5,810,452	9/22/1998	Hawthorne et al.			
	5,799,809	9/1/1998	Sako et al.			
	5,750,067	5/12/1998	Hellbrugge			
	5,736,168	4/7/1998	Goyal et al.			
	5,573,129	11/12/1996	Nagata et al.			
	5,556,601	9/17/1996	Huvey et al.			
	5,518,682	5/21/1996	Markling et al.			
	5,368,371	11/29/1994	Markling			
	5,316,377	5/31/1994	Markling et al.			
	5,316,135	5/31/1994	Kneer et al.			
	5,227,114	7/13/1993	Moore			
	5,219,594	6/15/1993	Meyer et al.			
FOREIGN PATENT DOCUMENTS						
	DOCUMENT NUMBER	DATE	COUNTRY	CLASS	SUB CLASS	TRANSLATION YES NO
	JP 1-034721	2/6/1989	Japan			X
OTHER DOCUMENTS						
		English-language abstract of Japanese Patent No. JP 1-034721, 1989.				
		International Search Report for International Application No. PCT/US07/17676.				
		Written Opinion of the International Searching Authority for International Application No. PCT/US07/17676.				
EXAMINER			DATE CONSIDERED			

FORM PTO-1449		DOCKET NUMBER		APPLICATION NUMBER		
INFORMATION DISCLOSURE CITATION IN AN APPLICATION		MPW 3M1B				
		APPLICANTS ALBERT L. ARENDT, JAMES R. CARDUCCI and CHRISTOPHER F. LUCAS				
		FILING DATE May 9, 2011		GROUP ART UNIT		
U.S. PATENT DOCUMENTS						
EXAMINER INITIAL	DOCUMENT NUMBER	DATE	NAME	CLASS	SUB CLASS	FIL. DATE IF APPROP.
	D327,048	6/16/1992	Markling et al.			
	5,104,198	4/14/1992	Prout et al.			
	4,889,480	12/26/1989	Nakamura et al.			
	4,884,961	12/5/1989	Iizuka et al.			
	4,854,849	8/8/1989	Sudo			
	4,832,307	5/23/1989	Watanabe et al.			
	4,717,113	1/5/1988	Martin			
	4,588,542	5/13/1986	Pierce			
	4,531,704	7/30/1985	Matthei			
	4,516,648	5/14/1985	Berger et al.			
	4,513,981	4/30/1985	DeGraaff et al.			
	4,323,411	4/6/1982	Uhlig			
FOREIGN PATENT DOCUMENTS						
	DOCUMENT NUMBER	DATE	COUNTRY	CLASS	SUB CLASS	TRANSLATION YES NO
OTHER DOCUMENTS						
EXAMINER			DATE CONSIDERED			

FORM PTO-1449		DOCKET NUMBER		APPLICATION NUMBER			
INFORMATION DISCLOSURE CITATION IN AN APPLICATION		MPW 3M1B					
		APPLICANTS ALBERT L. ARENDT, JAMES R. CARDUCCI and CHRISTOPHER F. LUCAS					
		FILING DATE May 9, 2011		GROUP ART UNIT			
U.S. PATENT DOCUMENTS							
EXAMINER INITIAL	DOCUMENT NUMBER	DATE	NAME	CLASS	SUB CLASS	FIL. DATE IF APPROP.	
	4,063,868	12/20/1977	Piotrowski				
	3,936,264	2/3/1976	Cornett III et al.				
	3,907,370	9/23/1975	Bard				
	3,888,545	6/10/1975	Braun				
	3,851,029	11/26/1974	Cornett III et al.				
	3,817,676	6/18/1974	Seefluth				
	3,779,688	12/18/1973	Jullien-Davin				
	3,730,658	5/1/1973	Marra				
	3,692,453	9/19/1972	Quigg				
	3,616,491	11/2/1971	Vollers				
	3,592,885	7/13/1971	Goins et al.				
	3,570,057	3/16/1971	Doyle				
FOREIGN PATENT DOCUMENTS							
	DOCUMENT NUMBER	DATE	COUNTRY	CLASS	SUB CLASS	TRANSLATION YES NO	
OTHER DOCUMENTS							
EXAMINER				DATE CONSIDERED			

FORM PTO-1449		DOCKET NUMBER		APPLICATION NUMBER			
INFORMATION DISCLOSURE CITATION IN AN APPLICATION		MPW 3M1B					
		APPLICANTS ALBERT L. ARENDT, JAMES R. CARDUCCI and CHRISTOPHER F. LUCAS					
		FILING DATE May 9, 2011		GROUP ART UNIT			
U.S. PATENT DOCUMENTS							
EXAMINER INITIAL	DOCUMENT NUMBER	DATE	NAME	CLASS	SUB CLASS	FIL. DATE IF APPROP.	
	3,373,460	3/19/1968	Ladney, Jr.				
	3,264,780	8/9/1966	Doe				
	3,135,997	6/9/1964	Smyser				
	3,264,780	8/9/1966	Doe				
	3,029,468	4/17/1972	Valyi				
	2,601,700	7/1/1952	Pinsky et al.				
FOREIGN PATENT DOCUMENTS							
	DOCUMENT NUMBER	DATE	COUNTRY	CLASS	SUB CLASS	TRANSLATION YES NO	
OTHER DOCUMENTS							
EXAMINER				DATE CONSIDERED			

Electronic Patent Application Fee Transmittal

Application Number:	
Filing Date:	
Title of Invention:	BLOW-MOLDED WHEELS HAVING UNDERCUT TREADS, METHODS FOR PRODUCING THE SAME, AND CHILDREN'S RIDE-ON VEHICLES INCLUDING THE SAME
First Named Inventor/Applicant Name:	Albert L. Arendt
Filer:	Ian David Gates./Robin Davin
Attorney Docket Number:	MPW 3M1B

Filed as Large Entity

Utility under 35 USC 111(a) Filing Fees

Description	Fee Code	Quantity	Amount	Sub-Total in USD(\$)
Basic Filing:				
Utility application filing	1011	1	330	330
Utility Search Fee	1111	1	540	540
Utility Examination Fee	1311	1	220	220

Pages:

Claims:

Miscellaneous-Filing:

Petition:

Patent-Appeals-and-Interference:

Description	Fee Code	Quantity	Amount	Sub-Total in USD(\$)
Post-Allowance-and-Post-Issuance:				
Extension-of-Time:				
Miscellaneous:				
Total in USD (\$)				1090

Electronic Acknowledgement Receipt

EFS ID:	10046543
Application Number:	13103310
International Application Number:	
Confirmation Number:	9050
Title of Invention:	BLOW-MOLDED WHEELS HAVING UNDERCUT TREADS, METHODS FOR PRODUCING THE SAME, AND CHILDREN'S RIDE-ON VEHICLES INCLUDING THE SAME
First Named Inventor/Applicant Name:	Albert L. Arendt
Customer Number:	78569
Filer:	Ian David Gates./Robin Davin
Filer Authorized By:	Ian David Gates.
Attorney Docket Number:	MPW 3M1B
Receipt Date:	09-MAY-2011
Filing Date:	
Time Stamp:	14:10:27
Application Type:	Utility under 35 USC 111(a)

Payment information:

Submitted with Payment	yes
Payment Type	Deposit Account
Payment was successfully received in RAM	\$ 1090
RAM confirmation Number	515
Deposit Account	504551
Authorized User	

The Director of the USPTO is hereby authorized to charge indicated fees and credit any overpayment as follows:

Charge any Additional Fees required under 37 C.F.R. Section 1.16 (National application filing, search, and examination fees)

Charge any Additional Fees required under 37 C.F.R. Section 1.21 (Miscellaneous fees and charges)

File Listing:					
Document Number	Document Description	File Name	File Size(Bytes)/ Message Digest	Multi Part /.zip	Pages (if appl.)
1	Application Data Sheet	Application_Data_Sheet_MPW3M1B_5-9-11.pdf	113233 868580b6f3e2321206079013e9d0317f012d4c58c	no	4
Warnings:					
Information:					
This is not an USPTO supplied ADS fillable form					
2		continuation_patent_application_MPW3M1B_5-9-11.pdf	290377 bf1340a1ca12d919330d136bd30947f95bfc4e9e	yes	49
	Multipart Description/PDF files in .zip description				
	Document Description		Start	End	
	Specification		1	42	
	Claims		43	48	
	Abstract		49	49	
Warnings:					
Information:					
3	Drawings-only black and white line drawings	drawings_MPW3M1B_5-9-11.pdf	193858 6e1059be7ac0d568b2defab67d52c2a384a98306	no	6
Warnings:					
Information:					
4		Information_Disclosure_Statement_MPW3M1B_5-9-11.pdf	188586 a4b96d730835f485358b0b1f716628e4eabb10e	yes	8
	Multipart Description/PDF files in .zip description				
	Document Description		Start	End	
	Transmittal Letter		1	2	
Information Disclosure Statement (IDS) Filed (SB/08)		3	8		
Warnings:					
Information:					
5	Fee Worksheet (PTO-875)	fee-info.pdf	33144 62eaf015c4b027b6039d0fd32233fe37b439fa5	no	2
Warnings:					
Information:					

This Acknowledgement Receipt evidences receipt on the noted date by the USPTO of the indicated documents, characterized by the applicant, and including page counts, where applicable. It serves as evidence of receipt similar to a Post Card, as described in MPEP 503.

New Applications Under 35 U.S.C. 111

If a new application is being filed and the application includes the necessary components for a filing date (see 37 CFR 1.53(b)-(d) and MPEP 506), a Filing Receipt (37 CFR 1.54) will be issued in due course and the date shown on this Acknowledgement Receipt will establish the filing date of the application.

National Stage of an International Application under 35 U.S.C. 371

If a timely submission to enter the national stage of an international application is compliant with the conditions of 35 U.S.C. 371 and other applicable requirements a Form PCT/DO/EO/903 indicating acceptance of the application as a national stage submission under 35 U.S.C. 371 will be issued in addition to the Filing Receipt, in due course.

New International Application Filed with the USPTO as a Receiving Office

If a new international application is being filed and the international application includes the necessary components for an international filing date (see PCT Article 11 and MPEP 1810), a Notification of the International Application Number and of the International Filing Date (Form PCT/RO/105) will be issued in due course, subject to prescriptions concerning national security, and the date shown on this Acknowledgement Receipt will establish the international filing date of the application.

Under the Paperwork Reduction Act of 1995, no persons are required to respond to a collection of information unless it contains a valid OMB control number.

Application Data Sheet 37 CFR 1.76		Attorney Docket Number	MPW 3M1B
		Application Number	
Title of Invention	BLOW-MOLDED WHEELS HAVING UNDERCUT TREADS, METHODS FOR PRODUCING THE SAME, AND CHILDREN'S RIDE-ON VEHICLES INCLUDING THE SAME		
The application data sheet is part of the provisional or nonprovisional application for which it is being submitted. The following form contains the bibliographic data arranged in a format specified by the United States Patent and Trademark Office as outlined in 37 CFR 1.76. This document may be completed electronically and submitted to the Office in electronic format using the Electronic Filing System (EFS) or the document may be printed and included in a paper filed application.			

Secrecy Order 37 CFR 5.2

Portions or all of the application associated with this Application Data Sheet may fall under a Secrecy Order pursuant to 37 CFR 5.2 (Paper filers only. Applications that fall under Secrecy Order may not be filed electronically.)

Applicant Information:

Applicant 1				
Applicant Authority		<input checked="" type="radio"/> Inventor		<input type="radio"/> Legal Representative under 35 U.S.C. 117
				<input type="radio"/> Party of Interest under 35 U.S.C. 118
Prefix	Given Name	Middle Name	Family Name	Suffix
	Albert	L.	Arendt	
Residence Information (Select One) <input checked="" type="radio"/> US Residency <input type="radio"/> Non US Residency <input type="radio"/> Active US Military Service				
City	West Seneca	State/Province	NY	Country of Residence US
Citizenship under 37 CFR 1.41(b)		US		
Mailing Address of Applicant:				
Address 1	141 Willowdale Drive			
Address 2				
City	West Seneca	State/Province	NY	
Postal Code	14224	Country	US	
Applicant 2				
Applicant Authority		<input checked="" type="radio"/> Inventor		<input type="radio"/> Legal Representative under 35 U.S.C. 117
				<input type="radio"/> Party of Interest under 35 U.S.C. 118
Prefix	Given Name	Middle Name	Family Name	Suffix
	James	R.	Carducci	
Residence Information (Select One) <input checked="" type="radio"/> US Residency <input type="radio"/> Non US Residency <input type="radio"/> Active US Military Service				
City	East Aurora	State/Province	NY	Country of Residence US
Citizenship under 37 CFR 1.41(b)		US		
Mailing Address of Applicant:				
Address 1	129 Maple Street			
Address 2				
City	East Aurora	State/Province	NY	
Postal Code	14052	Country	US	
Applicant 3				
Applicant Authority		<input checked="" type="radio"/> Inventor		<input type="radio"/> Legal Representative under 35 U.S.C. 117
				<input type="radio"/> Party of Interest under 35 U.S.C. 118
Prefix	Given Name	Middle Name	Family Name	Suffix
	Christopher	F.	Lucas	
Residence Information (Select One) <input checked="" type="radio"/> US Residency <input type="radio"/> Non US Residency <input type="radio"/> Active US Military Service				
City	Cheektowaga	State/Province	NY	Country of Residence US

Under the Paperwork Reduction Act of 1995, no persons are required to respond to a collection of information unless it contains a valid OMB control number.

Application Data Sheet 37 CFR 1.76		Attorney Docket Number	MPW 3M1B	
		Application Number		
Title of Invention	BLOW-MOLDED WHEELS HAVING UNDERCUT TREADS, METHODS FOR PRODUCING THE SAME, AND CHILDREN'S RIDE-ON VEHICLES INCLUDING THE SAME			
Citizenship under 37 CFR 1.41(b)	US			
Mailing Address of Applicant:				
Address 1	38 Monterey Lane			
Address 2				
City	Cheektowaga	State/Province	NY	
Postal Code	14225	Country	US	
All Inventors Must Be Listed - Additional Inventor Information blocks may be generated within this form by selecting the Add button. <input type="button" value="Add"/>				

Correspondence Information:

Enter either Customer Number or complete the Correspondence Information section below. For further information see 37 CFR 1.33(a).			
<input type="checkbox"/> An Address is being provided for the correspondence information of this application.			
Customer Number	78569		
Email Address		<input type="button" value="Add Email"/>	<input type="button" value="Remove Email"/>

Application Information:

Title of the Invention	BLOW-MOLDED WHEELS HAVING UNDERCUT TREADS, METHODS FOR PRODUCING THE SAME, AND CHILDREN'S RIDE-ON VEHICLES INCLUDING THE SAME		
Attorney Docket Number	MPW 3M1B	Small Entity Status Claimed	<input type="checkbox"/>
Application Type	Nonprovisional		
Subject Matter	Utility		
Suggested Class (if any)		Sub Class (if any)	
Suggested Technology Center (if any)			
Total Number of Drawing Sheets (if any)	6	Suggested Figure for Publication (if any)	7

Publication Information:

<input type="checkbox"/> Request Early Publication (Fee required at time of Request 37 CFR 1.219)
<input type="checkbox"/> Request Not to Publish. I hereby request that the attached application not be published under 35 U.S.C. 122(b) and certify that the invention disclosed in the attached application has not and will not be the subject of an application filed in another country, or under a multilateral international agreement, that requires publication at eighteen months after filing.

Representative Information:

Representative information should be provided for all practitioners having a power of attorney in the application. Providing this information in the Application Data Sheet does not constitute a power of attorney in the application (see 37 CFR 1.32). Enter either Customer Number or complete the Representative Name section below. If both sections are completed the Customer Number will be used for the Representative Information during processing.			
Please Select One:	<input checked="" type="radio"/> Customer Number	<input type="radio"/> US Patent Practitioner	<input type="radio"/> Limited Recognition (37 CFR 11.9)

Under the Paperwork Reduction Act of 1995, no persons are required to respond to a collection of information unless it contains a valid OMB control number.

Application Data Sheet 37 CFR 1.76		Attorney Docket Number	MPW 3M1B
		Application Number	
Title of Invention	BLOW-MOLDED WHEELS HAVING UNDERCUT TREADS, METHODS FOR PRODUCING THE SAME, AND CHILDREN'S RIDE-ON VEHICLES INCLUDING THE SAME		
Customer Number	78569		

Domestic Benefit/National Stage Information:

This section allows for the applicant to either claim benefit under 35 U.S.C. 119(e), 120, 121, or 365(c) or indicate National Stage entry from a PCT application. Providing this information in the application data sheet constitutes the specific reference required by 35 U.S.C. 119(e) or 120, and 37 CFR 1.78(a)(2) or CFR 1.78(a)(4), and need not otherwise be made part of the specification.

Prior Application Status	Pending	<input type="button" value="Remove"/>			
Application Number	Continuity Type	Prior Application Number	Filing Date (YYYY-MM-DD)		
	Continuation of	12577565	2009-10-12		
Prior Application Status	Patented	<input type="button" value="Remove"/>			
Application Number	Continuity Type	Prior Application Number	Filing Date (YYYY-MM-DD)	Patent Number	Issue Date (YYYY-MM-DD)
12577565	Division of	11509421	2006-08-23	7621543	2009-11-24

Additional Domestic Benefit/National Stage Data may be generated within this form by selecting the **Add** button.

Foreign Priority Information:

This section allows for the applicant to claim benefit of foreign priority and to identify any prior foreign application for which priority is not claimed. Providing this information in the application data sheet constitutes the claim for priority as required by 35 U.S.C. 119(b) and 37 CFR 1.55(a).

<input type="button" value="Remove"/>			
Application Number	Country ¹	Parent Filing Date (YYYY-MM-DD)	Priority Claimed
			<input type="radio"/> Yes <input checked="" type="radio"/> No

Additional Foreign Priority Data may be generated within this form by selecting the **Add** button.

Assignee Information:

Providing this information in the application data sheet does not substitute for compliance with any requirement of part 3 of Title 37 of the CFR to have an assignment recorded in the Office.

Assignee 1			
If the Assignee is an Organization check here. <input checked="" type="checkbox"/>			
Organization Name	Mattel, Inc.		
Mailing Address Information:			
Address 1	333 Continental Boulevard		
Address 2			
City	El Segundo	State/Province	CA
Country	US	Postal Code	90245
Phone Number		Fax Number	
Email Address			

Under the Paperwork Reduction Act of 1995, no persons are required to respond to a collection of information unless it contains a valid OMB control number.

Application Data Sheet 37 CFR 1.76	Attorney Docket Number	MPW 3M1B
	Application Number	
Title of Invention	BLOW-MOLDED WHEELS HAVING UNDERCUT TREADS, METHODS FOR PRODUCING THE SAME, AND CHILDREN'S RIDE-ON VEHICLES INCLUDING THE SAME	

Additional Assignee Data may be generated within this form by selecting the **Add** button.

Signature:

A signature of the applicant or representative is required in accordance with 37 CFR 1.33 and 10.18. Please see 37 CFR 1.4(d) for the form of the signature.

Signature			Date (YYYY-MM-DD)	2011-05-09	
First Name	Ian D.	Last Name	Gates	Registration Number	51722

This collection of information is required by 37 CFR 1.76. The information is required to obtain or retain a benefit by the public which is to file (and by the USPTO to process) an application. Confidentiality is governed by 35 U.S.C. 122 and 37 CFR 1.14. This collection is estimated to take 23 minutes to complete, including gathering, preparing, and submitting the completed application data sheet form to the USPTO. Time will vary depending upon the individual case. Any comments on the amount of time you require to complete this form and/or suggestions for reducing this burden, should be sent to the Chief Information Officer, U.S. Patent and Trademark Office, U.S. Department of Commerce, P.O. Box 1450, Alexandria, VA 22313-1450. DO NOT SEND FEES OR COMPLETED FORMS TO THIS ADDRESS. **SEND TO: Commissioner for Patents, P.O. Box 1450, Alexandria, VA 22313-1450.**

**BLOW-MOLDED WHEELS HAVING UNDERCUT TREADS,
METHODS FOR PRODUCING THE SAME, AND CHILDREN'S RIDE-ON VEHICLES
INCLUDING THE SAME**

5 Related Applications

The present application is a continuation application of, and claims priority under 35 U.S.C. § 120 to, U.S. Patent Application Serial No. 12/577,565, which was filed on October 12, 2009, issued on May 10, 2011 as U.S. Patent No. 7,939,008, and the complete disclosure of which is hereby incorporated by reference. U.S. Patent Application Serial No. 12/577,565 is a divisional of and claims priority to U.S. Patent Application Serial No. 11/509,421, which was filed on August 23, 2006, and issued on November 24, 2009 as U.S. Patent No. 7,621,543, and the complete disclosure of which is hereby incorporated by reference.

Field of the Disclosure

15 The present disclosure relates to children's ride-on vehicles, and more particularly to blow-molded wheels for children's ride-on vehicles and methods for producing the same.

Background of the Disclosure

Children's ride-on vehicles are reduced-scale vehicles that are designed and sized for use by children. For example, children's ride-on vehicles include a seat adapted to accommodate one or more children as well as steering and drive assemblies that are adapted to be operated by a child sitting on the seat. The drive assembly is adapted to drive the rotation of one or more of the vehicle's wheels and may include a battery-powered motor assembly or a manually powered drive assembly, such as a pedal-powered drive assembly.

The wheels used on children's ride-on vehicles are often blow-molded from a suitable material, such as a plastic. Blow-molded wheels are conventionally formed using a mold that has two portions, which typically separate in an axial direction. The portions of the mold collectively define a cavity that defines, or corresponds to, the shape of the blow-molded wheels, including the tread surface. The seam, or part line, between the axially-separating mold portions typically defines, or corresponds to, the central circumferential portion of the wheel. During the blow-molding process, a parison of molten plastic is introduced into the mold cavity and a pressurized gas, such as air, is used to force the molten plastic against the internal surface of the cavity in order to form a hollow wheel having a shape defined by the internal surface of the cavity. After a cooling period, the mold portions are separated, and the blow-molded wheel is removed.

Blow-molded articles, including blow-molded wheels, as well as the corresponding molds and processes used to produce such articles, should be configured to permit removal of the finished article from the mold without deforming, tearing, or otherwise damaging the finished article. Projections or hollows on the surface of a blow-molded article typically correspond to hollows or projections on the inner surface of the corresponding mold. Removal of a completed blow-molded article from its mold withdraws the mold projections from hollows on the blow-molded article. Similarly, the projections on the surface of the blow-molded article are removed from the hollows on the inner surface of the mold during mold removal. When such projections or hollows are oriented generally parallel to the direction of mold removal, the projections on the mold or article are simply pulled out of the corresponding hollow

during mold removal. In contrast, when the projections or hollows on a blow-molded article are not oriented generally parallel to the direction of mold removal, such as when they are oriented generally perpendicular to the direction of mold removal, such projections or hollows may be said to overlap corresponding portions of the mold with respect to the direction of mold-removal. Blow-molded articles that have projections or hollows that overlap corresponding portions of the mold with respect to the direction of mold-removal are commonly referred to as being “undercut.”

Small undercuts may be permissible because blow-molded articles tend to shrink slightly during cooling, such that the article may pull away from the mold and release the overlap. Further, blow-molded articles may permit a small amount of elastic deformation or deflection, which may be sufficient to release small undercuts. However, undercuts over a certain threshold may effectively lock a blow-molded article into its mold. In particular, if an undercut is too large, the shrinkage and/or potential elastic deformation of the blow-molded article may be insufficient to permit removal of the finished article without damage. Conventionally, blow-molded wheels must have undercuts of $\frac{1}{8}$ inch (3.175 millimeters) or less so that they may be removed from the molds used to form the wheels.

As discussed above, blow-molded wheels are typically blown in a mold that opens in an axial direction. By using a mold that opens in an axial direction, blow-molded wheels may have significant axially oriented projections or hollows, such as may be used to form or detail the hub region of the wheel. However, in order to avoid significant undercuts that might lock a blow-molded wheel into its mold, the design of the tread surface on a blow-molded wheels is typically of limited complexity. In the case

of blow-molded wheels used with children's ride-on vehicles, which are often intended to resemble full-sized vehicles, the limited complexity of the tread designs typically provided on blow-molded wheels limits the realism of the blow-molded wheels, which are often intended to resemble rubber tires.

5

Summary of the Disclosure

The present disclosure is directed to blow molded wheels having undercut treads, methods for producing the same, and children's ride-on vehicles including the same.

The blow-molded wheels may include a blow-molded body that has a tread
10 surface, first and second sidewalls and an axis. The body may be configured to rotate about the axis. The tread surface may extend circumferentially around the body and may extend between the first and second sidewalls. A first region of the tread surface may be disposed between the first sidewall and the central circumference of the blow-molded body. A second region of the tread surface may be disposed between the
15 second sidewall and the central circumference of the blow-molded body. A recessed region may be positioned between the first and second regions of the tread surface, with a radial distance from the axis to the recessed region being less than radial distances from the axis to the first and second regions of the tread surface.

The blow-molded wheels may be used in a children's ride-on vehicle. The
20 children's ride-on vehicle may include a body having at least one seat sized for a child and a plurality of wheels rotatably coupled to the body. The plurality of wheels may include at least one driven wheel and at least one steerable wheel. The children's ride-on vehicle may further include a steering assembly and a drive assembly. The steering

assembly may include a steering mechanism adapted to receive steering inputs from a child sitting on the at least one seat and a steering linkage adapted to convey the steering inputs to the at least one steerable wheel. The drive assembly may be adapted to selectively drive the rotation of the at least one driven wheel.

5

Brief Description of the Drawings

Fig. 1 is a perspective view of a children's ride-on vehicle having at least one blow-molded wheel according to the present disclosure.

Fig. 2 is a top plan view of the children's ride-on vehicle of Fig. 1 with another
5 example of blow-molded wheels according to the present disclosure.

Fig. 3 is a schematic diagram of an illustrative, non-exclusive example of a motorized drive assembly suitable for use with a children's ride-on vehicle, such as a children's ride-on vehicle having at least one blow-molded wheel according to the present disclosure.

10 Fig. 4 is a schematic diagram of an illustrative, non-exclusive example of a manually powered drive assembly suitable for use with a children's ride-on vehicle, such as a children's ride-on vehicle having at least one blow-molded wheel according to the present disclosure.

Fig. 5 is a perspective view of an illustrative example of a blow-molded wheel
15 that has undercut tread portions and is suitable for use with a children's ride-on vehicle, such as the vehicle of Fig. 1.

Fig. 6 is a partial sectional view of the wheel of Fig. 5, taken generally along line 6-6 in Fig. 5.

Fig. 7 is a perspective view of another illustrative example of a blow-molded
20 wheel that has undercut tread portions and is suitable for use with a children's ride-on vehicle, such as the vehicle of Fig. 1.

Fig. 8 is an exploded perspective view of a first portion of a simplified mold for producing a wheel that has undercut tread portions, such as a wheel similar to the

wheel of Fig. 5, with the pinch-off ring shown separated from the main mold portion, with one of the mold slides shown in a release position.

Fig. 9 is a plan view of the mold portion of Fig. 8, shown with the pinch-off ring omitted, with one of the mold slides shown in a release position and one of the mold
5 slides in a retracted position.

Fig. 10 is a sectional view of the mold a first portion of Fig. 8, taken generally along line 10-10 in Fig. 9, with the pinch off shown attached to the main mold portion, with one of the mold slides shown in a retracted position.

Detailed Description and Best Mode of the Disclosure

An illustrative, non-exclusive example of a children's ride-on vehicle is shown in Fig. 1 and indicated generally at 10. Ride-on vehicle 10 includes a support frame, or body, 12 that provides a riding space, or passenger compartment, 14 with a seat assembly 16 that is sized and configured to accommodate at least one child, including a child driver. Seat assembly 16 may be integral with or otherwise mounted on body 12 and may have any suitable configuration, including configurations in which the position of the seat assembly is adjustable within the passenger compartment, and configurations in which the seat assembly includes two or more seats or two or more seating regions. Typically, vehicle 10 will be sized for use by a child driver or by a child driver and a child passenger. For example, in the illustrated embodiment, seat assembly 16 includes a pair of seats, or seating regions, 18 and 20, with seat 18 sized and positioned to receive a child driver and seat 20 sized and positioned to receive a child passenger.

Body 12 typically is formed from molded plastic and may be integrally formed or formed from a plurality of parts that are secured together by screws, bolts, clips or other suitable fasteners. Body 12 may additionally, or alternatively, be at least partially formed from other suitable material(s), such as metal, wood, or composite materials. Body 12 may include, or be mounted upon, an underlying frame, or chassis, or chassis portion, on which the rest of the body (which may be referred to as a body portion) is supported. The chassis portion may be formed from the same or different materials as the rest of the body; when present, the chassis portion is often formed of metal and/or

molded plastic, with the body portion typically being formed of molded plastic. However, these illustrative examples of suitable materials of construction are not required.

As shown, body 12 is shaped to generally resemble a reduced-scale Jeep® vehicle. JEEP is a registered trademark of the Daimler Chrysler Corporation, and the
5 JEEP mark and designs are used by permission. Children's ride-on vehicles according to the present disclosure may be shaped to generally resemble any type of vehicle. Examples of suitable vehicles are reduced-scale, or child-sized, vehicles that are shaped to resemble corresponding full-sized, or adult-sized, vehicles, such as cars, trucks, construction vehicles, emergency vehicles, off-road vehicles, motorcycles, space
10 vehicles, aircraft, watercraft and the like. However, it is also within the scope of the present disclosure that vehicle 10 may be shaped to resemble fantasy vehicles that do not have a corresponding adult-sized counterpart. Although vehicle 10 is depicted in the form of a reduced-scale Jeep® vehicle, it will be appreciated that the components and/or features of vehicle 10 may be configured for use on any type of children's ride-on
15 vehicle.

Vehicle 10 also includes a plurality of wheels 22 that are rotatably coupled to body 12, as indicated in Figs. 1-2. As discussed in more detail herein, the plurality of wheels includes at least one blow-molded wheel, such as at least one wheel having an undercut tread, such as one or more of the illustrative wheels shown and/or discussed
20 with respect to Figs. 5-7. The plurality of wheels includes a steerable wheel assembly 24 that contains at least one steerable wheel that is adapted to be steered by the vehicle's steering assembly 26, typically at least partially in response to user-imparted steering inputs thereto. The plurality of wheels further includes a driven wheel

assembly 28 that contains at least one driven wheel that is adapted to be rotationally driven by the vehicle's drive assembly 30. As used herein, the term "driven wheel" refers to a wheel that is rotated in response to a rotational input from the vehicle's drive assembly, which is either directly conveyed to the wheel by the output of a motor assembly or pedal assembly, or which is conveyed through a linkage, such as a gearbox, belt, chain, gear assembly, axle, or the like.

In the illustrated embodiment, vehicle 10 includes four wheels 22, with front wheels 32 and 34 forming steerable wheel assembly 24, and rear wheels 36 and 38 forming driven wheel assembly 28. The number of wheels on the vehicle may vary from two wheels to three, four, six, or more wheels. However, children's ride-on vehicles typically include at least three wheels for stability. Similarly, each wheel assembly must contain at least one wheel, and a particular wheel may form all or a portion of both the steerable wheel assembly and the driven wheel assembly. For example, it is within the scope of the disclosure that either or both of front wheels 32 and 34 or rear wheels 36 and 38 are driven and steerable. Similarly, one front wheel and one rear wheel may be driven and/or steerable, or the vehicle may include one or more driven or steerable wheels underneath its body that are generally hidden by the body of the vehicle.

Some or all of the plurality of wheels 22 may include a hub portion 39 and a tire portion 40, as indicated in Fig. 1. When present, the hub and tire portions may be integrally formed, or the hub and tire portions may be formed as separate parts that are secured together by screws, bolts, clips, adhesives, or other suitable fasteners or fastening methods. The hub and tire portions may be formed from the same or different materials. In some embodiments, hub portion 39 and tire portion 40 may be formed

from materials having different colors, such as differently colored plastics. For example, hub portion 39 may (but is not required to) be formed from a silver-colored plastic to simulate a metal hub, while tire portion 40 may (but is not required to) be formed from a black-colored plastic to simulate a rubber tire.

5 A portion of the vehicle's steering assembly 26 is shown in Figs. 1 and 2 and includes a steering column 41 (indicated in Fig. 2) and a steering mechanism 42. The steering assembly enables a child sitting on seat 18 to steer the vehicle's steerable wheel assembly 24 via user-applied steering inputs to steering mechanism 42, which is positioned on vehicle 10 for operation by a child sitting on seat 18. In the illustrated
10 embodiment, steering mechanism 42 takes the form of a steering wheel 44. Other suitable structures, such as handlebars and steering levers may be used and are within the scope of the present disclosure. Steering column 41 includes any suitable mechanical linkage that conveys a child's steering inputs from the steering mechanism to the vehicle's steerable wheel assembly, thereby steering the vehicle.

15 In Fig. 3, an illustrative, non-exclusive example of a suitable drive assembly 30 for a children's ride-on vehicle, such as vehicle 10, is schematically illustrated. Drive assembly 30 is adapted to drive the rotation of driven wheel assembly 28. The drive assembly 30 may be referred to as a motorized drive assembly 31 and includes a motor assembly 46, which includes at least one electric motor, such as battery-powered
20 motor 48, that is adapted to drive the rotation of at least one of the plurality of wheels. The motor assembly 46 includes an output 50 that provides a rotational input to the driven wheel assembly 28, such as to the hub portion of one or more of the wheels 22 in driven wheel assembly 28. Typically, the output 50 from each of the at least one motors

includes a rotating shaft and/or a rotating pinion or output gear. Output 50 may include more than one shaft, pinion, and/or gear, such as when motor assembly 46 includes more than one motor and/or when driven wheel assembly 28 includes more than one driven wheel. Motor assembly 46 may also be configured to power other moveable
5 components on vehicle 10, such as depending on the form of the vehicle. For example, the motor assembly 46 may be coupled to raise and lower the blade of a ride-on that resembles a bulldozer, the bucket of a ride-on that resembles a skid-steer or other loader, the bed of a ride-on that resembles a dump truck, etc.

Power for the motor assembly 46 may be provided by battery assembly 54.
10 Battery assembly 54 includes at least one rechargeable battery, or cell, 56 that is adapted to provide power to the motor assembly. The batteries in battery assembly 54 may be able to be selectively disconnected from the motor assembly and connected to a charging assembly to recharge the batteries. Any suitable type and number of batteries, or cells, may be used in battery assembly 54. For example, one or more six-,
15 twelve-, eighteen-, or twenty-four-volt batteries have proven effective. The motor assembly 46 may be operably connected to the battery assembly 54 by any suitable electrical connectors, such as cables, wires, positive and negative terminals or leads, one or more plugs and corresponding sockets, and the like.

In Fig. 3, drive assembly 31 is shown further including an optional motor output
20 linkage 60 that mechanically interconnects the motor assembly 46 with the driven wheel assembly 28. Motor output linkage 60 is any suitable mechanism that transmits the rotational input from the motor assembly's output(s) to the driven wheel assembly 28, such as to the hub portion of one or more of the wheels 22 in driven wheel assembly 28.

Examples of suitable linkages include an intermediate linkage between the output 50 of the motor assembly 46 and the driven wheel assembly 28, such as a gearbox containing one or more gears, a belt or chain drive, a worm gear, one or more individual gears, and the like. The motor output linkage 60 may be adapted to transmit the rotational input from the output 50 to the driven wheel assembly 28 at the same relative rate of rotation, or it may mechanically augment the rotational input to convey a greater or lesser rate of rotation relative to the rate of rotation of the output 50. It is also within the scope of the disclosure that drive assembly 31 may be formed without motor output linkage 60, in which case rotational input from the output(s) of the motor assembly 46 may be directly transmitted to the driven wheel assembly 28.

As schematically illustrated in Fig. 3, drive assembly 31 may also include one or more user input devices 62 that are adapted to convey inputs from a child sitting on seat 18 to the drive assembly. User input devices 62 also may be referred to as user control devices. These devices convey a user's inputs, such as via the vehicle's wiring harness 66, and affect the actuation of the motor assembly 46, such as by causing the actuation (or energization) of the motor assembly, selecting between a range of electronic configurations, selecting the direction of rotation of the motor assembly's output 50, selecting the relative degree of a maximum rate of rotation to which the motor assembly is actuated, etc. Examples of suitable user input devices 62 include a drive actuator 68, through which a user input directing the battery assembly 54 to energize the motor assembly 46 is received. Examples of suitable drive actuators 68 include an on/off switch, a foot pedal, a throttle lever, and a rotational handgrip on a steering mechanism that includes a handlebar. In Fig. 2, an example of a drive actuator 68 is

shown in the form of a foot pedal 70 positioned for actuation by a child sitting on seat 18. When drive actuator 68 takes a form other than a foot pedal, it may be located in any suitable location within or near passenger compartment 14 so that a child sitting on seat 18 may reach the actuator while positioned to operate vehicle 10. For example, an on/off switch or throttle may be located on the body or on the steering mechanism 42, such as illustrated at 72 in Fig. 2.

As schematically illustrated in Figs. 2 and 3, other examples of user input devices 62 include a speed switch 74, which enables a user to select the relative rate of rotation of the motor assembly's output 50, and a direction switch 76, which enables a user to select the relative direction (i.e., clockwise or counterclockwise) of rotation of output 50 and thereby configure the vehicle 10 to drive in forward and reverse directions. Switches 74 and 76 may be located in any suitable location on body 12 or steering assembly 26 for actuation by a child sitting on seat 18. An example of a suitable speed switch 74 is a switch that selectively configures a pair of batteries between series and parallel configurations to define relative "high" and "low" speed configurations. Speed switch 74 may additionally or alternatively selectively configure a pair of motors between series and parallel configurations. As a further example, the switches may convey inputs to a controller, such as subsequently described controller 78, which, responsive to inputs from the switches, configures vehicle 10 for a selected operating state.

As illustrated in Fig. 3, drive assembly 31 may (but is not required to) further include a controller 78, which is adapted to control electronically the transmission of the rotational input from the motor assembly 46 to the driven wheel assembly 28. More

specifically, controller 78 may include a microprocessor or suitable control circuit that is adapted to control the actuation, or energization, of the motor assembly 46 by the battery assembly 54 to regulate electronically the rotational input transmitted by the motor assembly 46 to the driven wheel assembly 28. Controller 78 may regulate at least one of the timing and the ramp, or rate, of application of the transmission of the rotational input after actuation of a corresponding user input device 62 by a child sitting on seat 18. In other words, the controller 78 may delay in at least time and/or rate of transmission the rotational input to the driven wheel assembly 28 responsive at least in part to a user input selecting the desired, or selected, rotational input. An illustrative example of a suitable controller is disclosed in U.S. Patent No. 6,771,034, the complete disclosure of which is hereby incorporated by reference for all purposes. As used herein, the one or more user input devices 62 and, when present, controller 78 that are adapted to configure the vehicle's drive assembly 31 between a plurality of operating states may be referred to collectively as the vehicle's speed control assembly 80.

As shown in Fig. 2, body 12 may also include at least one battery compartment 82 that is adapted to receive battery assembly 54. The battery compartment may take any of a variety of different shapes, sizes, and configurations depending on such factors as the form of vehicle 10, the portion of the vehicle's body within which the compartment is formed, and the size and shape of battery assembly 54. Fig. 2 provides graphical illustrations of several suitable, non-exclusive positions for battery compartment 82. The battery compartment may include a cover or other closure to selectively restrict access to the battery assembly during use of the

vehicle. The compartment may additionally or alternatively include a suitable retainer to position and/or secure the battery assembly within the battery compartment.

The previously described drive assembly provided an example of a motorized drive assembly having at least one battery-powered motor. It is also within the scope of the present disclosure that children's ride-on vehicles 10 according to the present disclosure may additionally or alternatively include a manually powered drive assembly. As an illustrative example, a manually powered drive assembly may include a pedal assembly having pedals that are coupled to at least one of the plurality of wheels so that the wheels are rotatably driven as a child seated on seat 18 reciprocates the pedals. An illustrative, non-exclusive example of a suitable pedal assembly is disclosed in U.S. Patent No. 6,651,528, the complete disclosure of which is hereby incorporated by reference for all purposes. An illustrative, non-exclusive example of a drive assembly 30 in the form of a manually powered drive assembly is schematically illustrated in Fig. 4 and generally indicated at 33. As illustrated, drive assembly 33 is a pedal-powered drive assembly in which driven wheel assembly 28 is operatively coupled to a pedal assembly 84 having pedals 86. Reciprocating rotation of pedals 86 drives the rotation of driven wheel assembly 28. It is also within the scope of the present disclosure that children's ride-on vehicles 10 having bodies 12 may be formed without a drive assembly and therefore may be adapted to be propelled by a child seated on seat 18 pushing the vehicle with the child's feet in a foot-to-floor manner, or by an adult who pushes the vehicle through any suitable mechanism.

In Figs. 5 and 6, an illustrative, non-exclusive example of a blow-molded wheel according to the present disclosure is shown at 90. As illustrated, wheel 90 has

undercut tread portions. Unless otherwise specified, blow-molded wheel 90 may, but is not required to, contain at least one of the structures, components, functionality, and/or variations as the other blow-molded wheels described and/or illustrated herein. Wheel 90 includes a blow-molded wheel body 92 that is configured to rotate about an axis 94. Children's ride-on vehicles 10 according to the present disclosure may include one or more wheels 90.

As shown in Figs. 5 and 6, blow-molded body 92 may be configured to generally resemble an un-mounted vehicle tire such that blow-molded body 92 forms a tire portion that may be suitably attached to a separate hub portion to form a wheel, as discussed above. However, it is within the scope of this disclosure for some embodiments of blow-molded body 92 to additionally include some or all of the hub portion of a wheel, such as where the blow-molded body integrally includes a tire portion and a hub portion. This is somewhat schematically illustrated in Fig. 6, in which portions of an integral hub portion 39 are shown in dashed lines. In such an embodiment, at least portions of the internal surface of body 92, such as the region extending between sidewalls 96 and 98 and opposed to tread surface 100 may not be present

The blow-molded molded body 92 may include first and second sidewalls 96 and 98, and a tread surface 100 that extends circumferentially around the blow-molded body. In some embodiments, tread surface 100 may be configured to resemble the traction-enhancing tread patterns that may typically be found on the wheels of full-sized vehicles, such as the rubber tires found on automobiles, trucks, off-road vehicles, or the like, or any of the various types of steel tires found on some forms of construction or other industrial vehicles. As shown in the illustrative, non-exclusive example presented

in Figs. 5 and 6, the tread surface 100 extends circumferentially around body 92 and generally extends between the first and second sidewalls 96 and 98. Tread surface 100 may be integrally blow-molded with body 92, as shown in Figs. 5 and 6 and generally described herein. However, it is within the scope of this disclosure for some
5 embodiments of wheel 92 to include a tread surface 100 that forms at least a portion of a separately blow-molded part that may be secured to blow-molded body 92 using screws, bolts, clips, adhesives, or other suitable fasteners or fastening methods.

As used herein, tread surface 100 and the various regions thereof, which will be described more fully herein, refer to the external features, structures, and surfaces of
10 the blow-molded body 92 exclusive of any particular internal structure that may, or may not, be present within the blow-molded wheel 90 and/or the blow-molded body 92. It is within the scope of the present disclosure for the various portions and regions of blow-molded body 92 to be of any suitable thickness, either constant or varying, and the shape and/or structure of the various internal surfaces or regions of blow-molded
15 body 92 may, or may not, correspond to the adjacent external surfaces. For example, although a projection on the external surface of the blow-molded body may correspond to a recess on the internal surface of the blow-molded body, as shown in Fig. 6, it is within the scope of the present disclosure for a projection on the external surface to correspond to a relatively uniform portion of the internal surface or even to a projection
20 on the internal surface.

The blow-molded body 92 may have a part line 102, as shown in dashed lines in Fig. 5. Part line 102 may correspond to a seam on the blow-molded body that is created by the interface between the portions of the mold used to mold blow-molded

body 92, which process will be more fully discussed below. As shown in Fig. 5, part line 102 may be a planar closed curve, such as a circle, that extends around the circumference 104 of blow-molded body 92. However, it is also within the scope of the present disclosure for part line 102 to have a non-planar and/or non-circular shape. For example, part line 102 may undulate around the circumference of blow-molded body 92, such as where the radial distance from axis 94 to part line 102 varies around the circumference of the blow-molded body 92 and/or where the axial position of part line 102 relative to the first and second sidewalls 96 and 98 varies around the circumference of the blow-molded body 92.

10 The tread surface 100 may include a first region 106 and a second region 108, as shown in Figs. 5 and 6. The first region 106 of tread surface 100 may include the portion, or portions, of tread surface 100 that is, or are, located a first radial distance 110 from the axis 94 and is, or are, disposed between the first sidewall 96 and the part line 102 of the blow-molded body 92. The second region 108 of tread surface 100 may include the portion, or portions, of tread surface 100 that is, or are, located a second radial distance 112 from the axis 94 and is, or are, disposed between the first region 106 and the part line 102 of the blow-molded body 92. As shown in the illustrative, non-exclusive example presented in Fig. 6, the first radial distance 110 from the axis 94 to the first region 106 exceeds the second radial distance 112 from the axis 15 to the second region 108 by at least a first predetermined threshold 114.

20 In some embodiments, tread surface 100 may, but is not required to, include a third region 116, as shown in Figs. 5 and 6. The third region 116 of tread surface 100 may include the portion, or portions, of the tread surface 100 that is, or are, located a

third radial distance 118 from the axis 94 and is, or are, disposed between the second region 108 of tread surface 100 and the second sidewall 98 of the blow-molded body 92. As shown in the illustrative, non-exclusive example presented in Fig. 6, the third radial distance 118 from the axis 94 to the third region 116 exceeds the second radial distance 112 from the axis 94 to the second region 108 by at least a second predetermined threshold 120. Further, as shown in the illustrative, non-exclusive example presented in Fig. 6, the third radial distance 118 from the axis 94 to the third region 116 may exceed the first radial distance 110 from the axis 94 to the first region 106. However, it is within the scope of the present disclosure for one or more of the first radial distance 110 from the axis 94 to the first region 106 and the second radial distance 112 from the axis to the second region 108 to exceed the third radial distance 118 from the axis 94 to the third region 116. Further, it is within the scope of the present disclosure for the third radial distance 118 to be equal, or approximately equal to, the first radial distance 110.

15 In some embodiments, tread surface 100 may include a fourth region 122, as shown in Figs. 5 and 6. The fourth region 122 of tread surface 100 may include the portion, or portions, of the tread surface 100 that is, or are, located a fourth radial distance 124 from the axis 94 and is, or are, disposed between at least a first portion 126 of the third region 116 of tread surface 100 and the second sidewall 98 of the blow-molded body 92. As shown in the illustrative, non-exclusive example presented in Fig. 6, the third radial distance 118 from the axis 94 to the third region 116 may exceed the fourth radial distance 124 from the axis 94 to the fourth region 122 by at least a third predetermined threshold 128. The fourth region 122 of tread surface 100

may be disposed between the part line 102 and the second sidewall 98, as shown in the illustrative, non-exclusive example presented in Figs. 5 and 6. However, it is within the scope of the present disclosure for at least a portion of the fourth region 122 to be disposed between the part line 102 and the first sidewall 96. As shown in the illustrative, non-exclusive example presented in Fig. 6, the fourth radial distance 124 may be approximately equal to the second radial distance 112. However, it is within the scope of the present disclosure for the fourth radial distance 124 to be greater than or less than the second radial distance 112.

In some embodiments, a second portion 130 of the third region 116 of tread surface 100 may define a fifth region 132 of tread surface 100 that is disposed between the fourth region 122 and the second sidewall 98. As shown in the illustrative, non-exclusive example presented in Figs. 5 and 6, the fifth region 132 of tread surface 100 is located a fifth radial distance 134 from the axis 94. Further, as shown in the illustrative, non-exclusive example presented in Fig. 6, the fifth radial distance 134 from the axis 94 to the fifth region 132 may exceed the fourth radial distance 124 from the axis 94 to the fourth region 122 by at least a fourth predetermined threshold 136. The third radial distance 118 from the axis 94 to the first portion 126 of the third region 116 may exceed the fifth radial distance 134 from the axis 94 to the fifth region 132, as shown in the illustrative, non-exclusive example presented in Fig. 6. However, it is within the scope of the present disclosure for the fifth radial distance 134 from the axis 94 to the fifth region 132 to exceed the third radial distance 118 from the axis 94 to the first portion 126 of the third region 116. Further, it is within the scope of the present disclosure for the fifth radial distance 134 to be equal, or approximately equal to, one or

more of the first radial distance 110 and the third radial distance 118 from the axis 94 to the first portion 126 of the third region 116.

At least one of the first predetermined threshold 114, second predetermined threshold 120, third predetermined threshold 128, and fourth predetermined threshold 136, such as the first predetermined threshold 114 and/or the fourth predetermined threshold 136, may be functionally related to the manufacturing process and mold used to fabricate the blow-molded body 92. The first predetermined threshold 114 corresponds to the situation at which the first radial distance 110 sufficiently exceeds the second radial distance 112 such that any cooling-induced shrinkage of blow-molded body 92, which may occur after blowing (i.e., formation of the wheel in the mold), and/or the extent to which blow-molded body 92 may be elastically deflected or deformed as the mold portions are separated to permit removal of the wheel therefrom, either alone or in combination, are insufficient to provide removal clearance, or the ability to otherwise remove the blow-molded body 92 without damage, between the first region 106 of the tread surface 100 of blow-molded body 92 and the portion of the mold corresponding to the second region 108 of the tread surface 100 of blow-molded body 92. In particular, when the portion of the mold corresponding to the second region 108 of the tread surface 100 is in the molding position (as will be more fully discussed below) and the first radial distance 110 exceeds the second radial distance 112 by more than the first predetermined threshold 114, the portion of the mold corresponding to the second region 108 of the tread surface 100 may prevent removal of the finished blow-molded body from its mold without damaging the first region 106 of the tread surface 100 of the blow-molded body 92. Similarly, the fourth predetermined

threshold 136 corresponds to the situation at which the fifth radial distance 134 sufficiently exceeds the fourth radial distance 124 such that the cooling induced shrinkage of blow-molded body 92, which occurs after blowing, and/or the extent to which blow-molded body 92 may be elastically deflected, either alone or in combination, are insufficient to provide removal clearance, or the ability to otherwise remove the blow-molded body 92 without damage, between the fifth region 132 of the tread surface 100 of blow-molded body 92 and the portion of the mold corresponding to the fourth region 122 of the tread surface 100 of blow-molded body 92. Thus, the first predetermined threshold 114, second predetermined threshold 120, third predetermined threshold 128, or fourth predetermined threshold 136, such as the first predetermined threshold 114 and/or the fourth predetermined threshold 136, may vary depending on such factors as the diameter of the blow-molded body, the material of the blow-molded body, including its thermal and mechanical properties, the molding conditions such as temperature and cooling time, or the like.

As illustrative, non-exclusive examples, any one or more of the first predetermined threshold 114, second predetermined threshold 120, third predetermined threshold 128, or fourth predetermined threshold 136 may be at least (approximately) 2 mm (millimeters), 3 mm, 4 mm, 5 mm, 6 mm, 10 mm, 12.7 mm, 25 mm, or more. Similarly, any one or more of the first predetermined threshold 114, second predetermined threshold 120, third predetermined threshold 128, or fourth predetermined threshold 136 may be at least (approximately) 0.1%, 0.5%, 1%, 2%, 5%, or even 10% or more of a diameter of blow-molded body 92, which may correspond to a

diameter of part line 102, which may correspond to twice the radial distance from axis 94 to part line 102, such as twice the third radial distance 118.

As shown in the illustrative, non-exclusive example presented in Figs. 5 and 6, any one or more of first region 106, second region 108, third region 116, fourth
5 region 122, and fifth region 132 may be a circumferentially continuous region extending around the circumference of the blow-molded body 92, which may be at a constant radial distance from the axis 94. However, it is within the scope of the present disclosure for one or more of first region 106, second region 108, third region 116,
fourth region 122, and fifth region 132 to undulate around the circumference of the blow-
10 molded body 92, such as where the radial distance from the axis 94 to one or more of first region 106, second region 108, third region 116, fourth region 122, and fifth region 132 varies around the circumference of the blow-molded body 92.

Further, as shown in the illustrative, non-exclusive example presented in Figs. 5 and 6, any one or more of first region 106, second region 108, third region 116, fourth
15 region 122, and fifth region 132 may be of uniform width and be located at a constant distance from part line 102. However, it is within the scope of the present disclosure for any one or more of first region 106, second region 108, third region 116, fourth region 122, and fifth region 132 to have a variable width and/or to be located at a variable distance from part line 102. For example, any one or more of first region 106,
20 second region 108, third region 116, fourth region 122, and fifth region 132 may vary in width around the circumference of the blow-molded body. Further, any one or more of first region 106, second region 108, third region 116, fourth region 122, and fifth region 132 may follow a wavy path around the circumference of the blow-molded body,

such as where one or more of the regions of tread surface 100 is relatively closer to part line 102 at some points around the circumference of the blow-molded body than at other points around the circumference of the blow-molded body where the region is further from part line 102.

5 The boundaries, or transition regions, 138 between adjacent ones of first region 106, second region 108, third region 116, fourth region 122, and fifth region 132 may be of any suitable configuration. For example, as shown in the illustrative, non-exclusive example presented in Fig. 6, the transition regions may be obliquely oriented to one or more of the adjacent ones of first region 106, second region 108, third
10 region 116, fourth region 122, and fifth region 132 and may include a radiused transition, or any other suitable type of smooth transition, to one or more of the adjacent ones of first region 106, second region 108, third region 116, fourth region 122, and fifth region 132. Exemplary angles at which a transition region may be oriented may include an angle in the range of 30 degrees to 150 degrees, such as an angle in the range of 45
15 and 135 degrees, in the range of 60 and 135 degrees, and/or in the range of 70 and 110 degrees. However, it is also within the scope of the present disclosure for one or more of the transition regions to be perpendicular to one or more of the adjacent ones of first region 106, second region 108, third region 116, fourth region 122, and fifth region 132 and/or to have an abrupt transition, such as an edge, to one or more of the adjacent
20 ones of first region 106, second region 108, third region 116, fourth region 122, and fifth region 132. As shown in the illustrative, non-exclusive example presented in Figs. 5 and 6, where the first region 106, second region 108, third region 116, fourth region 122, and fifth region 132 are of uniform width and located at a constant distance

from part line 102, the transition regions 138 may be of constant width around the circumference of the body. However, it is also within the scope of the present disclosure for one or more of the transition regions 138 to vary in one or more of width, angle to adjacent regions, and/or distance from the part line 102 around the
5 circumference of the blow-molded body.

In Fig. 7, another illustrative, non-exclusive example of a blow-molded wheel that has undercut tread portions according to the present disclosure is shown at 90. Unless otherwise specified, blow-molded wheel 90 may, but is not required to, contain at least one or more of the structures, components, functionality, and/or variations as the other
10 blow-molded wheels described and/or illustrated herein.

The blow-molded wheel shown in Fig. 7 provides an illustrative, graphical example that blow-molded wheels 90 according to the present disclosure may, but are not required to, include a blow-molded body 92 with a tread surface 100 that includes a plurality of circumferentially spaced-apart first regions 106 and/or a plurality of
15 circumferentially spaced-apart second regions 108. It is within the scope of the present disclosure that any of the plurality of circumferentially spaced-apart first regions 106 and/or a plurality of circumferentially spaced-apart second regions 108 may extend around the circumference of the blow-molded body 92 for any angular portion thereof, such as an angular portion between 0 and 360 degrees, such as an angular portion of
20 at least (approximately) 10 degrees, 15 degrees, 18 degrees, 20 degrees, 30 degrees, 36 degrees, 45 degrees, 60 degrees, or 90 degrees, or more. Further, any of the plurality of circumferentially spaced-apart first regions 106 may extend over a greater or lesser angular portion of the circumference of the blow-molded body 92 than a given

one of the plurality of circumferentially spaced-apart second regions 108. For example, at least one of the plurality of circumferentially spaced-apart first regions 106 may extend over an angular portion that is at least (approximately) 10%, 25%, 50%, 75%, 100%, 125%, 150%, 175%, 200%, or even 300% or more the size of the angular portion
5 over which at least one of the plurality of circumferentially spaced-apart second regions 108 extends.

In some embodiments, at least a portion of at least one of the circumferentially spaced-apart first regions 106 may overlap, or be at least partially axially aligned with, at least a portion of at least one of the plurality of circumferentially spaced-apart second
10 regions 108. For example, as shown in the illustrative, non-exclusive example presented in Fig. 7, at least a portion 140 of at least one of the circumferentially spaced-apart first regions 106 may be disposed between at least a portion 142 of at least one of the circumferentially spaced-apart second regions 108 and the first sidewall 96. Further, in some embodiments, at least a portion 144 of at least one of the
15 circumferentially spaced-apart second regions 108 may extend axially toward the first sidewall 96 between at least a portion 146 of adjacent ones of the plurality of circumferentially spaced-apart first regions 106, as shown in the illustrative, non-exclusive example presented in Fig. 7.

As shown in the illustrative, non-exclusive example presented in Fig. 7, the blow-
20 molded body 92 of blow-molded wheels 90 according to the present disclosure may include a base surface 148. In some embodiments, at least a portion of base surface 148 may define a first region 106 of tread surface 100 below which a plurality of spaced-apart circumferentially discontinuous regions 150 may be recessed, as shown in

the illustrative, non-exclusive example presented in Fig. 7. In such an embodiment, the plurality of spaced-apart circumferentially discontinuous recessed regions 150 may define a second region 108 of tread surface 100. In some embodiments, at least a portion of base surface 148 may define a second region 108 of the tread surface 100 from which a plurality of circumferentially spaced-apart tread blocks, or tread members, 152 project, as shown in the illustrative, non-exclusive example presented in Fig. 7. In such an embodiment, the plurality of circumferentially spaced-apart tread blocks 152 may define a first region 106 of the tread surface 100.

As shown in the illustrative, non-exclusive example presented in Fig. 7, some embodiments of blow-molded wheels 90 according to the present disclosure may include, as part of the tread surface, one or more optional channels 154, which (when present) may extend across the part line 102. Channels 154 may enhance the appearance or traction of tread surface 100. As shown in Fig. 7, channels 154 may be obliquely oriented relative to part line 102. In some embodiments, an optional web, or rib, 156 may extend across channel 154 such that the obliquely oriented channel 154 is divided at the part line into a pair of channels that do not cross the part line. Web 156 may be beneficial when using a rotary tool to remove mold flash from part line 102. In particular, by dividing the obliquely oriented channel 154 at part line 102, web 156 may provide blow-molded wheel 90 with a circular part line 102 from which mold-flash may be readily removed, such as with a rotary tool.

In some embodiments, a children's ride-on vehicle 10 with a plurality of wheels 22 that includes at least one blow-molded wheel 90 according to the present disclosure may only include blow-molded wheels 90, while in other embodiments, the

plurality of wheels may include one or more wheels that do not have the undercut tread described herein. As an illustrative, non-exclusive example of a children's ride-on vehicle in which the plurality of wheels are not all wheels 90, a children's ride-on vehicle 10 may include wheels 90 as its front wheels or its rear wheels, with the other
5 wheels having a different geometry or tread pattern, such as a geometry or tread pattern that does not include the undercut tread described herein with respect to wheels 90.

In Figs. 8-10, an illustrative, non-exclusive example of a first portion of a simplified mold 160 for producing a blow-molded wheel (90) that has undercut tread
10 portions according to the present disclosure is shown at 170. Unless otherwise specified, the second portion of the mold (not shown) may, but is not required to, contain at least one of the structures, components, functionality, and/or variations as the first mold portion described and/or illustrated herein. In some embodiments, the second mold portion may be a mirror image, or at least substantially identical to, the first mold
15 portion, although this is not required. Although mold portion 170 is simplified, relevant portions of mold portion 170 will be discussed with regard to the corresponding portions of the various embodiments of blow-molded wheel 90 discussed above. However, it should be understood that a mold that is based on mold portion 170 may be used to manufacture any blow-molded wheel that has undercut tread portions, which may, but is
20 not required to, contain at least one of the structures, components, functionality, and/or variations as any of the blow-molded wheels described and/or illustrated herein. Further, it is within the scope of the present disclosure that wheels 90 according to the present disclosure may be manufactured in any suitable mold and/or molding process,

which may, but is not required to, contain at least one of the structure, components, functionality, and/or variations of the mold portion described and/or illustrated herein.

As illustrated in Figs. 8 and 10, mold portion 170 may include a main, or primary, mold portion 172, at least one pinch-off ring 174, a first tread-molding portion 176, and at least one second tread-molding portion 178. The main mold portion 172 includes a cavity 180 that has an internal surface 182 that is configured to define the exterior shape of at least a portion of a wheel that is blow-molded or otherwise formed within cavity 180. The internal surface 182 includes a sidewall molding portion 184 that is configured to mold a first sidewall, such as first sidewall 96, of a wheel that is blow-molded or otherwise formed within cavity 180. As illustrated in the simplified example of Figs. 8-10, the main mold portion, first and second tread molding portions 176 and 178, and internal surface 182 are depicted as having smooth surfaces oriented to contact, or define the shape of the wheel (90) formed in the mold. This configuration is not required. In some embodiments, at least one or more of these portions and/or surfaces may have one or more of irregular configurations, ridges, projections, depressions, channels, tread-defining portions, and the like. As a more specific example, it should be understood that a mold for producing the wheel 90 of Fig. 5 will have differently shaped portions and/or surfaces than a mold for producing the wheel 90 of Fig. 7, even though both are within the scope of the present disclosure.

The at least one pinch-off ring 174 of the first mold portion 170 is configured to engage the at least one pinch-off ring of the second mold portion (not shown) when the first and second mold portions are brought together to form a full mold cavity during a molding operation. The interface between the pinch-off rings of the first and second

mold portions when the mold is closed may define the part line of the mold, and thereby define a part line, or seam, of a wheel produced in the mold. As shown in Figs. 8 and 10, pinch-off ring 174 may have a planar configuration, which would correspond to a planar part line on blow-molded wheel 90 that may lie in a plane that is normal to axis 94 of blow-molded wheel 90.

As shown in Figs. 8 and 10, pinch-off ring 174 may include an opening 186, which may be configured to form a circumference or part line on a blow-molded wheel, such as a wheel similar to blow-molded wheel 90. As shown in the illustrative, non-exclusive example presented in Figs. 8 and 10, the pinch-off ring 174 may have a squared-off, or otherwise rectilinear, edge or corner. However, it is within the scope of the present disclosure for pinch-off ring 174 to include a sharpened edge for impingement on a parison when the first and second mold portions are brought together to form the full mold cavity during the molding process.

One or more of the pinch-off rings used with first mold portion 170 may be a distinct component from main mold portion 172. For example, as shown in Figs. 8 and 10, pinch-off ring 174 may be a part of a pinch-off plate 188 that may be attached to, or otherwise positioned relative to, main mold portion 172. When used with main mold portion 172, pinch-off plate 188 may form at least a portion of cavity 180 and/or internal surface 182, as shown in Figs. 8 and 10. Pinch-off plate 188 may be attached to first mold portion 170 using any suitable attachment method, such as bolts, adhesives, clips, welding, or the like. Pinch-off plate 188 may be removably, permanently, or semi-permanently attached to mold portion 170. Use of a removable or

semi-permanent attachment may improve the lifespan of mold portion 170, such as by enabling repair, replacement, and/or substitution of pinch-off plate 188.

In some embodiments, pinch-off plate 188 may be fabricated from a material different than the material used for main mold portion 172 to address the different
5 conditions that the various mold components may experience during use. For example, the internal surface 182 of the mold cavity 180 may experience relatively little wear during use such that the main mold portion 172 may be fabricated from relatively softer material, such as aluminum. In contrast, pinch-off rings 174 may experience relatively greater wear during use, such as when pinch-off ring 174 includes a sharpened edge,
10 which may tend to dull during extended use. Thus, the wear properties and/or the tool life of pinch-off plate 188 may be improved if pinch-off plate 188 is fabricated from a harder material than is used for main mold portion 172. Illustrative, non-exclusive examples of materials that may be suitable for pinch-off plate 188 may include a nickel-copper alloy, such as Ampcoloy 940, which has a Rockwell hardness of 94B and is sold
15 by Ampco Metal Inc. of Arlington Heights, Illinois, or a beryllium-copper alloy, such as MoldMAX HH®, which has a Rockwell hardness of 40C and is sold by Brush Wellman Incorporated of Cleveland, Ohio. Other materials may be used within the scope of the present disclosure, with the above being illustrative, non-exclusive examples.

As illustrated in Figs. 8-10, first tread-molding portion 176 may be configured to
20 mold a first region of the tread surface of a wheel that is blow-molded or otherwise formed within cavity 180, such as wheel 90. For example, first tread-molding portion 176 may be configured to mold a first region 106 of the tread surface 100 that is

disposed between the first sidewall 96 and the part line 102, which is defined by interface between the first and second mold portions, as shown in Figs. 8-10.

As shown in Figs. 8-10, at least one of the at least one second tread-molding portion 178 may be configured to mold a second region of the tread surface of a wheel that is blow-molded or otherwise formed within cavity 180, such as wheel 90. For example, second tread-molding portion 178 may be configured to mold a second region 108 of the tread surface 100 that is disposed between the first region 106 and the part line 102 that is defined by the interface between the first and second mold portions, as shown in Figs. 8-10. In some embodiments, the second tread-molding portion 178 may be configured to mold a plurality of circumferentially spaced-apart tread blocks on the second region of the tread surface, such as those shown on the illustrative, non-exclusive example of wheel 90 that is presented in Fig. 7.

As shown in the illustrative, non-exclusive example presented in Figs. 8-10, the at least one second tread-molding portion 178 may include plural radially spaced second tread-molding portions 178. As illustrative, non-exclusive examples, the at least one second tread-molding portion 178 may include 2, 3, 4, 5, 6, 7, 8, 9, 10, or even 12 or more radially spaced second tread-molding portions 178. Each of the at least one second tread-molding portion 178 may subtend any suitable angle. As illustrative, non-exclusive examples, any one or more of the at least one second tread-molding portion 178 may subtend an angle of approximately 180 degrees, 120 degrees, 90 degrees, 72 degrees, 60 degrees, 51.4 degrees, 45 degrees, 40 degrees, 36 degrees, 30 degrees, 20 degrees, 15 degrees, 10 degrees, and/or an angle in the range of 0-180 degrees, 10-40 degrees, 20-50 degrees, 30-60 degrees,

40-100 degrees, 60-140 degrees, 70-160 degrees, 80-100 degrees, 115-180 degrees, or any other suitable angle or range of angles. In some embodiments, each of the at least one second tread-molding portion 178 may subtend an equal angle. In some embodiments, each of the at least one second tread-molding portion 178 may subtend
5 an angle equal to 360 degrees divided by the number of plural radially spaced second tread-molding portions. For example, as shown in the illustrative, non-exclusive example presented in Figs. 8-10, the at least one second tread-molding portion 178 may include five second tread-molding portions, each of which subtend an angle of 72 degrees. However, it is within the scope of the present disclosure for the plural radially
10 spaced second tread-molding portions to cumulatively subtend an angle of less than 360 degrees, such as where the second region 108 of the tread surface 100 is circumferentially discontinuous.

In the illustrative example shown in Figs. 8-10, the second tread-molding portions 178 are oriented in a coplanar, radially spaced-apart configuration. This is an
15 illustrative, but not exclusive, example. It is within the scope of the present disclosure that the second tread-molding portions of a mold portion for a mold for producing wheels 90 may include one or more of discontinuously spaced second tread-molding portions, more than one coplanar plurality of radially spaced second tread-molding portions, second tread-molding portions that extend in non-radial orientations to each
20 other, etc.

The at least one second tread-molding portion 178 may be a portion of a movable mold portion, or mold slide, 190 that is configured to move inwardly and outwardly relative to the first tread-molding portion 176. In some embodiments, all of

the second tread-molding portions 178 will form portions of movable mold portions 190. In particular, movable mold portion 190 may be configured to cause the at least one second tread-molding portion 178 to move inwardly and outwardly relative to the first tread-molding portion 176 between at least a molding position 192 and a release position 194, as shown in the illustrative, non-exclusive example presented in Figs. 8 and 9.

As shown in the illustrative, non-exclusive example presented in Figs. 9 and 10, the second tread-molding portion 178, as a portion of movable mold portion 190, is in the molding position 192 when a first radial distance 196 from an axis 198 (which may be an axis of symmetry and may correspond to the axis 94 of wheel 90) of first mold portion 170 to at least a first region (200) of the first tread-molding portion 176 exceeds a second radial distance 202 from axis 198 to at least a second region (204) of the second tread-molding portion 178 by a first predetermined threshold. The first predetermined threshold may correspond to the situation at which the first radial distance 196 sufficiently exceeds the second radial distance 202 such that any cooling-induced shrinkage, which may occur after blowing, of the blow-molded wheel (90) produced in simplified mold 160 and/or the extent to which the blow-molded wheel (90) may be elastically deflected, either alone or in combination, are insufficient to provide removal clearance, or the ability to otherwise remove the blow-molded wheel (90) without damage, between the second region (204) of the second tread-molding portion 178 and the portion of the tread surface of the blow-molded wheel (90) that is molded by the first region (200) of the first tread-molding portion 176, when the second tread-molding portion 178, as a portion of movable mold portion 190, is in the molding

position 192. In some embodiments, the first predetermined threshold may be selected such that the blow-molded wheel may not be removed from the first and second mold portions without damaging the wheel unless the at least one second tread-molding portion is in the release position. In some embodiments, the first predetermined threshold may be selected to exceed the distance between the blow-molded wheel and a portion of the mold cavity in which the wheel is formed, such as the first tread-molding portion, and in some embodiments, it may exceed this distance by at least 1, 2, 3, 4, 5, 6, 8, 10, or more millimeters.

As illustrative, non-exclusive examples, the first predetermined threshold may be at least (approximately) 2 mm (millimeters), 3 mm, 4 mm, 5 mm, 6 mm, 10 mm, 12.7 mm, 25 mm, or more. Similarly, the first predetermined threshold may be at least (approximately) 0.1%, 0.5%, 1%, 2%, 5%, or even 10% or more of the diameter of the opening 186 of pinch-off ring 174. As shown in the illustrative, non-exclusive example presented in Figs. 8-10, when the second tread-molding portion 178 is in the molding position 192, the radial distance from axis 198 to every portion of the second tread-molding portion 178 may be less than the radial distance from axis 198 to every portion of the first tread-molding portion 176. However, it is within the scope of the present disclosure for the radial distance from axis 198 to only certain portions of the second tread-molding portion 178 to be less than the radial distance from axis 198 to every portion of the first tread-molding portion 176. In some embodiments, the second radial distance 202 from axis 198 to second region 204 may correspond to the minimum radial distance from axis 198 to the second tread-molding portion 178 when movable mold portion 190 is in the molding position 192.

As shown in the illustrative, non-exclusive example presented in Fig. 9, the second tread-molding portion 178, as a portion of movable mold portion 190, is in the release position 194 when a third radial distance 206 from the axis 198 to a third region 208 of the second tread-molding portion 178 is at least as great as a distance that corresponds to a fourth radial distance 210 less a second predetermined threshold. The fourth radial distance 210 is the distance from the axis 198 to a fourth region 212 of the first tread-molding portion 176, where the fourth region 212 is the region of the first tread-molding portion 176 that is adjacent the third region 208 of the second tread-molding portion 178 when the second tread-molding portion 178, as a portion of movable mold portion 190, is in the release position 194. In particular, as shown in the illustrative, non-exclusive example presented in Fig. 9, where the second tread-molding portion 176 is configured to have a uniform minimum radial distance when second tread-molding portion 176 is in the molding position 192 and when movable mold portion 190 is translated outward from the molding position 192, the second tread-molding portion 176 will be closest to axis 94 (i.e., will have a minimum radial distance to axis 94) at end regions 214 (which correspond to third region 208). Thus, in the illustrative, non-exclusive example presented in Figs. 8 and 9, the second tread-molding portion 178 will be in release position 194 when the radial distance from axis 94 to end regions 214 is not less than (other than by the second predetermined threshold) fourth radial distance 210. However, it is within the scope of the present disclosure for either or both of third radial distance 206 and fourth radial distance 210 to vary or undulate around the circumference of cavity 180. Thus, the second tread-molding portion 178, as a portion of movable mold portion 190, may be in a release position when any given

portion of the second tread-molding portion 178 is no closer to axis 198 (other than by the second predetermined threshold) than whichever portion of the first tread-molding portion 176 is immediately adjacent to the given portion of the second tread-molding portion 178 when the second tread-molding portion 178 is in a particular position
5 relative to the first tread-molding portion 176.

The second predetermined threshold corresponds to the extent by which the third radial distance 206 from the axis 198 to a third region 208 of the second tread-molding portion 178 may be less than the fourth radial distance 210 (as defined above) and still provide removal clearance, or the ability to otherwise remove the blow-molded
10 wheel (90) without damage, between the third region 208 of the second tread-molding portion 178 and the portion of the tread surface of the blow-molded wheel (90) that is molded by the fourth region (212) of the first tread-molding portion 176, when the second tread-molding portion 178, as a portion of movable mold portion 190, is in the release position 194. As illustrative, non-exclusive examples, the second
15 predetermined threshold may be at least (approximately) zero millimeters, 1 mm (millimeters), 2 mm, 3 mm, 4 mm, 5 mm, 6 mm, 10 mm, 12.7 mm, 25 mm, or more. In some embodiments, the second predetermined threshold may be a negative value, such that, even when the second tread-molding portion 178 is in the release position, at least a given portion of the second tread-molding portion 178 may remain closer to
20 axis 198 than whichever portion of the first tread-molding portion 176 is immediately adjacent to the given portion of the second tread-molding portion 178 when the second tread-molding portion 178 is in the release position. In such an embodiment, removal clearance, or the ability to otherwise remove the blow-molded wheel (90) without

damage, may be provided by cooling induced shrinkage of the blow-molded wheel and/or the extent to which the blow-molded wheel (90) may be elastically deflected, either alone or in combination. As illustrative, non-exclusive examples, the second predetermined threshold may be less than (i.e., a greater negative value) (approximately) zero millimeters, -1 mm, -2 mm, -3 mm, or even greater negative values.

As shown in the illustrative, non-exclusive example presented in Figs. 8-10, each of the movable mold portions 190 may be provided with an actuator 216. Each of the actuators 216 may be configured to move the corresponding movable mold portion 190, as well as corresponding the second tread-molding portion 178, inwardly and outwardly, such as between the molding position 192 and the release position 194. Suitable actuator types may include pneumatic, hydraulic, electric, or any other type of actuator capable of producing the desired motion, which may be linear, arcuate, or the like. As shown in the illustrative, non-exclusive example presented in Figs. 8-10, the actuators 216 may move the corresponding movable mold portion 190 linearly radially inwardly and outwardly. However, it is within the scope of the present disclosure for the actuators 216 to move the movable mold portions 190 in a different manner, such as pivotingly or the like. In some embodiments, the actuators 216 may additionally be configured to move the corresponding movable mold portion 190, as well as corresponding the second tread-molding portion 178, to a retracted position 218, as shown in Figs. 9 and 10.

Wheels 90 that have undercut tread portions according to the present disclosure may be produced using a blow-molding process, although it is also within the scope of

the present disclosure that the wheels (90) that are described and/or illustrated herein may additionally or alternatively be formed from another suitable process, such as an injection molding process. Therefore, while wheels 90 have been described herein as being blow-molded wheels, they may alternatively be formed by other processes without
5 departing from the scope of the present disclosure. However, in many applications, wheels 90 will be formed from a blow-molding process, which has proven to be cost-effective and reliable. Any suitable plastic or other moldable material may be used to produce wheels 90 according to the present disclosure. The particular choice of materials may vary from application to application, and may vary according to one or
10 more of such illustrative factors as design preferences, wheel size, ride-on vehicle size, ride-on vehicle speed range, ride-on vehicle load-carrying capacity, expected terrain, etc.

A mold suitable for blow-molding a wheel that has undercut tread portions may include first and second mold portions that collectively define a mold cavity that is
15 configured to mold a wheel having a tread surface, first and second sidewalls and an axis. The first and second mold portions may be configured to separate in a direction that is parallel to the axis of the wheel. Unless otherwise specified, one or both of the first and second mold portions may, but are not required to, contain at least one of the structures, components, functionality, and/or variations as the mold portion
20 described and/or illustrated herein.

When a wheel 90 is produced by a blow-molding process in such a mold, a parison of molten material, such as a plastic, may be formed and positioned between the first and second mold portions. The first and second mold portions may be closed

on the parison. Either before or after the first and second mold portions are closed on the parison, at least one mold slide may be moved inward toward a molding position such that a tread-molding portion may extend into the mold cavity to form an undercut tread portion for a blow-molded wheel, such as a blow molded wheel having undercut
5 treads.

A pressurized gas may be injected into the parison such that the parison may be blown into a blow-molded wheel that has a shape that corresponds to the shape of the mold cavity defined by the first and second mold portions, including the first and second tread-molding portions. The shape of the resulting blow-molded wheel may include first
10 and second regions 106 and 108 of the tread surface 100 that correspond to the first and second tread-molding portions 176 and 178.

Prior to separating the first and second mold portions, the at least one mold slide may be moved from the molding position toward the release position such that the undercut tread portion of the blow-molded wheel may be released from the mold. The
15 first and second mold portions may be separated to release the resulting blow-molded wheel from the mold, such as after an optional, and often brief, cool-down period. Subsequent to release from the mold, any portions of the parison that remain attached to the blow-molded wheel may be removed using any suitable method. For example,
20 when the pinch-off rings include a squared-off edge, as discussed above, any portions of the parison that remain outside the mold cavity (i.e., molding "flash") may be removed with a rotary tool. However, when the pinch-off rings include a sharpened edge, as discussed above, any molding flash may be only minimally attached to the finished

blow-molded wheel and may be readily removed, such as by snapping off the molding flash by hand or another suitable process.

Industrial Applicability

The present disclosure is applicable to blow-molded wheels, methods for
5 producing the same, and children's ride-on vehicles including the same.

It is believed that the disclosure set forth herein encompasses multiple distinct inventions with independent utility. While each of these inventions has been disclosed in its preferred form, the specific embodiments thereof as disclosed and illustrated herein are not to be considered in a limiting sense as numerous variations are possible.

10 The subject matter of the disclosure includes all novel and non-obvious combinations and subcombinations of the various elements, features, functions and/or properties disclosed herein. Similarly, where the claims recite "a" or "a first" element or the equivalent thereof, such claims should be understood to include incorporation of one or more such elements, neither requiring nor excluding two or more such elements.

15 It is believed that the following claims particularly point out certain combinations and subcombinations that are directed to one of the disclosed inventions and are novel and non-obvious. Inventions embodied in other combinations and subcombinations of features, functions, elements and/or properties may be claimed through amendment of the present claims or presentation of new claims in this or a related application. Such
20 amended or new claims, whether they are directed to a different invention or directed to the same invention, whether different, broader, narrower or equal in scope to the original claims, are also regarded as included within the subject matter of the inventions of the present disclosure.

CLAIMS:

1. A children's ride-on vehicle, comprising:

a vehicle body having at least one seat sized for a child;

a plurality of wheels rotatably coupled to the vehicle body, wherein the plurality of wheels includes at least one driven wheel and at least one steerable wheel, wherein at least one of the plurality of wheels is a blow-molded wheel that comprises:

a blow-molded wheel body having a diameter, an outer surface, first and second sidewalls, a central circumference, and an axis, wherein the blow-molded wheel body is configured to rotate about the axis, wherein the outer surface and the central circumference extend circumferentially around the blow-molded wheel body and between the first and second sidewalls, and wherein the central circumference is equidistant from the first and second sidewalls;

a first region of the outer surface, wherein the first region is disposed between the first sidewall and the central circumference of the blow-molded wheel body;

a second region of the outer surface, wherein the second region is disposed between the second sidewall and the central circumference of the blow-molded wheel body; and

a recessed region between the first region and the second region, wherein the first region and the second region are directly adjacent to the recessed region, and wherein a first radial distance from the axis to the first region and a second radial distance from the axis to the second region both exceed a third radial distance from the axis to the recessed region by at least the larger of 1/8 inch and 0.1% of the diameter.

2. The children's ride-on vehicle of claim 1, wherein the recessed region coincides with the central circumference.

3. The children's ride-on vehicle of claim 1, wherein the recessed region overlaps the central circumference.

4. The children's ride-on vehicle of claim 1, wherein the blow-molded wheel body has a part line, and wherein the recessed region coincides with the part line.

5. The children's ride-on vehicle of claim 1, wherein the blow-molded wheel body has a part line, wherein the central circumference coincides with the part line, and wherein the recessed region overlaps the central circumference.

6. The children's ride-on vehicle of claim 1, wherein the first region and the second region of the outer surface are smooth around an entire circumference of the blow-molded wheel body.

7. The children's ride-on vehicle of claim 1, wherein the first radial distance and the second radial distance are generally constant around an entire circumference of the blow-molded wheel body.

8. The children's ride-on vehicle of claim 1, wherein the first region and the second region of the outer surface are substantially smooth around an entire circumference of the blow-molded wheel body.

9. The children's ride-on vehicle of claim 8, wherein the blow-molded wheel further comprises:

a third region of the outer surface, wherein the third region is disposed between the first sidewall and the first region; and

a fourth region of the outer surface, wherein the fourth region is disposed between the second sidewall and the second region;

wherein the third region and the fourth region include a plurality of tread blocks on the outer surface, wherein the plurality of tread blocks are separated and spaced apart from each other on the outer surface.

10. The children's ride-on vehicle of claim 9, wherein at least a subset of the plurality of tread blocks have more than one radial distance from the axis to the respective tread block.

11. The children's ride-on vehicle of claim 9, wherein at least a portion of the outer surface between the plurality of tread blocks is generally V-shaped.

12. The children's ride-on vehicle of claim 9, wherein at least a subset of the plurality of tread blocks are generally V-shaped.

13. The children's ride-on vehicle of claim 9, wherein at least a subset of the plurality of tread blocks are generally U-shaped.

14. The children's ride-on vehicle of claim 9, wherein at least a subset of the plurality of tread blocks are partially coextensive with the first region and the second region.

15. The children's ride-on vehicle of claim 9, wherein at least a subset of the plurality of tread blocks extend from an adjacent portion of the outer surface by at least the larger of 1/8 inch and 0.1% of the diameter.

16. The children's ride-on vehicle of claim 9, wherein at least a subset of the plurality of tread blocks include walls extending from a base surface to define the respective tread blocks, wherein the walls extend at least partially transverse across the outer surface at angles relative to the central circumference.

17. The children's ride-on vehicle of claim 9, wherein at least a subset of the plurality of tread blocks partially extend onto at least one of the first sidewall and the second sidewall.

18. The children's ride-on vehicle of claim 1, wherein the recessed region defines a channel having a generally rectangular cross-section and extending around an entire circumference of the blow-molded wheel body.

19. The children's ride-on vehicle of claim 18, wherein the channel extends around the central circumference of the blow-molded wheel body.

20. A children's ride-on vehicle, comprising:

a vehicle body having at least one seat sized for a child;

a plurality of wheels rotatably coupled to the vehicle body, wherein the plurality of wheels includes at least one driven wheel and at least one steerable wheel, wherein at least one of the plurality of wheels is a blow-molded wheel that comprises:

a blow-molded wheel body having a diameter, an outer surface, first and second sidewalls, a central circumference, and an axis, wherein the blow-molded wheel body is configured to rotate about the axis, wherein the outer surface and the central circumference extend circumferentially around the blow-molded wheel body and between the first and second sidewalls, and wherein the central circumference is equidistant from the first and second sidewalls;

a first region of the outer surface, wherein the first region is disposed between the first sidewall and the central circumference of the blow-molded wheel body, and wherein the first region is smooth with a first radial distance from the axis to the first region that is generally constant around an entire circumference of the blow-molded wheel body;

a second region of the outer surface, wherein the second region is disposed between the second sidewall and the central circumference of the blow-molded wheel body, and wherein the second region is smooth with a second radial

distance from the axis to the second region that is generally constant around an entire circumference of the blow-molded wheel body;

a recessed region between the first region and the second region, wherein the first region and the second region are directly adjacent to the recessed region, and wherein the first radial distance and the second radial distance both exceed a third radial distance from the axis to the recessed region by at least the larger of 1/8 inch and 0.1% of the diameter;

a third region of the outer surface, wherein the third region is disposed between the first sidewall and the first region, and wherein the third region includes a plurality of spaced-apart tread blocks on the outer surface; and

a fourth region of the outer surface, wherein the fourth region is disposed between the second sidewall and the second region, and wherein fourth region includes a plurality of spaced-apart tread blocks on the outer surface.

Abstract of the Disclosure

Improved blow-molded wheels, methods for producing the same, and children's ride-on vehicles including the same are disclosed. The blow-molded wheels may include a blow-molded body that has a tread surface, first and second sidewalls and an axis. The body may be configured to rotate about the axis. The tread surface may extend circumferentially around the body and may extend between the first and second sidewalls. A first region of the tread surface may be disposed between the first sidewall and the central circumference of the blow-molded body. A second region of the tread surface may be disposed between the second sidewall and the central circumference of the blow-molded body. A recessed region may be positioned between the first region and the second region with the radial distance to the recessed region being less than the radial distances to the first and second regions.

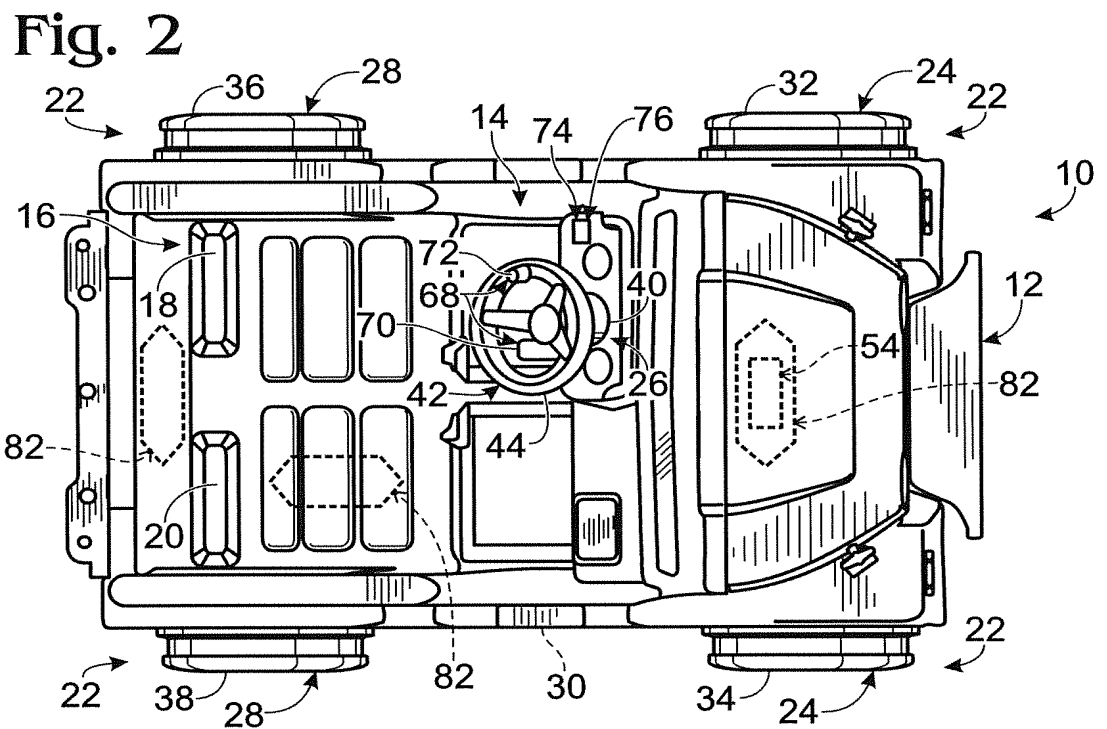
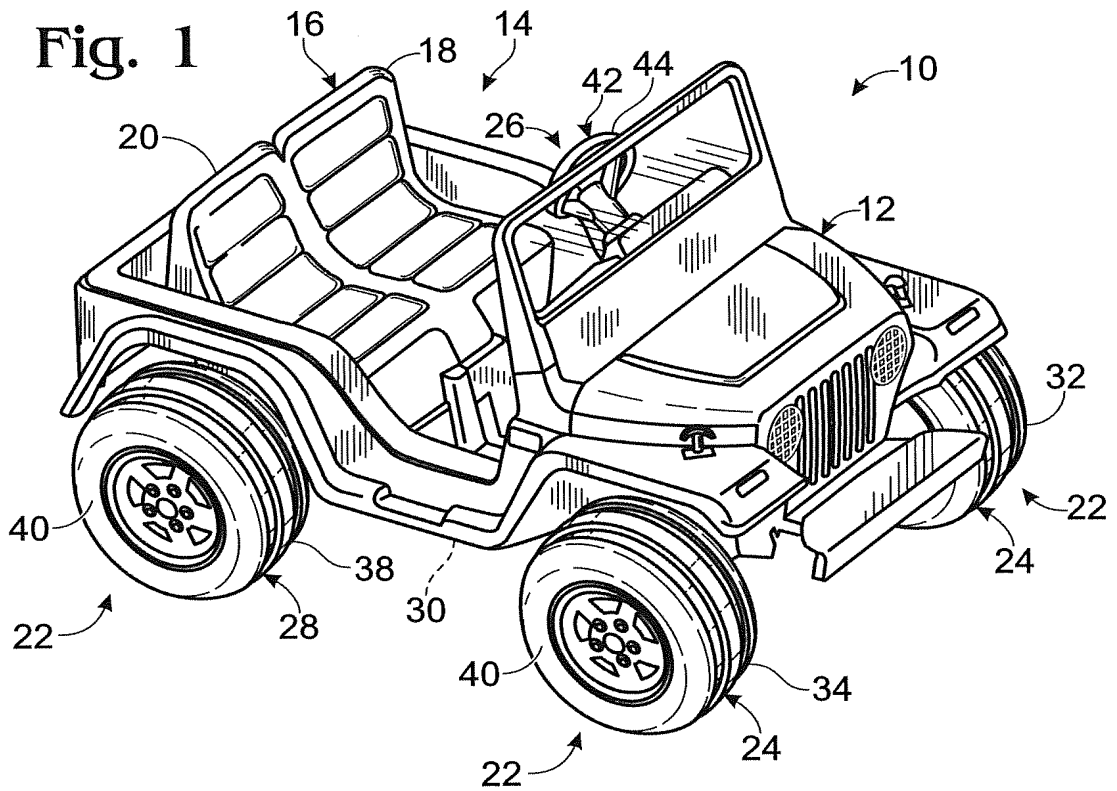

Fig. 3

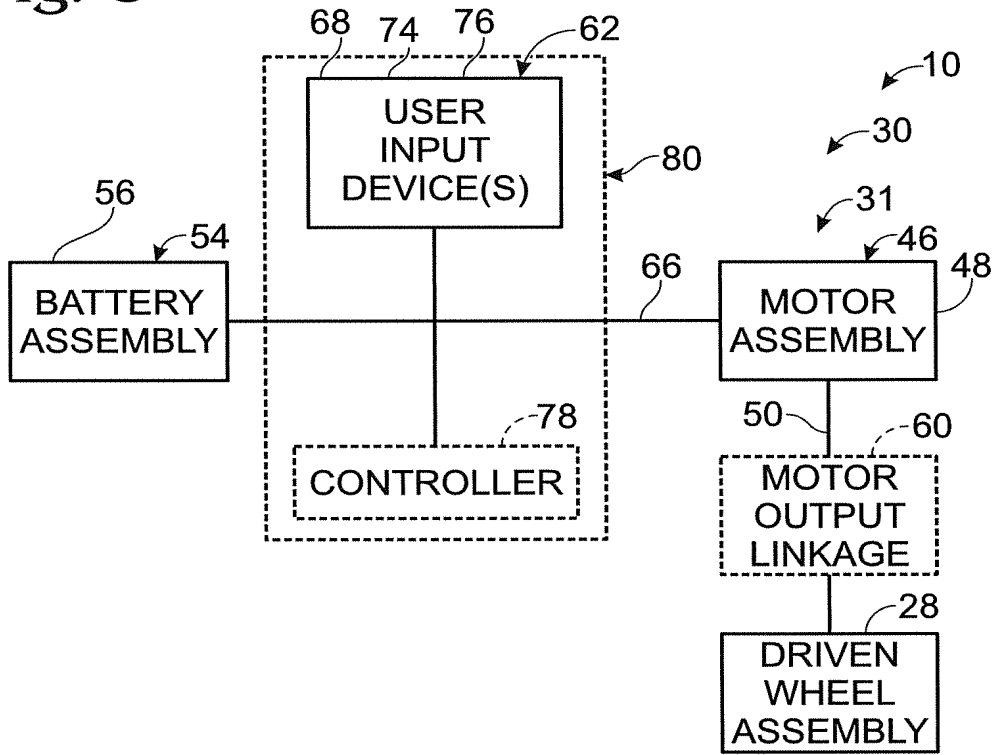
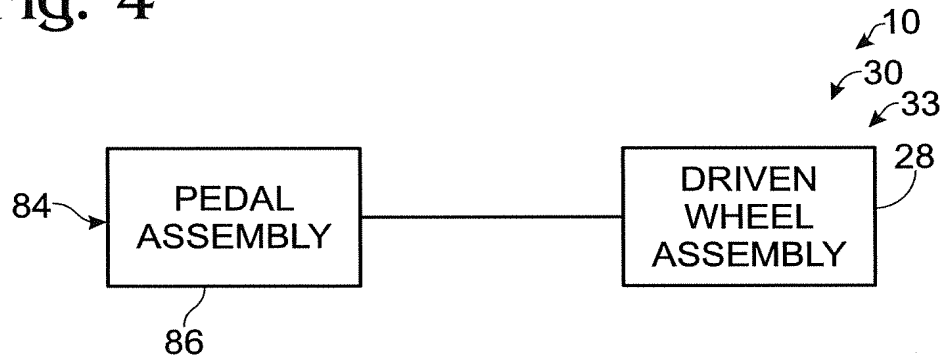

Fig. 4



3/6

Fig. 5

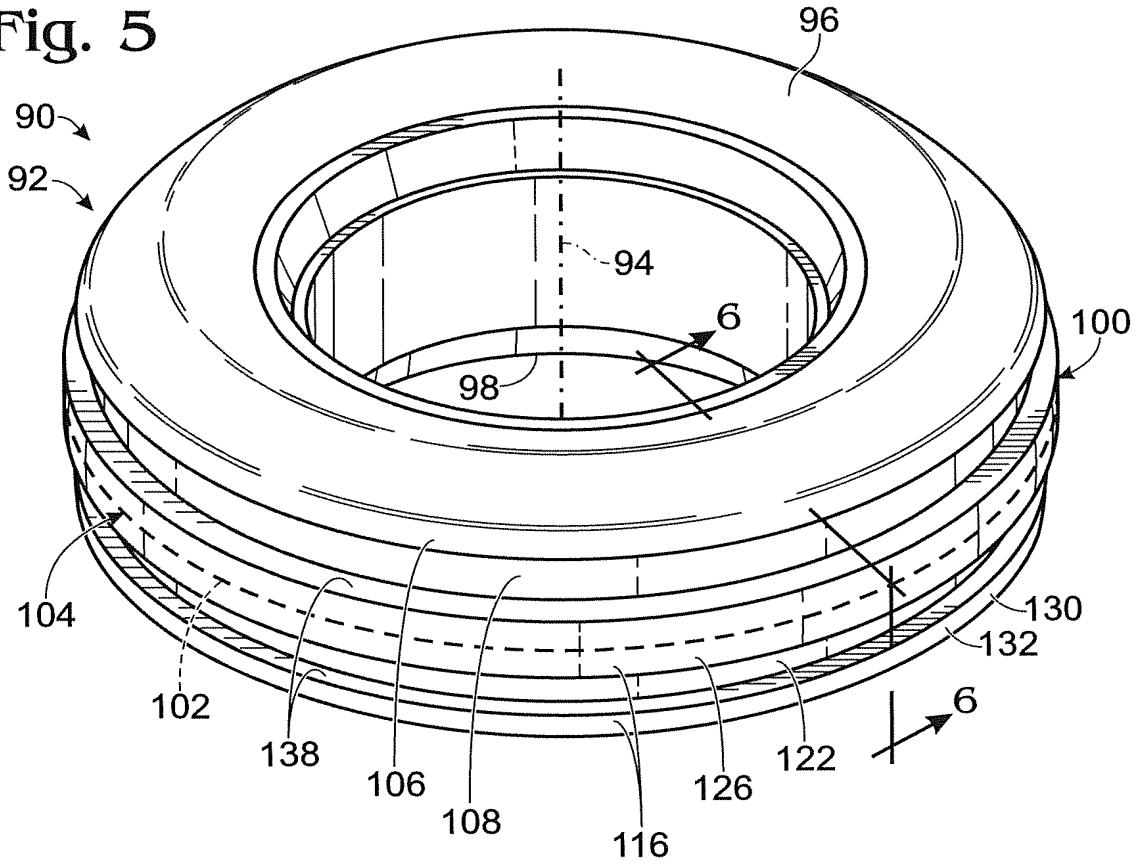
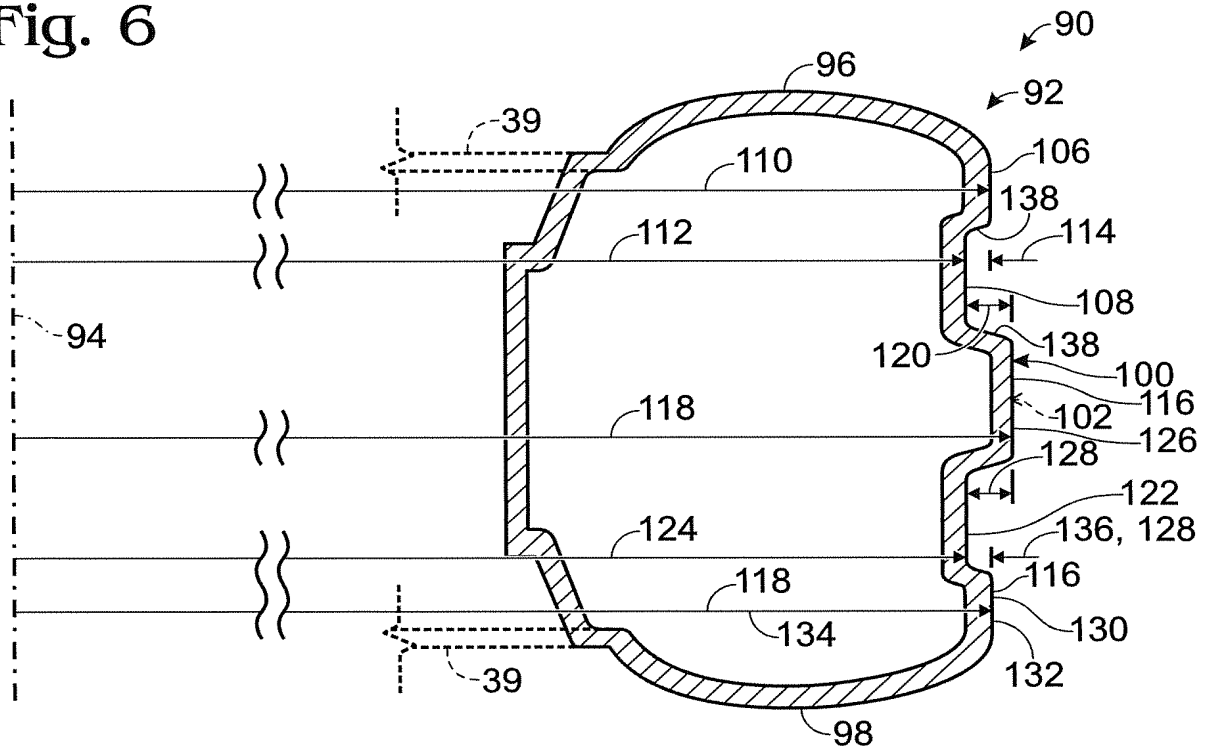

Fig. 6



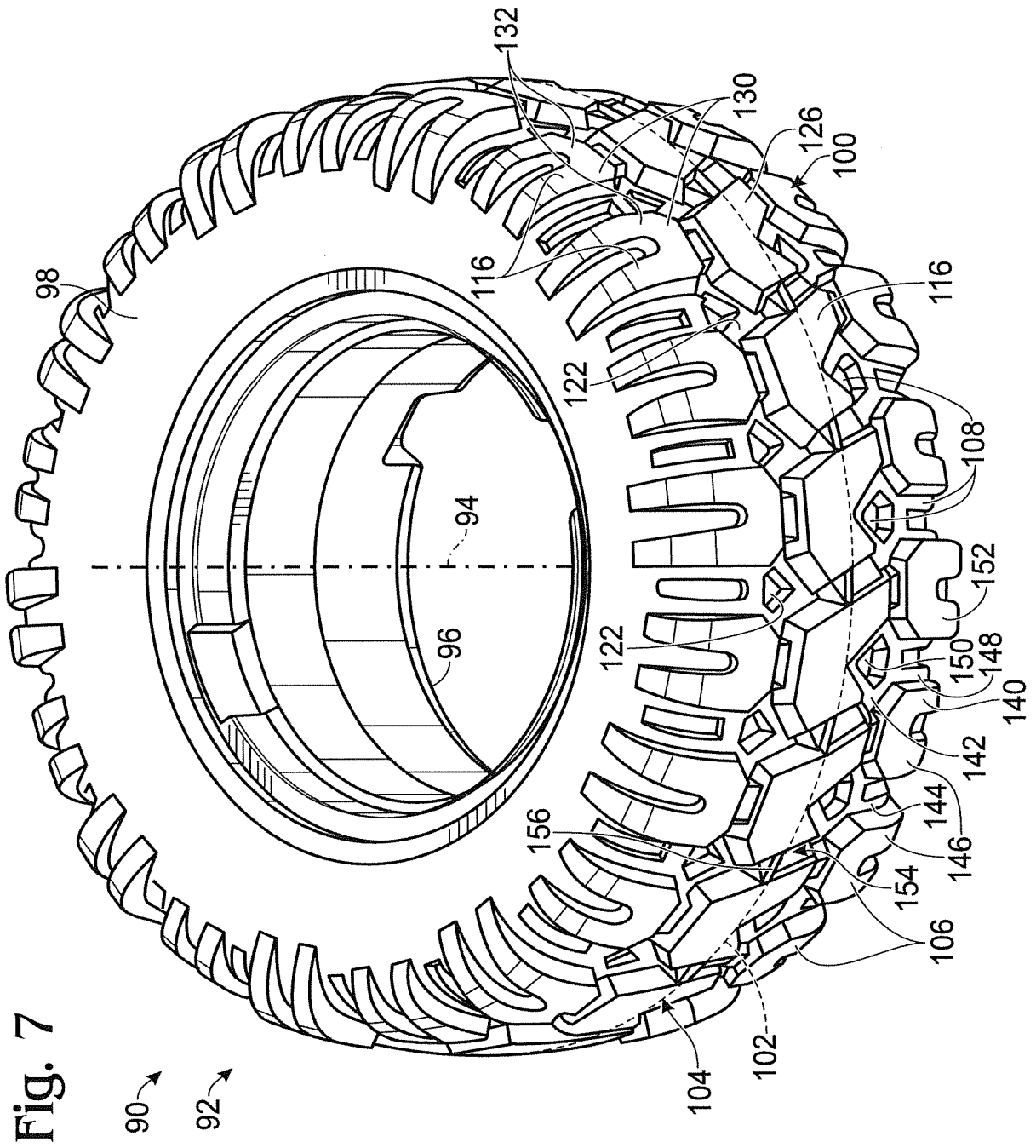

Fig. 7

Fig. 8

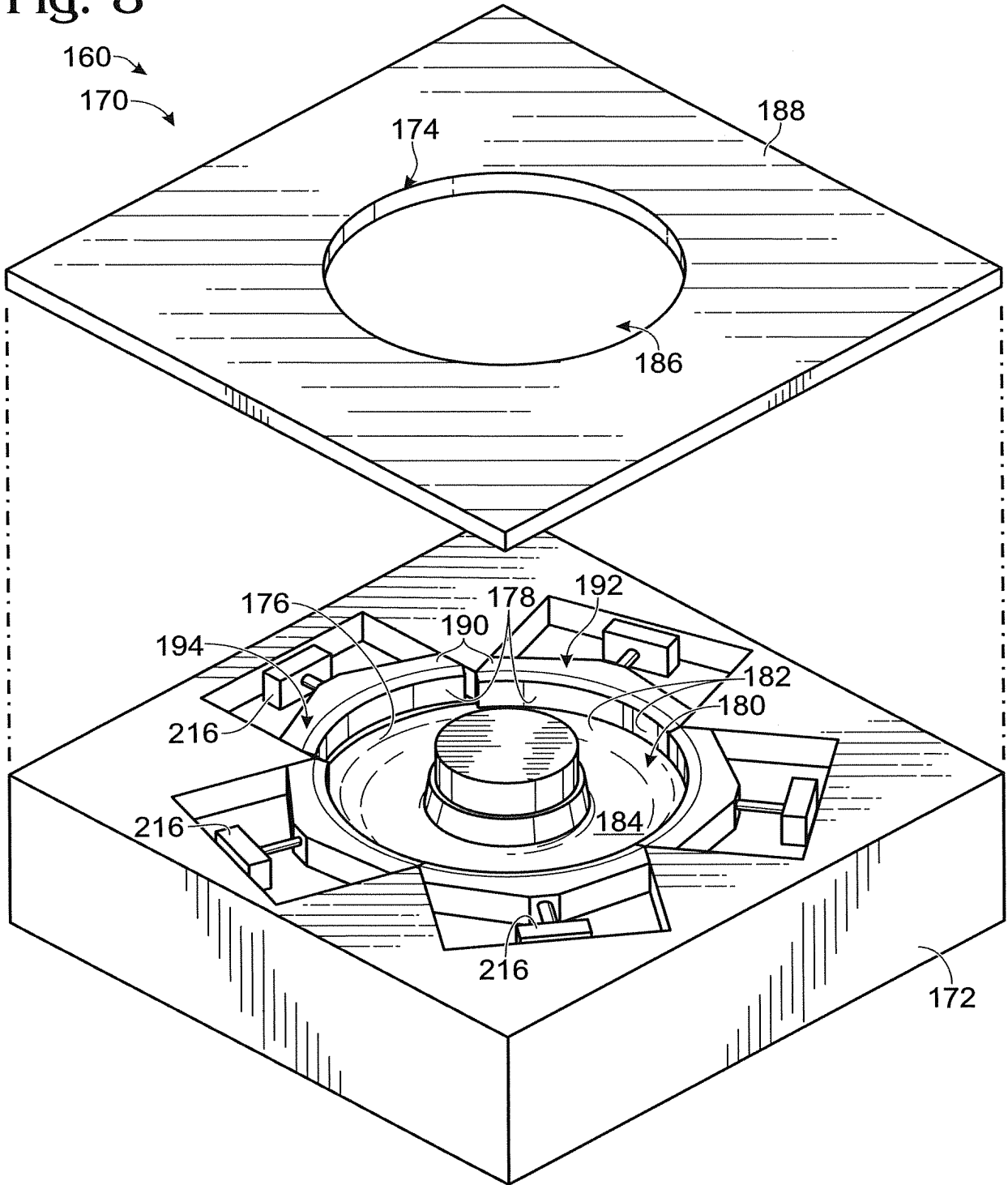

Fig. 9

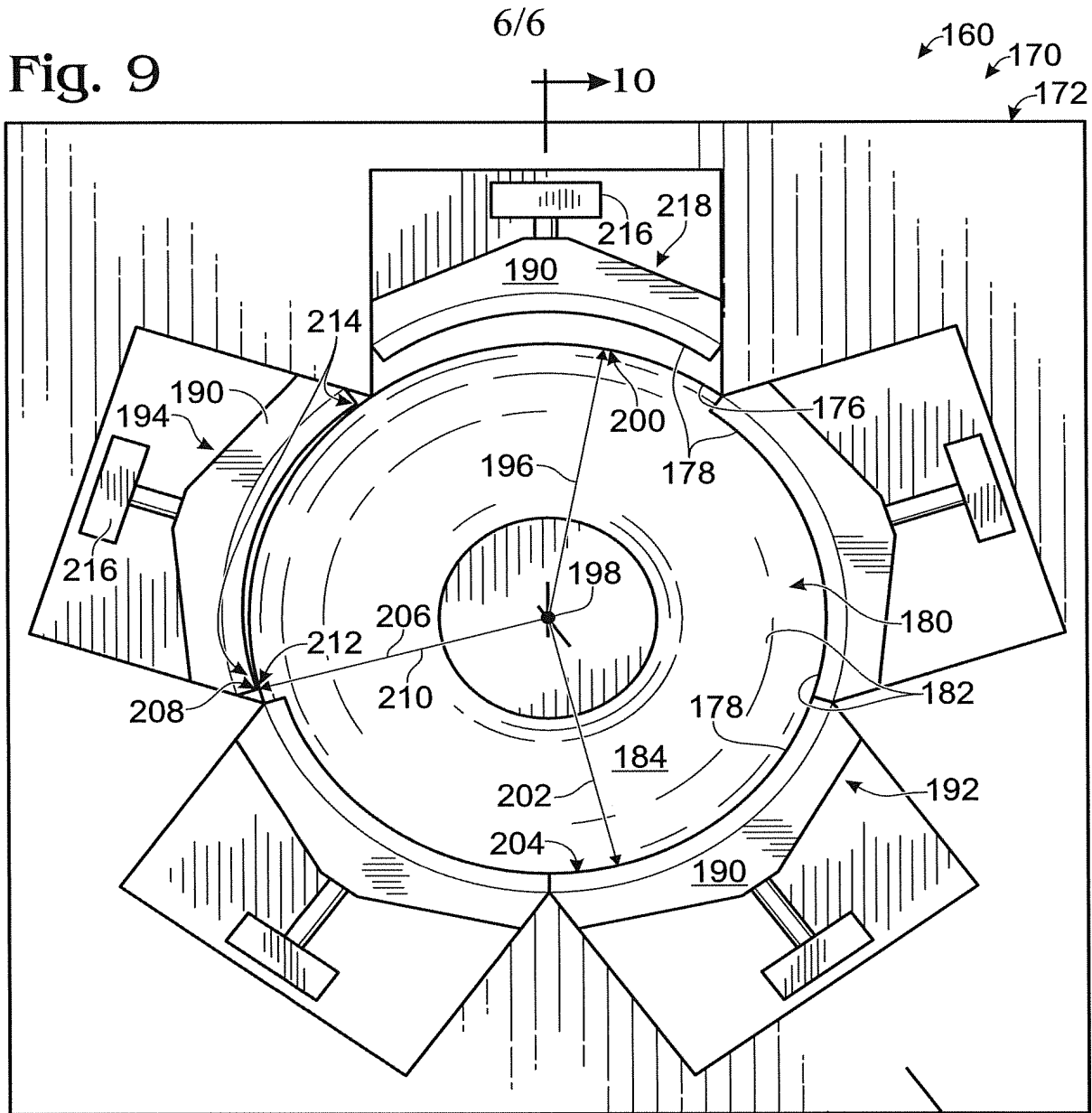
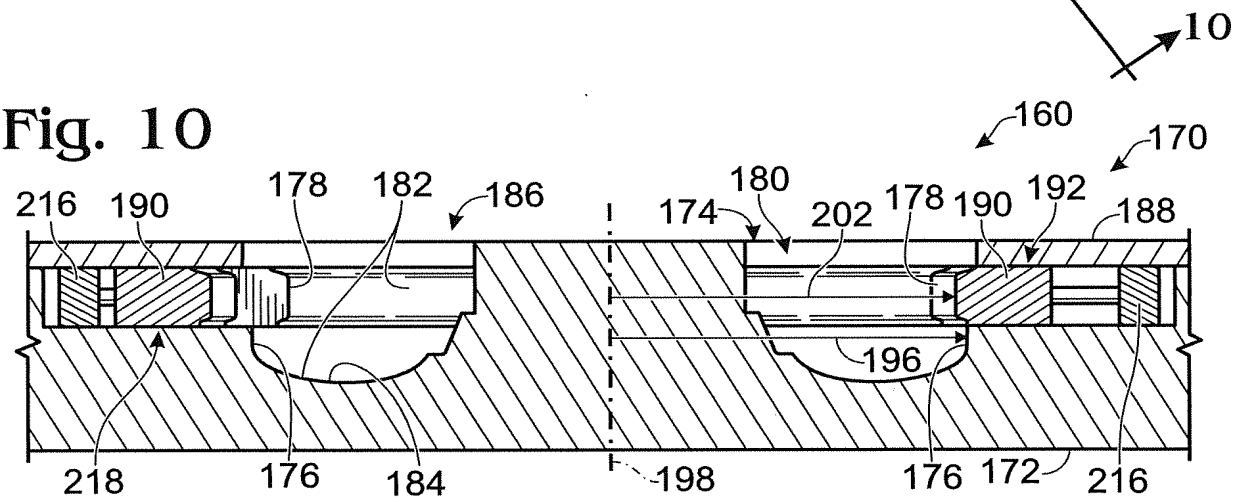

Fig. 10



IN THE UNITED STATES PATENT AND TRADEMARK OFFICE

Date: May 9, 2011

In re Application of:

ALBERT L. ARENDT, JAMES R. CARDUCCI, and CHRISTOPHER F. LUCAS

Serial No. : Not yet assigned

Filed : May 9, 2011

For : BLOW-MOLDED WHEELS HAVING UNDERCUT TREADS,
METHODS FOR PRODUCING THE SAME, AND CHILDREN'S
RIDE-ON VEHICLES INCLUDING THE SAME

Commissioner for Patents
PO Box 1450
Alexandria, Virginia 22313-1450

INFORMATION DISCLOSURE STATEMENT
UNDER 37 C.F.R. §§ 1.56, 1.97, and 1.98

Applicants are submitting this Information Disclosure Statement pursuant to 37 C.F.R. §§ 1.56, 1.97, and 1.98 to disclose to the U.S. Patent and Trademark Office the patents, publications, applications, and/or other references listed on the enclosed, completed PTO-1449 forms. The filing of this Information Disclosure Statement should not be construed as a representation that a search has been made or as an admission that the listed references are prior art for this application. Applicants respectfully request that the listed references be expressly considered during prosecution of the application, and that the references be made of record therein and appear among the "references cited" on any patents issuing therefrom.

CONTENT OF DISCLOSURE

This Information Disclosure Statement includes six (6) pages of PTO-1449 forms; however, it does not include copies of the references listed on the forms, as permitted under

37 C.F.R. § 1.98(d), because copies already were provided in an earlier U.S. application (Serial No. 12/577,565), or a priority application thereto, that is relied upon here for an earlier effective filing date under 35 U.S.C. § 120.

FOREIGN LANGUAGE REFERENCES

For each foreign document for which there is no English translation, a concise statement of relevance or an English language abstract is already of record in the previously cited patent application identified above.

TIMING OF DISCLOSURE / FEE INFORMATION

This Information Disclosure Statement is being filed with the application, or with a Request for Continued Examination of the application under 37 C.F.R. § 1.114. Therefore, in accordance with 37 C.F.R. § 1.97(b), no fee or statement under 37 C.F.R. § 1.97(e) is required.

Please contact the undersigned with any questions or comments regarding this Information Disclosure Statement.

Respectfully submitted,

CERTIFICATE OF E-FILING

I hereby certify that this correspondence and the accompanying PTO-1449 forms are being transmitted electronically via the United States Patent and Trademark Office's EFS-Web System on May 9, 2011.



Ian D. Gates

DASCENZO INTELLECTUAL
PROPERTY LAW, P.C.



Ian D. Gates
Registration No. 51,722
Customer No. 78569
DASCENZO INTELLECTUAL
PROPERTY LAW, P.C.
522 S.W. 5th Ave, Suite 925
Portland, Oregon 97204
Telephone: (503) 224-7529
Facsimile: (503) 224-7329



UNITED STATES PATENT AND TRADEMARK OFFICE

UNITED STATES DEPARTMENT OF COMMERCE
United States Patent and Trademark Office
Address: COMMISSIONER FOR PATENTS
P.O. Box 1450
Alexandria, Virginia 22313-1450
www.uspto.gov

Table with 7 columns: APPLICATION NUMBER, FILING or 371(c) DATE, GRP ART UNIT, FIL FEE REC'D, ATTY,DOCKET,NO, TOT CLAIMS, IND CLAIMS. Row 1: 13/103,310, 05/09/2011, 1742, 1090, MPW 3M1B, 20, 2

CONFIRMATION NO. 9050

78569
Dascenzo Intellectual Property Law, P.C.
522 SW 5th Ave
Suite 925
Portland, OR 97204-2126

FILING RECEIPT



Date Mailed: 05/24/2011

Receipt is acknowledged of this non-provisional patent application. The application will be taken up for examination in due course. Applicant will be notified as to the results of the examination. Any correspondence concerning the application must include the following identification information: the U.S. APPLICATION NUMBER, FILING DATE, NAME OF APPLICANT, and TITLE OF INVENTION. Fees transmitted by check or draft are subject to collection. Please verify the accuracy of the data presented on this receipt. If an error is noted on this Filing Receipt, please submit a written request for a Filing Receipt Correction. Please provide a copy of this Filing Receipt with the changes noted thereon. If you received a "Notice to File Missing Parts" for this application, please submit any corrections to this Filing Receipt with your reply to the Notice. When the USPTO processes the reply to the Notice, the USPTO will generate another Filing Receipt incorporating the requested corrections

Applicant(s)

Albert L. Arendt, West Seneca, NY;
James R. Carducci, East Aurora, NY;
Christopher F. Lucas, Cheektowaga, NY;

Assignment For Published Patent Application

Mattel, Inc., El Segundo, CA

Power of Attorney: None

Domestic Priority data as claimed by applicant

This application is a CON of 12/577,565 10/12/2009 PAT 7,939,008
which is a DIV of 11/509,421 08/23/2006 PAT 7,621,543

Foreign Applications (You may be eligible to benefit from the Patent Prosecution Highway program at the USPTO. Please see http://www.uspto.gov for more information.)

If Required, Foreign Filing License Granted: 05/19/2011

The country code and number of your priority application, to be used for filing abroad under the Paris Convention, is US 13/103,310

Projected Publication Date: To Be Determined - pending completion of Missing Parts

Non-Publication Request: No

Early Publication Request: No

Title

BLOW-MOLDED WHEELS HAVING UNDERCUT TREADS, METHODS FOR PRODUCING THE SAME, AND CHILDREN'S RIDE-ON VEHICLES INCLUDING THE SAME

Preliminary Class

264

PROTECTING YOUR INVENTION OUTSIDE THE UNITED STATES

Since the rights granted by a U.S. patent extend only throughout the territory of the United States and have no effect in a foreign country, an inventor who wishes patent protection in another country must apply for a patent in a specific country or in regional patent offices. Applicants may wish to consider the filing of an international application under the Patent Cooperation Treaty (PCT). An international (PCT) application generally has the same effect as a regular national patent application in each PCT-member country. The PCT process **simplifies** the filing of patent applications on the same invention in member countries, but **does not result** in a grant of "an international patent" and does not eliminate the need of applicants to file additional documents and fees in countries where patent protection is desired.

Almost every country has its own patent law, and a person desiring a patent in a particular country must make an application for patent in that country in accordance with its particular laws. Since the laws of many countries differ in various respects from the patent law of the United States, applicants are advised to seek guidance from specific foreign countries to ensure that patent rights are not lost prematurely.

Applicants also are advised that in the case of inventions made in the United States, the Director of the USPTO must issue a license before applicants can apply for a patent in a foreign country. The filing of a U.S. patent application serves as a request for a foreign filing license. The application's filing receipt contains further information and guidance as to the status of applicant's license for foreign filing.

Applicants may wish to consult the USPTO booklet, "General Information Concerning Patents" (specifically, the section entitled "Treaties and Foreign Patents") for more information on timeframes and deadlines for filing foreign patent applications. The guide is available either by contacting the USPTO Contact Center at 800-786-9199, or it can be viewed on the USPTO website at <http://www.uspto.gov/web/offices/pac/doc/general/index.html>.

For information on preventing theft of your intellectual property (patents, trademarks and copyrights), you may wish to consult the U.S. Government website, <http://www.stopfakes.gov>. Part of a Department of Commerce initiative, this website includes self-help "toolkits" giving innovators guidance on how to protect intellectual property in specific countries such as China, Korea and Mexico. For questions regarding patent enforcement issues, applicants may call the U.S. Government hotline at 1-866-999-HALT (1-866-999-4158).

LICENSE FOR FOREIGN FILING UNDER**Title 35, United States Code, Section 184****Title 37, Code of Federal Regulations, 5.11 & 5.15****GRANTED**

The applicant has been granted a license under 35 U.S.C. 184, if the phrase "IF REQUIRED, FOREIGN FILING LICENSE GRANTED" followed by a date appears on this form. Such licenses are issued in all applications where

the conditions for issuance of a license have been met, regardless of whether or not a license may be required as set forth in 37 CFR 5.15. The scope and limitations of this license are set forth in 37 CFR 5.15(a) unless an earlier license has been issued under 37 CFR 5.15(b). The license is subject to revocation upon written notification. The date indicated is the effective date of the license, unless an earlier license of similar scope has been granted under 37 CFR 5.13 or 5.14.

This license is to be retained by the licensee and may be used at any time on or after the effective date thereof unless it is revoked. This license is automatically transferred to any related applications(s) filed under 37 CFR 1.53(d). This license is not retroactive.

The grant of a license does not in any way lessen the responsibility of a licensee for the security of the subject matter as imposed by any Government contract or the provisions of existing laws relating to espionage and the national security or the export of technical data. Licensees should apprise themselves of current regulations especially with respect to certain countries, of other agencies, particularly the Office of Defense Trade Controls, Department of State (with respect to Arms, Munitions and Implements of War (22 CFR 121-128)); the Bureau of Industry and Security, Department of Commerce (15 CFR parts 730-774); the Office of Foreign Assets Control, Department of Treasury (31 CFR Parts 500+) and the Department of Energy.

NOT GRANTED

No license under 35 U.S.C. 184 has been granted at this time, if the phrase "IF REQUIRED, FOREIGN FILING LICENSE GRANTED" DOES NOT appear on this form. Applicant may still petition for a license under 37 CFR 5.12, if a license is desired before the expiration of 6 months from the filing date of the application. If 6 months has lapsed from the filing date of this application and the licensee has not received any indication of a secrecy order under 35 U.S.C. 181, the licensee may foreign file the application pursuant to 37 CFR 5.15(b).

PATENT APPLICATION FEE DETERMINATION RECORD

Substitute for Form PTO-875

Application or Docket Number
13/103,310

APPLICATION AS FILED - PART I

(Column 1) (Column 2)

FOR	NUMBER FILED	NUMBER EXTRA
BASIC FEE (37 CFR 1.16(a), (b), or (c))	N/A	N/A
SEARCH FEE (37 CFR 1.16(k), (l), or (m))	N/A	N/A
EXAMINATION FEE (37 CFR 1.16(o), (p), or (q))	N/A	N/A
TOTAL CLAIMS (37 CFR 1.16(j))	20	minus 20 = *
INDEPENDENT CLAIMS (37 CFR 1.16(h))	2	minus 3 = *
APPLICATION SIZE FEE (37 CFR 1.16(s))	If the specification and drawings exceed 100 sheets of paper, the application size fee due is \$270 (\$135 for small entity) for each additional 50 sheets or fraction thereof. See 35 U.S.C. 41(a)(1)(G) and 37 CFR 1.16(s).	
MULTIPLE DEPENDENT CLAIM PRESENT (37 CFR 1.16(j))		

SMALL ENTITY

RATE(\$)	FEE(\$)
N/A	
N/A	
N/A	
TOTAL	

OR OTHER THAN SMALL ENTITY

RATE(\$)	FEE(\$)
N/A	330
N/A	540
N/A	220
x 52 =	0.00
x 220 =	0.00
	0.00
	0.00
TOTAL	1090

* If the difference in column 1 is less than zero, enter "0" in column 2.

APPLICATION AS AMENDED - PART II

(Column 1) (Column 2) (Column 3)

AMENDMENT A		CLAIMS REMAINING AFTER AMENDMENT		HIGHEST NUMBER PREVIOUSLY PAID FOR	PRESENT EXTRA
	Total (37 CFR 1.16(j))	*	Minus	**	=
Independent (37 CFR 1.16(h))	*	Minus	***	=	
Application Size Fee (37 CFR 1.16(s))					
FIRST PRESENTATION OF MULTIPLE DEPENDENT CLAIM (37 CFR 1.16(j))					

SMALL ENTITY

RATE(\$)	ADDITIONAL FEE(\$)
x =	
x =	
TOTAL ADD'L FEE	

OR OTHER THAN SMALL ENTITY

RATE(\$)	ADDITIONAL FEE(\$)
x =	
x =	
TOTAL ADD'L FEE	

(Column 1) (Column 2) (Column 3)

AMENDMENT B		CLAIMS REMAINING AFTER AMENDMENT		HIGHEST NUMBER PREVIOUSLY PAID FOR	PRESENT EXTRA
	Total (37 CFR 1.16(j))	*	Minus	**	=
Independent (37 CFR 1.16(h))	*	Minus	***	=	
Application Size Fee (37 CFR 1.16(s))					
FIRST PRESENTATION OF MULTIPLE DEPENDENT CLAIM (37 CFR 1.16(j))					

SMALL ENTITY

RATE(\$)	ADDITIONAL FEE(\$)
x =	
x =	
TOTAL ADD'L FEE	

OR OTHER THAN SMALL ENTITY

RATE(\$)	ADDITIONAL FEE(\$)
x =	
x =	
TOTAL ADD'L FEE	

* If the entry in column 1 is less than the entry in column 2, write "0" in column 3.

** If the "Highest Number Previously Paid For" IN THIS SPACE is less than 20, enter "20".

*** If the "Highest Number Previously Paid For" IN THIS SPACE is less than 3, enter "3".

The "Highest Number Previously Paid For" (Total or Independent) is the highest found in the appropriate box in column 1.



UNITED STATES PATENT AND TRADEMARK OFFICE

UNITED STATES DEPARTMENT OF COMMERCE
United States Patent and Trademark Office
Address: COMMISSIONER FOR PATENTS
P.O. Box 1450
Alexandria, Virginia 22313-1450
www.uspto.gov

Table with 4 columns: APPLICATION NUMBER (13/103,310), FILING OR 371(C) DATE (05/09/2011), FIRST NAMED APPLICANT (Albert L. Arendt), ATTY. DOCKET NO./TITLE (MPW 3M1B)

CONFIRMATION NO. 9050

FORMALITIES LETTER



78569
Dascenzo Intellectual Property Law, P.C.
522 SW 5th Ave
Suite 925
Portland, OR 97204-2126

Date Mailed: 05/24/2011

NOTICE TO FILE MISSING PARTS OF NONPROVISIONAL APPLICATION

FILED UNDER 37 CFR 1.53(b)

Filing Date Granted

Items Required To Avoid Abandonment:

An application number and filing date have been accorded to this application. The item(s) indicated below, however, are missing. Applicant is given TWO MONTHS from the date of this Notice within which to file all required items below to avoid abandonment. Extensions of time may be obtained by filing a petition accompanied by the extension fee under the provisions of 37 CFR 1.136(a).

- The oath or declaration is missing.
A properly signed oath or declaration in compliance with 37 CFR 1.63, identifying the application by the above Application Number and Filing Date, is required.
Note: If a petition under 37 CFR 1.47 is being filed, an oath or declaration in compliance with 37 CFR 1.63 signed by all available joint inventors, or if no inventor is available by a party with sufficient proprietary interest, is required.

The applicant needs to satisfy supplemental fees problems indicated below.

The required item(s) identified below must be timely submitted to avoid abandonment:

- A surcharge (for late submission of filing fee, search fee, examination fee or oath or declaration) as set forth in 37 CFR 1.16(f) of \$130 for a non-small entity, must be submitted.

SUMMARY OF FEES DUE:

Total fee(s) required within TWO MONTHS from the date of this Notice is \$130 for a non-small entity

- \$130 Surcharge.

Replies should be mailed to:

Mail Stop Missing Parts
Commissioner for Patents
P.O. Box 1450
Alexandria VA 22313-1450

Registered users of EFS-Web may alternatively submit their reply to this notice via EFS-Web.
<https://sportal.uspto.gov/authenticate/AuthenticateUserLocalEPF.html>

For more information about EFS-Web please call the USPTO Electronic Business Center at **1-866-217-9197** or visit our website at <http://www.uspto.gov/ebc>.

If you are not using EFS-Web to submit your reply, you must include a copy of this notice.

/tnegash/

Office of Data Management, Application Assistance Unit (571) 272-4000, or (571) 272-4200, or 1-888-786-0101

IN THE UNITED STATES PATENT AND TRADEMARK OFFICE

May 27, 2011

In re Application of:

ALBERT L. ARENDT, JAMES R. CARDUCCI, and CHRISTOPHER F. LUCAS

Serial No. : 13/103,310 Group Art Unit: 1742
Filed : May 9, 2011
For : BLOW-MOLDED WHEELS HAVING UNDERCUT TREADS,
METHODS FOR PRODUCING THE SAME, AND CHILDREN'S
RIDE-ON VEHICLES INCLUDING THE SAME

Mail Stop Missing Parts

Commissioner for Patents

PO Box 1450

Alexandria, Virginia 22313-1450

**RESPONSE TO NOTICE TO FILE MISSING PARTS
OF NONPROVISIONAL APPLICATION**

In response to the Notice to File Missing Parts of Nonprovisional Application dated May 24, 2011, enclosed for filing in connection with the above-identified patent application is a Power of Attorney and a Declaration for Patent Application. These documents and our payment in the amount of \$130.00 for payment of the missing parts surcharge are being submitted via the EFS-Web. Because this response is being submitted via the EFS-Web, no copy of the Notice to File Missing Parts of Nonprovisional Application is enclosed.

Respectfully submitted,

DASCENZO INTELLECTUAL
PROPERTY LAW, P.C.



David S. D'Ascenzo
Registration No. 39,952
Customer No. 78569
DASCENZO INTELLECTUAL
PROPERTY LAW, P.C.
522 S.W. 5th Avenue, Suite 925
Portland, Oregon 97204
Telephone: (503) 224-7529
Facsimile: (503) 224-7329

CERTIFICATE OF E-FILING

I hereby certify that this correspondence and the attached Power of Attorney and Declaration for Patent Application are being e-filed with the U.S. Patent and Trademark Office via the EFS-Web on May 27, 2011.



David S. D'Ascenzo

DECLARATION FOR PATENT APPLICATION
English Language Declaration

As a below-named inventor, I hereby declare that:

My residence, mailing address, and citizenship are as stated below next to my name.

I believe that I am the original, first, and sole inventor (if only one name is listed below) or an original, first, and joint inventor (if plural names are listed below) of the subject matter that is claimed and for which a patent is sought on the invention entitled:

**BLOW-MOLDED WHEELS HAVING UNDERCUT TREADS,
METHODS FOR PRODUCING THE SAME, AND
CHILDREN'S RIDE-ON VEHICLES INCLUDING THE SAME**

the specification of which

 X is attached hereto, or
_____ was filed on _____ as U.S. Patent Application Serial No. _____.

I hereby state that I have reviewed and understand the contents of the above-identified specification, including the claim(s), as amended by any amendment referred to above.

I acknowledge the duty to disclose information that is material to patentability as defined in 37 C.F.R. § 1.56, including, for continuation-in-part applications, material information that became available between the filing date of the prior application and the national or PCT international filing date of the continuation-in-part application.

I hereby claim foreign priority benefits under 35 U.S.C. § 119(a)-(d) or (f) or 365(b) of any foreign application(s) for patent, inventor's or plant breeder's rights certificate(s), or 365(a) of any PCT international application that designated at least one country other than the United States of America, listed below, and also have identified below any foreign application for patent, inventor's or plant breeder's rights certificate(s), or any PCT international application having a filing date before that of the application on which priority is claimed.

Prior Foreign Application Number(s)	Country	Foreign Filing Date (MM/DD/YYYY)	Priority Claimed?	Certified Copy Attached?

DIRECT COMMUNICATIONS TO:

David S. D'Ascenzo
DASCENZO INTELLECTUAL
PROPERTY LAW, P.C.
522 S.W. 5th Avenue, Suite 925
Portland, Oregon 97204

Telephone: (503) 224-7529
Facsimile: (503) 224-7329
Email: david@dascenzoiplaw.com

I hereby declare that all statements made herein of my own knowledge are true and that all statements made on information and belief are believed to be true; and further that these statements were made with the knowledge that willful false statements and the like so made are punishable by fine or imprisonment, or both, under 18 U.S.C. § 1001, and that such willful false statements may jeopardize the validity of the application or any patent issuing thereon.

Full name of sole or first joint inventor: ALBERT L. ARENDT

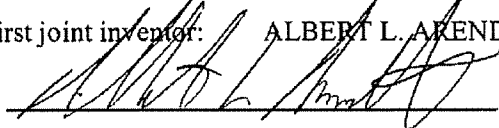
Inventor's signature:  Date: 4/19/2011

Residence: 141 Willowdale Drive, West Seneca, New York 14224
Citizenship: United States of America
Post Office Address: 141 Willowdale Drive, West Seneca, New York 14224

Full name of second joint inventor: JAMES R. CARDUCCI

Inventor's signature:  Date: 5/16/2011

Residence: 129 Maple Street, East Aurora, New York 14052
Citizenship: United States of America
Post Office Address: 129 Maple Street, East Aurora, New York 14052

Full name of third joint inventor: CHRISTOPHER F. LUCAS

Inventor's signature:  Date: 4-19-11

Residence: 38 Monterey Lane, Cheektowaga, New York 14225
Citizenship: United States of America
Post Office Address: 38 Monterey Lane, Cheektowaga, New York 14225

**POWER OF ATTORNEY,
STATEMENT UNDER 37 C.F.R. § 3.73(b), and
ASSERTION OF RIGHT UNDER 37 C.F.R. § 3.71 AND MPEP § 106**

Applicants: Albert L. Arendt, James R. Carducci, and Christopher F. Lucas
Serial No.: _____
Filed: _____
Title: BLOW-MOLDED WHEELS HAVING UNDERCUT TREADS. METHODS FOR
PRODUCING THE SAME. AND CHILDREN'S RIDE-ON VEHICLES INCLUDING
THE SAME

Mattel, Inc., a Delaware corporation, hereby appoints the practitioners at DASCENZO INTELLECTUAL PROPERTY LAW, P.C., USPTO Customer No. 78569, as its attorneys and agents to prosecute the above-identified patent application and to transact all business in the United States Patent and Trademark Office connected therewith. These practitioners currently include:

David S. D'Ascenzo, Reg. No. 39,952; Ian D. Gates, Reg. No. 51,722;
Timothy M. Whalen, Reg. No. 58,467; and Larry E. Bailey, Jr., Reg. No. 66,043.

Mattel, Inc. states, under 37 C.F.R. § 3.73(b), that it is the assignee of the entire right, title, and interest in the above-identified patent application by virtue of an assignment from each of the inventor(s) named in the above-identified patent application. Copies of assignments or other documents in the chain of title are attached.

Mattel, Inc. hereby asserts its right, under 37 C.F.R. § 3.71 and MPEP § 106, to conduct the prosecution of the above-identified patent application to the exclusion of the named inventor(s) and any previous assignee(s).

DIRECT COMMUNICATIONS TO:

David S. D'Ascenzo
DASCENZO INTELLECTUAL
PROPERTY LAW, P.C.
522 S.W. 5th Avenue, Suite 925
Portland, Oregon 97204

Telephone: (503) 224-7529
Facsimile: (503) 224-7329
Email: david@dascenzoiplaw.com

The undersigned (whose title is supplied below) is authorized to act on behalf of the above-identified assignee.

I hereby declare that all statements made herein of my own knowledge are true and that all statements made on information and belief are believed to be true; and further that these statements are made with the knowledge that willful false statements and the like so made are punishable by fine or imprisonment, or both, under 18 U.S.C. § 1001, and that such willful false statements may jeopardize the validity of the application or any patent issuing thereon.

MATTEL, INC.

Date: 5-16-2011

By: 
Dennis M. Wesolowski, Assistant Secretary

ASSIGNMENT

WHEREAS, we, Albert L. Arendt, of West Seneca, County of Erie, State of New York, James R. Carducci, of East Aurora, County of Erie, State of New York, and Christopher F. Lucas, of Cheektowaga, County of Erie, State of New York, have invented certain improvements in BLOW-MOLDED WHEELS HAVING UNDERCUT TREADS, METHODS FOR PRODUCING THE SAME, AND CHILDREN'S RIDE-ON VEHICLES INCLUDING THE SAME, for which we have executed an application for Letters Patent of the United States on the date we executed this Assignment as hereinafter set forth; and

WHEREAS, Mattel, Inc., a Delaware corporation, having its principal place of business in El Segundo, County of Los Angeles, State of California, is desirous of acquiring an interest therein;

NOW, THEREFORE, for good and valuable consideration, the receipt and sufficiency of which hereby are acknowledged, we, Albert L. Arendt, James R. Carducci, and Christopher F. Lucas, have sold, assigned and transferred, and by these presents do sell, assign and transfer unto Mattel, Inc. the full and exclusive right to the said invention in the United States and its territorial possessions and in any and all foreign countries and the entire right, title and interest in and to any and all Letters Patent which may be granted therefor in the United States and its territorial possessions and in any and all foreign countries and in and to any and all related U.S. and foreign patent applications, including PCT patent applications, divisionals, reissues, continuations and extensions thereof.

We hereby authorize and request the Patent Office officials in the United States and any and all foreign countries to issue any and all of said Letters Patent, when granted, to

Mattel, Inc., as the assignee of our entire right, title and interest in and to the same, for the sole use of Mattel, Inc., its successors and assigns.

Further, we hereby acknowledge and agree that at the time of execution of this assignment, we have good and full right and lawful authority to execute this assignment and to convey the above-indicated rights to Mattel, Inc., its successors and assigns.

Further, we agree that we will communicate to the said Mattel, Inc. or its representatives any facts known to us respecting said invention, and testify in any legal proceeding, sign all lawful papers, execute all related, divisional, continuation, substitution, renewal, reissue, PCT, and foreign applications, execute all necessary assignment papers to cause any and all of said Letters Patent to be issued to Mattel, Inc., make all rightful oaths and generally do everything possible to aid Mattel, Inc., its successors and assigns, to obtain and enforce proper protection for said invention in the United States and in any and all foreign countries.

IN TESTIMONY WHEREOF, I have hereunto set my hand.

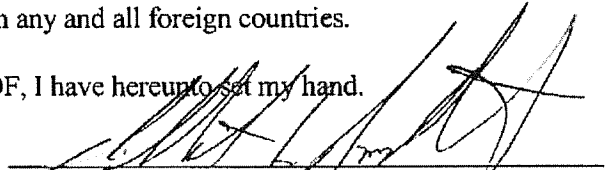
ALBERT L. ARENDT

Date: 4/19/2011

Witness:

Vicki E. Hoffman
(Printed Name)

Vicki E. Hoffman
(Signature)

8126 Hunters Creek Rd
(Address)

Holland, NY
(City, State)

IN TESTIMONY WHEREOF, I have hereunto set my hand.

James R. Carducci
JAMES R. CARDUCCI

Date: 5/16/2011

Witness:

Vicki E. Hoffman
(Printed Name)

Vicki E. Hoffman
(Signature)

8126 Hunter's Creek Road
(Address)

Holland, NY
(City, State)

IN TESTIMONY WHEREOF, I have hereunto set my hand.

Christopher F. Lucas
CHRISTOPHER F. LUCAS

Date: 4-19-11

Witness:

Vicki E. Hoffman
(Printed Name)

Vicki E. Hoffman
(Signature)

8126 Hunter's Creek Rd
(Address)

Holland, NY
(City, State)

Electronic Patent Application Fee Transmittal

Application Number:	13103310
Filing Date:	09-May-2011
Title of Invention:	BLOW-MOLDED WHEELS HAVING UNDERCUT TREADS, METHODS FOR PRODUCING THE SAME, AND CHILDREN'S RIDE-ON VEHICLES INCLUDING THE SAME
First Named Inventor/Applicant Name:	Albert L. Arendt
Filer:	David S. D'Ascenzo/Robin Davin
Attorney Docket Number:	MPW 3M1B

Filed as Large Entity

Utility under 35 USC 111(a) Filing Fees

Description	Fee Code	Quantity	Amount	Sub-Total in USD(\$)
Basic Filing:				
Pages:				
Claims:				
Miscellaneous-Filing:				
Late filing fee for oath or declaration	1051	1	130	130

Petition:

Patent-Appeals-and-Interference:

Post-Allowance-and-Post-Issuance:

Extension-of-Time:

Description	Fee Code	Quantity	Amount	Sub-Total in USD(\$)
Miscellaneous:				
Total in USD (\$)				130

Electronic Acknowledgement Receipt

EFS ID:	10183211
Application Number:	13103310
International Application Number:	
Confirmation Number:	9050
Title of Invention:	BLOW-MOLDED WHEELS HAVING UNDERCUT TREADS, METHODS FOR PRODUCING THE SAME, AND CHILDREN'S RIDE-ON VEHICLES INCLUDING THE SAME
First Named Inventor/Applicant Name:	Albert L. Arendt
Customer Number:	78569
Filer:	David S. D'Ascenzo/Robin Davin
Filer Authorized By:	David S. D'Ascenzo
Attorney Docket Number:	MPW 3M1B
Receipt Date:	27-MAY-2011
Filing Date:	09-MAY-2011
Time Stamp:	12:19:13
Application Type:	Utility under 35 USC 111(a)

Payment information:

Submitted with Payment	yes
Payment Type	Deposit Account
Payment was successfully received in RAM	\$130
RAM confirmation Number	10271
Deposit Account	504551
Authorized User	

The Director of the USPTO is hereby authorized to charge indicated fees and credit any overpayment as follows:

Charge any Additional Fees required under 37 C.F.R. Section 1.16 (National application filing, search, and examination fees)

Charge any Additional Fees required under 37 C.F.R. Section 1.17 (Patent application and reexamination processing fees)

Charge any Additional Fees required under 37 C.F.R. Section 1.21 (Miscellaneous fees and charges)

File Listing:

Document Number	Document Description	File Name	File Size(Bytes)/ Message Digest	Multi Part /.zip	Pages (if appl.)
1	Applicant Response to Pre-Exam Formalities Notice	Response_to_Notice_to_File_Missing_Parts_MPW3M1B_5-27-11.pdf	29159 d41d1ae0c8d1a16ee6afa906afcc0e1609f3b1ef	no	1
Warnings:					
Information:					
2	Oath or Declaration filed	Declaration_for_Patent_Application_MPW3M1B_5-27-11.pdf	85506 3f88ead91afeb16c42efb655d1102d03180922f8	no	2
Warnings:					
Information:					
3		Power_of_Attorney_MPW3M1B_5-27-11.pdf	152026 818e9696ff333ac6d22f905450c0373b3371d464	yes	4
	Multipart Description/PDF files in .zip description				
	Document Description		Start	End	
	Power of Attorney		1	1	
	Assignee showing of ownership per 37 CFR 3.73(b).		2	4	
Warnings:					
Information:					
4	Fee Worksheet (PTO-875)	fee-info.pdf	30150 de58fc5679c74a846dcbdaef2ef6ba2953330c33	no	2
Warnings:					
Information:					
Total Files Size (in bytes):			296841		

This Acknowledgement Receipt evidences receipt on the noted date by the USPTO of the indicated documents, characterized by the applicant, and including page counts, where applicable. It serves as evidence of receipt similar to a Post Card, as described in MPEP 503.

New Applications Under 35 U.S.C. 111

If a new application is being filed and the application includes the necessary components for a filing date (see 37 CFR 1.53(b)-(d) and MPEP 506), a Filing Receipt (37 CFR 1.54) will be issued in due course and the date shown on this Acknowledgement Receipt will establish the filing date of the application.

National Stage of an International Application under 35 U.S.C. 371

If a timely submission to enter the national stage of an international application is compliant with the conditions of 35 U.S.C. 371 and other applicable requirements a Form PCT/DO/EO/903 indicating acceptance of the application as a national stage submission under 35 U.S.C. 371 will be issued in addition to the Filing Receipt, in due course.

New International Application Filed with the USPTO as a Receiving Office

If a new international application is being filed and the international application includes the necessary components for an international filing date (see PCT Article 11 and MPEP 1810), a Notification of the International Application Number and of the International Filing Date (Form PCT/RO/105) will be issued in due course, subject to prescriptions concerning national security, and the date shown on this Acknowledgement Receipt will establish the international filing date of the application.

Electronic Acknowledgement Receipt

EFS ID:	10183211
Application Number:	13103310
International Application Number:	
Confirmation Number:	9050
Title of Invention:	BLOW-MOLDED WHEELS HAVING UNDERCUT TREADS, METHODS FOR PRODUCING THE SAME, AND CHILDREN'S RIDE-ON VEHICLES INCLUDING THE SAME
First Named Inventor/Applicant Name:	Albert L. Arendt
Customer Number:	78569
Filer:	David S. D'Ascenzo/Robin Davin
Filer Authorized By:	David S. D'Ascenzo
Attorney Docket Number:	MPW 3M1B
Receipt Date:	27-MAY-2011
Filing Date:	09-MAY-2011
Time Stamp:	12:19:13
Application Type:	Utility under 35 USC 111(a)

Payment information:

Submitted with Payment	yes
Payment Type	Deposit Account
Payment was successfully received in RAM	\$130
RAM confirmation Number	10271
Deposit Account	504551
Authorized User	

The Director of the USPTO is hereby authorized to charge indicated fees and credit any overpayment as follows:

Charge any Additional Fees required under 37 C.F.R. Section 1.16 (National application filing, search, and examination fees)

Charge any Additional Fees required under 37 C.F.R. Section 1.17 (Patent application and reexamination processing fees)

Charge any Additional Fees required under 37 C.F.R. Section 1.21 (Miscellaneous fees and charges)

File Listing:

Document Number	Document Description	File Name	File Size(Bytes)/ Message Digest	Multi Part /.zip	Pages (if appl.)
1	Applicant Response to Pre-Exam Formalities Notice	Response_to_Notice_to_File_Missing_Parts_MPW3M1B_5-27-11.pdf	29159 d41d1ae0c8d1a16ee6afa906afcc0e1609f3b1ef	no	1
Warnings:					
Information:					
2	Oath or Declaration filed	Declaration_for_Patent_Application_MPW3M1B_5-27-11.pdf	85506 3f88ead91afeb16c42efb655d1102d03180922f8	no	2
Warnings:					
Information:					
3		Power_of_Attorney_MPW3M1B_5-27-11.pdf	152026 818e9696ff333ac6d22f905450c0373b3371d464	yes	4
	Multipart Description/PDF files in .zip description				
	Document Description		Start	End	
	Power of Attorney		1	1	
	Assignee showing of ownership per 37 CFR 3.73(b).		2	4	
Warnings:					
Information:					
4	Fee Worksheet (PTO-875)	fee-info.pdf	30150 de58fc5679c74a846dcbdae2ef6ba2953330c33	no	2
Warnings:					
Information:					
Total Files Size (in bytes):			296841		

This Acknowledgement Receipt evidences receipt on the noted date by the USPTO of the indicated documents, characterized by the applicant, and including page counts, where applicable. It serves as evidence of receipt similar to a Post Card, as described in MPEP 503.

New Applications Under 35 U.S.C. 111

If a new application is being filed and the application includes the necessary components for a filing date (see 37 CFR 1.53(b)-(d) and MPEP 506), a Filing Receipt (37 CFR 1.54) will be issued in due course and the date shown on this Acknowledgement Receipt will establish the filing date of the application.

National Stage of an International Application under 35 U.S.C. 371

If a timely submission to enter the national stage of an international application is compliant with the conditions of 35 U.S.C. 371 and other applicable requirements a Form PCT/DO/EO/903 indicating acceptance of the application as a national stage submission under 35 U.S.C. 371 will be issued in addition to the Filing Receipt, in due course.

New International Application Filed with the USPTO as a Receiving Office

If a new international application is being filed and the international application includes the necessary components for an international filing date (see PCT Article 11 and MPEP 1810), a Notification of the International Application Number and of the International Filing Date (Form PCT/RO/105) will be issued in due course, subject to prescriptions concerning national security, and the date shown on this Acknowledgement Receipt will establish the international filing date of the application.



UNITED STATES PATENT AND TRADEMARK OFFICE

UNITED STATES DEPARTMENT OF COMMERCE
United States Patent and Trademark Office
Address: COMMISSIONER FOR PATENTS
P.O. Box 1450
Alexandria, Virginia 22313-1450
www.uspto.gov

Table with 7 columns: APPLICATION NUMBER, FILING or 371(c) DATE, GRP ART UNIT, FIL FEE REC'D, ATTY,DOCKET,NO, TOT CLAIMS, IND CLAIMS. Row 1: 13/103,310, 05/09/2011, 1742, 1220, MPW 3M1B, 20, 2

CONFIRMATION NO. 9050

UPDATED FILING RECEIPT



David S. D'Ascenzo
DASCENZO INTELLECTUAL PROPERTY LAW, P.C.
Suite 925
522 S.W. 5th Avenue
Portland, OR 97204

Date Mailed: 06/06/2011

Receipt is acknowledged of this non-provisional patent application. The application will be taken up for examination in due course. Applicant will be notified as to the results of the examination. Any correspondence concerning the application must include the following identification information: the U.S. APPLICATION NUMBER, FILING DATE, NAME OF APPLICANT, and TITLE OF INVENTION. Fees transmitted by check or draft are subject to collection. Please verify the accuracy of the data presented on this receipt. If an error is noted on this Filing Receipt, please submit a written request for a Filing Receipt Correction. Please provide a copy of this Filing Receipt with the changes noted thereon. If you received a "Notice to File Missing Parts" for this application, please submit any corrections to this Filing Receipt with your reply to the Notice. When the USPTO processes the reply to the Notice, the USPTO will generate another Filing Receipt incorporating the requested corrections

Applicant(s)

Albert L. Arendt, West Seneca, NY;
James R. Carducci, East Aurora, NY;
Christopher F. Lucas, Cheektowaga, NY;

Assignment For Published Patent Application

Mattel, Inc., El Segundo, CA

Power of Attorney: The patent practitioners associated with Customer Number 78569

Domestic Priority data as claimed by applicant

This application is a CON of 12/577,565 10/12/2009 PAT 7,939,008
which is a DIV of 11/509,421 08/23/2006 PAT 7,621,543

Foreign Applications (You may be eligible to benefit from the Patent Prosecution Highway program at the USPTO. Please see http://www.uspto.gov for more information.)

If Required, Foreign Filing License Granted: 05/19/2011

The country code and number of your priority application, to be used for filing abroad under the Paris Convention, is US 13/103,310

Projected Publication Date: 09/15/2011

Non-Publication Request: No

Early Publication Request: No

Title

BLOW-MOLDED WHEELS HAVING UNDERCUT TREADS, METHODS FOR PRODUCING THE SAME, AND CHILDREN'S RIDE-ON VEHICLES INCLUDING THE SAME

Preliminary Class

264

PROTECTING YOUR INVENTION OUTSIDE THE UNITED STATES

Since the rights granted by a U.S. patent extend only throughout the territory of the United States and have no effect in a foreign country, an inventor who wishes patent protection in another country must apply for a patent in a specific country or in regional patent offices. Applicants may wish to consider the filing of an international application under the Patent Cooperation Treaty (PCT). An international (PCT) application generally has the same effect as a regular national patent application in each PCT-member country. The PCT process **simplifies** the filing of patent applications on the same invention in member countries, but **does not result** in a grant of "an international patent" and does not eliminate the need of applicants to file additional documents and fees in countries where patent protection is desired.

Almost every country has its own patent law, and a person desiring a patent in a particular country must make an application for patent in that country in accordance with its particular laws. Since the laws of many countries differ in various respects from the patent law of the United States, applicants are advised to seek guidance from specific foreign countries to ensure that patent rights are not lost prematurely.

Applicants also are advised that in the case of inventions made in the United States, the Director of the USPTO must issue a license before applicants can apply for a patent in a foreign country. The filing of a U.S. patent application serves as a request for a foreign filing license. The application's filing receipt contains further information and guidance as to the status of applicant's license for foreign filing.

Applicants may wish to consult the USPTO booklet, "General Information Concerning Patents" (specifically, the section entitled "Treaties and Foreign Patents") for more information on timeframes and deadlines for filing foreign patent applications. The guide is available either by contacting the USPTO Contact Center at 800-786-9199, or it can be viewed on the USPTO website at <http://www.uspto.gov/web/offices/pac/doc/general/index.html>.

For information on preventing theft of your intellectual property (patents, trademarks and copyrights), you may wish to consult the U.S. Government website, <http://www.stopfakes.gov>. Part of a Department of Commerce initiative, this website includes self-help "toolkits" giving innovators guidance on how to protect intellectual property in specific countries such as China, Korea and Mexico. For questions regarding patent enforcement issues, applicants may call the U.S. Government hotline at 1-866-999-HALT (1-866-999-4158).

LICENSE FOR FOREIGN FILING UNDER**Title 35, United States Code, Section 184****Title 37, Code of Federal Regulations, 5.11 & 5.15****GRANTED**

The applicant has been granted a license under 35 U.S.C. 184, if the phrase "IF REQUIRED, FOREIGN FILING LICENSE GRANTED" followed by a date appears on this form. Such licenses are issued in all applications where

the conditions for issuance of a license have been met, regardless of whether or not a license may be required as set forth in 37 CFR 5.15. The scope and limitations of this license are set forth in 37 CFR 5.15(a) unless an earlier license has been issued under 37 CFR 5.15(b). The license is subject to revocation upon written notification. The date indicated is the effective date of the license, unless an earlier license of similar scope has been granted under 37 CFR 5.13 or 5.14.

This license is to be retained by the licensee and may be used at any time on or after the effective date thereof unless it is revoked. This license is automatically transferred to any related applications(s) filed under 37 CFR 1.53(d). This license is not retroactive.

The grant of a license does not in any way lessen the responsibility of a licensee for the security of the subject matter as imposed by any Government contract or the provisions of existing laws relating to espionage and the national security or the export of technical data. Licensees should apprise themselves of current regulations especially with respect to certain countries, of other agencies, particularly the Office of Defense Trade Controls, Department of State (with respect to Arms, Munitions and Implements of War (22 CFR 121-128)); the Bureau of Industry and Security, Department of Commerce (15 CFR parts 730-774); the Office of Foreign Assets Control, Department of Treasury (31 CFR Parts 500+) and the Department of Energy.

NOT GRANTED

No license under 35 U.S.C. 184 has been granted at this time, if the phrase "IF REQUIRED, FOREIGN FILING LICENSE GRANTED" DOES NOT appear on this form. Applicant may still petition for a license under 37 CFR 5.12, if a license is desired before the expiration of 6 months from the filing date of the application. If 6 months has lapsed from the filing date of this application and the licensee has not received any indication of a secrecy order under 35 U.S.C. 181, the licensee may foreign file the application pursuant to 37 CFR 5.15(b).

PATENT APPLICATION FEE DETERMINATION RECORD

Substitute for Form PTO-875

Application or Docket Number
13/103,310

APPLICATION AS FILED - PART I

(Column 1) (Column 2)

FOR	NUMBER FILED	NUMBER EXTRA
BASIC FEE (37 CFR 1.16(a), (b), or (c))	N/A	N/A
SEARCH FEE (37 CFR 1.16(k), (l), or (m))	N/A	N/A
EXAMINATION FEE (37 CFR 1.16(o), (p), or (q))	N/A	N/A
TOTAL CLAIMS (37 CFR 1.16(j))	20	minus 20 = *
INDEPENDENT CLAIMS (37 CFR 1.16(h))	2	minus 3 = *
APPLICATION SIZE FEE (37 CFR 1.16(s))	If the specification and drawings exceed 100 sheets of paper, the application size fee due is \$270 (\$135 for small entity) for each additional 50 sheets or fraction thereof. See 35 U.S.C. 41(a)(1)(G) and 37 CFR 1.16(s).	
MULTIPLE DEPENDENT CLAIM PRESENT (37 CFR 1.16(j))		

* If the difference in column 1 is less than zero, enter "0" in column 2.

SMALL ENTITY

RATE(\$)	FEE(\$)
N/A	
N/A	
N/A	
TOTAL	

OR OTHER THAN SMALL ENTITY

RATE(\$)	FEE(\$)
N/A	330
N/A	540
N/A	220
x 52 =	0.00
x 220 =	0.00
	0.00
	0.00
TOTAL	1090

APPLICATION AS AMENDED - PART II

(Column 1) (Column 2) (Column 3)

AMENDMENT A		CLAIMS REMAINING AFTER AMENDMENT		HIGHEST NUMBER PREVIOUSLY PAID FOR	PRESENT EXTRA
	Total (37 CFR 1.16(i))	*	Minus	**	=
Independent (37 CFR 1.16(h))	*	Minus	***	=	
Application Size Fee (37 CFR 1.16(s))					
FIRST PRESENTATION OF MULTIPLE DEPENDENT CLAIM (37 CFR 1.16(j))					

SMALL ENTITY

RATE(\$)	ADDITIONAL FEE(\$)
x =	
x =	
TOTAL ADD'L FEE	

OR OTHER THAN SMALL ENTITY

RATE(\$)	ADDITIONAL FEE(\$)
x =	
x =	
TOTAL ADD'L FEE	

(Column 1) (Column 2) (Column 3)

AMENDMENT B		CLAIMS REMAINING AFTER AMENDMENT		HIGHEST NUMBER PREVIOUSLY PAID FOR	PRESENT EXTRA
	Total (37 CFR 1.16(i))	*	Minus	**	=
Independent (37 CFR 1.16(h))	*	Minus	***	=	
Application Size Fee (37 CFR 1.16(s))					
FIRST PRESENTATION OF MULTIPLE DEPENDENT CLAIM (37 CFR 1.16(j))					

SMALL ENTITY

RATE(\$)	ADDITIONAL FEE(\$)
x =	
x =	
TOTAL ADD'L FEE	

OR OTHER THAN SMALL ENTITY

RATE(\$)	ADDITIONAL FEE(\$)
x =	
x =	
TOTAL ADD'L FEE	

* If the entry in column 1 is less than the entry in column 2, write "0" in column 3.
 ** If the "Highest Number Previously Paid For" IN THIS SPACE is less than 20, enter "20".
 *** If the "Highest Number Previously Paid For" IN THIS SPACE is less than 3, enter "3".
 The "Highest Number Previously Paid For" (Total or Independent) is the highest found in the appropriate box in column 1.



UNITED STATES PATENT AND TRADEMARK OFFICE

UNITED STATES DEPARTMENT OF COMMERCE
United States Patent and Trademark Office
Address: COMMISSIONER FOR PATENTS
P.O. Box 1450
Alexandria, Virginia 22313-1450
www.uspto.gov

APPLICATION NUMBER	FILING OR 371(C) DATE	FIRST NAMED APPLICANT	ATTY. DOCKET NO./TITLE
13/103,310	05/09/2011	Albert L. Arendt	MPW 3M1B

CONFIRMATION NO. 9050

POA ACCEPTANCE LETTER

David S. D'Ascenzo
DASCENZO INTELLECTUAL PROPERTY LAW, P.C.
Suite 925
522 S.W. 5th Avenue
Portland, OR 97204



Date Mailed: 06/06/2011

NOTICE OF ACCEPTANCE OF POWER OF ATTORNEY

This is in response to the Power of Attorney filed 05/27/2011.

The Power of Attorney in this application is accepted. Correspondence in this application will be mailed to the above address as provided by 37 CFR 1.33.

/mbayou/

Office of Data Management, Application Assistance Unit (571) 272-4000, or (571) 272-4200, or 1-888-786-0101



UNITED STATES PATENT AND TRADEMARK OFFICE

UNITED STATES DEPARTMENT OF COMMERCE
United States Patent and Trademark Office
Address: COMMISSIONER FOR PATENTS
P.O. Box 1450
Alexandria, Virginia 22313-1450
www.uspto.gov

Table with 4 columns: APPLICATION NUMBER (13/103,310), FILING OR 371(C) DATE (05/09/2011), FIRST NAMED APPLICANT (Albert L. Arendt), ATTY. DOCKET NO./TITLE (MPW 3M1B)

CONFIRMATION NO. 9050

PUBLICATION NOTICE

David S. D'Ascenzo
DASCENZO INTELLECTUAL PROPERTY LAW, P.C.
Suite 925
522 S.W. 5th Avenue
Portland, OR 97204



Title: BLOW-MOLDED WHEELS HAVING UNDERCUT TREADS, METHODS FOR PRODUCING THE SAME, AND CHILDREN'S RIDE-ON VEHICLES INCLUDING THE SAME

Publication No. US-2011-0221260-A1

Publication Date: 09/15/2011

NOTICE OF PUBLICATION OF APPLICATION

The above-identified application will be electronically published as a patent application publication pursuant to 37 CFR 1.211, et seq. The patent application publication number and publication date are set forth above.

The publication may be accessed through the USPTO's publically available Searchable Databases via the Internet at www.uspto.gov. The direct link to access the publication is currently http://www.uspto.gov/patft/.

The publication process established by the Office does not provide for mailing a copy of the publication to applicant. A copy of the publication may be obtained from the Office upon payment of the appropriate fee set forth in 37 CFR 1.19(a)(1). Orders for copies of patent application publications are handled by the USPTO's Office of Public Records. The Office of Public Records can be reached by telephone at (703) 308-9726 or (800) 972-6382, by facsimile at (703) 305-8759, by mail addressed to the United States Patent and Trademark Office, Office of Public Records, Alexandria, VA 22313-1450 or via the Internet.

In addition, information on the status of the application, including the mailing date of Office actions and the dates of receipt of correspondence filed in the Office, may also be accessed via the Internet through the Patent Electronic Business Center at www.uspto.gov using the public side of the Patent Application Information and Retrieval (PAIR) system. The direct link to access this status information is currently http://pair.uspto.gov/. Prior to publication, such status information is confidential and may only be obtained by applicant using the private side of PAIR.

Further assistance in electronically accessing the publication, or about PAIR, is available by calling the Patent Electronic Business Center at 1-866-217-9197.

Office of Data Management, Application Assistance Unit (571) 272-4000, or (571) 272-4200, or 1-888-786-0101



UNITED STATES PATENT AND TRADEMARK OFFICE

UNITED STATES DEPARTMENT OF COMMERCE
United States Patent and Trademark Office
Address: COMMISSIONER FOR PATENTS
P.O. Box 1450
Alexandria, Virginia 22313-1450
www.uspto.gov

APPLICATION NO.	FILING DATE	FIRST NAMED INVENTOR	ATTORNEY DOCKET NO.	CONFIRMATION NO.
13/103,310	05/09/2011	Albert L. Arendt	MPW 3MIB	9050
	7590	11/10/2011	EXAMINER	
David S. D'Ascenzo DASCENZO INTELLECTUAL PROPERTY LAW, P.C. Suite 925 522 S.W. 5th Avenue Portland, OR 97204			STABLEY, MICHAEL R	
			ART UNIT	PAPER NUMBER
			3611	
			MAIL DATE	DELIVERY MODE
			11/10/2011	PAPER

Please find below and/or attached an Office communication concerning this application or proceeding.

The time period for reply, if any, is set in the attached communication.

Office Action Summary	Application No.	Applicant(s)	
	13/103,310	ARENDR ET AL.	
	Examiner	Art Unit	
	MICHAEL STABLEY	3611	

-- The MAILING DATE of this communication appears on the cover sheet with the correspondence address --

Period for Reply

A SHORTENED STATUTORY PERIOD FOR REPLY IS SET TO EXPIRE 3 MONTH(S) OR THIRTY (30) DAYS, WHICHEVER IS LONGER, FROM THE MAILING DATE OF THIS COMMUNICATION.

- Extensions of time may be available under the provisions of 37 CFR 1.136(a). In no event, however, may a reply be timely filed after SIX (6) MONTHS from the mailing date of this communication.
- If NO period for reply is specified above, the maximum statutory period will apply and will expire SIX (6) MONTHS from the mailing date of this communication.
- Failure to reply within the set or extended period for reply will, by statute, cause the application to become ABANDONED (35 U.S.C. § 133). Any reply received by the Office later than three months after the mailing date of this communication, even if timely filed, may reduce any earned patent term adjustment. See 37 CFR 1.704(b).

Status

- 1) Responsive to communication(s) filed on 09 May 2011.
- 2a) This action is **FINAL**.
- 2b) This action is non-final.
- 3) An election was made by the applicant in response to a restriction requirement set forth during the interview on _____; the restriction requirement and election have been incorporated into this action.
- 4) Since this application is in condition for allowance except for formal matters, prosecution as to the merits is closed in accordance with the practice under *Ex parte Quayle*, 1935 C.D. 11, 453 O.G. 213.

Disposition of Claims

- 5) Claim(s) 1-20 is/are pending in the application.
 - 5a) Of the above claim(s) _____ is/are withdrawn from consideration.
- 6) Claim(s) 20 is/are allowed.
- 7) Claim(s) 1-8, 18 and 19 is/are rejected.
- 8) Claim(s) 9-17 is/are objected to.
- 9) Claim(s) _____ are subject to restriction and/or election requirement.

Application Papers

- 10) The specification is objected to by the Examiner.
- 11) The drawing(s) filed on 09 May 2011 is/are: a) accepted or b) objected to by the Examiner.
 - Applicant may not request that any objection to the drawing(s) be held in abeyance. See 37 CFR 1.85(a).
 - Replacement drawing sheet(s) including the correction is required if the drawing(s) is objected to. See 37 CFR 1.121(d).
- 12) The oath or declaration is objected to by the Examiner. Note the attached Office Action or form PTO-152.

Priority under 35 U.S.C. § 119

- 13) Acknowledgment is made of a claim for foreign priority under 35 U.S.C. § 119(a)-(d) or (f).
 - a) All b) Some * c) None of:
 - 1. Certified copies of the priority documents have been received.
 - 2. Certified copies of the priority documents have been received in Application No. _____.
 - 3. Copies of the certified copies of the priority documents have been received in this National Stage application from the International Bureau (PCT Rule 17.2(a)).

* See the attached detailed Office action for a list of the certified copies not received.

Attachment(s)

- 1) Notice of References Cited (PTO-892)
- 2) Notice of Draftperson's Patent Drawing Review (PTO-948)
- 3) Information Disclosure Statement(s) (PTO/SB/08)
 - Paper No(s)/Mail Date 5/9/11.
- 4) Interview Summary (PTO-413)
 - Paper No(s)/Mail Date. _____.
- 5) Notice of Informal Patent Application
- 6) Other: _____.

DETAILED ACTION

Drawings

1. The drawings are objected to under 37 CFR 1.83(a). The drawings must show every feature of the invention specified in the claims. Therefore, the recessed region being between the first and second regions must be shown or the feature(s) canceled from the claim(s). The drawings all appear to have a raised central region as opposed to a recessed one. No new matter should be entered.

Corrected drawing sheets in compliance with 37 CFR 1.121(d) are required in reply to the Office action to avoid abandonment of the application. Any amended replacement drawing sheet should include all of the figures appearing on the immediate prior version of the sheet, even if only one figure is being amended. The figure or figure number of an amended drawing should not be labeled as "amended." If a drawing figure is to be canceled, the appropriate figure must be removed from the replacement sheet, and where necessary, the remaining figures must be renumbered and appropriate changes made to the brief description of the several views of the drawings for consistency. Additional replacement sheets may be necessary to show the renumbering of the remaining figures. Each drawing sheet submitted after the filing date of an application must be labeled in the top margin as either "Replacement Sheet" or "New Sheet" pursuant to 37 CFR 1.121(d). If the changes are not accepted by the examiner, the applicant will be notified and informed of any required corrective action in the next Office action. The objection to the drawings will not be held in abeyance.

Claim Rejections - 35 USC § 103

2. The following is a quotation of 35 U.S.C. 103(a) which forms the basis for all obviousness rejections set forth in this Office action:

(a) A patent may not be obtained though the invention is not identically disclosed or described as set forth in section 102 of this title, if the differences between the subject matter sought to be patented and the prior art are such that the subject matter as a whole would have been obvious at the time the invention was made to a person having ordinary skill in the art to which said subject matter pertains. Patentability shall not be negated by the manner in which the invention was made.

3. Claims 1-8, 18, and 19 rejected under 35 U.S.C. 103(a) as being unpatentable over Damon (US 2005/0056474) in view of Markling (U.S. 5,518,682).

In re claim 1, Damon discloses a children's ride-on vehicle (10), comprising: a vehicle body (12) having at least one seat sized for a child; a plurality of wheels rotatably coupled to the vehicle body, wherein the plurality of wheels includes at least one driven wheel (36, 38) and at least one steerable wheel (32, 34), wherein at least one of the plurality of wheels is a blow-molded wheel that comprises a blow-molded wheel body having a diameter, an outer surface, first and second sidewalls, a central circumference, and an axis, wherein the blow-molded wheel body is configured to rotate about the axis, wherein the outer surface and the central circumference extend circumferentially around the blow-molded wheel body and between the first and second sidewalls, and wherein the central circumference is equidistant from the first and second sidewalls; a first region of the outer surface, wherein the first region is disposed between the first sidewall and the central circumference of the blow-molded wheel body; a second region of the outer surface, wherein the second region is disposed between the second sidewall and the central circumference of the blow-molded wheel body; but does not disclose a recessed region between the first region and the second region,

Art Unit: 3611

wherein the first region and the second region are directly adjacent to the recessed region, and wherein a first radial distance from the axis to the first region and a second radial distance from the axis to the second region both exceed a third radial distance from the axis to the recessed region by at least the larger of 1/8 inch and 0.1% of the diameter. Markling, however, does disclose a first region (right 22) of the outer surface, wherein the first region is disposed between the first sidewall and the central circumference of the blow-molded wheel body; a second region (left 22) of the outer surface, wherein the second region is disposed between the second sidewall and the central circumference of the blow-molded wheel body; and a recessed region (25) between the first region and the second region, wherein the first region and the second region are directly adjacent to the recessed region, and wherein a first radial distance (to the outermost portion of right 22) from the axis to the first region and a second radial distance (to the outermost portion of left 22) from the axis to the second region both exceed a third radial distance from the axis to the recessed region by at least the larger of 1/8 inch and 0.1% of the diameter as shown in Figures 2 and 3. It would have been obvious to one having ordinary skill in the art at the time the invention was made to modify the wheel of Damon such that it comprised the tread pattern of Markling to support the vehicle.

In re claim 2, Markling further discloses wherein the recessed region coincides with the central circumference as shown in Figure 3.

In re claim 3, Markling further discloses wherein the recessed region overlaps the central circumference as shown in Figure 3.

Art Unit: 3611

In re claim 4, Markling further discloses wherein the blow-molded wheel body has a part line, and wherein the recessed region coincides with the part line as shown in Figure 3.

In re claim 5, Markling further discloses wherein the blow-molded wheel body has a part line, wherein the central circumference coincides with the part line, and wherein the recessed region overlaps the central circumference as shown in Figure 3.

In re claim 6, Markling further discloses wherein the first region and the second region of the outer surface are smooth around an entire circumference of the blow-molded wheel body as shown in Figure 1.

In re claim 7, Markling further discloses wherein the first radial distance and the second radial distance are generally constant around an entire circumference of the blow-molded wheel body as shown in Figure 1.

In re claim 8, Markling further discloses wherein the first region and the second region of the outer surface are substantially smooth around an entire circumference of the blow-molded wheel body as shown in Figure 1.

In re claim 18, Markling further discloses wherein the recessed region defines a channel having a generally rectangular cross-section and extending around an entire circumference of the blow-molded wheel body as shown in Figures 1 and 3.

In re claim 19, Markling further discloses wherein the channel extends around the central circumference of the blow-molded wheel body as shown in Figure 1.

Art Unit: 3611

Allowable Subject Matter

4. Claims 9-17 objected to as being dependent upon a rejected base claim, but would be allowable if rewritten in independent form including all of the limitations of the base claim and any intervening claims.

The following is a statement of reasons for the indication of allowable subject matter: The specific limitations of “further comprises a third region of the outer surface, wherein the third region is disposed between the first sidewall and the first region; and a fourth region of the outer surface, wherein the fourth region is disposed between the second sidewall and the second region; wherein the third region and the fourth region include a plurality of tread blocks on the outer surface, wherein the plurality of tread blocks are separated and spaced apart from each other on the outer surface” is not anticipated or made obvious by the prior art of record in the examiner’s opinion.

5. Claim 20 allowed.

The following is a statement of reasons for the indication of allowable subject matter: The specific limitations of “a third region of the outer surface, wherein the third region is disposed between the first sidewall and the first region, and wherein the third region includes a plurality of spaced-apart tread blocks on the outer surface; and a fourth region of the outer surface, wherein the fourth region is disposed between the second sidewall and the second region, and wherein fourth region includes a plurality of spaced-apart tread blocks on the outer surface” is not anticipated or made obvious by the prior art of record in the examiner’s opinion.

Conclusion

Any inquiry concerning this communication or earlier communications from the examiner should be directed to MICHAEL STABLEY whose telephone number is (571)270-3249. The examiner can normally be reached on M-F 9-5:30.

If attempts to reach the examiner by telephone are unsuccessful, the examiner's supervisor, Lesley D. Morris can be reached on 571-272-6651. The fax phone number for the organization where this application or proceeding is assigned is 571-273-8300.

Information regarding the status of an application may be obtained from the Patent Application Information Retrieval (PAIR) system. Status information for published applications may be obtained from either Private PAIR or Public PAIR. Status information for unpublished applications is available through Private PAIR only. For more information about the PAIR system, see <http://pair-direct.uspto.gov>. Should you have questions on access to the Private PAIR system, contact the Electronic Business Center (EBC) at 866-217-9197 (toll-free). If you would like assistance from a USPTO Customer Service Representative or access to the automated information system, call 800-786-9199 (IN USA OR CANADA) or 571-272-1000.

/Michael R Stabley/
Examiner, Art Unit 3611

/Joanne Silbermann/
Primary Examiner, Art Unit 3611

Notice of References Cited	Application/Control No. 13/103,310	Applicant(s)/Patent Under Reexamination ARENDE ET AL.	
	Examiner MICHAEL STABLEY	Art Unit 3611	Page 1 of 1

U.S. PATENT DOCUMENTS

*	Document Number Country Code-Number-Kind Code	Date MM-YYYY	Name	Classification
*	A US-4,088,523 A	05-1978	Gallizia et al.	156/125
	B US-			
	C US-			
	D US-			
	E US-			
	F US-			
	G US-			
	H US-			
	I US-			
	J US-			
	K US-			
	L US-			
	M US-			

FOREIGN PATENT DOCUMENTS

*	Document Number Country Code-Number-Kind Code	Date MM-YYYY	Country	Name	Classification
	N				
	O				
	P				
	Q				
	R				
	S				
	T				

NON-PATENT DOCUMENTS

*	Document Number Country Code-Number-Kind Code	Date MM-YYYY	Country	Name	Classification
	Include as applicable: Author, Title Date, Publisher, Edition or Volume, Pertinent Pages)				
	U				
	V				
	W				
	X				

*A copy of this reference is not being furnished with this Office action. (See MPEP § 707.05(a).)
Dates in MM-YYYY format are publication dates. Classifications may be US or foreign.

FORM PTO-1449		DOCKET NUMBER		APPLICATION NUMBER			
INFORMATION DISCLOSURE CITATION IN AN APPLICATION		MPW 3M1B					
		APPLICANTS ALBERT L. ARENDT, JAMES R. CARDUCCI and CHRISTOPHER F. LUCAS					
		FILING DATE May 9, 2011		GROUP ART UNIT			
U.S. PATENT DOCUMENTS							
EXAMINER INITIAL	DOCUMENT NUMBER	DATE	NAME	CLASS	SUB CLASS	FIL. DATE IF APPROP.	
	2008/0006456	1/10/2008	Lucas et al.				
	2005/0056474	3/17/2005	Damon				
	2004/0070262	4/15/2004	Markling				
	2003/0085611	5/8/2003	Markling				
	6,953,333	10/11/2005	Feuerherm et al.				
	6,913,324	7/5/2005	Markling				
	6,896,335	5/24/2005	Markling				
	6,872,354	3/29/2005	Mol et al.				
	6,591,986	7/15/2003	Soehlen et al.				
	6,520,597	2/18/2003	Markling				
FOREIGN PATENT DOCUMENTS							
	DOCUMENT NUMBER	DATE	COUNTRY	CLASS	SUB CLASS	TRANSLATION YES NO	
	WO 2008/008173 A2	01/17/2008	WIPO			X	
	WO 2008/008173 A3	01/17/2008	WIPO			X	
	DE 10125824A1	12/5/2002	Germany				X
	JP 2002-192607	7/10/2002	Japan				X
OTHER DOCUMENTS							
		English-language abstract of German Patent No. DE 10125824A1, 2002.					
		English-language abstract of Japanese Patent Publication No. JP 2002-192607, 2002.					
EXAMINER			DATE CONSIDERED				
/Michael Stabley/			10/23/2011				

FORM PTO-1449		DOCKET NUMBER		APPLICATION NUMBER			
INFORMATION DISCLOSURE CITATION IN AN APPLICATION		MPW 3M1B					
		APPLICANTS ALBERT L. ARENDT, JAMES R. CARDUCCI and CHRISTOPHER F. LUCAS					
		FILING DATE May 9, 2011		GROUP ART UNIT			
U.S. PATENT DOCUMENTS							
EXAMINER INITIAL	DOCUMENT NUMBER	DATE	NAME	CLASS	SUB CLASS	FIL. DATE IF APPROP.	
	6,470,982	10/29/2002	Sitarski et al.				
	6,464,305	10/15/2002	Markling				
	6,446,981	9/10/2002	Wise et al.				
	7,621,543	11/24/2009	Arendt et al.				
	6,431,406	8/13/2002	Pruett				
	6,318,983	11/20/2001	Lopez et al.				
	6,170,920	1/9/2001	Markling				
	6,095,543	8/1/2000	McMahon et al.				
	6,068,161	5/30/2000	Soehnlén et al.				
	5,924,506	7/20/1999	Perego				
	5,908,124	6/1/1999	Klauke et al.				
	5,879,484	3/9/1999	Spragg et al.				
FOREIGN PATENT DOCUMENTS							
	DOCUMENT NUMBER	DATE	COUNTRY	CLASS	SUB CLASS	TRANSLATION YES NO	
	JP 5-124095	5/21/1993	Japan				X
	JP 4-65219	3/2/1992	Japan				X
OTHER DOCUMENTS							
		English-language abstract of Japanese Patent No. JP 5-124095, 1993.					
		English-language abstract of Japanese Patent No. JP 4-65219, 1992.					
EXAMINER			DATE CONSIDERED				
/Michael Stabley/			10/23/2011				

FORM PTO-1449		DOCKET NUMBER		APPLICATION NUMBER		
INFORMATION DISCLOSURE CITATION IN AN APPLICATION		MPW 3M1B				
		APPLICANTS ALBERT L. ARENDT, JAMES R. CARDUCCI and CHRISTOPHER F. LUCAS				
		FILING DATE May 9, 2011		GROUP ART UNIT		
U.S. PATENT DOCUMENTS						
EXAMINER INITIAL	DOCUMENT NUMBER	DATE	NAME	CLASS	SUB CLASS	FIL. DATE IF APPROP.
	5,810,452	9/22/1998	Hawthorne et al.			
	5,799,809	9/1/1998	Sako et al.			
	5,750,067	5/12/1998	Hellbrugge			
	5,736,168	4/7/1998	Goyal et al.			
	5,573,129	11/12/1996	Nagata et al.			
	5,556,601	9/17/1996	Huvey et al.			
	5,518,682	5/21/1996	Markling et al.			
	5,368,371	11/29/1994	Markling			
	5,316,377	5/31/1994	Markling et al.			
	5,316,135	5/31/1994	Kneer et al.			
	5,227,114	7/13/1993	Moore			
	5,219,594	6/15/1993	Meyer et al.			
FOREIGN PATENT DOCUMENTS						
	DOCUMENT NUMBER	DATE	COUNTRY	CLASS	SUB CLASS	TRANSLATION YES NO
	JP 1-034721	2/6/1989	Japan			X
OTHER DOCUMENTS						
	English-language abstract of Japanese Patent No. JP 1-034721, 1989.					
	International Search Report for International Application No. PCT/US07/17676.					
	Written Opinion of the International Searching Authority for International Application No. PCT/US07/17676.					
EXAMINER			DATE CONSIDERED			
/Michael Stabley/			10/23/2011			

FORM PTO-1449		DOCKET NUMBER		APPLICATION NUMBER		
INFORMATION DISCLOSURE CITATION IN AN APPLICATION		MPW 3M1B				
		APPLICANTS ALBERT L. ARENDT, JAMES R. CARDUCCI and CHRISTOPHER F. LUCAS				
		FILING DATE May 9, 2011		GROUP ART UNIT		
U.S. PATENT DOCUMENTS						
EXAMINER INITIAL	DOCUMENT NUMBER	DATE	NAME	CLASS	SUB CLASS	FIL. DATE IF APPROP.
	D327,048	6/16/1992	Markling et al.			
	5,104,198	4/14/1992	Prout et al.			
	4,889,480	12/26/1989	Nakamura et al.			
	4,884,961	12/5/1989	Iizuka et al.			
	4,854,849	8/8/1989	Sudo			
	4,832,307	5/23/1989	Watanabe et al.			
	4,717,113	1/5/1988	Martin			
	4,588,542	5/13/1986	Pierce			
	4,531,704	7/30/1985	Matthei			
	4,516,648	5/14/1985	Berger et al.			
	4,513,981	4/30/1985	DeGraaff et al.			
	4,323,411	4/6/1982	Uhlig			
FOREIGN PATENT DOCUMENTS						
	DOCUMENT NUMBER	DATE	COUNTRY	CLASS	SUB CLASS	TRANSLATION YES NO
OTHER DOCUMENTS						
EXAMINER			DATE CONSIDERED			
/Michael Stabley/			10/23/2011			

FORM PTO-1449		DOCKET NUMBER		APPLICATION NUMBER			
INFORMATION DISCLOSURE CITATION IN AN APPLICATION		MPW 3M1B					
		APPLICANTS ALBERT L. ARENDT, JAMES R. CARDUCCI and CHRISTOPHER F. LUCAS					
		FILING DATE May 9, 2011		GROUP ART UNIT			
U.S. PATENT DOCUMENTS							
EXAMINER INITIAL	DOCUMENT NUMBER	DATE	NAME	CLASS	SUB CLASS	FIL. DATE IF APPROP.	
	4,063,868	12/20/1977	Piotrowski				
	3,936,264	2/3/1976	Cornett III et al.				
	3,907,370	9/23/1975	Bard				
	3,888,545	6/10/1975	Braun				
	3,851,029	11/26/1974	Cornett III et al.				
	3,817,676	6/18/1974	Seefluth				
	3,779,688	12/18/1973	Jullien-Davin				
	3,730,658	5/1/1973	Marra				
	3,692,453	9/19/1972	Quigg				
	3,616,491	11/2/1971	Vollers				
	3,592,885	7/13/1971	Goins et al.				
	3,570,057	3/16/1971	Doyle				
FOREIGN PATENT DOCUMENTS							
	DOCUMENT NUMBER	DATE	COUNTRY	CLASS	SUB CLASS	TRANSLATION YES NO	
OTHER DOCUMENTS							
EXAMINER			DATE CONSIDERED				
/Michael Stabley/			10/23/2011				

FORM PTO-1449		DOCKET NUMBER		APPLICATION NUMBER		
INFORMATION DISCLOSURE CITATION IN AN APPLICATION		MPW 3M1B				
		APPLICANTS ALBERT L. ARENDT, JAMES R. CARDUCCI and CHRISTOPHER F. LUCAS				
		FILING DATE May 9, 2011		GROUP ART UNIT		
U.S. PATENT DOCUMENTS						
EXAMINER INITIAL	DOCUMENT NUMBER	DATE	NAME	CLASS	SUB CLASS	FIL. DATE IF APPROP.
	3,373,460	3/19/1968	Ladney, Jr.			
	3,264,780	8/9/1966	Doe			
	3,135,997	6/9/1964	Smyser			
	3,264,780	8/9/1966	Doe			
	3,029,468	4/17/1972	Valyi			
	2,601,700	7/1/1952	Pinsky et al.			
FOREIGN PATENT DOCUMENTS						
	DOCUMENT NUMBER	DATE	COUNTRY	CLASS	SUB CLASS	TRANSLATION YES NO
OTHER DOCUMENTS						
EXAMINER			DATE CONSIDERED			
/Michael Stabley/			10/23/2011			



UNITED STATES PATENT AND TRADEMARK OFFICE

UNITED STATES DEPARTMENT OF COMMERCE
 United States Patent and Trademark Office
 Address: COMMISSIONER FOR PATENTS
 P.O. Box 1450
 Alexandria, Virginia 22313-1450
 www.uspto.gov

BIB DATA SHEET

CONFIRMATION NO. 9050

SERIAL NUMBER 13/103,310	FILING or 371(c) DATE 05/09/2011	CLASS 280	GROUP ART UNIT 3611	ATTORNEY DOCKET NO. MPW 3M1B	
APPLICANTS Albert L. Arendt, West Seneca, NY; James R. Carducci, East Aurora, NY; Christopher F. Lucas, Cheektowaga, NY; ** CONTINUING DATA ***** This application is a CON of 12/577,565 10/12/2009 PAT 7,939,008 which is a DIV of 11/509,421 08/23/2006 PAT 7,621,543 ** FOREIGN APPLICATIONS ***** ** IF REQUIRED, FOREIGN FILING LICENSE GRANTED ** 05/19/2011					
Foreign Priority claimed <input type="checkbox"/> Yes <input checked="" type="checkbox"/> No 35 USC 119(a-d) conditions met <input type="checkbox"/> Yes <input checked="" type="checkbox"/> No Verified and /MICHAEL R STABLEY/ Acknowledged Examiner's Signature	<input type="checkbox"/> Met after Allowance Initials	STATE OR COUNTRY NY	SHEETS DRAWINGS 6	TOTAL CLAIMS 20	INDEPENDENT CLAIMS 2
ADDRESS David S. D'Ascenzo DASCENZO INTELLECTUAL PROPERTY LAW, P.C. Suite 925 522 S.W. 5th Avenue Portland, OR 97204 UNITED STATES					
TITLE BLOW-MOLDED WHEELS HAVING UNDERCUT TREADS, METHODS FOR PRODUCING THE SAME, AND CHILDREN'S RIDE-ON VEHICLES INCLUDING THE SAME					
FILING FEE RECEIVED 1220	FEES: Authority has been given in Paper No. _____ to charge/credit DEPOSIT ACCOUNT No. _____ for following:		<input type="checkbox"/> All Fees <input type="checkbox"/> 1.16 Fees (Filing) <input type="checkbox"/> 1.17 Fees (Processing Ext. of time) <input type="checkbox"/> 1.18 Fees (Issue) <input type="checkbox"/> Other _____ <input type="checkbox"/> Credit		

Search Notes 	Application/Control No. 13103310	Applicant(s)/Patent Under Reexamination ARENDR ET AL.
	Examiner MICHAEL STABLEY	Art Unit 3611

SEARCHED			
Class	Subclass	Date	Examiner
280	29	10/24/2011	MS
264	454, 501, 512, 523, 524	10/24/2011	MS
152	209.1	10/24/2011	MS

SEARCH NOTES		
Search Notes	Date	Examiner
EAST Search Results - See Attached	10/24/2011	MS

INTERFERENCE SEARCH			
Class	Subclass	Date	Examiner

/MICHAEL STABLEY/ Examiner.Art Unit 3611	
---	--

EAST Search History

EAST Search History (Prior Art)

Ref #	Hits	Search Query	DBs	Default Operator	Plurals	Time Stamp
S1	67	("2601700" "20030085611" "20040070262" "20050056474" "3029468" "3264780" "3373460" "3592885" "3616491" "3692453" "3730658" "3779688" "3817676" "3851029" "3888545" "3907370" "3936264" "3135997" "3570057" "4063868" "4323411" "4513981" "4531704" "4588842" "4717113" "4832307" "4854849" "4884961" "4889480" "4516648" "5104198" "5219594" "5227114" "5316135" "5316377" "5368371" "5518682" "5556601" "5573129" "5736168" "5750067" "5799809" "5810452"	US-PGPUB; USPAT; USOCR	OR	ON	2009/01/28 11:16

		"5908124" "5924506" "6068161" "6095543" "6170920" "6318983" "6431406" "6464305" "6520597" "6591986" "6872354" "6896335" "6913324" "6953333" "6470982").PN.				
S3	14	("3730594" "3894776" "4358162" "5104198" "5368371").PN. OR ("6170920").URPN.	US-PGPUB; USPAT; USOCR	OR	ON	2009/01/28 15:14
S4	325	(tire or wheel) near5 (blow adj mold\$3)	US-PGPUB; USPAT; USOCR	OR	ON	2009/01/28 15:23
S5	14	("3870372" "3960474" "4040670" "4088523" "4301850" "4722131" "5104198" "5114522" "5133591").PN. OR ("5518682").URPN.	US-PGPUB; USPAT; USOCR	OR	ON	2009/01/28 16:19
S6	18	("1560551" "1687113" "2969254" "3387894" "3870372" "4592595" "5104198" "5129709").PN. OR ("5316377").URPN.	US-PGPUB; USPAT; USOCR	OR	ON	2009/01/28 16:27

S7	14	("3870372" "3960474" "4040670" "4088523" "4301850" "4722131" "5104198" "5114522" "5133591").PN. OR ("5518682").URPN.	US-PGPUB; USPAT; USOCR	OR	ON	2009/03/20 14:14
S8	18	("1560551" "1687113" "2969254" "3387894" "3870372" "4592595" "5104198" "5129709").PN. OR ("5316377").URPN.	US-PGPUB; USPAT; USOCR	OR	ON	2009/03/20 14:15
S9	1277	280/29.ccls. or 264/454.ccls. or 152/209.1.ccls.	US-PGPUB; USPAT; USOCR	OR	ON	2009/08/03 15:49
S10	674	152/209.1.ccls.	US-PGPUB; USPAT; USOCR	OR	ON	2009/08/03 15:50
S12	72	("2601700" "20030085611" "20040070262" "20050056474" "20080006456" "3029468" "3135997" "3264780" "3373460" "3570057" "3592885" "3616491" "3692453" "3730658" "3779688" "3817676" "3851029" "3888545" "3907370" "3936264" "4063868" "4323411" "4513981" "4516648" "4531704"	US-PGPUB; USPAT; USOCR	OR	ON	2011/10/23 12:17

		"4588542" "4717113" "4832307" "4854849" "4884961" "4889480" "5104198" "5219594" "5227114" "5316135" "5316377" "5368371" "5518682" "5556601" "5573129" "5736168" "5750067" "5799809" "5810452" "5879484" "5908124" "5924506" "6068161" "6095543" "6170920" "6318983" "6431406" "6446981" "6464305" "6470982" "6520597" "6591986" "6872354" "6896335" "6913324" "6953333" "7621543" "D327048").PN.				
S13	1411	280/29.ccls. or 264/454.ccls. or 152/209.1.ccls.	US-PGPUB; USPAT; USOCR	OR	ON	2011/10/23 12:17
S14	1650	264/501.ccls. or 264/512.ccls. or 264/523.ccls. or 264/524.ccls.	US-PGPUB; USPAT; USOCR	OR	ON	2011/10/23 12:19
S15	1650	264/501.ccls. or 264/512.ccls. or 264/523.ccls. or 264/524.ccls.	US-PGPUB; USPAT; USOCR	OR	ON	2011/10/24 10:00

S16	680	S15 and (blow adj mold\$3)	US-PGPUB; USPAT; USOCR	OR	ON	2011/10/24 10:00
S17	39	S15 and ((blow adj mold\$3) same (tire or wheel))	US-PGPUB; USPAT; USOCR	OR	ON	2011/10/24 10:01

EAST Search History (Interference)

Ref #	Hits	Search Query	DBs	Default Operator	Plurals	Time Stamp
S11	0	(vehicle and body and wheels and molded and tread and surface and region and radial and distance and steering and assembly and drive).clm.	USPAT; UPAD	OR	ON	2009/08/03 16:05

10/24/2011 4:44:59 PM
H:\Workspaces\13103310.wsp

IN THE UNITED STATES PATENT AND TRADEMARK OFFICE

January 30, 2012

In re Application of:

ALBERT L. ARENDT, JAMES R. CARDUCCI, and CHRISTOPHER F. LUCAS

Serial No. : 13/103,310 Group Art Unit: 3611
Filed : May 9, 2011 Examiner: Michael R. Stabley
For : BLOW-MOLDED WHEELS HAVING UNDERCUT TREADS,
METHODS FOR PRODUCING THE SAME, AND CHILDREN'S
RIDE-ON VEHICLES INCLUDING THE SAME

Mail Stop AMENDMENT

Commissioner for Patents
PO Box 1450
Alexandria, Virginia 22313-1450

AMENDMENT AND RESPONSE TO OFFICE ACTION

In response to the Office action dated November 10, 2011, please consider the following amendments and remarks.

Amendments to the Specification	Begin on page 2.
Listing of Claims	Begins on page 4.
Amendments to the Drawings	Begin on page 10. (1 replacement drawing sheet attached.)
Remarks	Begin on page 11.

Amendments to the Specification

Please make the following amendments to the specification. Material to be inserted in replacement paragraphs or sections is in **bold and underline**, and material to be deleted is in strikeout or (if the deletion is of five or fewer consecutive characters or would be difficult to see) in bold double brackets [[]].

Please replace the paragraph beginning at page 19, line 21, with the following rewritten paragraph:

In some embodiments, tread surface 100 may, but is not required to, include a third region 116, as shown in Figs. 5 and 6. The third region 116 of tread surface 100 may include the portion, or portions, of the tread surface 100 that is, or are, located a third radial distance 118 from the axis 94 and is, or are, disposed between the second region 108 of tread surface 100 and the second sidewall 98 of the blow-molded body 92. As shown in the illustrative, non-exclusive example presented in Fig. 6, the third radial distance 118 from the axis 94 to the third region 116 exceeds the second radial distance 112 from the axis 94 to the second region 108 by at least a second predetermined threshold 120. Further, as shown in the illustrative, non-exclusive example presented in Fig. 6, the third radial distance 118 from the axis 94 to the third region 116 may exceed the first radial distance 110 from the axis 94 to the first region 106. However, it is within the scope of the present disclosure for one or more of the first radial distance 110 from the axis 94 to the first region 106 and the second radial distance 112 from the axis to the second region 108 to exceed the third radial distance 118 from the axis 94 to the third region 116. **For example, in dashed lines in Fig. 6, first and second radial distances 110 and 112 are depicted as being greater than third radial distance 118.** Further, it is within the scope of the

present disclosure for the third radial distance 118 to be equal, or approximately equal to, the first radial distance 110.

Please replace the paragraph beginning at page 20, line 15, with the following rewritten paragraph:

In some embodiments, tread surface 100 may include a fourth region 122, as shown in Figs. 5 and 6. The fourth region 122 of tread surface 100 may include the portion, or portions, of the tread surface 100 that is, or are, located a fourth radial distance 124 from the axis 94 and is, or are, disposed between at least a first portion 126 of the third region 116 of tread surface 100 and the second sidewall 98 of the blow-molded body 92. As shown in the illustrative, non-exclusive example presented in Fig. 6, the third radial distance 118 from the axis 94 to the third region 116 may exceed the fourth radial distance 124 from the axis 94 to the fourth region 122 by at least a third predetermined threshold 128. The fourth region 122 of tread surface 100 may be disposed between the part line 102 and the second sidewall 98, as shown in the illustrative, non-exclusive example presented in Figs. 5 and 6. However, it is within the scope of the present disclosure for at least a portion of the fourth region 122 to be disposed between the part line 102 and the first sidewall 96. As shown **both in solid lines and dashed lines** in the illustrative, non-exclusive example presented in Fig. 6, the fourth radial distance 124 may be approximately equal to the second radial distance 112. However, it is within the scope of the present disclosure for the fourth radial distance 124 to be greater than or less than the second radial distance 112.

Claim Listing

1. (Original) A children's ride-on vehicle, comprising:

a vehicle body having at least one seat sized for a child;

a plurality of wheels rotatably coupled to the vehicle body, wherein the plurality of wheels includes at least one driven wheel and at least one steerable wheel, wherein at least one of the plurality of wheels is a blow-molded wheel that comprises:

a blow-molded wheel body having a diameter, an outer surface, first and second sidewalls, a central circumference, and an axis, wherein the blow-molded wheel body is configured to rotate about the axis, wherein the outer surface and the central circumference extend circumferentially around the blow-molded wheel body and between the first and second sidewalls, and wherein the central circumference is equidistant from the first and second sidewalls;

a first region of the outer surface, wherein the first region is disposed between the first sidewall and the central circumference of the blow-molded wheel body;

a second region of the outer surface, wherein the second region is disposed between the second sidewall and the central circumference of the blow-molded wheel body; and

a recessed region between the first region and the second region, wherein the first region and the second region are directly adjacent to the recessed region, and wherein a first radial distance from the axis to the first region and a second radial distance from the axis to the second region both exceed a third radial distance from the axis to the recessed region by at least the larger of 1/8 inch and 0.1% of the diameter.

2. (Original) The children's ride-on vehicle of claim 1, wherein the recessed region coincides with the central circumference.

3. (Original) The children's ride-on vehicle of claim 1, wherein the recessed region overlaps the central circumference.

4. (Original) The children's ride-on vehicle of claim 1, wherein the blow-molded wheel body has a part line, and wherein the recessed region coincides with the part line.

5. (Original) The children's ride-on vehicle of claim 1, wherein the blow-molded wheel body has a part line, wherein the central circumference coincides with the part line, and wherein the recessed region overlaps the central circumference.

6. (Original) The children's ride-on vehicle of claim 1, wherein the first region and the second region of the outer surface are smooth around an entire circumference of the blow-molded wheel body.

7. (Original) The children's ride-on vehicle of claim 1, wherein the first radial distance and the second radial distance are generally constant around an entire circumference of the blow-molded wheel body.

8. (Original) The children's ride-on vehicle of claim 1, wherein the first region and the second region of the outer surface are substantially smooth around an entire circumference of the blow-molded wheel body.

9. (Original) The children's ride-on vehicle of claim 8, wherein the blow-molded wheel further comprises:

a third region of the outer surface, wherein the third region is disposed between the first sidewall and the first region; and

a fourth region of the outer surface, wherein the fourth region is disposed between the second sidewall and the second region;

wherein the third region and the fourth region include a plurality of tread blocks on the outer surface, wherein the plurality of tread blocks are separated and spaced apart from each other on the outer surface.

10. (Original) The children's ride-on vehicle of claim 9, wherein at least a subset of the plurality of tread blocks have more than one radial distance from the axis to the respective tread block.

11. (Original) The children's ride-on vehicle of claim 9, wherein at least a portion of the outer surface between the plurality of tread blocks is generally V-shaped.

12. (Original) The children's ride-on vehicle of claim 9, wherein at least a subset of the plurality of tread blocks are generally V-shaped.

13. (Original) The children's ride-on vehicle of claim 9, wherein at least a subset of the plurality of tread blocks are generally U-shaped.

14. (Original) The children's ride-on vehicle of claim 9, wherein at least a subset of the plurality of tread blocks are partially coextensive with the first region and the second region.

15. (Original) The children's ride-on vehicle of claim 9, wherein at least a subset of the plurality of tread blocks extend from an adjacent portion of the outer surface by at least the larger of 1/8 inch and 0.1% of the diameter.

16. (Original) The children's ride-on vehicle of claim 9, wherein at least a subset of the plurality of tread blocks include walls extending from a base surface to define the respective tread blocks, wherein the walls extend at least partially transverse across the outer surface at angles relative to the central circumference.

17. (Original) The children's ride-on vehicle of claim 9, wherein at least a subset of the plurality of tread blocks partially extend onto at least one of the first sidewall and the second sidewall.

18. (Original) The children's ride-on vehicle of claim 1, wherein the recessed region defines a channel having a generally rectangular cross-section and extending around an entire circumference of the blow-molded wheel body.

19. (Original) The children's ride-on vehicle of claim 18, wherein the channel extends around the central circumference of the blow-molded wheel body.

20. (Original) A children's ride-on vehicle, comprising:

a vehicle body having at least one seat sized for a child;

a plurality of wheels rotatably coupled to the vehicle body, wherein the plurality of wheels includes at least one driven wheel and at least one steerable wheel, wherein at least one of the plurality of wheels is a blow-molded wheel that comprises:

a blow-molded wheel body having a diameter, an outer surface, first and second sidewalls, a central circumference, and an axis, wherein the blow-molded wheel body is configured to rotate about the axis, wherein the outer surface and the central circumference extend circumferentially around the blow-molded wheel body and between the first and second sidewalls, and wherein the central circumference is equidistant from the first and second sidewalls;

a first region of the outer surface, wherein the first region is disposed between the first sidewall and the central circumference of the blow-molded wheel body, and wherein the first region is smooth with a first radial distance from the axis to the first region that is generally constant around an entire circumference of the blow-molded wheel body;

a second region of the outer surface, wherein the second region is disposed between the second sidewall and the central circumference of the blow-molded wheel body, and wherein the second region is smooth with a second radial distance from the axis to the second region that is generally constant around an entire circumference of the blow-molded wheel body;

a recessed region between the first region and the second region, wherein the first region and the second region are directly adjacent to the recessed region, and wherein the first radial distance and the second radial distance both exceed a third radial distance from the axis to the recessed region by at least the larger of 1/8 inch and 0.1% of the diameter;

a third region of the outer surface, wherein the third region is disposed between the first sidewall and the first region, and wherein the third region includes a plurality of spaced-apart tread blocks on the outer surface; and

a fourth region of the outer surface, wherein the fourth region is disposed between the second sidewall and the second region, and wherein fourth region includes a plurality of spaced-apart tread blocks on the outer surface.

Amendments to the Drawings

Please replace sheet 3 of the drawings with the attached replacement sheet. The replacement sheet incorporates the desired changes and includes all of the Figures that appeared on the prior version of sheet 3.

Replacement sheet 3 includes revisions to Fig. 6, support for which is found in the specification, at least at page 20, lines 9–12 and page 21, lines 4–6.

Remarks

The above amendments and these remarks are responsive to the Office action mailed on November 10, 2011. In the Office action, the drawings were objected to for not showing every feature specified in the claims. Claims 1–8, 18, and 19 were rejected as being obvious over a proposed combination of U.S. Patent Application Publication No. 2005/0056474 to Damon (“Damon”) and U.S. Patent No. 5,518,682 to Markling (“Markling”). Claims 9–17 were indicated to include allowable subject matter, and claim 20 was allowed. Applicants presently amend the specification and the drawings as set forth above and in the attached replacement sheet, with no new matter being added. Applicants appreciate the indication of allowable subject matter and the allowance of claim 20. At this time, however, Applicants traverse the rejections and request reconsideration of the rejections and drawings objection for the reasons discussed below and in view of the presently submitted evidence. No amendments are presently made to the claims.

I. Objections to the Drawings.

As mentioned, the drawings were objected to for not showing every feature specified in the claims. Specifically, the Office action indicates that the “drawings all appear to have a raised central region as opposed to a recessed one.” [OA, p. 2.] Applicants do not disagree with this statement and presume that this objection relates to the corresponding subject matter of at least dependent claims 2–5 and 19. However, Fig. 6 presently is amended to illustrate an illustrative, non-exclusive example of a tread that includes a recessed central region. Support for this amendment is found at least at page 20, lines 9–12 (“However, it is within the scope of the present disclosure for one or more of the first radial distance 110 from the axis 94 to the first region 106 and the second radial distance 112 from the axis to the second region 108 to exceed

the third radial distance 118 from the axis 94 to the third region 116.”) and page 21, lines 4–6 (“As shown in the illustrative, non-exclusive example presented in Fig. 6, the fourth radial distance 124 may be approximately equal to the second radial distance 112.”) of the original specification. For consistency, these same passages are amended herein to reference the amendments to Fig. 6, despite the above-indicated portions of the specification already providing support for the amendments.

With entry of the present amendments to Fig. 6 and the specification, Applicants believe that the objection to the drawings is rendered moot. Accordingly, Applicants respectfully request withdrawal of the same.

II. Section 103 Rejections.

Independent claim 1 stands rejected as being obvious over a proposed combination of Damon and Markling; however, neither Damon nor Markling, nor any permissible combination thereof, discloses, teaches, or even suggests the following subject matter of independent claim 1 (with emphasis): “a blow-molded wheel body ... [with] *a recessed region* between the first region and the second region.”

In the Office action, Markling is cited for disclosing the above identified subject matter of independent claim 1. Specifically, the Office action cited to the structure indicated at 25 in Fig. 3 (reproduced below) as being the recited “recessed region” of a blow-molded wheel body. However, as plainly seen in Fig. 3 of Markling, the structure indicated at 25 is *not* a recessed region, and is instead a *raised* region with respect to the adjacent portions of the blow-molded portion of the illustrated wheel. In other words, Markling discloses the opposite of the subject matter of independent claim 1, and for at least this reason, the rejection of independent claim 1 should be withdrawn.

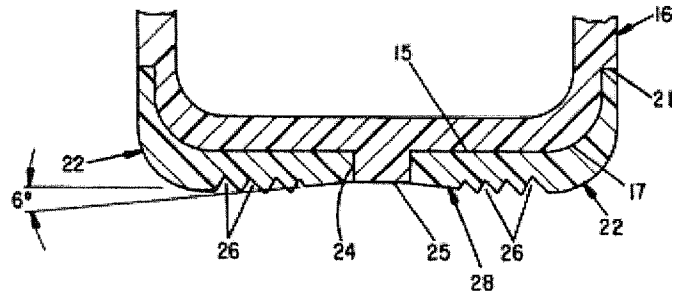

FIG. 3

Moreover, Applicants note that the Office action cites to the structure identified at 22 for disclosing the recited first and second regions of the blow-molded wheel body. However, the structure indicated at 22 is *not* part of the disclosed blow-molded wheel body of Markling. Rather, the “tread pieces 22 are constructed from a low density, relatively soft polyethylene material...” (Markling, column 5, lines 18–19), and are melt bonded to the surface of the blow-molded wheel body. *See* Markling column 5, lines 38–40. Accordingly, for at least this additional reason, the rejection of independent claim 1 should be withdrawn.

III. Evidence of Nonobviousness.

In addition to the Office action failing to establish a *prima facie* case of obviousness of independent claim 1 in view of Damon and Markling, Applicants presently and proactively submit, under 37 C.F.R. 1.132, a Declaration of Albert L. Arendt, with evidence establishing the nonobviousness of the subject matter of independent claim 1. The attached declaration was originally submitted in connection with co-owned U.S. Patent Application No. 11/509,421, now U.S. Patent No. 7,621,543, from which the present application claims priority. Specifically, in addition to the reasons expressed above, the subject matter of independent claim 1 is not obvious because one of ordinary skill in the art would not have been motivated to arrive at the following subject matter of independent claim 1 (with emphasis):

wherein a first radial distance from the axis to the first region and a second radial distance from the axis to the second region both exceed a third radial distance from the axis to the recessed region ***by at least the larger of 1/8 inch and 0.1% of the diameter.***

Mr. Arendt is one of the listed inventors of the present application and an engineer with 25 years of experience with molding components for children's products, including 10 years of experience with the design and molding, including blow-molding, of wheels for children's ride-on vehicles. [Arendt Decl. ¶ 3.] Briefly, and without reproducing the entirety of Mr. Arendt's declaration (which, as mentioned, was originally prepared for submission in the present application's parent), prior to Applicants' conception of the inventive subject matter of independent claim 1, only tread patterns having undercuts *less than 1/8 inch and/or less than 0.1% of the wheel's diameter* were possible for typical blow-molded wheel bodies of children's ride-on vehicles. [See specification, p. 3, lines 8–17 and Arendt Decl., ¶¶ 6–11.] Moreover, blow-molded wheel bodies having thresholds, or undercuts, greater than the larger of 1/8 inch and 0.1% of the wheel's diameter did not even exist prior to the inventive subject matter of the present application. [Arendt Decl., ¶ 10.] That is, even if one of ordinary skill in the art would have contemplated blow-molded wheel bodies having tread patterns with undercuts greater than the larger of 1/8 inch and 0.1% of the wheel's diameter, the technology simply did not exist to *enable* such wheel bodies. [See *id.* at ¶¶ 11–12.] Accordingly, it would not have been obvious to one of ordinary skill in the art of blow-molded wheel bodies of children's ride-on vehicles to provide, let alone attempt to produce, a blow-molded wheel body having a tread pattern with an undercut great than the larger of 1/8 inch and 0.1% of the wheel's diameter. [See *id.* at ¶ 12.]

For at least these additional reasons, independent claim 1 and the claims that depend therefrom are patentable over the prior art.

IV. Conclusion.

Applicants believe that this application is now in condition for allowance. Applicants therefore respectfully request that the Examiner issue a Notice of Allowance covering all of the pending claims. If the Examiner has any questions, or if a telephone interview would in any way advance prosecution, please contact the undersigned.

CERTIFICATE OF E-FILING

I hereby certify that this correspondence, the attached replacement drawing sheet and Declaration of Albert L. Arendt are being transmitted electronically via the United States Patent and Trademark Office's EFS-Web System on January 30, 2012.



David S. D'Ascenzo

Respectfully submitted,

DASCENZO INTELLECTUAL
PROPERTY LAW, P.C.



David S. D'Ascenzo
Registration No. 39,952
Customer No. 78569
DASCENZO INTELLECTUAL
PROPERTY LAW, P.C.
522 S.W. 5th Ave, Suite 925
Portland, Oregon 97204
Telephone: (503) 224-7529
Facsimile: (503) 224-7329

3/6

Fig. 5

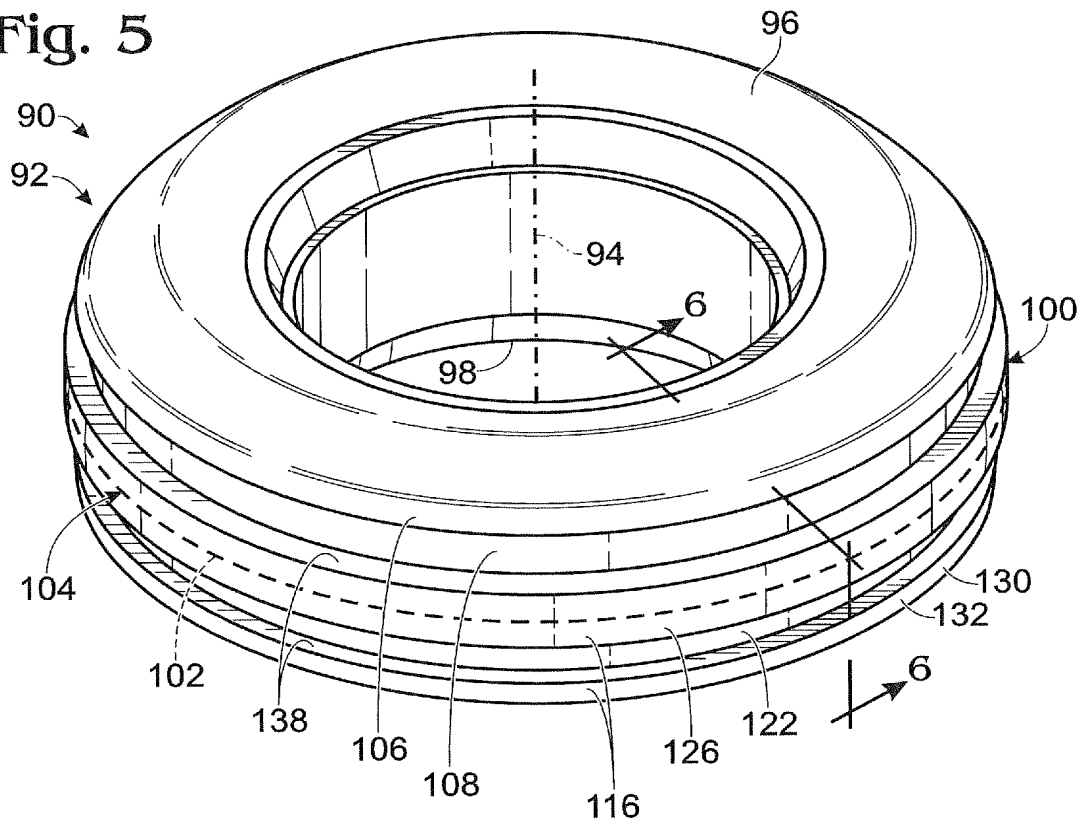
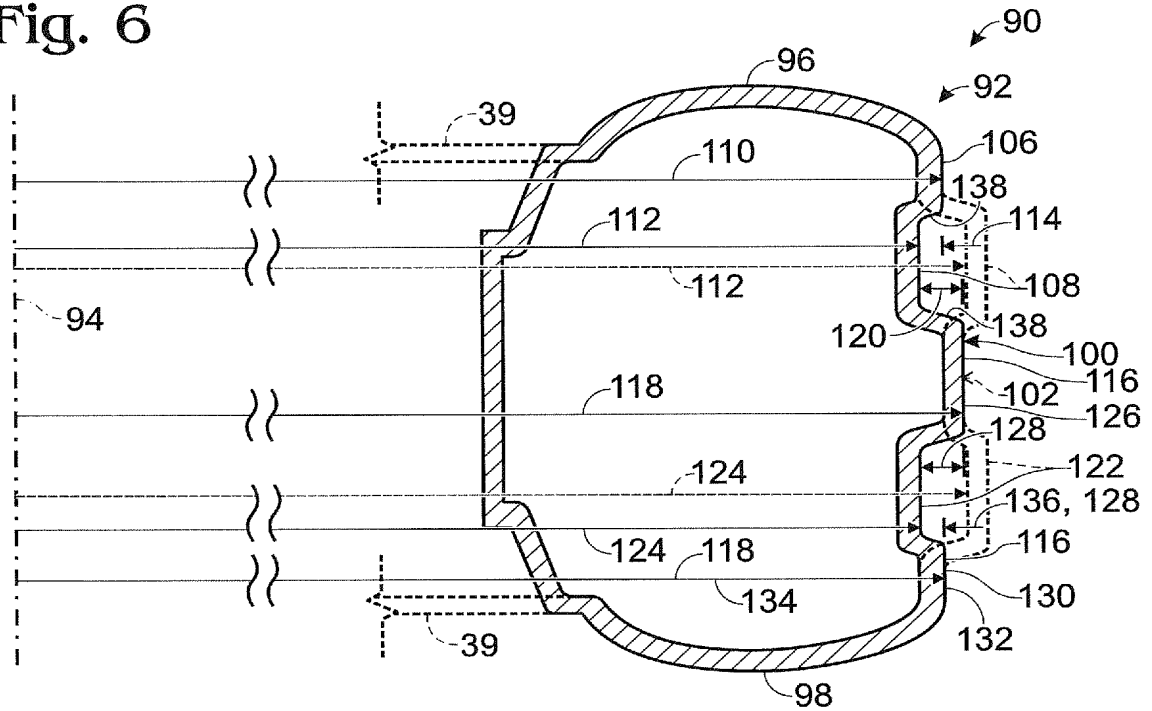

Fig. 6



IN THE UNITED STATES PATENT AND TRADEMARK OFFICE

In re Application of:

Albert L. Arendt et al.

Serial No. : 11/509,421

Filed : August 23, 2006

For : BLOW-MOLDED WHEELS HAVING UNDERCUT TREADS,
METHODS FOR PRODUCING THE SAME,
AND CHILDREN'S RIDE-ON VEHICLES INCLUDING THE SAME

DECLARATION OF ALBERT L. ARENDT UNDER 37 C.F.R. 1.132

I, ALBERT L. ARENDT, declare:

General Background

1. I have an associate's degree in Mechanical Technology.
2. I have been working for Fisher-Price, Inc., a division of Mattel, Inc., for approximately 32 years. Mattel, Inc. is the assignee of U.S. Patent Application Serial No. 11/509,421 (the "421 application").
3. I have been involved in the design and production of molded plastic components for children's products for approximately 25 years, including the design of at least 50 different blow-molded parts and the manufacturing thereof. During this time, I have developed substantial experience relating to the design, prototyping, debugging, and production of blow-molded parts, including design, debugging, and operation of the corresponding molds and molding processes. For approximately the last 10 years, I have focused primarily on the design and manufacturing of molded wheels and other parts for children's ride-on vehicles. This molding includes blow molding of such wheels and parts.

4. I currently hold the title of Staff Engineer - Plastics/Tooling.

The 11/509,421 Patent Application

5. I am one of the listed inventors of the '421 application.
6. The following is an excerpt from the Background of the Disclosure section of the '421 application, and which I restate herein:

The wheels used on children's ride-on vehicles are often blow-molded from a suitable material, such as a plastic. Blow-molded wheels are conventionally formed using a mold that has two portions, which typically separate in an axial direction. The portions of the mold collectively define a cavity that defines, or corresponds to, the shape of the blow-molded wheels, including the tread surface. The seam, or part line, between the axially-separating mold portions typically defines, or corresponds to, the central circumferential portion of the wheel. During the blow-molding process, a portion of molten plastic is introduced into the mold cavity and a pressurized gas, such as air, is used to force the molten plastic against the internal surface of the cavity in order to form a hollow wheel having a shape defined by the internal surface of the cavity. After a cooling period, the mold portions are separated, and the blow-molded wheel is removed.

Blow-molded articles, including blow-molded wheels, as well as the corresponding molds and processes used to produce such articles, should be configured to permit removal of the finished article from the mold without deforming, tearing, or otherwise damaging the finished article. Projections or hollows on the surface of a blow-molded article typically correspond to hollows or projections on the inner surface of the corresponding mold. Removal of a completed blow-molded article from its mold withdraws the mold projections from hollows on the blow-molded article. Similarly, the projections on the surface of the blow-molded article are removed from the hollows on the inner surface of the mold during mold removal. When such projections or hollows are oriented generally parallel to the direction of mold removal, the projections on the mold or article are simply pulled out of the corresponding hollow during mold removal. In contrast, when the projections or hollows on a blow-molded article are not oriented generally parallel to the direction of mold removal, such as when they are oriented generally perpendicular to the direction of mold removal, such projections or hollows may be said to overlap corresponding portions of the mold with respect to the direction of mold-removal. Blow-molded articles that have projections or hollows that overlap corresponding portions of the mold with respect to the direction of mold-removal are commonly referred to as being "undercut."

Small undercuts may be permissible because blow-molded articles tend to shrink slightly during cooling, such that the article may pull away from the mold and release the overlap. Further, blow-molded articles may permit a small amount of elastic deformation or deflection, which may be sufficient to release

small undercuts. However, undercuts over a certain threshold may effectively lock a blow-molded article into its mold. In particular, if an undercut is too large, the shrinkage and/or potential elastic deformation of the blow-molded article may be insufficient to permit removal of the finished article without damage. Conventionally, blow-molded wheels must have undercuts of $\frac{1}{8}$ inch (3.175 millimeters) or less so that they may be removed from the molds used to form the wheels.

As discussed above, blow-molded wheels are typically blown in a mold that opens in an axial direction. By using a mold that opens in an axial direction, blow-molded wheels may have significant axially oriented projections or hollows, such as may be used to form or detail the hub region of the wheel. However, in order to avoid significant undercuts that might lock a blow-molded wheel into its mold, the design of the tread surface on a blow-molded wheel[s] is typically of limited complexity. In the case of blow-molded wheels used with children's ride-on vehicles, which are often intended to resemble full-sized vehicles, the limited complexity of the tread designs typically provided on blow-molded wheels limits the realism of the blow-molded wheels, which are often intended to resemble rubber tires.

7. The term "undercut," as used in the preceding paragraph 6, also may be described as a "predetermined threshold" of the difference of the radial distance to a first portion of a blow-molded wheel's tread surface and the radial distance to a second portion of the wheel's tread surface, with the second portion of the tread surface being positioned between the first portion and the part-line of the blow-molded wheel, as described in the '421 application.

8. Blow-molded wheels of children's ride-on vehicles often have diameters in the range of 11–15 inches.

9. Using the technology for blow-molding wheel bodies for children's ride-on vehicles that was available prior to the conception of the inventive subject matter of the '421 application, the degree of permissible undercut for a tread surface of a blow-molded wheel was a function of the diameter of the wheel.

10. To the best of my knowledge, prior to the conception of the inventive subject matter of the '421 application, blow-molded wheel bodies for children's ride-on vehicles did not exist that included tread surfaces having undercuts greater than the larger of 1/8 inch and 0.1% of the wheel's diameter. To the best of my knowledge, prior to the conception of the inventive subject matter of the '421 application, manufacturers of blow-molded wheel bodies of children's ride-on vehicles were limited to designing and producing wheel bodies having tread surfaces with undercuts less than 1/8 inch and/or less than 0.1% of a typical children's ride-on vehicle wheel's diameter.

11. I believe that the limits on the possible undercut depth are due to limitations in known blow-molding processes prior to the conception of the inventive subject matter of the '421 application. Specifically, it was not possible to produce a blow-molded wheel with a tread surface having a greater undercut because the blow-molded wheel could not be removed from the mold without being destroyed or otherwise rendered unusable.

12. Due to the limitations of the technology of blow-molded wheel bodies for children's ride-on vehicles prior to the conception of the inventive subject matter of the '421 application, it would not have been obvious to produce a blow-molded wheel body having a tread surface with an undercut greater than the larger of 1/8 inch and 0.1% of the wheel's diameter. In other words, producing a blow-molded wheel with a tread surface having such an undercut was not an obvious or available design choice because such wheels could not be produced using conventional blow-molding processes.

U.S. Patent No. 5,924,506

13. I have read and am familiar with U.S. Patent No. 5,924,506 to Perego (the "506 patent").

14. The '506 patent does not discuss the process by which the illustrated wheel is produced. I believe that the illustrated wheel was likely produced by a blow-molding process. The illustrated wheel does not have a tread surface with an undercut that is equal to, much less greater than, 0.1% of the wheel's diameter. Assuming the illustrated wheel is of a size typically used on children's ride-on vehicles (e.g., having a diameter in the 11–15 inch range), the illustrated undercut of the tread surface would not have been greater than 1/8 inch. In view of this, I believe the illustrated wheel, with the depicted tread surface, could have been produced with a conventional blow-molding process, such as existed prior to conception of the inventive subject matter of the '451 application.

15. Having knowledge of the state of the technology of blow-molding wheels for children's ride-on vehicles prior to the conception of the inventive subject matter of the '421 application, I do not believe that a version of the illustrated wheel having a tread pattern with an undercut that is greater than the larger of 1/8 inch and 0.1% of the wheel's diameter could have been produced. Moreover, the '506 patent would not have led me to design and produce a blow-molded wheel for a children's ride-on vehicle having a tread surface undercut greater than the larger of 1/8 inch and 0.1% of the wheel's diameter.

Statement Under 18 U.S.C. § 1001

16. I hereby declare that all statements made herein of my own knowledge are true and that statements made on information and belief are believed to be true, and further that these statements were made with the knowledge that willful false statements and the like so made are punishable by fine or imprisonment, or both, under Section 1001 of Title 18 of the United States Code and that such willful false statements may jeopardize the validity of the application of any patent issued thereon.

Date: 6/12/09

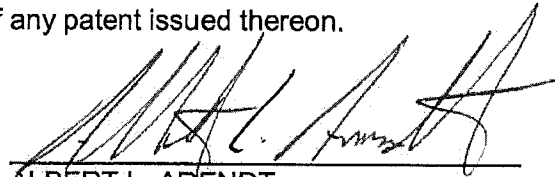
ALBERT L. ARENDT

Electronic Acknowledgement Receipt

EFS ID:	11948808
Application Number:	13103310
International Application Number:	
Confirmation Number:	9050
Title of Invention:	BLOW-MOLDED WHEELS HAVING UNDERCUT TREADS, METHODS FOR PRODUCING THE SAME, AND CHILDREN'S RIDE-ON VEHICLES INCLUDING THE SAME
First Named Inventor/Applicant Name:	Albert L. Arendt
Correspondence Address:	David S. D'Ascenzo DASCENZO INTELLECTUAL PROPERTY LAW, P.C. Suite 925 522 S.W. 5th Avenue Portland OR 97204 US 5032247529 david@dascenzoiplaw.com
Filer:	David S. D'Ascenzo/Robin Davin
Filer Authorized By:	David S. D'Ascenzo
Attorney Docket Number:	MPW 3M1B
Receipt Date:	30-JAN-2012
Filing Date:	09-MAY-2011
Time Stamp:	12:26:30
Application Type:	Utility under 35 USC 111(a)

Payment information:

Submitted with Payment	no
------------------------	----

File Listing:

Document Number	Document Description	File Name	File Size(Bytes)/ Message Digest	Multi Part /.zip	Pages (if appl.)
1		Amendment_and_Response_t o_Office_action_MPW3M1B_1- 30-12.pdf	174053 fe03ec6b441c44301087b7cc48dc5655853 5ab2f	yes	15
Multipart Description/PDF files in .zip description					
Document Description			Start	End	
Amendment/Req. Reconsideration-After Non-Final Reject			1	1	
Specification			2	3	
Claims			4	9	
Drawings-only black and white line drawings			10	10	
Applicant Arguments/Remarks Made in an Amendment			11	15	
Warnings:					
Information:					
2	Drawings-only black and white line drawings	Replacement_Drawing_Sheet_ 3_MPW3M1B_1-30-12.pdf	52192 e8b26d9f430707bb4f94b10020828e65168 c3942	no	1
Warnings:					
Information:					
3	Oath or Declaration filed	Declaration_of_Albert_L_Aren dt_MPW3M1B_1-30-12.pdf	574565 842c8f02c7a228974e4771cb596fa1120504 30c2	no	6
Warnings:					
Information:					
Total Files Size (in bytes):			800810		

This Acknowledgement Receipt evidences receipt on the noted date by the USPTO of the indicated documents, characterized by the applicant, and including page counts, where applicable. It serves as evidence of receipt similar to a Post Card, as described in MPEP 503.

New Applications Under 35 U.S.C. 111

If a new application is being filed and the application includes the necessary components for a filing date (see 37 CFR 1.53(b)-(d) and MPEP 506), a Filing Receipt (37 CFR 1.54) will be issued in due course and the date shown on this Acknowledgement Receipt will establish the filing date of the application.

National Stage of an International Application under 35 U.S.C. 371

If a timely submission to enter the national stage of an international application is compliant with the conditions of 35 U.S.C. 371 and other applicable requirements a Form PCT/DO/EO/903 indicating acceptance of the application as a national stage submission under 35 U.S.C. 371 will be issued in addition to the Filing Receipt, in due course.

New International Application Filed with the USPTO as a Receiving Office

If a new international application is being filed and the international application includes the necessary components for an international filing date (see PCT Article 11 and MPEP 1810), a Notification of the International Application Number and of the International Filing Date (Form PCT/RO/105) will be issued in due course, subject to prescriptions concerning national security, and the date shown on this Acknowledgement Receipt will establish the international filing date of the application.

Under the Paperwork Reduction Act of 1995, no persons are required to respond to a collection of information unless it displays a valid OMB control number.

PATENT APPLICATION FEE DETERMINATION RECORD Substitute for Form PTO-875	Application or Docket Number 13/103,310	Filing Date 05/09/2011	<input type="checkbox"/> To be Mailed
---	---	----------------------------------	---------------------------------------

APPLICATION AS FILED – PART I			OTHER THAN SMALL ENTITY			
	(Column 1)	(Column 2)	SMALL ENTITY <input type="checkbox"/>	OR	SMALL ENTITY	
FOR	NUMBER FILED	NUMBER EXTRA	RATE (\$)	FEE (\$)	RATE (\$)	FEE (\$)
<input type="checkbox"/> BASIC FEE <small>(37 CFR 1.16(a), (b), or (c))</small>	N/A	N/A	N/A		N/A	
<input type="checkbox"/> SEARCH FEE <small>(37 CFR 1.16(k), (j), or (m))</small>	N/A	N/A	N/A		N/A	
<input type="checkbox"/> EXAMINATION FEE <small>(37 CFR 1.16(o), (p), or (q))</small>	N/A	N/A	N/A		N/A	
TOTAL CLAIMS <small>(37 CFR 1.16(j))</small>	minus 20 =	*	X \$ =	OR	X \$ =	
INDEPENDENT CLAIMS <small>(37 CFR 1.16(h))</small>	minus 3 =	*	X \$ =		X \$ =	
<input type="checkbox"/> APPLICATION SIZE FEE <small>(37 CFR 1.16(s))</small>	If the specification and drawings exceed 100 sheets of paper, the application size fee due is \$250 (\$125 for small entity) for each additional 50 sheets or fraction thereof. See 35 U.S.C. 41(a)(1)(G) and 37 CFR 1.16(s).					
<input type="checkbox"/> MULTIPLE DEPENDENT CLAIM PRESENT <small>(37 CFR 1.16(j))</small>						
* If the difference in column 1 is less than zero, enter "0" in column 2.			TOTAL		TOTAL	

APPLICATION AS AMENDED – PART II					OTHER THAN SMALL ENTITY			
	(Column 1)	(Column 2)	(Column 3)		SMALL ENTITY	OR	SMALL ENTITY	
AMENDMENT	01/30/2012	CLAIMS REMAINING AFTER AMENDMENT	HIGHEST NUMBER PREVIOUSLY PAID FOR	PRESENT EXTRA	RATE (\$)	ADDITIONAL FEE (\$)	RATE (\$)	ADDITIONAL FEE (\$)
	Total (37 CFR 1.16(i))	* 20	Minus ** 20	= 0	X \$ =		OR	X \$60= 0
	Independent (37 CFR 1.16(h))	* 2	Minus ***3	= 0	X \$ =		OR	X \$250= 0
	<input type="checkbox"/> Application Size Fee (37 CFR 1.16(s))						OR	
	<input type="checkbox"/> FIRST PRESENTATION OF MULTIPLE DEPENDENT CLAIM (37 CFR 1.16(j))						OR	
					TOTAL ADD'L FEE		OR	TOTAL ADD'L FEE
							OR	0

	(Column 1)	(Column 2)	(Column 3)		SMALL ENTITY	OR	SMALL ENTITY	
AMENDMENT		CLAIMS REMAINING AFTER AMENDMENT	HIGHEST NUMBER PREVIOUSLY PAID FOR	PRESENT EXTRA	RATE (\$)	ADDITIONAL FEE (\$)	RATE (\$)	ADDITIONAL FEE (\$)
	Total (37 CFR 1.16(i))	*	Minus **	=	X \$ =		OR	X \$ =
	Independent (37 CFR 1.16(h))	*	Minus ***	=	X \$ =		OR	X \$ =
	<input type="checkbox"/> Application Size Fee (37 CFR 1.16(s))						OR	
	<input type="checkbox"/> FIRST PRESENTATION OF MULTIPLE DEPENDENT CLAIM (37 CFR 1.16(j))						OR	
					TOTAL ADD'L FEE		OR	TOTAL ADD'L FEE
							OR	

* If the entry in column 1 is less than the entry in column 2, write "0" in column 3.
 ** If the "Highest Number Previously Paid For" IN THIS SPACE is less than 20, enter "20".
 *** If the "Highest Number Previously Paid For" IN THIS SPACE is less than 3, enter "3".
 The "Highest Number Previously Paid For" (Total or Independent) is the highest number found in the appropriate box in column 1.

Legal Instrument Examiner:
 /SHIRELL M. CARMICHAEL/

This collection of information is required by 37 CFR 1.16. The information is required to obtain or retain a benefit by the public which is to file (and by the USPTO to process) an application. Confidentiality is governed by 35 U.S.C. 122 and 37 CFR 1.14. This collection is estimated to take 12 minutes to complete, including gathering, preparing, and submitting the completed application form to the USPTO. Time will vary depending upon the individual case. Any comments on the amount of time you require to complete this form and/or suggestions for reducing this burden, should be sent to the Chief Information Officer, U.S. Patent and Trademark Office, U.S. Department of Commerce, P.O. Box 1450, Alexandria, VA 22313-1450. DO NOT SEND FEES OR COMPLETED FORMS TO THIS ADDRESS. **SEND TO: Commissioner for Patents, P.O. Box 1450, Alexandria, VA 22313-1450.**

If you need assistance in completing the form, call 1-800-PTO-9199 and select option 2.



UNITED STATES PATENT AND TRADEMARK OFFICE

UNITED STATES DEPARTMENT OF COMMERCE
United States Patent and Trademark Office
Address: COMMISSIONER FOR PATENTS
P.O. Box 1450
Alexandria, Virginia 22313-1450
www.uspto.gov

APPLICATION NO.	FILING DATE	FIRST NAMED INVENTOR	ATTORNEY DOCKET NO.	CONFIRMATION NO.
13/103,310	05/09/2011	Albert L. Arendt	MPW 3MIB	9050
	7590	04/17/2012	EXAMINER	
David S. D'Ascenzo DASCENZO INTELLECTUAL PROPERTY LAW, P.C. Suite 925 522 S.W. 5th Avenue Portland, OR 97204			STABLEY, MICHAEL R	
			ART UNIT	PAPER NUMBER
			3611	
			MAIL DATE	DELIVERY MODE
			04/17/2012	PAPER

Please find below and/or attached an Office communication concerning this application or proceeding.

The time period for reply, if any, is set in the attached communication.

DETAILED ACTION

Claim Rejections - 35 USC § 103

1. The following is a quotation of 35 U.S.C. 103(a) which forms the basis for all obviousness rejections set forth in this Office action:

(a) A patent may not be obtained though the invention is not identically disclosed or described as set forth in section 102 of this title, if the differences between the subject matter sought to be patented and the prior art are such that the subject matter as a whole would have been obvious at the time the invention was made to a person having ordinary skill in the art to which said subject matter pertains. Patentability shall not be negated by the manner in which the invention was made.

2. Claims 1-8, 18, and 19 rejected under 35 U.S.C. 103(a) as being unpatentable over Damon (US 2005/0056474) in view of Gallizia (U.S. 4,088,523).

In re claim 1, Damon discloses a children's ride-on vehicle (10), comprising: a vehicle body (12) having at least one seat sized for a child; a plurality of wheels rotatably coupled to the vehicle body, wherein the plurality of wheels includes at least one driven wheel (36, 38) and at least one steerable wheel (32, 34), wherein at least one of the plurality of wheels is a blow-molded wheel that comprises a blow-molded wheel body having a diameter, an outer surface, first and second sidewalls, a central circumference, and an axis, wherein the blow-molded wheel body is configured to rotate about the axis, wherein the outer surface and the central circumference extend circumferentially around the blow-molded wheel body and between the first and second sidewalls, and wherein the central circumference is equidistant from the first and second sidewalls; a first region of the outer surface, wherein the first region is disposed between the first sidewall and the central circumference of the blow-molded wheel body; a second region of the outer surface, wherein the second region is disposed between the second sidewall and the central circumference of the blow-molded wheel body; but

Art Unit: 3611

does not disclose a recessed region between the first region and the second region, wherein the first region and the second region are directly adjacent to the recessed region, and wherein a first radial distance from the axis to the first region and a second radial distance from the axis to the second region both exceed a third radial distance from the axis to the recessed region by at least the larger of 1/8 inch and 0.1% of the diameter. Gallizia, however, does disclose a first region (1) of the outer surface, wherein the first region is disposed between the first sidewall (8') and the central circumference of the blow-molded wheel body; a second region (left equivalent of 1) of the outer surface, wherein the second region is disposed between the second sidewall (8) and the central circumference of the molded wheel body; and a recessed region (center of tread) between the first region and the second region, wherein the first region and the second region are directly adjacent to the recessed region, and wherein a first radial distance from the axis to the first region and a second radial distance from the axis to the second region both exceed a third radial distance from the axis to the recessed region by at least the larger of 1/8 inch and 0.1% of the diameter as shown in Figure 1. It would have been obvious to one having ordinary skill in the art at the time the invention was made to modify the wheel of Damon such that it comprised the tread pattern of Gallizia to support the vehicle and provide improved traction.

In re claim 2, Gallizia further discloses wherein the recessed region coincides with the central circumference as shown in Figure 1.

In re claim 3, Gallizia further discloses wherein the recessed region overlaps the central circumference as shown in Figure 1.

In re claim 4, Gallizia further discloses wherein the blow-molded wheel body has a part line, and wherein the recessed region coincides with the part line as shown in Figure 1.

In re claim 5, Gallizia further discloses wherein the blow-molded wheel body has a part line, wherein the central circumference coincides with the part line, and wherein the recessed region overlaps the central circumference as shown in Figure 1.

In re claim 6, Gallizia further discloses wherein the first region and the second region of the outer surface are smooth around an entire circumference of the blow-molded wheel body as shown in Figure 1.

In re claim 7, Gallizia further discloses wherein the first radial distance and the second radial distance are generally constant around an entire circumference of the blow-molded wheel body as shown in Figure 1.

In re claim 8, Gallizia further discloses wherein the first region and the second region of the outer surface are substantially smooth around an entire circumference of the blow-molded wheel body as shown in Figure 1.

In re claim 18, Gallizia further discloses wherein the recessed region defines a channel having a generally rectangular cross-section and extending around an entire circumference of the blow-molded wheel body as shown in Figures 1 and 3.

In re claim 19, Gallizia further discloses wherein the channel extends around the central circumference of the blow-molded wheel body as shown in Figure 1.

Art Unit: 3611

Allowable Subject Matter

3. Claims 9-17 objected to as being dependent upon a rejected base claim, but would be allowable if rewritten in independent form including all of the limitations of the base claim and any intervening claims.

The following is a statement of reasons for the indication of allowable subject matter: The specific limitations of “further comprises a third region of the outer surface, wherein the third region is disposed between the first sidewall and the first region; and a fourth region of the outer surface, wherein the fourth region is disposed between the second sidewall and the second region; wherein the third region and the fourth region include a plurality of tread blocks on the outer surface, wherein the plurality of tread blocks are separated and spaced apart from each other on the outer surface” is not anticipated or made obvious by the prior art of record in the examiner’s opinion.

4. Claim 20 allowed.

The following is a statement of reasons for the indication of allowable subject matter: The specific limitations of “a third region of the outer surface, wherein the third region is disposed between the first sidewall and the first region, and wherein the third region includes a plurality of spaced-apart tread blocks on the outer surface; and a fourth region of the outer surface, wherein the fourth region is disposed between the second sidewall and the second region, and wherein fourth region includes a plurality of spaced-apart tread blocks on the outer surface” is not anticipated or made obvious by the prior art of record in the examiner’s opinion.

Response to Arguments

3. Applicant's arguments, filed 1/30/12, with respect to the rejection(s) of claim(s) 1-8, 18, and 19 under 103 have been fully considered and are persuasive. Therefore, the rejection has been withdrawn. However, upon further consideration, a new ground(s) of rejection is made as described above.

Conclusion

Any inquiry concerning this communication or earlier communications from the examiner should be directed to MICHAEL STABLEY whose telephone number is (571)270-3249. The examiner can normally be reached on M-F 9-5:30.

If attempts to reach the examiner by telephone are unsuccessful, the examiner's supervisor, Lesley D. Morris can be reached on 571-272-6651. The fax phone number for the organization where this application or proceeding is assigned is 571-273-8300.

Art Unit: 3611

Information regarding the status of an application may be obtained from the Patent Application Information Retrieval (PAIR) system. Status information for published applications may be obtained from either Private PAIR or Public PAIR. Status information for unpublished applications is available through Private PAIR only. For more information about the PAIR system, see <http://pair-direct.uspto.gov>. Should you have questions on access to the Private PAIR system, contact the Electronic Business Center (EBC) at 866-217-9197 (toll-free). If you would like assistance from a USPTO Customer Service Representative or access to the automated information system, call 800-786-9199 (IN USA OR CANADA) or 571-272-1000.

/Michael R Stabley/
Examiner, Art Unit 3611

/LESLEY D. MORRIS/

Supervisory Patent Examiner, Art Unit 3611

Notice of References Cited	Application/Control No. 13/103,310	Applicant(s)/Patent Under Reexamination ARENDE ET AL.	
	Examiner MICHAEL STABLEY	Art Unit 3611	Page 1 of 1

U.S. PATENT DOCUMENTS

*	Document Number Country Code-Number-Kind Code	Date MM-YYYY	Name	Classification
*	A US-4,088,523 A	05-1978	Gallizia et al.	156/125
*	B US-2009/0108666 A1	04-2009	Kashiwai et al.	301/95.104
	C US-			
	D US-			
	E US-			
	F US-			
	G US-			
	H US-			
	I US-			
	J US-			
	K US-			
	L US-			
	M US-			

FOREIGN PATENT DOCUMENTS

*	Document Number Country Code-Number-Kind Code	Date MM-YYYY	Country	Name	Classification
	N				
	O				
	P				
	Q				
	R				
	S				
	T				

NON-PATENT DOCUMENTS

*	Document Number Country Code-Number-Kind Code	Date MM-YYYY	Country	Name	Classification
	Include as applicable: Author, Title Date, Publisher, Edition or Volume, Pertinent Pages)				
	U				
	V				
	W				
	X				

*A copy of this reference is not being furnished with this Office action. (See MPEP § 707.05(a).)
Dates in MM-YYYY format are publication dates. Classifications may be US or foreign.

EAST Search History

EAST Search History (Prior Art)

Ref #	Hits	Search Query	DBs	Default Operator	Plurals	Time Stamp
S1	67	("2601700" "20030085611" "20040070262" "20050056474" "3029468" "3264780" "3373460" "3592885" "3616491" "3692453" "3730658" "3779688" "3817676" "3851029" "3888545" "3907370" "3936264" "3135997" "3570057" "4063868" "4323411" "4513981" "4531704" "4588842" "4717113" "4832307" "4854849" "4884961" "4889480" "4516648" "5104198" "5219594" "5227114" "5316135" "5316377" "5368371" "5518682" "5556601" "5573129" "5736168" "5750067" "5799809" "5810452" "5908124" "5924506" "6068161" "6095543" "6170920" "6318983" "6431406" "6464305" "6520597" "6591986" "6872354" "6896335" "6913324" "6953333" "6470982").PN.	US-PGPUB; USPAT; USOCR	OR	ON	2009/01/28 11:16
S3	14	("3730594" "3894776" "4358162" "5104198" "5368371").PN. OR ("6170920").URPN.	US-PGPUB; USPAT; USOCR	OR	ON	2009/01/28 15:14
S4	325	(tire or wheel) near5 (blow adj mold\$3)	US-PGPUB; USPAT; USOCR	OR	ON	2009/01/28 15:23
S5	14	("3870372" "3960474" "4040670" "4088523" "4301850" "4722131" "5104198" "5114522" "5133591").PN. OR ("5518682").URPN.	US-PGPUB; USPAT; USOCR	OR	ON	2009/01/28 16:19
S6	18	("1560551" "1687113" "2969254" "3387894" "3870372" "4592595" "5104198" "5129709").PN. OR ("5316377").URPN.	US-PGPUB; USPAT; USOCR	OR	ON	2009/01/28 16:27
S7	14	("3870372" "3960474" "4040670" "4088523" "4301850" "4722131" "5104198" "5114522" "5133591").PN. OR ("5518682").URPN.	US-PGPUB; USPAT; USOCR	OR	ON	2009/03/20 14:14
S8	18	("1560551" "1687113" "2969254" "3387894" "3870372" "4592595" "5104198" "5129709").PN. OR ("5316377").URPN.	US-PGPUB; USPAT; USOCR	OR	ON	2009/03/20 14:15
S9	1277	280/29.ccls. or 264/454.ccls. or 152/209.1.ccls.	US-PGPUB; USPAT; USOCR	OR	ON	2009/08/03 15:49
S10	674	152/209.1.ccls.	US-PGPUB;	OR	ON	2009/08/03 15:50

			USPAT; USOCR			
S12	72	("2601700" "20030085611" "20040070262" "20050056474" "20080006456" "3029468" "3135997" "3264780" "3373460" "3570057" "3592885" "3616491" "3692453" "3730658" "3779688" "3817676" "3851029" "3888545" "3907370" "3936264" "4063868" "4323411" "4513981" "4516648" "4531704" "4588542" "4717113" "4832307" "4854849" "4884961" "4889480" "5104198" "5219594" "5227114" "5316135" "5316377" "5368371" "5518682" "5556601" "5573129" "5736168" "5750067" "5799809" "5810452" "5879484" "5908124" "5924506" "6068161" "6095543" "6170920" "6318983" "6431406" "6446981" "6464305" "6470982" "6520597" "6591986" "6872354" "6896335" "6913324" "6953333" "7621543" "D327048").PN.	US- PGPUB; USPAT; USOCR	OR	ON	2011/10/23 12:17
S13	1411	280/29.ccls. or 264/454.ccls. or 152/209.1.ccls.	US- PGPUB; USPAT; USOCR	OR	ON	2011/10/23 12:17
S14	1650	264/501.ccls. or 264/512.ccls. or 264/523.ccls. or 264/524.ccls.	US- PGPUB; USPAT; USOCR	OR	ON	2011/10/23 12:19
S15	1650	264/501.ccls. or 264/512.ccls. or 264/523.ccls. or 264/524.ccls.	US- PGPUB; USPAT; USOCR	OR	ON	2011/10/24 10:00
S16	680	S15 and (blow adj mold\$3)	US- PGPUB; USPAT; USOCR	OR	ON	2011/10/24 10:00
S17	39	S15 and ((blow adj mold\$3) same (tire or wheel))	US- PGPUB; USPAT; USOCR	OR	ON	2011/10/24 10:01
S18	35	("1560551" "1687113" "2969254" "3387894" "3870372" "3960474" "4040670" "4088523" "4301850" "4592595" "4722131" "5104198" "5114522" "5129709" "5133591").PN. OR ("5316377" "5518682").URPN.	US- PGPUB; USPAT; USOCR	OR	ON	2011/10/24 17:08
S19	11	(US-20050056474-\$).did. or (US-6464305-\$ or US-6170920-\$ or US-5924506-\$ or US- 5368371-\$ or US-6446981-\$ or US-5518682-\$ or US-5316377-\$ or US-D327048-\$ or US- 5104198-\$ or US-4088523-\$).did.	US- PGPUB; USPAT	OR	ON	2011/10/24 20:02
S20	72	("2601700" "20030085611" "20040070262" "20050056474" "20080006456" "3029468" "3135997" "3264780" "3373460" "3570057" "3592885" "3616491" "3692453" "3730658" "3779688" "3817676" "3851029"	US- PGPUB; USPAT; USOCR	OR	ON	2011/10/24 20:03

		"3888545" "3907370" "3936264" "4063868" "4323411" "4513981" "4516648" "4531704" "4588542" "4717113" "4832307" "4854849" "4884961" "4889480" "5104198" "5219594" "5227114" "5316135" "5316377" "5368371" "5518682" "5556601" "5573129" "5736168" "5750067" "5799809" "5810452" "5879484" "5908124" "5924506" "6068161" "6095543" "6170920" "6318983" "6431406" "6446981" "6464305" "6470982" "6520597" "6591986" "6872354" "6896335" "6913324" "6953333" "7621543" "D327048").PN.				
S21	1	S19 not S20	US- PGPUB; USPAT; USOCR	OR	ON	2011/10/24 20:03
S22	8	(tire or wheel) same (blow adj mold\$3) and (tread adj blocks)	US- PGPUB; USPAT; USOCR	OR	ON	2011/10/25 10:45
S23	72	("20030085611" "20040070262" "20050056474" "20080006456" "2601700" "3029468" "3135997" "3264780" "3373460" "3570057" "3592885" "3616491" "3692453" "3730658" "3779688" "3817676" "3851029" "3888545" "3907370" "3936264" "4063868" "4323411" "4513981" "4516648" "4531704" "4588542" "4717113" "4832307" "4854849" "4884961" "4889480" "5104198" "5219594" "5227114" "5316135" "5316377" "5368371" "5518682" "5556601" "5573129" "5736168" "5750067" "5799809" "5810452" "5879484" "5908124" "5924506" "6068161" "6095543" "6170920" "6318983" "6431406" "6446981" "6464305" "6470982" "6520597" "6591986" "6872354" "6896335" "6913324" "6953333" "7621543" "D327048").PN. OR ("7939008").URPN.	US- PGPUB; USPAT; USOCR	OR	ON	2011/10/25 10:57
S24	1687	264/501.ccls. or 264/512.ccls. or 264/523.ccls. or 264/524.ccls.	US- PGPUB; USPAT; USOCR	OR	ON	2012/04/10 10:04
S25	1435	280/29.ccls. or 264/454.ccls. or 152/209.1.ccls.	US- PGPUB; USPAT; USOCR	OR	ON	2012/04/10 10:04
S26	772	152/209.1.ccls.	US- PGPUB; USPAT; USOCR	OR	ON	2012/04/10 10:04
S27	429	(tire or wheel) near5 (blow adj mold\$3)	US- PGPUB; USPAT; USOCR	OR	ON	2012/04/10 10:50

S28	80	S27 and child\$3	US-PGPUB; USPAT; USOCR	OR	ON	2012/04/10 10:50
S29	58	(tire or wheel) near5 (blow adj mould\$3)	US-PGPUB; USPAT; USOCR	OR	ON	2012/04/10 11:00
S30	2	S29 and child\$3	US-PGPUB; USPAT; USOCR	OR	ON	2012/04/10 11:00
S31	344	(tire or wheel) near3 (blow adj mold\$3)	US-PGPUB; USPAT; USOCR	OR	ON	2012/04/10 11:28
S32	288	S31 not S28	US-PGPUB; USPAT; USOCR	OR	ON	2012/04/10 11:29
S33	34	S32 and (vehicle or car or toy)	US-PGPUB; USPAT; USOCR	OR	ON	2012/04/10 11:30
S34	9	("3264780").URPN.	USPAT	OR	OFF	2012/04/10 11:34
S35	79	("1930835" "20030085611" "20040070262" "20050056474" "20060073289" "20060231303" "20080006456" "2601700" "3029468" "3135997" "3264780" "3373460" "3570057" "3592885" "3616491" "3692453" "3730658" "3779688" "3817676" "3851029" "3888545" "3907370" "3936264" "4063868" "4323411" "4513981" "4516648" "4531704" "4588542" "4717113" "4832307" "4854849" "4884961" "4889480" "5104198" "5219594" "5227114" "5316135" "5316377" "5368371" "5518682" "5553878" "5556601" "5573129" "5736168" "5750067" "5799809" "5810452" "5879484" "5908124" "5924506" "6068161" "6095543" "6170920" "6318983" "6431406" "6446981" "6464305" "6470982" "6520597" "6591986" "6615885" "6872354" "6896335" "6913324" "6953333" "7621543" "D327048").PN. OR ("7621543" "7905305" "7939008").URPN.	US-PGPUB; USPAT; USOCR	OR	OFF	2012/04/10 11:35
S36	72	("20030085611" "20040070262" "20050056474" "20080006456" "2601700" "3029468" "3135997" "3264780" "3373460" "3570057" "3592885" "3616491" "3692453" "3730658" "3779688" "3817676" "3851029" "3888545" "3907370" "3936264" "4063868" "4323411" "4513981" "4516648" "4531704" "4588542" "4717113" "4832307" "4854849" "4884961" "4889480" "5104198"	US-PGPUB; USPAT; USOCR	OR	OFF	2012/04/10 11:37

"5219594"	"5227114"	"5316135"			
"5316377"	"5368371"	"5518682"			
"5556601"	"5573129"	"5736168"			
"5750067"	"5799809"	"5810452"			
"5879484"	"5908124"	"5924506"			
"6068161"	"6095543"	"6170920"			
"6318983"	"6431406"	"6446981"			
"6464305"	"6470982"	"6520597"			
"6591986"	"6872354"	"6896335"			
"6913324"	"6953333"	"7621543"			
"D327048").PN.	OR ("7939008").URPN.				

EAST Search History (Interference)

Ref #	Hits	Search Query	DBs	Default Operator	Plurals	Time Stamp
S11	0	(vehicle and body and wheels and molded and tread and surface and region and radial and distance and steering and assembly and drive).clm.	USPAT; UPAD	OR	ON	2009/08/03 16:05

4/ 10/ 2012 1:27:51 PM

C:\Users\mstabley\Documents\EAST\Workspaces\13103310.wsp

Search Notes 	Application/Control No. 13103310	Applicant(s)/Patent Under Reexamination ARENDR ET AL.
	Examiner MICHAEL STABLEY	Art Unit 3611

SEARCHED			
Class	Subclass	Date	Examiner
280	29	4/10/2012	MS
264	454, 501, 512, 523, 524	4/10/2012	MS
152	209.1	4/10/2012	MS

SEARCH NOTES		
Search Notes	Date	Examiner
EAST Search Results - See Attached	4/10/2012	MS

INTERFERENCE SEARCH			
Class	Subclass	Date	Examiner

/MICHAEL STABLEY/ Examiner.Art Unit 3611	
---	--

IN THE UNITED STATES PATENT AND TRADEMARK OFFICE

June 19, 2012

In re Application of:

ALBERT L. ARENDT, JAMES R. CARDUCCI, and CHRISTOPHER F. LUCAS

Serial No. : 13/103,310 Group Art Unit: 3611

Filed : May 9, 2011 Examiner: Michael R. Stabley

For : BLOW-MOLDED WHEELS HAVING UNDERCUT TREADS,
METHODS FOR PRODUCING THE SAME, AND CHILDREN'S
RIDE-ON VEHICLES INCLUDING THE SAME

Mail Stop AMENDMENT

Commissioner for Patents

PO Box 1450

Alexandria, Virginia 22313-1450

RESPONSE TO OFFICE ACTION

In response to the Office action dated April 17, 2012, please consider the following remarks.

Listing of Claims	Begins on page 2.
Remarks	Begin on page 8.

CLAIM LISTING

This listing of claims reflects all claim amendments and replaces all prior versions, and listings, of claims in the application.

1. (Original) A children's ride-on vehicle, comprising:

a vehicle body having at least one seat sized for a child;

a plurality of wheels rotatably coupled to the vehicle body, wherein the plurality of wheels includes at least one driven wheel and at least one steerable wheel, wherein at least one of the plurality of wheels is a blow-molded wheel that comprises:

a blow-molded wheel body having a diameter, an outer surface, first and second sidewalls, a central circumference, and an axis, wherein the blow-molded wheel body is configured to rotate about the axis, wherein the outer surface and the central circumference extend circumferentially around the blow-molded wheel body and between the first and second sidewalls, and wherein the central circumference is equidistant from the first and second sidewalls;

a first region of the outer surface, wherein the first region is disposed between the first sidewall and the central circumference of the blow-molded wheel body;

a second region of the outer surface, wherein the second region is disposed between the second sidewall and the central circumference of the blow-molded wheel body; and

a recessed region between the first region and the second region, wherein the first region and the second region are directly adjacent to the recessed region, and wherein a first radial distance from the axis to the first region and a second radial distance from the axis to the

second region both exceed a third radial distance from the axis to the recessed region by at least the larger of 1/8 inch and 0.1% of the diameter.

2. (Original) The children's ride-on vehicle of claim 1, wherein the recessed region coincides with the central circumference.

3. (Original) The children's ride-on vehicle of claim 1, wherein the recessed region overlaps the central circumference.

4. (Original) The children's ride-on vehicle of claim 1, wherein the blow-molded wheel body has a part line, and wherein the recessed region coincides with the part line.

5. (Original) The children's ride-on vehicle of claim 1, wherein the blow-molded wheel body has a part line, wherein the central circumference coincides with the part line, and wherein the recessed region overlaps the central circumference.

6. (Original) The children's ride-on vehicle of claim 1, wherein the first region and the second region of the outer surface are smooth around an entire circumference of the blow-molded wheel body.

7. (Original) The children's ride-on vehicle of claim 1, wherein the first radial distance and the second radial distance are generally constant around an entire circumference of the blow-molded wheel body.

8. (Original) The children's ride-on vehicle of claim 1, wherein the first region and the second region of the outer surface are substantially smooth around an entire circumference of the blow-molded wheel body.

9. (Original) The children's ride-on vehicle of claim 8, wherein the blow-molded wheel further comprises:

a third region of the outer surface, wherein the third region is disposed between the first sidewall and the first region; and

a fourth region of the outer surface, wherein the fourth region is disposed between the second sidewall and the second region;

wherein the third region and the fourth region include a plurality of tread blocks on the outer surface, wherein the plurality of tread blocks are separated and spaced apart from each other on the outer surface.

10. (Original) The children's ride-on vehicle of claim 9, wherein at least a subset of the plurality of tread blocks have more than one radial distance from the axis to the respective tread block.

11. (Original) The children's ride-on vehicle of claim 9, wherein at least a portion of the outer surface between the plurality of tread blocks is generally V-shaped.

12. (Original) The children's ride-on vehicle of claim 9, wherein at least a subset of the plurality of tread blocks are generally V-shaped.

13. (Original) The children's ride-on vehicle of claim 9, wherein at least a subset of the plurality of tread blocks are generally U-shaped.

14. (Original) The children's ride-on vehicle of claim 9, wherein at least a subset of the plurality of tread blocks are partially coextensive with the first region and the second region.

15. (Original) The children's ride-on vehicle of claim 9, wherein at least a subset of the plurality of tread blocks extend from an adjacent portion of the outer surface by at least the larger of 1/8 inch and 0.1% of the diameter.

16. (Original) The children's ride-on vehicle of claim 9, wherein at least a subset of the plurality of tread blocks include walls extending from a base surface to define the respective tread blocks, wherein the walls extend at least partially transverse across the outer surface at angles relative to the central circumference.

17. (Original) The children's ride-on vehicle of claim 9, wherein at least a subset of the plurality of tread blocks partially extend onto at least one of the first sidewall and the second sidewall.

18. (Original) The children's ride-on vehicle of claim 1, wherein the recessed region defines a channel having a generally rectangular cross-section and extending around an entire circumference of the blow-molded wheel body.

19. (Original) The children's ride-on vehicle of claim 18, wherein the channel extends around the central circumference of the blow-molded wheel body.

20. (Original) A children's ride-on vehicle, comprising:

a vehicle body having at least one seat sized for a child;

a plurality of wheels rotatably coupled to the vehicle body, wherein the plurality of wheels includes at least one driven wheel and at least one steerable wheel, wherein at least one of the plurality of wheels is a blow-molded wheel that comprises:

a blow-molded wheel body having a diameter, an outer surface, first and second sidewalls, a central circumference, and an axis, wherein the blow-molded wheel body is configured to rotate about the axis, wherein the outer surface and the central circumference extend circumferentially around the blow-molded wheel body and between the first and second sidewalls, and wherein the central circumference is equidistant from the first and second sidewalls;

a first region of the outer surface, wherein the first region is disposed between the first sidewall and the central circumference of the blow-molded wheel body, and wherein the first region is smooth with a first radial distance from the axis to the first region that is generally constant around an entire circumference of the blow-molded wheel body;

a second region of the outer surface, wherein the second region is disposed between the second sidewall and the central circumference of the blow-molded wheel body, and wherein the second region is smooth with a second radial distance from the axis to the second region that is generally constant around an entire circumference of the blow-molded wheel body;

a recessed region between the first region and the second region, wherein the first region and the second region are directly adjacent to the recessed region, and wherein the first radial distance and the second radial distance both exceed a third radial distance from the axis to the recessed region by at least the larger of 1/8 inch and 0.1% of the diameter;

a third region of the outer surface, wherein the third region is disposed between the first sidewall and the first region, and wherein the third region includes a plurality of spaced-apart tread blocks on the outer surface; and

a fourth region of the outer surface, wherein the fourth region is disposed between the second sidewall and the second region, and wherein fourth region includes a plurality of spaced-apart tread blocks on the outer surface.

REMARKS

These remarks are responsive to the Office action mailed on April 17, 2012. In the Office action, the previous rejections were withdrawn, claims 1–8, 18, and 19 were rejected as being obvious over a proposed combination of U.S. Patent Application Publication No. 2005/0056474 to Damon (“Damon”) and U.S. Patent No. 4,088,523 to Gallizia et al. (“Gallizia”), claims 9–17 were indicated to include allowable subject matter, and claim 20 was allowed. Applicants thank the Examiner for withdrawing the prior rejections and for maintaining the indications about the patentability of the subject matter recited in claims 9–17 and 20. Applicants have carefully studied the new rejections of claims 1–8 and 18–19, as well as the references cited to support the rejections. For at least the reasons presented below, Applicants respectfully traverse the new rejections and request reconsideration thereof.

As mentioned, independent claim 1 stands rejected as being obvious over a proposed combination of Damon and Gallizia; however, neither Damon nor Gallizia, nor any permissible combination of the two, discloses, teaches, or even suggests at least the following subject matter of independent claim 1 (with emphasis):

a **blow-molded wheel** ... [with] a recessed region between the first region and the second region ... *wherein a first radial distance from the axis to the first region and a second radial distance from the axis to the second region both exceed a third radial distance from the axis to the recessed region **by at least the larger of 1/8 inch and 0.1% of the diameter.***

The Office action cites to Gallizia for the emphasized subject matter above, which describes a tread pattern having an undercut of a minimum threshold. Specifically, the Office action cites to the structure illustrated in Fig. 1 of Gallizia (reproduced below), equating the recessed region of independent claim 1 to the central channel of the illustrated tread pattern, and

independent claim 1 is improper, and Applicants respectfully request withdrawal of the same. If the Examiner interprets the recitation of “blow-molded” in independent claim 1 as setting forth a product-by-process limitation, Applicants are willing to amend independent claim 1 to set forth definite structure that corresponds to blow-molded parts. Accordingly, at a minimum, Applicants ask the Examiner to consider their position, and if a subsequent Office action is required, Applicants request that the Examiner consider and address this position so that such clarifying amendment may be submitted without requiring a RCE. In this regard, Applicants proactively request that the Examiner contact Applicants’ undersigned attorney if a telephone call and/or proposed Examiner’s amendment is believed to be able to advance prosecution of claims 1–8 and 18–19.

In view of the remarks above, the Examiner may argue that a person of ordinary skill in the art would have been motivated to define the illustrated tread pattern of Gallizia with a blow-molding process to arrive at the subject matter of independent claim 1, such as because Damon discloses blow-molded wheels. Applicants proactively disagree with this position, and again direct the Examiner’s attention to the previously submitted declaration under 37 C.F.R. 1.132 of Albert L. Arendt, with evidence establishing the nonobviousness of the subject matter of independent claim 1. Entry of the declaration was not acknowledged in the Office action, and therefore, Applicants proactively resubmit it again together with this response.

The submitted declaration was originally submitted in connection with co-owned U.S. Patent Application No. 11/509,421, now U.S. Patent No. 7,621,543, from which the present application claims priority. Specifically, in addition to the reasons expressed above, the subject matter of independent claim 1 is not obvious because one of ordinary skill in the art would not have been motivated to attempt to blow-mold a wheel having a recess that is defined by adjacent

regions in which “wherein a first radial distance from the axis to the first region and a second radial distance from the axis to the second region both exceed a third radial distance from the axis to the recessed region *by at least the larger of 1/8 inch and 0.1% of the diameter.*” The recited “recessed region” may be described as defining an “undercut” in the tread pattern.

Mr. Arendt is one of the listed inventors of the present application and an engineer with 25 years of experience with molding components for children’s products, including 10 years of experience with the design and molding, including blow-molding, of wheels for children’s ride-on vehicles. [Arendt Decl. ¶ 3.] Briefly, and without reproducing the entirety of Mr. Arendt’s declaration (which, as mentioned, was originally prepared for submission in the present application’s parent), prior to Applicants’ conception of the inventive subject matter of independent claim 1, only tread patterns having undercuts *less than* 1/8 inch and/or *less than* 0.1% of the wheel’s diameter were possible for typical blow-molded wheel bodies of children’s ride-on vehicles. [See specification, p. 3, lines 8–17 and Arendt Decl., ¶¶ 6–11.] Moreover, blow-molded wheel bodies having thresholds, or undercuts, greater than the larger of 1/8 inch and 0.1% of the wheel’s diameter did not even exist prior to the inventive subject matter of the present application. [Arendt Decl., ¶ 10.] That is, even if one of ordinary skill in the art would have contemplated blow-molded wheel bodies having tread patterns with undercuts greater than the larger of 1/8 inch and 0.1% of the wheel’s diameter, the technology simply did not exist to *enable* such wheel bodies. [See *id.* at ¶¶ 11–12.] In fact, neither of the cited references Damon and Gallizia enable the subject matter of independent claim 1.

Accordingly, it would not have been obvious to one of ordinary skill in the art of blow-molded wheel bodies of children’s ride-on vehicles to provide, let alone attempt to produce, a blow-molded wheel body having a tread pattern with an undercut greater than the larger of

1/8 inch and 0.1% of the wheel's diameter. [See *id.* at ¶ 12.] For at least these additional reasons, independent claim 1 and the claims that depend therefrom are patentable over the prior art, and Applicants respectfully request withdrawal of the rejections of the same.

With the withdrawal of the rejections of claims 1–8 and 18–19, Applicants believe that this application will be in condition for allowance. Applicants therefore respectfully request that the Examiner issue a Notice of Allowance covering all of the pending claims. If the Examiner has any questions, or if a telephone interview would in any way advance prosecution, please contact the undersigned.

CERTIFICATE OF E-FILING

I hereby certify that this correspondence and the attached Declaration of Albert L. Arendt are being transmitted electronically via the United States Patent and Trademark Office's EFS-Web System on June 19, 2012.



David S. D'Ascenzo

Respectfully submitted,

DASCENZO INTELLECTUAL
PROPERTY LAW, P.C.



David S. D'Ascenzo
Registration No. 39,952
Customer No. 78569
DASCENZO INTELLECTUAL
PROPERTY LAW, P.C.
522 S.W. 5th Ave, Suite 925
Portland, Oregon 97204
Telephone: (503) 224-7529
Facsimile: (503) 224-7329

IN THE UNITED STATES PATENT AND TRADEMARK OFFICE

In re Application of:

Albert L. Arendt et al.

Serial No. : 11/509,421

Filed : August 23, 2006

For : BLOW-MOLDED WHEELS HAVING UNDERCUT TREADS,
METHODS FOR PRODUCING THE SAME,
AND CHILDREN'S RIDE-ON VEHICLES INCLUDING THE SAME

DECLARATION OF ALBERT L. ARENDT UNDER 37 C.F.R. 1.132

I, ALBERT L. ARENDT, declare:

General Background

1. I have an associate's degree in Mechanical Technology.
2. I have been working for Fisher-Price, Inc., a division of Mattel, Inc., for approximately 32 years. Mattel, Inc. is the assignee of U.S. Patent Application Serial No. 11/509,421 (the "421 application").
3. I have been involved in the design and production of molded plastic components for children's products for approximately 25 years, including the design of at least 50 different blow-molded parts and the manufacturing thereof. During this time, I have developed substantial experience relating to the design, prototyping, debugging, and production of blow-molded parts, including design, debugging, and operation of the corresponding molds and molding processes. For approximately the last 10 years, I have focused primarily on the design and manufacturing of molded wheels and other parts for children's ride-on vehicles. This molding includes blow molding of such wheels and parts.

4. I currently hold the title of Staff Engineer - Plastics/Tooling.

The 11/509,421 Patent Application

5. I am one of the listed inventors of the '421 application.
6. The following is an excerpt from the Background of the Disclosure section of the '421 application, and which I restate herein:

The wheels used on children's ride-on vehicles are often blow-molded from a suitable material, such as a plastic. Blow-molded wheels are conventionally formed using a mold that has two portions, which typically separate in an axial direction. The portions of the mold collectively define a cavity that defines, or corresponds to, the shape of the blow-molded wheels, including the tread surface. The seam, or part line, between the axially-separating mold portions typically defines, or corresponds to, the central circumferential portion of the wheel. During the blow-molding process, a parison of molten plastic is introduced into the mold cavity and a pressurized gas, such as air, is used to force the molten plastic against the internal surface of the cavity in order to form a hollow wheel having a shape defined by the internal surface of the cavity. After a cooling period, the mold portions are separated, and the blow-molded wheel is removed.

Blow-molded articles, including blow-molded wheels, as well as the corresponding molds and processes used to produce such articles, should be configured to permit removal of the finished article from the mold without deforming, tearing, or otherwise damaging the finished article. Projections or hollows on the surface of a blow-molded article typically correspond to hollows or projections on the inner surface of the corresponding mold. Removal of a completed blow-molded article from its mold withdraws the mold projections from hollows on the blow-molded article. Similarly, the projections on the surface of the blow-molded article are removed from the hollows on the inner surface of the mold during mold removal. When such projections or hollows are oriented generally parallel to the direction of mold removal, the projections on the mold or article are simply pulled out of the corresponding hollow during mold removal. In contrast, when the projections or hollows on a blow-molded article are not oriented generally parallel to the direction of mold removal, such as when they are oriented generally perpendicular to the direction of mold removal, such projections or hollows may be said to overlap corresponding portions of the mold with respect to the direction of mold-removal. Blow-molded articles that have projections or hollows that overlap corresponding portions of the mold with respect to the direction of mold-removal are commonly referred to as being "undercut."

Small undercuts may be permissible because blow-molded articles tend to shrink slightly during cooling, such that the article may pull away from the mold and release the overlap. Further, blow-molded articles may permit a small amount of elastic deformation or deflection, which may be sufficient to release

small undercuts. However, undercuts over a certain threshold may effectively lock a blow-molded article into its mold. In particular, if an undercut is too large, the shrinkage and/or potential elastic deformation of the blow-molded article may be insufficient to permit removal of the finished article without damage. Conventionally, blow-molded wheels must have undercuts of $\frac{1}{8}$ inch (3.175 millimeters) or less so that they may be removed from the molds used to form the wheels.

As discussed above, blow-molded wheels are typically blown in a mold that opens in an axial direction. By using a mold that opens in an axial direction, blow-molded wheels may have significant axially oriented projections or hollows, such as may be used to form or detail the hub region of the wheel. However, in order to avoid significant undercuts that might lock a blow-molded wheel into its mold, the design of the tread surface on a blow-molded wheel[s] is typically of limited complexity. In the case of blow-molded wheels used with children's ride-on vehicles, which are often intended to resemble full-sized vehicles, the limited complexity of the tread designs typically provided on blow-molded wheels limits the realism of the blow-molded wheels, which are often intended to resemble rubber tires.

7. The term "undercut," as used in the preceding paragraph 6, also may be described as a "predetermined threshold" of the difference of the radial distance to a first portion of a blow-molded wheel's tread surface and the radial distance to a second portion of the wheel's tread surface, with the second portion of the tread surface being positioned between the first portion and the part-line of the blow-molded wheel, as described in the '421 application.

8. Blow-molded wheels of children's ride-on vehicles often have diameters in the range of 11–15 inches.

9. Using the technology for blow-molding wheel bodies for children's ride-on vehicles that was available prior to the conception of the inventive subject matter of the '421 application, the degree of permissible undercut for a tread surface of a blow-molded wheel was a function of the diameter of the wheel.

10. To the best of my knowledge, prior to the conception of the inventive subject matter of the '421 application, blow-molded wheel bodies for children's ride-on vehicles did not exist that included tread surfaces having undercuts greater than the larger of 1/8 inch and 0.1% of the wheel's diameter. To the best of my knowledge, prior to the conception of the inventive subject matter of the '421 application, manufacturers of blow-molded wheel bodies of children's ride-on vehicles were limited to designing and producing wheel bodies having tread surfaces with undercuts less than 1/8 inch and/or less than 0.1% of a typical children's ride-on vehicle wheel's diameter.

11. I believe that the limits on the possible undercut depth are due to limitations in known blow-molding processes prior to the conception of the inventive subject matter of the '421 application. Specifically, it was not possible to produce a blow-molded wheel with a tread surface having a greater undercut because the blow-molded wheel could not be removed from the mold without being destroyed or otherwise rendered unusable.

12. Due to the limitations of the technology of blow-molded wheel bodies for children's ride-on vehicles prior to the conception of the inventive subject matter of the '421 application, it would not have been obvious to produce a blow-molded wheel body having a tread surface with an undercut greater than the larger of 1/8 inch and 0.1% of the wheel's diameter. In other words, producing a blow-molded wheel with a tread surface having such an undercut was not an obvious or available design choice because such wheels could not be produced using conventional blow-molding processes.

U.S. Patent No. 5,924,506

13. I have read and am familiar with U.S. Patent No. 5,924,506 to Perego (the "506 patent").

14. The '506 patent does not discuss the process by which the illustrated wheel is produced. I believe that the illustrated wheel was likely produced by a blow-molding process. The illustrated wheel does not have a tread surface with an undercut that is equal to, much less greater than, 0.1% of the wheel's diameter. Assuming the illustrated wheel is of a size typically used on children's ride-on vehicles (e.g., having a diameter in the 11–15 inch range), the illustrated undercut of the tread surface would not have been greater than 1/8 inch. In view of this, I believe the illustrated wheel, with the depicted tread surface, could have been produced with a conventional blow-molding process, such as existed prior to conception of the inventive subject matter of the '451 application.

15. Having knowledge of the state of the technology of blow-molding wheels for children's ride-on vehicles prior to the conception of the inventive subject matter of the '421 application, I do not believe that a version of the illustrated wheel having a tread pattern with an undercut that is greater than the larger of 1/8 inch and 0.1% of the wheel's diameter could have been produced. Moreover, the '506 patent would not have led me to design and produce a blow-molded wheel for a children's ride-on vehicle having a tread surface undercut greater than the larger of 1/8 inch and 0.1% of the wheel's diameter.

Statement Under 18 U.S.C. § 1001

16. I hereby declare that all statements made herein of my own knowledge are true and that statements made on information and belief are believed to be true, and further that these statements were made with the knowledge that willful false statements and the like so made are punishable by fine or imprisonment, or both, under Section 1001 of Title 18 of the United States Code and that such willful false statements may jeopardize the validity of the application of any patent issued thereon.

Date: 6/12/09

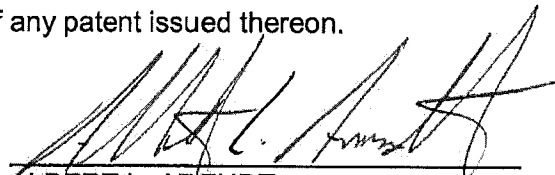
ALBERT L. ARENDT

Electronic Acknowledgement Receipt

EFS ID:	13048194
Application Number:	13103310
International Application Number:	
Confirmation Number:	9050
Title of Invention:	BLOW-MOLDED WHEELS HAVING UNDERCUT TREADS, METHODS FOR PRODUCING THE SAME, AND CHILDREN'S RIDE-ON VEHICLES INCLUDING THE SAME
First Named Inventor/Applicant Name:	Albert L. Arendt
Correspondence Address:	David S. D'Ascenzo DASCENZO INTELLECTUAL PROPERTY LAW, P.C. Suite 925 522 S.W. 5th Avenue Portland OR 97204 US 5032247529 david@dascenzoiplaw.com
Filer:	David S. D'Ascenzo/Robin Davin
Filer Authorized By:	David S. D'Ascenzo
Attorney Docket Number:	MPW 3M1B
Receipt Date:	19-JUN-2012
Filing Date:	09-MAY-2011
Time Stamp:	12:17:39
Application Type:	Utility under 35 USC 111(a)

Payment information:

Submitted with Payment	no
------------------------	----

File Listing:

Document Number	Document Description	File Name	File Size(Bytes)/ Message Digest	Multi Part /.zip	Pages (if appl.)
1		Response_to_Office_Action_M PW3M1B_6-19-12.pdf	148995 ffff816704f2958e0771a913019b0993930ba t77	yes	12
Multipart Description/PDF files in .zip description					
Document Description			Start	End	
Amendment/Req. Reconsideration-After Non-Final Reject			1	1	
Claims			2	7	
Applicant Arguments/Remarks Made in an Amendment			8	12	
Warnings:					
Information:					
2	Rule 130, 131 or 132 Affidavits	Declaration_of_Albert_L_Aren dt_MPW3M1B.pdf	574565 2dff654e37b0d0338fcc8b25f4b66dc271f30 c3b	no	6
Warnings:					
Information:					
Total Files Size (in bytes):			723560		
<p>This Acknowledgement Receipt evidences receipt on the noted date by the USPTO of the indicated documents, characterized by the applicant, and including page counts, where applicable. It serves as evidence of receipt similar to a Post Card, as described in MPEP 503.</p> <p><u>New Applications Under 35 U.S.C. 111</u> If a new application is being filed and the application includes the necessary components for a filing date (see 37 CFR 1.53(b)-(d) and MPEP 506), a Filing Receipt (37 CFR 1.54) will be issued in due course and the date shown on this Acknowledgement Receipt will establish the filing date of the application.</p> <p><u>National Stage of an International Application under 35 U.S.C. 371</u> If a timely submission to enter the national stage of an international application is compliant with the conditions of 35 U.S.C. 371 and other applicable requirements a Form PCT/DO/EO/903 indicating acceptance of the application as a national stage submission under 35 U.S.C. 371 will be issued in addition to the Filing Receipt, in due course.</p> <p><u>New International Application Filed with the USPTO as a Receiving Office</u> If a new international application is being filed and the international application includes the necessary components for an international filing date (see PCT Article 11 and MPEP 1810), a Notification of the International Application Number and of the International Filing Date (Form PCT/RO/105) will be issued in due course, subject to prescriptions concerning national security, and the date shown on this Acknowledgement Receipt will establish the international filing date of the application.</p>					

Under the Paperwork Reduction Act of 1995, no persons are required to respond to a collection of information unless it displays a valid OMB control number.

PATENT APPLICATION FEE DETERMINATION RECORD Substitute for Form PTO-875	Application or Docket Number 13/103,310	Filing Date 05/09/2011	<input type="checkbox"/> To be Mailed
---	---	----------------------------------	---------------------------------------

APPLICATION AS FILED – PART I			OTHER THAN SMALL ENTITY				
	(Column 1)	(Column 2)	SMALL ENTITY <input type="checkbox"/>	OR			
FOR	NUMBER FILED	NUMBER EXTRA	RATE (\$)	FEE (\$)	OR	RATE (\$)	FEE (\$)
<input type="checkbox"/> BASIC FEE <small>(37 CFR 1.16(a), (b), or (c))</small>	N/A	N/A	N/A			N/A	
<input type="checkbox"/> SEARCH FEE <small>(37 CFR 1.16(k), (j), or (m))</small>	N/A	N/A	N/A			N/A	
<input type="checkbox"/> EXAMINATION FEE <small>(37 CFR 1.16(o), (p), or (q))</small>	N/A	N/A	N/A			N/A	
TOTAL CLAIMS <small>(37 CFR 1.16(j))</small>	minus 20 =	*	X \$ =		OR	X \$ =	
INDEPENDENT CLAIMS <small>(37 CFR 1.16(h))</small>	minus 3 =	*	X \$ =			X \$ =	
<input type="checkbox"/> APPLICATION SIZE FEE <small>(37 CFR 1.16(s))</small>	If the specification and drawings exceed 100 sheets of paper, the application size fee due is \$250 (\$125 for small entity) for each additional 50 sheets or fraction thereof. See 35 U.S.C. 41(a)(1)(G) and 37 CFR 1.16(s).						
<input type="checkbox"/> MULTIPLE DEPENDENT CLAIM PRESENT <small>(37 CFR 1.16(j))</small>							
			TOTAL			TOTAL	

* If the difference in column 1 is less than zero, enter "0" in column 2.

APPLICATION AS AMENDED – PART II					OTHER THAN SMALL ENTITY				
	(Column 1)	(Column 2)	(Column 3)		SMALL ENTITY	OR			
AMENDMENT	06/19/2012	CLAIMS REMAINING AFTER AMENDMENT	HIGHEST NUMBER PREVIOUSLY PAID FOR	PRESENT EXTRA	RATE (\$)	ADDITIONAL FEE (\$)	OR	RATE (\$)	ADDITIONAL FEE (\$)
	Total <small>(37 CFR 1.16(i))</small>	* 20	Minus ** 20	= 0	X \$ =		OR	X \$60=	0
	Independent <small>(37 CFR 1.16(h))</small>	* 2	Minus ***3	= 0	X \$ =		OR	X \$250=	0
	<input type="checkbox"/> Application Size Fee <small>(37 CFR 1.16(s))</small>								
	<input type="checkbox"/> FIRST PRESENTATION OF MULTIPLE DEPENDENT CLAIM <small>(37 CFR 1.16(j))</small>						OR		
					TOTAL ADD'L FEE		OR	TOTAL ADD'L FEE	0

	(Column 1)	(Column 2)	(Column 3)						
AMENDMENT		CLAIMS REMAINING AFTER AMENDMENT	HIGHEST NUMBER PREVIOUSLY PAID FOR	PRESENT EXTRA	RATE (\$)	ADDITIONAL FEE (\$)	OR	RATE (\$)	ADDITIONAL FEE (\$)
	Total <small>(37 CFR 1.16(i))</small>	*	Minus **	=	X \$ =		OR	X \$ =	
	Independent <small>(37 CFR 1.16(h))</small>	*	Minus ***	=	X \$ =		OR	X \$ =	
	<input type="checkbox"/> Application Size Fee <small>(37 CFR 1.16(s))</small>								
	<input type="checkbox"/> FIRST PRESENTATION OF MULTIPLE DEPENDENT CLAIM <small>(37 CFR 1.16(j))</small>						OR		
					TOTAL ADD'L FEE		OR	TOTAL ADD'L FEE	

* If the entry in column 1 is less than the entry in column 2, write "0" in column 3.
 ** If the "Highest Number Previously Paid For" IN THIS SPACE is less than 20, enter "20".
 *** If the "Highest Number Previously Paid For" IN THIS SPACE is less than 3, enter "3".
 The "Highest Number Previously Paid For" (Total or Independent) is the highest number found in the appropriate box in column 1.

Legal Instrument Examiner:
 /RUBY JOHNSON/

This collection of information is required by 37 CFR 1.16. The information is required to obtain or retain a benefit by the public which is to file (and by the USPTO to process) an application. Confidentiality is governed by 35 U.S.C. 122 and 37 CFR 1.14. This collection is estimated to take 12 minutes to complete, including gathering, preparing, and submitting the completed application form to the USPTO. Time will vary depending upon the individual case. Any comments on the amount of time you require to complete this form and/or suggestions for reducing this burden, should be sent to the Chief Information Officer, U.S. Patent and Trademark Office, U.S. Department of Commerce, P.O. Box 1450, Alexandria, VA 22313-1450. DO NOT SEND FEES OR COMPLETED FORMS TO THIS ADDRESS. **SEND TO: Commissioner for Patents, P.O. Box 1450, Alexandria, VA 22313-1450.**

If you need assistance in completing the form, call 1-800-PTO-9199 and select option 2.



UNITED STATES PATENT AND TRADEMARK OFFICE

UNITED STATES DEPARTMENT OF COMMERCE
United States Patent and Trademark Office
Address: COMMISSIONER FOR PATENTS
P.O. Box 1450
Alexandria, Virginia 22313-1450
www.uspto.gov

APPLICATION NO.	FILING DATE	FIRST NAMED INVENTOR	ATTORNEY DOCKET NO.	CONFIRMATION NO.
13/103,310	05/09/2011	Albert L. Arendt	MPW 3MIB	9050
	7590	09/05/2012	EXAMINER	
David S. D'Ascenzo DASCENZO INTELLECTUAL PROPERTY LAW, P.C. Suite 925 522 S.W. 5th Avenue Portland, OR 97204			STABLEY, MICHAEL R	
			ART UNIT	PAPER NUMBER
			3611	
			MAIL DATE	DELIVERY MODE
			09/05/2012	PAPER

Please find below and/or attached an Office communication concerning this application or proceeding.

The time period for reply, if any, is set in the attached communication.

DETAILED ACTION

Claim Rejections - 35 USC § 103

1. The following is a quotation of 35 U.S.C. 103(a) which forms the basis for all obviousness rejections set forth in this Office action:

(a) A patent may not be obtained though the invention is not identically disclosed or described as set forth in section 102 of this title, if the differences between the subject matter sought to be patented and the prior art are such that the subject matter as a whole would have been obvious at the time the invention was made to a person having ordinary skill in the art to which said subject matter pertains. Patentability shall not be negated by the manner in which the invention was made.

2. Claims 1-8, 18, and 19 rejected under 35 U.S.C. 103(a) as being unpatentable over Damon (US 2005/0056474) in view of Gallizia (U.S. 4,088,523).

In re claim 1, Damon discloses a children's ride-on vehicle (10), comprising: a vehicle body (12) having at least one seat sized for a child; a plurality of wheels rotatably coupled to the vehicle body, wherein the plurality of wheels includes at least one driven wheel (36, 38) and at least one steerable wheel (32, 34), wherein at least one of the plurality of wheels is a blow-molded wheel that comprises a blow-molded wheel body having a diameter, an outer surface, first and second sidewalls, a central circumference, and an axis, wherein the blow-molded wheel body is configured to rotate about the axis, wherein the outer surface and the central circumference extend circumferentially around the blow-molded wheel body and between the first and second sidewalls, and wherein the central circumference is equidistant from the first and second sidewalls; a first region of the outer surface, wherein the first region is disposed between the first sidewall and the central circumference of the blow-molded wheel body; a second region of the outer surface, wherein the second region is disposed between the second sidewall and the central circumference of the blow-molded wheel body; but

Art Unit: 3611

does not disclose a recessed region between the first region and the second region, wherein the first region and the second region are directly adjacent to the recessed region, and wherein a first radial distance from the axis to the first region and a second radial distance from the axis to the second region both exceed a third radial distance from the axis to the recessed region by at least the larger of 1/8 inch and 0.1% of the diameter. Gallizia, however, does disclose a first region (1) of the outer surface, wherein the first region is disposed between the first sidewall (8') and the central circumference of the blow-molded wheel body; a second region (left equivalent of 1) of the outer surface, wherein the second region is disposed between the second sidewall (8) and the central circumference of the molded wheel body; and a recessed region (center of tread) between the first region and the second region, wherein the first region and the second region are directly adjacent to the recessed region, and wherein a first radial distance from the axis to the first region and a second radial distance from the axis to the second region both exceed a third radial distance from the axis to the recessed region by at least the larger of 1/8 inch and 0.1% of the diameter as shown in Figure 1. It would have been obvious to one having ordinary skill in the art at the time the invention was made to modify the wheel of Damon such that it comprised the tread pattern of Gallizia to support the vehicle and provide improved traction.

In re claim 2, Gallizia further discloses wherein the recessed region coincides with the central circumference as shown in Figure 1.

In re claim 3, Gallizia further discloses wherein the recessed region overlaps the central circumference as shown in Figure 1.

In re claim 4, Gallizia further discloses wherein the blow-molded wheel body has a part line, and wherein the recessed region coincides with the part line as shown in Figure 1.

In re claim 5, Gallizia further discloses wherein the blow-molded wheel body has a part line, wherein the central circumference coincides with the part line, and wherein the recessed region overlaps the central circumference as shown in Figure 1.

In re claim 6, Gallizia further discloses wherein the first region and the second region of the outer surface are smooth around an entire circumference of the blow-molded wheel body as shown in Figure 1.

In re claim 7, Gallizia further discloses wherein the first radial distance and the second radial distance are generally constant around an entire circumference of the blow-molded wheel body as shown in Figure 1.

In re claim 8, Gallizia further discloses wherein the first region and the second region of the outer surface are substantially smooth around an entire circumference of the blow-molded wheel body as shown in Figure 1.

In re claim 18, Gallizia further discloses wherein the recessed region defines a channel having a generally rectangular cross-section and extending around an entire circumference of the blow-molded wheel body as shown in Figures 1 and 3.

In re claim 19, Gallizia further discloses wherein the channel extends around the central circumference of the blow-molded wheel body as shown in Figure 1.

Art Unit: 3611

Allowable Subject Matter

3. Claims 9-17 objected to as being dependent upon a rejected base claim, but would be allowable if rewritten in independent form including all of the limitations of the base claim and any intervening claims.

The following is a statement of reasons for the indication of allowable subject matter: The specific limitations of “further comprises a third region of the outer surface, wherein the third region is disposed between the first sidewall and the first region; and a fourth region of the outer surface, wherein the fourth region is disposed between the second sidewall and the second region; wherein the third region and the fourth region include a plurality of tread blocks on the outer surface, wherein the plurality of tread blocks are separated and spaced apart from each other on the outer surface” is not anticipated or made obvious by the prior art of record in the examiner’s opinion.

4. Claim 20 allowed.

The following is a statement of reasons for the indication of allowable subject matter: The specific limitations of “a third region of the outer surface, wherein the third region is disposed between the first sidewall and the first region, and wherein the third region includes a plurality of spaced-apart tread blocks on the outer surface; and a fourth region of the outer surface, wherein the fourth region is disposed between the second sidewall and the second region, and wherein fourth region includes a plurality of spaced-apart tread blocks on the outer surface” is not anticipated or made obvious by the prior art of record in the examiner’s opinion.

Response to Arguments

5. Applicant's arguments filed 6/19/12 have been fully considered but they are not persuasive. Applicant argues that Gallizia is formed by an injection molding process, not a blow molding process, and that the technology did not exist to enable a blow molded wheel to have the specified undercuts. The Examiner, however, notes that in an apparatus claim, it does not matter what process was used to make such a wheel as long as the same product is produced. Therefore, since blow molding and injection molding are interchangeable molding methods when it comes to the end product, either could be used to produce the wheel as discussed above.

6. The declaration under 37 CFR 1.132 filed 8/23/06 is insufficient to overcome the rejection of claims 1-8, 18, and 19 based upon Damon and Gallizia under 35 U.S.C. 103 because in an apparatus claim, it does not matter what process was used to make such a wheel as long as the same product is produced.

Conclusion

7. **THIS ACTION IS MADE FINAL.** Applicant is reminded of the extension of time policy as set forth in 37 CFR 1.136(a).

A shortened statutory period for reply to this final action is set to expire THREE MONTHS from the mailing date of this action. In the event a first reply is filed within TWO MONTHS of the mailing date of this final action and the advisory action is not mailed until after the end of the THREE-MONTH shortened statutory period, then the shortened statutory period will expire on the date the advisory action is mailed, and any extension fee pursuant to 37 CFR 1.136(a) will be calculated from the mailing date of

Art Unit: 3611

the advisory action. In no event, however, will the statutory period for reply expire later than SIX MONTHS from the mailing date of this final action.

Any inquiry concerning this communication or earlier communications from the examiner should be directed to MICHAEL STABLEY whose telephone number is (571)270-3249. The examiner can normally be reached on M-F 9-5:30.

If attempts to reach the examiner by telephone are unsuccessful, the examiner's supervisor, Lesley D. Morris can be reached on 571-272-6651. The fax phone number for the organization where this application or proceeding is assigned is 571-273-8300.

Information regarding the status of an application may be obtained from the Patent Application Information Retrieval (PAIR) system. Status information for published applications may be obtained from either Private PAIR or Public PAIR. Status information for unpublished applications is available through Private PAIR only. For more information about the PAIR system, see <http://pair-direct.uspto.gov>. Should you have questions on access to the Private PAIR system, contact the Electronic Business Center (EBC) at 866-217-9197 (toll-free). If you would like assistance from a USPTO Customer Service Representative or access to the automated information system, call 800-786-9199 (IN USA OR CANADA) or 571-272-1000.

/Michael R Stabley/
Examiner, Art Unit 3611

/LESLEY D. MORRIS/
Supervisory Patent Examiner, Art Unit 3611

Search Notes 	Application/Control No. 13103310	Applicant(s)/Patent Under Reexamination ARENDR ET AL.
	Examiner MICHAEL STABLEY	Art Unit 3611

SEARCHED			
Class	Subclass	Date	Examiner
280	29	8/29/2012	MS
264	454, 501, 512, 523, 524	8/29/2012	MS
152	209.1	8/29/2012	MS

SEARCH NOTES		
Search Notes	Date	Examiner
EAST Search Results - See Attached	8/29/2012	MS
Consult Primary Kevin Hurley	8/29/2012	MS

INTERFERENCE SEARCH			
Class	Subclass	Date	Examiner

/MICHAEL STABLEY/ Examiner.Art Unit 3611	
---	--

EAST Search History

EAST Search History (Prior Art)

Ref #	Hits	Search Query	DBs	Default Operator	Plurals	Time Stamp
L1	1459	280/29.ccls. or 264/454.ccls. or 152/209.1.ccls.	US-PGPUB; USPAT; USOCR	OR	ON	2012/08/29 20:30
L2	788	152/209.1.ccls.	US-PGPUB; USPAT; USOCR	OR	ON	2012/08/29 20:30
L3	1736	264/501.ccls. or 264/512.ccls. or 264/523.ccls. or 264/524.ccls.	US-PGPUB; USPAT; USOCR	OR	ON	2012/08/29 20:30
S1	67	("2601700" "20030085611" "20040070262" "20050056474" "3029468" "3264780" "3373460" "3592885" "3616491" "3692453" "3730658" "3779688" "3817676" "3851029" "3888545" "3907370" "3936264" "3135997" "3570057" "4063868" "4323411" "4513981" "4531704" "4588842" "4717113" "4832307" "4854849" "4884961" "4889480" "4516648" "5104198" "5219594" "5227114" "5316135" "5316377" "5368371" "5518682" "5556601" "5573129" "5736168" "5750067" "5799809" "5810452" "5908124" "5924506" "6068161" "6095543" "6170920" "6318983" "6431406" "6464305" "6520597" "6591986" "6872354" "6896335" "6913324" "6953333" "6470982").PN.	US-PGPUB; USPAT; USOCR	OR	ON	2009/01/28 11:16
S3	14	("3730594" "3894776" "4358162" "5104198" "5368371").PN. OR ("6170920").URPN.	US-PGPUB; USPAT; USOCR	OR	ON	2009/01/28 15:14
S4	325	(tire or wheel) near5 (blow adj mold\$3)	US-PGPUB; USPAT; USOCR	OR	ON	2009/01/28 15:23
S5	14	("3870372" "3960474" "4040670" "4088523" "4301850" "4722131" "5104198" "5114522" "5133591").PN. OR ("5518682").URPN.	US-PGPUB; USPAT; USOCR	OR	ON	2009/01/28 16:19
S6	18	("1560551" "1687113" "2969254" "3387894" "3870372" "4592595" "5104198" "5129709").PN. OR ("5316377").URPN.	US-PGPUB; USPAT; USOCR	OR	ON	2009/01/28 16:27
S7	14	("3870372" "3960474" "4040670" "4088523" "4301850" "4722131"	US-PGPUB;	OR	ON	2009/03/20 14:14

		"5104198" "5114522" "5133591").PN. OR ("5518682").URPN.	USPAT; USOCR			
S8	18	("1560551" "1687113" "2969254" "3387894" "3870372" "4592595" "5104198" "5129709").PN. OR ("5316377").URPN.	US-PGPUB; USPAT; USOCR	OR	ON	2009/03/20 14:15
S9	1277	280/29.ccls. or 264/454.ccls. or 152/209.1.ccls.	US-PGPUB; USPAT; USOCR	OR	ON	2009/08/03 15:49
S10	674	152/209.1.ccls.	US-PGPUB; USPAT; USOCR	OR	ON	2009/08/03 15:50
S12	72	("2601700" "20030085611" "20040070262" "20050056474" "20080006456" "3029468" "3135997" "3264780" "3373460" "3570057" "3592885" "3616491" "3692453" "3730658" "3779688" "3817676" "3851029" "3888545" "3907370" "3936264" "4063868" "4323411" "4513981" "4516648" "4531704" "4588542" "4717113" "4832307" "4854849" "4884961" "4889480" "5104198" "5219594" "5227114" "5316135" "5316377" "5368371" "5518682" "5556601" "5573129" "5736168" "5750067" "5799809" "5810452" "5879484" "5908124" "5924506" "6068161" "6095543" "6170920" "6318983" "6431406" "6446981" "6464305" "6470982" "6520597" "6591986" "6872354" "6896335" "6913324" "6953333" "7621543" "D327048").PN.	US-PGPUB; USPAT; USOCR	OR	ON	2011/10/23 12:17
S13	1411	280/29.ccls. or 264/454.ccls. or 152/209.1.ccls.	US-PGPUB; USPAT; USOCR	OR	ON	2011/10/23 12:17
S14	1650	264/501.ccls. or 264/512.ccls. or 264/523.ccls. or 264/524.ccls.	US-PGPUB; USPAT; USOCR	OR	ON	2011/10/23 12:19
S15	1650	264/501.ccls. or 264/512.ccls. or 264/523.ccls. or 264/524.ccls.	US-PGPUB; USPAT; USOCR	OR	ON	2011/10/24 10:00
S16	680	S15 and (blow adj mold\$3)	US-PGPUB; USPAT; USOCR	OR	ON	2011/10/24 10:00
S17	39	S15 and ((blow adj mold\$3) same (tire or wheel))	US-PGPUB; USPAT; USOCR	OR	ON	2011/10/24 10:01
S18	35	("1560551" "1687113" "2969254" "3387894" "3870372" "3960474" "4040670" "4088523" "4301850" "4592595" "4722131" "5104198"	US-PGPUB; USPAT; USOCR	OR	ON	2011/10/24 17:08

		"5114522" "5129709" "5133591").PN. OR ("5316377" "5518682").URPN.				
S19	11	(US-20050056474-\$).did. or (US-6464305-\$ or US-6170920-\$ or US-5924506-\$ or US-5368371-\$ or US-6446981-\$ or US-5518682-\$ or US-5316377-\$ or US-D327048-\$ or US-5104198-\$ or US-4088523-\$).did.	US-PGPUB; USPAT	OR	ON	2011/10/24 20:02
S20	72	("2601700" "20030085611" "20040070262" "20050056474" "20080006456" "3029468" "3135997" "3264780" "3373460" "3570057" "3592885" "3616491" "3692453" "3730658" "3779688" "3817676" "3851029" "3888545" "3907370" "3936264" "4063868" "4323411" "4513981" "4516648" "4531704" "4588542" "4717113" "4832307" "4854849" "4884961" "4889480" "5104198" "5219594" "5227114" "5316135" "5316377" "5368371" "5518682" "5556601" "5573129" "5736168" "5750067" "5799809" "5810452" "5879484" "5908124" "5924506" "6068161" "6095543" "6170920" "6318983" "6431406" "6446981" "6464305" "6470982" "6520597" "6591986" "6872354" "6896335" "6913324" "6953333" "7621543" "D327048").PN.	US-PGPUB; USPAT; USOCR	OR	ON	2011/10/24 20:03
S21	1	S19 not S20	US-PGPUB; USPAT; USOCR	OR	ON	2011/10/24 20:03
S22	8	(tire or wheel) same (blow adj mold\$3) and (tread adj blocks)	US-PGPUB; USPAT; USOCR	OR	ON	2011/10/25 10:45
S23	72	("20030085611" "20040070262" "20050056474" "20080006456" "2601700" "3029468" "3135997" "3264780" "3373460" "3570057" "3592885" "3616491" "3692453" "3730658" "3779688" "3817676" "3851029" "3888545" "3907370" "3936264" "4063868" "4323411" "4513981" "4516648" "4531704" "4588542" "4717113" "4832307" "4854849" "4884961" "4889480" "5104198" "5219594" "5227114" "5316135" "5316377" "5368371" "5518682" "5556601" "5573129" "5736168" "5750067" "5799809" "5810452" "5879484" "5908124" "5924506" "6068161" "6095543" "6170920" "6318983" "6431406" "6446981" "6464305" "6470982" "6520597" "6591986" "6872354" "6896335" "6913324" "6953333" "7621543" "D327048").PN. OR ("7939008").URPN.	US-PGPUB; USPAT; USOCR	OR	ON	2011/10/25 10:57
S24	1687	264/501.ccls. or 264/512.ccls. or 264/523.ccls. or 264/524.ccls.	US-PGPUB; USPAT;	OR	ON	2012/04/10 10:04

			USOCR			
S25	1435	280/29.ccls. or 264/454.ccls. or 152/209.1.ccls.	US-PGPUB; USPAT; USOCR	OR	ON	2012/04/10 10:04
S26	772	152/209.1.ccls.	US-PGPUB; USPAT; USOCR	OR	ON	2012/04/10 10:04
S27	429	(tire or wheel) near5 (blow adj mold\$3)	US-PGPUB; USPAT; USOCR	OR	ON	2012/04/10 10:50
S28	80	S27 and child\$3	US-PGPUB; USPAT; USOCR	OR	ON	2012/04/10 10:50
S29	58	(tire or wheel) near5 (blow adj mould\$3)	US-PGPUB; USPAT; USOCR	OR	ON	2012/04/10 11:00
S30	2	S29 and child\$3	US-PGPUB; USPAT; USOCR	OR	ON	2012/04/10 11:00
S31	344	(tire or wheel) near3 (blow adj mold\$3)	US-PGPUB; USPAT; USOCR	OR	ON	2012/04/10 11:28
S32	288	S31 not S28	US-PGPUB; USPAT; USOCR	OR	ON	2012/04/10 11:29
S33	34	S32 and (vehicle or car or toy)	US-PGPUB; USPAT; USOCR	OR	ON	2012/04/10 11:30
S34	9	("3264780").URPN.	USPAT	OR	OFF	2012/04/10 11:34
S35	79	("1930835" "20030085611" "20040070262" "20050056474" "20060073289" "20060231303" "20080006456" "2601700" "3029468" "3135997" "3264780" "3373460" "3570057" "3592885" "3616491" "3692453" "3730658" "3779688" "3817676" "3851029" "3888545" "3907370" "3936264" "4063868" "4323411" "4513981" "4516648" "4531704" "4588542" "4717113" "4832307" "4854849" "4884961" "4889480" "5104198" "5219594" "5227114" "5316135" "5316377" "5368371" "5518682" "5553878" "5556601" "5573129" "5736168" "5750067" "5799809" "5810452" "5879484" "5908124" "5924506" "6068161" "6095543" "6170920" "6318983" "6431406" "6446981" "6464305" "6470982" "6520597" "6591986" "6615885"	US-PGPUB; USPAT; USOCR	OR	OFF	2012/04/10 11:35

		"6872354" "6896335" "6913324" "6953333" "7621543" "D327048").PN. OR ("7621543" "7905305" "7939008").URPN.				
S36	72	("20030085611" "20040070262" "20050056474" "20080006456" "2601700" "3029468" "3135997" "3264780" "3373460" "3570057" "3592885" "3616491" "3692453" "3730658" "3779688" "3817676" "3851029" "3888545" "3907370" "3936264" "4063868" "4323411" "4513981" "4516648" "4531704" "4588542" "4717113" "4832307" "4854849" "4884961" "4889480" "5104198" "5219594" "5227114" "5316135" "5316377" "5368371" "5518682" "5556601" "5573129" "5736168" "5750067" "5799809" "5810452" "5879484" "5908124" "5924506" "6068161" "6095543" "6170920" "6318983" "6431406" "6446981" "6464305" "6470982" "6520597" "6591986" "6872354" "6896335" "6913324" "6953333" "7621543" "D327048").PN. OR ("7939008").URPN.	US- PGPUB; USPAT; USOCR	OR	OFF	2012/04/10 11:37

EAST Search History (Interference)

Ref #	Hits	Search Query	DBs	Default Operator	Plurals	Time Stamp
S11	0	(vehicle and body and wheels and molded and tread and surface and region and radial and distance and steering and assembly and drive).clm.	USPAT; UPAD	OR	ON	2009/08/03 16:05

8/ 29/ 2012 8:31:01 PM

C:\Users\mstabley\Documents\EAST\Workspaces\13103310.wsp

IN THE UNITED STATES PATENT AND TRADEMARK OFFICE

October 8, 2012

In re Application of:

ALBERT L. ARENDT, JAMES R. CARDUCCI, and CHRISTOPHER F. LUCAS

Serial No. : 13/103,310 Group Art Unit: 3611
Filed : May 9, 2011 Examiner: Michael R. Stabley
For : BLOW-MOLDED WHEELS HAVING UNDERCUT TREADS,
METHODS FOR PRODUCING THE SAME, AND CHILDREN'S
RIDE-ON VEHICLES INCLUDING THE SAME

Mail Stop AF
Commissioner for Patents
PO Box 1450
Alexandria, Virginia 22313-1450

AMENDMENT AND RESPONSE TO FINAL OFFICE ACTION

In response to the final Office action dated September 5, 2012, please consider the following amendments and remarks.

Claim Amendments	Begin on page 2.
Remarks	Begin on page 9.

CLAIM AMENDMENTS

This listing of claims reflects all claim amendments and replaces all prior versions, and listings, of claims in the application. Material to be inserted in claims is in **bold and underline**, and material to be deleted is in ~~strikeout~~ or (if the deletion is of five or fewer consecutive characters or would be difficult to see) in bold double brackets **[[]]**.

1. (Canceled).

2. (Currently amended) The children's ride-on vehicle of claim **[1] 2**, wherein the recessed region coincides with the central circumference.

3. (Currently amended) The children's ride-on vehicle of claim **[1] 2**, wherein the recessed region overlaps the central circumference.

4. (Currently amended) The children's ride-on vehicle of claim **[1] 2**, wherein the blow-molded wheel body has a part line, and wherein the recessed region coincides with the part line.

5. (Currently amended) The children's ride-on vehicle of claim **[1] 2**, wherein the blow-molded wheel body has a part line, wherein the central circumference coincides with the part line, and wherein the recessed region overlaps the central circumference.

6. (Currently amended) The children's ride-on vehicle of claim [[1]] 9, wherein the first region and the second region of the outer surface are smooth around an entire circumference of the blow-molded wheel body.

7. (Currently amended) The children's ride-on vehicle of claim [[1]] 9, wherein the first radial distance and the second radial distance are generally constant around an entire circumference of the blow-molded wheel body.

8. (Currently amended) The children's ride-on vehicle of claim [[1]] 9, wherein the first region and the second region of the outer surface are substantially smooth around an entire circumference of the blow-molded wheel body.

9. (Currently amended) ~~The children's ride-on vehicle of claim 8, wherein the blow-molded wheel further comprises:~~ **A children's ride-on vehicle, comprising:**

a vehicle body having at least one seat sized for a child; and

a plurality of wheels rotatably coupled to the vehicle body, wherein the plurality of wheels includes at least one driven wheel and at least one steerable wheel, wherein at least one of the plurality of wheels is a blow-molded wheel that comprises:

a blow-molded wheel body having a diameter, an outer surface, first and second sidewalls, a central circumference, and an axis, wherein the blow-molded wheel body is configured to rotate about the axis, wherein the outer surface and the central circumference extend circumferentially around the blow-molded wheel body and between

the first and second sidewalls, and wherein the central circumference is equidistant from the first and second sidewalls;

a first region of the outer surface, wherein the first region is disposed between the first sidewall and the central circumference of the blow-molded wheel body;

a second region of the outer surface, wherein the second region is disposed between the second sidewall and the central circumference of the blow-molded wheel body;

a recessed region between the first region and the second region, wherein the first region and the second region are directly adjacent to the recessed region, and wherein a first radial distance from the axis to the first region and a second radial distance from the axis to the second region both exceed a third radial distance from the axis to the recessed region by at least the larger of 1/8 inch and 0.1% of the diameter;

a third region of the outer surface, wherein the third region is disposed between the first sidewall and the first region; and

a fourth region of the outer surface, wherein the fourth region is disposed between the second sidewall and the second region;

wherein the third region and the fourth region include a plurality of tread blocks on the outer surface, wherein the plurality of tread blocks are separated and spaced apart from each other on the outer surface.

10. (Original) The children's ride-on vehicle of claim 9, wherein at least a subset of the plurality of tread blocks have more than one radial distance from the axis to the respective tread block.

11. (Original) The children's ride-on vehicle of claim 9, wherein at least a portion of the outer surface between the plurality of tread blocks is generally V-shaped.

12. (Original) The children's ride-on vehicle of claim 9, wherein at least a subset of the plurality of tread blocks are generally V-shaped.

13. (Original) The children's ride-on vehicle of claim 9, wherein at least a subset of the plurality of tread blocks are generally U-shaped.

14. (Original) The children's ride-on vehicle of claim 9, wherein at least a subset of the plurality of tread blocks are partially coextensive with the first region and the second region.

15. (Original) The children's ride-on vehicle of claim 9, wherein at least a subset of the plurality of tread blocks extend from an adjacent portion of the outer surface by at least the larger of 1/8 inch and 0.1% of the diameter.

16. (Original) The children's ride-on vehicle of claim 9, wherein at least a subset of the plurality of tread blocks include walls extending from a base surface to define the respective tread blocks, wherein the walls extend at least partially transverse across the outer surface at angles relative to the central circumference.

17. (Original) The children's ride-on vehicle of claim 9, wherein at least a subset of the plurality of tread blocks partially extend onto at least one of the first sidewall and the second sidewall.

18. (Currently amended) The children's ride-on vehicle of claim ~~[[1]]~~ 9, wherein the recessed region defines a channel having a generally rectangular cross-section and extending around an entire circumference of the blow-molded wheel body.

19. (Original) The children's ride-on vehicle of claim 18, wherein the channel extends around the central circumference of the blow-molded wheel body.

20. (Original) A children's ride-on vehicle, comprising:

a vehicle body having at least one seat sized for a child;

a plurality of wheels rotatably coupled to the vehicle body, wherein the plurality of wheels includes at least one driven wheel and at least one steerable wheel, wherein at least one of the plurality of wheels is a blow-molded wheel that comprises:

a blow-molded wheel body having a diameter, an outer surface, first and second sidewalls, a central circumference, and an axis, wherein the blow-molded wheel body is configured to rotate about the axis, wherein the outer surface and the central circumference extend circumferentially around the blow-molded wheel body and between the first and second sidewalls, and wherein the central circumference is equidistant from the first and second sidewalls;

a first region of the outer surface, wherein the first region is disposed between the first sidewall and the central circumference of the blow-molded wheel body, and wherein the first region is smooth with a first radial distance from the axis to the first region that is generally constant around an entire circumference of the blow-molded wheel body;

a second region of the outer surface, wherein the second region is disposed between the second sidewall and the central circumference of the blow-molded wheel body, and wherein the second region is smooth with a second radial distance from the axis to the second region that is generally constant around an entire circumference of the blow-molded wheel body;

a recessed region between the first region and the second region, wherein the first region and the second region are directly adjacent to the recessed region, and wherein the first radial distance and the second radial distance both exceed a third radial distance from the axis to the recessed region by at least the larger of 1/8 inch and 0.1% of the diameter;

a third region of the outer surface, wherein the third region is disposed between the first sidewall and the first region, and wherein the third region includes a plurality of spaced-apart tread blocks on the outer surface; and

a fourth region of the outer surface, wherein the fourth region is disposed between the second sidewall and the second region, and wherein fourth region includes a plurality of spaced-apart tread blocks on the outer surface.

21. (New) The children's ride-on vehicle of claim 20, wherein the vehicle further comprises a steering assembly including a steering mechanism configured to receive steering inputs from a child sitting on the at least one seat and a steering linkage configured to convey the

steering inputs to the at least one steerable wheel, and wherein the vehicle even further comprises a drive assembly configured to selectively drive the rotation of the at least one driven wheel.

22. (New) The children's ride-on vehicle of claim 21, wherein the drive assembly comprises a motor assembly with at least one electric motor configured to drive the rotation of the at least one driven wheel when the motor assembly is energized, and a battery assembly adapted to selectively energize the motor assembly.

23. (New) The children's ride-on vehicle of claim 9, wherein the vehicle further comprises a steering assembly including a steering mechanism configured to receive steering inputs from a child sitting on the at least one seat and a steering linkage configured to convey the steering inputs to the at least one steerable wheel, and wherein the vehicle even further comprises a drive assembly configured to selectively drive the rotation of the at least one driven wheel.

24. (New) The children's ride-on vehicle of claim 23, wherein the drive assembly comprises a motor assembly with at least one electric motor configured to drive the rotation of the at least one driven wheel when the motor assembly is energized, and a battery assembly adapted to selectively energize the motor assembly.

REMARKS

These remarks are responsive to the Office action mailed on September 5, 2012. In the Office action, claims 1–8, 18, and 19 were rejected as being obvious over a proposed combination of U.S. Patent Application Publication No. 2005/0056474 to Damon and U.S. Patent No. 4,088,523 to Gallizia et al., claims 9–17 were indicated to include allowable subject matter, and claim 20 was allowed. Applicants continue to traverse and disagree with the rejections; however, in an effort to efficiently advance prosecution, Applicants presently amend claim 9 into independent form and to incorporate all of the subject matter of independent claim 1. Applicants therefore cancel independent claim 1 without prejudice and amend the dependencies of claims 2–8 and 18 accordingly. Applicants are not abandoning the subject matter of canceled independent claim 1 and understand that pursuit of a patent directed to this subject matter may be pursued in a related patent application at a later date.

In the above amendments, Applicants also add new dependent claims 21-24, which depend from as-amended allowable independent claim 9 and allowed independent claim 20. Claims 21 and 23 recite that the children's ride-on vehicle includes a steering assembly to provide steering inputs to the vehicle's at least one steerable wheel, and a drive assembly to drive the rotation of the vehicle's at least one driven wheel. Claims 22 and 24 recite that the drive assembly includes a motor assembly and a battery assembly. Support for these new dependent claims is found throughout the specification and drawings, including Figs. 1-3, the paragraph beginning on page 11, line 5, and the paragraph beginning on page 11, line 15. Applicants recognize that the addition of these new dependent claims increases the overall number of pending claims by three claims (after cancellation of claim 1 without prejudice). However, as these claims represent subject matter that has already been searched in the parent application

from which this continuation application depends, and because these claims depend from allowable/allowed claims, Applicants submit that entry of these new claims at this time is not unduly burdensome and would not require a new search. However, if the Examiner disagrees and believes that adding these claims would be a reason to deny entry of the other claim amendments requested herein, Applicants proactively authorize the Examiner to cancel without prejudice proposed new claims 22-24 (if adding a single new dependent claim that does not increase the overall number of claims is still permissible), or to cancel without prejudice proposed new claims 21-24.

With entry of the present amendments, Applicants believe that the application is in condition for allowance. Applicants therefore respectfully request that the Examiner issue a Notice of Allowance covering all of the pending claims. If the Examiner has any questions, or any issues remain, please contact the undersigned.

CERTIFICATE OF E-FILING

I hereby certify that this correspondence is being transmitted electronically via the United States Patent and Trademark Office's EFS-Web System on October 8, 2012.



David S. D'Ascenzo

Respectfully submitted,

DASCENZO INTELLECTUAL
PROPERTY LAW, P.C.



David S. D'Ascenzo
Registration No. 39,952
Customer No. 78569
DASCENZO INTELLECTUAL
PROPERTY LAW, P.C.
522 S.W. 5th Ave, Suite 925
Portland, Oregon 97204
Telephone: (503) 224-7529
Facsimile: (503) 224-7329

Electronic Patent Application Fee Transmittal

Application Number:	13103310
Filing Date:	09-May-2011
Title of Invention:	BLOW-MOLDED WHEELS HAVING UNDERCUT TREADS, METHODS FOR PRODUCING THE SAME, AND CHILDREN'S RIDE-ON VEHICLES INCLUDING THE SAME
First Named Inventor/Applicant Name:	Albert L. Arendt
Filer:	David S. D'Ascenzo/Robin Davin
Attorney Docket Number:	MPW 3M1B

Filed as Large Entity

Utility under 35 USC 111(a) Filing Fees

Description	Fee Code	Quantity	Amount	Sub-Total in USD(\$)
Basic Filing:				
Pages:				
Claims:				
Claims in excess of 20	1202	3	62	186

Miscellaneous-Filing:

Petition:

Patent-Appeals-and-Interference:

Post-Allowance-and-Post-Issuance:

Extension-of-Time:

208 of 241

Description	Fee Code	Quantity	Amount	Sub-Total in USD(\$)
Miscellaneous:				
Total in USD (\$)				186

Electronic Acknowledgement Receipt

EFS ID:	13931305
Application Number:	13103310
International Application Number:	
Confirmation Number:	9050
Title of Invention:	BLOW-MOLDED WHEELS HAVING UNDERCUT TREADS, METHODS FOR PRODUCING THE SAME, AND CHILDREN'S RIDE-ON VEHICLES INCLUDING THE SAME
First Named Inventor/Applicant Name:	Albert L. Arendt
Correspondence Address:	David S. D'Ascenzo DASCENZO INTELLECTUAL PROPERTY LAW, P.C. Suite 925 522 S.W. 5th Avenue Portland OR 97204 US 5032247529 david@dascenzoiplaw.com
Filer:	David S. D'Ascenzo/Robin Davin
Filer Authorized By:	David S. D'Ascenzo
Attorney Docket Number:	MPW 3M1B
Receipt Date:	08-OCT-2012
Filing Date:	09-MAY-2011
Time Stamp:	15:44:20
Application Type:	Utility under 35 USC 111(a)

Payment information:

Submitted with Payment	yes
Payment Type	Deposit Account
Payment was successfully received in RAM	\$186

RAM confirmation Number	18917
Deposit Account	504551
Authorized User	

The Director of the USPTO is hereby authorized to charge indicated fees and credit any overpayment as follows:

Charge any Additional Fees required under 37 C.F.R. Section 1.21 (Miscellaneous fees and charges)

File Listing:

Document Number	Document Description	File Name	File Size(Bytes)/ Message Digest	Multi Part /.zip	Pages (if appl.)
1		Amendment_and_Response_to_Final_Office_Action_MPW3 M1B_10-8-12.pdf	180426 <small>fd9d983479c079309251487d170ff6cc31ee17fa</small>	yes	10

Multipart Description/PDF files in .zip description

Document Description	Start	End
Amendment After Final	1	1
Claims	2	8
Applicant Arguments/Remarks Made in an Amendment	9	10

Warnings:

Information:

2	Fee Worksheet (SB06)	fee-info.pdf	30616 <small>18958f9dd0ee968ba8d022a95c6c5a8bfc682a05</small>	no	2
---	----------------------	--------------	--	----	---

Warnings:

Information:

Total Files Size (in bytes): 211042

This Acknowledgement Receipt evidences receipt on the noted date by the USPTO of the indicated documents, characterized by the applicant, and including page counts, where applicable. It serves as evidence of receipt similar to a Post Card, as described in MPEP 503.

New Applications Under 35 U.S.C. 111

If a new application is being filed and the application includes the necessary components for a filing date (see 37 CFR 1.53(b)-(d) and MPEP 506), a Filing Receipt (37 CFR 1.54) will be issued in due course and the date shown on this Acknowledgement Receipt will establish the filing date of the application.

National Stage of an International Application under 35 U.S.C. 371

If a timely submission to enter the national stage of an international application is compliant with the conditions of 35 U.S.C. 371 and other applicable requirements a Form PCT/DO/EO/903 indicating acceptance of the application as a national stage submission under 35 U.S.C. 371 will be issued in addition to the Filing Receipt, in due course.

New International Application Filed with the USPTO as a Receiving Office

If a new international application is being filed and the international application includes the necessary components for an international filing date (see PCT Article 11 and MPEP 1810), a Notification of the International Application Number and of the International Filing Date (Form PCT/RO/105) will be issued in due course, subject to prescriptions concerning national security, and the date shown on this Acknowledgement Receipt will establish the international filing date of the application.

Under the Paperwork Reduction Act of 1995, no persons are required to respond to a collection of information unless it displays a valid OMB control number.

PATENT APPLICATION FEE DETERMINATION RECORD Substitute for Form PTO-875	Application or Docket Number 13/103,310	Filing Date 05/09/2011	<input type="checkbox"/> To be Mailed
---	---	----------------------------------	---------------------------------------

APPLICATION AS FILED – PART I			OTHER THAN SMALL ENTITY			
	(Column 1)	(Column 2)	SMALL ENTITY <input type="checkbox"/>	OR	SMALL ENTITY	
FOR	NUMBER FILED	NUMBER EXTRA	RATE (\$)		FEE (\$)	
<input type="checkbox"/> BASIC FEE <small>(37 CFR 1.16(a), (b), or (c))</small>	N/A	N/A	N/A			N/A
<input type="checkbox"/> SEARCH FEE <small>(37 CFR 1.16(k), (j), or (m))</small>	N/A	N/A	N/A			N/A
<input type="checkbox"/> EXAMINATION FEE <small>(37 CFR 1.16(o), (p), or (q))</small>	N/A	N/A	N/A			N/A
TOTAL CLAIMS <small>(37 CFR 1.16(j))</small>	minus 20 =	*	X \$ =	OR		X \$ =
INDEPENDENT CLAIMS <small>(37 CFR 1.16(h))</small>	minus 3 =	*	X \$ =			X \$ =
<input type="checkbox"/> APPLICATION SIZE FEE <small>(37 CFR 1.16(s))</small>	If the specification and drawings exceed 100 sheets of paper, the application size fee due is \$250 (\$125 for small entity) for each additional 50 sheets or fraction thereof. See 35 U.S.C. 41(a)(1)(G) and 37 CFR 1.16(s).					
<input type="checkbox"/> MULTIPLE DEPENDENT CLAIM PRESENT <small>(37 CFR 1.16(j))</small>						
			TOTAL		TOTAL	

* If the difference in column 1 is less than zero, enter "0" in column 2.

APPLICATION AS AMENDED – PART II					OTHER THAN SMALL ENTITY			
	(Column 1)	(Column 2)	(Column 3)		SMALL ENTITY	OR	SMALL ENTITY	
AMENDMENT	10/08/2012	CLAIMS REMAINING AFTER AMENDMENT	HIGHEST NUMBER PREVIOUSLY PAID FOR	PRESENT EXTRA	RATE (\$)		ADDITIONAL FEE (\$)	
	Total <small>(37 CFR 1.16(i))</small>	* 23	Minus ** 20	= 3	X \$ =	OR	X \$62=	186
	Independent <small>(37 CFR 1.16(h))</small>	* 2	Minus ***3	= 0	X \$ =	OR	X \$250=	0
<input type="checkbox"/> Application Size Fee <small>(37 CFR 1.16(s))</small>								
<input type="checkbox"/> FIRST PRESENTATION OF MULTIPLE DEPENDENT CLAIM <small>(37 CFR 1.16(j))</small>								
					TOTAL ADD'L FEE		TOTAL ADD'L FEE	186

	(Column 1)	(Column 2)	(Column 3)		SMALL ENTITY	OR	SMALL ENTITY	
AMENDMENT		CLAIMS REMAINING AFTER AMENDMENT	HIGHEST NUMBER PREVIOUSLY PAID FOR	PRESENT EXTRA	RATE (\$)		ADDITIONAL FEE (\$)	
	Total <small>(37 CFR 1.16(i))</small>	*	Minus **	=	X \$ =	OR	X \$ =	
	Independent <small>(37 CFR 1.16(h))</small>	*	Minus ***	=	X \$ =	OR	X \$ =	
<input type="checkbox"/> Application Size Fee <small>(37 CFR 1.16(s))</small>								
<input type="checkbox"/> FIRST PRESENTATION OF MULTIPLE DEPENDENT CLAIM <small>(37 CFR 1.16(j))</small>								
					TOTAL ADD'L FEE		TOTAL ADD'L FEE	

* If the entry in column 1 is less than the entry in column 2, write "0" in column 3.
 ** If the "Highest Number Previously Paid For" IN THIS SPACE is less than 20, enter "20".
 *** If the "Highest Number Previously Paid For" IN THIS SPACE is less than 3, enter "3".

The "Highest Number Previously Paid For" (Total or Independent) is the highest number found in the appropriate box in column 1.

Legal Instrument Examiner:
/DANTE SMITH/

This collection of information is required by 37 CFR 1.16. The information is required to obtain or retain a benefit by the public which is to file (and by the USPTO to process) an application. Confidentiality is governed by 35 U.S.C. 122 and 37 CFR 1.14. This collection is estimated to take 12 minutes to complete, including gathering, preparing, and submitting the completed application form to the USPTO. Time will vary depending upon the individual case. Any comments on the amount of time you require to complete this form and/or suggestions for reducing this burden, should be sent to the Chief Information Officer, U.S. Patent and Trademark Office, U.S. Department of Commerce, P.O. Box 1450, Alexandria, VA 22313-1450. DO NOT SEND FEES OR COMPLETED FORMS TO THIS ADDRESS. **SEND TO: Commissioner for Patents, P.O. Box 1450, Alexandria, VA 22313-1450.**

If you need assistance in completing the form, call 1-800-PTO-9199 and select option 2.



NOTICE OF ALLOWANCE AND FEE(S) DUE

7590 11/06/2012
David S. D'Ascenzo
DASCENZO INTELLECTUAL PROPERTY LAW, P.C.
Suite 925
522 S.W. 5th Avenue
Portland, OR 97204

EXAMINER

STABLEY, MICHAEL R

ART UNIT PAPER NUMBER

3611

DATE MAILED: 11/06/2012

Table with 5 columns: APPLICATION NO., FILING DATE, FIRST NAMED INVENTOR, ATTORNEY DOCKET NO., CONFIRMATION NO.

13/103,310 05/09/2011 Albert L. Arendt MPW 3M1B 9050

TITLE OF INVENTION: BLOW-MOLDED WHEELS HAVING UNDERCUT TREADS, METHODS FOR PRODUCING THE SAME, AND CHILDREN'S RIDE-ON VEHICLES INCLUDING THE SAME

Table with 7 columns: APPLN. TYPE, SMALL ENTITY, ISSUE FEE DUE, PUBLICATION FEE DUE, PREV. PAID ISSUE FEE, TOTAL FEE(S) DUE, DATE DUE

nonprovisional NO \$1770 \$300 \$0 \$2070 02/06/2013

THE APPLICATION IDENTIFIED ABOVE HAS BEEN EXAMINED AND IS ALLOWED FOR ISSUANCE AS A PATENT. PROSECUTION ON THE MERITS IS CLOSED. THIS NOTICE OF ALLOWANCE IS NOT A GRANT OF PATENT RIGHTS. THIS APPLICATION IS SUBJECT TO WITHDRAWAL FROM ISSUE AT THE INITIATIVE OF THE OFFICE OR UPON PETITION BY THE APPLICANT. SEE 37 CFR 1.313 AND MPEP 1308.

THE ISSUE FEE AND PUBLICATION FEE (IF REQUIRED) MUST BE PAID WITHIN THREE MONTHS FROM THE MAILING DATE OF THIS NOTICE OR THIS APPLICATION SHALL BE REGARDED AS ABANDONED. THIS STATUTORY PERIOD CANNOT BE EXTENDED. SEE 35 U.S.C. 151. THE ISSUE FEE DUE INDICATED ABOVE DOES NOT REFLECT A CREDIT FOR ANY PREVIOUSLY PAID ISSUE FEE IN THIS APPLICATION. IF AN ISSUE FEE HAS PREVIOUSLY BEEN PAID IN THIS APPLICATION (AS SHOWN ABOVE), THE RETURN OF PART B OF THIS FORM WILL BE CONSIDERED A REQUEST TO REAPPLY THE PREVIOUSLY PAID ISSUE FEE TOWARD THE ISSUE FEE NOW DUE.

HOW TO REPLY TO THIS NOTICE:

I. Review the SMALL ENTITY status shown above.

If the SMALL ENTITY is shown as YES, verify your current SMALL ENTITY status:

A. If the status is the same, pay the TOTAL FEE(S) DUE shown above.

B. If the status above is to be removed, check box 5b on Part B - Fee(s) Transmittal and pay the PUBLICATION FEE (if required) and twice the amount of the ISSUE FEE shown above, or

If the SMALL ENTITY is shown as NO:

A. Pay TOTAL FEE(S) DUE shown above, or

B. If applicant claimed SMALL ENTITY status before, or is now claiming SMALL ENTITY status, check box 5a on Part B - Fee(s) Transmittal and pay the PUBLICATION FEE (if required) and 1/2 the ISSUE FEE shown above.

II. PART B - FEE(S) TRANSMITTAL, or its equivalent, must be completed and returned to the United States Patent and Trademark Office (USPTO) with your ISSUE FEE and PUBLICATION FEE (if required). If you are charging the fee(s) to your deposit account, section "4b" of Part B - Fee(s) Transmittal should be completed and an extra copy of the form should be submitted. If an equivalent of Part B is filed, a request to reapply a previously paid issue fee must be clearly made, and delays in processing may occur due to the difficulty in recognizing the paper as an equivalent of Part B.

III. All communications regarding this application must give the application number. Please direct all communications prior to issuance to Mail Stop ISSUE FEE unless advised to the contrary.

IMPORTANT REMINDER: Utility patents issuing on applications filed on or after Dec. 12, 1980 may require payment of maintenance fees. It is patentee's responsibility to ensure timely payment of maintenance fees when due.

PART B - FEE(S) TRANSMITTAL

**Complete and send this form, together with applicable fee(s), to: Mail Mail Stop ISSUE FEE
 Commissioner for Patents
 P.O. Box 1450
 Alexandria, Virginia 22313-1450
 or Fax (571)-273-2885**

INSTRUCTIONS: This form should be used for transmitting the ISSUE FEE and PUBLICATION FEE (if required). Blocks 1 through 5 should be completed where appropriate. All further correspondence including the Patent, advance orders and notification of maintenance fees will be mailed to the current correspondence address as indicated unless corrected below or directed otherwise in Block 1, by (a) specifying a new correspondence address; and/or (b) indicating a separate "FEE ADDRESS" for maintenance fee notifications.

CURRENT CORRESPONDENCE ADDRESS (Note: Use Block 1 for any change of address)

Note: A certificate of mailing can only be used for domestic mailings of the Fee(s) Transmittal. This certificate cannot be used for any other accompanying papers. Each additional paper, such as an assignment or formal drawing, must have its own certificate of mailing or transmission.

7590 11/06/2012
 David S. D'Ascenzo
 DASCENZO INTELLECTUAL PROPERTY LAW, P.C.
 Suite 925
 522 S.W. 5th Avenue
 Portland, OR 97204

Certificate of Mailing or Transmission

I hereby certify that this Fee(s) Transmittal is being deposited with the United States Postal Service with sufficient postage for first class mail in an envelope addressed to the Mail Stop ISSUE FEE address above, or being facsimile transmitted to the USPTO (571) 273-2885, on the date indicated below.

(Depositor's name)
(Signature)
(Date)

APPLICATION NO.	FILING DATE	FIRST NAMED INVENTOR	ATTORNEY DOCKET NO.	CONFIRMATION NO.
-----------------	-------------	----------------------	---------------------	------------------

13/103,310 05/09/2011 Albert L. Arendt MPW 3M1B 9050

TITLE OF INVENTION: BLOW-MOLDED WHEELS HAVING UNDERCUT TREADS, METHODS FOR PRODUCING THE SAME, AND CHILDREN'S RIDE-ON VEHICLES INCLUDING THE SAME

APPLN. TYPE	SMALL ENTITY	ISSUE FEE DUE	PUBLICATION FEE DUE	PREV. PAID ISSUE FEE	TOTAL FEE(S) DUE	DATE DUE
-------------	--------------	---------------	---------------------	----------------------	------------------	----------

nonprovisional NO \$1770 \$300 \$0 \$2070 02/06/2013

EXAMINER	ART UNIT	CLASS-SUBCLASS
----------	----------	----------------

STABLEY, MICHAEL R 3611 280-029000

<p>1. Change of correspondence address or indication of "Fee Address" (37 CFR 1.363).</p> <p><input type="checkbox"/> Change of correspondence address (or Change of Correspondence Address form PTO/SB/122) attached.</p> <p><input type="checkbox"/> "Fee Address" indication (or "Fee Address" Indication form PTO/SB/47; Rev 03-02 or more recent) attached. Use of a Customer Number is required.</p>	<p>2. For printing on the patent front page, list</p> <p>(1) the names of up to 3 registered patent attorneys or agents OR, alternatively, 1 _____</p> <p>(2) the name of a single firm (having as a member a registered attorney or agent) and the names of up to 2 registered patent attorneys or agents. If no name is listed, no name will be printed. 2 _____</p> <p>3 _____</p>
---	---

3. ASSIGNEE NAME AND RESIDENCE DATA TO BE PRINTED ON THE PATENT (print or type)

PLEASE NOTE: Unless an assignee is identified below, no assignee data will appear on the patent. If an assignee is identified below, the document has been filed for recordation as set forth in 37 CFR 3.11. Completion of this form is NOT a substitute for filing an assignment.

(A) NAME OF ASSIGNEE (B) RESIDENCE: (CITY and STATE OR COUNTRY)

Please check the appropriate assignee category or categories (will not be printed on the patent) : Individual Corporation or other private group entity Government

<p>4a. The following fee(s) are submitted:</p> <p><input type="checkbox"/> Issue Fee</p> <p><input type="checkbox"/> Publication Fee (No small entity discount permitted)</p> <p><input type="checkbox"/> Advance Order - # of Copies _____</p>	<p>4b. Payment of Fee(s); (Please first reapply any previously paid issue fee shown above)</p> <p><input type="checkbox"/> A check is enclosed.</p> <p><input type="checkbox"/> Payment by credit card. Form PTO-2038 is attached.</p> <p><input type="checkbox"/> The Director is hereby authorized to charge the required fee(s), any deficiency, or credit any overpayment, to Deposit Account Number _____ (enclose an extra copy of this form).</p>
---	--

5. Change in Entity Status (from status indicated above)

a. Applicant claims SMALL ENTITY status. See 37 CFR 1.27. b. Applicant is no longer claiming SMALL ENTITY status. See 37 CFR 1.27(g)(2).

NOTE: The Issue Fee and Publication Fee (if required) will not be accepted from anyone other than the applicant; a registered attorney or agent; or the assignee or other party in interest as shown by the records of the United States Patent and Trademark Office.

Authorized Signature _____ Date _____

Typed or printed name _____ Registration No. _____

This collection of information is required by 37 CFR 1.311. The information is required to obtain or retain a benefit by the public which is to file (and by the USPTO to process) an application. Confidentiality is governed by 35 U.S.C. 122 and 37 CFR 1.14. This collection is estimated to take 12 minutes to complete, including gathering, preparing, and submitting the completed application form to the USPTO. Time will vary depending upon the individual case. Any comments on the amount of time you require to complete this form and/or suggestions for reducing this burden, should be sent to the Chief Information Officer, U.S. Patent and Trademark Office, U.S. Department of Commerce, P.O. Box 1450, Alexandria, Virginia 22313-1450. DO NOT SEND FEES OR COMPLETED FORMS TO THIS ADDRESS. SEND TO: Commissioner for Patents, P.O. Box 1450, Alexandria, Virginia 22313-1450.

Under the Paperwork Reduction Act of 1995, no persons are required to respond to a collection of information unless it displays a valid OMB control number.



UNITED STATES PATENT AND TRADEMARK OFFICE

UNITED STATES DEPARTMENT OF COMMERCE
United States Patent and Trademark Office
Address: COMMISSIONER FOR PATENTS
P.O. Box 1450
Alexandria, Virginia 22313-1450
www.uspto.gov

Table with 5 columns: APPLICATION NO., FILING DATE, FIRST NAMED INVENTOR, ATTORNEY DOCKET NO., CONFIRMATION NO.
13/103,310 05/09/2011 Albert L. Arendt MPW 3M1B 9050

7590 11/06/2012
David S. D'Ascenzo
DASCENZO INTELLECTUAL PROPERTY LAW, P.C.
Suite 925
522 S.W. 5th Avenue
Portland, OR 97204

EXAMINER

STABLEY, MICHAEL R

ART UNIT PAPER NUMBER

3611

DATE MAILED: 11/06/2012

Determination of Patent Term Adjustment under 35 U.S.C. 154 (b)

(application filed on or after May 29, 2000)

The Patent Term Adjustment to date is 0 day(s). If the issue fee is paid on the date that is three months after the mailing date of this notice and the patent issues on the Tuesday before the date that is 28 weeks (six and a half months) after the mailing date of this notice, the Patent Term Adjustment will be 0 day(s).

If a Continued Prosecution Application (CPA) was filed in the above-identified application, the filing date that determines Patent Term Adjustment is the filing date of the most recent CPA.

Applicant will be able to obtain more detailed information by accessing the Patent Application Information Retrieval (PAIR) WEB site (http://pair.uspto.gov).

Any questions regarding the Patent Term Extension or Adjustment determination should be directed to the Office of Patent Legal Administration at (571)-272-7702. Questions relating to issue and publication fee payments should be directed to the Customer Service Center of the Office of Patent Publication at 1-(888)-786-0101 or (571)-272-4200.

Privacy Act Statement

The Privacy Act of 1974 (P.L. 93-579) requires that you be given certain information in connection with your submission of the attached form related to a patent application or patent. Accordingly, pursuant to the requirements of the Act, please be advised that: (1) the general authority for the collection of this information is 35 U.S.C. 2(b)(2); (2) furnishing of the information solicited is voluntary; and (3) the principal purpose for which the information is used by the U.S. Patent and Trademark Office is to process and/or examine your submission related to a patent application or patent. If you do not furnish the requested information, the U.S. Patent and Trademark Office may not be able to process and/or examine your submission, which may result in termination of proceedings or abandonment of the application or expiration of the patent.

The information provided by you in this form will be subject to the following routine uses:

1. The information on this form will be treated confidentially to the extent allowed under the Freedom of Information Act (5 U.S.C. 552) and the Privacy Act (5 U.S.C. 552a). Records from this system of records may be disclosed to the Department of Justice to determine whether disclosure of these records is required by the Freedom of Information Act.
2. A record from this system of records may be disclosed, as a routine use, in the course of presenting evidence to a court, magistrate, or administrative tribunal, including disclosures to opposing counsel in the course of settlement negotiations.
3. A record in this system of records may be disclosed, as a routine use, to a Member of Congress submitting a request involving an individual, to whom the record pertains, when the individual has requested assistance from the Member with respect to the subject matter of the record.
4. A record in this system of records may be disclosed, as a routine use, to a contractor of the Agency having need for the information in order to perform a contract. Recipients of information shall be required to comply with the requirements of the Privacy Act of 1974, as amended, pursuant to 5 U.S.C. 552a(m).
5. A record related to an International Application filed under the Patent Cooperation Treaty in this system of records may be disclosed, as a routine use, to the International Bureau of the World Intellectual Property Organization, pursuant to the Patent Cooperation Treaty.
6. A record in this system of records may be disclosed, as a routine use, to another federal agency for purposes of National Security review (35 U.S.C. 181) and for review pursuant to the Atomic Energy Act (42 U.S.C. 218(c)).
7. A record from this system of records may be disclosed, as a routine use, to the Administrator, General Services, or his/her designee, during an inspection of records conducted by GSA as part of that agency's responsibility to recommend improvements in records management practices and programs, under authority of 44 U.S.C. 2904 and 2906. Such disclosure shall be made in accordance with the GSA regulations governing inspection of records for this purpose, and any other relevant (i.e., GSA or Commerce) directive. Such disclosure shall not be used to make determinations about individuals.
8. A record from this system of records may be disclosed, as a routine use, to the public after either publication of the application pursuant to 35 U.S.C. 122(b) or issuance of a patent pursuant to 35 U.S.C. 151. Further, a record may be disclosed, subject to the limitations of 37 CFR 1.14, as a routine use, to the public if the record was filed in an application which became abandoned or in which the proceedings were terminated and which application is referenced by either a published application, an application open to public inspection or an issued patent.
9. A record from this system of records may be disclosed, as a routine use, to a Federal, State, or local law enforcement agency, if the USPTO becomes aware of a violation or potential violation of law or regulation.

Notice of Allowability

Application No.

13/103,310

Applicant(s)

ARENDET ET AL.

Examiner

Michael Stabley

Art Unit

3611

-- The MAILING DATE of this communication appears on the cover sheet with the correspondence address--

All claims being allowable, PROSECUTION ON THE MERITS IS (OR REMAINS) CLOSED in this application. If not included herewith (or previously mailed), a Notice of Allowance (PTOL-85) or other appropriate communication will be mailed in due course. **THIS NOTICE OF ALLOWABILITY IS NOT A GRANT OF PATENT RIGHTS.** This application is subject to withdrawal from issue at the initiative of the Office or upon petition by the applicant. See 37 CFR 1.313 and MPEP 1308.

- 1. This communication is responsive to 10/8/12.
- 2. An election was made by the applicant in response to a restriction requirement set forth during the interview on ____; the restriction requirement and election have been incorporated into this action.
- 3. The allowed claim(s) is/are 2-24.
- 4. Acknowledgment is made of a claim for foreign priority under 35 U.S.C. § 119(a)-(d) or (f).
 - a) All b) Some* c) None of the:
 - 1. Certified copies of the priority documents have been received.
 - 2. Certified copies of the priority documents have been received in Application No. ____ .
 - 3. Copies of the certified copies of the priority documents have been received in this national stage application from the International Bureau (PCT Rule 17.2(a)).

* Certified copies not received: ____.

Applicant has THREE MONTHS FROM THE "MAILING DATE" of this communication to file a reply complying with the requirements noted below. Failure to timely comply will result in ABANDONMENT of this application.

THIS THREE-MONTH PERIOD IS NOT EXTENDABLE.

- 5. A SUBSTITUTE OATH OR DECLARATION must be submitted. Note the attached EXAMINER'S AMENDMENT or NOTICE OF INFORMAL PATENT APPLICATION (PTO-152) which gives reason(s) why the oath or declaration is deficient.
 - 6. CORRECTED DRAWINGS (as "replacement sheets") must be submitted.
 - (a) including changes required by the Notice of Draftsperson's Patent Drawing Review (PTO-948) attached
 - 1) hereto or 2) to Paper No./Mail Date ____.
 - (b) including changes required by the attached Examiner's Amendment / Comment or in the Office action of Paper No./Mail Date ____.
- Identifying indicia such as the application number (see 37 CFR 1.84(c)) should be written on the drawings in the front (not the back) of each sheet. Replacement sheet(s) should be labeled as such in the header according to 37 CFR 1.121(d).**
- 7. DEPOSIT OF and/or INFORMATION about the deposit of BIOLOGICAL MATERIAL must be submitted. Note the attached Examiner's comment regarding REQUIREMENT FOR THE DEPOSIT OF BIOLOGICAL MATERIAL.

Attachment(s)

- 1. Notice of References Cited (PTO-892)
- 2. Notice of Draftsperson's Patent Drawing Review (PTO-948)
- 3. Information Disclosure Statements (PTO/SB/08), Paper No./Mail Date ____
- 4. Examiner's Comment Regarding Requirement for Deposit of Biological Material
- 5. Notice of Informal Patent Application
- 6. Interview Summary (PTO-413), Paper No./Mail Date ____ .
- 7. Examiner's Amendment/Comment
- 8. Examiner's Statement of Reasons for Allowance
- 9. Other ____.

/KEVIN HURLEY/
Primary Examiner, Art Unit 3611

Search Notes 	Application/Control No. 13103310	Applicant(s)/Patent Under Reexamination ARENDR ET AL.
	Examiner MICHAEL STABLEY	Art Unit 3611

SEARCHED			
Class	Subclass	Date	Examiner
280	29	10/22/2012	MS
264	454, 501, 512, 523, 524	10/22/2012	MS
152	209.1	10/22/2012	MS

SEARCH NOTES		
Search Notes	Date	Examiner
EAST Search Results - See Attached	10/22/2012	MS
Consult Primary Kevin Hurley	10/22/2012	MS

INTERFERENCE SEARCH			
Class	Subclass	Date	Examiner
	See Attached Search Results	10/22/2012	MS

/MICHAEL STABLEY/ Examiner.Art Unit 3611	
---	--

EAST Search History

EAST Search History (Prior Art)

Ref #	Hits	Search Query	DBs	Default Operator	Plurals	Time Stamp
L1	1472	280/29.ccls. or 264/454.ccls. or 152/209.1.ccls.	US-PGPUB; USPAT; USOCR	OR	ON	2012/10/22 14:42
L2	1752	264/501.ccls. or 264/512.ccls. or 264/523.ccls. or 264/524.ccls.	US-PGPUB; USPAT; USOCR	OR	ON	2012/10/22 14:42
S1	67	("2601700" "20030085611" "20040070262" "20050056474" "3029468" "3264780" "3373460" "3592885" "3616491" "3692453" "3730658" "3779688" "3817676" "3851029" "3888545" "3907370" "3936264" "3135997" "3570057" "4063868" "4323411" "4513981" "4531704" "4588842" "4717113" "4832307" "4854849" "4884961" "4889480" "4516648" "5104198" "5219594" "5227114" "5316135" "5316377" "5368371" "5518682" "5556601" "5573129" "5736168" "5750067" "5799809" "5810452" "5908124" "5924506" "6068161" "6095543" "6170920" "6318983" "6431406" "6464305" "6520597" "6591986" "6872354" "6896335" "6913324" "6953333" "6470982").PN.	US-PGPUB; USPAT; USOCR	OR	ON	2009/01/28 11:16
S3	14	("3730594" "3894776" "4358162" "5104198" "5368371").PN. OR ("6170920").URPN.	US-PGPUB; USPAT; USOCR	OR	ON	2009/01/28 15:14
S4	325	(tire or wheel) near5 (blow adj mold\$3)	US-PGPUB; USPAT; USOCR	OR	ON	2009/01/28 15:23
S5	14	("3870372" "3960474" "4040670" "4088523" "4301850" "4722131" "5104198" "5114522" "5133591").PN. OR ("5518682").URPN.	US-PGPUB; USPAT; USOCR	OR	ON	2009/01/28 16:19
S6	18	("1560551" "1687113" "2969254" "3387894" "3870372" "4592595" "5104198" "5129709").PN. OR ("5316377").URPN.	US-PGPUB; USPAT; USOCR	OR	ON	2009/01/28 16:27
S7	14	("3870372" "3960474" "4040670" "4088523" "4301850" "4722131" "5104198" "5114522" "5133591").PN. OR ("5518682").URPN.	US-PGPUB; USPAT; USOCR	OR	ON	2009/03/20 14:14
S8	18	("1560551" "1687113" "2969254" "3387894" "3870372" "4592595"	US-PGPUB;	OR	ON	2009/03/20 14:15

		"5104198" "5129709").PN. OR ("5316377").URPN.	USPAT; USOCR			
S9	1277	280/29.ccls. or 264/454.ccls. or 152/209.1.ccls.	US- PGPUB; USPAT; USOCR	OR	ON	2009/08/03 15:49
S10	674	152/209.1.ccls.	US- PGPUB; USPAT; USOCR	OR	ON	2009/08/03 15:50
S12	72	("2601700" "20030085611" "20040070262" "20050056474" "20080006456" "3029468" "3135997" "3264780" "3373460" "3570057" "3592885" "3616491" "3692453" "3730658" "3779688" "3817676" "3851029" "3888545" "3907370" "3936264" "4063868" "4323411" "4513981" "4516648" "4531704" "4588542" "4717113" "4832307" "4854849" "4884961" "4889480" "5104198" "5219594" "5227114" "5316135" "5316377" "5368371" "5518682" "5556601" "5573129" "5736168" "5750067" "5799809" "5810452" "5879484" "5908124" "5924506" "6068161" "6095543" "6170920" "6318983" "6431406" "6446981" "6464305" "6470982" "6520597" "6591986" "6872354" "6896335" "6913324" "6953333" "7621543" "D327048").PN.	US- PGPUB; USPAT; USOCR	OR	ON	2011/10/23 12:17
S13	1411	280/29.ccls. or 264/454.ccls. or 152/209.1.ccls.	US- PGPUB; USPAT; USOCR	OR	ON	2011/10/23 12:17
S14	1650	264/501.ccls. or 264/512.ccls. or 264/523.ccls. or 264/524.ccls.	US- PGPUB; USPAT; USOCR	OR	ON	2011/10/23 12:19
S15	1650	264/501.ccls. or 264/512.ccls. or 264/523.ccls. or 264/524.ccls.	US- PGPUB; USPAT; USOCR	OR	ON	2011/10/24 10:00
S16	680	S15 and (blow adj mold\$3)	US- PGPUB; USPAT; USOCR	OR	ON	2011/10/24 10:00
S17	39	S15 and ((blow adj mold\$3) same (tire or wheel))	US- PGPUB; USPAT; USOCR	OR	ON	2011/10/24 10:01
S18	35	("1560551" "1687113" "2969254" "3387894" "3870372" "3960474" "4040670" "4088523" "4301850" "4592595" "4722131" "5104198" "5114522" "5129709" "5133591").PN. OR ("5316377" "5518682").URPN.	US- PGPUB; USPAT; USOCR	OR	ON	2011/10/24 17:08
S19	11	(US-20050056474-\$).did. or (US-6464305-\$ or US-6170920-\$ or US-5924506-\$ or US-	US- PGPUB;	OR	ON	2011/10/24 20:02

		5368371-\$ or US-6446981-\$ or US-5518682-\$ or US-5316377-\$ or US-D327048-\$ or US-5104198-\$ or US-4088523-\$).did.	USPAT			
S20	72	("2601700" "20030085611" "20040070262" "20050056474" "20080006456" "3029468" "3135997" "3264780" "3373460" "3570057" "3592885" "3616491" "3692453" "3730658" "3779688" "3817676" "3851029" "3888545" "3907370" "3936264" "4063868" "4323411" "4513981" "4516648" "4531704" "4588542" "4717113" "4832307" "4854849" "4884961" "4889480" "5104198" "5219594" "5227114" "5316135" "5316377" "5368371" "5518682" "5556601" "5573129" "5736168" "5750067" "5799809" "5810452" "5879484" "5908124" "5924506" "6068161" "6095543" "6170920" "6318983" "6431406" "6446981" "6464305" "6470982" "6520597" "6591986" "6872354" "6896335" "6913324" "6953333" "7621543" "D327048").PN.	US-PGPUB; USPAT; USOCR	OR	ON	2011/10/24 20:03
S21	1	S19 not S20	US-PGPUB; USPAT; USOCR	OR	ON	2011/10/24 20:03
S22	8	(tire or wheel) same (blow adj mold\$3) and (tread adj blocks)	US-PGPUB; USPAT; USOCR	OR	ON	2011/10/25 10:45
S23	72	("20030085611" "20040070262" "20050056474" "20080006456" "2601700" "3029468" "3135997" "3264780" "3373460" "3570057" "3592885" "3616491" "3692453" "3730658" "3779688" "3817676" "3851029" "3888545" "3907370" "3936264" "4063868" "4323411" "4513981" "4516648" "4531704" "4588542" "4717113" "4832307" "4854849" "4884961" "4889480" "5104198" "5219594" "5227114" "5316135" "5316377" "5368371" "5518682" "5556601" "5573129" "5736168" "5750067" "5799809" "5810452" "5879484" "5908124" "5924506" "6068161" "6095543" "6170920" "6318983" "6431406" "6446981" "6464305" "6470982" "6520597" "6591986" "6872354" "6896335" "6913324" "6953333" "7621543" "D327048").PN. OR ("7939008").URPN.	US-PGPUB; USPAT; USOCR	OR	ON	2011/10/25 10:57
S24	1687	264/501.ccls. or 264/512.ccls. or 264/523.ccls. or 264/524.ccls.	US-PGPUB; USPAT; USOCR	OR	ON	2012/04/10 10:04
S25	1435	280/29.ccls. or 264/454.ccls. or 152/209.1.ccls.	US-PGPUB; USPAT;	OR	ON	2012/04/10 10:04

			USOCR			
S26	772	152/209.1.ccls.	US-PGPUB; USPAT; USOCR	OR	ON	2012/04/10 10:04
S27	429	(tire or wheel) near5 (blow adj mold\$3)	US-PGPUB; USPAT; USOCR	OR	ON	2012/04/10 10:50
S28	80	S27 and child\$3	US-PGPUB; USPAT; USOCR	OR	ON	2012/04/10 10:50
S29	58	(tire or wheel) near5 (blow adj mould\$3)	US-PGPUB; USPAT; USOCR	OR	ON	2012/04/10 11:00
S30	2	S29 and child\$3	US-PGPUB; USPAT; USOCR	OR	ON	2012/04/10 11:00
S31	344	(tire or wheel) near3 (blow adj mold\$3)	US-PGPUB; USPAT; USOCR	OR	ON	2012/04/10 11:28
S32	288	S31 not S28	US-PGPUB; USPAT; USOCR	OR	ON	2012/04/10 11:29
S33	34	S32 and (vehicle or car or toy)	US-PGPUB; USPAT; USOCR	OR	ON	2012/04/10 11:30
S34	9	("3264780").URPN.	USPAT	OR	OFF	2012/04/10 11:34
S35	79	("1930835" "20030085611" "20040070262" "20050056474" "20060073289" "20060231303" "20080006456" "2601700" "3029468" "3135997" "3264780" "3373460" "3570057" "3592885" "3616491" "3692453" "3730658" "3779688" "3817676" "3851029" "3888545" "3907370" "3936264" "4063868" "4323411" "4513981" "4516648" "4531704" "4588542" "4717113" "4832307" "4854849" "4884961" "4889480" "5104198" "5219594" "5227114" "5316135" "5316377" "5368371" "5518682" "5553878" "5556601" "5573129" "5736168" "5750067" "5799809" "5810452" "5879484" "5908124" "5924506" "6068161" "6095543" "6170920" "6318983" "6431406" "6446981" "6464305" "6470982" "6520597" "6591986" "6615885" "6872354" "6896335" "6913324" "6953333" "7621543" "D327048").PN. OR ("7621543" "7905305" "7939008").URPN.	US-PGPUB; USPAT; USOCR	OR	OFF	2012/04/10 11:35
S36	72	("20030085611" "20040070262"	US-	OR	OFF	2012/04/10

		"20050056474" "20080006456" "2601700" "3029468" "3135997" "3264780" "3373460" "3570057" "3592885" "3616491" "3692453" "3730658" "3779688" "3817676" "3851029" "3888545" "3907370" "3936264" "4063868" "4323411" "4513981" "4516648" "4531704" "4588542" "4717113" "4832307" "4854849" "4884961" "4889480" "5104198" "5219594" "5227114" "5316135" "5316377" "5368371" "5518682" "5556601" "5573129" "5736168" "5750067" "5799809" "5810452" "5879484" "5908124" "5924506" "6068161" "6095543" "6170920" "6318983" "6431406" "6446981" "6464305" "6470982" "6520597" "6591986" "6872354" "6896335" "6913324" "6953333" "7621543" "D327048").PN. OR ("7939008").URPN.	PGPUB; USPAT; USOCR			11:37
S37	1459	280/29.ccls. or 264/454.ccls. or 152/209.1.ccls.	US- PGPUB; USPAT; USOCR	OR	ON	2012/08/29 20:30
S38	788	152/209.1.ccls.	US- PGPUB; USPAT; USOCR	OR	ON	2012/08/29 20:30
S39	1736	264/501.ccls. or 264/512.ccls. or 264/523.ccls. or 264/524.ccls.	US- PGPUB; USPAT; USOCR	OR	ON	2012/08/29 20:30

EAST Search History (Interference)

Ref #	Hits	Search Query	DBs	Default Operator	Plurals	Time Stamp
L3	2	(children and vehicle and body and wheel and seat and blow and molded and axis and region).clm.	USPAT; UPAD	OR	ON	2012/10/22 14:43
S11	0	(vehicle and body and wheels and molded and tread and surface and region and radial and distance and steering and assembly and drive).clm.	USPAT; UPAD	OR	ON	2009/08/03 16:05

10/22/2012 2:49:03 PM

C:\Users\mstabley\Documents\EAST\Workspaces\13103310.wsp

PART B - FEE(S) TRANSMITTAL

Complete and send this form, together with applicable fee(s), to: **Mail** Mail Stop **ISSUE FEE**
Commissioner for Patents
P.O. Box 1450
Alexandria, Virginia 22313-1450
or Fax (571)-273-2885

INSTRUCTIONS: This form should be used for transmitting the **ISSUE FEE** and **PUBLICATION FEE** (if required). Blocks 1 through 5 should be completed where appropriate. All further correspondence including the Patent, advance orders and notification of maintenance fees will be mailed to the current correspondence address as indicated unless corrected below or directed otherwise in Block 1, by (a) specifying a new correspondence address; and/or (b) indicating a separate "FEE ADDRESS" for maintenance fee notifications.

CURRENT CORRESPONDENCE ADDRESS (Note: Use Block 1 for any change of address)

Note: A certificate of mailing can only be used for domestic mailings of the Fee(s) Transmittal. This certificate cannot be used for any other accompanying papers. Each additional paper, such as an assignment or formal drawing, must have its own certificate of mailing or transmission.

Certificate of Mailing or Transmission
 I hereby certify that this Fee(s) Transmittal is being deposited with the United States Postal Service with sufficient postage for first class mail in an envelope addressed to the Mail Stop ISSUE FEE address above, or being facsimile transmitted to the USPTO (571) 273-2885, on the date indicated below.

David S. D'Ascenzo	(Depositor's name)
	(Signature)
November 30, 2012	(Date)

7590 11/06/2012
 David S. D'Ascenzo
 DASCENZO INTELLECTUAL PROPERTY LAW, P.C.
 Suite 925
 522 S.W. 5th Avenue
 Portland, OR 97204

APPLICATION NO.	FILING DATE	FIRST NAMED INVENTOR	ATTORNEY DOCKET NO.	CONFIRMATION NO.
13/103,310	05/09/2011	Albert L. Arendt	MPW 3M1B	9050

TITLE OF INVENTION: BLOW-MOLDED WHEELS HAVING UNDERCUT TREADS, METHODS FOR PRODUCING THE SAME, AND CHILDREN'S RIDE-ON VEHICLES INCLUDING THE SAME

APPLN. TYPE	SMALL ENTITY	ISSUE FEE DUE	PUBLICATION FEE DUE	PREV. PAID ISSUE FEE	TOTAL FEE(S) DUE	DATE DUE
nonprovisional	NO	\$1770	\$300	\$0	\$2070	02/06/2013

EXAMINER	ART UNIT	CLASS-SUBCLASS
STABLEY, MICHAEL R	3611	280-029000

1. Change of correspondence address or indication of "Fee Address" (37 CFR 1.363). <input type="checkbox"/> Change of correspondence address (or Change of Correspondence Address Form PTO/SB/122) attached. <input type="checkbox"/> "Fee Address" indication (or "Fee Address" Indication form PTO/SB/47; Rev 03-02 or more recent) attached. Use of a Customer Number is required.	2. For printing on the patent front page, list (1) the names of up to 3 registered patent attorneys or agents OR, alternatively, (2) the name of a single firm (having as a member a registered attorney or agent) and the names of up to 2 registered patent attorneys or agents. If no name is listed, no name will be printed.	DASCENZO Intellectual
		1 Property Law, P.C.
		2 _____
		3 _____

3. ASSIGNEE NAME AND RESIDENCE DATA TO BE PRINTED ON THE PATENT (print or type)
 PLEASE NOTE: Unless an assignee is identified below, no assignee data will appear on the patent. If an assignee is identified below, the document has been filed for recordation as set forth in 37 CFR 3.11. Completion of this form is NOT a substitute for filing an assignment.

(A) NAME OF ASSIGNEE: Mattel, Inc. (B) RESIDENCE: (CITY and STATE OR COUNTRY) El Segundo, California

Please check the appropriate assignee category or categories (will not be printed on the patent): Individual Corporation or other private group entity Government

4a. The following fee(s) are submitted:
 Issue Fee
 Publication Fee (No small entity discount permitted)
 Advance Order - # of Copies _____

4b. Payment of Fee(s): (Please first reapply any previously paid issue fee shown above)
 A check is enclosed.
 Payment by credit card. Form PTO-2038 is attached.
 The Director is hereby authorized to charge the required fee(s), any deficiency, or credit any overpayment, to Deposit Account Number 50-4551 (enclose an extra copy of this form).

5. Change in Entity Status (from status indicated above)
 a. Applicant claims SMALL ENTITY status. See 37 CFR 1.27. b. Applicant is no longer claiming SMALL ENTITY status. See 37 CFR 1.27(g)(2).

NOTE: The Issue Fee and Publication Fee (if required) will not be accepted from anyone other than the applicant; a registered attorney or agent; or the assignee or other party in interest as shown by the records of the United States Patent and Trademark Office.

Authorized Signature: Date: November 30, 2012
 Typed or printed name: David S. D'Ascenzo Registration No. 39,952

This collection of information is required by 37 CFR 1.311. The information is required to obtain or retain a benefit by the public which is to file (and by the USPTO to process) an application. Confidentiality is governed by 35 U.S.C. 122 and 37 CFR 1.14. This collection is estimated to take 12 minutes to complete, including gathering, preparing, and submitting the completed application form to the USPTO. Time will vary depending upon the individual case. Any comments on the amount of time you require to complete this form and/or suggestions for reducing this burden, should be sent to the Chief Information Officer, U.S. Patent and Trademark Office, U.S. Department of Commerce, P.O. Box 1450, Alexandria, Virginia 22313-1450. DO NOT SEND FEES OR COMPLETED FORMS TO THIS ADDRESS. SEND TO: Commissioner for Patents, P.O. Box 1450, Alexandria, Virginia 22313-1450.

Under the Paperwork Reduction Act of 1995, no persons are required to respond to a collection of information unless it displays a valid OMB control number.

Electronic Patent Application Fee Transmittal

Application Number:	13103310
Filing Date:	09-May-2011
Title of Invention:	BLOW-MOLDED WHEELS HAVING UNDERCUT TREADS, METHODS FOR PRODUCING THE SAME, AND CHILDREN'S RIDE-ON VEHICLES INCLUDING THE SAME
First Named Inventor/Applicant Name:	Albert L. Arendt
Filer:	David S. D'Ascenzo/Robin Davin
Attorney Docket Number:	MPW 3M1B

Filed as Large Entity

Utility under 35 USC 111(a) Filing Fees

Description	Fee Code	Quantity	Amount	Sub-Total in USD(\$)
Basic Filing:				
Pages:				
Claims:				
Miscellaneous-Filing:				
Petition:				
Patent-Appeals-and-Interference:				
Post-Allowance-and-Post-Issuance:				
Utility Appl issue fee	1501	1	1770	1770
Publ. Fee- early, voluntary, or normal	1504	1	300	300

Description	Fee Code	Quantity	Amount	Sub-Total in USD(\$)
Extension-of-Time:				
Miscellaneous:				
Total in USD (\$)				2070

Electronic Acknowledgement Receipt

EFS ID:	14350841
Application Number:	13103310
International Application Number:	
Confirmation Number:	9050
Title of Invention:	BLOW-MOLDED WHEELS HAVING UNDERCUT TREADS, METHODS FOR PRODUCING THE SAME, AND CHILDREN'S RIDE-ON VEHICLES INCLUDING THE SAME
First Named Inventor/Applicant Name:	Albert L. Arendt
Correspondence Address:	David S. D'Ascenzo DASCENZO INTELLECTUAL PROPERTY LAW, P.C. Suite 925 522 S.W. 5th Avenue Portland OR 97204 US 5032247529 david@dascenzoiplaw.com
Filer:	David S. D'Ascenzo/Robin Davin
Filer Authorized By:	David S. D'Ascenzo
Attorney Docket Number:	MPW 3M1B
Receipt Date:	30-NOV-2012
Filing Date:	09-MAY-2011
Time Stamp:	13:10:42
Application Type:	Utility under 35 USC 111(a)

Payment information:

Submitted with Payment	yes
Payment Type	Deposit Account
Payment was successfully received in RAM	\$2070

RAM confirmation Number	11676
Deposit Account	504551
Authorized User	

The Director of the USPTO is hereby authorized to charge indicated fees and credit any overpayment as follows:

Charge any Additional Fees required under 37 C.F.R. Section 1.21 (Miscellaneous fees and charges)

File Listing:

Document Number	Document Description	File Name	File Size(Bytes)/ Message Digest	Multi Part /.zip	Pages (if appl.)
1	Issue Fee Payment (PTO-85B)	Issue_Fee_Transmittal_MPW3 M1B_11-30-12.pdf	132387 6d7232a70848c6c90036d16470d27119e008c599	no	1

Warnings:

Information:

2	Fee Worksheet (SB06)	fee-info.pdf	32029 3842c71564967640696a5e266f3fd2b54d4a4e96	no	2
---	----------------------	--------------	---	----	---

Warnings:

Information:

Total Files Size (in bytes):	164416
-------------------------------------	--------

This Acknowledgement Receipt evidences receipt on the noted date by the USPTO of the indicated documents, characterized by the applicant, and including page counts, where applicable. It serves as evidence of receipt similar to a Post Card, as described in MPEP 503.

New Applications Under 35 U.S.C. 111

If a new application is being filed and the application includes the necessary components for a filing date (see 37 CFR 1.53(b)-(d) and MPEP 506), a Filing Receipt (37 CFR 1.54) will be issued in due course and the date shown on this Acknowledgement Receipt will establish the filing date of the application.

National Stage of an International Application under 35 U.S.C. 371

If a timely submission to enter the national stage of an international application is compliant with the conditions of 35 U.S.C. 371 and other applicable requirements a Form PCT/DO/EO/903 indicating acceptance of the application as a national stage submission under 35 U.S.C. 371 will be issued in addition to the Filing Receipt, in due course.

New International Application Filed with the USPTO as a Receiving Office

If a new international application is being filed and the international application includes the necessary components for an international filing date (see PCT Article 11 and MPEP 1810), a Notification of the International Application Number and of the International Filing Date (Form PCT/RO/105) will be issued in due course, subject to prescriptions concerning national security, and the date shown on this Acknowledgement Receipt will establish the international filing date of the application.



APPLICATION NO.	ISSUE DATE	PATENT NO.	ATTORNEY DOCKET NO.	CONFIRMATION NO.
13/103,310	01/08/2013	8348285	MPW 3M1B	9050

7590 12/18/2012

David S. D'Ascenzo
DASCENZO INTELLECTUAL PROPERTY LAW, P.C.
Suite 925
522 S.W. 5th Avenue
Portland, OR 97204

ISSUE NOTIFICATION

The projected patent number and issue date are specified above.

Determination of Patent Term Adjustment under 35 U.S.C. 154 (b) (application filed on or after May 29, 2000)

The Patent Term Adjustment is 0 day(s). Any patent to issue from the above-identified application will include an indication of the adjustment on the front page.

If a Continued Prosecution Application (CPA) was filed in the above-identified application, the filing date that determines Patent Term Adjustment is the filing date of the most recent CPA.

Applicant will be able to obtain more detailed information by accessing the Patent Application Information Retrieval (PAIR) WEB site (<http://pair.uspto.gov>).

Any questions regarding the Patent Term Extension or Adjustment determination should be directed to the Office of Patent Legal Administration at (571)-272-7702. Questions relating to issue and publication fee payments should be directed to the Application Assistance Unit (AAU) of the Office of Data Management (ODM) at (571)-272-4200.

APPLICANT(s) (Please see PAIR WEB site <http://pair.uspto.gov> for additional applicants):

Albert L. Arendt, West Seneca, NY;
James R. Carducci, East Aurora, NY;
Christopher F. Lucas, Cheektowaga, NY;

The United States represents the largest, most dynamic marketplace in the world and is an unparalleled location for business investment, innovation, and commercialization of new technologies. The USA offers tremendous resources and advantages for those who invest and manufacture goods here. Through SelectUSA, our nation works to encourage and facilitate business investment. To learn more about why the USA is the best country in the world to develop technology, manufacture products, and grow your business, visit SelectUSA.gov.

IN THE UNITED STATES PATENT AND TRADEMARK OFFICE

January 29, 2013

Atty. Docket No.: MPW 3M1B

In re Patent of:
Mattel, Inc.

Inventors : ALBERT L. ARENDT, JAMES R. CARDUCCI and
CHRISTOPHER F. LUCAS

Serial No. : 13/103,310

Filed : May 9, 2011

Patent No. : 8,348,285

Issued : January 8, 2013

For : BLOW-MOLDED WHEELS HAVING UNDERCUT TREADS,
METHODS FOR PRODUCING THE SAME, AND CHILDREN'S
RIDE-ON VEHICLES INCLUDING THE SAME

Attn: Certificate of Corrections Branch
Commissioner for Patents
P.O. Box 1450
Alexandria, Virginia 22313-1450

REQUEST FOR CERTIFICATE OF CORRECTION

Attached for entry in connection with the above-identified patent is a Certificate of Correction to correct a typographical error made by Patentees. Specifically, in claim 21 in column 22, line 62, "wherein fourth region" should be "wherein **the** fourth region." Our payment in the amount of \$100.00 for payment of the correction fee is being submitted via the EFS-Web. The undersigned requests that the correction be made on the patent and that a copy of the Certificate of Correction be sent to the undersigned at the address listed below.

The undersigned may be reached at the number listed below if there are any remaining issues or questions.

CERTIFICATE OF E-FILING

I hereby certify that this correspondence and the accompanying Certificate of Correction form are being transmitted electronically via the United States Patent and Trademark Office's EFS-Web System on January 29, 2013.



David S. D'Ascenzo

Respectfully submitted,

DASCENZO INTELLECTUAL
PROPERTY LAW, P.C.



David S. D'Ascenzo
Registration No. 39,952
Customer No. 78569
DASCENZO INTELLECTUAL
PROPERTY LAW, P.C.
522 S.W. 5th Ave, Suite 925
Portland, Oregon 97204
Telephone: (503) 224-7529
Facsimile: (503) 224-7329

**UNITED STATES PATENT AND TRADEMARK OFFICE
CERTIFICATE OF CORRECTION**Page 1 of 1

PATENT NO. : 8,348,285

APPLICATION NO.: 13/103,310

ISSUE DATE : January 8, 2013

INVENTOR(S) : Albert L. Arendt, James R. Carducci, and Christopher F. Lucas

It is certified that an error appears or errors appear in the above-identified patent and that said Letters Patent is hereby corrected as shown below:

Column 22, line 62, claim 21, after "the second region, and wherein" please insert --the--.

MAILING ADDRESS OF SENDER (Please do not use customer number below):

DASCENZO Intellectual Property, Law, P.C.
522 SW 5th Avenue, Suite 925
Portland, Oregon 97204

This collection of information is required by 37 CFR 1.322, 1.323, and 1.324. The information is required to obtain or retain a benefit by the public which is to file (and by the USPTO to process) an application. Confidentiality is governed by 35 U.S.C. 122 and 37 CFR 1.14. This collection is estimated to take 1.0 hour to complete, including gathering, preparing, and submitting the completed application form to the USPTO. Time will vary depending upon the individual case. Any comments on the amount of time you require to complete this form and/or suggestions for reducing this burden, should be sent to the Chief Information Officer, U.S. Patent and Trademark Office, U.S. Department of Commerce, P.O. Box 1450, Alexandria, VA 22313-1450. DO NOT SEND FEES OR COMPLETED FORMS TO THIS ADDRESS. SEND TO: **Attention Certificate of Corrections Branch, Commissioner for Patents, P.O. Box 1450, Alexandria, VA 22313-1450.**

If you need assistance in completing the form, call 1-800-PTO-9199 and select option 2.

Electronic Patent Application Fee Transmittal

Application Number:	13103310
Filing Date:	09-May-2011
Title of Invention:	BLOW-MOLDED WHEELS HAVING UNDERCUT TREADS, METHODS FOR PRODUCING THE SAME, AND CHILDREN'S RIDE-ON VEHICLES INCLUDING THE SAME
First Named Inventor/Applicant Name:	Albert L. Arendt
Filer:	David S. D'Ascenzo/Robin Davin
Attorney Docket Number:	MPW 3M1B

Filed as Large Entity

Utility under 35 USC 111(a) Filing Fees

Description	Fee Code	Quantity	Amount	Sub-Total in USD(\$)
Basic Filing:				
Pages:				
Claims:				
Miscellaneous-Filing:				
Petition:				
Patent-Appeals-and-Interference:				
Post-Allowance-and-Post-Issuance:				
Certificate of correction	1811	1	100	100

Extension-of-Time:

234 of 241

Description	Fee Code	Quantity	Amount	Sub-Total in USD(\$)
Miscellaneous:				
Total in USD (\$)				100

Electronic Acknowledgement Receipt

EFS ID:	14816394
Application Number:	13103310
International Application Number:	
Confirmation Number:	9050
Title of Invention:	BLOW-MOLDED WHEELS HAVING UNDERCUT TREADS, METHODS FOR PRODUCING THE SAME, AND CHILDREN'S RIDE-ON VEHICLES INCLUDING THE SAME
First Named Inventor/Applicant Name:	Albert L. Arendt
Correspondence Address:	David S. D'Ascenzo DASCENZO INTELLECTUAL PROPERTY LAW, P.C. Suite 925 522 S.W. 5th Avenue Portland OR 97204 US 5032247529 david@dascenzoiplaw.com
Filer:	David S. D'Ascenzo/Robin Davin
Filer Authorized By:	David S. D'Ascenzo
Attorney Docket Number:	MPW 3M1B
Receipt Date:	29-JAN-2013
Filing Date:	09-MAY-2011
Time Stamp:	11:45:00
Application Type:	Utility under 35 USC 111(a)

Payment information:

Submitted with Payment	yes
Payment Type	Deposit Account
Payment was successfully received in RAM	\$100

RAM confirmation Number	12935
Deposit Account	504551
Authorized User	

The Director of the USPTO is hereby authorized to charge indicated fees and credit any overpayment as follows:

Charge any Additional Fees required under 37 C.F.R. Section 1.21 (Miscellaneous fees and charges)

File Listing:

Document Number	Document Description	File Name	File Size(Bytes)/ Message Digest	Multi Part /.zip	Pages (if appl.)
1	Request for Certificate of Correction	Request_for_Certificate_of_Correction_MPW3M1B_1-29-13.pdf	76973 6c6f17a9de5a9640a30ff33fadce78a51c0f3f18	no	3

Warnings:

Information:

2	Fee Worksheet (SB06)	fee-info.pdf	30140 6e58d4194ace2394e59d601cfeeb76352cbdb63e	no	2
---	----------------------	--------------	---	----	---

Warnings:

Information:

Total Files Size (in bytes):	107113
-------------------------------------	--------

This Acknowledgement Receipt evidences receipt on the noted date by the USPTO of the indicated documents, characterized by the applicant, and including page counts, where applicable. It serves as evidence of receipt similar to a Post Card, as described in MPEP 503.

New Applications Under 35 U.S.C. 111

If a new application is being filed and the application includes the necessary components for a filing date (see 37 CFR 1.53(b)-(d) and MPEP 506), a Filing Receipt (37 CFR 1.54) will be issued in due course and the date shown on this Acknowledgement Receipt will establish the filing date of the application.

National Stage of an International Application under 35 U.S.C. 371

If a timely submission to enter the national stage of an international application is compliant with the conditions of 35 U.S.C. 371 and other applicable requirements a Form PCT/DO/EO/903 indicating acceptance of the application as a national stage submission under 35 U.S.C. 371 will be issued in addition to the Filing Receipt, in due course.

New International Application Filed with the USPTO as a Receiving Office

If a new international application is being filed and the international application includes the necessary components for an international filing date (see PCT Article 11 and MPEP 1810), a Notification of the International Application Number and of the International Filing Date (Form PCT/RO/105) will be issued in due course, subject to prescriptions concerning national security, and the date shown on this Acknowledgement Receipt will establish the international filing date of the application.

UNITED STATES PATENT AND TRADEMARK OFFICE
CERTIFICATE OF CORRECTION

PATENT NO. : 8,348,285 B2
APPLICATION NO. : 13/103310
DATED : January 8, 2013
INVENTOR(S) : Albert L. Arendt, James R. Carducci and Christopher F. Lucas

Page 1 of 1

It is certified that error appears in the above-identified patent and that said Letters Patent is hereby corrected as shown below:

Column 22, line 62, claim 21, after “the second region, and wherein” please insert --the--.

Signed and Sealed this
Twenty-sixth Day of February, 2013



Teresa Stanek Rea
Acting Director of the United States Patent and Trademark Office

Under the Paperwork Reduction Act of 1995, no persons are required to respond to a collection of information unless it displays a valid OMB control number.

CHANGE OF CORRESPONDENCE ADDRESS <i>Patent</i> Address to: Mail Stop Post Issue Commissioner for Patents P.O. Box 1450 Alexandria, VA 22313-1450	Patent Number	8,348,285
	Issue Date	January 8, 2013
	Application Number	13/103,310
	Filing Date	May 9, 2011
	First Named Inventor	Albert L. Arendt
	Attorney Docket Number	MPW 3M1B

Please change the Correspondence Address for the above-identified patent to:

The address associated with Customer Number: 78569

OR

Firm or Individual Name

Address

City	State	ZIP
Country		
Telephone	Email	

This form cannot be used to change the data associated with a Customer Number. To change the data associated with an existing Customer Number use "Request for Customer Number Data Change" (PTO/SB/124).

This form will not affect any "fee address" provided for the above-identified patent. To change a "fee address" use the "Fee Address Indication Form" (PTO/SB/47).

I am the:

- Patentee.
- Assignee of record of the entire interest. See 37 CFR 3.71. Statement under 37 CFR 3.73(b) is enclosed. (Form PTO/SB/96).
- Attorney or agent of record. Registration Number 39,952

Signature 

Typed or Printed Name David S. D'Ascenzo

Date June 13, 2014

Telephone (503) 224-7529

NOTE: Signatures of all the inventors or assignees of record of the entire interest or their representative(s) are required. Submit multiple forms if more than one signature is required, see below*.

*Total of 1 forms are submitted.

This collection of information is required by 37 CFR 1.33. The information is required to obtain or retain a benefit by the public which is to file (and by the USPTO to process) an application. Confidentiality is governed by 35 U.S.C. 122 and 37 CFR 1.11 and 1.14. This collection is estimated to take 3 minutes to complete, including gathering, preparing, and submitting the completed application form to the USPTO. Time will vary depending upon the individual case. Any comments on the amount of time you require to complete this form and/or suggestions for reducing this burden, should be sent to the Chief Information Officer, U.S. Patent and Trademark Office, U.S. Department of Commerce, P.O. Box 1450, Alexandria, VA 22313-1450. DO NOT SEND FEES OR COMPLETED FORMS TO THIS ADDRESS. **SEND TO: Mail Stop Post Issue, Commissioner for Patents, P.O. Box 1450, Alexandria, VA 22313-1450.**

If you need assistance in completing the form, call 1-800-PTO-9199 and select option 2.

Electronic Acknowledgement Receipt

EFS ID:	19299519
Application Number:	13103310
International Application Number:	
Confirmation Number:	9050
Title of Invention:	BLOW-MOLDED WHEELS HAVING UNDERCUT TREADS, METHODS FOR PRODUCING THE SAME, AND CHILDREN'S RIDE-ON VEHICLES INCLUDING THE SAME
First Named Inventor/Applicant Name:	Albert L. Arendt
Correspondence Address:	David S. D'Ascenzo DASCENZO INTELLECTUAL PROPERTY LAW, P.C. Suite 925 522 S.W. 5th Avenue Portland OR 97204 US 5032247529 david@dascenzoiplaw.com
Filer:	David S. D'Ascenzo/Robin Davin
Filer Authorized By:	David S. D'Ascenzo
Attorney Docket Number:	MPW 3M1B
Receipt Date:	13-JUN-2014
Filing Date:	09-MAY-2011
Time Stamp:	14:09:41
Application Type:	Utility under 35 USC 111(a)

Payment information:

Submitted with Payment	no
------------------------	----

File Listing:

Document Number	Document Description	File Name	File Size(Bytes)/ Message Digest	Multi Part /.zip	Pages (if appl.)
1	Change of Address	Change_of_Correspondence_Address_MPW3M1B_6-13-14.pdf	99476 dcf63fcc2f5222e0dee625758889c7ec5a8daf13	no	1

Warnings:

Information:

Total Files Size (in bytes):	99476
-------------------------------------	-------

This Acknowledgement Receipt evidences receipt on the noted date by the USPTO of the indicated documents, characterized by the applicant, and including page counts, where applicable. It serves as evidence of receipt similar to a Post Card, as described in MPEP 503.

New Applications Under 35 U.S.C. 111

If a new application is being filed and the application includes the necessary components for a filing date (see 37 CFR 1.53(b)-(d) and MPEP 506), a Filing Receipt (37 CFR 1.54) will be issued in due course and the date shown on this Acknowledgement Receipt will establish the filing date of the application.

National Stage of an International Application under 35 U.S.C. 371

If a timely submission to enter the national stage of an international application is compliant with the conditions of 35 U.S.C. 371 and other applicable requirements a Form PCT/DO/EO/903 indicating acceptance of the application as a national stage submission under 35 U.S.C. 371 will be issued in addition to the Filing Receipt, in due course.

New International Application Filed with the USPTO as a Receiving Office

If a new international application is being filed and the international application includes the necessary components for an international filing date (see PCT Article 11 and MPEP 1810), a Notification of the International Application Number and of the International Filing Date (Form PCT/RO/105) will be issued in due course, subject to prescriptions concerning national security, and the date shown on this Acknowledgement Receipt will establish the international filing date of the application.