



US005173591A

United States Patent [19]

[11] **Patent Number:** 5,173,591

Perego

[45] **Date of Patent:** Dec. 22, 1992

[54] **ELECTRIC GEARSHIFT FOR CHILDREN'S CARS**

4,639,646 1/1987 Harris et al. 318/139
4,736,648 4/1988 Perego 318/109

[75] **Inventor:** Gianluca Perego, Arcore, Italy

Primary Examiner—J. R. Scott
Attorney, Agent, or Firm—McGlew and Tuttle

[73] **Assignee:** Peg Perego Pines S.p.A., Milan, Italy

[21] **Appl. No.:** 696,350

[22] **Filed:** May 6, 1991

[57] **ABSTRACT**

[30] **Foreign Application Priority Data**

Jun. 29, 1990 [IT] Italy 21423/90[U]

An electric gearshift device (10) for an electric car for children has a lever (12) which can be operated manually to give different electrical connections between an electric motor and sets of batteries, so as to achieve different running conditions. In particular, the device (10) comprises a first two-speed electric selector switch (16) and a second electric reversing switch (15). The lever (12) is movable from a first to a second position to control the movement of the first switch (16), in the second position acting on the first switch (16) with elastically yieldable thrust surfaces (24) to enable the lever (12) to pass said second control position and reach a third position in which it actuates the second switch (15).

[51] **Int. Cl.⁵** H01H 9/00; H02P 1/08

[52] **U.S. Cl.** 200/61.88; 200/1 V;
318/139; 318/280

[58] **Field of Search** 200/1 V, 61.85-61.91;
318/109, 139, 280

[56] **References Cited**

U.S. PATENT DOCUMENTS

4,360,718 11/1982 Schobinger et al. 200/61.88
4,401,866 8/1983 Kaminski et al. 200/61.88
4,429,196 1/1984 Beig et al. 200/61.88 X

19 Claims, 3 Drawing Sheets

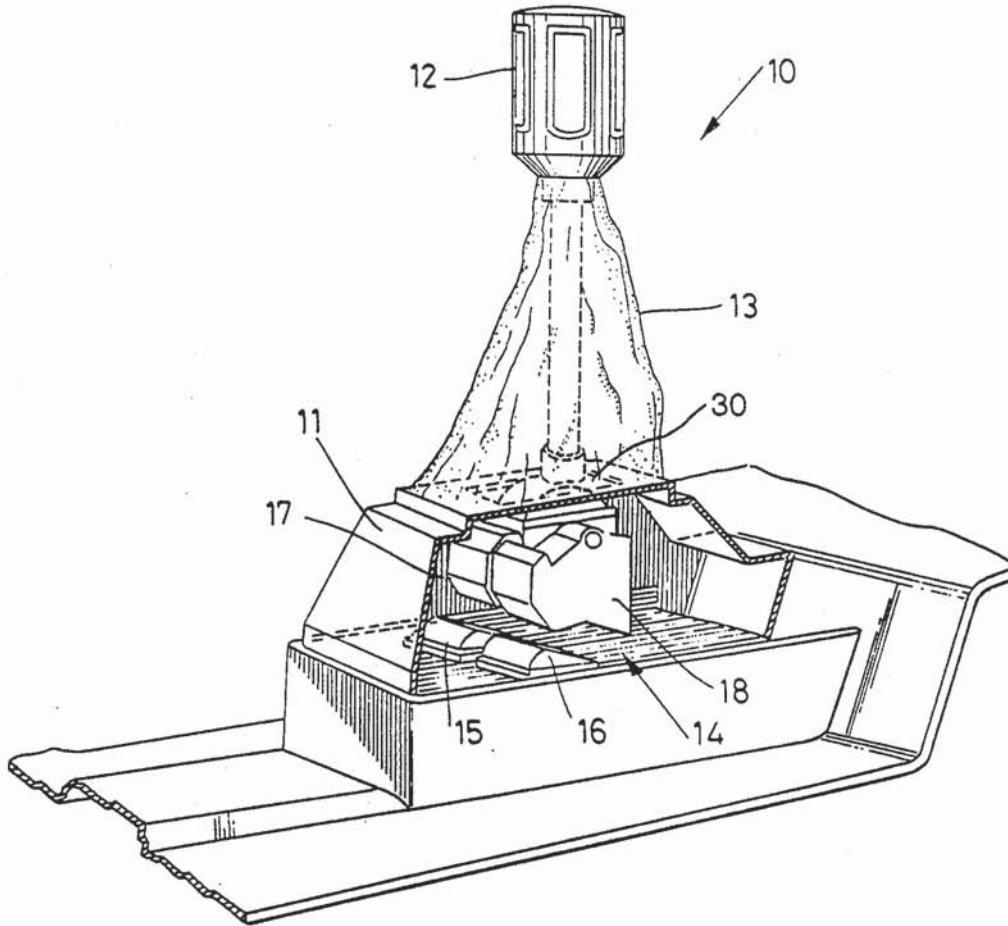

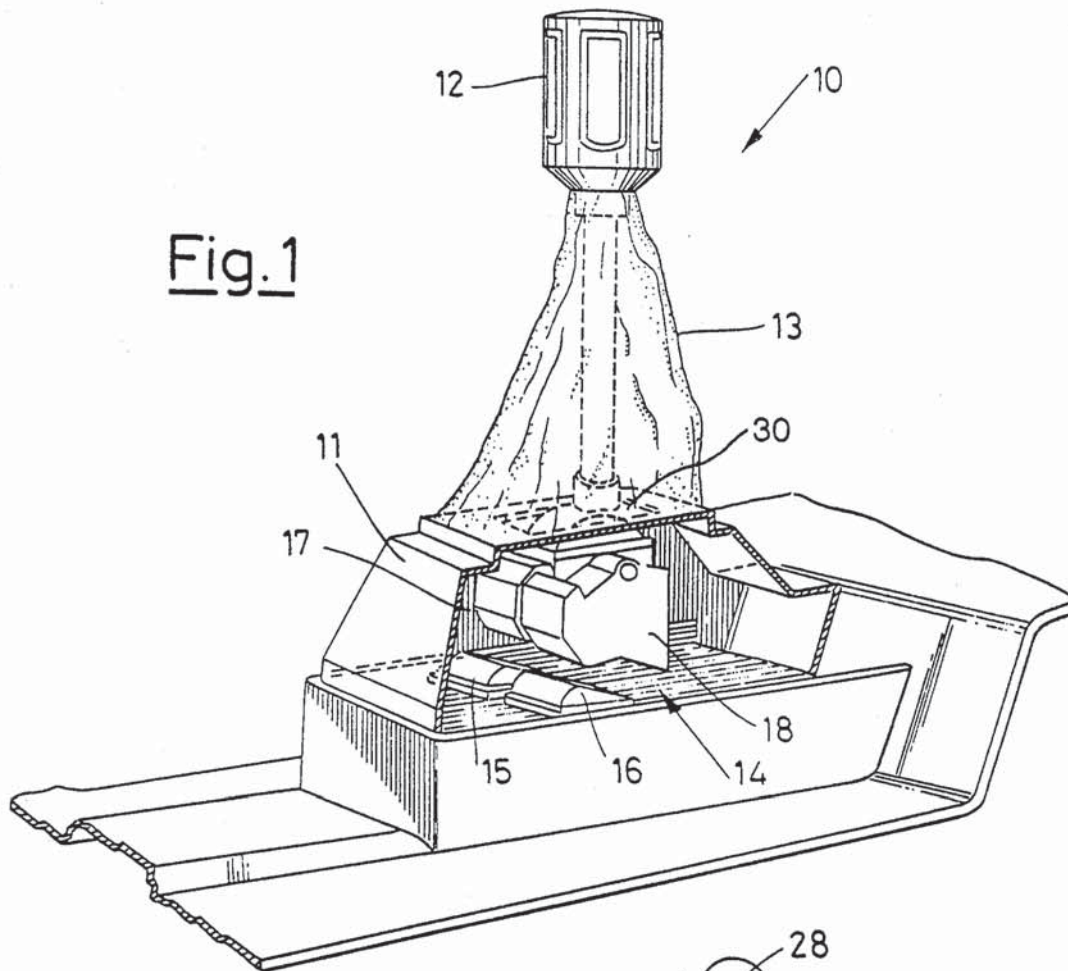
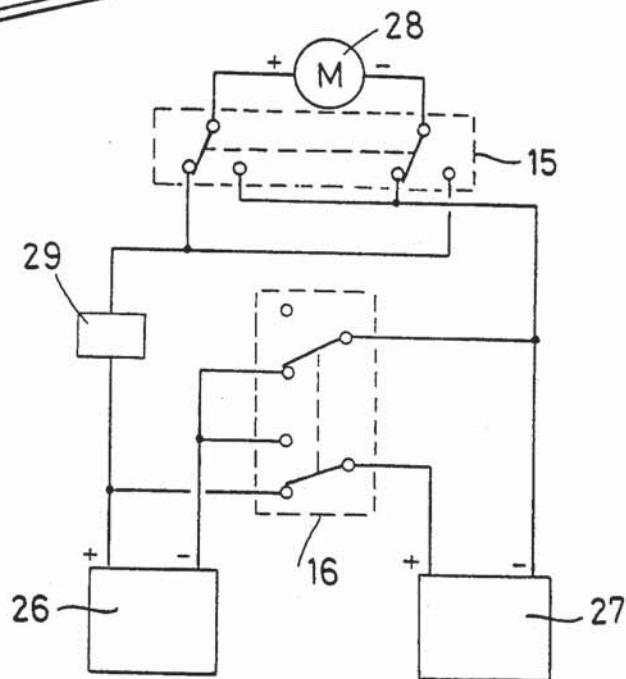

Fig. 6



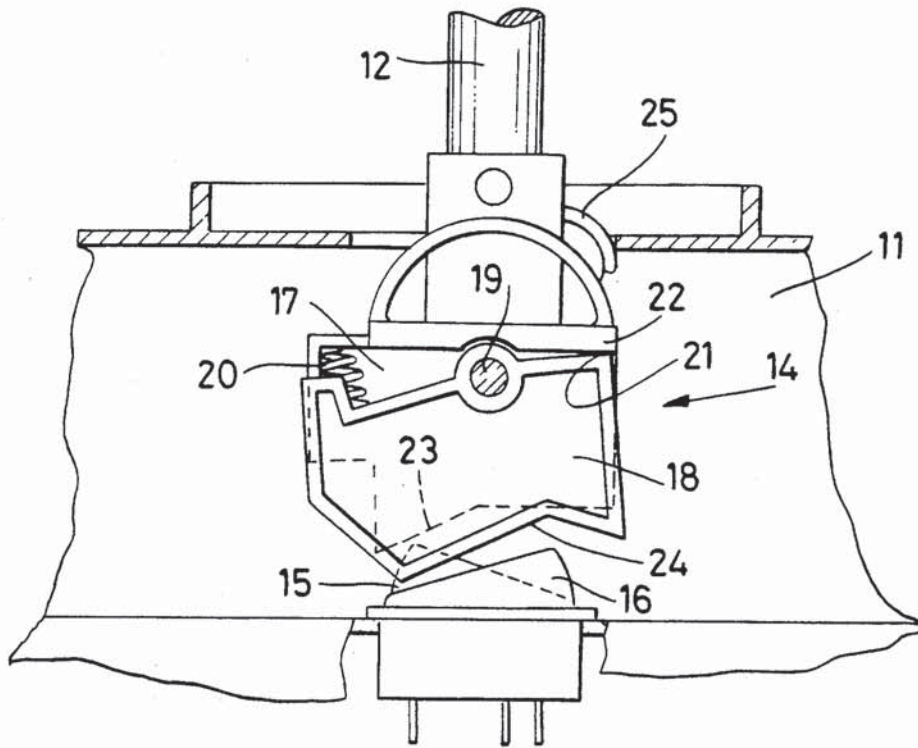

Fig. 2

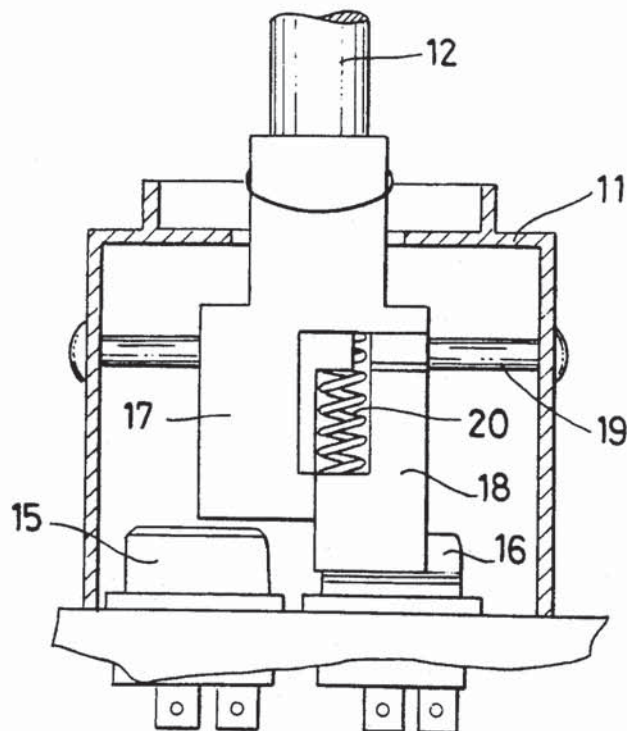

Fig. 3

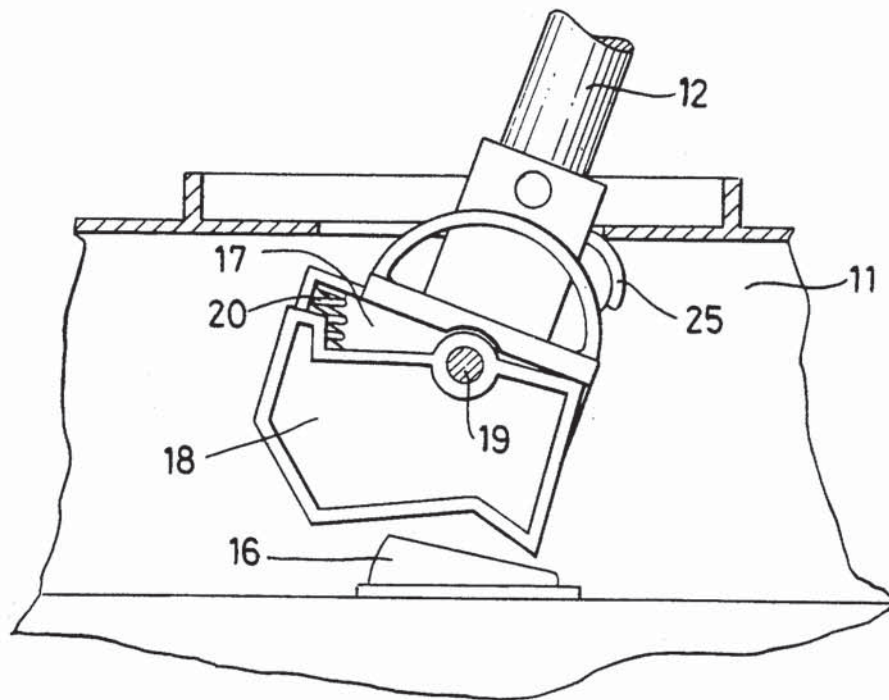

Fig. 4

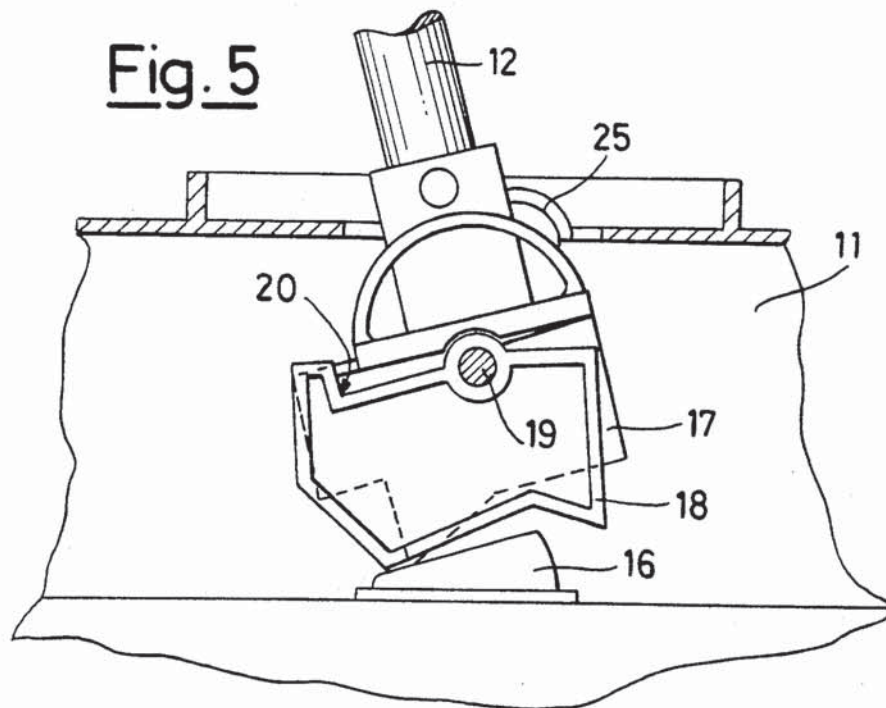

Fig. 5

ELECTRIC GEARSHIFT FOR CHILDREN'S CARS**FIELD OF THE INVENTION**

This invention refers to a gearshift suitable for electric cars for children.

BACKGROUND OF THE INVENTION

In the manufacture of such cars it is advantageous to provide an electric gearshift device by which it is possible to obtain two forward "speeds" and one reverse.

SUMMARY AND OBJECTS OF THE INVENTION

The general scope of this invention is to provide a gearshift which has the aforesaid features and is simple and economical to manufacture.

This scope is achieved, according to the invention, by providing an electric gearshift device 10 for an electric car for children, of the type which can be operated manually to provide different electrical connections between an electric motor and sets of batteries. These different electrical connections correspond to different running conditions, and are implemented by a first two-speed electric selector switch 16, a second electric reversing switch 15 and a lever 12 which is movable from a first to a second position to control the movement of the first switch 16. In the second position the lever 12 acts on the first switch 16 with elastically yieldable thrust surfaces 24 to enable the lever 12 to pass the second position in which it controls the first switch 16 and reach a third position in which it actuates the second switch 15.

The innovatory principles of this invention and its advantages with respect to the known technique will be more clearly evident from the following description of a possible exemplificative and non-restrictive embodiment applying such principles.

BRIEF DESCRIPTION OF THE DRAWINGS

In the drawings:

FIG. 1 shows a schematic perspective partial phantom view of an electric gearshift made according to this invention;

FIG. 2 shows a partial cross-sectional view of the gearshift of FIG. 1;

FIG. 3 shows a cross-sectional view of the gearshift of FIG. 2;

FIG. 4 shows a side view of the gearshift of FIG. 2 shifted to a different gear;

FIG. 5 shows a side view of the gearshift of FIG. 2 shifted to reverse;

FIG. 6 shows an example of a basic wiring diagram for use of the gearshift described herein.

DETAILED DESCRIPTION OF THE PREFERRED EMBODIMENT

With reference to the Figures, a gearshift, made according to the invention and generally indicated by reference 10, comprises a box-shaped casing 11, secured to the electric car. From the top of the casing 11, protrudes a control lever 12, covered, if necessary, with a flexible sheath 13 (for example, made of rubber).

The lever 12 is connected from below to an actuating element 14 which controls electric switches 15 and 16. As can be more clearly seen in FIGS. 2 and 3, the actuating element 14 comprises a first or fixed portion 17, integral with the lever 12 and pivoted to the walls of the

box 11 by means of a pivot or shaft 19 on which is rotatively disposed a second or yield portion 18.

Disposed between the two portions 17 and 18 is a thrust spring 20. The portion 18 has a corner 21 at the end opposite that of the pivot or shaft which strikes against a protrusion 22 on the portion 17.

As can also be clearly seen in FIG. 2, the lower part of the portion 17 comprises slating surfaces 23 and the portion 18 comprises slanting surfaces 24 for respectively operating switches 15 and 16 of the rocker type normally operated by hand. In particular, the switch 16 is of the type with two fixed positions, while the switch 15 is of the pushbutton or momentary type, that is to say, with only one fixed position (the one shown in FIG. 2).

The upper part of the element 17 has a curved sliding surface 25 which frictionally slides on the edge of the aperture 30 and through which the lever 12 passes through the casing 11. When used, the lever can be shifted to and from the extreme positions shown in FIGS. 4 and 5.

The forward or first position (or turned in a clockwise direction as shown in FIG. 4) is stably balanced thanks to the engagement of the surface 25 with the edge of the casing 11. During the movement to reach the forward or first position the element 18 is pushed by contact with element 17 so that the slanting surface 24 operate the switch 16 to shift it to its other position. The surfaces 23 on the contrary do not come into contact or interfere with the switch 15 during the movement to the forward or first positions as shown in FIG. 4.

When shifting from the forward or first position, in the opposite direction to the second or central position of lever 12 as shown in FIG. 2, the slanting surface 24 return the switch 16 to its original or second position (FIG. 2). For this purpose the force of the spring 20 must be greater than the force necessary to switch the switch.

When the lever is shifted towards the reverse or third position (or in an anticlockwise direction as shown in FIG. 5) the spring 20 compresses due to the impossibility of the element 18 to rotate further since it strikes against the switch 16. Therefore, switch 16 remains in its original or second position during movement of lever 12 in the third position as shown in FIGS. 2 and 5. The lower surfaces 23 of the lent 17 simultaneously press the switch 15 as shown in FIG. 5. This third position is not stably balanced. When the lever 12 is released, the thrust of the spring 20 returns the device to the central or second position shown in FIG. 2 and the switch 15 snaps back to its only stably balanced position.

FIG. 6 shows a possible exemplificative electrical connection of the gearshift of this invention. The switches 15 and 16 used in the example are of the type with two switching contacts, and are connected, as shown, to interconnect two electric batteries 26 and 27 to an electric motor 28 to drive the car. The circuit also comprises a device 29 for controlling the speed of rotation of the motor. This device 29 can be of any known type, for example electronic, as is well known by the technician, and can be controlled, for example, by a pedal disposed in a position similar to that of the accelerator pedal of a normal car.

As can be seen in the wiring diagram (where the switches are in the positions corresponding to FIG. 2), the two batteries (for example 6V) are connected, by means of the switch 16, in parallel with each other. In

Explore Litigation Insights

Docket Alarm provides insights to develop a more informed litigation strategy and the peace of mind of knowing you're on top of things.

Real-Time Litigation Alerts



Keep your litigation team up-to-date with **real-time alerts** and advanced team management tools built for the enterprise, all while greatly reducing PACER spend.

Our comprehensive service means we can handle Federal, State, and Administrative courts across the country.

Advanced Docket Research



With over 230 million records, Docket Alarm's cloud-native docket research platform finds what other services can't. Coverage includes Federal, State, plus PTAB, TTAB, ITC and NLRB decisions, all in one place.

Identify arguments that have been successful in the past with full text, pinpoint searching. Link to case law cited within any court document via Fastcase.

Analytics At Your Fingertips



Learn what happened the last time a particular judge, opposing counsel or company faced cases similar to yours.

Advanced out-of-the-box PTAB and TTAB analytics are always at your fingertips.

API

Docket Alarm offers a powerful API (application programming interface) to developers that want to integrate case filings into their apps.

LAW FIRMS

Build custom dashboards for your attorneys and clients with live data direct from the court.

Automate many repetitive legal tasks like conflict checks, document management, and marketing.

FINANCIAL INSTITUTIONS

Litigation and bankruptcy checks for companies and debtors.

E-DISCOVERY AND LEGAL VENDORS

Sync your system to PACER to automate legal marketing.