



US005644114A

# United States Patent [19]

[11] Patent Number: **5,644,114**

Neaves

[45] Date of Patent: **Jul. 1, 1997**

[54] **PLURAL SWITCH ARRANGEMENT INCLUDING SHIFTER CAM FOR CHILDREN'S RIDE-ON VEHICLES**

5,237,302 8/1993 Harris ..... 337/4  
5,315,221 5/1994 Corey ..... 318/434

[75] Inventor: **Patrice M. Neaves**, Ft. Wayne, Ind.

*Primary Examiner*—J. R. Scott  
*Attorney, Agent, or Firm*—Kolisich, Hartwell, Dickinson, McCormack & Heuser

[73] Assignee: **Mattel, Inc.**, El Segundo, Calif.

### [57] ABSTRACT

[21] Appl. No.: **497,821**

A shifter design for a child's ride-on vehicle is described. The shifter allows for selection of various speeds and directions while precluding the selection of undesirable speeds and directions. Preferably the shifter includes a housing mounted on the body of the vehicle, a speed and direction switch mounted on the housing and an actuator on the housing for selectively contacting the switches. The switches are conventional rocker switches pivotable about a central axis to two settings. In the preferred embodiment, the actuator is pivotally mounted to the housing and a depending selection member with longitudinally-spaced annular structure pivots about an axis generally perpendicular to the pivot axes of the switches to contact the switches. In other embodiments, the actuator is slidably mounted to the housing. The rocker switches are provided with concave contact surfaces to ensure the desired speed and direction are selected.

[22] Filed: **Jul. 3, 1995**

[51] Int. Cl.<sup>6</sup> ..... **H01H 3/00; H01H 21/80**

[52] U.S. Cl. .... **200/6 R; 200/6 B; 200/18**

[58] Field of Search ..... 200/1 R, 5 R,  
200/6 R, 6 B, 17 R, 18, 61.85, 61.88, 339

### [56] References Cited

#### U.S. PATENT DOCUMENTS

3,657,493	4/1972	Horsley	.....	200/6 B
3,995,579	12/1976	Childre	.....	440/7
4,052,578	10/1977	Hoke	.....	200/574
4,088,852	5/1978	Van Doren	.....	200/18 X
4,132,128	1/1979	Roggenkamp	.....	74/527
4,639,646	1/1987	Harris et al.	.....	318/139
4,736,648	4/1988	Perego	.....	74/474
5,173,591	12/1992	Perego	.....	200/61.88

**11 Claims, 3 Drawing Sheets**

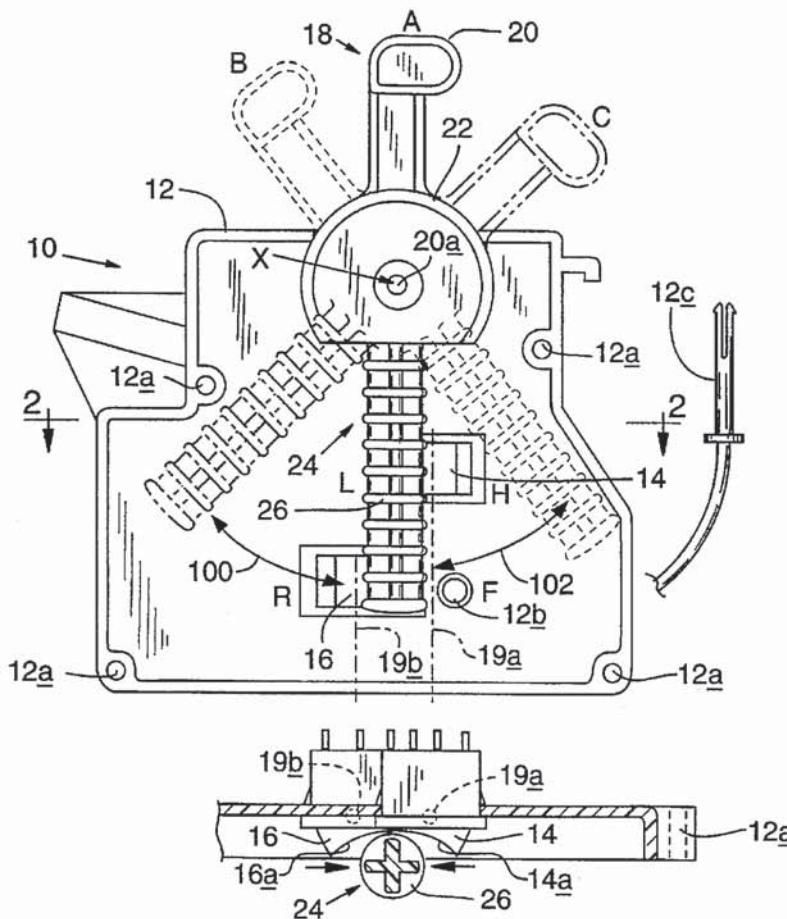

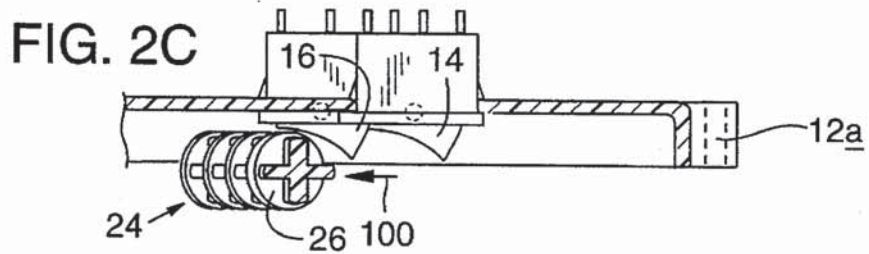
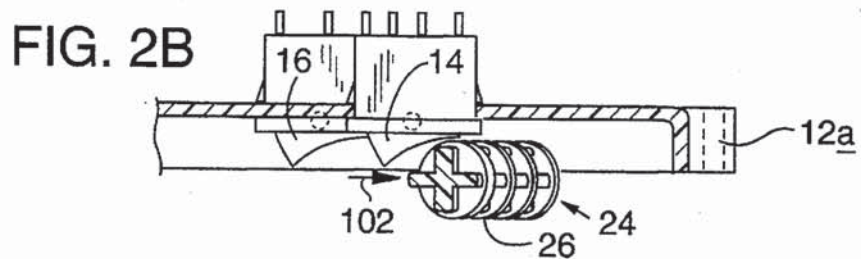
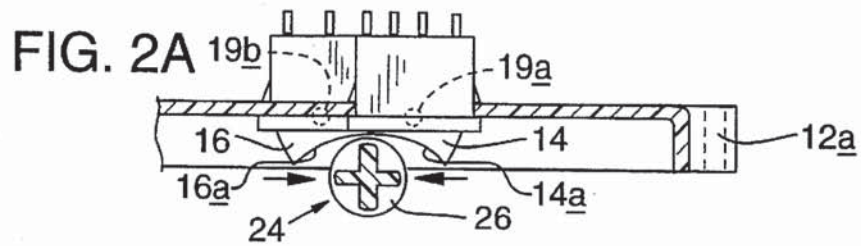
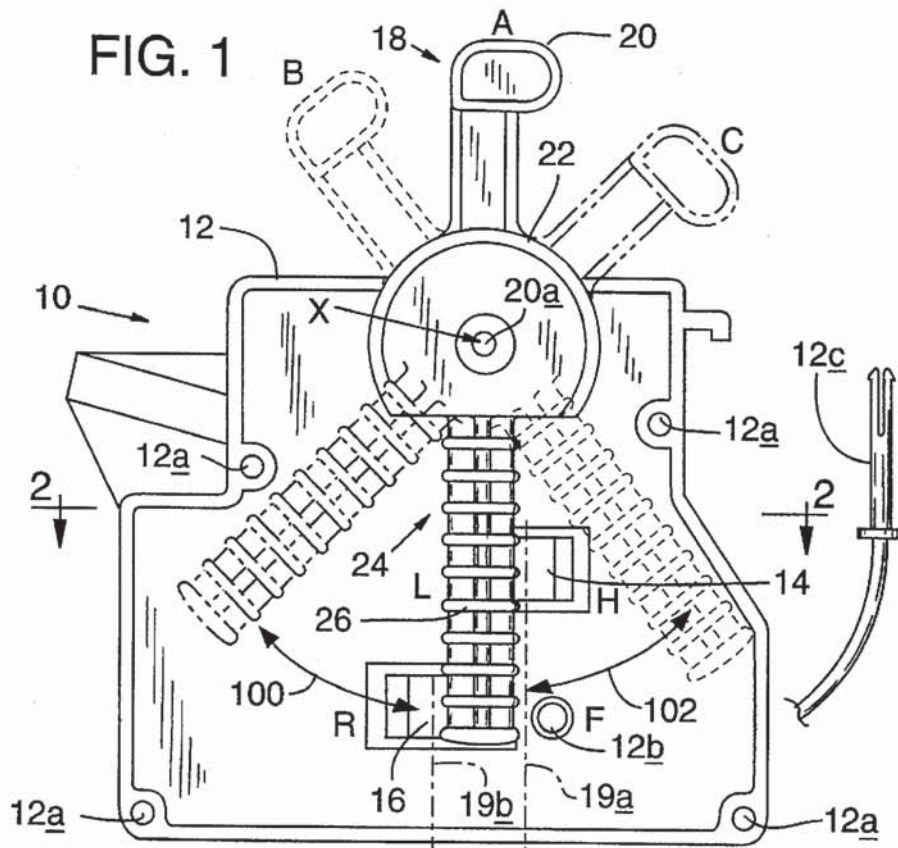

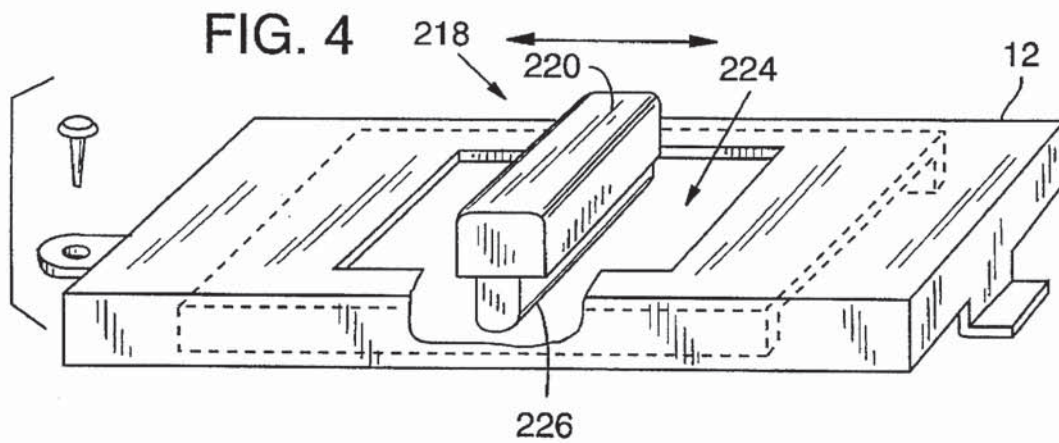
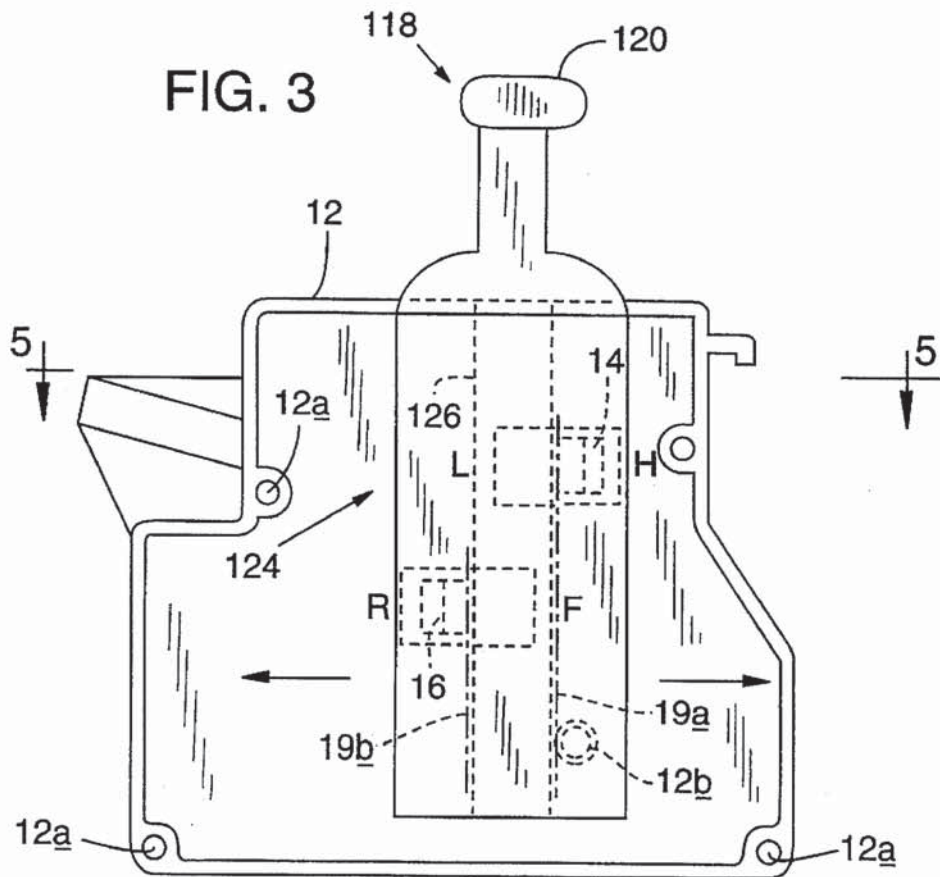

FIG. 5

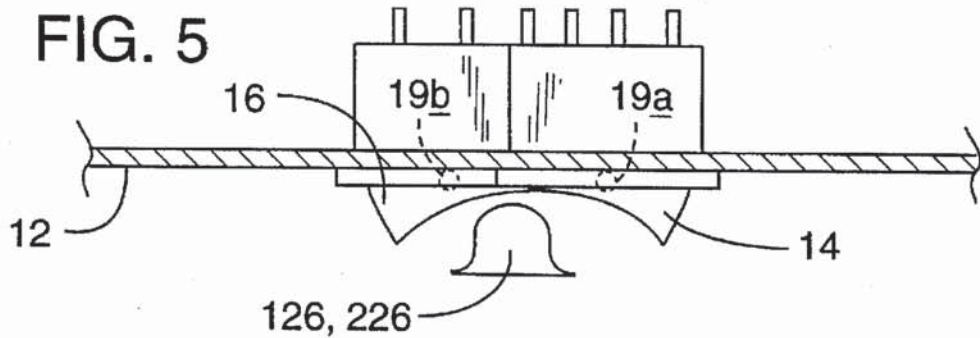
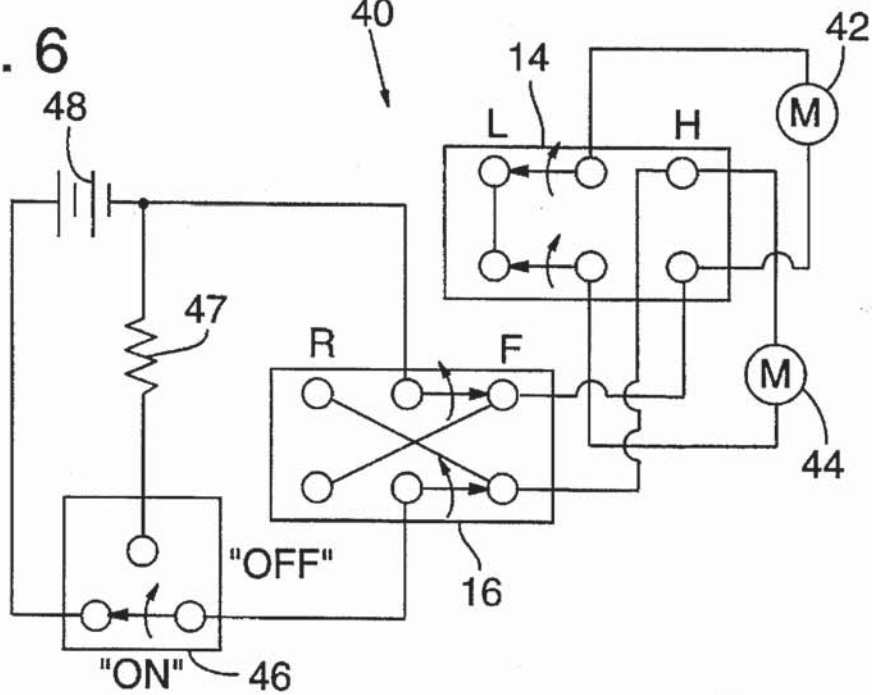

FIG. 6



**PLURAL SWITCH ARRANGEMENT  
INCLUDING SHIFTER CAM FOR  
CHILDREN'S RIDE-ON VEHICLES**

**BACKGROUND AND SUMMARY OF THE  
INVENTION**

The present invention relates generally to children's ride-on vehicles. More specifically, the invention concerns a simplified shifter design which allows a child to select between varying speeds and directions such as high speed forward and low speed forward and reverse. The invention mechanically precludes the selection of undesirable speeds and directions, such as high speed reverse.

In the last few years, ride-on vehicles having motors, intended for use by children have become popular toys. These toys come in many shapes and sizes depending on the age and size of a particular child. Typically, the ride-on vehicles will have a battery source connected to an electric motor which drives one or more of the vehicle's wheels according to the speed and direction selected by the child.

To operate the vehicle, a child will sit on or within the vehicle, and by pressing a pedal or moving a switch on a control panel, the vehicle's motor is energized by the battery source and the vehicle is driven by the child in much the same way an adult operates an automobile.

Most vehicles have more than one speed and several have more than one direction. In vehicles having more than one speed, there is usually a fast and a slow speed. In vehicles having more than one direction, the second direction is usually reverse.

It is well known that a high speed reverse mode is undesirable because a child cannot see where they are going. Conventional attempts have been made to eliminate this setting or reduce the chances of inadvertently selecting it. One such attempt is U.S. Pat. No. 5,173,591 to Perego which discloses a gear shift connected to two rotatable elements. The rotatable elements have a spring therebetween and are designed to selectively contact a speed and direction switch, which in turn select connections between an electric motor and a set of batteries to achieve multiple running modes. Perego precludes a high speed/reverse mode by allowing reverse to be selected only when the speed switch is in the low position and the force of a spring acting between the rotatable elements is overcome by a rider moving the shift. Thus, to enable only a low speed/reverse mode, Perego employs: two different types of switches (one having two fixed positions and one having only one fixed position), two rotatable elements, and a spring acting therebetween.

While it is desirable to preclude the high speed reverse mode, it is also desirable to reduce the number of elements and moving parts necessary to do so and to provide a design which is inexpensive to manufacture and easy to assemble. The design must be durable enough to withstand the often times destructive way that a child uses the vehicle. It is also desirable to provide a ride-on toy in which the high/forward setting can be disabled until the child learns how to correctly and safely operate the vehicle at slower speeds.

With the above problems in mind, a general object of this invention is to provide a child's ride-on vehicle which has a shifter design connected between a power source and a motor source which enables a child to select between desired speeds and directions and precludes the selection of undesired speeds and directions.

It is another object of this invention to provide a housing and shifter design which may be used in a child's ride-on

vehicle to enable a child to select between a high/forward, a low/forward and a low/reverse mode of operation while precluding the selection of a high/reverse mode.

Another object of the invention is to provide a shifter design which is inexpensive to manufacture and durable enough to withstand the use to which it may be put by a child.

The invention achieves these and other objects in the form of a simplified shifter which reduces the number of components necessary, utilizes the same type of switch for both the direction and speed control, and provides for a switch contact surface which complements the structure of a gear actuator or selector to ensure that the desired mode is selected.

The shifter design in the preferred embodiment of the invention features a housing or casing on which two rocker switches are housed: a high/low switch and a forward/reverse switch. The switches are connected between a battery source and plural motors and are adjacent one another. An actuator or shifter is pivotally mounted to the housing and moved in a plane parallel to the pivot axes of the switches. The actuator has a depending selection member with longitudinally-spaced annular structure for selectively contacting the switches upon movement of the shifter by the rider. The high/forward setting corresponds to a parallel connection between the plural motors and the low/forward and low/reverse settings correspond to a series connection between the plural motors. The switches are positioned to preclude a high/reverse setting. Hence, a child riding on the toy in which the shifter is configured, may select between only three distinct modes of operation: high/forward, low/forward and low/reverse. Further, a removable stop element is provided and may be used by an adult to prevent the child from selecting the high/forward mode, until the child learns to control the vehicle at lower speeds.

In an alternative embodiment of the invention, the shifter features an actuator slidably mounted to the housing adjacent the speed and direction switches. The actuator slides in a path generally parallel to the pivot axes of the speed and direction switches and includes an elongate selection member, transverse the slide path of the actuator, for selectively contacting the switches.

These and additional objects and advantages of the present invention will be more readily understood after a consideration of the drawings and the detailed description of the preferred and alternative embodiments.

**BRIEF DESCRIPTION OF THE DRAWINGS**

FIG. 1 is a side-plan view of the shifter according to the preferred embodiment, with a portion of the housing removed to show detail.

FIGS. 2A, 2B, and 2C, are top-sectional views of the shifter, taken generally along line 2—2 in FIG. 1 showing three different positions to which the shifter may be set.

FIG. 3 is a side-plan view of an alternative embodiment of the present invention.

FIG. 4 is an isometric view of another alternative embodiment of the shifter with a portion broken away to show detail.

FIG. 5 is a top-sectional view of the alternative embodiment similar to the view in FIG. 2A, taken generally along line 5—5 in FIG. 3.

FIG. 6 is a schematic diagram of the electrical system of the present invention.

**DETAILED DESCRIPTION OF THE  
PREFERRED EMBODIMENT**

FIG. 1 shows a housing and shifter assembly unit according to the preferred embodiment generally at 10 where it

# Explore Litigation Insights

Docket Alarm provides insights to develop a more informed litigation strategy and the peace of mind of knowing you're on top of things.

## Real-Time Litigation Alerts



Keep your litigation team up-to-date with **real-time alerts** and advanced team management tools built for the enterprise, all while greatly reducing PACER spend.

Our comprehensive service means we can handle Federal, State, and Administrative courts across the country.

## Advanced Docket Research



With over 230 million records, Docket Alarm's cloud-native docket research platform finds what other services can't. Coverage includes Federal, State, plus PTAB, TTAB, ITC and NLRB decisions, all in one place.

Identify arguments that have been successful in the past with full text, pinpoint searching. Link to case law cited within any court document via Fastcase.

## Analytics At Your Fingertips



Learn what happened the last time a particular judge, opposing counsel or company faced cases similar to yours.

Advanced out-of-the-box PTAB and TTAB analytics are always at your fingertips.

## API

Docket Alarm offers a powerful API (application programming interface) to developers that want to integrate case filings into their apps.

## LAW FIRMS

Build custom dashboards for your attorneys and clients with live data direct from the court.

Automate many repetitive legal tasks like conflict checks, document management, and marketing.

## FINANCIAL INSTITUTIONS

Litigation and bankruptcy checks for companies and debtors.

## E-DISCOVERY AND LEGAL VENDORS

Sync your system to PACER to automate legal marketing.