



- [54] **SPEED CONTROL SYSTEM FOR A REMOTE-CONTROL VEHICLE**
- [75] Inventor: **David J. Ribbe**, Cincinnati, Ohio
- [73] Assignee: **Hasbro, Inc.**, Pawtucket, R.I.
- [21] Appl. No.: **08/794,438**
- [22] Filed: **Feb. 5, 1997**
- [51] **Int. Cl.⁶** **H02P 7/29**
- [52] **U.S. Cl.** **318/16; 318/293; 388/829**
- [58] **Field of Search** **318/16, 293, 139; 388/825, 828, 829**

5,495,155	2/1996	Juzswik et al.	318/293
5,571,999	11/1996	Harris	200/565
5,577,154	11/1996	Orton	388/811

OTHER PUBLICATIONS

TX5/RX5 Remote Controller with Nine Functions, *Product Description*(Nov. 1994).

Primary Examiner—Bentsu Ro
Attorney, Agent, or Firm—Marshall, O’Toole, Gerstein, Murray & Borun

[57] **ABSTRACT**

A remote-control vehicle includes a controller that produces a pulse-width modulated (PWM) motor control signal and a forward/reverse motor control signal in response to a transmitted digital signal specifying one of a multiplicity of speed control states, each of which has a direction and a PWM duty cycle associated therewith. A MOSFET switch turns on and off in response to the PWM signal to control the flow of current between a battery and a motor to thereby control the speed of the motor. A relay, coupled between the battery and the motor, switches in response to the forward/reverse signal to change the direction of current flow through the motor to thereby control the direction of the motor.

23 Claims, 3 Drawing Sheets

[56] **References Cited**

U.S. PATENT DOCUMENTS

4,349,986	9/1982	Tsukuda	46/254
4,749,927	6/1988	Rodal et al.	318/599
4,999,556	3/1991	Masters	318/599
5,043,640	8/1991	Orton	318/16
5,065,078	11/1991	Nao et al.	318/16
5,103,146	4/1992	Hoffman	318/16
5,136,452	8/1992	Orton	361/33
5,150,027	9/1992	Suzuki	318/581
5,216,337	6/1993	Orton et al.	318/16
5,218,276	6/1993	Yeom et al.	318/16

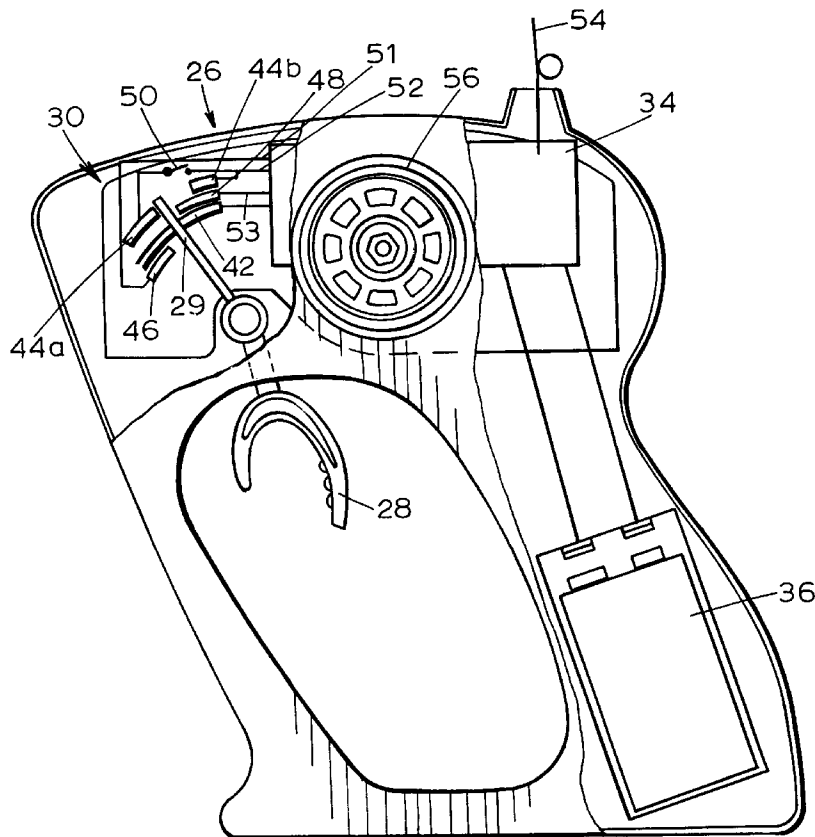

FIG. 1

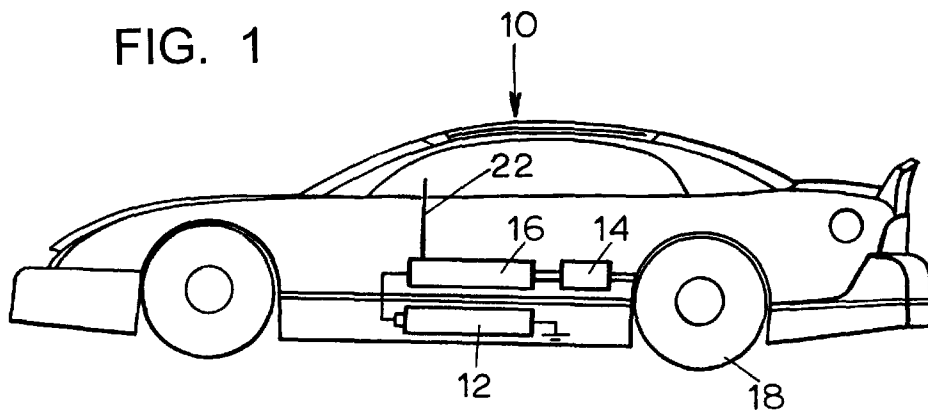
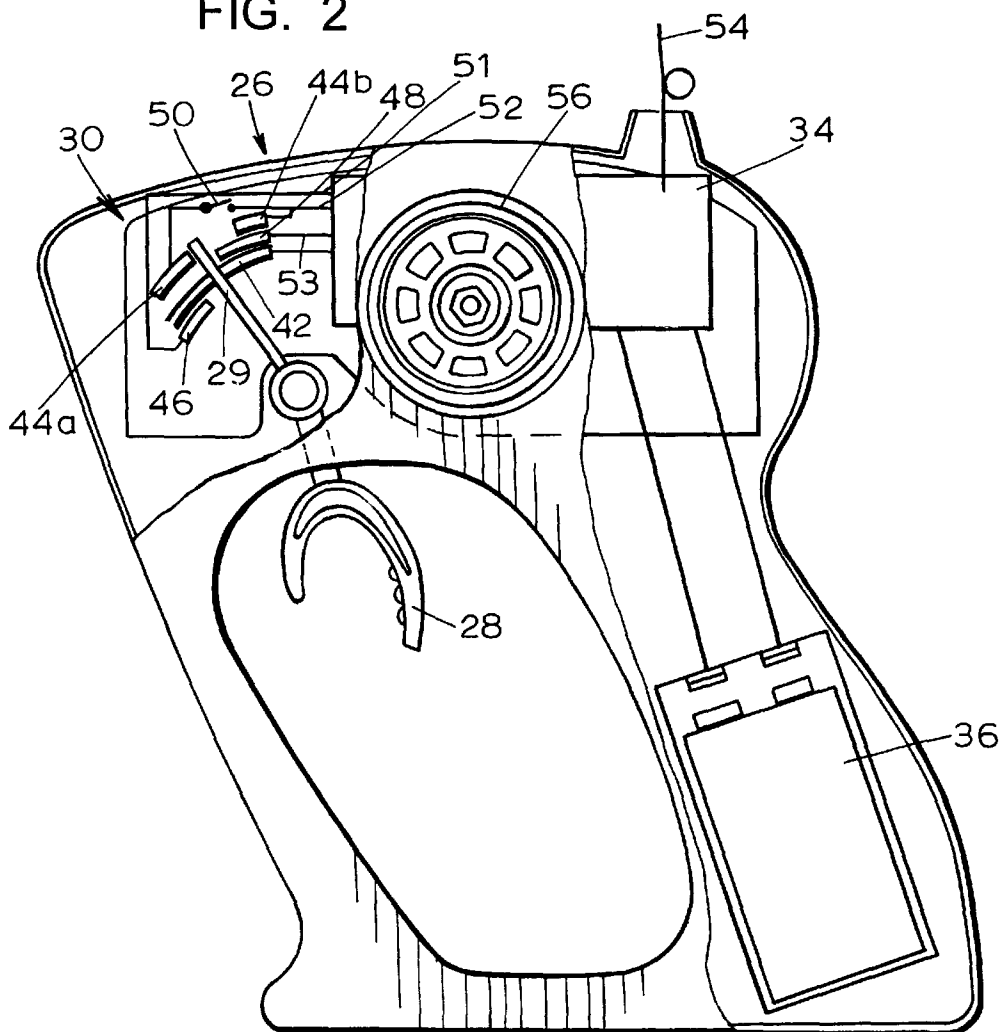

FIG. 2



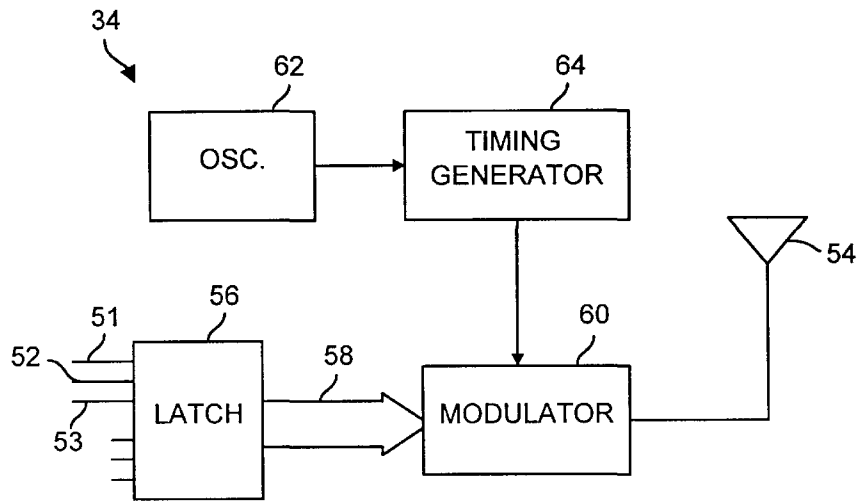

FIG. 3

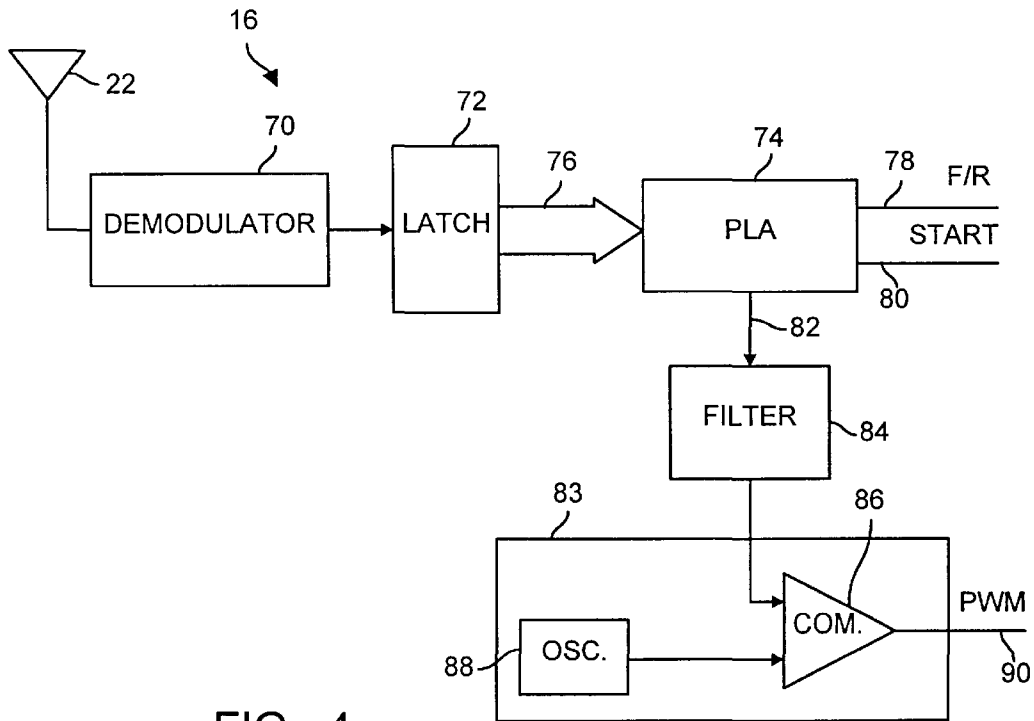

FIG. 4

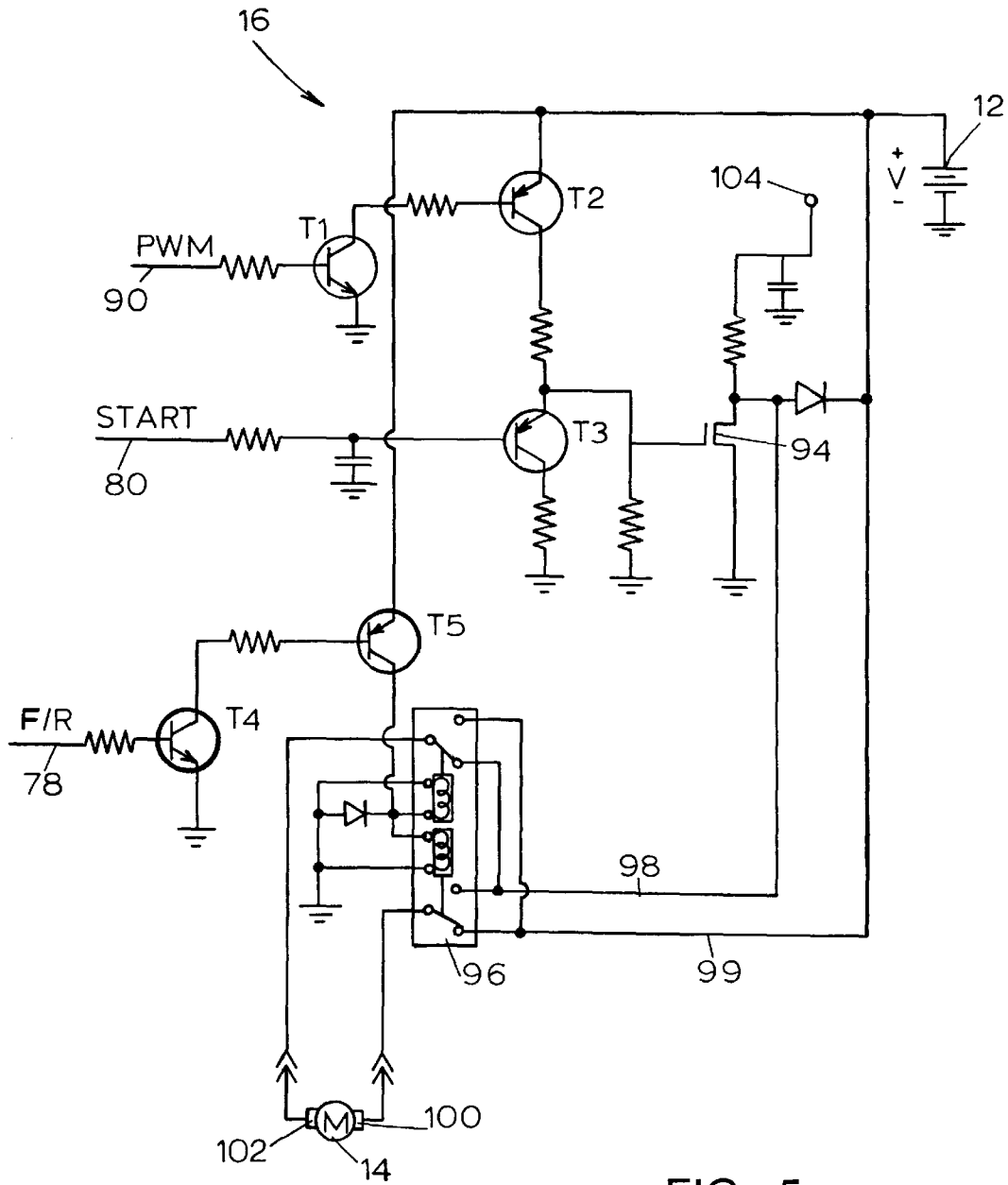

FIG. 5

SPEED CONTROL SYSTEM FOR A REMOTE-CONTROL VEHICLE

BACKGROUND OF THE INVENTION

The present invention relates generally to motor speed 5
controllers and, more particularly, to speed controllers for
remote-control toy vehicles.

DESCRIPTION OF RELATED ART

It is known to use pulse-width modulated (PWM) signals 10
to control the flow of current through a motor in, for
example, a remote-control vehicle, to thereby control the
speed of the motor. For example, Nao et al., U.S. Pat. No.
5,065,078; Orton, U.S. Pat. No. 5,577,154; and Suzuki, U.S.
Pat. No. 5,150,027 each discloses a remote-control device 15
using a PWM signal to control the power provided to a
motor. In these devices, the duty cycle of the PWM signal is
increased to increase the speed of the motor and is decreased
to decrease the speed of the motor. Typically, however,
remote-control vehicles receive an analog control signal that 20
must be demodulated and used to produce a PWM control
signal of varying duty cycle. For example, the device of Nao
et al. (U.S. Pat. No. 5,065,078) uses a stretched analog PWM
signal developed from a received analog PWM control
signal to generate a PWM motor control signal. Likewise, 25
Suzuki (U.S. Pat. No. 5,150,027) develops an analog PWM
signal from a received control signal, compares the PWM
signal with a pulse signal generated by a one-shot circuit,
and detects the difference between the widths of the two
signals to determine the pulse width of a PWM motor 30
control signal. Such analog decoding circuits require numer-
ous components, which adds to the weight of the remote-
control vehicle and reduces the life of a battery powering the
vehicle.

Remote-control vehicles have also used elaborate circuits 35
to effect forward and reverse motor functions. For example,
Nao et al. (U.S. Pat. No. 5,065,078) develops a stretched
analog PWM signal from a received analog PWM control
signal, compares the stretched PWM signal with a pulse
signal generated by a one-shot circuit, and detects the 40
difference between the trailing edges of the two signals to
determine the direction of a motor. Other prior art motor
control circuits, such as those disclosed in Tsukuda, U.S.
Pat. No. 4,349,986, and Juzswik et al., U.S. Pat. No.
5,495,155, use an H-bridge circuit, having semiconductor 45
devices in the legs thereof, to drive a motor in both the
forward and reverse directions. Typically, the semiconductor
devices of such H-bridge circuits are operated to turn one leg
of the bridge circuit off while turning the other leg on which
changes the direction of current flow through the motor and, 50
thereby, reverses the direction of the motor. However,
H-bridge circuits typically require a relatively high amount
of power to operate and develop voltage drops across the
numerous semi-conductor devices connected in series with
the motor, which reduces the amount of power supplied to 55
the motor. These circuits also tend to increase the depletion
of the battery which reduces the use time of the battery.

SUMMARY OF THE INVENTION

The present invention relates to a remote-control vehicle 60
that provides a variable duty cycle PWM signal to a motor
to vary the speed of the motor while simultaneously con-
trolling the direction of the motor using simple, lightweight,
and cost effective switching networks that do not have large
voltage drops associated therewith.

In particular, a remote-control vehicle according to the
present invention receives a digital signal specifying one of

a multiplicity of speed control states, each of which has a
direction and a PWM duty cycle associated therewith. A
speed controller located on the vehicle decodes the received
digital signal to identify the specified speed control state and
produces a PWM signal and a forward/reverse signal in
response thereto. The PWM signal, which controls the speed
of a motor, is coupled to a switch, preferably comprising a
semiconductor switch such as metal oxide semiconductor
field effect transistor (MOSFET), and controls the flow of
current between a power source, such as a battery, and the
motor. The duty cycle of the PWM signal is varied from
speed control state to speed control state to vary the speed
of the motor. The forward/reverse signal controls the opera-
tion of a further switch coupled between the motor and the
battery to change the direction of current flow through the
motor. Preferably the further switch comprises a dual input,
quadruple output relay, such as a double pole, double throw
relay. In one embodiment, the relay has two sets of two
outputs connected together such that each of the connected
sets of outputs is coupled through one of the relay inputs to
one of a set of motor terminals.

According to another aspect of the present invention, a
speed control system for use in a remote-control vehicle
includes a receiver that receives a digital control signal and
produces a digital state signal specifying one of a multiplicity
of speed control states and a speed controller responsive
to the digital state signal that develops a forward/reverse
signal and a PWM speed signal based on the specified one
of the multiplicity of speed control states. A first switch is
coupled between a power source and a motor and is respon-
sive to the PWM signal for delivering a power signal from
the power source to the motor. A second switch is coupled
between the power source and the motor and is responsive
to the forward/reverse signal to control the direction of the
motor. Preferably, the receiver produces a digital state signal
specifying one of at least six speed control states, three of
which are forward states and two of which are reverse states.

The speed control system of the present invention may
include circuitry for producing a ramped duty cycle PWM
signal, varying between three or more different duty cycles
over a first period of time, in response to a change between
two non-consecutive speed control states in a second period
of time that is less than the first period of time. The speed
control system may also include a switch that prevents the
use of one of the speed control states when in a first position
and that allows the use of the one of the speed control states
when in a second position.

According to another aspect of the present invention, a
remote-control vehicle includes a transmitter module having
a speed position sensing device that detects one of a multi-
plicity of speed positions and a digital signal transmitter
coupled to the speed position sensing device that produces
a digital control signal indicating one of a multiplicity of
speed control states corresponding to the detected one of the
multiplicity of speed positions. The remote-control vehicle
also includes a vehicle having a receiver that receives the
digital control signal and produces a digital state signal
specifying the one of the multiplicity of speed control states.
A speed controller on the vehicle develops a forward/reverse
signal and a PWM speed signal based on the one of the
multiplicity of speed control states specified by the digital
state signal. A first switch is responsive to the PWM signal
for delivering a power signal to a motor on the vehicle and
a second switch is coupled to the motor and is responsive to
the forward/reverse signal to control the direction of the
motor.

BRIEF DESCRIPTION OF THE DRAWINGS

FIG. 1 is a side view of a toy vehicle having a speed
control system according to the present invention;

Explore Litigation Insights

Docket Alarm provides insights to develop a more informed litigation strategy and the peace of mind of knowing you're on top of things.

Real-Time Litigation Alerts



Keep your litigation team up-to-date with **real-time alerts** and advanced team management tools built for the enterprise, all while greatly reducing PACER spend.

Our comprehensive service means we can handle Federal, State, and Administrative courts across the country.

Advanced Docket Research



With over 230 million records, Docket Alarm's cloud-native docket research platform finds what other services can't. Coverage includes Federal, State, plus PTAB, TTAB, ITC and NLRB decisions, all in one place.

Identify arguments that have been successful in the past with full text, pinpoint searching. Link to case law cited within any court document via Fastcase.

Analytics At Your Fingertips



Learn what happened the last time a particular judge, opposing counsel or company faced cases similar to yours.

Advanced out-of-the-box PTAB and TTAB analytics are always at your fingertips.

API

Docket Alarm offers a powerful API (application programming interface) to developers that want to integrate case filings into their apps.

LAW FIRMS

Build custom dashboards for your attorneys and clients with live data direct from the court.

Automate many repetitive legal tasks like conflict checks, document management, and marketing.

FINANCIAL INSTITUTIONS

Litigation and bankruptcy checks for companies and debtors.

E-DISCOVERY AND LEGAL VENDORS

Sync your system to PACER to automate legal marketing.