

3138 *Encyclopedia of*  
**ELECTRONIC  
CIRCUITS**

*Volume 2*

**Rudolf F. Graf**

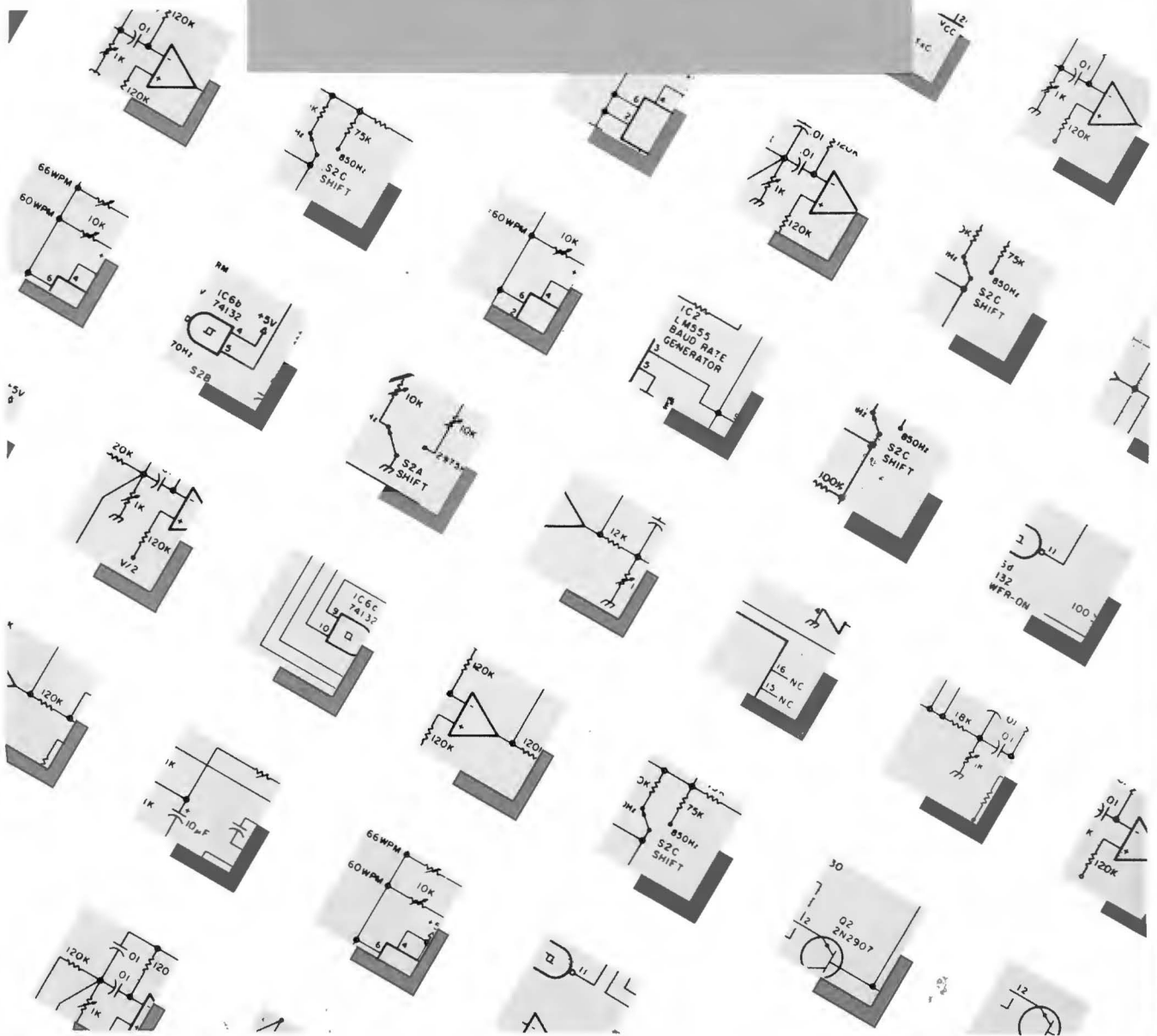

Dynacraft BSC, Inc.  
**Exhibit 1008**  
Dynacraft v. Mattel  
IPR2018-00039

*Encyclopedia of*  
**ELECTRONIC  
CIRCUITS**

*Volume 2*

**Rudolf F. Graf**

**TAB** TAB BOOKS

FIRST EDITION  
SEVENTH PRINTING

© 1988 by **Rudolf F. Graf**.  
Published by TAB Books.  
TAB Books is a division of McGraw-Hill, Inc.

Printed in the United States of America. All rights reserved. The publisher takes no responsibility for the use of any of the materials or methods described in this book, nor for the products thereof.

**Library of Congress Cataloging-in-Publication Data**

(Revised for v. 2)

Graf, Rudolf F.  
Encyclopedia of electronics circuits—Volume 2.

Bibliography: v. 1, p.  
Includes indexes.

1. Electronic circuits. I. Title.

TK7867.G66 1985 621.3815'3 84-26772

ISBN 0-8306-0938-5 (v. 1)

ISBN 0-8306-1938-0 (pbk. : v. 1)

ISBN 0-8306-9138-3 (v. 2)

ISBN 0-8306-3138-0 (pbk. : v. 2)

TAB Books offers software for sale. For information and a catalog, please contact  
TAB Software Department, Blue Ridge Summit, PA 17294-0850.

### PWM MOTOR SPEED CONTROL

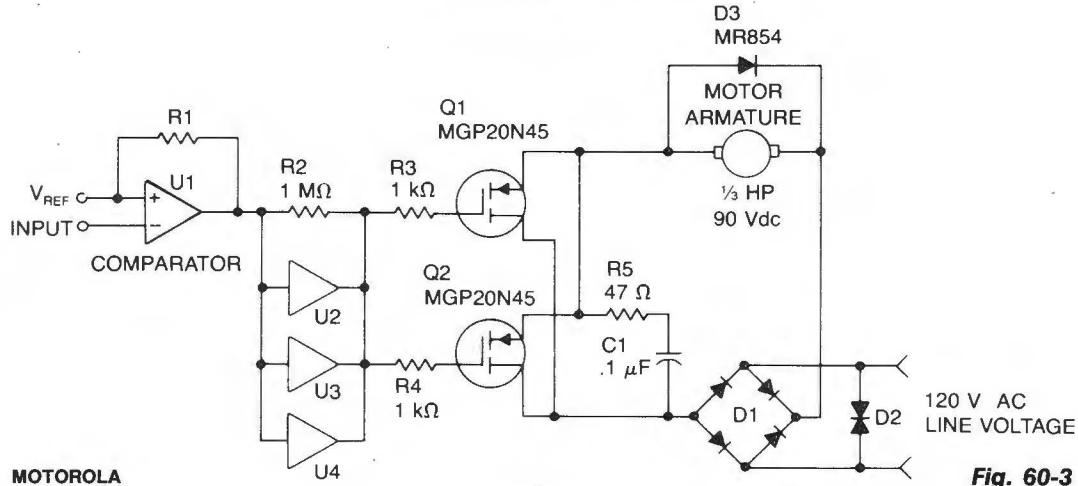

Fig. 60-3

#### Circuit Notes

Speed control is accomplished by pulse width modulating the gates of two MGP20N45 TMOS devices. Therefore, motor speed is proportional to the pulse width of the incoming digital signal, which can be generated by a microprocessor or digital logic.

The incoming signal is applied to comparator U1, then to paralleled inverters U2, U3, and U4 that drive the two TMOS devices, which, in turn, control power applied to the motor armature. Bridge rectifier D1 supplies fullwave power that is filtered by R5 and C1. Free-wheeling diode D3 (MR854) prevents high voltage across Q1 and Q2. A back-to-back zener diode, D2, protects against transients and high voltage surges.

### STEPPING MOTOR DRIVER

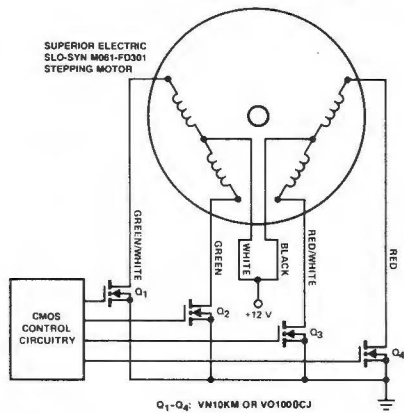

SILCONIX, INC.

Fig. 60-4

#### Circuit Notes

Stepping motors find wide use in disk drives and machine control. MOSPOWER transistors are ideal motor drivers because of their freedom from second breakdown. Note that snubbing networks are not used because load line shaping is not necessary with MOSPOWER and the inductance of the motor is fairly low so that the inductive spike is small. The MOSFET gates are tied directly to the outputs of the CMOS control circuitry. The logic is arranged to sequence the motor in accordance with the needs of the application.