



US007950978B2

(12) **United States Patent**
Norman et al.

(10) **Patent No.:** **US 7,950,978 B2**
(45) **Date of Patent:** ***May 31, 2011**

(54) **SYSTEM, APPARATUS AND METHOD FOR PROVIDING CONTROL OF A TOY VEHICLE**

(56) **References Cited**

(75) Inventors: **David A. Norman**, Greenville, TX (US);
Robert H. Mimlitch, III, Rowlett, TX (US); **Richard D. Torrance**, Greenville, TX (US)

(73) Assignee: **Innovation First, Inc.**, Greenville, TX (US)

(*) Notice: Subject to any disclaimer, the term of this patent is extended or adjusted under 35 U.S.C. 154(b) by 1135 days.

This patent is subject to a terminal disclaimer.

U.S. PATENT DOCUMENTS

3,732,751	A	5/1973	Berman et al.	
4,334,221	A	6/1982	Rosenbagen et al.	
4,336,858	A	6/1982	Loyzim	
4,341,982	A	7/1982	Lahti et al.	
5,056,613	A *	10/1991	Porter et al.	180/178
5,172,665	A	12/1992	Kuroda	
5,349,276	A	9/1994	Mezzatesta, Jr. et al.	
5,453,672	A	9/1995	Avitan	
5,762,532	A *	6/1998	Ishizuka et al.	446/457
5,951,362	A	9/1999	Siu	
5,994,853	A	11/1999	Ribbe	
6,287,167	B1 *	9/2001	Kondo	446/454
6,468,127	B1	10/2002	Lee	
6,591,178	B2	7/2003	Krueger et al.	
7,222,684	B2 *	5/2007	Norman et al.	180/65.1

* cited by examiner

(21) Appl. No.: **11/677,529**

Primary Examiner — Dmitry Suhol

(22) Filed: **Feb. 21, 2007**

Assistant Examiner — Alex F. R. P. Rada, II

(74) *Attorney, Agent, or Firm* — Fish & Richardson P.C.

(65) **Prior Publication Data**

US 2007/0135017 A1 Jun. 14, 2007

Related U.S. Application Data

(63) Continuation of application No. 10/076,795, filed on Feb. 12, 2002, now Pat. No. 7,222,684.

(60) Provisional application No. 60/268,447, filed on Feb. 12, 2001.

(51) **Int. Cl.**

A63H 30/00 (2006.01)

B60T 7/16 (2006.01)

(52) **U.S. Cl.** **446/454**; 446/456; 446/484; 180/167; 180/65.1

(58) **Field of Classification Search** 180/65.1, 180/167, 170, 174; 446/454-456; **A63H 30/00**

See application file for complete search history.

(57) **ABSTRACT**

A system, apparatus, and method for providing a soft-start for a toy vehicle configured to be operated by a person. The method includes receiving a throttle signal operable to induce motion via a motor operating as a drive mechanism of the toy vehicle. A transition signal may be generated based on the throttle signal. The transition signal may be applied to effect operation of the motor. The transition signal may be a pulse width modulated signal having a duty cycle between 20 and 100 percent to provide for an acceleration that avoids the problems of conventional control systems. The transition signal may be ramped in a linear or non-linear fashion. The system may couple the soft-start control circuit between a ground terminal of a battery of the toy vehicle and motor(s), thereby allowing the soft-start control circuit to operate on a low voltage (i.e., not the high voltage of the battery).

24 Claims, 13 Drawing Sheets

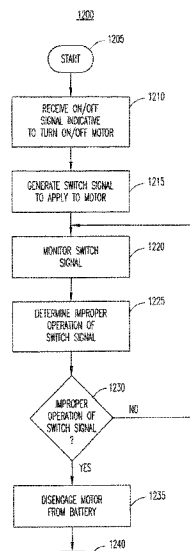

Dynacraft BSC, Inc.
Exhibit 1015
Dynacraft v. Mattel
IPR2018-00038

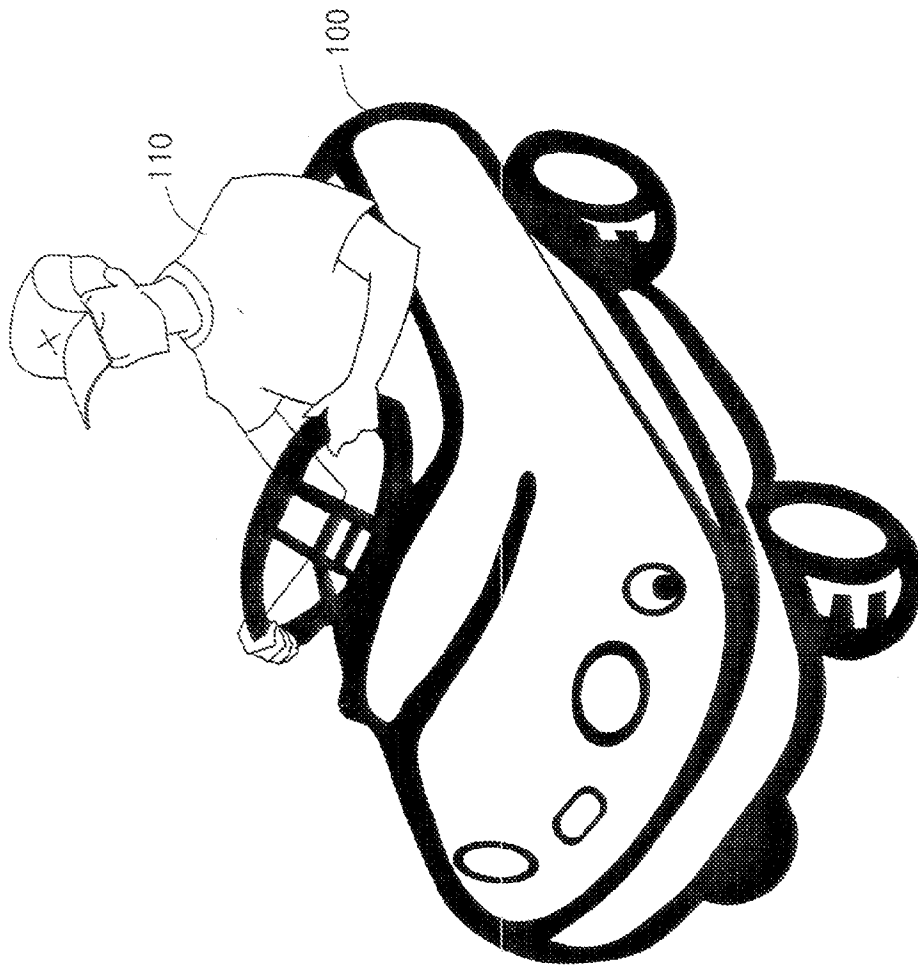

FIG. 1

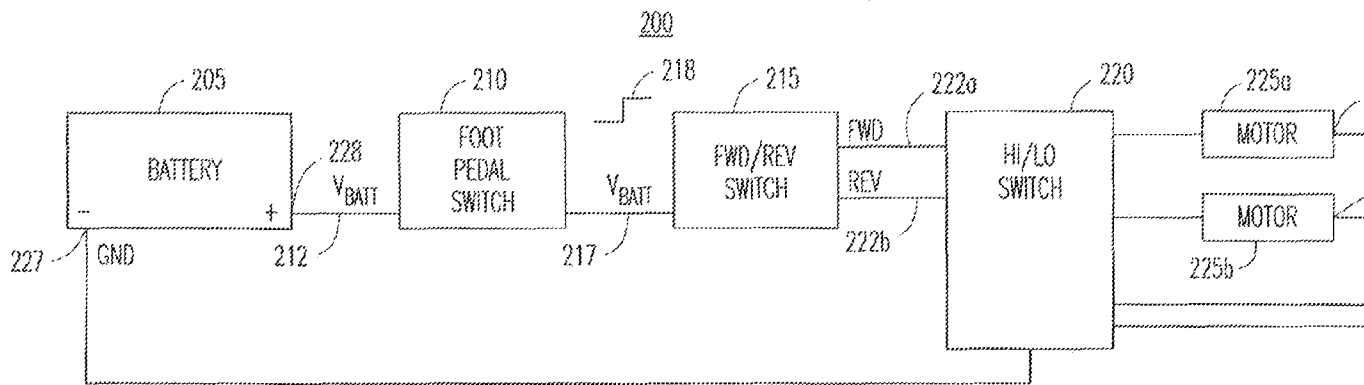

FIG. 2
(PRIOR ART)

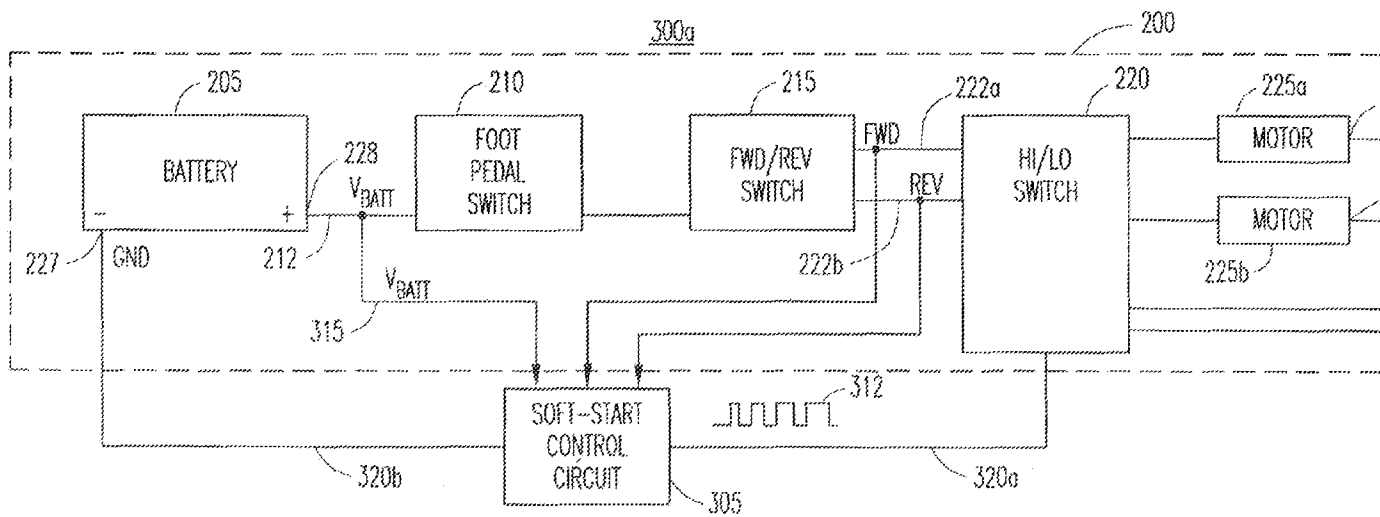

FIG. 3

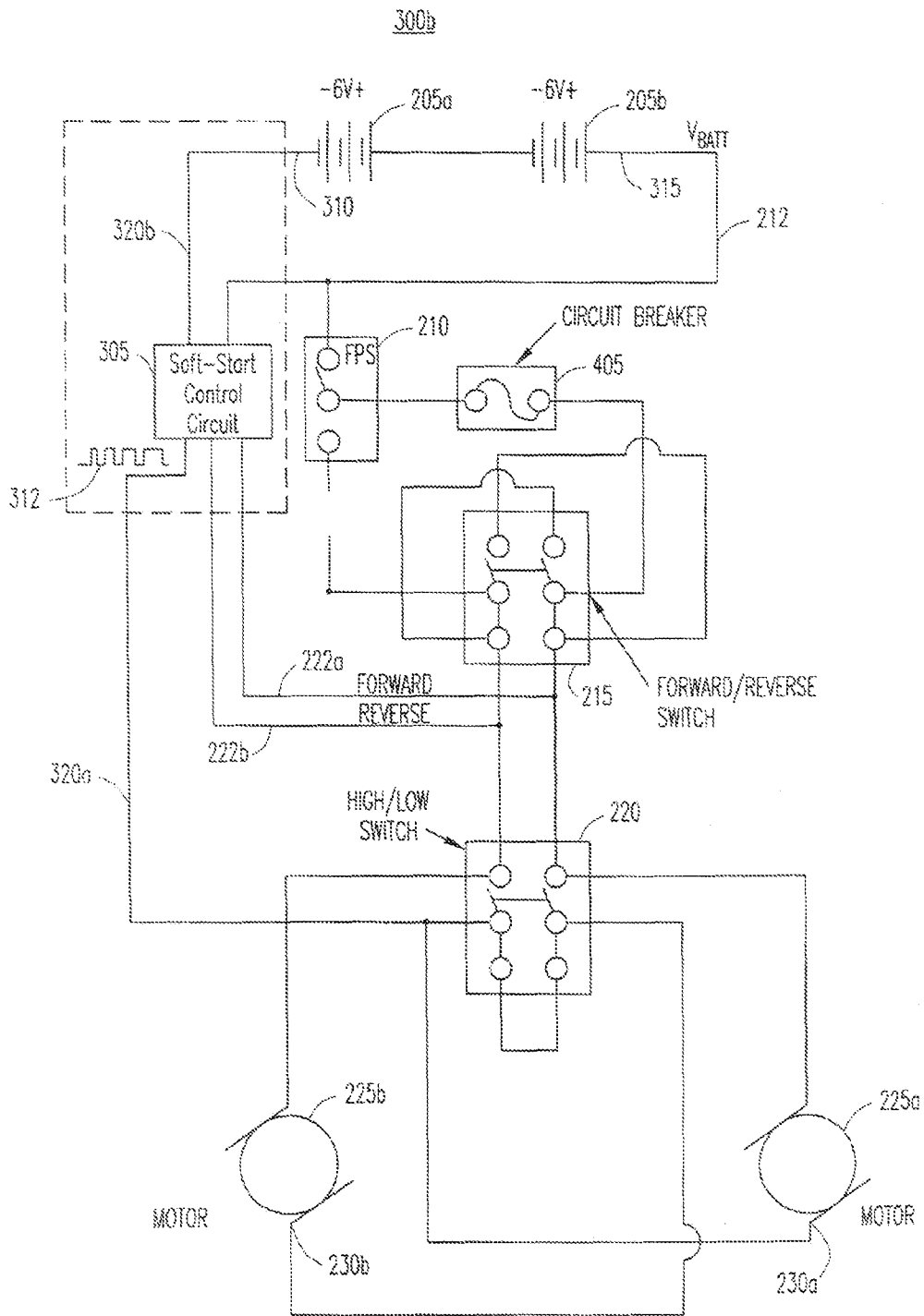

FIG. 4

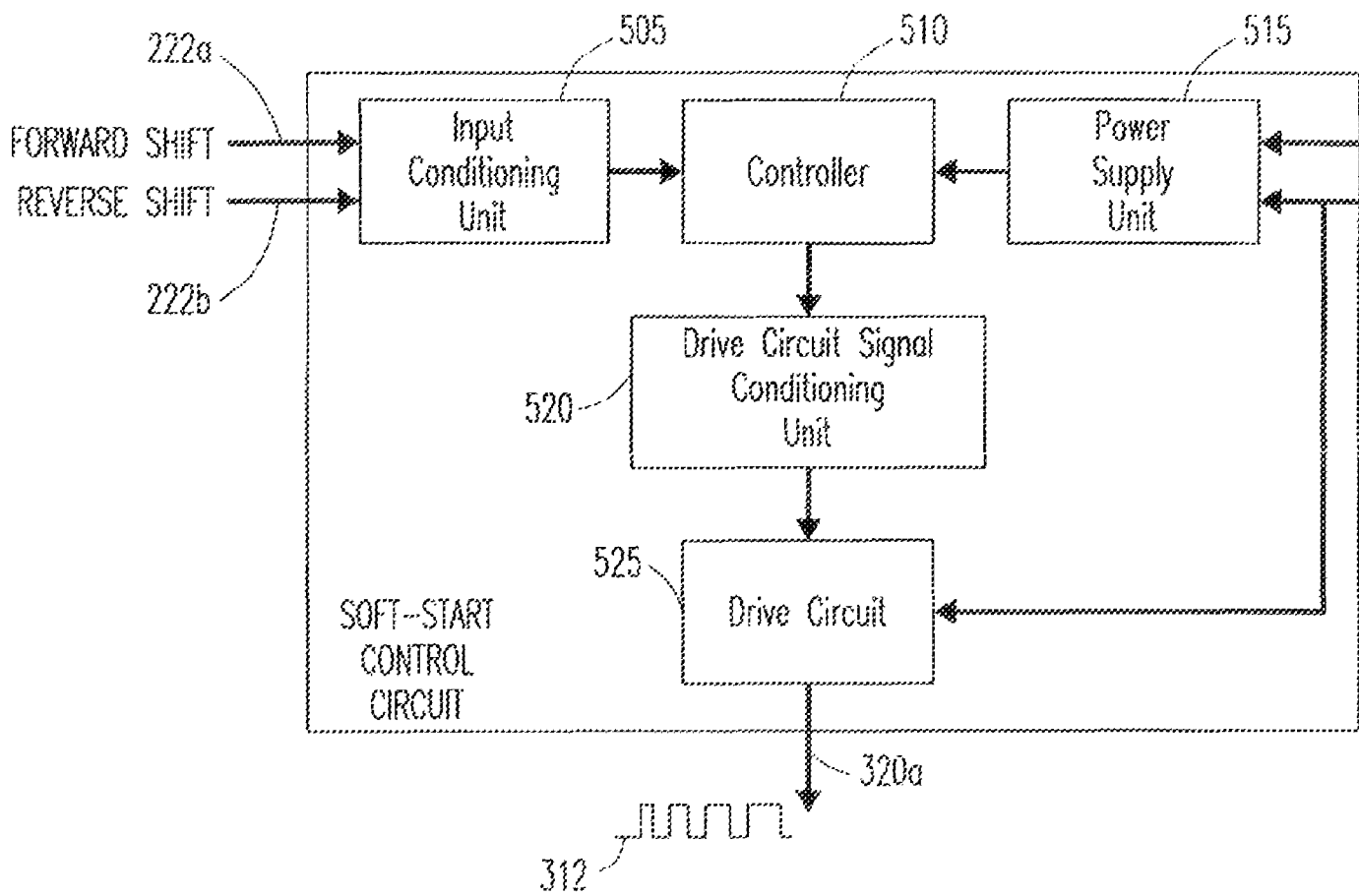

FIG. 5

Explore Litigation Insights

Docket Alarm provides insights to develop a more informed litigation strategy and the peace of mind of knowing you're on top of things.

Real-Time Litigation Alerts



Keep your litigation team up-to-date with **real-time alerts** and advanced team management tools built for the enterprise, all while greatly reducing PACER spend.

Our comprehensive service means we can handle Federal, State, and Administrative courts across the country.

Advanced Docket Research



With over 230 million records, Docket Alarm's cloud-native docket research platform finds what other services can't. Coverage includes Federal, State, plus PTAB, TTAB, ITC and NLRB decisions, all in one place.

Identify arguments that have been successful in the past with full text, pinpoint searching. Link to case law cited within any court document via Fastcase.

Analytics At Your Fingertips



Learn what happened the last time a particular judge, opposing counsel or company faced cases similar to yours.

Advanced out-of-the-box PTAB and TTAB analytics are always at your fingertips.

API

Docket Alarm offers a powerful API (application programming interface) to developers that want to integrate case filings into their apps.

LAW FIRMS

Build custom dashboards for your attorneys and clients with live data direct from the court.

Automate many repetitive legal tasks like conflict checks, document management, and marketing.

FINANCIAL INSTITUTIONS

Litigation and bankruptcy checks for companies and debtors.

E-DISCOVERY AND LEGAL VENDORS

Sync your system to PACER to automate legal marketing.