



US006076025A

United States Patent [19]

Ueno et al.

[11] **Patent Number:** 6,076,025

[45] **Date of Patent:** Jun. 13, 2000

[54] **MOBILE ROBOT STEERING METHOD AND CONTROL DEVICE**

[75] Inventors: **Ichirou Ueno; Hironori Katou**, both of Saitama, Japan

[73] Assignee: **Honda Giken Kogyo K.K.**, Tokyo, Japan

[21] Appl. No.: **09/015,312**

[22] Filed: **Jan. 29, 1998**

[30] **Foreign Application Priority Data**

Jan. 29, 1997 [JP] Japan 9-029768

[51] **Int. Cl.⁷** **G06F 165/00**

[52] **U.S. Cl.** **701/23; 701/25; 701/26**

[58] **Field of Search** **701/23, 25, 26**

[56] **References Cited**

U.S. PATENT DOCUMENTS

4,939,650 7/1990 Nishikawa 364/424.02
5,081,585 1/1992 Kurami et al. 364/424.02

5,377,106 12/1994 Drunk et al. 364/424.02
5,548,511 8/1996 Bancroft 364/424.02
5,570,285 10/1996 Asaka et al. 364/424.02
5,925,080 6/1999 Shimbara et al. 701/23

Primary Examiner—Tan Nguyen

Assistant Examiner—Dalena Tran

Attorney, Agent, or Firm—Armstrong, Westerman, Hattori, McLeland & Naughton

[57] **ABSTRACT**

A robot is provided to run so that a trace of the robot efficiently covers a given area according to the detection of a boundary of the area. A spiral pattern running, wherein a radius of the spiral is gradually increased, is started at a desired location in the area and is paused upon the detection of a boundary wall by sensors. Then, a random pattern running, which includes turning to depart from the wall and running forward, is conducted. After the turning has been repeated a predetermined number of times through simulations, the spiral pattern running is resumed at a location spaced from the last turning spot by a predetermined distance or a predetermined length of running time.

19 Claims, 13 Drawing Sheets

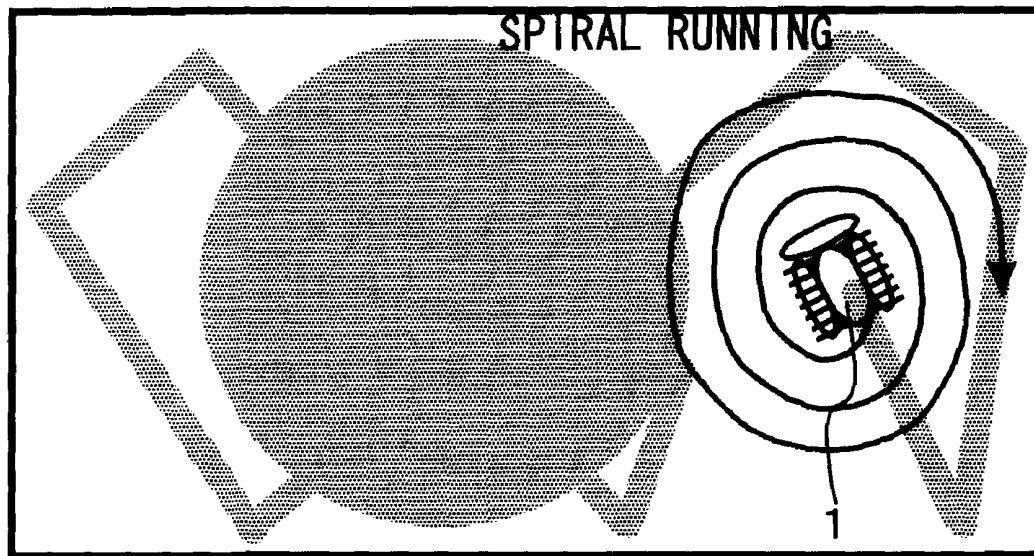

FIG. 1

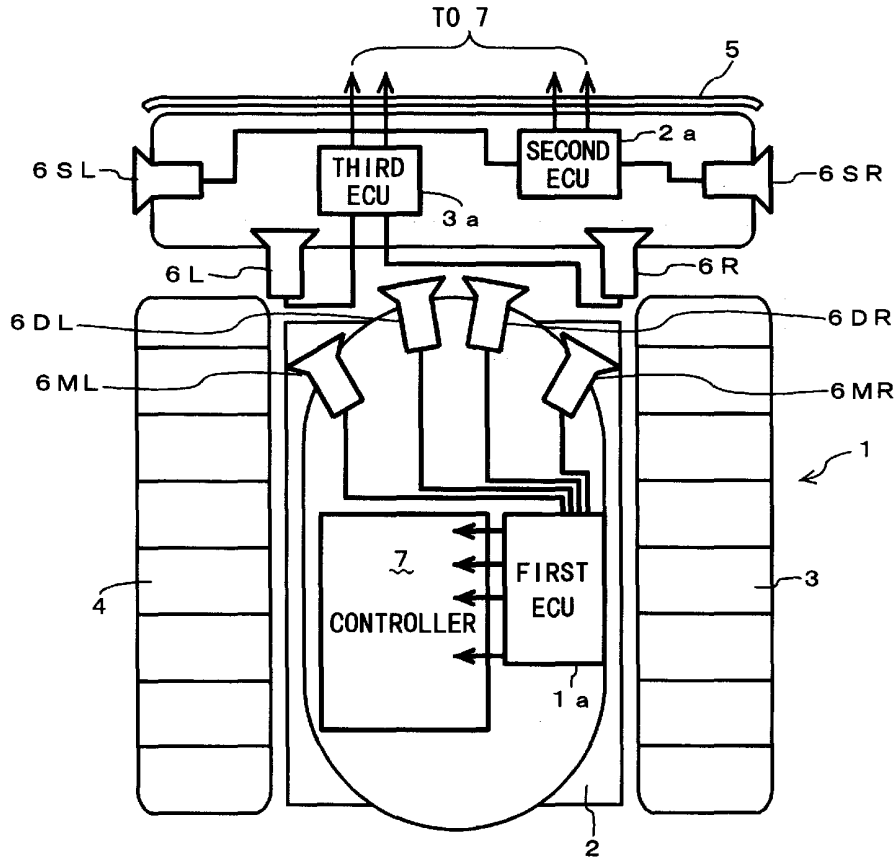

FIG. 2

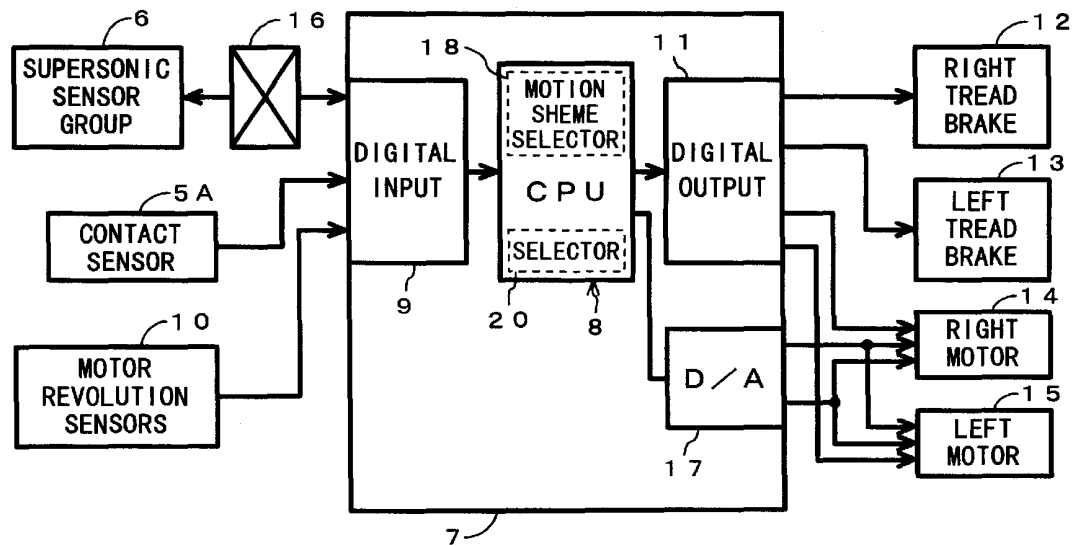

FIG. 3

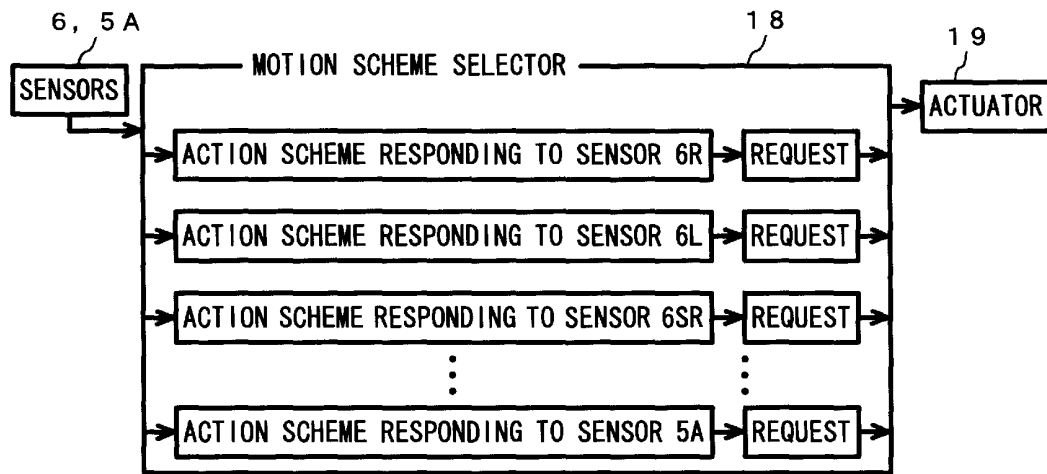

FIG. 4

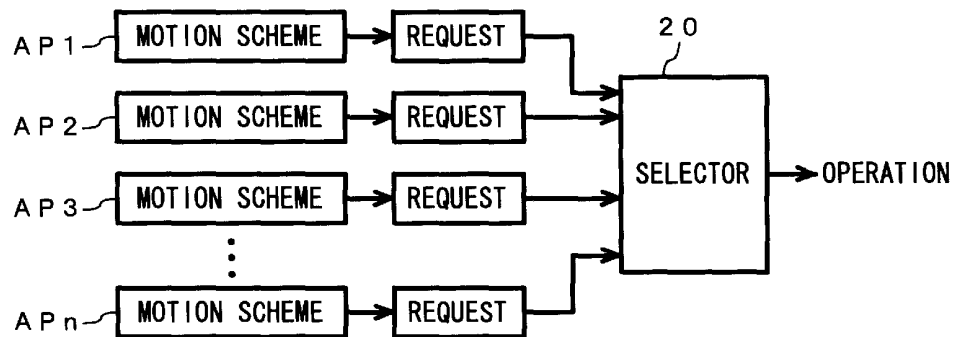

FIG. 5A

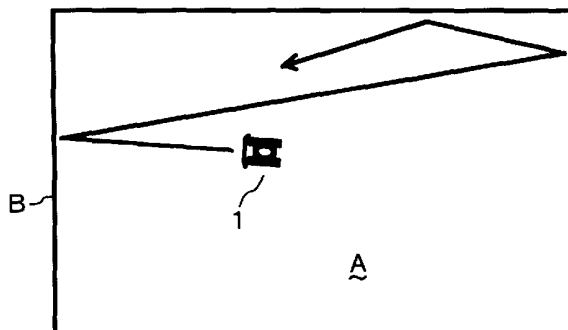

FIG. 5B

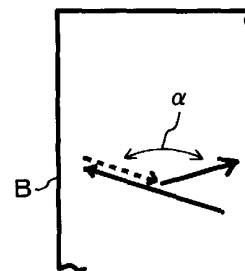

FIG. 6B

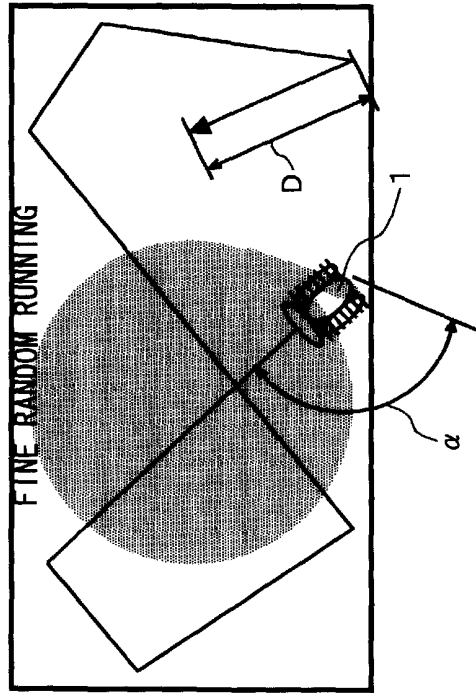

FIG. 6A

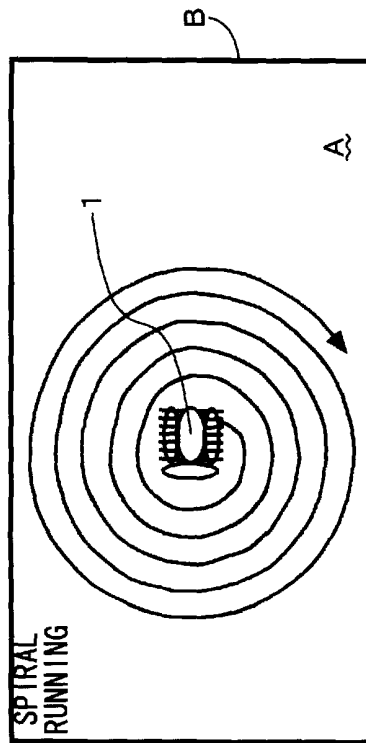

FIG. 6C

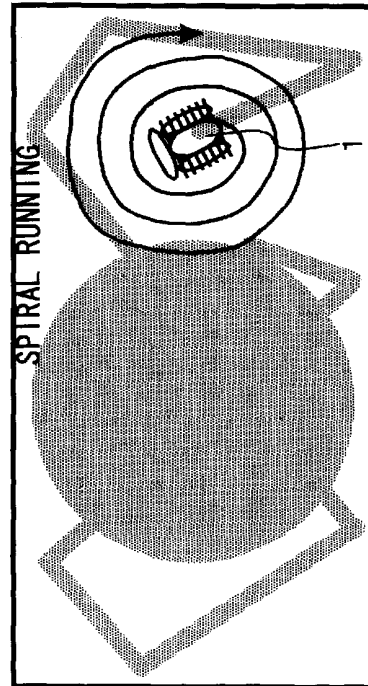

FIG. 7A

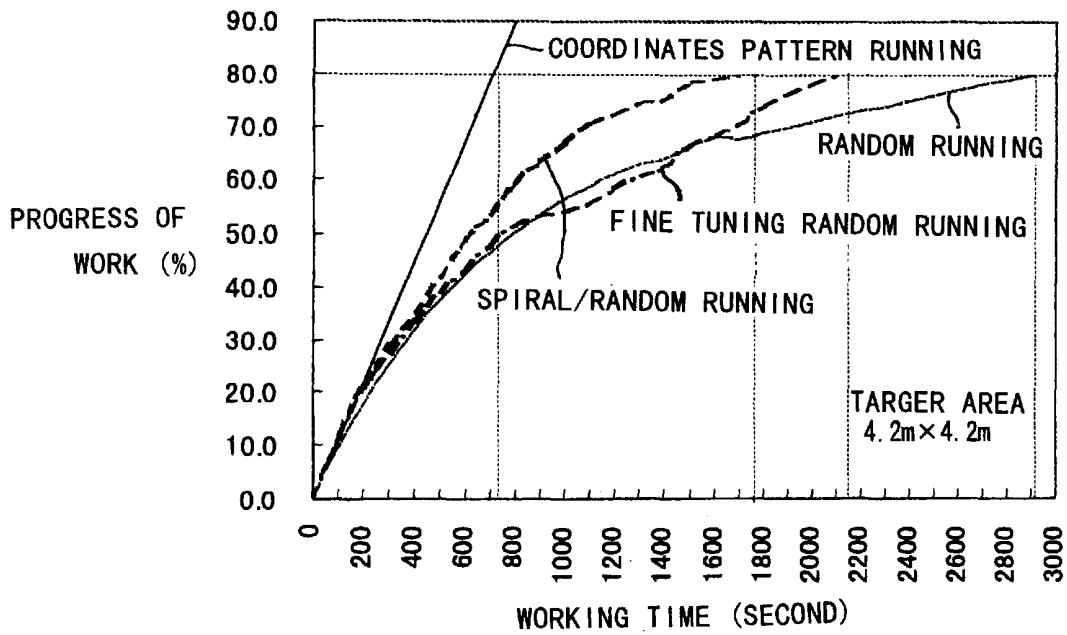
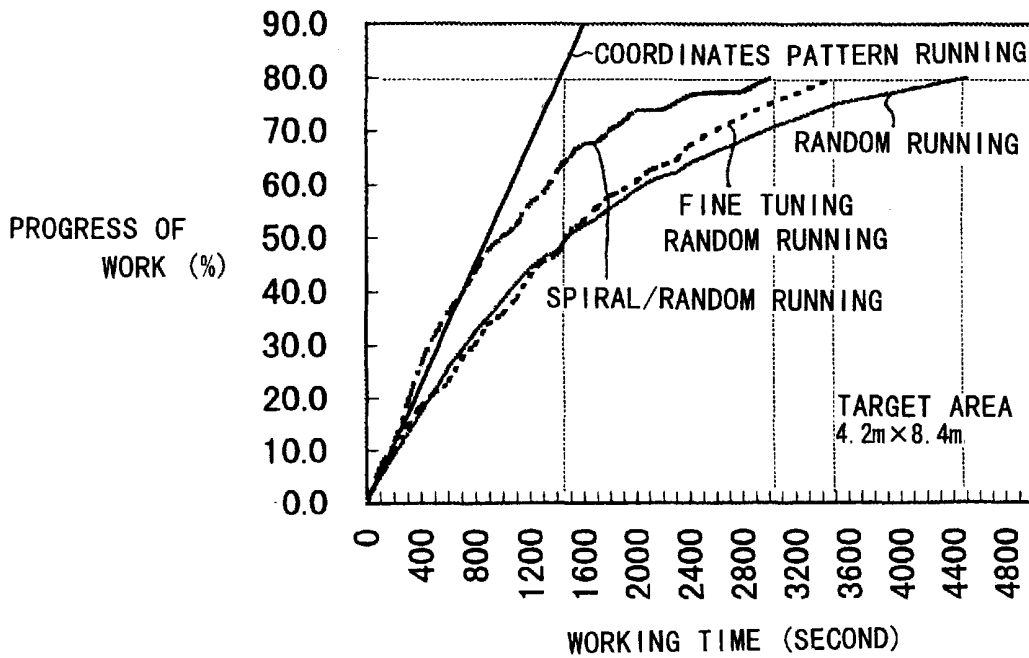

FIG. 7B



Explore Litigation Insights

Docket Alarm provides insights to develop a more informed litigation strategy and the peace of mind of knowing you're on top of things.

Real-Time Litigation Alerts



Keep your litigation team up-to-date with **real-time alerts** and advanced team management tools built for the enterprise, all while greatly reducing PACER spend.

Our comprehensive service means we can handle Federal, State, and Administrative courts across the country.

Advanced Docket Research



With over 230 million records, Docket Alarm's cloud-native docket research platform finds what other services can't. Coverage includes Federal, State, plus PTAB, TTAB, ITC and NLRB decisions, all in one place.

Identify arguments that have been successful in the past with full text, pinpoint searching. Link to case law cited within any court document via Fastcase.

Analytics At Your Fingertips



Learn what happened the last time a particular judge, opposing counsel or company faced cases similar to yours.

Advanced out-of-the-box PTAB and TTAB analytics are always at your fingertips.

API

Docket Alarm offers a powerful API (application programming interface) to developers that want to integrate case filings into their apps.

LAW FIRMS

Build custom dashboards for your attorneys and clients with live data direct from the court.

Automate many repetitive legal tasks like conflict checks, document management, and marketing.

FINANCIAL INSTITUTIONS

Litigation and bankruptcy checks for companies and debtors.

E-DISCOVERY AND LEGAL VENDORS

Sync your system to PACER to automate legal marketing.