



# United States Patent [19]

[11] **Patent Number:** **5,807,267**

**Bryars et al.**

[45] **Date of Patent:** **Sep. 15, 1998**

- [54] **HEART PULSE MONITOR** 5,243,992 9/1993 Eckerle et al. .... 128/690
- 5,301,154 4/1994 Suga ..... 128/690
- [75] Inventors: **John D. Bryars**, Encinitas; **David Cavanaugh**, San Diego, both of Calif. 5,431,170 7/1995 Mathews ..... 128/666
- 5,539,706 7/1996 Takenaka et al. .... 128/690
- 5,558,096 9/1996 Palatnik ..... 128/687

[73] Assignee: **Advanced Body Metrics Corporation**, Rancho Santa Fe, Calif.

*Primary Examiner*—Robert L. Nasser  
*Attorney, Agent, or Firm*—G. Donald Weber, Jr.

[21] Appl. No.: **512,712**

[57] **ABSTRACT**

[22] Filed: **Aug. 8, 1995**

The invention herein described is intended to provide the user with a reliable heart rate monitor that is a completely self contained unit and is capable of providing accurate readings while the wearer is moving about. The use of piezoelectric sensing elements eliminates the power drain caused by LEDs and similar devices. The sensing element mounting means disclosed herein is devised to greatly reduce the noise introduced into the pulse signal by body motion. The use of optical sensors in a staring mode and optical sensors in a pulsed mode is also presented. The effects of noise are further reduced by employing digital signal processing algorithms to find the heart pulse inter-mixed with noise signals and present the heart pulse rate in beats per minute on a display. The resulting device permits the visual monitoring of the heart pulse rate in a human body in a consistent, error-free manner.

### Related U.S. Application Data

[63] Continuation-in-part of Ser. No. 462,152, Jun. 5, 1995, which is a continuation of Ser. No. 252,605, Jun. 1, 1994, abandoned.

[51] **Int. Cl.<sup>6</sup>** ..... **A61B 5/00**

[52] **U.S. Cl.** ..... **600/500; 600/477; 600/479; 600/503**

[58] **Field of Search** ..... 128/672, 666, 128/687-690, 706, 707; 600/500-503; 5/476-475

### References Cited

#### U.S. PATENT DOCUMENTS

- 5,000,188 3/1991 Kojima ..... 128/687
- 5,197,489 3/1993 Conlan ..... 128/690

**27 Claims, 4 Drawing Sheets**

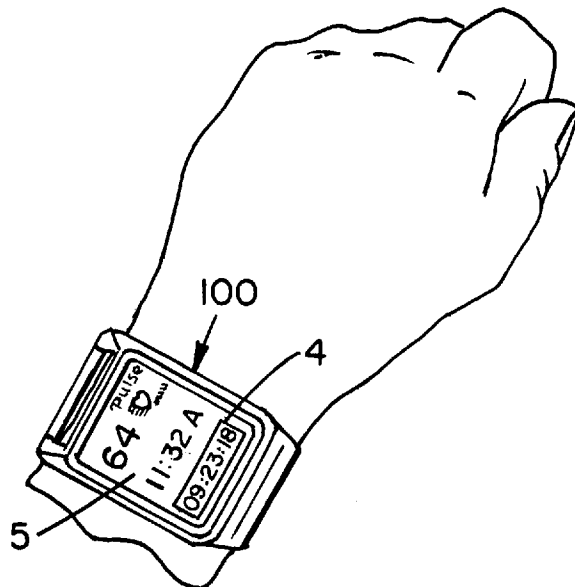

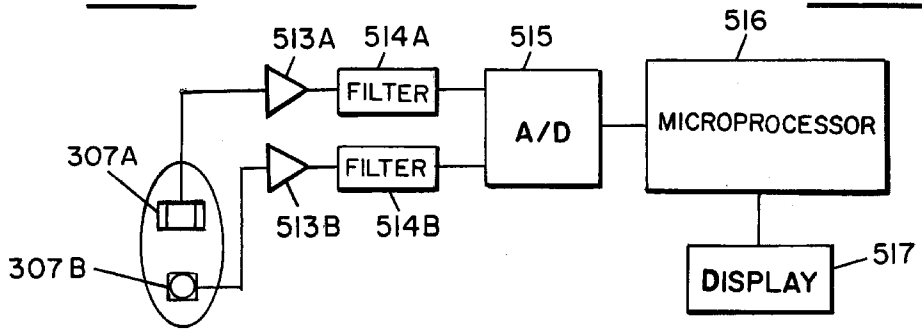
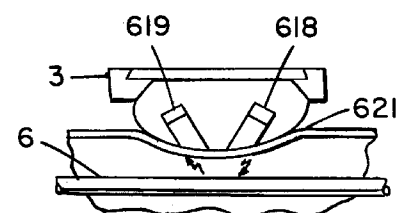
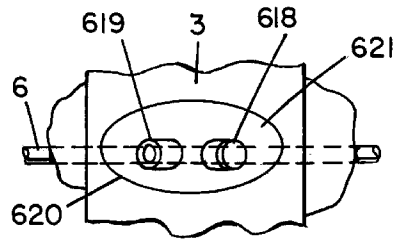
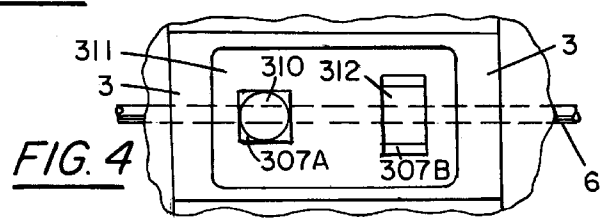
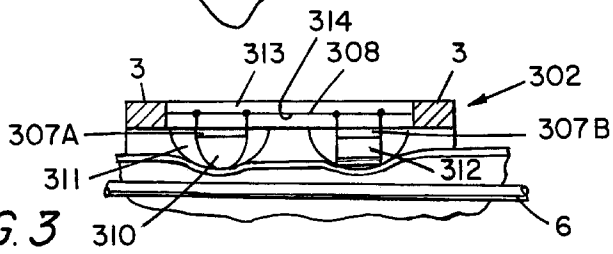
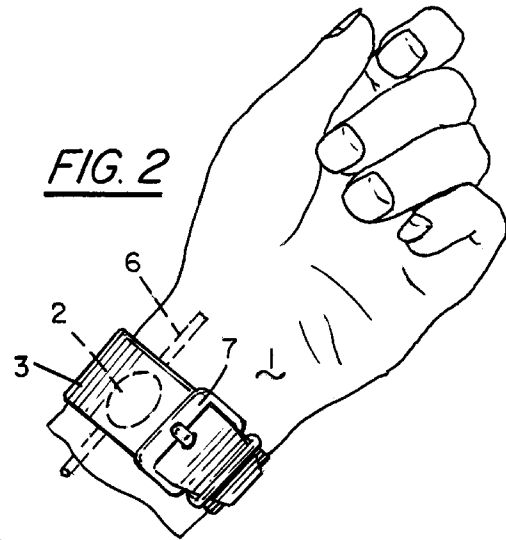
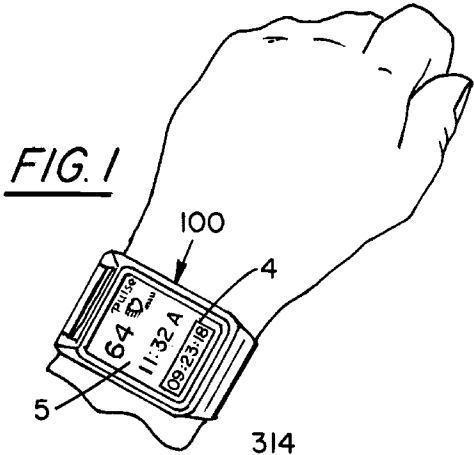

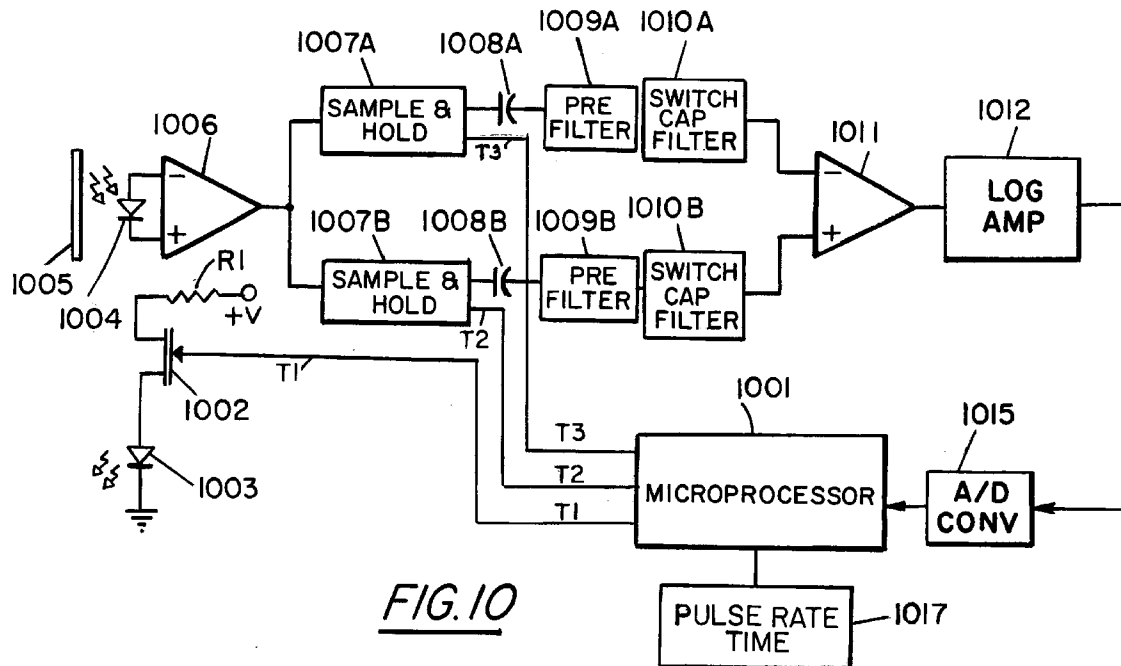
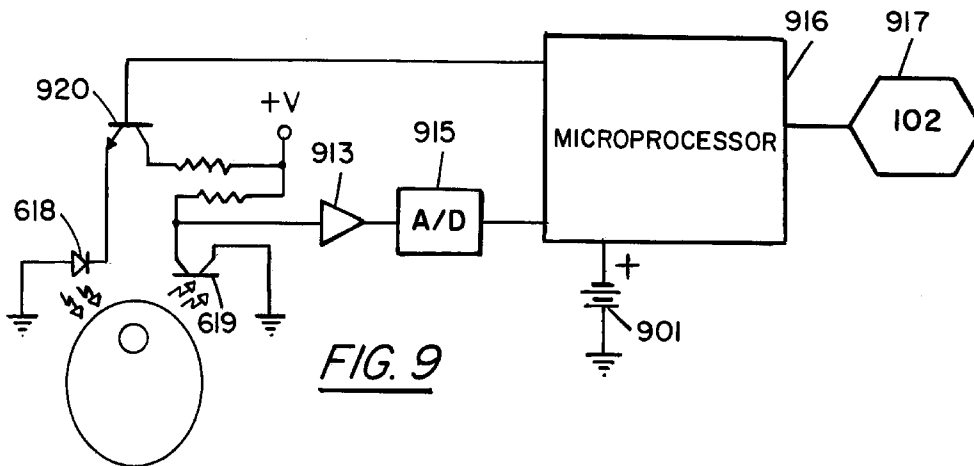
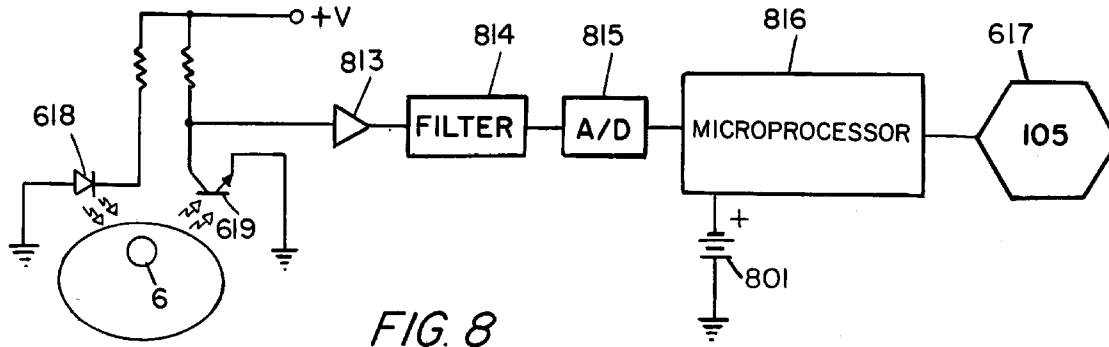

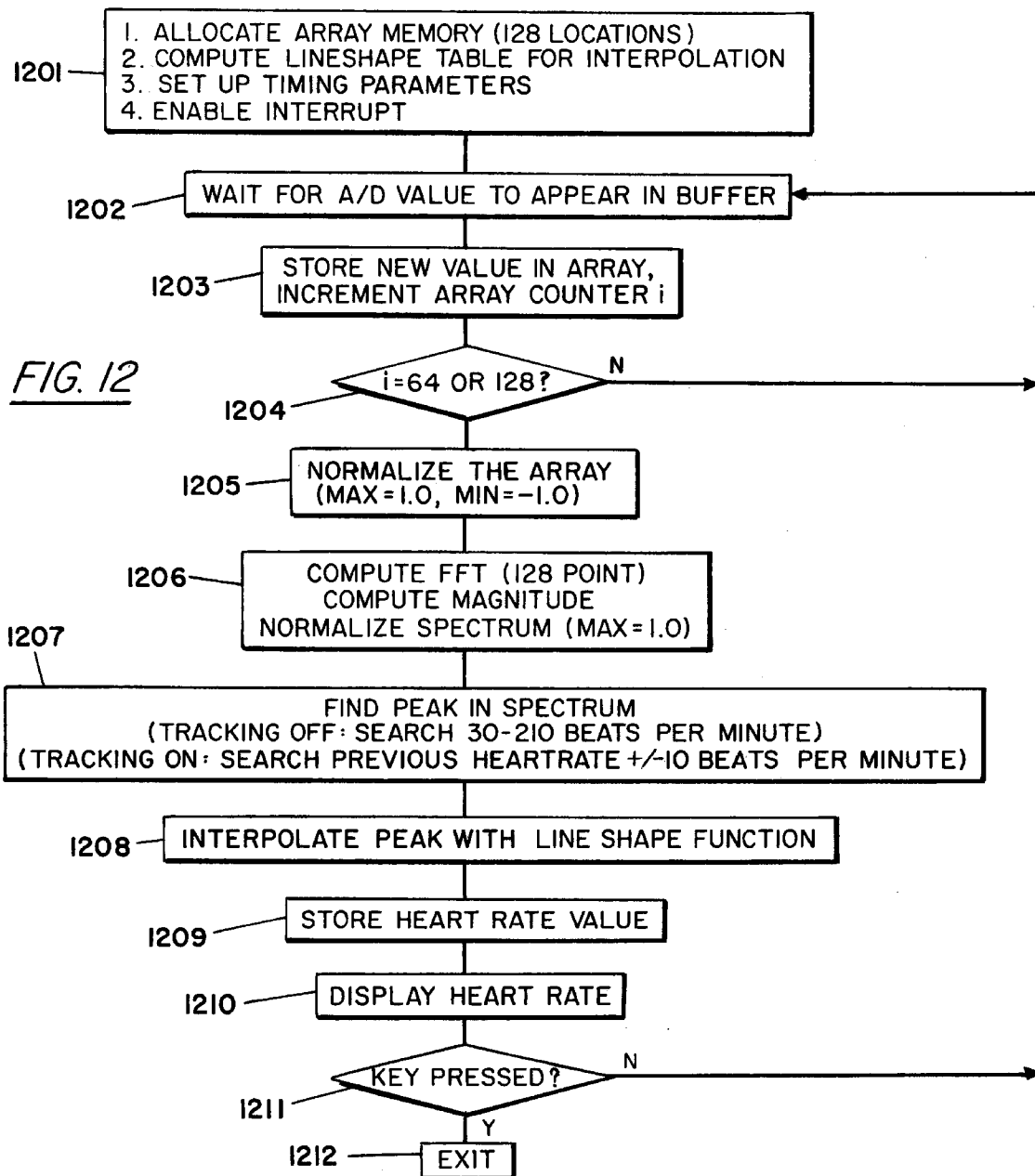
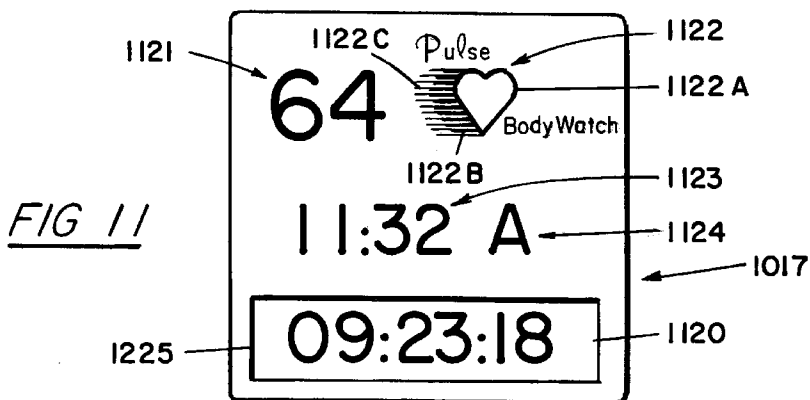

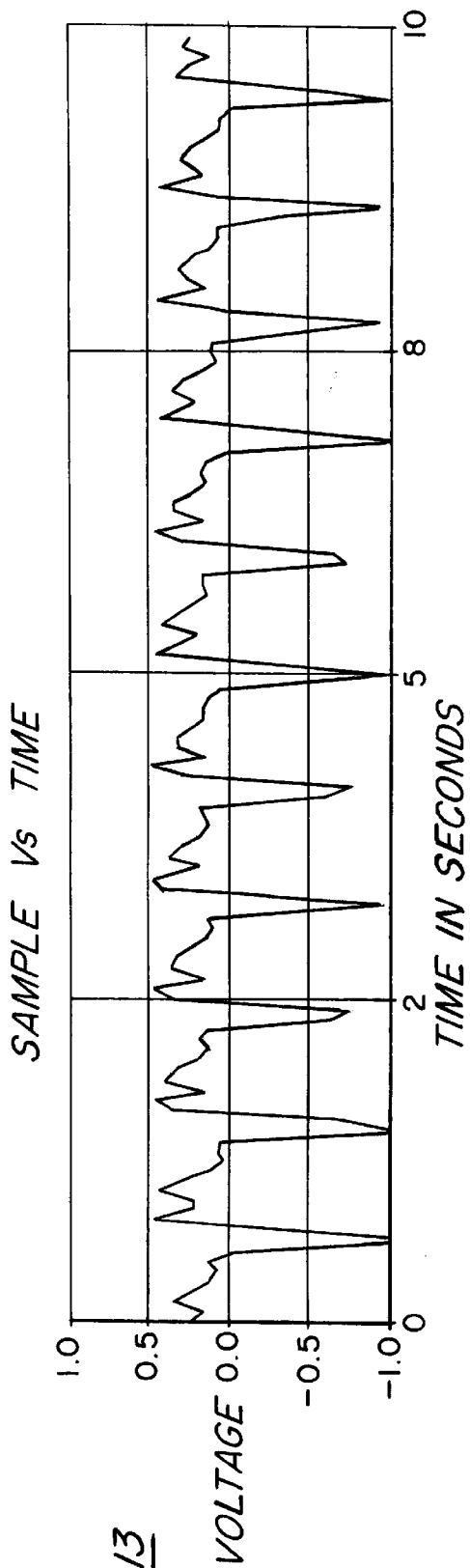

FIG. 13

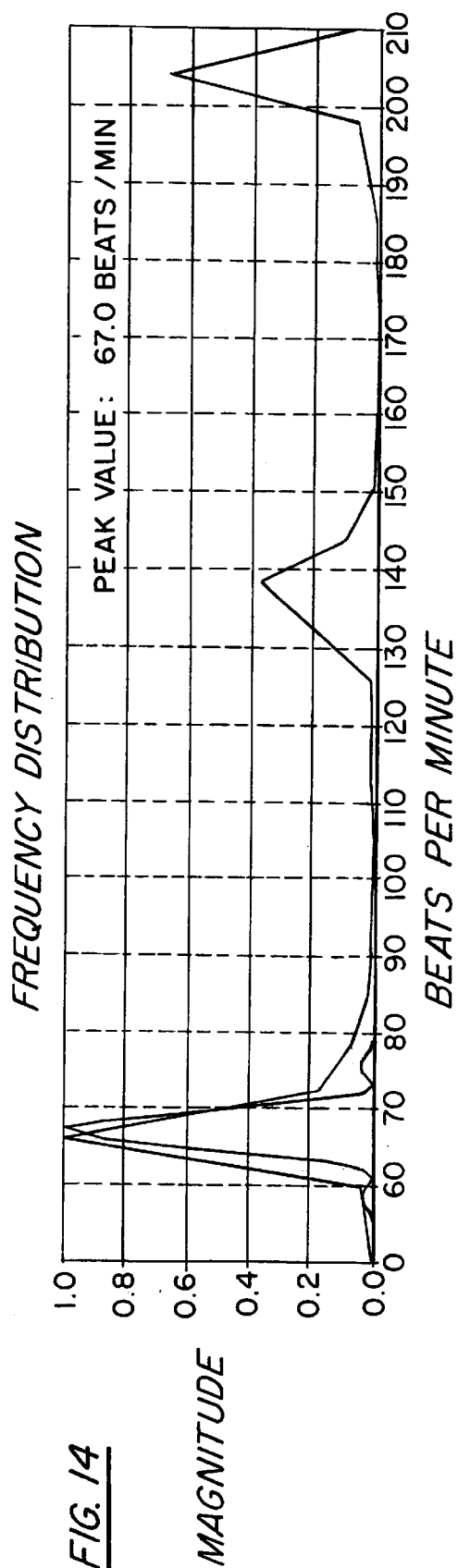

FIG. 14

# Explore Litigation Insights

Docket Alarm provides insights to develop a more informed litigation strategy and the peace of mind of knowing you're on top of things.

## Real-Time Litigation Alerts



Keep your litigation team up-to-date with **real-time alerts** and advanced team management tools built for the enterprise, all while greatly reducing PACER spend.

Our comprehensive service means we can handle Federal, State, and Administrative courts across the country.

## Advanced Docket Research



With over 230 million records, Docket Alarm's cloud-native docket research platform finds what other services can't. Coverage includes Federal, State, plus PTAB, TTAB, ITC and NLRB decisions, all in one place.

Identify arguments that have been successful in the past with full text, pinpoint searching. Link to case law cited within any court document via Fastcase.

## Analytics At Your Fingertips



Learn what happened the last time a particular judge, opposing counsel or company faced cases similar to yours.

Advanced out-of-the-box PTAB and TTAB analytics are always at your fingertips.

## API

Docket Alarm offers a powerful API (application programming interface) to developers that want to integrate case filings into their apps.

## LAW FIRMS

Build custom dashboards for your attorneys and clients with live data direct from the court.

Automate many repetitive legal tasks like conflict checks, document management, and marketing.

## FINANCIAL INSTITUTIONS

Litigation and bankruptcy checks for companies and debtors.

## E-DISCOVERY AND LEGAL VENDORS

Sync your system to PACER to automate legal marketing.