

THE NETWORK VEHICLE – A GLIMPSE INTO THE FUTURE OF MOBILE MULTI-MEDIA

*R. Lind, R. Schumacher, R. Reger, R. Olney, H. Yen and M. Laur
Delphi Delco Electronics Systems, Kokomo, Indiana*

R. Freeman

IBM Corporation, White Plains, New York

ABSTRACT

The Network Vehicle is the Delphi Automotive Systems' vision for the future convergence of computers, the communications infrastructure, and the automobile. It features many advanced functions such as: satellite video, Internet access, virtual navigation, remote vehicle diagnostics and control, games, mobile office, automotive web site, and customized real-time stock quotes and sports scores. These features are enabled by an integrated planar antenna that is capable of multiple satellite reception, a client-server network architecture, and unique human-vehicle-interfaces such as color reconfigurable head up and head down displays, steering wheel controls, voice recognition, text-to-speech, and large touch screen active matrix liquid crystal displays (LCD's). The software applications are written in Java, using Application Programming Interfaces (API's) to reduce the complexity and cost of the source code.

INTRODUCTION

The Network Vehicle, a new technology initiative by Delphi Delco Electronics Systems and its partners (IBM, Netscape Communications, and Sun Microsystems) is aimed at offering more productivity tools, convenience, safety, and 0-7803-5086-3 /98/\$10.00 ©1998 IEEE

entertainment to millions of commuters who spend hours each day cruising the roads or stuck in traffic. It is designed to demonstrate what technologies and software can do for the vehicle of the future. The Network Vehicle, pictured in Figure 1, made its debut at COMDEX '97 and has since been all over the world appearing in demos, conferences, and technology shows, including SAE Congress '98, and CeBit '98.



Figure 1. The Network Vehicle

SYSTEM OVERVIEW

The Network Vehicle is created by integrating existing hardware and software technologies including voice recognition, wireless communications, global positioning via satellite, head-up displays, Java™ technology, microprocessors, Web access, and

I21-1

other Internet/intranet features. The voice recognition technology allows drivers and passengers to verbally request and listen to e-mail messages, locate a restaurant or hotel, ask for navigation help or for specific music or sports scores, and use voice-activated telephone services, all done safely without interfering with driving. Drivers can use a head-up display projected through the windshield to navigate to their destination or check vehicle functions without taking their eyes off the road.

Passengers using individual terminals next to their seats can do even more, including interacting with the Internet, watching television or playing games. Existing services such as theft deterrent technologies and emergency services could also be integrated. These "smart" features are enabled mainly because of the real-time data-streaming capabilities over a wireless network using Java-based technology. The Network Vehicle also has an integrated cellular phone, Netscape Communicator software for Web browsing and e-mail, a removable personal digital assistant (PDA) and docking station. There is also a vehicle web site that provides driver support for a wide array of customized capabilities such as enabling remote monitoring and control of vehicle systems in emergency situations.

Onboard And Off-Board Communications Networks

The key to the functions of the Network Vehicle is its ability to communicate efficiently both onboard and off-board of the vehicle. Figure 2 depicts the onboard network architecture of the vehicle.

At the heart of the onboard system is a network computer that links up a number of sub-networks, including a Class II bus (for engine, head-up and head-down displays, door lock and door actuator, RFID, and cell phone, etc.), an Ethernet (for passenger computers and displays), and a mobile media link (for speakers and CD players). Since the subnetworks all have different clock speed and

functionality, gateways are used to translate the messages from one sub-network to another so as to ensure harmonious operations.

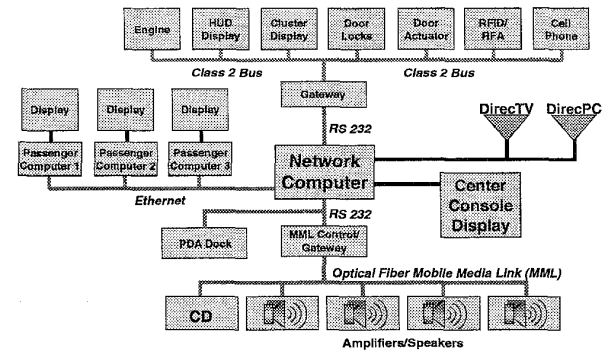
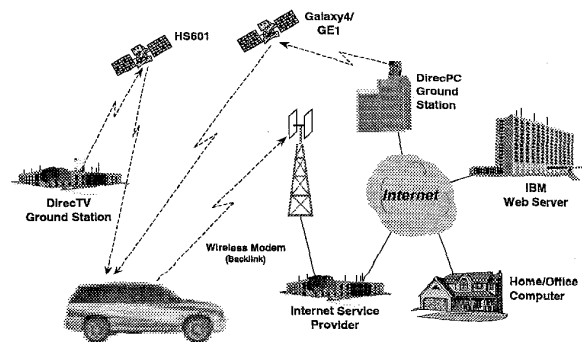

Figure 2. Onboard Network Architecture

The off-board network is shown in Figure 3. The high bandwidth requirements for on-demand audio and video functions are fulfilled with DirecPC and DirecTV satellite broadcasts. A wireless modem provides the uplink out of the vehicle directly to Internet service providers. The downlink return path from the Internet to the Network Vehicle can come through either the satellite (400 kbps), or through the wireless modem. The downlink satellite video and data signals are collected by the Network Vehicle's roof-mounted antenna and processed by their respective receivers.

Figure 3. Off-Board Network Architecture



In order to take full advantages of the resources and services available to the drivers and passengers, the vehicle must have robust external communications paths. It is also vitally important that the vehicle configuration includes a firewall to ensure the integrity of the

vehicle operation. This means that regardless of what happens to the multimedia applications that are running in the vehicle, the powertrain system control, the chassis control, brakes, airbags, and other critical functions must maintain their integrity. In the Network Vehicle, this isolation is implemented through multiple gateways as shown in Figure 2.

KEY TECHNOLOGIES AND SYSTEM COMPONENTS

The key technologies and system components behind the Network Vehicle are advanced speech recognition software, mobile media link (high-speed fiber optic data bus), reconfigurable head-up display, high-bandwidth communications that connect the vehicle with the outside world, and a suite of automotive computer software. These elements are described below.

Speech Recognition and Text-to-Speech System

IBM has modified its advanced speech recognition and text-to-speech system, ViaVoice™, for the automotive environment. ViaVoice allows the driver to access virtually all the vehicle's features through voice commands and enables the vehicle to talk back using synthesized speech. For example, the driver can: execute vehicle system commands such as lock doors, play CD, and change radio station, request travel directions and traffic updates from the Web or other sources, check e-mail and voicemail, request news, sports, and stock information. The speech recognition system can understand most drivers instantly, with no system training required, and it has been tuned to offer optimal performance even in a potentially noisy vehicle environment.

Driver and Center Console Displays

The Network Vehicle is equipped with three displays for the driver: the head-down

display (HDD), the head-up display (HUD), and the center console display.

The HDD system displays standard graphics for an instrument panel: road speed, engine speed, engine status, door lock/ajar, and fuel level. It also displays the functions for the steering wheel buttons since these functions vary with the entertainment mode that is selected. The HUD projects a virtual image through the windshield that gives information to drivers without requiring them to take their eyes off the road. It displays road speed, engine status, waiting e-mail indication, navigation information, microphone on/off, and a text message area for giving feedback to the driver.

The center console's touch-screen LCD serves as a user interface for controlling nearly all of the Network Vehicle's multimedia functions, (office, navigation, entertainment, and information). When in entertainment mode, the display is configured as a radio- or CD-style faceplate whose buttons and controls are activated by touch (see Figure 4). It is reconfigured to display e-mail, navigation maps, Web browser, cellular phone faceplate (shown in Figure 5), and more. Voice-activated commands can be used with all of the center console functions and, in some cases, is



combined with text-to-speech input to minimize driver distraction.

Figure 4. Audio on Demand Faceplate



Figure 5. Cellular Phone Faceplate Display

Passenger Displays

The Network Vehicle has color LCD touch panels for the back-seat and front-seat passengers. As with the center console display, the passenger displays serve as user interfaces for controlling nearly all of the functions on the Network Vehicle. Unlike the center console display, however, the passenger displays can show video from DirecTV or DVD players, and they allow touch-screen access to all functions.

Planar Satellite Antenna

The antenna technology used in the Network Vehicle is the Continuous Transverse Stub (CTS) array. It is chosen because of its simplicity, planar construction, and potential for being an inexpensive product. Figure 6 shows the cross sectional view of a typical CTS antenna, realized as an array of broad continuous transverse radiating stubs, finite in height, extending from the upper conductive plate of an open parallel-plate transmission-line structure.

As a receiving antenna, the induced longitudinal current components in the parallel plate structure are interrupted by the transverse-oriented stubs and excite propagating waves in the parallel-plate structure. This simple architecture allows for a complex two-dimensional planar array to be realized as an

“extrusion” of a one-dimensional (constant cross-section) geometry. This has the effect of replacing a conventional “ $N \times N = N^2$ ” element structure (of discrete radiators, couplers, etc.) with a less complex “monolithic” array comprised of “ N ” integrated coupler/radiator features. The simple “tee” cross-section of the integrated CTS coupler/radiator forms an inherently low-“ Q ” (non-resonant) element which exhibits significant advantages (as compared to slot or patch radiators) in terms of wide-angle scanning capability, polarization purity, bandwidth, and dimensional insensitivity.

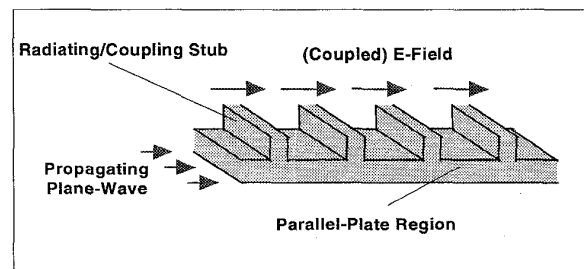

Figure 6. CTS Antenna Cross Section

Customer Application Web Site

The driver and passengers of the Network Vehicle can take advantage of Internet services provided by automotive-oriented ISPs (Internet Service Providers). The customer service site developed for the Network Vehicle showcases the types of features that could be offered when intelligent vehicle systems are connected to the Internet.

Because the Network Vehicle's systems are accessible via its command and control application, which also has secure access to the Internet, many scenarios are possible. Functions like parking lights and door locks on the Network Vehicle can be controlled remotely, providing safety and convenience. An example of such a web page is shown in Figure 7.

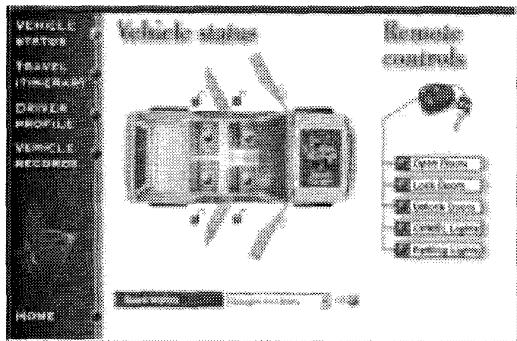

Figure 7. Monitor and Control of Vehicle Status via Internet

Under voice control of the driver, the Network Vehicle can upload vehicle status according to a profile set up in advance. An application monitors the diagnostic information available from components in the engine compartment. Should the diagnostics indicate that the latest reading from engine sensors falls outside a normal range, the application can notify the customer service Web site, where the severity of the reading can be determined. According to this determination, the control on the Network Vehicle could be used by the service representative to alert the driver; the alert could be done using text-to-speech and head-up display, and then features of the application, e-mail, and office could be used to arrange a service appointment. Figure 8 illustrates the sensor data that are being monitored through the vehicle web site.

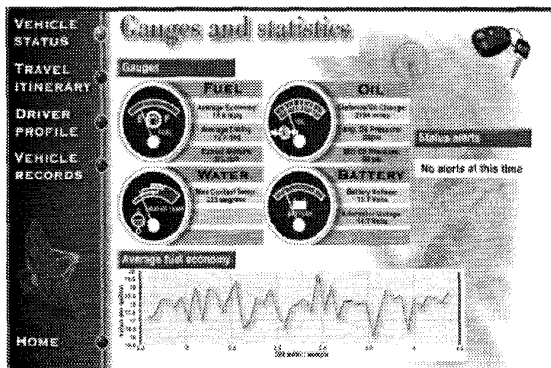

Figure 8. Remote Monitoring of Vehicle Gauges via a Web Site

Other features demonstrated take advantage of Internet service providers' ability to communicate with the Network Vehicle. Trip plans created by vehicle owners or concierge services can be stored at the Internet service provider. By accessing global positioning satellite (GPS) data directly from the vehicle, the driver and passengers can obtain maps, route guidance, fuel, lodging, and restaurant information while traveling. Owners of the Network Vehicle can also use their Web browser to set up a profile, including preferences like radio stations, personalized audio content, service records, and emergency service numbers.

Personal Digital Assistant Docking

An important role of the Network Vehicle is providing office functions to mobile users, using the same data the users have in their office desktop computers. This function is mainly provided through vehicle applications, Internet connectivity, and advanced, voice-based user interfaces. It is important for the Network Vehicle to access and synchronize personal and business data with PDAs, which is becoming increasingly important in our mobile, connected world.

A slot built into the center console of the Network Vehicle accepts the IBM WorkPad™ and uses the Network Vehicle's computer to add speech recognition and text-to-speech functions. This enables the driver to listen to schedules and to update files and other office data stored in the WorkPad. So the driver could, for example, issue a voice command to read calendar entries from the WorkPad or dictate a to-do list while driving. As PDA and smart card technology advances, the Network Vehicle's PDA integration could support the use of PDA-type devices for the secure transport and access of personal, financial, and business information as people move from one network access point to another.

Explore Litigation Insights

Docket Alarm provides insights to develop a more informed litigation strategy and the peace of mind of knowing you're on top of things.

Real-Time Litigation Alerts



Keep your litigation team up-to-date with **real-time alerts** and advanced team management tools built for the enterprise, all while greatly reducing PACER spend.

Our comprehensive service means we can handle Federal, State, and Administrative courts across the country.

Advanced Docket Research



With over 230 million records, Docket Alarm's cloud-native docket research platform finds what other services can't. Coverage includes Federal, State, plus PTAB, TTAB, ITC and NLRB decisions, all in one place.

Identify arguments that have been successful in the past with full text, pinpoint searching. Link to case law cited within any court document via Fastcase.

Analytics At Your Fingertips



Learn what happened the last time a particular judge, opposing counsel or company faced cases similar to yours.

Advanced out-of-the-box PTAB and TTAB analytics are always at your fingertips.

API

Docket Alarm offers a powerful API (application programming interface) to developers that want to integrate case filings into their apps.

LAW FIRMS

Build custom dashboards for your attorneys and clients with live data direct from the court.

Automate many repetitive legal tasks like conflict checks, document management, and marketing.

FINANCIAL INSTITUTIONS

Litigation and bankruptcy checks for companies and debtors.

E-DISCOVERY AND LEGAL VENDORS

Sync your system to PACER to automate legal marketing.