

- [54] **AUTOMOBILE NAVIGATION SYSTEM USING REMOTE DOWNLOAD OF DATA**
- [75] Inventor: **Hidekazu Oshizawa**, Cupertino, Calif.
- [73] Assignee: **Visteon Technologies, LLC**, Sunnyvale, Calif.
- [21] Appl. No.: **08/816,107**
- [22] Filed: **Mar. 11, 1997**
- [51] **Int. Cl.<sup>6</sup>** ..... **G06F 165/00**
- [52] **U.S. Cl.** ..... **701/209; 701/202; 701/210; 340/990; 340/995**
- [58] **Field of Search** ..... **701/202, 207, 701/208, 209, 210, 211; 73/178 R; 340/988, 990, 995, 989**

**OTHER PUBLICATIONS**

Duncan, Don, "RESCU, remote emergency satellite cellular unit," *Proceedings of the National Technical Meeting, Institute of Navigation 1996*, E.I. Conference No. 45483, pp. 361-366.

Abstract, Martin, Norman, "Look to the sky automakers plug into automatic communication systems," *Chilton's Automotive Industries*, v. 176, No. 3, Mar. 1996, pp. 74-75.

Abstract, Demmler, Al, "OnStar," *Automotive Engineering*, v. 104, Jun. 1996, pp. 85-86.

Abstract, Mateja, Jim, "Safety system dials 9-1-1 for motorists," *Traffic Safety*, v. 96, Jul./Aug. 1996, pp. 4-5.

Abstract, Schofield, Julie Anne, "Electronics create the cybercar," *Design News*, v. 50[51], Oct. 9, 1995, pp. 116-118.

*Primary Examiner*—Gary Chin  
*Attorney, Agent, or Firm*—Blakely, Sokoloff, Taylor & Zafman LLP

[56] **References Cited**

**U.S. PATENT DOCUMENTS**

4,301,506	11/1981	Turco	364/436
4,350,970	9/1982	von Tomkewitsch	340/23
4,796,191	1/1989	Honey et al.	364/450
4,812,843	3/1989	Champion, III et al.	340/905
4,914,605	4/1990	Loughmiller, Jr. et al.	364/518
4,954,958	9/1990	Savage et al.	701/202
5,172,321	12/1992	Ghaem et al.	340/995
5,177,685	1/1993	Davis et al.	364/443
5,184,303	2/1993	Link	364/449
5,523,950	6/1996	Peterson	364/436
5,544,061	8/1996	Morimoto et al.	701/202
5,745,867	4/1998	Mills	701/202
5,774,827	6/1998	Smith, Jr. et al.	701/202
5,845,227	12/1998	Peterson	701/209
5,862,509	1/1999	Desai et al.	701/202

**FOREIGN PATENT DOCUMENTS**

0123562	4/1984	European Pat. Off. .
WO 90/02391	8/1989	WIPO .
WO 92/10808	10/1991	WIPO .
WO 92/14215	2/1992	WIPO .

[57] **ABSTRACT**

A method of enabling an on-board vehicle navigation system to compute a route from a current position of the vehicle to a desired destination is provided. A user of the navigation system in a vehicle utilizes a cellular telephone or any other wireless, two-way audio communications link to contact an operator in a remote communications center. The user informs the operator of his desired destination. The operator in the communications center accesses a computer database to determine the exact location of the desired destination in terms of latitude/longitude, street address, or other similar information. The operator then causes the information specifying the exact location to be transmitted from the communications center to the on-board vehicle navigation system over a data link. The on-board vehicle navigation system receives the location information and uses it to compute a route from the vehicle's current position to the desired destination.

**43 Claims, 4 Drawing Sheets**

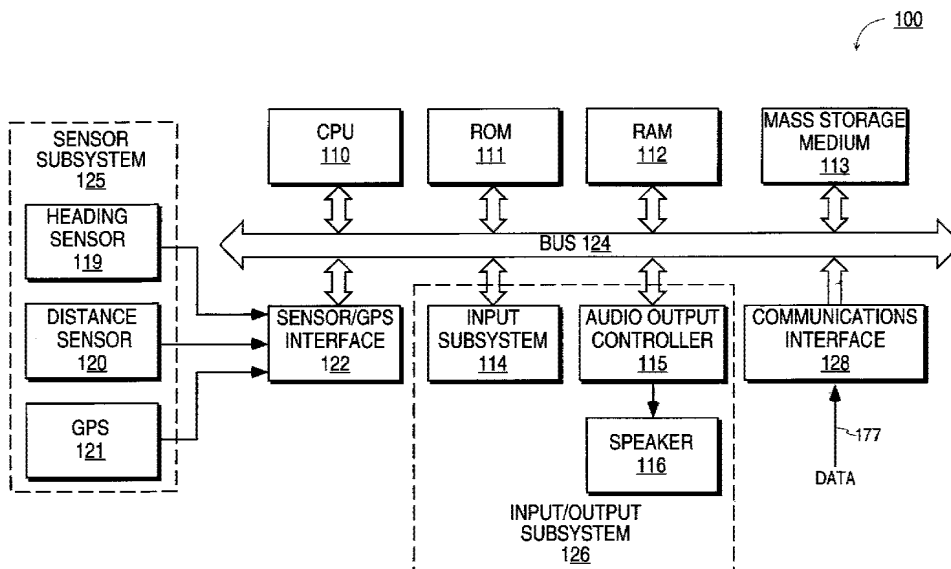
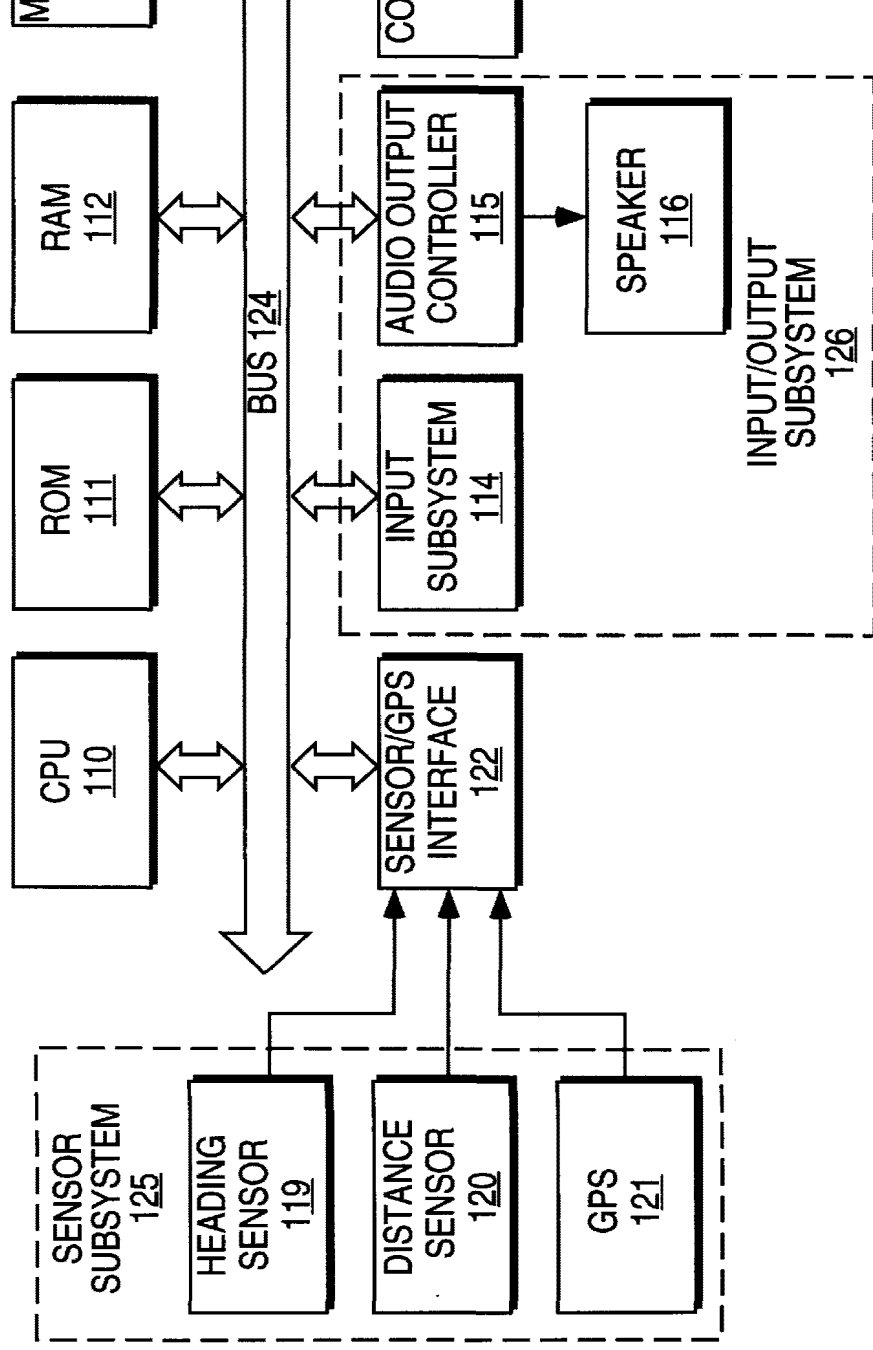
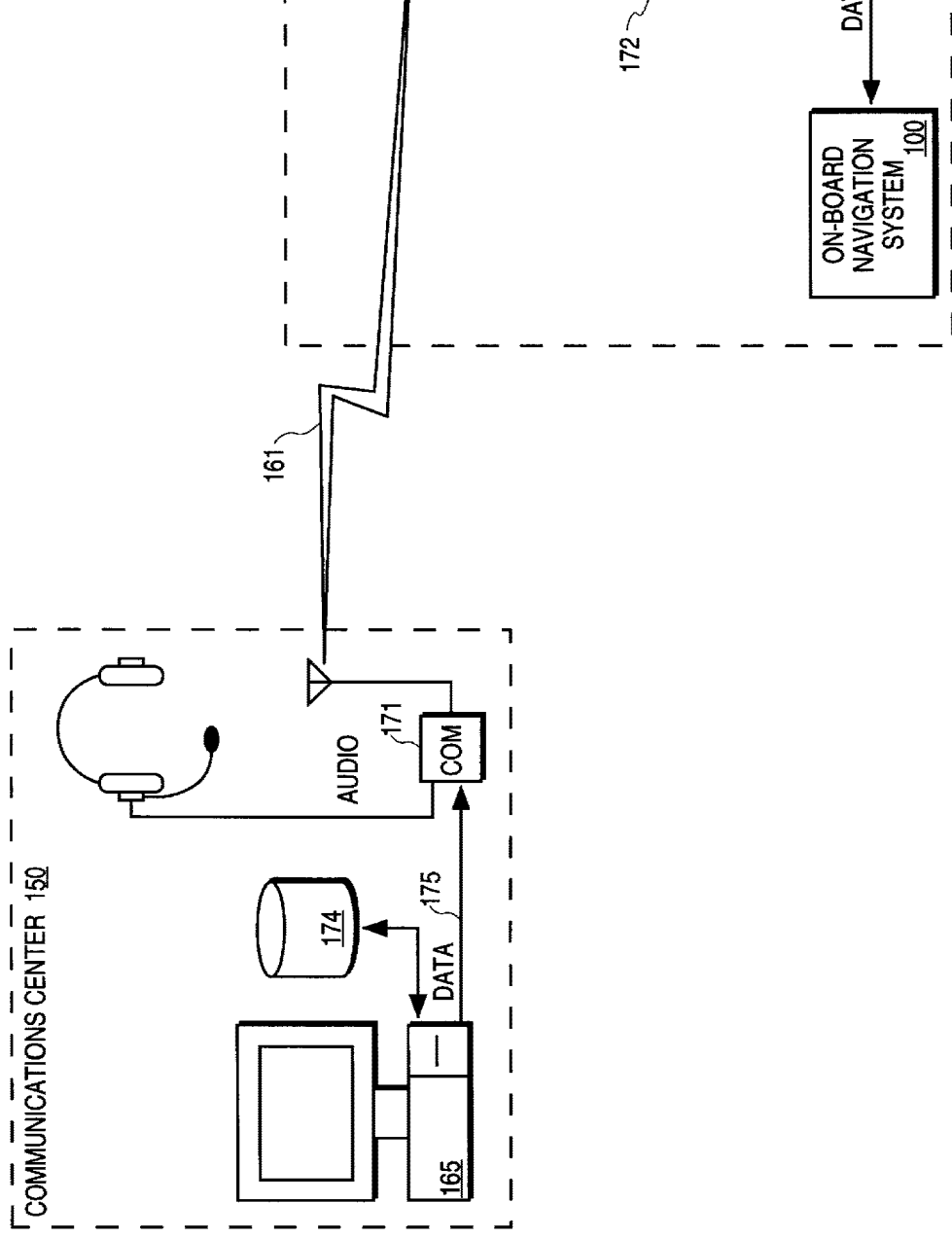
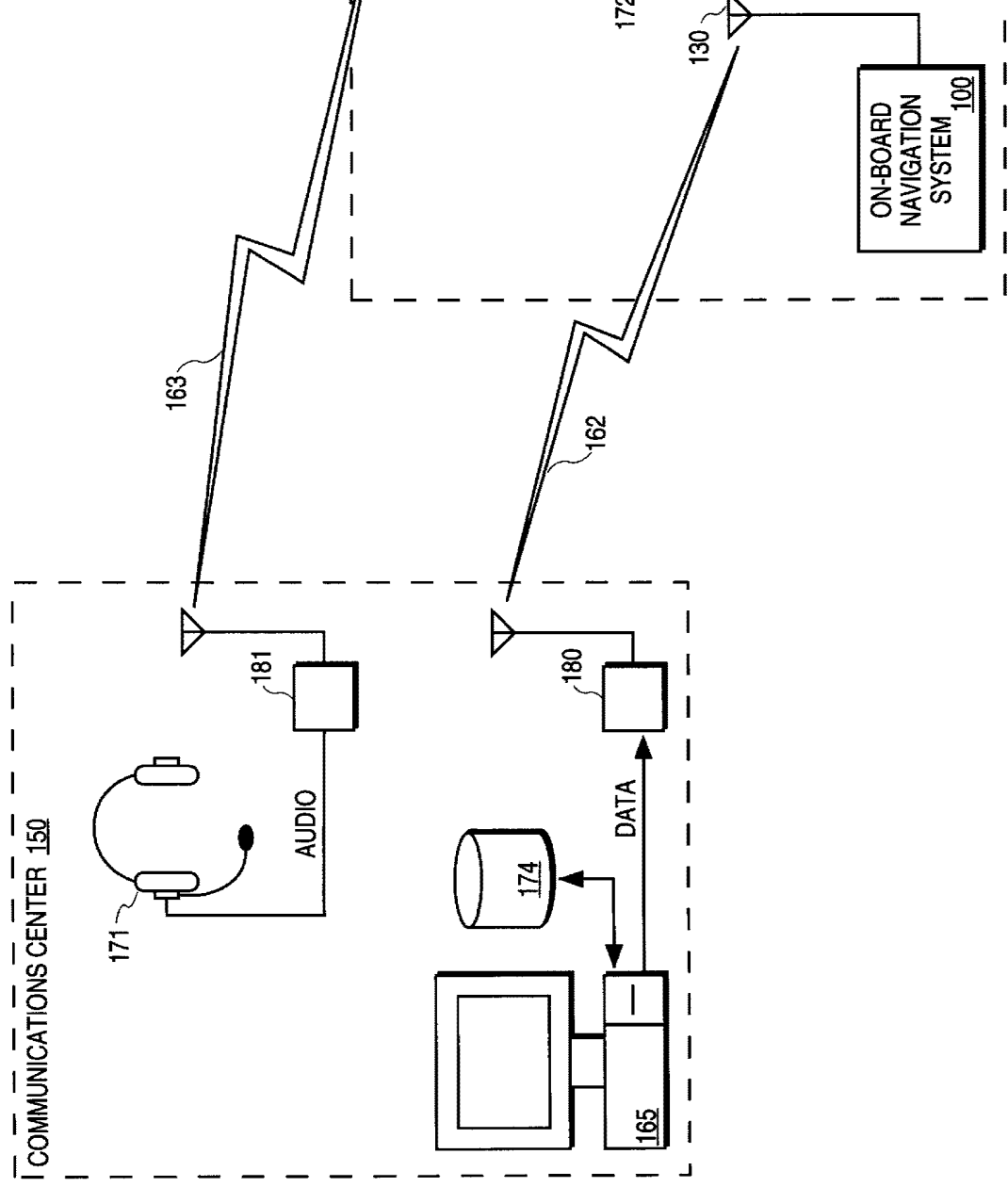

FIG. 1

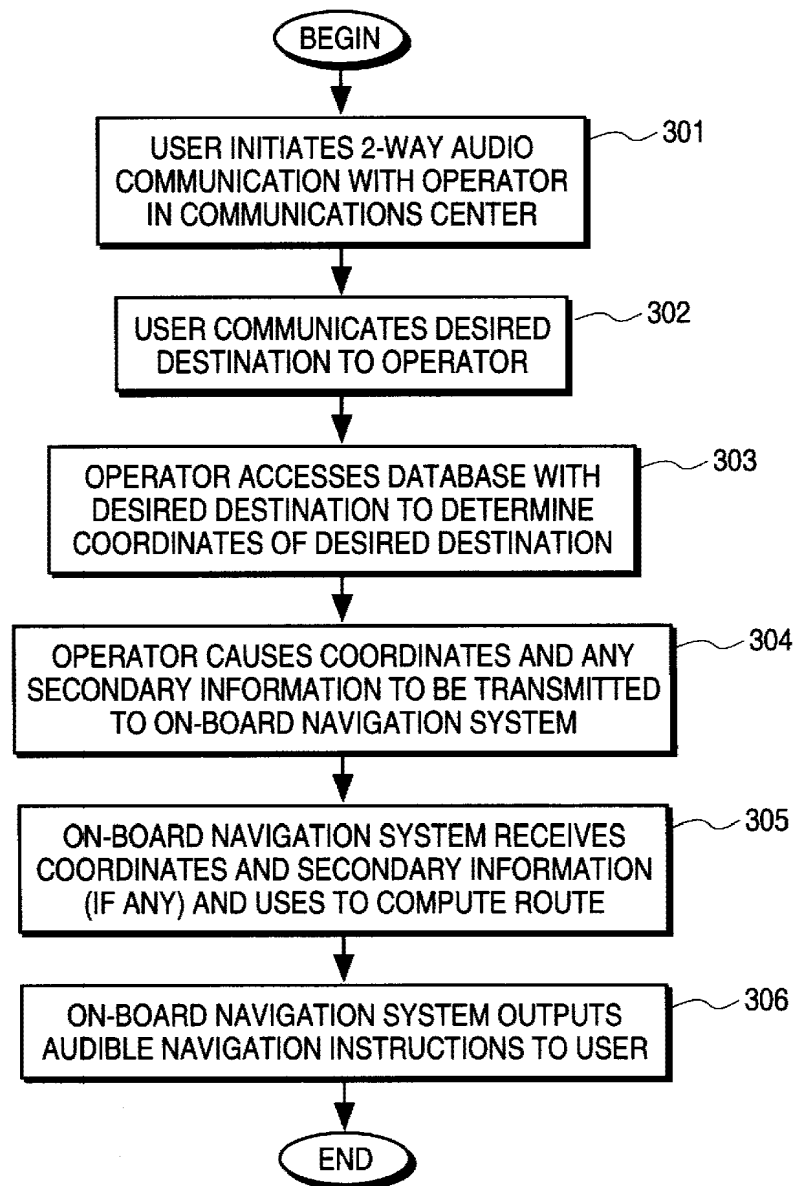



**FIG. 2A**



**FIG. 2B**

**FIG. 3**

# Explore Litigation Insights

Docket Alarm provides insights to develop a more informed litigation strategy and the peace of mind of knowing you're on top of things.

## Real-Time Litigation Alerts



Keep your litigation team up-to-date with **real-time alerts** and advanced team management tools built for the enterprise, all while greatly reducing PACER spend.

Our comprehensive service means we can handle Federal, State, and Administrative courts across the country.

## Advanced Docket Research



With over 230 million records, Docket Alarm's cloud-native docket research platform finds what other services can't. Coverage includes Federal, State, plus PTAB, TTAB, ITC and NLRB decisions, all in one place.

Identify arguments that have been successful in the past with full text, pinpoint searching. Link to case law cited within any court document via Fastcase.

## Analytics At Your Fingertips



Learn what happened the last time a particular judge, opposing counsel or company faced cases similar to yours.

Advanced out-of-the-box PTAB and TTAB analytics are always at your fingertips.

## API

Docket Alarm offers a powerful API (application programming interface) to developers that want to integrate case filings into their apps.

## LAW FIRMS

Build custom dashboards for your attorneys and clients with live data direct from the court.

Automate many repetitive legal tasks like conflict checks, document management, and marketing.

## FINANCIAL INSTITUTIONS

Litigation and bankruptcy checks for companies and debtors.

## E-DISCOVERY AND LEGAL VENDORS

Sync your system to PACER to automate legal marketing.