

UNITED STATES PATENT AND TRADEMARK OFFICE

---

BEFORE THE PATENT TRIAL AND APPEAL BOARD

---

SAMSUNG ELECTRONICS AMERICA, INC. and  
ASUS COMPUTER INTERNATIONAL, INC.,  
Petitioner,

v.

JAMES B. GOODMAN,  
Patent Owner

---

Case IPR2017-02021<sup>1</sup>  
Patent 6,243,315 B1

---

Before BRIAN J. McNAMARA, PATRICK M. BOUCHER, and  
KIMBERLY McGRAW, *Administrative Patent Judges*.

McGRAW, *Administrative Patent Judge*.

JUDGMENT  
Final Written Decision  
Determining Some Challenged Claims Unpatentable  
35 U.S.C. § 318(a)

---

<sup>1</sup> Case IPR2018-00047, filed by ASUS Computer International, Inc. (“ASUS”), has been joined with this proceeding.

## I. INTRODUCTION

In this *inter partes* review, instituted pursuant to 35 U.S.C. § 314, Samsung Electronics America, Inc. and ASUS Computer International, Inc. (collectively “Petitioner”) challenge the patentability of claims 1–20 (“the challenged claims”) of U.S. Patent No. 6,243,315 B1 (Ex. 1001, “the ’315 patent”<sup>2</sup>), owned by James B. Goodman (“Patent Owner”).

We have jurisdiction under 35 U.S.C. § 6. This Final Written Decision, issued pursuant to 35 U.S.C. § 318(a) and 37 C.F.R. § 42.73, addresses issues and arguments raised during trial. For the reasons discussed below, we determine that Petitioner has shown by a preponderance of the evidence that claims 1, 5, 10, and 16 of the ’315 patent are unpatentable but has not shown by a preponderance of the evidence that claims 2–4, 6–9, 11–15, and 17–20 are unpatentable.

### A. Procedural History

On August 29, 2017, Samsung Electronics America, Inc. filed a Petition requesting an *inter partes* review of claims 1–20 of the ’315 patent. Paper 2 (“Pet.”). The Petition is supported by the declaration testimony of Dr. Andrew Wolfe. Ex. 1002. Patent Owner filed a Preliminary Response. Paper 6 (“Prelim. Resp.”).

On October 12, 2017, ASUS Computer International, Inc. (“ASUS”) filed a Petition requesting *inter partes* review of claims 1–20 of the ’315 patent on the same grounds and arguments presented in Case IPR2017-02021 and requested joinder with Case IPR2017-02021. *See* Case IPR2018-00047, Papers 2, 3. Patent Owner filed a Preliminary Response. Case IPR2018-00047, Paper 7.

---

<sup>2</sup> Citations are to IPR2017-02021 unless otherwise indicated.

IPR2017-02021  
Patent 6,243,315 B1

On March 9, 2018, we instituted an *inter partes* review of the challenged claims in IPR2017-02021. Paper 7 (“Decision on Institution” or “Dec. on Inst.”). On March 20, 2018, we granted ASUS’s request for *inter partes* review and for joinder of the IPR2018-00047 proceeding with IPR2017-02021. IPR2018-00047, Paper 9. On June 1, 2018, Patent Owner filed a Patent Owner Response. Paper 10. On August 24, 2018, Petitioner filed a Reply. Paper 11 (“Reply”).

A hearing was held on November 16, 2018. A transcript of the hearing has been entered into the record. Paper 18 (“Tr.”).

### *B. Related Proceedings*

Petitioner identifies the following litigations as related proceedings: *Goodman v. Samsung Electronics America, Inc.*, Case No. 1:17-cv-05539 (S.D.N.Y.); *Goodman v. Hewlett-Packard Co.*, Case No. 4:16-cv-03195 (S.D. Tex.); *Goodman v. ASUS Computer Int’l, Inc.*, Case No. 4:16-cv-03232 (S.D. Tex.). Pet. 2.

Patent Owner further identifies the following litigations as related proceedings: *Goodman v. ASUS Computer Int’l*, Case No. 17-cv-05542 (N.D. Cal.) (transferred from the S.D. Tex.); *Goodman v. Lenovo (United States) Inc.*, Case No. 17-cv-06782; and *Goodman v. Acer American Corp.*, Case No. 17-cv-07297. See Prelim. Resp. 2; IPR2018-00047, Prelim. Resp. 3.

We also note that the ’315 patent was the subject of a Final Written Decision in *HP Inc. v. Goodman* (Case IPR2017-01994) in which we determined claims 1 and 5 were not shown to be unpatentable but that claims 10 and 16 were shown to be unpatentable. IPR2017-01994, Paper 16. The ’315 patent was also the subject of a petition for *inter partes* review in

*SMART Modular Technologies, Inc. v. Goodman*, Case IPR2015-01675, in which the Board instituted *inter partes* review and subsequently granted the parties' joint motion to terminate. *See* IPR2015-01675, Paper 20.

*C. The '315 patent*

The '315 patent is directed to memory systems having volatile solid state memory devices that retain information when an electrical power source is applied but lose their memory contents when power is removed. Ex. 1001, 2:54–58, 3:46–52. To reduce energy consumption and preserve memory contents, volatile memory devices are placed in low power “self-refresh mode” when the memory system is not receiving requests for access. *See id.* at 3:46–54 (stating the “low power mode utilizes significantly less electrical current than when the memory device is in the operating mode or powered up mode”), 3:25–30 (stating “placing the memory devices into a power down self-refresh mode . . . will maintain the data using a minimum of electrical power”). The memory system of the '315 patent has a control device interposed electrically between the memory devices and a central processing unit (“CPU”). *Id.* at 3:54–56. The control device senses CPU access of the memory devices and conditions the memory devices to an operating mode condition prior to allowing access to the information contained therein. *Id.* at 3:56–59. The control device also places the solid state memory devices into a low power standby mode when it “senses the termination of a memory cycle.” *Id.* at 3:59–62.

Figure 1 of the '315 patent, reproduced below, illustrates a preferred embodiment in which address and control busses are electrically isolated from the memory devices when the memory devices are in a power down self refresh mode. *Id.* at 5:60–63.

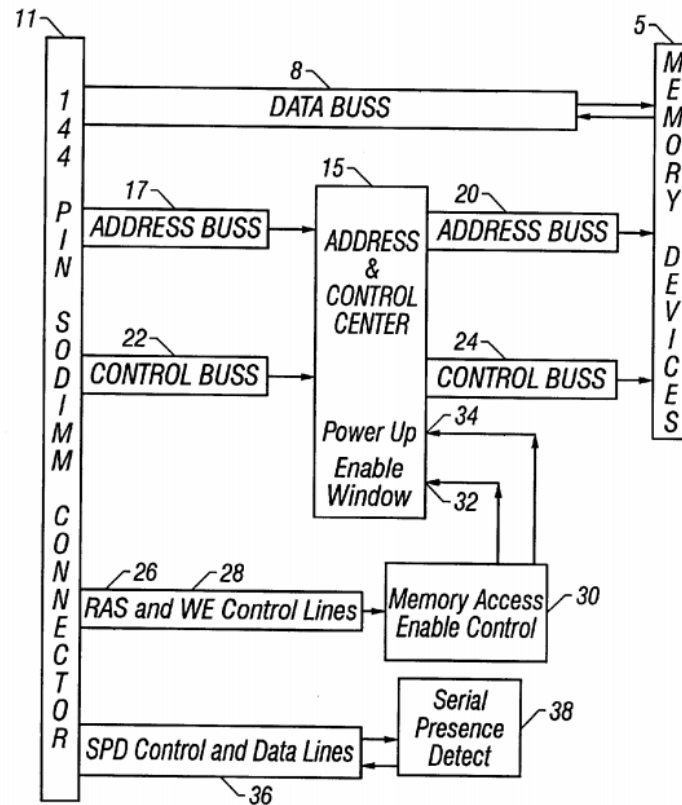

FIG. 1

As shown in Figure 1 of the '315 patent above, control device 15 is interdisposed between address buss 17 and address buss 20 (*id.* at 5:50–52) as well as in between control buss 22 and control buss 24 (*id.* at 5:54–56). Control devices 15 isolates address buss 17 and control buss 22 from memory devices 5 when the memory devices are in a power down self refresh mode. *Id.* at 5:60–63. By isolating the memory devices from control buss 22 and address buss 17, control device 15 prevents errant signals from erroneously changing or affecting the data being retained by memory devices 5. *Id.* at 5:63–67.

Figure 1 also shows row address select (“RAS”) control lines 26 and write enable (“WE”) control lines 28, which are connected to memory access enable control device 30. *Id.* at 6:1–3. Memory access enable control device 30 receives signals from the CPU indicating that a memory

# Explore Litigation Insights

Docket Alarm provides insights to develop a more informed litigation strategy and the peace of mind of knowing you're on top of things.

## Real-Time Litigation Alerts



Keep your litigation team up-to-date with **real-time alerts** and advanced team management tools built for the enterprise, all while greatly reducing PACER spend.

Our comprehensive service means we can handle Federal, State, and Administrative courts across the country.

## Advanced Docket Research



With over 230 million records, Docket Alarm's cloud-native docket research platform finds what other services can't. Coverage includes Federal, State, plus PTAB, TTAB, ITC and NLRB decisions, all in one place.

Identify arguments that have been successful in the past with full text, pinpoint searching. Link to case law cited within any court document via Fastcase.

## Analytics At Your Fingertips



Learn what happened the last time a particular judge, opposing counsel or company faced cases similar to yours.

Advanced out-of-the-box PTAB and TTAB analytics are always at your fingertips.

## API

Docket Alarm offers a powerful API (application programming interface) to developers that want to integrate case filings into their apps.

## LAW FIRMS

Build custom dashboards for your attorneys and clients with live data direct from the court.

Automate many repetitive legal tasks like conflict checks, document management, and marketing.

## FINANCIAL INSTITUTIONS

Litigation and bankruptcy checks for companies and debtors.

## E-DISCOVERY AND LEGAL VENDORS

Sync your system to PACER to automate legal marketing.