

IN THE UNITED STATES PATENT AND TRADEMARK OFFICE

Attorney Docket No. MCROP0102USH

Commissioner for Patents  
P.O. Box 1450  
Alexandria, VA 22313-1450

PATENT APPLICATION TRANSMITTAL

Transmitted herewith for filing is the patent application of:

Inventor(s): (names only, if known).	Bennett H. Adelson	
Title:	MACHINE OR GROUP OF MACHINES FOR MONITORING LOCATION OF A VEHICLE OR FREIGHT CARRIED BY A VEHICLE	
Customer No.	130163	

1. Papers Enclosed That Are Required for Filing Date under 37 CFR 1.53(b):

Specification including claims

Abstract

Drawing(s)

The enclosed drawing(s) are photograph(s), and there is also attached a "PETITION TO ACCEPT PHOTOGRAPH(S) AS DRAWING(S)." 37 C.F.R. 1.84(b).

2. Additional papers enclosed:

Preliminary Amendment

Information Disclosure Statement (37 CFR 1.98)

Form PTO-1449  Citations

Nonpublication Request

Power of Attorney

Application Data Sheet

3. Small Entity Status:  Applicant claims  Not claimed.  
small entity status.

4. Language:  English  Non-English

A verified/accurate translation is enclosed (37 CFR 1.52(d)).

5. Declaration or oath:     Enclosed                       Not enclosed.
- Enclosed is a copy of a declaration filed in prior application No. 14/661,774 of which this is a  continuation /  divisional. The accompanying continuation or divisional application is not believed to introduce any new matter.
6. Form of payment:
- No fee being paid at this time.
- Credit card payment via EFS web
- A check in the amount of \$\_\_\_\_\_ to cover the above fees is enclosed.
- Please charge our Deposit Account No. 18-0988 in the amount of \$\_\_\_\_\_.
- Fee for extra claims is not being paid at this time.
7. The Commissioner is hereby authorized to charge the following additional fees by this paper and during the entire pendency of this application to Account No. 18-0988:
- 37 CFR 1.16(a), (f) or (g) (filing fees)
- 37 CFR 1.16(b), (c) and (d) (presentation of extra claims)
- 37 CFR 1.17 (application processing fees)
- 37 CFR 1.16(e) (surcharge for filing the basic filing fee and/or declaration on a date later than the filing date of the application)
8. Credit any overpayment to Deposit Account No.18-0988.

Respectfully submitted,

Date: January 4, 2016

/Luis A. Carrion/

Luis A. Carrion, Reg. No. 61,255

RENNER, OTTO, BOISSELLE & SKLAR, LLP  
1621 Euclid Avenue, Nineteenth Floor  
Cleveland, Ohio 44115-2191  
Tel: 216-621-1113  
Fax: 216-621-6165

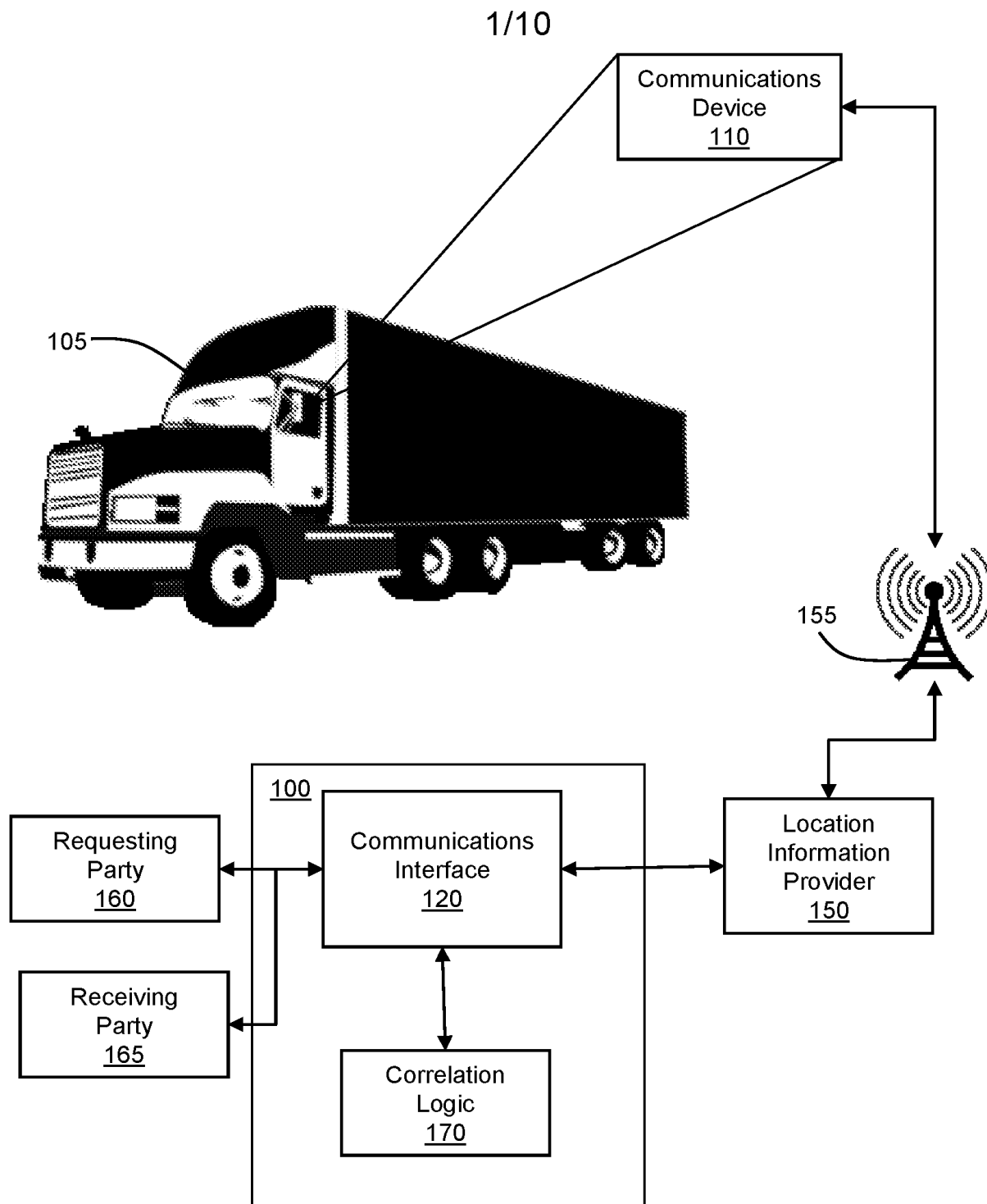

Figure 1

2/10

	<b>Active Driver <u>210a</u></b>	<b>Active Device <u>110a</u></b>	<b>Backup Driver <u>210b</u></b>	<b>Backup Device <u>110b</u></b>	<b>Total Capacity ft<sup>3</sup> / lbs.</b>	<b>Available Capacity ft<sup>3</sup> / lbs.</b>
105b	Gary Fisher	(546) 542-1235			3,931 42,010	2,531 22,010
105d	Colnago Cinelli	(563) 543-5635	Ross Raleigh	(243) 546-5435	2,878 <u>Ref</u> 36,280	2,878 <u>Ref.</u> 36,280
105f	Emilio Bozzi	(507) 543-5475	Murray Schwinn	(548) 243-5433	3,268 41,700	0 0

**Figure 2**



3/10

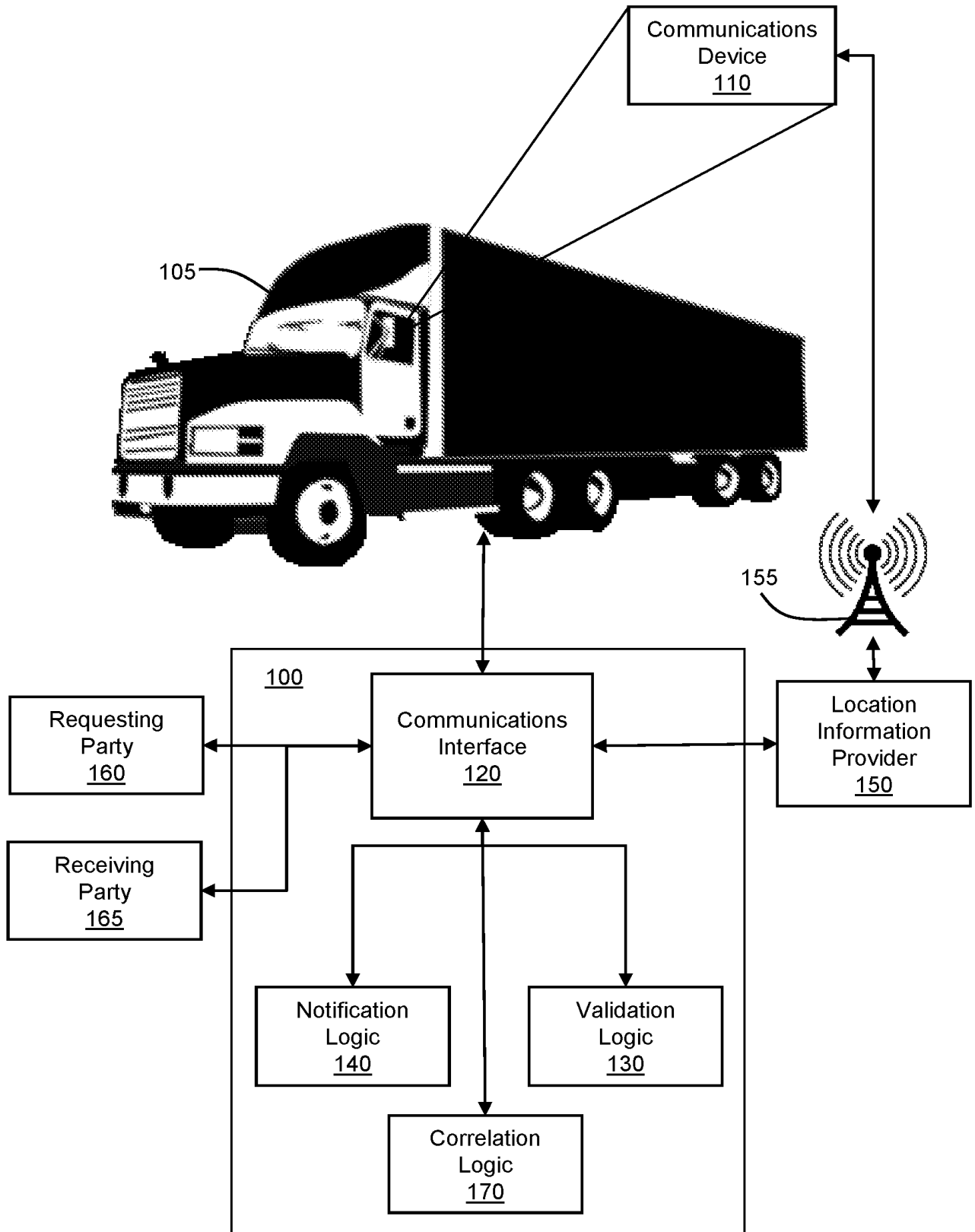

Figure 3

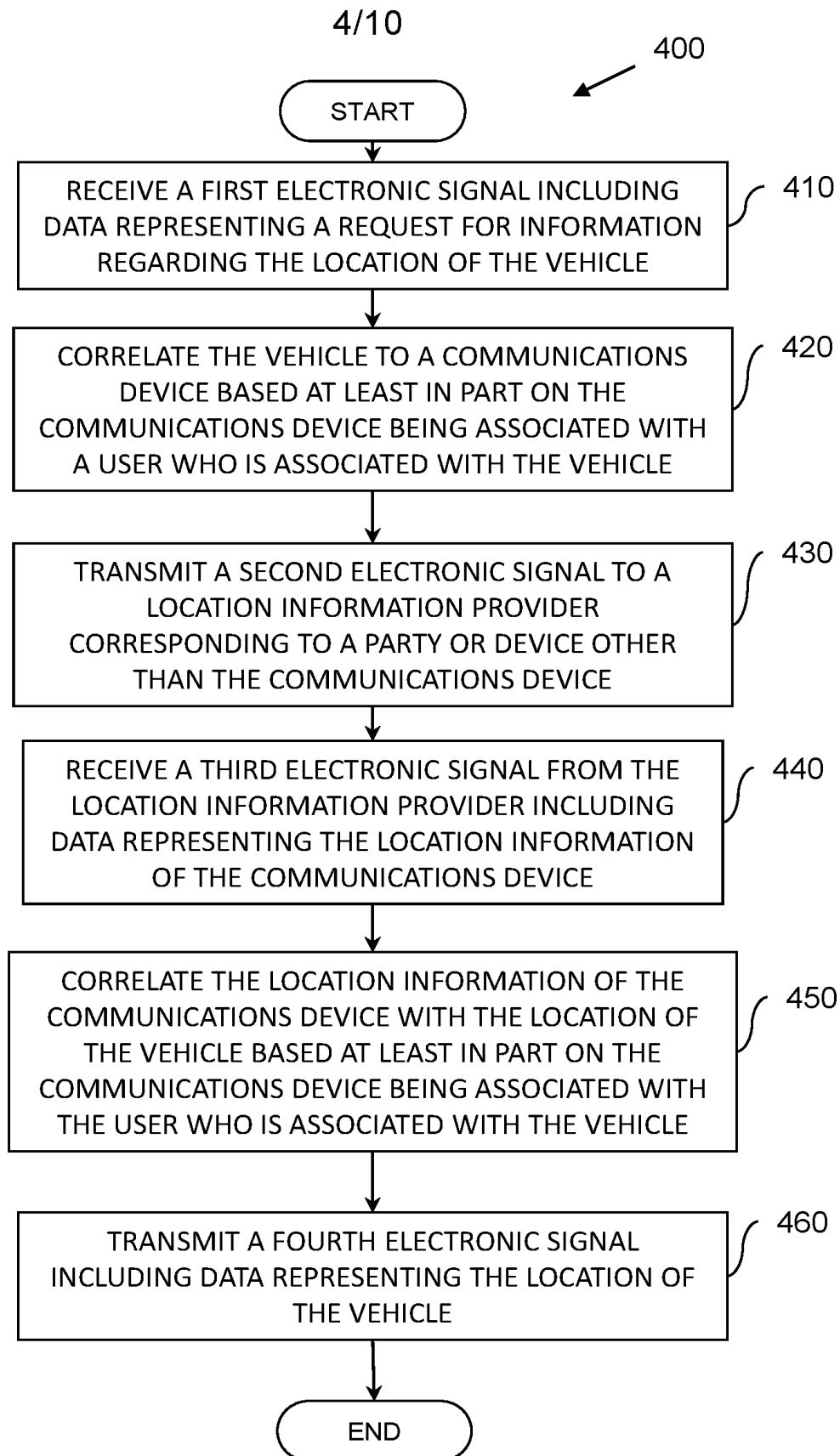

Figure 4

5/10

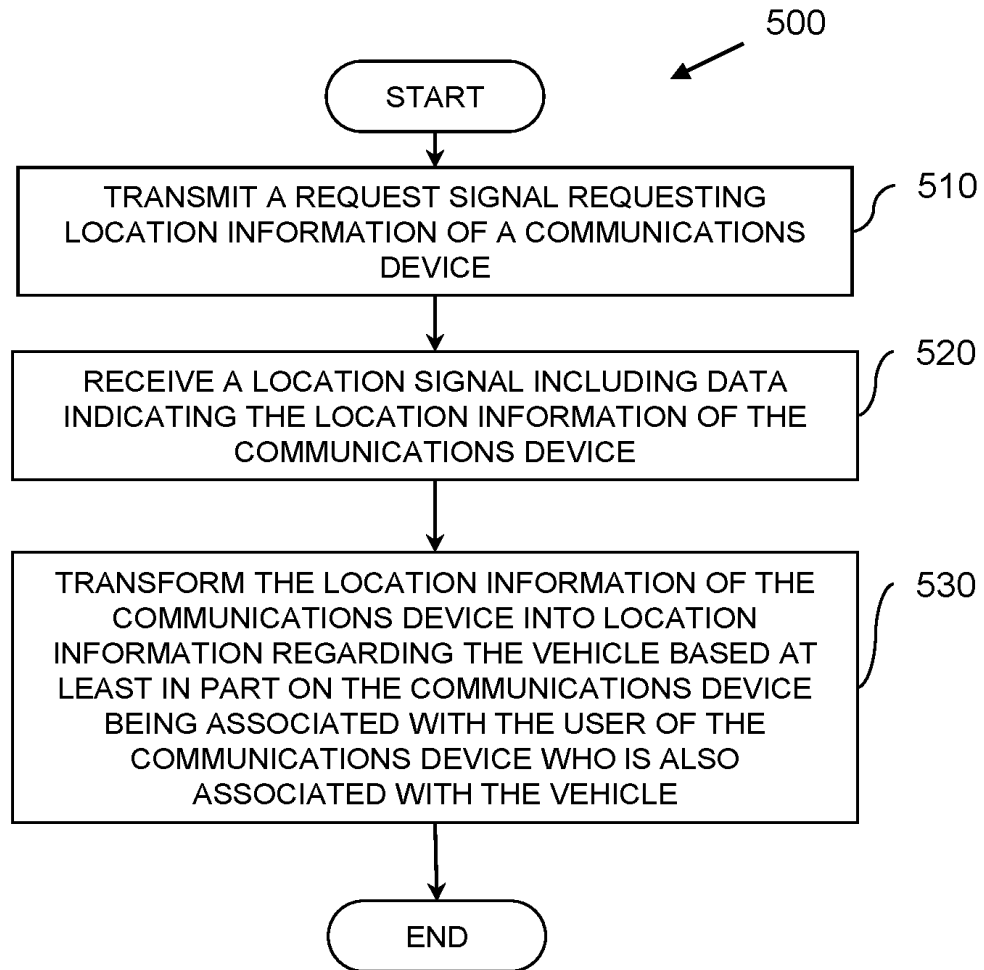

Figure 5

6/10

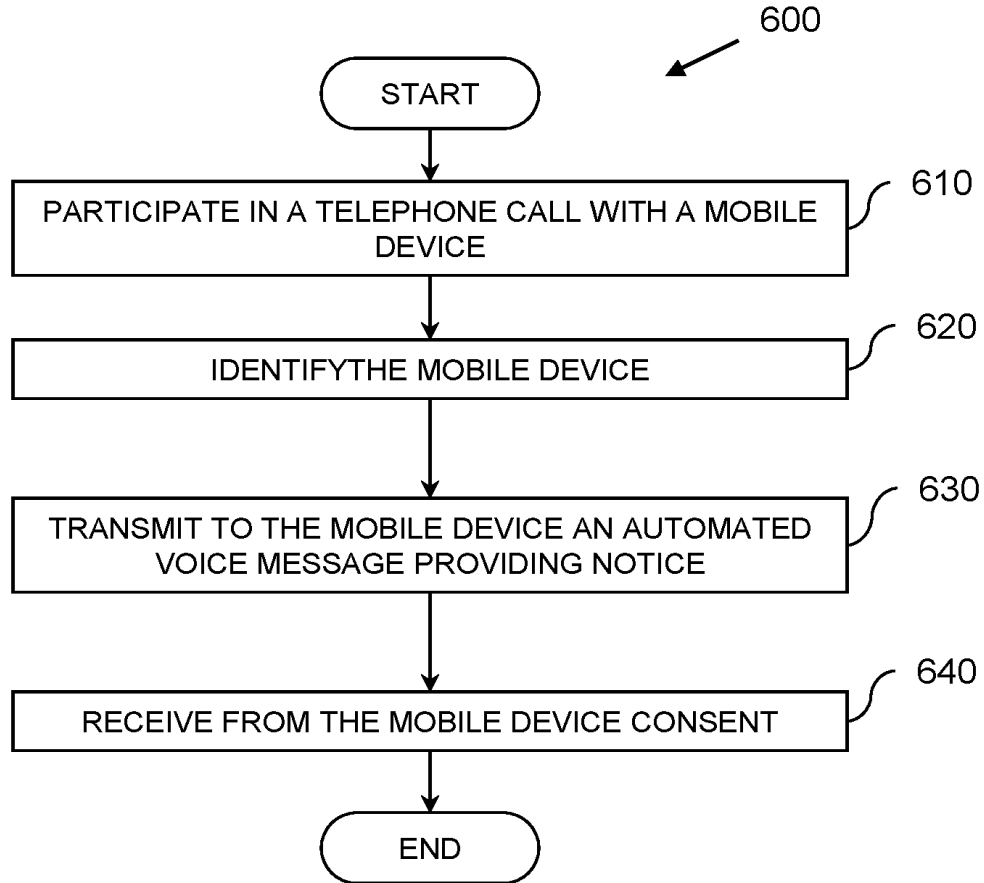

Figure 6

7/10

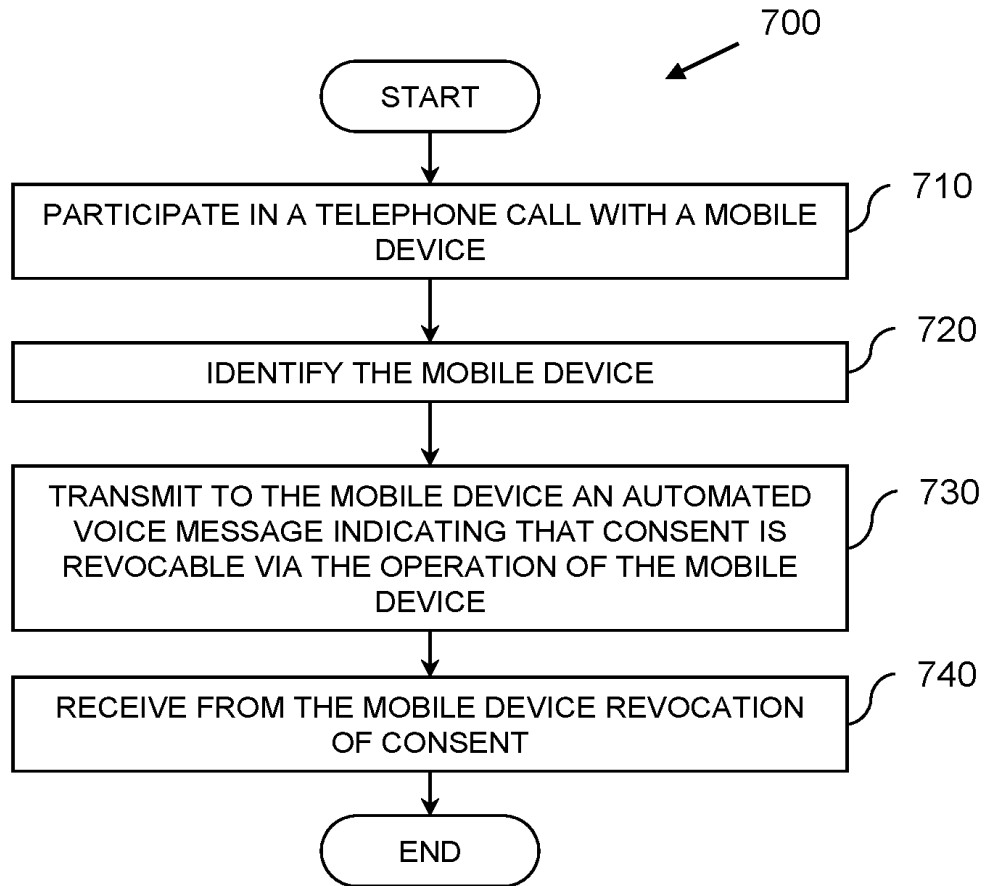

Figure 7

8/10

800

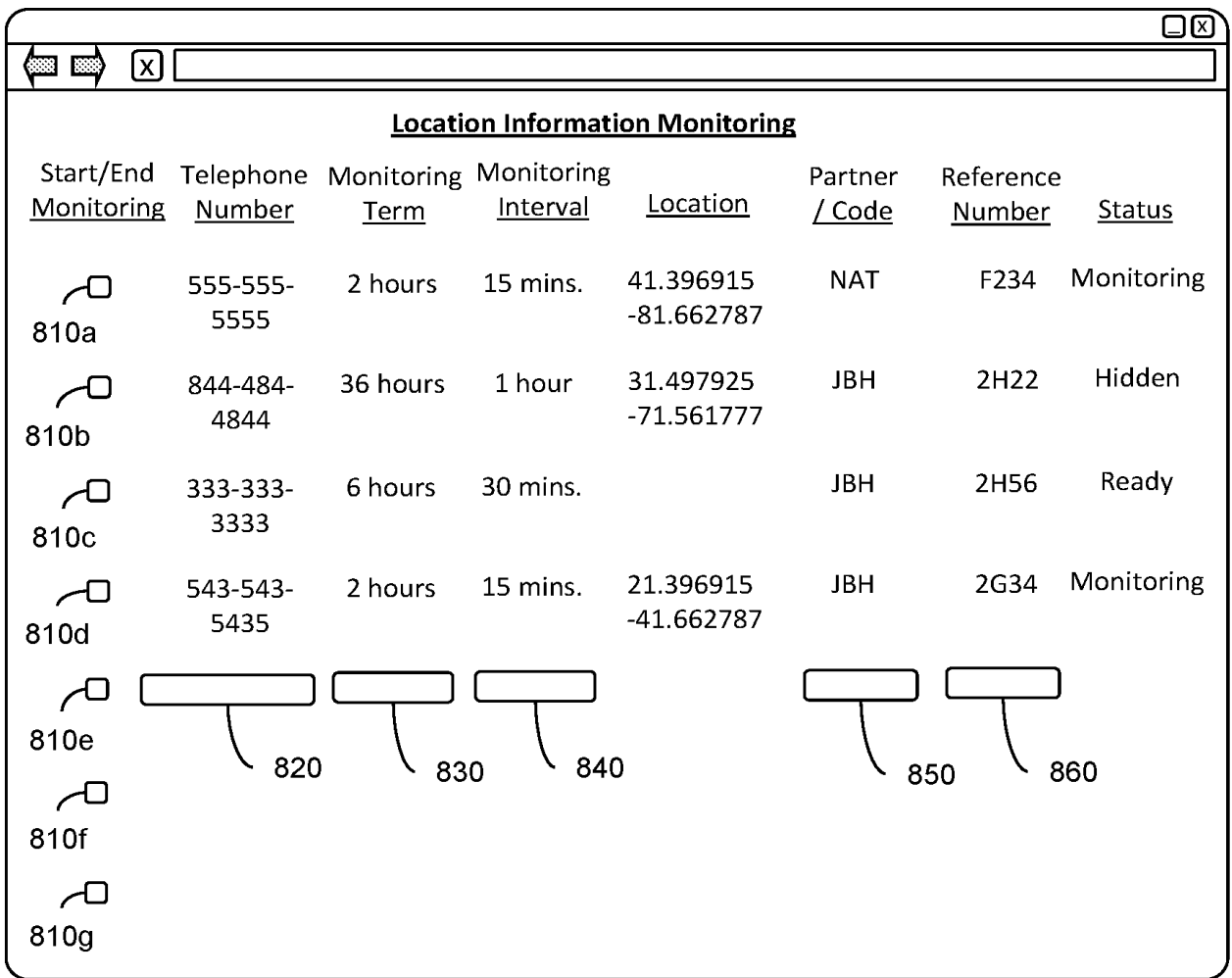
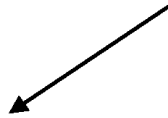

Figure 8

9/10

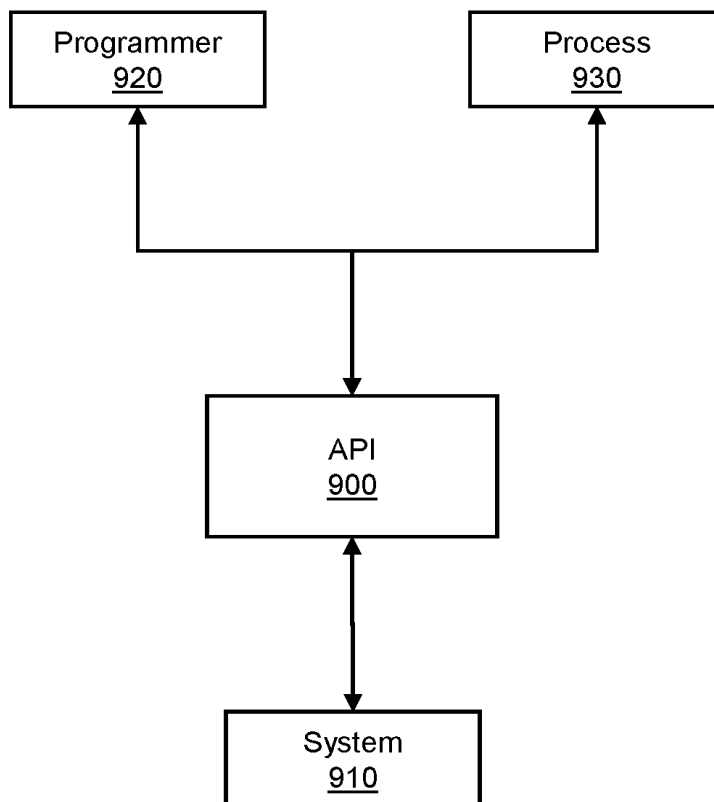

Figure 9

10/10

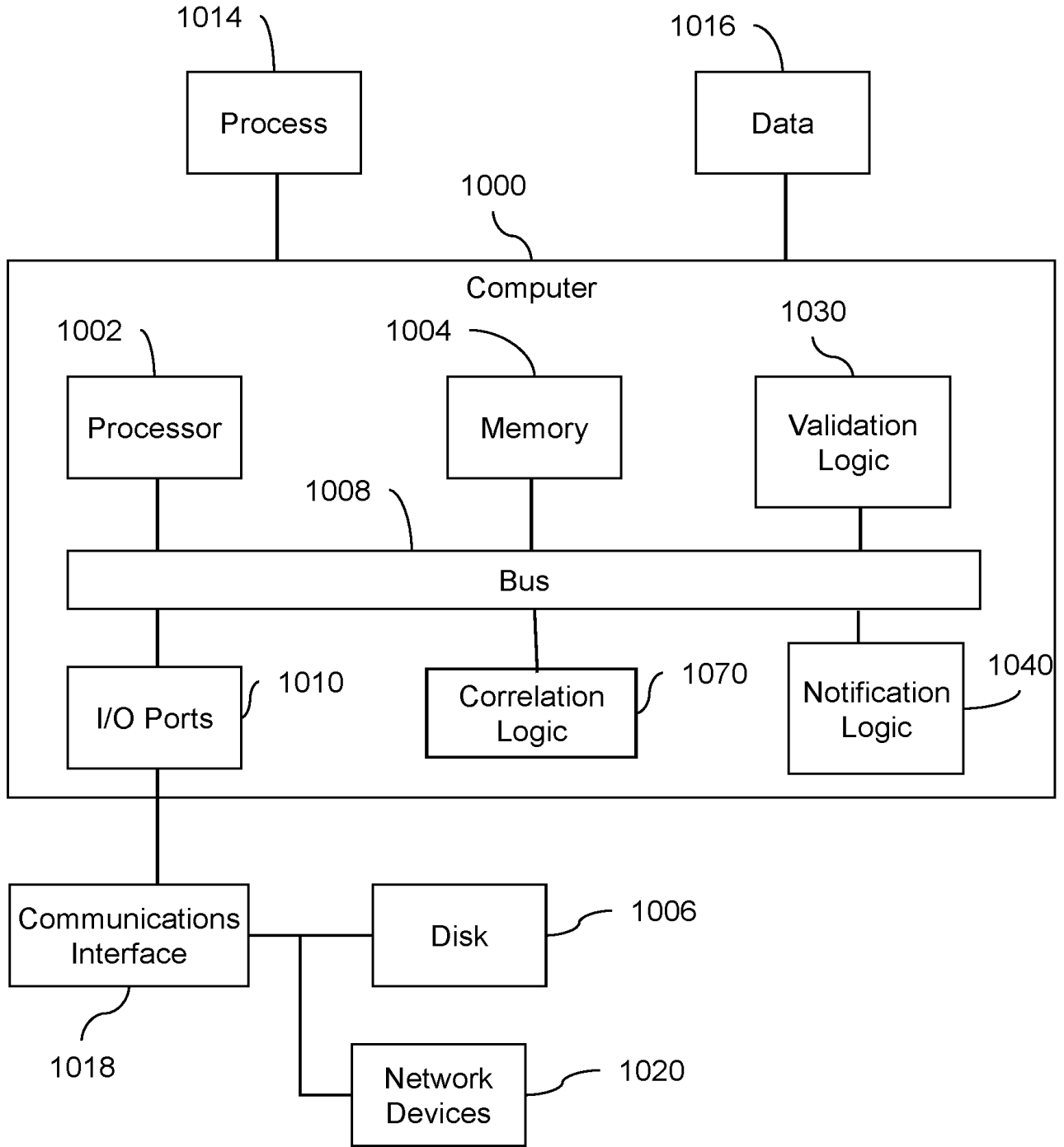

Figure 10



IN THE UNITED STATES PATENT AND TRADEMARK OFFICE

In re Patent Application of

Applicant: Bennett H. Adelson  
Application No.: Not Yet Assigned  
Filed: Herewith  
Title: MACHINE OR GROUP OF MACHINES FOR MONITORING LOCATION OF A VEHICLE  
OR FREIGHT CARRIED BY A VEHICLE  
Docket No. MCROP0102USH

INFORMATION DISCLOSURE STATEMENT

Commissioner for Patents  
P.O. Box 1450  
Alexandria, VA 22313-1450

Sir:

1. Pursuant to 37 C.F.R. 1.97 and 1.98, and in compliance with 37 C.F.R. 1.56, the Office's attention is directed to the patents, pending applications, publications and other information listed on the attached PTO-1449. A copy of each listed document is enclosed, except for (a) those previously cited or submitted to the Office in the following application(s) upon which this application relies for an earlier filing date under 35 U.S.C. 120, and (b) any U.S. patent or U.S. patent application publication if the present application was filed after June 30, 2003 or entered the national stage under 35 USC § 371 after June 30, 2003:

Serial No.:	<u>14/069,364</u>	<u>13/613,321</u>	<u>13/429,618</u>	<u>14/661,774</u>	<u>14/752,005</u>
Filing Date:	<u>10/31/2013</u>	<u>09/13/2012</u>	<u>03/26/2012</u>	<u>03/18/2015</u>	<u>06/26/2015</u>

Regarding any document, publication or other information for which a date is not given on the attached PTO-1449, Applicant(s) believe(s) the same may qualify as "prior" art to this application and should be treated accordingly, although Applicant(s) reserve(s) the right to contest the prior art status of any document, publication or information, should issue arise.

2. Regarding each listed document that is not in the English language, an English-language translation accompanies this Statement as indicated on the attached PTO-1449 or a concise explanation of the relevance of the document is set forth in the following document(s):
- (a) \_\_\_ A copy of each English language version of a search report (or EPO Search Report) indicating the degree of relevance found by the foreign office of each document being submitted from the search report, is being submitted herewith or has previously been submitted.
  - (b) \_\_\_ Attached is a "Concise Explanation of Relevance of Non-English Language Documents".
3. Pursuant to 37 C.F.R. 1.97(b) this Statement is being filed (one must be checked):
- (a) X Within 3 months of the filing date or date of entry into the National Stage, or the filing date of a Request for Continued Examination (RCE).
  - (b) \_\_\_ Before the mailing date of a first Office Action on the merits. If this Statement is not filed before the mailing date of a first Office Action on the merits, the required certification is given below or, in the absence thereof, the Office is authorized to charge the required fee set forth in 37 C.F.R. 1.17(p) to Deposit Account No. 18-0988 for consideration of this Statement.
  - (c) \_\_\_ Before the mailing date of a first Office Action on the merits after a first or second submission after final rejection under 37 C.F.R. 1.129(a).

- (d) \_\_\_ After the period set forth in 37 C.F.R. 1.97(b) but before the mailing date of either a final action or a notice of allowance.
- (1) \_\_\_ The required certification is given below, or
- (2) \_\_\_ Enclosed is a credit card payment covering the fee set forth in 37 C.F.R. 1.17(p) for consideration of this Statement, or
- (3) \_\_\_ Charge the fee set forth in 37 C.F.R. 1.17(p) to Deposit Account No. 18-0988
- (e) \_\_\_ After the mailing date of either a final action or a notice of allowance, but before payment of the issue fee. Petition hereby is made for consideration of this Statement and the required certification is indicated below.
- (1) \_\_\_ Enclosed is a credit card payment covering the fee set forth in 37 C.F.R. 1.17(p), or
- (2) \_\_\_ Charge the fee set forth in 37 C.F.R. 1.17(p) to Deposit Account No. 18-0988.

4. Certification (if applicable)

- (a) \_\_\_ The undersigned hereby certifies that each item of information contained in this Statement was first cited in any communication from a foreign patent office in a counterpart foreign application not more than 3 months prior to the filing of this Statement.
- (b) \_\_\_ The undersigned hereby certifies that no item of information contained in this Statement was cited in a communication from a foreign patent office in a counterpart foreign application, and, to the undersigned's knowledge after making reasonable inquiry, no item of information contained in this statement was known to any individual designated in 37 C.F.R. 1.56(c) more than 3 months prior to the filing of this Statement.

5. The Commissioner is hereby authorized to charge any additional fees or credit any overpayment to Deposit Account No. 18-0988.

Respectfully submitted,

RENNER, OTTO, BOISSELLE & SKLAR, LLP

/Luis A. Carrion/

By \_\_\_\_\_  
Luis A. Carrion, Reg. No. 61,255

1621 Euclid Avenue, 19th Floor  
Cleveland, Ohio 44115  
(216) 621-1113

M:\MIMCRO\IP0102USG\IP0102USG-IDS.doc

Form PTO-1449 (Modified)  <b>LIST OF PATENTS AND PUBLICATIONS FOR APPLICANT'S INFORMATION DISCLOSURE STATEMENT</b>  (Use several sheets if necessary)	Atty Docket No.: <b>MCROP0102USH</b>	Serial No.: <b>Not Yet Assigned</b>
	Applicant: <b>Bennett H. Adelson</b>	
	Filing Date: <b>Herewith</b>	Group: <b>Unknown</b>

**U.S. PATENT DOCUMENTS**

Examiner Initial	Document Number	Date (MM/YYYY)	Name	Class	Sub-class	Filing Date if Appropriate
	6,442,391	08/2002	Johansson et al.			
	5,794,174	08/1998	Janky et al.			
	5,774,876	06/1998	Woolley et al.			
	2008/0132252	06/2008	Altman et al.			
	2011/0001638	01/2011	Pudar			
	2011/0063138	03/2011	Berkobin et al.			
	2010/0228404	09/2010	Link et al.			
	2006/0187027	08/2006	Smith			
	7,366,522	04/2008	Thomas			
	8,301,158	10/2012	Thomas			
	8,369,867	02/2013	Van Os et al.			
	8,649,775	02/2014	Alessio et al.			
	8,718,672	05/2014	Xie et al.			
	8,755,823	06/2014	Proietti et al.			
	2009/0017803	01/2009	Brillhart et al.			
	2009/0030770	01/2009	Hersh et al.			
	2009/0143079	06/2009	Klassen et al.			
	2012/0265433	10/2012	Viola et al.			

**FOREIGN PATENT DOCUMENTS**

Examiner Initial	Document Number	Date (MM/YYYY)	Country	Class	Sub-class	Translation	
						Yes	No

**OTHER ART**

Examiner Initial	Author, Title, Source, Date, Pertinent Pages, etc.
	Non-final Office Action of corresponding U.S. Patent Application No. 13/409,281, dated 2012-05-15
	Notice of Allowance of corresponding U.S. Patent Application No. 13/409,281, dated 2012-06-28
	Non-final Office Action of corresponding U.S. Patent Application No. 13/613,321, dated 2013-01-31
	Final Office Action of corresponding U.S. Patent Application No. 13/613,321, dated 2013-07-01
	Notice of Allowance of corresponding U.S. Patent Application No. 13/613,321, dated 2013-10-04
	Non-final Office Action of corresponding U.S. Patent Application No. 14/069,364, dated 2015-02-12
	Notice of Allowance of corresponding U.S. Patent Application No. 13/429,618, dated 2012-03-26
	Notice of Allowance of corresponding U.S. Patent Application No. 14/661,774, dated 2015-05-27
	HURCOM, STEPHEN; "Tracking to Keep Trucking", <a href="http://www.mapinfo.com">www.mapinfo.com</a> ; June 27, 2003
	BRITTON, DIANA; "A Mobile Industry: Cell Phones Useful to Stay Connected With Drivers", <a href="http://www.truckinginfo.com">www.truckinginfo.com</a> ; October 2009
	Non-final Office Action of corresponding U.S. Patent Application No. 14/752,0051, dated 2015-12-03

EXAMINER	DATE CONSIDERED
----------	-----------------

EXAMINER: Initial if reference considered, whether or not citation is in conformance with MPEP 609; Draw line through citation if not in conformance and not considered. Include copy of this form with next communication to applicant.

**Information Disclosure Statement PTO-1449 (Modified)**

The identification of any reference is not intended to be, and should not be understood as being, an admission that such publication, in fact, constitutes "prior art" within the meaning of applicable law since, for example, a given reference may have a later effective date than first seems apparent or the reference may have an effective date which can be antedated. The "prior art" status of any reference is a matter to be resolved during prosecution.

MACHINE OR GROUP OF MACHINES FOR MONITORING LOCATION OF A VEHICLE OR  
FREIGHT CARRIED BY A VEHICLE

TECHNICAL FIELD

**[0001]** The present disclosure relates to a machine or group of machines for monitoring location.

BACKGROUND

**[0002]** Location information is becoming more important and prevalent.

**[0003]** In one example application of the use of location information, carriers, shippers, freight hauling services providers, third-party logistics service providers and courier services providers as well as other logistics and freight service providers (freight hauling) benefit from monitoring the location of vehicles in their fleets or under contract. Monitoring the location of vehicles helps improve efficiency because it allows for real-time or near real-time decision making when matching loads with vehicles. For example, by monitoring the location of fleet vehicles, a dispatcher may better understand which vehicle is the most appropriate (e.g., geographically closest, appropriate size, etc.) to send to a location for a load pickup. Conventional systems for monitoring vehicle location have relied on global positioning systems (GPS) to provide the vehicle's location. These systems require a GPS receiver to be installed in each vehicle. Moreover, some of these systems require the installation of additional dedicated equipment in each vehicle.

**[0004]** In addition, at least in part due to limitations of conventional systems for monitoring vehicle location, a common practice in the vehicle location monitoring services industry is to charge a user a standard flat monthly fee for monitoring services. This practice may represent a substantial cost to a user or organization that, for example, may wish to monitor a relatively small number of vehicles or a relatively small number of loads for a relatively short amount of time.

SUMMARY

**[0005]** Alternative methods for monitoring location of vehicles include radiolocation

techniques including triangulation or multilateration methods that are capable of locating devices in a network. These methods involve the measurement of radio signals between a device and radio towers in the network. The technology, originally intended by telecommunication companies to approximate the location of a mobile phone in case of emergencies, provides the location of a device in the network.

**[0006]** The use of all of these location information technologies also raises privacy issues. A user's privacy may be at risk if location information is misused or disclosed without the authorization or knowledge of the user. To address these privacy concerns, various governmental and business organizations have developed rules and guidelines to protect user privacy. For example, the International Association for the Wireless Telecommunications Industry (CTIA) has developed Best Practices and Guidelines for Location-Based Services (the "CTIA Guidelines"), which are hereby incorporated by reference.

**[0007]** The Guidelines provide a framework based on two principles: user notice and consent. Users must receive "meaningful notice about how location information will be used, disclosed and protected so that users can make informed decisions... and... have control over their location information." Users must also "consent to the use or disclosure of location information" and "have the right to revoke consent... at any time."

**[0008]** Although, electronic methods have been developed that make use of web browsers and SMS texting capabilities of mobile devices to provide notification and consent, some of these systems have proved inconvenient and may require advanced mobile devices or extensive user training.

**[0009]** A computer implemented method for monitoring location of a vehicle includes receiving a first electronic signal including data representing a request for information regarding the location of the vehicle, correlating the vehicle to a communications device based at least in part on the communications device being associated with a user who is associated with the vehicle, and transmitting a second electronic signal to a location information provider corresponding to a party or device other than the communications device. The second electronic signal includes data representing a request for location information of the communications device. The computer implemented method for

monitoring location of a vehicle further includes receiving a third electronic signal from the location information provider. The third electronic signal includes data representing the location information of the communications device. The computer implemented method for monitoring location of a vehicle further includes correlating the location information of the communications device with the location of the vehicle based at least in part on the communications device being associated with the user who is associated with the vehicle, and transmitting a fourth electronic signal including data representing the location of the vehicle.

**[0010]** Another computer implemented method for monitoring location of a vehicle includes transmitting a request signal requesting location information of a communications device. The request signal is transmitted to a party other than the communications device and the communications device is associated with a user of the communications device who is associated with the vehicle. The computer implemented method for monitoring location of a vehicle further includes receiving a location signal including data indicating the location information of the communications device. The location signal is received from a party other than the communications device and the location information of the communications device is originally obtained using a method not requiring a global position system (GPS) satellite receiver to form part of the communications device. The computer implemented method for monitoring location of a vehicle further includes transforming the location information of the communications device into location information regarding the vehicle based at least in part on the communications device being associated with the user of the communications device who is associated with the vehicle.

**[0011]** A system for monitoring location of a vehicle includes a communications interface configured to communicate electronic signals including: a first electronic signal including data representing a request for the location of the vehicle, the first electronic signal received from a requesting party, a second electronic signal including data representing a request for location information of a communications device, wherein the second electronic signal is transmitted to a location information provider corresponding to a party or device other than the communications device, wherein the communications device is associated with a user of the communications device who is associated with the vehicle, a

third electronic signal including data representing the location information of the communications device, wherein the third electronic signal is received from the location information provider corresponding to the party or device other than the communications device, and a fourth electronic signal including data representing the location of the vehicle, the fourth electronic signal transmitted to a receiving party. The system for monitoring location of a vehicle further includes a correlation logic configured to correlate the location information of the communications device to the location of the vehicle based at least in part on the communications device being associated with the user of the communications device who is associated with the vehicle.

#### BRIEF DESCRIPTION OF THE DRAWINGS

**[0012]** The accompanying drawings, which are incorporated in and constitute a part of the specification, illustrate various example systems, methods, and so on, that illustrate various example embodiments of aspects of the invention. It will be appreciated that the illustrated element boundaries (e.g., boxes, groups of boxes, or other shapes) in the figures represent one example of the boundaries. One of ordinary skill in the art will appreciate that one element may be designed as multiple elements or that multiple elements may be designed as one element. An element shown as an internal component of another element may be implemented as an external component and vice versa. Furthermore, elements may not be drawn to scale.

**[0013]** **Figure 1** illustrates an exemplary system for monitoring the location of a vehicle.

**[0014]** **Figure 2** illustrates a simplified exemplary chart illustrating how a correlation logic may correlate a vehicle to a communications device or the location of the vehicle to the location information of the communications device.

**[0015]** **Figure 3** illustrates the exemplary system for monitoring the location of a vehicle with additional details.

**[0016]** **Figure 4** illustrates a flow diagram for an exemplary method for monitoring location of a vehicle.

**[0017]** **Figure 5** illustrates a flow diagram for an exemplary method for monitoring location of a vehicle.



**[0018]** **Figure 6** illustrates a flow diagram for an exemplary method for receiving consent from a user to monitoring the location of a vehicle associated with the user.

**[0019]** **Figure 7** illustrates a flow diagram for an exemplary method for receiving from a user a revocation of consent to monitoring the location of a vehicle associated with the user.

**[0020]** **Figure 8** illustrates an exemplary user interface for use in conjunction with a system for monitoring the location of a vehicle.

**[0021]** **Figure 9** illustrates an application programming interface (API) providing access to a system for monitoring the location of a vehicle.

**[0022]** **Figure 10** illustrates a computer where systems or methods for monitoring the location of a vehicle may be implemented.

#### DETAILED DESCRIPTION

**[0023]** Some portions of the detailed descriptions that follow are presented in terms of algorithms and symbolic representations of operations on data bits within a memory. These algorithmic descriptions and representations are the means used by those skilled in the art to convey the substance of their work to others. An algorithm is here, and generally, conceived to be a sequence of operations that produce a result. The operations may include physical manipulations of physical quantities. Usually, though not necessarily, the physical quantities take the form of electrical or magnetic signals capable of being stored, transferred, combined, compared, and otherwise manipulated in a logic and the like.

**[0024]** It has proven convenient at times, principally for reasons of common usage, to refer to these signals as bits, values, elements, symbols, characters, terms, numbers, or the like. It should be borne in mind, however, that these and similar terms are to be associated with the appropriate physical quantities and are merely convenient labels applied to these quantities. Unless specifically stated otherwise, it is appreciated that throughout the description, terms like processing, computing, calculating, determining, displaying, or the like, refer to actions and processes of a computer system, logic, processor, or similar electronic device that manipulates and transforms data represented as physical (electronic) quantities.

**[0025]** In the present disclosure, embodiments are described in the context of location of freight hauling vehicles. It will be appreciated, however, that the exemplary context of freight hauling vehicles is not the only operational environment in which aspects of the disclosed systems and methods may be used. Therefore, the techniques described in this disclosure may be applied to many types of apparatus, vehicles or devices whose location information may be of interest.

**[0026]** **Figure 1** illustrates an exemplary system 100 for monitoring the location of a vehicle 105, which has a communication device 110 within the vehicle 105. The system 100 includes a communications interface 120 that communicates with devices external to the system 100 via electronic signals. For example, the communications logic 120 is configured to communicate with a location information provider 150, a requesting party 160, and a receiving party 165.

**[0027]** The location information provider 150 corresponds to a party or device other than the vehicle 105 and the device 110. The location information provider 150 has access to location of the vehicle 105 or the device 110. In one embodiment, the location information provider 150 is a wireless service provider that provides wireless service in a network 155. In another embodiment, the location information provider 150 is a third party or device that receives the location information of the device 110 from the wireless service provider or from some other party or device. In yet another embodiment, the location information provider 150 is a party other than a wireless service provider or a third party. For example, the party seeking to monitor the location of the vehicle 105, the requesting party 160, may have access to the location information of the device 110. In that case, the requesting party 160 may also be the location information provider 150. In another example, the party operating the system 100 may have access to the location information of the device 110.

**[0028]** The requesting party 160 corresponds to a party or device interested in monitoring the location of the vehicle 105 or on allowing another party to monitor the location of the vehicle 105. The receiving party 165 corresponds to a party or device who receives the location of the vehicle 105 from the system 100 to monitor the location of the vehicle 105. In an example involving freight hauling services providers or freight carriers, a

carrier who is interested in monitoring the location of its own vehicles, vehicles under contract, or other vehicles requests the ability to monitor the location of the vehicle 105 for its own consumption. In this case, the carrier is both the requesting party 160 and the receiving party 165. In another example, the requesting party 160 may be a driver interested in sharing the location of his/her vehicle 105 with a carrier to allow the carrier to monitor the location of the vehicle 105. In this case, the driver is the requesting party 160 and the carrier is the receiving party 165. In one embodiment, multiple parties or devices may be interested in monitoring the location of the vehicle 105 or on allowing another party to monitor the location of the vehicle 105. In that case, the communications interface 120 is configured to communicate with multiple requesting parties and/or multiple receiving parties.

**[0029]** The system 100 further includes a correlation logic 170 that correlates the vehicle 105 and the device 110. In one embodiment, the correlation logic 170 correlates the vehicle 105 and the device 110 based at least in part on the vehicle 105 being associated with at least one user who is also associated with the device 110. For example, the user may be associated with the vehicle 105 because the user is the designated driver of the vehicle 105 and the user may be associated with the communications device 110 because the user is under contract with a wireless service provider for the provider to provide wireless service to the communications device 110. In another example, the user is associated with the vehicle 105, with the device 110, or with both in a database or in the correlation logic 170. In another embodiment, the vehicle 105 is directly associated with the communications device 110 without a user being associated with the vehicle 105 or with the device 110.

**[0030]** In an example of the operation of the system 100, the requesting party 160 transmits and the communications interface 120 receives data representing a request from the requesting party 160 for the ability to monitor the location of the vehicle 105. In response to the request from the requesting party 160, the correlation logic 170 correlates the vehicle 105 to the device 110. The communications interface 120 transmits to the location information provider 150 data representing one or more requests for location information of the device 110. In response to a request for location information of the device 110, the location information provider 150 transmits and the communications

interface 120 receives data representing the location information of the device 110. The correlation logic 170 correlates the location information of the device 110 to the location of the vehicle 105.

**[0031]** With the location of the vehicle 105 on hand, the communication interface 120 can transmit data representing the location of the vehicle 105 to the receiving party 165 through computer communication. The location of the vehicle 105 may then be displayed in a user interface (not shown). In another embodiment, the communications interface 120 is configured to communicate the location to the receiving party 165 by exposing an application programming interface (API) through which the receiving party 165 can access the location of the vehicle 105. The receiving party 165 can make use of the API to make the information available to its enterprise software (e.g., SAP, Oracle, etc.) for example.

**[0032]** **Figure 2** illustrates a simplified exemplary chart 200 illustrating how the correlation logic 170 may correlate the vehicle 105 to the device 110 or the location of the vehicle 105 to the location information of the device 110. In the illustrated embodiment, for each vehicle 105a-g registered in the system 100, the correlation logic 170 has data fields corresponding to each vehicle 105a-g. The data fields include information regarding the vehicles 105a-g. Potential information that may be included in the data fields include one or more drivers 210a-b associated with each of the vehicles 105a-g and one or more devices 110a-b associated with each of the drivers 210a-b, respectively. The drivers 210a-b are identified by name while the devices 110a-b are identified by an identifier, which in this case corresponds to a telephone number associated with the respective device 110a-b.

**[0033]** In other embodiments, the identifier corresponds to a number or some other identifying information associated with the device 110 other than a telephone number. For example, the identifier may be a mobile identification number (MIN), an electronic serial number (ESN), an International Mobile Equipment Identity (IMEI), an International Mobile Subscriber Identity (IMSI), a Mobile Equipment Identifier (MEID), a Manufacturer's Serial Number (MSN), a Mobile Subscriber Integrated Services Digital Network (MSISDN) number, a Media Access Control (MAC) address, combinations thereof, and so on.

**[0034]** Additional information that may be included in the data fields include the capacity of a vehicle 105a-g (e.g., total volumetric and weight capacity 220, available

volumetric and weight capacity 230, etc.), whether the container is refrigerated Ref., and so on.

**[0035]** In the illustrated embodiment, the vehicle 105a is associated with an active driver 210a named Bianchi Campagnolo who is associated with an active device 110a identified by an identifier corresponding to the telephone number (143) 846-5405. The vehicle 105a may also be associated with a backup driver named Bob Haro who is associated with a backup device 110b identified by an identifier corresponding to the telephone number (443) 240-5465. The correlation logic 170 correlates the vehicle 105 with the active driver 210a unless the correlation logic 170 is instructed to instead use the backup driver 210b. In that case, the active driver 210a and the backup driver 210b may switch, with the name listed under backup driver 210b appearing under active driver 210a and viceversa. Similarly, the correlation logic 170 correlates the vehicle 105 with the active device 110a unless the correlation logic 170 is instructed to instead use the backup device 110b. In that case, the active device 110a and the backup device 110b may switch, with the identifier listed under backup device 110b appearing under active device 110a and viceversa. In this way, the correlation logic 170 can transform the location information of the communications device 110 into information regarding the location of the vehicle 105 by correlating the location information of the communications device 110 to the location of the vehicle 105 based at least in part on the communications device 110 being associated with the user who is associated with the vehicle 105. In one embodiment, the correlation logic 170 correlates the vehicle 105 with the active driver 210a and the backup driver 210b.

**[0036]** In the illustrated embodiment, the vehicle 105a has a total capacity of 4,013 pounds and 42,660 cubic feet of which 4,013 pounds and 42,660 cubic feet are currently available. The vehicle 105c has a total capacity of 2,878 pounds and 36,280 cubic feet. The capacity of the vehicle 105c is refrigerated capacity. However, none of that capacity is currently available (e.g., the container associated with the vehicle 105c is full) since the available capacity is indicated as 0 pounds and 0 cubic feet.

**[0037]** **Figure 3** illustrates the exemplary system 100 for monitoring the location of a vehicle 105 with additional details.

**[0038]** As described above, the system 100 receives the location information of the

device 110 from a location information provider 150, which is a party or device other than the device 110. The location information provider 150 may be a wireless service provider or a party or device that receives the location information from a wireless service provider. Examples of wireless service providers in the United States include Verizon Wireless, AT&T Mobility, Sprint Nextel, T-Mobile, etc. These wireless service providers have technologies deployed that allow them to approximate the location of devices in their network. Some of these technologies were developed and deployed in compliance with E911, a government mandate requiring the wireless service providers to provide the approximate location of a mobile device in case of an emergency.

**[0039]** Location of devices in a cellular network may be described as involving two general positioning techniques: 1) techniques that require the device to incorporate a global positioning system (GPS) receiver, and 2) techniques that use some form of radiolocation from the device's network and do not require the device to incorporate a GPS receiver.

**[0040]** In one embodiment, the wireless service provider or another party or device originally obtaining or deriving the location information of the device 110 derives the location information of the device 110 at least in part by using a radiolocation technique where the approximated location of the device 110 corresponds to a range of locations corresponding to a transmission range of a single radio tower 155. In an example of this technology, each radio tower is assigned a unique identification number, a Cell-ID. The Cell-ID is received by all mobile devices in the coverage area of the radio tower 155, thus the position of the device 110 in the coverage area of the radio tower 155 is derived from the coordinates of the radio tower 155. Additional techniques, such as measuring signal strength of the device 110 could be used to increase the accuracy of the location information. Accuracy can be further enhanced by including a measurement of Timing Advance (TA) in GSM/GPRS networks or Round Trip Time (RTT) in UMTS networks. TA and RTT use time offset information sent from the radio tower 155 to adjust the communications device's relative transmit time to correctly align the time at which the communications device's signal arrives at the radio tower 155. These measurements can be used to determine the distance from the communications device to the radio tower 155, further improving accuracy.

**[0041]** In one embodiment, the wireless service provider or another party or device originally obtaining or deriving the location information of the device 110 derives the location information of the device 110 at least in part using triangulation between multiple radio towers such as tower 155. The location of the device 110 may be determined by using one or a combination of several techniques including the following:

**[0042]** Angle of Arrival (AOA) – This technique requires at least two radio towers and locates the device 110 at the point where the lines along the angles from each tower intersect.

**[0043]** Time Difference of Arrival (TDOA) – This technique also requires at least two radio towers and determines the time difference between the time of arrival of a signal from the device 110 to the first tower 155, to a second tower, and so on.

**[0044]** Advanced Forward Link Trilateration (AFLT) – In this technique the communications device measures signals from nearby towers such as radio tower 155, which are then used to triangulate an approximate location of the device 110.

**[0045]** Enhanced-observed time difference (E-OTD) – This technique takes data received from the nearby towers such as radio tower 155 to measure the difference in time it takes for the data to reach the device 110. The time difference is used to calculate where the device 110 is in relation to the radio towers.

**[0046]** In one embodiment, the wireless service provider or another party or device originally obtaining or deriving the location information of the device 110 derives the location information of the device 110 at least in part by using a method including a technique not requiring a GPS satellite receiver to form part of the device 110. In another embodiment the wireless service provider or another party or device deriving the location information of the device 110 derives the location information of the device 110 at least in part by using a hybrid method including a technique requiring a GPS satellite receiver to form part of the device 110 and a technique not requiring a GPS satellite receiver to form part of the device 110. In yet another embodiment, the wireless service provider or another party or device deriving the location information of the device 110 derives the location information of the device 110 at least in part by using a method including a technique

requiring a GPS satellite receiver to form part of the device 110.

**[0047]** However, since the system 100 obtains the location information from the location information provider 150 and not from the device 110, the system 100 can be operated to monitor the location of devices incorporating a GPS satellite receiver as well as devices not incorporating a GPS satellite receiver. Thus, the system 100 does not rely on any particular positioning technology for obtaining the location of the vehicle 105.

**[0048]** In continued reference to **Figure 3**, the system 100 provides user notification and receives user consent to the monitoring the location of the vehicle 105. In this embodiment, the communications interface 120 is further configured for communication with the device 110. In one embodiment, the communication interface 120 is associated with a toll free number such as a 1-800 number. The driver of the vehicle 105 may initiate a telephone call by dialing the toll free number. In another embodiment, the communications interface is associated with a number other than a toll free number. In yet another embodiment, the communications interface 120 is configured to initiate the telephone call.

**[0049]** In one embodiment, the system 100 further includes a validation logic 130 that is configured to identify the device 110 at least in part by obtaining the identifier associated with the device 110. Obtaining the identifier associated with the device 110 ensures that the correct party (e.g., the driver of the vehicle 105 or the user associated with the device 110) is notified that location of the vehicle 105 will be monitored and that the correct party (e.g., the driver of the vehicle 105 or the user associated with the device 110) consents to the monitoring of the location. In one embodiment, the identifier is a telephone number associated with the device 110. In one embodiment, where the communications interface 120 is associated with a toll free number as discussed above, the validation logic 130 is configured to identify the device 110 at least in part by obtaining the telephone number associated with the device 110 via automatic number identification (ANI). As discussed above in reference to Figure 2, in other embodiments, the identifier may be an identifier other than a telephone number.

**[0050]** The system 100 further includes a notification logic 140 that is configured to communicate a signal including data representing an automated voice message. In one embodiment, the automated voice message provides a notice that includes information



indicating that consenting to the monitoring of the location of the vehicle 105 would result in the location of the vehicle 105 or the device 110 being disclosed. In another embodiment, the automated voice message provides a location (web address, etc.) where the notice may be found indicating that consenting to the monitoring of the location of the vehicle 105 would result in the location of the vehicle 105 or the device 110 being disclosed. For example, the automated voice message may indicate that the notice may be found at a web address and provide the web address.

**[0051]** The communications interface 120 is configured to transmit the automated voice message to the device 110. The communications interface 120 is further configured to receive from the device 110 data indicating the user consent to monitoring of the location of the vehicle 105.

**[0052]** In one embodiment, the automated voice message communicates that user's consent to the monitoring of the location of the vehicle 105 may be indicated by performing an action on the communications device (e.g., "to indicate your consent to revealing your location, please press 1.") In this embodiment, the communications interface 120 is configured to receive data indicating that an action was performed on the device 110, which indicates the user's consent (e.g., the user pressed 1).

**[0053]** In another embodiment, the automated voice message communicates that the user's consent to the monitoring of the location of the vehicle 105 may be indicated by speaking a particular word or phrase to be received by the device 110 (e.g., "to indicate your consent to revealing your location, please say 'yes.'") In this embodiment, the communications interface 120 is configured to receive a voice command from the device 110, which indicates the user's consent (e.g., the user said "yes").

**[0054]** In one embodiment, after receiving the user consent to the monitoring of the location of the device 105, the communications interface 120 transmits a request for the location information of the device 110 and receives the location information of the communications device 110. The request for the location information of the device 110 includes the identifier associated with the device 110.

**[0055]** In the illustrated embodiment, after receiving the user consent to the monitoring of the location of the device 105, the communications interface 120 transmits a request for the location information of the device 110 to a location information provider 150 and receives the location information of the communications device 110 from the location information provider 150.

**[0056]** In one embodiment, the notification logic 140 is further configured to communicate a signal including data representing a second automated voice message indicating that consent to the monitoring of the location of the vehicle 105 is revocable via the device 110. In this embodiment, the communications interface 120 is configured to communicate to the device 110 the second automated voice message and to receive confirmation of consent or revocation of consent to the monitoring of the location of the vehicle 105 from the device 110.

**[0057]** In one embodiment, the second automated voice message communicates that the user's confirmation of consent or the user's revocation of consent to the monitoring of the location of the vehicle 105 may be indicated by performing an action on the communications device (e.g., "to indicate that you wish to revoke consent to revealing your location, please press 1.") In this embodiment, the communications interface 120 is configured to receive data indicating that an action was performed on the device 110, which indicates the user's confirmation or revocation of consent (e.g., the user pressed 1).

**[0058]** In another embodiment, the second automated voice message communicates that the user's confirmation of consent or the user's revocation of consent to the monitoring of the location of the vehicle 105 may be indicated by speaking a particular word or phrase to be received by the device 110 (e.g., "to indicate your confirmation of consent to revealing your location, please say 'confirmed.'") In this embodiment, the communications interface 120 is configured to receive a voice command from the device 110, which indicates the user's confirmation or revocation of consent (e.g., the user said "confirmed").

**[0059]** In one embodiment, the user is given the option to temporarily revoke consent to the disclosure of location information. For example, a driver may wish to make available his location to a carrier during certain hours during the work week, but may not want the carrier to be able to obtain the driver's location during the weekend. The driver may operate the device 110 to indicate a date and time when the driver wishes for the monitoring of the location of the vehicle 105 to end or resume. Or the driver may operate the device 110 to indicate an interval of time (e.g., 2 hours) during which the driver wishes to hide the location of the vehicle 105. In this embodiment, the communications interface 120 is configured to receive data indicating a time until which consent to the monitoring of the location of the vehicle 105 is granted or revoked, or an interval of time during which consent to the monitoring of the location of the vehicle 105 is granted or revoked.

**[0060]** In one embodiment, the user is given the option to temporarily revoke consent to the monitoring of the location of the vehicle 105 by texting (e.g., SMS message) the term "hide" using the device 110. In one embodiment, the user is given the option to indicate consent to the monitoring of the location of the vehicle 105 by texting (e.g., SMS message) the term "share" using the device 110. In this embodiment, the communications interface 120 is configured to receive the text message as sent by the device 110, which indicates the user's confirmation or revocation of consent. In another embodiment, the user may speak the terms "hide" or "share" to temporarily revoke consent or to indicate consent to the monitoring of the location of the vehicle 105, respectively. In this embodiment, the communications interface 120 is configured to receive a voice command from the device 110, which indicates the user's confirmation or revocation of consent.

**[0061]** In one embodiment, when the location of the vehicle 105 is being disclosed, the notification logic 140 is further configured to periodically generate and the communications interface 120 is further configured to periodically communicate a reminder notification message indicating that the location of the vehicle 105 is currently being disclosed. In one embodiment, the system 100 reminds the user every 30 days that the location of the vehicle 105 is currently being disclosed. In another embodiment, the system 100 reminds the user more or less often than every 30 days that the location of the vehicle 105 is currently being disclosed.

**[0062]** In one embodiment, the communications interface 120 reminds the user in an automated voice message that the location of the vehicle 105 is currently being disclosed. In another embodiment, the communications interface 120 reminds the user in an SMS message that the location of the vehicle 105 is currently being disclosed. In yet another embodiment, the communications interface 120 reminds the user via electronic communication other than an automated voice message or an SMS message that the location of the vehicle 105 is currently being disclosed.

**[0063]** Example methods may be better appreciated with reference to the flow diagrams of **Figures 4** through **7**. While for purposes of simplicity of explanation, the illustrated methodologies are shown and described as a series of blocks, it is to be appreciated that the methodologies are not limited by the order of the blocks, as some blocks can occur in different orders or concurrently with other blocks from that shown or described. Moreover, less than all the illustrated blocks may be required to implement an example methodology. Furthermore, additional or alternative methodologies can employ additional, not illustrated blocks.

**[0064]** In the flow diagrams, blocks denote “processing blocks” that may be implemented with logic. The processing blocks may represent a method step or an apparatus element for performing the method step. A flow diagram does not depict syntax for any particular programming language, methodology, or style (e.g., procedural, object-oriented). Rather, a flow diagram illustrates functional information one skilled in the art may employ to develop logic to perform the illustrated processing. It will be appreciated that in some examples, program elements like temporary variables, routine loops, and so on, are

not shown. It will be further appreciated that electronic and software applications may involve dynamic and flexible processes so that the illustrated blocks can be performed in other sequences that are different from those shown or that blocks may be combined or separated into multiple components. It will be appreciated that the processes may be implemented using various programming approaches like machine language, procedural, object oriented or artificial intelligence techniques.

**[0065]** In one example, methodologies are implemented as processor executable instructions or operations provided on a computer-readable medium. Thus, in one example, a computer-readable medium may store processor executable instructions operable to perform the methods of **Figures 4** through **7**.

**[0066]** While **Figures 4** through **7** illustrate various actions occurring in serial, it is to be appreciated that various actions illustrated in **Figures 4** through **7** could occur substantially in parallel. While a number of processes are described, it is to be appreciated that a greater or lesser number of processes could be employed and that lightweight processes, regular processes, threads, and other approaches could be employed. It is to be appreciated that other example methods may, in some cases, also include actions that occur substantially in parallel.

**[0067]** **Figure 4** illustrates a flow diagram for an exemplary method 400 for monitoring location of a vehicle. At 410, the method 400 includes receiving a first electronic signal including data representing a request for information regarding the location of the vehicle. At 420, the method 400 includes correlating the vehicle to a communications device based at least in part on the communications device being associated with a user who is associated with the vehicle. At 430, the method 400 includes transmitting a second electronic signal to a location information provider corresponding to a party or device other than the communications device. The second electronic signal includes data representing a request for location information of the communications device. In one embodiment, the second electronic signal includes data representing a telephone number associated with the communications device.

**[0068]** At 440, the method 400 includes receiving a third electronic signal from the location information provider including data representing the location information of the

communications device. At 450, the method 400 includes correlating the location information of the communications device with the location of the vehicle based at least in part on the communications device being associated with the user who is associated with the vehicle. At 460, the method 400 includes transmitting a fourth electronic signal including data representing the location of the vehicle. In one embodiment, the transmitting the fourth electronic signal including data representing the location of the vehicle includes exposing an application programming interface (API) from which the requesting party can access the location of the vehicle.

**[0069]** In one embodiment, the location information of the communications device is originally obtained using a method including a technique other than a technique utilizing a global position system (GPS) satellite receiver that forms part of the communications device. In one embodiment, the location information of the communications device is originally obtained using a method including at least one of: advance forward link trilateration (AFLT), observed time difference (OTD), Cell-ID (CID), and obtaining a range of locations corresponding to a transmission range of a single radio tower.

**[0070]** In one embodiment, the user of the communications device is a driver of the vehicle. In one embodiment, the location information provider corresponds to one of: a wireless service provider providing wireless service to the communications device or a third party that obtains the location information from the wireless service provider providing wireless service to the communications device. In one embodiment, the requesting party corresponds to one of: a freight service provider wherein the location of the vehicle is transmitted to the freight service provider for the freight service provider to have access to location of freight carried by the vehicle, or the driver of the vehicle requesting that the location of the vehicle be transmitted to a freight service provider for the freight service provider to have access to location of freight carried by the vehicle.

**[0071]** **Figure 5** illustrates a flow diagram for an exemplary method 500 for monitoring location of a vehicle. At 510, the method 500 includes transmitting a request signal requesting location information of a communications device. The request signal is transmitted to a party other than the communications device. The communications device is associated with a user of the communications device who is also associated with the vehicle.

At 520, the method 500 includes receiving a location signal including data indicating the location information of the communications device. The location signal is received from a party other than the communications device.

**[0072]** At 530, the method 500 includes transforming the location information of the communications device into location information regarding the vehicle based at least in part on the communications device being associated with the user of the communications device who is also associated with the vehicle.

**[0073]** In one embodiment, the location information of the communications device is originally obtained by a wireless service provider providing wireless service to the communications device. In one embodiment, the location information of the communications device includes location information obtained in compliance with E911. In one embodiment, the location information of the communications device is originally obtained using a method not requiring a global position system (GPS) satellite receiver to form part of the communications device. In one embodiment, the location information of the communications device is originally obtained through triangulation between radio towers. In one embodiment, the location information of the communications device is originally obtained using a range of locations corresponding to a transmission range of a single radio tower.

**[0074]** In one embodiment, the location signal is received from one of: a wireless service provider, or a third party who receives the location information from the wireless service provider.

**[0075]** **Figure 6** illustrates a flow diagram for an exemplary method 600 for receiving consent from a user for monitoring the location of a vehicle associated with the user. At 610, the method 600 includes participating in a telephone call with a communications device associated with the user. In one embodiment, the user of the communications device initiates the telephone call. In another embodiment, the user of the communications device receives the telephone call. At 620, the method 600 includes identifying the communications device at least in part by obtaining an identifier associated with the communications device. In one embodiment, the identifier is a telephone number associated with the communications device. In one embodiment, the communications

device user places the telephone call to a toll free number and the identifying the communications device includes obtaining a telephone number associated with the communications device via automatic number identification (ANI).

**[0076]** In other embodiments, the identifier is an identifier other than a telephone number. For example, the identifier may be a mobile identification number (MIN), an electronic serial number (ESN), an International Mobile Equipment Identity (IMEI), an International Mobile Subscriber Identity (IMSI), a Mobile Equipment Identifier (MEID), a Manufacturer's Serial Number (MSN), a Mobile Subscriber Integrated Services Digital Network (MSISDN) number, a Media Access Control (MAC) address, combinations thereof, and so on.

**[0077]** At 630, the method 600 includes transmitting to the communications device a signal including data representing an automated voice message. The automated voice message communicates to the user of the communications device at least one of: (a) a notice including information indicating that consenting to the monitoring of the location of the vehicle would result in the location of the vehicle or the location of the communications device being disclosed, or (b) a location at which to find the notice. At 640, the method 600 includes receiving from the user via the communications device consent for monitoring the location of the vehicle.

**[0078]** In one embodiment, the receiving from the communications device consent for monitoring the location of the vehicle includes receiving data indicating that the user has performed an action on the communications device. For example, the user may have pressed a key in the communications device, touched or swipe a particular portion of the device's screen, shaken the communications device, combinations thereon and so on. In another embodiment, the receiving from the communications device consent for monitoring the location of the vehicle includes receiving a voice command from the communications device.

**[0079]** In one embodiment, once consent has been obtained from the user of the communications device, the method 600 includes periodically communicating to the user via the communications device a notification message indicating that the location is being disclosed.



**[0080]** In one embodiment, after receiving from the user consent for monitoring the location of the vehicle, the method 600 includes transmitting a request for the location information of the communications device and receiving the location information of the communications device.

**[0081]** In one embodiment, after receiving the location information of the communications device, the method 600 includes communicating the location of the vehicle to a receiving party. In one embodiment, communicating the location of the vehicle to a receiving party includes: (a) transmitting the communicating the location of the vehicle to the receiving party through computer communication, or (b) exposing an application programming interface (API) from which the receiving party can access the location of the vehicle.

**[0082]** **Figure 7** illustrates a flow diagram for an exemplary method 700 for receiving from a user a revocation of consent for monitoring the location of a vehicle associated with the user. At 710, the method 700 includes participating in a telephone call with a communications device associated with the user. In one embodiment, the user initiates the telephone call. In another embodiment, the user receives the telephone call. At 720, the method 700 includes identifying the communications device at least in part by obtaining an identifier associated with the communications device. In one embodiment, the identifier is a telephone number associated with the communications device. In one embodiment, the user places the telephone call to a toll free number and the identifying the communications device includes obtaining a telephone number associated with the communications device via automatic number identification (ANI). In other embodiments, the identifier is an identifier other than a telephone number as discussed above in reference to method 600.

**[0083]** At 730, the method 700 includes communicating to the user via an automated voice message transmitted to the communications device information indicating that consent to the monitoring of the location of the vehicle associated with the user is revocable via the communications device. At 740, the method 700 includes receiving from the communications device revocation of the consent to the monitoring of the location of the vehicle associated with the user.

**[0084]** In one embodiment, the receiving from the communications device revocation of consent to the monitoring of the location of the vehicle includes receiving data indicating that the user has performed an action on the communications device. For example, the user may have pressed a key in the communications device, touched or swiped a particular portion of the device's screen, shaken the communications device, combinations thereon and so on. In another embodiment, the receiving from the communications device revocation of consent to the monitoring of the location of the vehicle includes receiving a voice command from the communications device.

**[0085]** In one embodiment, the revocation of consent is temporary, and the receiving from the communications device revocation of the consent to the monitoring of the location of the vehicle includes receiving data indicating (a) a time at which consent to the monitoring of the location of the vehicle is revoked, (b) a time until which the consent to the monitoring of the location of the vehicle is revoked, or (c) an interval of time during which the consent to the monitoring of the location of the vehicle is revoked. Consent is revoked at the time indicated or at the beginning of the indicated interval of time. Consent is unrevoked at the indicated time until which the consent to the monitoring of the location of the vehicle is revoked or upon expiration of the indicated interval of time during which the consent to the monitoring of the location of the vehicle is revoked.

**[0086]** In one embodiment, the user is given the option to temporarily revoke consent to the monitoring of the location of the vehicle by texting (e.g., SMS message) the term "hide" using the device 110. In one embodiment, the user is given the option to indicate consent to the monitoring of the location of the vehicle by texting (e.g., SMS message) the term "share" using the device 110. In another embodiment, the user may speak the terms "hide" or "share" to temporarily revoke consent or to indicate consent to the monitoring of the location of the vehicle, respectively. In one embodiment, words other than "hide" or "share" may be used to temporarily revoke consent or to indicate consent to the monitoring of the location of the vehicle, respectively.

**[0087]** **Figure 8** illustrates an exemplary user interface 800 for use in conjunction with a system for monitoring of the location of the vehicle. The user interface 800 is operable by the requesting party or the receiving party to set up monitoring of the location of the

vehicle, display information regarding monitoring of the location of the vehicle, and display location of the vehicle.

**[0088]** In the illustrated embodiment, the user interface 800 displays Start/End Monitoring buttons 810a-g operable by a user to end or start monitoring of the location of the vehicle. The user interface 800 further displays the Telephone Number corresponding to the communications device associated with a user associated with the vehicle. The user interface 800 further displays the Monitoring Term, which corresponds to the total amount of time (e.g., 2 hours) that the location of the associated vehicle will be monitored. The user interface 800 further displays the Monitoring Interval, which corresponds to how often within the Monitoring Term (e.g., every 15 minutes) the location of the vehicle is updated. In the illustrated embodiment, the user interface 800 displays the Location as latitude and longitude coordinates. In another embodiment, the user interface 800 displays the Location in a format other than latitude and longitude coordinates. In one embodiment, a user may click on Location to display a map that includes a mark indicating the location of the vehicle on the map.

**[0089]** In one embodiment, an operator of a system for monitoring location of a vehicle or some other party who provides vehicle location monitoring services to a user charges fees to the user on a per-load basis or a per-time-monitored basis. A common practice in the vehicle location monitoring services industry is to charge a user a standard flat monthly fee for monitoring services. This is, at least in part, due to limitations of conventional systems for monitoring vehicle location. The systems and methods for monitoring location of a vehicle disclosed herein provide the provider of vehicle location monitoring services with the ability to charge for the services on a per-load basis or a per-time-monitored basis. For example, a user may operate the user interface 800 or any other means to interface with the system for monitoring location of vehicles to set a time to start or end monitoring of the location of five vehicles (e.g., Start/End Monitoring buttons 810a-g).

**[0090]** In one embodiment where the provider of vehicle location monitoring services provides its services on a per-load or a per-time-monitored basis at a set or negotiated rate per load per unit time, the system may keep track of the number of vehicles (i.e., five) whose location is monitored, as well as the total amount of time for which vehicles' location

is monitored (i.e., total time x 5 vehicles x rate). The operator may use the Monitoring Term to establish the total amount of time (e.g., 2 hours) or the Monitoring Interval to establish the frequency within the Monitoring Term (e.g., every 15 minutes) that the location of the vehicle or vehicles is monitored. With this information available to the operator's billing system, the operator can charge fees to the user on a per-load basis or a per-time-monitored basis.

**[0091]** In the illustrated embodiment, the user interface displays a Partner/Code. The Partner/Code field may display a code corresponding to a partner company or driver. For example, a carrier A may subcontract with another carrier NAT to move freight from location 1 to location 2. The user interface displays the carrier NAT associated with the Telephone Number 555-555-5555.

**[0092]** The user interface 800 further displays a Reference Number. In one embodiment, the Reference Number field is a customizable field that carriers can use to identify a particular load, a particular vehicle, a particular order, etc. In one embodiment, the Reference Number appears in invoices and other documents to facilitate efficient system administration.

**[0093]** The user interface 800 further displays the Status of the vehicle. For example, the Status may indicate that the system is Monitoring the vehicle. In another example, the Status may display that the vehicle is Hidden to indicate that the user associated with the vehicle has temporarily revoked consent to monitoring of the vehicle's location. Other possible Status indicators include: (a) Ready to monitor, which indicates that the monitoring of the location of the vehicle is setup and the system is awaiting location information data, (b) Expired, which indicates that the Monitoring Term has expired, and (c) Denied, which indicates that the user denied consent to monitoring the location of the vehicle.

**[0094]** In one embodiment, the user interface 800 is used to add vehicles whose location is to be monitored. A user may use field 820 to enter the identifier corresponding to the communications device associated with the vehicle whose location is to be monitored. In one embodiment (not illustrated), the user interface 800 provides a pull-down menu from which the user may chose an identifier. The user may further enter the Monitoring Term in field 830, the Monitoring Interval in field 840, the Partner/Code in field

850 and the Reference Number in field 860. In one embodiment (not illustrated), the user interface 800 provides each of these fields as pull-down menus.

**[0095]** In some cases, the requesting party may not know the identifier corresponding to the vehicle or the user may know the identifier but not have authorization to monitoring the location of the vehicle associated with the identifier. In one embodiment (not shown), the user may enter a Partner/Code that serves as verification that the user has obtained authorization from the partner to monitor location of the vehicle associated with the identifier. This feature may also serve to keep the user from learning the identifier in cases where the user associated with the vehicle, the partner, or some other party desires not to reveal the identifier to the requesting party.

**[0096]** In one embodiment, the user associated with the vehicle (e.g., driver) may enter the Partner/Code. For example, the user associated with the vehicle may be an independent driver who wishes for the location information of his vehicle to be monitored by a carrier so that the carrier may assign freight for the driver to haul. However, the carrier may not want every driver in the field to do this freely because of the potential costs associated with monitoring the location of a large number of vehicles. The carrier may require the driver to enter a Partner/Code obtained from the carrier that serves as verification that the driver has obtained authorization from the carrier for the location of the driver's vehicle to be monitored by the carrier.

**[0097]** Referring now to **Figure 9**, an application programming interface (API) 900 is illustrated providing access to a system 910 for monitoring location of a vehicle to a receiving party. The API 900 can be employed, for example, by a programmer 920 or a process 930 to gain access to processing performed by the system 910. For example, a programmer 920 can write a program to access the system 910 (e.g., invoke its operation, obtain its operation, set up its operation, monitor location of a vehicle) where writing the program is facilitated by the presence of the API 900. Rather than programmer 920 having to understand the internals of the system 910, the programmer 920 merely has to learn the interface to the system 910. This facilitates encapsulating the functionality of the system 910 while exposing that functionality.

**[0098]** Similarly, the API 900 can be employed to provide data values to the system 910 or retrieve data values from the system 910. For example, a process 930 that processes location of a vehicle can provide an identifier to the system 910 via the API 900 by, for example, using a call provided in the API 900. Thus, in one example of the API 900, a set of application programming interfaces can be stored on a computer-readable medium. The interfaces can be employed by a programmer, computer component, logic, and so on, to gain access to a system 910 for monitoring location of a vehicle.

**[0099]** **Figure 10** illustrates a computer 1000 that includes a processor 1002, a memory 1004, and I/O Ports 1010 operably connected by a bus 1008. In one example, the computer 1000 may include a validation logic 1030 configured to facilitate validation of a communications device. Thus, the validation logic 1030, whether implemented in computer 1000 as hardware, firmware, software, or a combination thereof may provide means for identifying the communications device at least in part by obtaining an identifier associated with the communications device. In another example, the computer 1000 may include a notification logic 1040 configured to provide notification to the user associated with a vehicle. Thus, the notification logic 1040, whether implemented in computer 1000 as hardware, firmware, software, or a combination thereof may provide means for communicating a signal including data representing automated voice messages that provide notices or directs the user of the communications device to notices that include information indicating (a) that consenting to the monitoring of the vehicle will result in the location information of the vehicle or the communications device being disclosed, (b) that the user may revoke notice by operation of the communications device, and so on. In yet another example, the computer 1000 may include a correlation logic 1070 configured to correlate a vehicle to a communications device or the location information of a communications device to the location of a vehicle based at least in part on the communications device being associated with a user of the communications device who is associated with the vehicle. Thus, the correlation logic 1070, whether implemented in computer 1000 as hardware, firmware, software, or a combination thereof may provide means for correlating a vehicle to a communications device based at least in part on the communications device being associated with the user who is associated with the vehicle, means for correlating the

location information of the communications device with the location of the vehicle based at least in part on the communications device being associated with the user who is associated with the vehicle, or means for transforming the location information of the communications device into location information regarding the vehicle based at least in part on the communications device being associated with the user of the communications device who is also associated with the vehicle. The validation logic 1030, the notification logic 1040, or the correlation logic 1070 may be permanently or removably attached to the computer 1000.

**[00100]** The processor 1002 can be a variety of various processors including dual microprocessor and other multi-processor architectures. The memory 1004 can include volatile memory or non-volatile memory. The non-volatile memory can include, but is not limited to, ROM, PROM, EPROM, EEPROM, and the like. Volatile memory can include, for example, RAM, synchronous RAM (SRAM), dynamic RAM (DRAM), synchronous DRAM (SDRAM), double data rate SDRAM (DDR SDRAM), and direct RAM bus RAM (DRRAM).

**[00101]** A disk 1006 may be operably connected to the computer 1000 via, for example, a communications interface (e.g., card, device) 1018 and an I/O Ports 1010. The disk 1006 can include, but is not limited to, devices like a magnetic disk drive, a solid state disk drive, a floppy disk drive, a tape drive, a Zip drive, a flash memory card, or a memory stick. Furthermore, the disk 1006 can include optical drives like a CD-ROM, a CD recordable drive (CD-R drive), a CD rewriteable drive (CD-RW drive), or a digital video ROM drive (DVD ROM). The memory 1004 can store processes 1014 or data 1016, for example. The disk 1006 or memory 1004 can store an operating system that controls and allocates resources of the computer 1000.

**[00102]** The bus 1008 can be a single internal bus interconnect architecture or other bus or mesh architectures. While a single bus is illustrated, it is to be appreciated that computer 1000 may communicate with various devices, logics, and peripherals using other busses that are not illustrated (e.g., PCIE, SATA, Infiniband, 1394, USB, Ethernet). The bus 1008 can be of a variety of types including, but not limited to, a memory bus or memory controller, a peripheral bus or external bus, a crossbar switch, or a local bus. The local bus can be of varieties including, but not limited to, an industrial standard architecture (ISA) bus, a microchannel architecture (MCA) bus, an extended ISA (EISA) bus, a peripheral component

interconnect (PCI) bus, a universal serial (USB) bus, and a small computer systems interface (SCSI) bus.

**[00103]** The computer 1000 may interact with input/output devices via communications interface 1018 and I/O Ports 1010. Input/output devices can include, but are not limited to, a keyboard, a microphone, a pointing and selection device, cameras, video cards, displays, disk 1006, network devices 1020, and the like. The I/O Ports 1010 can include but are not limited to, serial ports, parallel ports, and USB ports.

**[00104]** The computer 1000 can operate in a network environment and thus may be connected to network devices 1020 via the communications interface 1018, or the I/O Ports 1010. Through the network devices 1020, the computer 1000 may interact with a network. Through the network, the computer 1000 may be logically connected to remote computers. The networks with which the computer 1000 may interact include, but are not limited to, a local area network (LAN), a wide area network (WAN), and other networks. The network devices 1020 can connect to LAN technologies including, but not limited to, fiber distributed data interface (FDDI), copper distributed data interface (CDDI), Ethernet (IEEE 802.3), token ring (IEEE 802.5), wireless computer communication (IEEE 802.11), Bluetooth (IEEE 802.15.1), Zigbee (IEEE 802.15.4) and the like. Similarly, the network devices 1020 can connect to WAN technologies including, but not limited to, point to point links, circuit switching networks like integrated services digital networks (ISDN), packet switching networks, LTE networks, GSM networks, GPRS networks, CDMA networks, and digital subscriber lines (DSL). While individual network types are described, it is to be appreciated that communications via, over, or through a network may include combinations and mixtures of communications.

#### DEFINITIONS

**[00105]** The following includes definitions of selected terms employed herein. The definitions include various examples, forms, or both of components that fall within the scope of a term and that may be used for implementation. The examples are not intended to be limiting. Both singular and plural forms of terms may be within the definitions.



**[00106]** As used in this application, the term “computer component” refers to a computer-related entity, either hardware, firmware, software, a combination thereof, or software in execution. For example, a computer component can be, but is not limited to being, a process running on a processor, a processor, an object, an executable, a thread of execution, a program, and a computer. By way of illustration, both an application running on a server and the server can be computer components. One or more computer components can reside within a process or thread of execution and a computer component can be localized on one computer or distributed between two or more computers.

**[00107]** “Computer communication,” as used herein, refers to a communication between two or more computing devices (e.g., computer, personal digital assistant, cellular telephone) and can be, for example, a network transfer, a file transfer, an applet transfer, an email, a hypertext transfer protocol (HTTP) transfer, and so on. A computer communication can occur across, for example, a wireless system (e.g., IEEE 802.11, IEEE 802.15), an Ethernet system (e.g., IEEE 802.3), a token ring system (e.g., IEEE 802.5), a local area network (LAN), a wide area network (WAN), a point-to-point system, a circuit switching system, a packet switching system, combinations thereof, and so on.

**[00108]** “Computer-readable medium,” as used herein, refers to a medium that participates in directly or indirectly providing signals, instructions or data. A computer-readable medium may take forms, including, but not limited to, non-volatile media, volatile media, and transmission media. Non-volatile media may include, for example, optical or magnetic disks, and so on. Volatile media may include, for example, optical or magnetic disks, dynamic memory and the like. Transmission media may include coaxial cables, copper wire, fiber optic cables, and the like. Transmission media can also take the form of electromagnetic radiation, like that generated during radio-wave and infra-red data communications, or take the form of one or more groups of signals. Common forms of a computer-readable medium include, but are not limited to, a floppy disk, a flexible disk, a hard disk, a magnetic tape, other magnetic media, a CD-ROM, other optical media, punch cards, paper tape, other physical media with patterns of holes, a RAM, a ROM, an EPROM, a FLASH-EPROM, or other memory chip or card, a memory stick, a carrier wave/pulse, and other media from which a computer, a processor or other electronic device can read. Signals

used to propagate instructions or other software over a network, like the Internet, can be considered a “computer-readable medium.”

**[00109]** “Data store,” as used herein, refers to a physical or logical entity that can store data. A data store may be, for example, a database, a table, a file, a list, a queue, a heap, a memory, a register, and so on. A data store may reside in one logical or physical entity or may be distributed between two or more logical or physical entities.

**[00110]** A “logic,” as used herein, includes but is not limited to hardware, firmware, software or combinations of each to perform a function(s) or an action(s), or to cause a function or action from another logic, method, or system. For example, based on a desired application or needs, a logic may include a software controlled microprocessor, discrete logic like an application specific integrated circuit (ASIC), a programmed logic device, a memory device containing instructions, or the like. A logic may include one or more gates, combinations of gates, or other circuit components. A logic may also be fully embodied as software. Where multiple logical logics are described, it may be possible to incorporate the multiple logical logics into one physical logic. Similarly, where a single logical logic is described, it may be possible to distribute that single logical logic between multiple physical logics.

**[00111]** An “operable connection,” or a connection by which entities are “operably connected,” is one in which signals, physical communications, or logical communications may be sent or received. Typically, an operable connection includes a physical interface, an electrical interface, or a data interface, but it is to be noted that an operable connection may include differing combinations of these or other types of connections sufficient to allow operable control. For example, two entities can be operably connected by being able to communicate signals to each other directly or through one or more intermediate entities like a processor, operating system, a logic, software, or other entity. Logical or physical communication channels can be used to create an operable connection.

**[00112]** “Signal,” as used herein, includes but is not limited to one or more electrical or optical signals, analog or digital signals, data, one or more computer or processor instructions, messages, a bit or bit stream, or other means that can be received, transmitted or detected.

**[00113]** “Software,” as used herein, includes but is not limited to, one or more computer or processor instructions that can be read, interpreted, compiled, or executed and that cause a computer, processor, or other electronic device to perform functions, actions or behave in a desired manner. The instructions may be embodied in various forms like routines, algorithms, modules, methods, threads, or programs including separate applications or code from dynamically or statically linked libraries. Software may also be implemented in a variety of executable or loadable forms including, but not limited to, a stand-alone program, a function call (local or remote), a servlet, an applet, instructions stored in a memory, part of an operating system or other types of executable instructions. It will be appreciated by one of ordinary skill in the art that the form of software may depend, for example, on requirements of a desired application, the environment in which it runs, or the desires of a designer/programmer or the like. It will also be appreciated that computer-readable or executable instructions can be located in one logic or distributed between two or more communicating, co-operating, or parallel processing logics and thus can be loaded or executed in serial, parallel, massively parallel and other manners.

**[00114]** Suitable software for implementing the various components of the example systems and methods described herein may be produced using programming languages and tools like Java, Java Script, Java.NET, ASP.NET, VB.NET, Cocoa, Pascal, C#, C++, C, CGI, Perl, SQL, APIs, SDKs, assembly, firmware, microcode, or other languages and tools. Software, whether an entire system or a component of a system, may be embodied as an article of manufacture and maintained or provided as part of a computer-readable medium as defined previously. Another form of the software may include signals that transmit program code of the software to a recipient over a network or other communication medium. Thus, in one example, a computer-readable medium has a form of signals that represent the software/firmware as it is downloaded from a web server to a user. In another example, the computer-readable medium has a form of the software/firmware as it is maintained on the web server. Other forms may also be used.

**[00115]** “User,” as used herein, includes but is not limited to one or more persons, software, computers or other devices, or combinations of these.

**[00116]** To the extent that the term “includes” or “including” is employed in the detailed description or the claims, it is intended to be inclusive in a manner similar to the term “comprising” as that term is interpreted when employed as a transitional word in a claim. Furthermore, to the extent that the term “or” is employed in the detailed description or claims (e.g., A or B) it is intended to mean “A or B or both”. When the applicants intend to indicate “only A or B but not both” then the term “only A or B but not both” will be employed. Thus, use of the term “or” herein is the inclusive, and not the exclusive use. See, Bryan A. Garner, *A Dictionary of Modern Legal Usage* 624 (2d. Ed. 1995).

**[00117]** While example systems, methods, and so on, have been illustrated by describing examples, and while the examples have been described in considerable detail, it is not the intention to restrict or in any way limit the scope of the appended claims to such detail. It is, of course, not possible to describe every conceivable combination of components or methodologies for purposes of describing the systems, methods, and so on, described herein. Additional advantages and modifications will readily appear to those skilled in the art. Therefore, the invention is not limited to the specific details, and illustrative examples shown or described. Thus, this application is intended to embrace alterations, modifications, and variations that fall within the scope of the appended claims. Furthermore, the preceding description is not meant to limit the scope of the invention. Rather, the scope of the invention is to be determined by the appended claims and their equivalents.

ABSTRACT

A machine or group of machines for monitoring location of at least one of a vehicle or freight carried by the vehicle includes a server comprising a central processing unit, a memory, a clock, and a server communication transceiver that receives location information of a mobile device, the mobile device comprising a GPS receiver, a microprocessor and a wireless communication transceiver coupled to the GPS receiver, the mobile device comprising the GPS receiver programmed to receive data sent by a plurality of GPS satellites, calculate location information of the mobile device comprising the GPS receiver and transmit the location information.

## CLAIMS

1. A machine or group of machines for monitoring location of at least one of a vehicle or freight carried by the vehicle, comprising:

a mobile device comprising a GPS receiver, a display, a microprocessor and a wireless communication transceiver coupled to the GPS receiver, the mobile device comprising the GPS receiver programmed to receive data sent by a plurality of GPS satellites, calculate location information of the mobile device comprising the GPS receiver and transmit the location information;

a server comprising a central processing unit, a memory, a clock, and a server communication transceiver that receives the location information of the mobile device comprising the GPS receiver, and the central processing unit programmed to:

receive a request for information regarding the location of the vehicle or the freight carried by the vehicle;

request location information of the mobile device comprising the GPS receiver from a location information provider;

receive a signal that indicates that consent was given to transmission of location information;

receive from the location information provider location information of the mobile device comprising the GPS receiver, wherein the location information of the mobile device comprising the GPS receiver originated from a device other than the mobile device comprising the GPS receiver itself; and

estimate the location of the vehicle or the freight carried by the vehicle based at least in part on the location information of the mobile device comprising the GPS receiver; and

communicate the location of the vehicle or the freight carried by the vehicle to cause a representation of the location of the vehicle or the freight carried by the vehicle.

2. A machine or group of machines for monitoring location of at least one of a vehicle or freight carried by the vehicle, comprising:

a server comprising a central processing unit, a memory, a clock, and a server communication transceiver that receives location information of a mobile device, the mobile device comprising a GPS receiver, a microprocessor and a wireless communication transceiver coupled to the GPS receiver, the mobile device comprising the GPS receiver programmed to receive data sent by a plurality of GPS satellites, calculate location information of the mobile device comprising the GPS receiver and transmit the location information, the central processing unit programmed to:

receive a request for information regarding the location of the vehicle or the freight carried by the vehicle;

request location information of the mobile device comprising the GPS receiver from a location information provider;

receive a signal that indicates that consent was given to transmission of location information;

receive from the location information provider location information of the mobile device comprising the GPS receiver, wherein the location information of the mobile device comprising the GPS receiver originated from a device other than the mobile device comprising the GPS receiver itself; and

estimate the location of the vehicle or the freight carried by the vehicle based at least in part on the location information of the mobile device comprising the GPS receiver; and

communicate the location of the vehicle or the freight carried by the vehicle to cause a representation of the location of the vehicle or the freight carried by the vehicle.

3. The machine or group of machines of claim 2, wherein the central processing unit is programmed to the location of the vehicle or the freight carried by the vehicle based at

least in part on a vehicle reference number or a freight reference number associated with the mobile device comprising the GPS receiver.

4. The machine or group of machines of claim 2, wherein the location information provider corresponds to at least one of:

a wireless service provider providing wireless service to the mobile device comprising the GPS receiver,

a third party that obtains the location information of the mobile device comprising the GPS receiver from the wireless service provider providing wireless service to the mobile device comprising the GPS receiver, and

a party that has access to the location information of the mobile device comprising the GPS receiver but is other than the wireless service provider or the third party that obtains the location information of the mobile device comprising the GPS receiver from the wireless service provider.

5. The machine or group of machines of claim 2, wherein the central processing unit is programmed to communicate the location of the vehicle or the freight carried by the vehicle to cause the representation of the location of the vehicle or the freight carried by the vehicle by one of:

exposing an application programming interface (API) from which the location of the at least one of the vehicle or the freight carried by the vehicle is obtained, or

interfacing with an exposed application programming interface (API) through which the location of the at least one of the vehicle or the freight carried by the vehicle is transmitted.

6. The machine or group of machines of claim 2, wherein the central processing unit is programmed to communicate the location of the vehicle or the freight carried by the vehicle



to cause the representation of the location of the vehicle or the freight carried by the vehicle to a device associated with one of:

a freight service provider,

a party to whom the freight service provider provides freight services, and

a party that provides location information services to the freight service provider or to the party to whom the freight service provider provides freight services.

7. The machine or group of machines of claim 2, wherein the central processing unit receiving from the location information provider location information of the mobile device comprising the GPS receiver is the signal that indicates that consent was given to transmission of location information of the mobile device comprising the GPS receiver.

8. The machine or group of machines of claim 2, wherein the central processing unit is programmed to communicate the location of the vehicle or the freight carried by the vehicle to cause the representation of the location of the vehicle or the freight carried by the vehicle by causing display of a visual representation of the location of the vehicle or the freight carried by the vehicle on a remote device's user interface by displaying the location of the vehicle or the freight carried by the vehicle as a) latitude and longitude coordinates, b) city/state, or c) a map that includes a mark indicating the location of the vehicle on the map.

9. The machine or group of machines of claim 2, wherein the location information of the mobile device comprising the GPS receiver is originally obtained using a method including a technique utilizing the GPS receiver that forms part of the mobile device comprising the GPS receiver.

10. The machine or group of machines of claim 2, wherein the location information of the mobile device comprising the GPS receiver is originally obtained using a method

including a technique other than a technique utilizing the GPS receiver that forms part of the mobile device comprising the GPS receiver.

11. The machine or group of machines of claim 2, wherein the location information of the mobile device comprising the GPS receiver comprising the GPS receiver is originally obtained through techniques including at least one:

triangulation between radio towers,

obtaining a range of locations corresponding to a transmission range of a single radio tower,

advance forward link trilateration (AFLT),

observed time difference (OTD), and

Cell-ID (CID).

12. A machine or group of machines for monitoring location of at least one of a vehicle or freight carried by the vehicle, comprising:

a server comprising a central processing unit, a memory, a clock, and a server communication transceiver that receives location information of a mobile device, the mobile device comprising a GPS receiver, a microprocessor and a wireless communication transceiver coupled to the GPS receiver, the mobile device comprising the GPS receiver programmed to receive data sent by a plurality of GPS satellites, calculate location information of the mobile device comprising the GPS receiver and transmit the location information, the central processing unit programmed to:

determine whether consent was given to transmit location information of the mobile device comprising the GPS receiver;

estimate the location of the at least one of the vehicle or the freight carried by the vehicle based on the location information of the mobile device comprising the GPS receiver;

receive a request for information regarding the location of the at least one of the vehicle or the freight carried by the vehicle;

request location information of the mobile device comprising a GPS receiver from a location information provider corresponding to a device other than the mobile device comprising the GPS receiver;

receive from the location information provider the location information of the mobile device comprising the GPS receiver; and

communicate the location of the at least one of the vehicle or the freight carried by the vehicle to cause a representation of the location of the vehicle or the freight carried by the vehicle by a remote device.

13. The machine or group of machines of claim 12, wherein the location information provider corresponds to at least one of:

a wireless service provider providing wireless service to the mobile device comprising the GPS receiver,

a third party that obtains the location information of the mobile device comprising the GPS receiver from the wireless service provider providing wireless service to the mobile device comprising the GPS receiver, and

a party that has access to the location information of the mobile device comprising the GPS receiver but is other than the wireless service provider or the third party that obtains the location information of the mobile device comprising the GPS receiver from the wireless service provider.

14. The machine or group of machines of claim 12, wherein the location information of the mobile device comprising the GPS receiver is originally obtained using a method including a technique utilizing a global position machine or group of machines (GPS) satellite receiver that forms part of the mobile device comprising the GPS receiver.

15. The machine or group of machines of claim 12, wherein the location information of the mobile device comprising the GPS receiver is originally obtained using a method including a technique other than a technique utilizing a global position machine or group of machines (GPS) satellite receiver that forms part of the mobile device comprising the GPS receiver.

16. (New) The machine or group of machines of claim 12, wherein the location information of the mobile device comprising the GPS receiver is originally obtained through techniques including at least one:

triangulation between radio towers,  
obtaining a range of locations corresponding to a transmission range of a single radio tower,  
advance forward link trilateration (AFLT),  
observed time difference (OTD), and  
Cell-ID (CID).

17. The machine or group of machines of claim 12, wherein the central processing unit is programmed to communicate the location of the vehicle or the freight carried by the vehicle to cause the representation of the location of the vehicle or the freight carried by the vehicle by one of:

exposing an application programming interface (API) from which the location of the at least one of the vehicle or the freight carried by the vehicle is obtained, or

interfacing with an exposed application programming interface (API) through which the location of the at least one of the vehicle or the freight carried by the vehicle is transmitted.

18. The machine or group of machines of claim 12, wherein the request for information regarding the location of the at least one of the vehicle or the freight carried by the vehicle is received from a device associated with:

a freight service provider,

a party to whom the freight service provider provides freight services, or

a party that provides location information services to the freight service provider or to the party to whom the freight service provider provides freight services.

19. The machine or group of machines of claim 12, wherein the central processing unit is programmed to communicate the location of the vehicle or the freight carried by the vehicle to cause the representation of the location of the vehicle or the freight carried by the vehicle by causing display of a visual representation of the location of the vehicle or the freight carried by the vehicle on the remote device's user interface by displaying the location of the vehicle or the freight carried by the vehicle as latitude and longitude coordinates.

20. The machine or group of machines of claim 12, wherein the central processing unit is programmed to communicate the location of the vehicle or the freight carried by the vehicle to cause the representation of the location of the vehicle or the freight carried by the vehicle by causing display of a visual representation of the location of the vehicle or the freight carried by the vehicle on the remote device's user interface by displaying the location of the vehicle or the freight carried by the vehicle as city/state.

21. The machine or group of machines of claim 12, wherein the central processing unit is programmed to communicate the location of the vehicle or the freight carried by the vehicle to cause the representation of the location of the vehicle or the freight carried by the vehicle by causing display of a visual representation of the location of the vehicle or the

freight carried by the vehicle on the remote device's user interface by displaying a map that includes a mark indicating the location of the vehicle on the map.

22. The machine or group of machines of claim 12, wherein the central processing unit receiving from the location information provider location information of the mobile device comprising the GPS receiver serves to determine whether consent was given to transmit location information of a mobile device comprising the GPS receiver.

23. A machine or group of machines for monitoring location of at least one of a vehicle or freight carried by the vehicle, the machine or group of machines comprising:

a server comprising a central processing unit, a memory, a clock, and a server communication transceiver that receives location information of a mobile device, the mobile device comprising a GPS receiver, a microprocessor and a wireless communication transceiver coupled to the GPS receiver, the mobile device comprising the GPS receiver programmed to receive data sent by a plurality of GPS satellites, calculate location information of the mobile device comprising the GPS receiver and transmit the location information, the central processing unit programmed to:

receive a request for information regarding the location of the vehicle or the freight carried by the vehicle, and

request location information of the vehicle or the freight carried by the vehicle from a location information provider;

receive an indication that consent to transmission of location information has been given; and

receive location information of the vehicle or the freight carried by the vehicle from the location information provider;

estimate the location of the vehicle or the freight carried by the vehicle from the location information received from the location information provider;

communicate the location of the vehicle or the freight carried by the vehicle.

24. The machine or group of machines of claim 23, wherein the location of the vehicle or the freight carried is estimated based on a vehicle reference number or a freight reference number associated with the mobile device comprising the GPS receiver.

25. The machine or group of machines of claim 23, wherein the location information provider corresponds to a device associated with at least one of:

a wireless service provider providing wireless service to the mobile device comprising the GPS receiver,

a third party that obtains the location information of the mobile device comprising the GPS receiver from the wireless service provider providing wireless service to the mobile device comprising the GPS receiver, and

a party that has access to the location information of the mobile device comprising the GPS receiver but is other than the wireless service provider or the third party that obtains the location information of the mobile device comprising the GPS receiver from the wireless service provider.

26. The machine or group of machines of claim 23, wherein the wherein the central processing unit is programmed to communicate the location of the vehicle or the freight carried by the vehicle by one of:

exposing an application programming interface (API) from which the location of the at least one of the vehicle or the freight carried by the vehicle is obtained, or

interfacing with an exposed application programming interface (API) through which the location of the at least one of the vehicle or the freight carried by the vehicle is transmitted.

27. The machine or group of machines of claim 23, wherein the central processing unit is programmed to communicate the location of the vehicle or the freight carried by the vehicle to one or more of:

a freight service provider,

a party to whom the freight service provider provides freight services, and

a party that provides location information services to the freight service provider or to the party to whom the freight service provider provides freight services.

28. The machine or group of machines of claim 23, wherein the central processing unit receiving from the location information provider location information of the mobile device comprising the GPS receiver is the indication that consent to transmission of location information of the mobile device comprising the GPS receiver has been given.

29. The system of claim 23, wherein the location information of the mobile device comprising the GPS receiver is originally obtained using a method including a technique utilizing the GPS receiver that forms part of the mobile device comprising the GPS receiver.

30. The system of claim 23, wherein the location information of the mobile device comprising the GPS receiver is originally obtained using a method including a technique other than a technique utilizing the GPS receiver that forms part of the mobile device comprising the GPS receiver.



## Electronic Patent Application Fee Transmittal

<b>Application Number:</b>				
<b>Filing Date:</b>				
<b>Title of Invention:</b>	MACHINE OR GROUP OF MACHINES FOR MONITORING LOCATION OF A VEHICLE OR FREIGHT CARRIED BY A VEHICLE			
<b>First Named Inventor/Applicant Name:</b>	Bennett H. Adelson			
<b>Filer:</b>	Luis Antonio Carrion			
<b>Attorney Docket Number:</b>	MCROP0102USH			
Filed as Small Entity				
<b>Filing Fees for Track I Prioritized Examination - Nonprovisional Application under 35 USC 111(a)</b>				
<b>Description</b>	<b>Fee Code</b>	<b>Quantity</b>	<b>Amount</b>	<b>Sub-Total in USD(\$)</b>
<b>Basic Filing:</b>				
Utility filing Fee (Electronic filing)	4011	1	70	70
Utility Search Fee	2111	1	300	300
Utility Examination Fee	2311	1	360	360
Request for Prioritized Examination	2817	1	2000	2000
<b>Pages:</b>				
<b>Claims:</b>				
Claims in excess of 20	2202	10	40	400
Independent Claims in Excess of 3	2201	1	210	210

Description	Fee Code	Quantity	Amount	Sub-Total in USD(\$)
<b>Miscellaneous-Filing:</b>				
Publ. Fee- Early, Voluntary, or Normal	1504	1	0	0
PROCESSING FEE, EXCEPT PROV. APPLS.	2830	1	70	70
<b>Petition:</b>				
<b>Patent-Appeals-and-Interference:</b>				
<b>Post-Allowance-and-Post-Issuance:</b>				
<b>Extension-of-Time:</b>				
<b>Miscellaneous:</b>				
<b>Total in USD (\$)</b>				<b>3410</b>

## Electronic Acknowledgement Receipt

<b>EFS ID:</b>	24517179
<b>Application Number:</b>	14987707
<b>International Application Number:</b>	
<b>Confirmation Number:</b>	7143
<b>Title of Invention:</b>	MACHINE OR GROUP OF MACHINES FOR MONITORING LOCATION OF A VEHICLE OR FREIGHT CARRIED BY A VEHICLE
<b>First Named Inventor/Applicant Name:</b>	Bennett H. Adelson
<b>Customer Number:</b>	130163
<b>Filer:</b>	Luis Antonio Carrion
<b>Filer Authorized By:</b>	
<b>Attorney Docket Number:</b>	MCROP0102USH
<b>Receipt Date:</b>	04-JAN-2016
<b>Filing Date:</b>	
<b>Time Stamp:</b>	21:30:02
<b>Application Type:</b>	Utility under 35 USC 111(a)

### Payment information:

Submitted with Payment	yes
Payment Type	Credit Card
Payment was successfully received in RAM	\$3410
RAM confirmation Number	8159
Deposit Account	180988
Authorized User	CARRION, LUIS

The Director of the USPTO is hereby authorized to charge indicated fees and credit any overpayment as follows:

Charge any Additional Fees required under 37 CFR 1.16 (National application filing, search, and examination fees)

Charge any Additional Fees required under 37 CFR 1.17 (Patent application and reexamination processing fees)

Ruiz Food Products, Inc.

Charge any Additional Fees required under 37 CFR 1.19 (Document supply fees)  
 Charge any Additional Fees required under 37 CFR 1.20 (Post Issuance fees)  
 Charge any Additional Fees required under 37 CFR 1.21 (Miscellaneous fees and charges)

**File Listing:**

Document Number	Document Description	File Name	File Size(Bytes)/ Message Digest	Multi Part /.zip	Pages (if appl.)
1	TrackOne Request	Track1.pdf	141147	no	2
			da6a5133a8e7143f51ef2ac947754f9559b81a1f		
<b>Warnings:</b>					
<b>Information:</b>					
2	Power of Attorney	P0102USH-EXEC_POA.pdf	357176	no	3
			3dc312f7e3078a31d3496f7d795d85f6d7a1ace8		
<b>Warnings:</b>					
<b>Information:</b>					
3	Oath or Declaration filed	P0102USB_Executed_Dec_Assign.pdf	298098	no	3
			ee6e1ab5513311925a6523e3b1280b67be9e8584		
<b>Warnings:</b>					
<b>Information:</b>					
4	Application Data Sheet	P0102USH_ADS.pdf	1823593	no	9
			23ba8c203aecbc61c14b67f2c2c9e5870fcb06cd		
<b>Warnings:</b>					
<b>Information:</b>					
5	Transmittal of New Application	Transmittal.pdf	137789	no	2
			8bb5e8f5678c3dbf54a052b99f2983b59aa1ec89		
<b>Warnings:</b>					
<b>Information:</b>					
6	Drawings-only black and white line drawings	P0102USF-DRAW.pdf	566956	no	10
			d19935073c21c8babf0f64d00aaadf33dc9a61a3		
<b>Warnings:</b>					
<b>Information:</b>					
7		P0102USH-IDS.pdf	309535	yes	4
			9e4f61bfa1dbc858df60d618be8938c705f5ca36		
<b>Warnings:</b>					
<b>Information:</b>					
<b>Multipart Description/PDF files in .zip description</b>					
	<b>Document Description</b>		<b>Start</b>		<b>End</b>

	Transmittal Letter		1	2
	Information Disclosure Statement (IDS) Form (SB08)		3	4

**Warnings:**

**Information:**

8	Specification	MCROP0102USH_Spec-final.pdf	475819	no	32
			5430a35a154a56b4504ee8e8bc20166d026b4a3f		

**Warnings:**

**Information:**

9	Abstract	MCROP0102USH_Abst-final.pdf	114119	no	1
			817de38024981e91517a794b0d73d1a264b04629		

**Warnings:**

**Information:**

10	Claims	P0102USH_Claims_Final.pdf	168044	no	11
			1b3d3b3898490470c1589dd715ddc1687080f7db		

**Warnings:**

**Information:**

11	Fee Worksheet (SB06)	fee-info.pdf	43376	no	2
			7b185c257d3b6d8b5625e4f16ce0585e3ce4ce73		

**Warnings:**

**Information:**

<b>Total Files Size (in bytes):</b>			4435652		
-------------------------------------	--	--	---------	--	--

**This Acknowledgement Receipt evidences receipt on the noted date by the USPTO of the indicated documents, characterized by the applicant, and including page counts, where applicable. It serves as evidence of receipt similar to a Post Card, as described in MPEP 503.**

**New Applications Under 35 U.S.C. 111**

**If a new application is being filed and the application includes the necessary components for a filing date (see 37 CFR 1.53(b)-(d) and MPEP 506), a Filing Receipt (37 CFR 1.54) will be issued in due course and the date shown on this Acknowledgement Receipt will establish the filing date of the application.**

**National Stage of an International Application under 35 U.S.C. 371**

**If a timely submission to enter the national stage of an international application is compliant with the conditions of 35 U.S.C. 371 and other applicable requirements a Form PCT/DO/EO/903 indicating acceptance of the application as a national stage submission under 35 U.S.C. 371 will be issued in addition to the Filing Receipt, in due course.**

**New International Application Filed with the USPTO as a Receiving Office**

**If a new international application is being filed and the international application includes the necessary components for an international filing date (see PCT Article 11 and MPEP 1810), a Notification of the International Application Number and of the International Filing Date (Form PCT/RO/105) will be issued in due course, subject to prescriptions concerning national security, and the date shown on this Acknowledgement Receipt will establish the international filing date of the application.**

## Electronic Acknowledgement Receipt

<b>EFS ID:</b>	24517179
<b>Application Number:</b>	14987707
<b>International Application Number:</b>	
<b>Confirmation Number:</b>	7143
<b>Title of Invention:</b>	MACHINE OR GROUP OF MACHINES FOR MONITORING LOCATION OF A VEHICLE OR FREIGHT CARRIED BY A VEHICLE
<b>First Named Inventor/Applicant Name:</b>	Bennett H. Adelson
<b>Customer Number:</b>	130163
<b>Filer:</b>	Luis Antonio Carrion
<b>Filer Authorized By:</b>	
<b>Attorney Docket Number:</b>	MCROP0102USH
<b>Receipt Date:</b>	04-JAN-2016
<b>Filing Date:</b>	
<b>Time Stamp:</b>	21:30:02
<b>Application Type:</b>	Utility under 35 USC 111(a)

### Payment information:

Submitted with Payment	yes
Payment Type	Credit Card
Payment was successfully received in RAM	\$3410
RAM confirmation Number	8159
Deposit Account	180988
Authorized User	CARRION, LUIS

The Director of the USPTO is hereby authorized to charge indicated fees and credit any overpayment as follows:

Charge any Additional Fees required under 37 CFR 1.16 (National application filing, search, and examination fees)

Charge any Additional Fees required under 37 CFR 1.17 (Patent application and reexamination processing fees)

Ruiz Food Products, Inc.

Charge any Additional Fees required under 37 CFR 1.19 (Document supply fees)  
 Charge any Additional Fees required under 37 CFR 1.20 (Post Issuance fees)  
 Charge any Additional Fees required under 37 CFR 1.21 (Miscellaneous fees and charges)

**File Listing:**

Document Number	Document Description	File Name	File Size(Bytes)/ Message Digest	Multi Part /.zip	Pages (if appl.)
1	TrackOne Request	Track1.pdf	141147	no	2
			da6a5133a8e7143f51ef2ac947754f9559b81a1f		
<b>Warnings:</b>					
<b>Information:</b>					
2	Power of Attorney	P0102USH-EXEC_POA.pdf	357176	no	3
			3dc312f7e3078a31d3496f7d795d85f6d7a1ace8		
<b>Warnings:</b>					
<b>Information:</b>					
3	Oath or Declaration filed	P0102USB_Executed_Dec_Assign.pdf	298098	no	3
			ee6e1ab5513311925a6523e3b1280b67be9e8584		
<b>Warnings:</b>					
<b>Information:</b>					
4	Application Data Sheet	P0102USH_ADS.pdf	1823593	no	9
			23ba8c203aecbc61c14b67f2c2c9e5870fcb06cd		
<b>Warnings:</b>					
<b>Information:</b>					
5	Transmittal of New Application	Transmittal.pdf	137789	no	2
			8bb5e8f5678c3dbf54a052b99f2983b59aa1ec89		
<b>Warnings:</b>					
<b>Information:</b>					
6	Drawings-only black and white line drawings	P0102USF-DRAW.pdf	566956	no	10
			d19935073c21c8babf0f64d00aaadf33dc9a61a3		
<b>Warnings:</b>					
<b>Information:</b>					
7		P0102USH-IDS.pdf	309535	yes	4
			9e4f61bfa1dbc858df60d618be8938c705f5ca36		
<b>Warnings:</b>					
<b>Information:</b>					
<b>Multipart Description/PDF files in .zip description</b>					
	<b>Document Description</b>		<b>Start</b>		<b>End</b>

	Transmittal Letter		1	2
	Information Disclosure Statement (IDS) Form (SB08)		3	4

**Warnings:**

**Information:**

8	Specification	MCROP0102USH_Spec-final.pdf	475819 5430a35a154a56b4504ee8e8bc20166d026b4a3f	no	32
---	---------------	-----------------------------	--	----	----

**Warnings:**

**Information:**

9	Abstract	MCROP0102USH_Abst-final.pdf	114119 817de38024981e91517a794b0d73d1a264b04629	no	1
---	----------	-----------------------------	--	----	---

**Warnings:**

**Information:**

10	Claims	P0102USH_Claims_Final.pdf	168044 1b3d3b3898490470c1589dd715ddc1687080f7db	no	11
----	--------	---------------------------	--	----	----

**Warnings:**

**Information:**

11	Fee Worksheet (SB06)	fee-info.pdf	43376 7b185c257d3b6d8b5625e4f16ce0585e3ce4ce73	no	2
----	----------------------	--------------	---	----	---

**Warnings:**

**Information:**

<b>Total Files Size (in bytes):</b>			4435652		
-------------------------------------	--	--	---------	--	--

**This Acknowledgement Receipt evidences receipt on the noted date by the USPTO of the indicated documents, characterized by the applicant, and including page counts, where applicable. It serves as evidence of receipt similar to a Post Card, as described in MPEP 503.**

**New Applications Under 35 U.S.C. 111**

**If a new application is being filed and the application includes the necessary components for a filing date (see 37 CFR 1.53(b)-(d) and MPEP 506), a Filing Receipt (37 CFR 1.54) will be issued in due course and the date shown on this Acknowledgement Receipt will establish the filing date of the application.**

**National Stage of an International Application under 35 U.S.C. 371**

**If a timely submission to enter the national stage of an international application is compliant with the conditions of 35 U.S.C. 371 and other applicable requirements a Form PCT/DO/EO/903 indicating acceptance of the application as a national stage submission under 35 U.S.C. 371 will be issued in addition to the Filing Receipt, in due course.**

**New International Application Filed with the USPTO as a Receiving Office**

**If a new international application is being filed and the international application includes the necessary components for an international filing date (see PCT Article 11 and MPEP 1810), a Notification of the International Application Number and of the International Filing Date (Form PCT/RO/105) will be issued in due course, subject to prescriptions concerning national security, and the date shown on this Acknowledgement Receipt will establish the international filing date of the application.**



Under the Paperwork Reduction Act of 1995, no persons are required to respond to a collection of information unless it displays a valid OMB control number.

## TRANSMITTAL FOR POWER OF ATTORNEY TO ONE OR MORE REGISTERED PRACTITIONERS

**NOTE:** This form is to be submitted with the Power of Attorney by Applicant form (PTO/AIA/82B) to identify the application to which the Power of Attorney is directed, in accordance with 37 CFR 1.5, unless the application number and filing date are identified in the Power of Attorney by Applicant form. If neither form PTO/AIA/82A nor form PTO/AIA82B identifies the application to which the Power of Attorney is directed, the Power of Attorney will not be recognized in the application.

Application Number	Not Yet Assigned
Filing Date	Herewith
First Named Inventor	Bennett H. Adelson
Title	MACHINE OR GROUP OF MACHINES FOR MONITORING LOCATION OF A VEHICLE OR FREIGHT CARRIED BY A VEHICLE
Art Unit	Unknown
Examiner Name	Not Yet Assigned
Attorney Docket Number	MCROP0102USH

**SIGNATURE of Applicant or Patent Practitioner**

Signature	/Luis A. Carrion/	Date (Optional)	2016-01-04
Name	Luis A. Carrion	Registration Number	61,255
Title (if Applicant is a juristic entity)			
Applicant Name (if Applicant is a juristic entity)			

**NOTE:** This form must be signed in accordance with 37 CFR 1.33. See 37 CFR 1.4(d) for signature requirements and certifications. If more than one applicant, use multiple forms.

\*Total of 1 forms are submitted.

This collection of information is required by 37 CFR 1.131, 1.32, and 1.33. The information is required to obtain or retain a benefit by the public which is to file (and by the USPTO to process) an application. Confidentiality is governed by 35 U.S.C. 122 and 37 CFR 1.11 and 1.14. This collection is estimated to take 3 minutes to complete, including gathering, preparing, and submitting the completed application form to the USPTO. Time will vary depending upon the individual case. Any comments on the amount of time you require to complete this form and/or suggestions for reducing this burden, should be sent to the Chief Information Officer, U.S. Patent and Trademark Office, U.S. Department of Commerce, P.O. Box 1450, Alexandria, VA 22313-1450. **DO NOT SEND FEES OR COMPLETED FORMS TO THIS ADDRESS. SEND TO: Commissioner for Patents, P.O. Box 1450, Alexandria, VA 22313-1450.**

*If you need assistance in completing the form, call 1-800-PTO-9199 and select option 2.*

Ruiz Food Products, Inc.

Under the Paperwork Reduction Act of 1995, no persons are required to respond to a collection of information unless it displays a valid OMB control number.

**POWER OF ATTORNEY TO PROSECUTE APPLICATIONS BEFORE THE USPTO**

I hereby revoke all previous powers of attorney given in the application identified in the attached statement under 37 CFR 3.73(c).

I hereby appoint:

Practitioners associated with Customer Number: 130163

OR

Practitioner(s) named below (if more than ten patent practitioners are to be named, then a customer number must be used):

Name	Registration Number

Name	Registration Number

As attorney(s) or agent(s) to represent the undersigned before the United States Patent and Trademark Office (USPTO) in connection with any and all patent applications assigned only to the undersigned according to the USPTO assignment records or assignments documents attached to this form in accordance with 37 CFR 3.73(c).

Please change the correspondence address for the application identified in the attached statement under 37 CFR 3.73(c) to:

The address associated with Customer Number: 130163

OR

Firm or Individual Name:			
Address:			
City:	State:	Zip:	
Country:			
Telephone:			Email:

Assignee Name and Address: **MacroPoint, LLC**  
 6050 Oak Tree Blvd., Suite 150  
 Cleveland, Ohio 44131

A copy of this form, together with a statement under 37 CFR 3.73(c) (Form PTO/AIA/96 or equivalent) is required to be Filed in each application in which this form is used. The statement under 37 CFR 3.73(c) may be completed by one of The practitioners appointed in this form, and must identify the application in which this Power of Attorney is to be filed.

**SIGNATURE of Assignee of Record**

The individual whose signature and title is supplied below is authorized to act on behalf of the assignee

Signature	<i>Bennett Adelson</i>	Date	<i>3-17-2015</i>
Name	<i>Bennett Adelson</i>	Telephone	<i>216-569-0144</i>
Title	<i>President</i>		

This collection of information is required by 37 CFR 1.31, 1.32 and 1.33. The information is required to obtain or retain a benefit by the public which is to file (and by the USPTO to process) an application. Confidentiality is governed by 35 U.S.C. 122 and 37 CFR 1.11 and 1.14. This collection is estimated to take 3 minutes to complete, including gathering, preparing, and submitting the completed application form to the USPTO. Time will vary depending upon the individual case. Any comments on the amount of time you require to complete this form and/or suggestions for reducing this burden, should be sent to the Chief Information Officer, U.S. Patent and Trademark Office, U.S. Department of Commerce, P.O. Box 1450, Alexandria, VA 22313-1450. DO NOT SEND FEES OR COMPLETED FORMS TO THIS ADDRESS. SEND TO: Commissioner for Patents, P.O. Box 1450, Alexandria, VA 22313-1450.

If you need assistance in completing the form, call 1-800-PTO-9199 and select option 2.

## Privacy Act Statement

The **Privacy Act of 1974 (P.L. 93-579)** requires that you be given certain information in connection with your submission of the attached form related to a patent application or patent. Accordingly, pursuant to the requirements of the Act, please be advised that: (1) the general authority for the collection of this information is 35 U.S.C. 2(b)(2); (2) furnishing of the information solicited is voluntary; and (3) the principal purpose for which the information is used by the U.S. Patent and Trademark Office is to process and/or examine your submission related to a patent application or patent. If you do not furnish the requested information, the U.S. Patent and Trademark Office may not be able to process and/or examine your submission, which may result in termination of proceedings or abandonment of the application or expiration of the patent.

The information provided by you in this form will be subject to the following routine uses:

1. The information on this form will be treated confidentially to the extent allowed under the Freedom of Information Act (5 U.S.C. 552) and the Privacy Act (5 U.S.C. 552a). Records from this system of records may be disclosed to the Department of Justice to determine whether disclosure of these records is required by the Freedom of Information Act.
2. A record from this system of records may be disclosed, as a routine use, in the course of presenting evidence to a court, magistrate, or administrative tribunal, including disclosures to opposing counsel in the course of settlement negotiations.
3. A record in this system of records may be disclosed, as a routine use, to a Member of Congress submitting a request involving an individual, to whom the record pertains, when the individual has requested assistance from the Member with respect to the subject matter of the record.
4. A record in this system of records may be disclosed, as a routine use, to a contractor of the Agency having need for the information in order to perform a contract. Recipients of information shall be required to comply with the requirements of the Privacy Act of 1974, as amended, pursuant to 5 U.S.C. 552a(m).
5. A record related to an International Application filed under the Patent Cooperation Treaty in this system of records may be disclosed, as a routine use, to the International Bureau of the World Intellectual Property Organization, pursuant to the Patent Cooperation Treaty.
6. A record in this system of records may be disclosed, as a routine use, to another federal agency for purposes of National Security review (35 U.S.C. 181) and for review pursuant to the Atomic Energy Act (42 U.S.C. 218(c)).
7. A record from this system of records may be disclosed, as a routine use, to the Administrator, General Services, or his/her designee, during an inspection of records conducted by GSA as part of that agency's responsibility to recommend improvements in records management practices and programs, under authority of 44 U.S.C. 2904 and 2906. Such disclosure shall be made in accordance with the GSA regulations governing inspection of records for this purpose, and any other relevant (i.e., GSA or Commerce) directive. Such disclosure shall not be used to make determinations about individuals.
8. A record from this system of records may be disclosed, as a routine use, to the public after either publication of the application pursuant to 35 U.S.C. 122(b) or issuance of a patent pursuant to 35 U.S.C. 151. Further, a record may be disclosed, subject to the limitations of 37 CFR 1.14, as a routine use, to the public if the record was filed in an application which became abandoned or in which the proceedings were terminated and which application is referenced by either a published application, an application open to public inspection or an issued patent.
9. A record from this system of records may be disclosed, as a routine use, to a Federal, State, or local law enforcement agency, if the USPTO becomes aware of a violation or potential violation of law or regulation.

Docket No. MCROP0102USB

PATENT (US)

COMBINED DECLARATION AND ASSIGNMENT FOR UTILITY OR DESIGN PATENT APPLICATION

Title of Invention: SYSTEMS AND METHODS FOR MONITORING LOCATION OF A VEHICLE

As a below named inventor, I hereby declare that this declaration and assignment are directed to:

Table with 2 columns: Application No. (Express Mail Label No.), Filing Date (Deposit Date), Amended on (if applicable). Values: 14/069,364; October 31, 2013.

or, if no application is identified above, the attached application.

DECLARATION

The above application was made or authorized to be made by me.

I believe that I am the original or an original joint inventor of a claimed invention in the application.

My residence, mailing address and citizenship are as stated below next to my name.

I have reviewed and understood the contents of the application, including the claims.

I hereby acknowledge that any willful false statement made in this declaration is punishable under Section 1001 of Title 18 of the United States Code by fine or imprisonment of not more than five (5) years, or both.

DOMESTIC PRIORITY CLAIM FOR BENEFIT OF EARLIER U.S./PCT APPLICATION(S) UNDER 35 U.S.C. 120

I hereby claim, on my behalf or on behalf of the below-identified assignee, i.e. MacroPoint, the benefit under 35 U.S.C. § 120 of any United States application(s) or PCT international application(s) designating the United States of America that is/are listed below and, insofar as the subject matter of each of the claims of this application is not disclosed in that/those prior application(s) in the manner provided by the first paragraph of 35 U.S.C. § 112, I acknowledge the duty to disclose material information as defined in 37 C.F.R. § 1.56 which became available between the filing date of the prior application and the national or PCT international filing date of this application.

Table with 3 columns: U.S. APPLICATION NUMBER, DATE OF FILING (day, month, year), PATENT NUMBER. Values: 13/613,321; 13 September 2012; 8330626; 13/429,618; 26 March 2012.

CLAIM FOR BENEFIT OF EARLIER U.S. PROVISIONAL APPLICATION(S) UNDER 35 U.S.C. 119(e)

I hereby claim, on my behalf or on behalf of the below-identified assignee, i.e. MacroPoint, the benefit under 35 U.S.C. § 119(e) of any United States provisional application(s) that is/are listed below.

Table with 2 columns: U.S. PROVISIONAL APPLICATION NUMBER, DATE OF FILING (day, month, year). Empty rows.

FOREIGN PRIORITY CLAIM

I hereby claim, on my behalf or on behalf of the below-identified assignee, i.e. MacroPoint, priority benefits under 35 U.S.C. § 119 (a)-(d) or (f), § 172 or § 365(b) of any foreign application(s) for patent, inventor's or plant breeder's rights certificate(s), or § 365(a) of any PCT international application(s) which designated at least one country other than the United States of America, that is/are listed below, and have

also identified below any foreign application(s) for patent, inventor's or plant breeder's rights certificate(s) or any PCT international application(s) having a filing date before that of the application(s) on which priority is claimed.

COUNTRY	APPLICATION NUMBER	DATE OF FILING (day, month, year)	PRIORITY NOT CLAIMED

**DUTY OF DISCLOSURE**

I hereby acknowledge the duty to disclose to the Patent and Trademark Office all information known to me to be material to patentability as defined in 37 C.F.R. § 1.56, which in pertinent part states that information is material to patentability when it is not cumulative to information already of record or being made of record in the application, and (1) it establishes, by itself or in combination with other information, a prima facie case of unpatentability of a claim; or (2) it refutes, or is inconsistent with, a position the applicant takes in: (i) opposing an argument of unpatentability relied on by the Office, or (ii) asserting an argument of patentability. A prima facie case of unpatentability is established when the information compels a conclusion that a claim is unpatentable under the preponderance of evidence, burden-of-proof standard, giving each term in the claim its broadest reasonable construction consistent with the specification, and before any consideration is given to evidence which may be submitted in an attempt to establish a contrary conclusion of patentability.

**ASSIGNMENT**

For good and valuable consideration, receipt of which is hereby acknowledged, I have sold and assigned and hereby sell and assign to:

Assignee(s)	Address
MacroPoint, LLC	6050 Oak Tree Blvd., Cleveland, Ohio 44131

{If more than one assignee is listed, each owns an undivided equal share in the application and underlying invention so far as concerns the United States unless otherwise indicated or agreed to by the assignees.}

and the successors and assigns thereof, the entire right, title and interest to (i) said invention, (ii) said application, (iii) any and all provisional applications on which priority is claimed, any and all related patent applications in the United States or a country foreign thereto, including continuations, continuations-in-part, divisionals, renewals, conversions, substitutes, reexaminations, reissues, convention, international (PCT) and other applications based in whole or in part upon said invention or upon said applications, (iv) any and all patents, including renewals, reissues, certificates of reexamination and extensions thereof granted for said invention or upon said applications, for the full term or terms for which the same may be granted, and (v) all priority rights that are or may be predicated upon or arise from said invention, said applications and said patents.

If the application number and filing date are not set forth above, authorization is hereby given for any attorney of record in the subject patent application to insert below the application number and filing date information for this application when that information becomes available.

Application No.	
Filing Date	

I hereby covenant that no assignment, sale, agreement or encumbrance has been or will be made or entered into that would conflict with this assignment and sale.

I authorize said Assignee(s) to file in my own name or in its own name applications for patent in any country that are predicated upon or arise from said invention, said applications and said patents.

I appoint said Assignee(s) as my common representative to represent me before all competent international authorities in connection with any international application predicated upon or arising from said invention, said applications and said patents.

I further covenant that Assignee(s) will, upon request, be provided promptly with all pertinent facts and documents relating to said application, said invention and said Letters Patent as may be known and accessible to me and will testify as to the same in any proceeding related thereto and will promptly execute and deliver to Assignee(s), or the legal representative thereof, any and all papers, instruments or affidavits required to apply for, obtain, maintain and enforce said application, said invention and said Letters Patent which may be necessary or desirable to carry out the purposes hereof.

I agree to perform all affirmative acts which may be necessary to obtain a grant of a valid U.S. patent and any foreign patents to the Assignee(s) and to vest all rights hereby conveyed to the Assignee(s) as fully and entirely as the same would have been held by me if this Assignment had not been made.

I agree that this assignment shall be construed in accordance with the law of the state/country in which the first above-listed Assignee is located as above indicated, and without regard to its conflicts of laws provisions.

<b>Legal Name of Inventor:</b>		Bennett H. Adelson	
Inventor's signature:	<i>Bennett Adelson</i>	Date:	10/30/2013
Residence: (City & State/Country):	Highland Heights, Ohio, US	Citizenship:	US
Post Office Address:	330 Glasgow Drive Highland Heights, OH 44143		

<b>Legal Name of Inventor:</b>			
Inventor's signature:		Date:	
Residence: (City & State/Country):		Citizenship:	
Post Office Address:			

<b>Legal Name of Inventor:</b>			
Inventor's signature:		Date:	
Residence: (City & State/Country):		Citizenship:	
Post Office Address:			

<b>Legal Name of Inventor:</b>			
Inventor's signature:		Date:	
Residence: (City & State/Country):		Citizenship:	
Post Office Address:			

<b>Legal Name of Inventor:</b>			
Inventor's signature:		Date:	
Residence: (City & State/Country):		Citizenship:	
Post Office Address:			

Under the Paperwork Reduction Act of 1995, no persons are required to respond to a collection of information unless it contains a valid OMB control number.

<b>Application Data Sheet 37 CFR 1.76</b>		Attorney Docket Number	MCROP0102USH
		Application Number	
Title of Invention	MACHINE OR GROUP OF MACHINES FOR MONITORING LOCATION OF A VEHICLE OR FREIGHT CARRIED BY A VEHICLE		
The application data sheet is part of the provisional or nonprovisional application for which it is being submitted. The following form contains the bibliographic data arranged in a format specified by the United States Patent and Trademark Office as outlined in 37 CFR 1.76. This document may be completed electronically and submitted to the Office in electronic format using the Electronic Filing System (EFS) or the document may be printed and included in a paper filed application.			

**Secrecy Order 37 CFR 5.2:**

Portions or all of the application associated with this Application Data Sheet may fall under a Secrecy Order pursuant to 37 CFR 5.2 (Paper filers only. Applications that fall under Secrecy Order may not be filed electronically.)

**Inventor Information:**

Inventor	1				Remove	
Legal Name						
Prefix	Given Name	Middle Name	Family Name	Suffix		
	Bennett	H.	Adelson			
Residence Information (Select One) • US Residency Non US Residency Active US Military Service						
City	Highland Heights	State/Province	OH	Country of Residence	US	
Mailing Address of Inventor:						
Address 1	330 Glasgow Drive					
Address 2						
City	Highland Heights	State/Province	OH			
Postal Code	44143	Country	US			
All Inventors Must Be Listed - Additional Inventor Information blocks may be generated within this form by selecting the Add button.						Add

**Correspondence Information:**

Enter either Customer Number or complete the Correspondence Information section below.  
For further information see 37 CFR 1.33(a).

An Address is being provided for the correspondence Information of this application.

Customer Number	130163		
Email Address	mailroom@rennerotto.com	Add Email	Remove Email
Email Address	lcarrion@rennerotto.com	Add Email	Remove Email

**Application Information:**

Title of the Invention	MACHINE OR GROUP OF MACHINES FOR MONITORING LOCATION OF A VEHICLE OR FREIGHT CARRIED BY A VEHICLE		
Attorney Docket Number	MCROP0102USH	Small Entity Status Claimed	<input checked="" type="checkbox"/>
Application Type	Nonprovisional		
Subject Matter	Utility		
Total Number of Drawing Sheets (if any)	10	Suggested Figure for Publication (if any)	

Ruiz Food Products, Inc.

Under the Paperwork Reduction Act of 1995, no persons are required to respond to a collection of information unless it contains a valid OMB control number.

<b>Application Data Sheet 37 CFR 1.76</b>	Attorney Docket Number	MCROP0102USH
	Application Number	
Title of Invention	MACHINE OR GROUP OF MACHINES FOR MONITORING LOCATION OF A VEHICLE OR FREIGHT CARRIED BY A VEHICLE	

**Filing By Reference:**

Only complete this section when filing an application by reference under 35 U.S.C. 111(c) and 37 CFR 1.57(a). Do not complete this section if application papers including a specification and any drawings are being filed. Any domestic benefit or foreign priority information must be provided in the appropriate section(s) below (i.e., "Domestic Benefit/National Stage Information" and "Foreign Priority Information").

For the purposes of a filing date under 37 CFR 1.53(b), the description and any drawings of the present application are replaced by this reference to the previously filed application, subject to conditions and requirements of 37 CFR 1.57(a).

Application number of the previously filed application	Filing date (YYYY-MM-DD)	Intellectual Property Authority or Country

**Publication Information:**

Request Early Publication (Fee required at time of Request 37 CFR 1.219)

**Request Not to Publish.** I hereby request that the attached application not be published under 35 U.S.C. 122(b) and certify that the invention disclosed in the attached application **has not and will not** be the subject of an application filed in another country, or under a multilateral international agreement, that requires publication at eighteen months after filing.

**Representative Information:**

Representative information should be provided for all practitioners having a power of attorney in the application. Providing this information in the Application Data Sheet does not constitute a power of attorney in the application (see 37 CFR 1.32). Either enter Customer Number or complete the Representative Name section below. If both sections are completed the customer Number will be used for the Representative Information during processing.

Please Select One:	<input checked="" type="radio"/> Customer Number	US Patent Practitioner	<input type="radio"/> Limited Recognition (37 CFR 11.9)
Customer Number	130163		

**Domestic Benefit/National Stage Information:**

This section allows for the applicant to either claim benefit under 35 U.S.C. 119(e), 120, 121, 365(c), or 386(c) or indicate National Stage entry from a PCT application. Providing benefit claim information in the Application Data Sheet constitutes the specific reference required by 35 U.S.C. 119(e) or 120, and 37 CFR 1.78.

When referring to the current application, please leave the "Application Number" field blank.

Prior Application Status	Pending		Remove
Application Number	Continuity Type	Prior Application Number	Filing or 371(c) Date (YYYY-MM-DD)
	Continuation of	14752005	2015-06-26



Under the Paperwork Reduction Act of 1995, no persons are required to respond to a collection of information unless it contains a valid OMB control number.

<b>Application Data Sheet 37 CFR 1.76</b>		Attorney Docket Number	MCROP0102USH
		Application Number	
Title of Invention	MACHINE OR GROUP OF MACHINES FOR MONITORING LOCATION OF A VEHICLE OR FREIGHT CARRIED BY A VEHICLE		

Prior Application Status		Patented		Remove	
Application Number	Continuity Type	Prior Application Number	Filing Date (YYYY-MM-DD)	Patent Number	Issue Date (YYYY-MM-DD)
14752005	Continuation of	14661774	2015-03-18	9087313	2015-07-21
Prior Application Status		Patented		Remove	
Application Number	Continuity Type	Prior Application Number	Filing Date (YYYY-MM-DD)	Patent Number	Issue Date (YYYY-MM-DD)
14661774	Continuation of	14069364	2013-10-31	9070295	2015-06-30
Prior Application Status		Patented		Remove	
Application Number	Continuity Type	Prior Application Number	Filing Date (YYYY-MM-DD)	Patent Number	Issue Date (YYYY-MM-DD)
14069364	Continuation of	13613321	2012-09-13	8604943	2013-12-10
Prior Application Status		Patented		Remove	
Application Number	Continuity Type	Prior Application Number	Filing Date (YYYY-MM-DD)	Patent Number	Issue Date (YYYY-MM-DD)
13613321	Continuation of	13429618	2012-03-26	8330626	2012-12-11
Additional Domestic Benefit/National Stage Data may be generated within this form by selecting the <b>Add</b> button.					Add

### Foreign Priority Information:

This section allows for the applicant to claim priority to a foreign application. Providing this information in the application data sheet constitutes the claim for priority as required by 35 U.S.C. 119(b) and 37 CFR 1.55. When priority is claimed to a foreign application that is eligible for retrieval under the priority document exchange program (PDX)<sup>i</sup> the information will be used by the Office to automatically attempt retrieval pursuant to 37 CFR 1.55(i)(1) and (2). Under the PDX program, applicant bears the ultimate responsibility for ensuring that a copy of the foreign application is received by the Office from the participating foreign intellectual property office, or a certified copy of the foreign priority application is filed, within the time period specified in 37 CFR 1.55(g)(1).

Remove			
Application Number	Country <sup>i</sup>	Filing Date (YYYY-MM-DD)	Access Code <sup>i</sup> (if applicable)
Additional Foreign Priority Data may be generated within this form by selecting the <b>Add</b> button.			
Add			

### Statement under 37 CFR 1.55 or 1.78 for AIA (First Inventor to File) Transition Applications

Under the Paperwork Reduction Act of 1995, no persons are required to respond to a collection of information unless it contains a valid OMB control number.

<b>Application Data Sheet 37 CFR 1.76</b>	Attorney Docket Number	MCROP0102USH
	Application Number	
Title of Invention	MACHINE OR GROUP OF MACHINES FOR MONITORING LOCATION OF A VEHICLE OR FREIGHT CARRIED BY A VEHICLE	

<input type="checkbox"/> This application (1) claims priority to or the benefit of an application filed before March 16, 2013 and (2) also contains, or contained at any time, a claim to a claimed invention that has an effective filing date on or after March 16, 2013. NOTE: By providing this statement under 37 CFR 1.55 or 1.78, this application, with a filing date on or after March 16, 2013, will be examined under the first inventor to file provisions of the AIA.
---

<b>Application Data Sheet 37 CFR 1.76</b>	Attorney Docket Number	MCROP0102USH
	Application Number	
Title of Invention	MACHINE OR GROUP OF MACHINES FOR MONITORING LOCATION OF A VEHICLE OR FREIGHT CARRIED BY A VEHICLE	

## Authorization or Opt-Out of Authorization to Permit Access:

When this Application Data Sheet is properly signed and filed with the application, applicant has provided written authority to permit a participating foreign intellectual property (IP) office access to the instant application-as-filed (see paragraph A in subsection 1 below) and the European Patent Office (EPO) access to any search results from the instant application (see paragraph B in subsection 1 below).

Should applicant choose not to provide an authorization identified in subsection 1 below, applicant **must opt-out** of the authorization by checking the corresponding box A or B or both in subsection 2 below.

**NOTE:** This section of the Application Data Sheet is **ONLY** reviewed and processed with the **INITIAL** filing of an application. After the initial filing of an application, an Application Data Sheet cannot be used to provide or rescind authorization for access by a foreign IP office(s). Instead, Form PTO/SB/39 or PTO/SB/69 must be used as appropriate.

### 1. Authorization to Permit Access by a Foreign Intellectual Property Office(s)

**A. Priority Document Exchange (PDX)** - Unless box A in subsection 2 (opt-out of authorization) is checked, the undersigned hereby **grants the USPTO authority** to provide the European Patent Office (EPO), the Japan Patent Office (JPO), the Korean Intellectual Property Office (KIPO), the State Intellectual Property Office of the People's Republic of China (SIPO), the World Intellectual Property Organization (WIPO), and any other foreign intellectual property office participating with the USPTO in a bilateral or multilateral priority document exchange agreement in which a foreign application claiming priority to the instant patent application is filed, access to: (1) the instant patent application-as-filed and its related bibliographic data, (2) any foreign or domestic application to which priority or benefit is claimed by the instant application and its related bibliographic data, and (3) the date of filing of this Authorization. See 37 CFR 1.14(h)(1).

**B. Search Results from U.S. Application to EPO** - Unless box B in subsection 2 (opt-out of authorization) is checked, the undersigned hereby **grants the USPTO authority** to provide the EPO access to the bibliographic data and search results from the instant patent application when a European patent application claiming priority to the instant patent application is filed. See 37 CFR 1.14(h)(2).

The applicant is reminded that the EPO's Rule 141(1) EPC (European Patent Convention) requires applicants to submit a copy of search results from the instant application without delay in a European patent application that claims priority to the instant application.

### 2. Opt-Out of Authorizations to Permit Access by a Foreign Intellectual Property Office(s)

A. Applicant **DOES NOT** authorize the USPTO to permit a participating foreign IP office access to the instant application-as-filed. If this box is checked, the USPTO will not be providing a participating foreign IP office with any documents and information identified in subsection 1A above.

B. Applicant **DOES NOT** authorize the USPTO to transmit to the EPO any search results from the instant patent application. If this box is checked, the USPTO will not be providing the EPO with search results from the instant application.

**NOTE:** Once the application has published or is otherwise publicly available, the USPTO may provide access to the application in accordance with 37 CFR 1.14.

<b>Application Data Sheet 37 CFR 1.76</b>	Attorney Docket Number	MCROP0102USH
	Application Number	
Title of Invention	MACHINE OR GROUP OF MACHINES FOR MONITORING LOCATION OF A VEHICLE OR FREIGHT CARRIED BY A VEHICLE	

## Applicant Information:

Providing assignment information in this section does not substitute for compliance with any requirement of part 3 of Title 37 of CFR to have an assignment recorded by the Office.

<b>Applicant</b>	1	<input type="button" value="Remove"/>	
<p>If the applicant is the inventor (or the remaining joint inventor or inventors under 37 CFR 1.45), this section should not be completed. The information to be provided in this section is the name and address of the legal representative who is the applicant under 37 CFR 1.43; or the name and address of the assignee, person to whom the inventor is under an obligation to assign the invention, or person who otherwise shows sufficient proprietary interest in the matter who is the applicant under 37 CFR 1.46. If the applicant is an applicant under 37 CFR 1.46 (assignee, person to whom the inventor is obligated to assign, or person who otherwise shows sufficient proprietary interest) together with one or more joint inventors, then the joint inventor or inventors who are also the applicant should be identified in this section.</p>			
<input type="button" value="Clear"/>			
<input checked="" type="radio"/> Assignee	Legal Representative under 35 U.S.C. 117	Joint Inventor	
Person to whom the inventor is obligated to assign.		Person who shows sufficient proprietary interest	
If applicant is the legal representative, indicate the authority to file the patent application, the inventor is:			
<div style="border: 1px solid black; height: 20px; width: 100%;"></div>			
Name of the Deceased or Legally Incapacitated Inventor: <input type="text"/>			
If the Applicant is an Organization check here. <input checked="" type="checkbox"/>			
Organization Name	MacroPoint LLC		
<b>Mailing Address Information For Applicant:</b>			
Address 1	6050 Oak Tree Blvd., Suite 150		
Address 2			
City	Cleveland	State/Province	OH
Country	US	Postal Code	44131
Phone Number		Fax Number	
Email Address			
Additional Applicant Data may be generated within this form by selecting the Add button. <input type="button" value="Add"/>			

## Assignee Information including Non-Applicant Assignee Information:

Providing assignment information in this section does not substitute for compliance with any requirement of part 3 of Title 37 of CFR to have an assignment recorded by the Office.

<b>Application Data Sheet 37 CFR 1.76</b>	Attorney Docket Number	MCROP0102USH
	Application Number	
Title of Invention	MACHINE OR GROUP OF MACHINES FOR MONITORING LOCATION OF A VEHICLE OR FREIGHT CARRIED BY A VEHICLE	

<b>Assignee</b>	1
-----------------	---

Complete this section if assignee information, including non-applicant assignee information, is desired to be included on the patent application publication. An assignee-applicant identified in the "Applicant Information" section will appear on the patent application publication as an applicant. For an assignee-applicant, complete this section only if identification as an assignee is also desired on the patent application publication.

If the Assignee or Non-Applicant Assignee is an Organization check here.

Prefix	Given Name	Middle Name	Family Name	Suffix

**Mailing Address Information For Assignee including Non-Applicant Assignee:**

Address 1				
Address 2				
City		State/Province		
Country <sup>i</sup>		Postal Code		
Phone Number		Fax Number		
Email Address				

Additional Assignee or Non-Applicant Assignee Data may be generated within this form by selecting the Add button.

**Signature:**

**NOTE:** This Application Data Sheet must be signed in accordance with 37 CFR 1.33(b). However, if this Application Data Sheet is submitted with the **INITIAL** filing of the application and either box A or B is not checked in subsection 2 of the "Authorization or Opt-Out of Authorization to Permit Access" section, then this form must also be signed in accordance with 37 CFR 1.14(c).

This Application Data Sheet **must** be signed by a patent practitioner if one or more of the applicants is a **juristic entity** (e.g., corporation or association). If the applicant is two or more joint inventors, this form must be signed by a patent practitioner, **all** joint inventors who are the applicant, or one or more joint inventor-applicants who have been given power of attorney (e.g., see USPTO Form PTO/AIA/81) on behalf of **all** joint inventor-applicants.

See 37 CFR 1.4(d) for the manner of making signatures and certifications.

<b>Signature</b>	/Luis A. Carrion/		Date (YYYY-MM-DD)	2016-01-04
First Name	Luis	Last Name	Carrion	Registration Number
				61255

Additional Signature may be generated within this form by selecting the Add button.

Under the Paperwork Reduction Act of 1995, no persons are required to respond to a collection of information unless it contains a valid OMB control number.

<b>Application Data Sheet 37 CFR 1.76</b>	Attorney Docket Number	MCROP0102USH
	Application Number	
Title of Invention	MACHINE OR GROUP OF MACHINES FOR MONITORING LOCATION OF A VEHICLE OR FREIGHT CARRIED BY A VEHICLE	

This collection of information is required by 37 CFR 1.76. The information is required to obtain or retain a benefit by the public which is to file (and by the USPTO to process) an application. Confidentiality is governed by 35 U.S.C. 122 and 37 CFR 1.14. This collection is estimated to take 23 minutes to complete, including gathering, preparing, and submitting the completed application data sheet form to the USPTO. Time will vary depending upon the individual case. Any comments on the amount of time you require to complete this form and/or suggestions for reducing this burden, should be sent to the Chief Information Officer, U.S. Patent and Trademark Office, U.S. Department of Commerce, P.O. Box 1450, Alexandria, VA 22313-1450. DO NOT SEND FEES OR COMPLETED FORMS TO THIS ADDRESS. **SEND TO: Commissioner for Patents, P.O. Box 1450, Alexandria, VA 22313-1450.**

## Privacy Act Statement

The Privacy Act of 1974 (P.L. 93-579) requires that you be given certain information in connection with your submission of the attached form related to a patent application or patent. Accordingly, pursuant to the requirements of the Act, please be advised that: (1) the general authority for the collection of this information is 35 U.S.C. 2(b)(2); (2) furnishing of the information solicited is voluntary; and (3) the principal purpose for which the information is used by the U.S. Patent and Trademark Office is to process and/or examine your submission related to a patent application or patent. If you do not furnish the requested information, the U.S. Patent and Trademark Office may not be able to process and/or examine your submission, which may result in termination of proceedings or abandonment of the application or expiration of the patent.

The information provided by you in this form will be subject to the following routine uses:

1. The information on this form will be treated confidentially to the extent allowed under the Freedom of Information Act (5 U.S.C. 552) and the Privacy Act (5 U.S.C. 552a). Records from this system of records may be disclosed to the Department of Justice to determine whether the Freedom of Information Act requires disclosure of these records.
2. A record from this system of records may be disclosed, as a routine use, in the course of presenting evidence to a court, magistrate, or administrative tribunal, including disclosures to opposing counsel in the course of settlement negotiations.
3. A record in this system of records may be disclosed, as a routine use, to a Member of Congress submitting a request involving an individual, to whom the record pertains, when the individual has requested assistance from the Member with respect to the subject matter of the record.
4. A record in this system of records may be disclosed, as a routine use, to a contractor of the Agency having need for the information in order to perform a contract. Recipients of information shall be required to comply with the requirements of the Privacy Act of 1974, as amended, pursuant to 5 U.S.C. 552a(m).
5. A record related to an International Application filed under the Patent Cooperation Treaty in this system of records may be disclosed, as a routine use, to the International Bureau of the World Intellectual Property Organization, pursuant to the Patent Cooperation Treaty.
6. A record in this system of records may be disclosed, as a routine use, to another federal agency for purposes of National Security review (35 U.S.C. 181) and for review pursuant to the Atomic Energy Act (42 U.S.C. 218(c)).
7. A record from this system of records may be disclosed, as a routine use, to the Administrator, General Services, or his/her designee, during an inspection of records conducted by GSA as part of that agency's responsibility to recommend improvements in records management practices and programs, under authority of 44 U.S.C. 2904 and 2906. Such disclosure shall be made in accordance with the GSA regulations governing inspection of records for this purpose, and any other relevant (i.e., GSA or Commerce) directive. Such disclosure shall not be used to make determinations about individuals.
8. A record from this system of records may be disclosed, as a routine use, to the public after either publication of the application pursuant to 35 U.S.C. 122(b) or issuance of a patent pursuant to 35 U.S.C. 151. Further, a record may be disclosed, subject to the limitations of 37 CFR 1.14, as a routine use, to the public if the record was filed in an application which became abandoned or in which the proceedings were terminated and which application is referenced by either a published application, an application open to public inspections or an issued patent.
9. A record from this system of records may be disclosed, as a routine use, to a Federal, State, or local law enforcement agency, if the USPTO becomes aware of a violation or potential violation of law or regulation.

**CERTIFICATION AND REQUEST FOR PRIORITIZED EXAMINATION  
 UNDER 37 CFR 1.102(e) (Page 1 of 1)**

First Named Inventor:	Bennett H. Adelson	Nonprovisional Application Number (if known):	herewith
Title of Invention:	MACHINE OR GROUP OF MACHINES FOR MONITORING LOCATION OF A VEHICLE OR FREIGHT CARRIED BY A VEHICLE		

**APPLICANT HEREBY CERTIFIES THE FOLLOWING AND REQUESTS PRIORITIZED EXAMINATION FOR THE ABOVE-IDENTIFIED APPLICATION.**

1. The processing fee set forth in 37 CFR 1.17(i), the prioritized examination fee set forth in 37 CFR 1.17(c), and if not already paid, the publication fee set forth in 37 CFR 1.18(d) have been filed with the request. The basic filing fee, search fee, examination fee, and any required excess claims and application size fees are filed with the request or have been already been paid.
2. The application contains or is amended to contain no more than four independent claims and no more than thirty total claims, and no multiple dependent claims.
3. The applicable box is checked below:

**I.  Original Application (Track One) - Prioritized Examination under § 1.102(e)(1)**

- i. (a) The application is an original nonprovisional utility application filed under 35 U.S.C. 111(a). This certification and request is being filed with the utility application via EFS-Web.  
 ---OR---  
 (b) The application is an original nonprovisional plant application filed under 35 U.S.C. 111(a). This certification and request is being filed with the plant application in paper.
- ii. An executed oath or declaration under 37 CFR 1.63 is filed with the application.

**II.  Request for Continued Examination - Prioritized Examination under § 1.102(e)(2)**

- i. A request for continued examination has been filed with, or prior to, this form.
- ii. If the application is a utility application, this certification and request is being filed via EFS-Web.
- iii. The application is an original nonprovisional utility application filed under 35 U.S.C. 111(a), or is a national stage entry under 35 U.S.C. 371.
- iv. This certification and request is being filed prior to the mailing of a first Office action responsive to the request for continued examination.
- v. No prior request for continued examination has been granted prioritized examination status under 37 CFR 1.102(e)(2).

Signature /Luis A. Carrion/	Date January 4, 2016
Name (Print/Typed) Luis A. Carrion	Practitioner Registration Number 61,255

**Note:** Signatures of all the inventors or assignees of record of the entire interest or their representative(s) are required in accordance with 37 CFR 1.33 and 11.18. Please see 37 CFR 1.4(d) for the form of the signature. If necessary, submit multiple forms for more than one signature, see below\*.

\*Total of 1 forms are submitted.



## Privacy Act Statement

The **Privacy Act of 1974 (P.L. 93-579)** requires that you be given certain information in connection with your submission of the attached form related to a patent application or patent. Accordingly, pursuant to the requirements of the Act, please be advised that: (1) the general authority for the collection of this information is 35 U.S.C. 2(b)(2); (2) furnishing of the information solicited is voluntary; and (3) the principal purpose for which the information is used by the U.S. Patent and Trademark Office is to process and/or examine your submission related to a patent application or patent. If you do not furnish the requested information, the U.S. Patent and Trademark Office may not be able to process and/or examine your submission, which may result in termination of proceedings or abandonment of the application or expiration of the patent.

The information provided by you in this form will be subject to the following routine uses:

1. The information on this form will be treated confidentially to the extent allowed under the Freedom of Information Act (5 U.S.C. 552) and the Privacy Act (5 U.S.C. 552a). Records from this system of records may be disclosed to the Department of Justice to determine whether disclosure of these records is required by the Freedom of Information Act.
2. A record from this system of records may be disclosed, as a routine use, in the course of presenting evidence to a court, magistrate, or administrative tribunal, including disclosures to opposing counsel in the course of settlement negotiations.
3. A record in this system of records may be disclosed, as a routine use, to a Member of Congress submitting a request involving an individual, to whom the record pertains, when the individual has requested assistance from the Member with respect to the subject matter of the record.
4. A record in this system of records may be disclosed, as a routine use, to a contractor of the Agency having need for the information in order to perform a contract. Recipients of information shall be required to comply with the requirements of the Privacy Act of 1974, as amended, pursuant to 5 U.S.C. 552a(m).
5. A record related to an International Application filed under the Patent Cooperation Treaty in this system of records may be disclosed, as a routine use, to the International Bureau of the World Intellectual Property Organization, pursuant to the Patent Cooperation Treaty.
6. A record in this system of records may be disclosed, as a routine use, to another federal agency for purposes of National Security review (35 U.S.C. 181) and for review pursuant to the Atomic Energy Act (42 U.S.C. 218(c)).
7. A record from this system of records may be disclosed, as a routine use, to the Administrator, General Services, or his/her designee, during an inspection of records conducted by GSA as part of that agency's responsibility to recommend improvements in records management practices and programs, under authority of 44 U.S.C. 2904 and 2906. Such disclosure shall be made in accordance with the GSA regulations governing inspection of records for this purpose, and any other relevant (*i.e.*, GSA or Commerce) directive. Such disclosure shall not be used to make determinations about individuals.
8. A record from this system of records may be disclosed, as a routine use, to the public after either publication of the application pursuant to 35 U.S.C. 122(b) or issuance of a patent pursuant to 35 U.S.C. 151. Further, a record may be disclosed, subject to the limitations of 37 CFR 1.14, as a routine use, to the public if the record was filed in an application which became abandoned or in which the proceedings were terminated and which application is referenced by either a published application, an application open to public inspection or an issued patent.
9. A record from this system of records may be disclosed, as a routine use, to a Federal, State, or local law enforcement agency, if the USPTO becomes aware of a violation or potential violation of law or regulation.

## SCORE Placeholder Sheet for IFW Content

Application Number: 14987707

Document Date: 01/04/2016

The presence of this form in the IFW record indicates that the following document type was received in electronic format on the date identified above. This content is stored in the SCORE database.

- Drawings – Other than Black and White Line Drawings

Since this was an electronic submission, there is no physical artifact folder, no artifact folder is recorded in PALM, and no paper documents or physical media exist. The TIFF images in the IFW record were created from the original documents that are stored in SCORE.

To access the documents in the SCORE database, refer to instructions below.

At the time of document entry (noted above):

- Examiners may access SCORE content via the eDAN interface.
- Other USPTO employees can bookmark the current SCORE URL (<http://Score.uspto.gov/ScoreAccessWeb/>).
- External customers may access SCORE content via the Public and Private PAIR interfaces.



UNITED STATES PATENT AND TRADEMARK OFFICE

UNITED STATES DEPARTMENT OF COMMERCE
United States Patent and Trademark Office
Address: COMMISSIONER FOR PATENTS
P.O. Box 1450
Alexandria, Virginia 22313-1450
www.uspto.gov

Table with 7 columns: APPLICATION NUMBER, FILING or 371(c) DATE, GRP ART UNIT, FIL FEE REC'D, ATTY. DOCKET NO, TOT CLAIMS, IND CLAIMS. Row 1: 14/987,707, 01/04/2016, 2684, 1340, MCROP0102USH, 30, 4

CONFIRMATION NO. 7143

FILING RECEIPT



130163
LUIS A. CARRION
RENNER, OTTO, BOISSELLE & SKLAR, LLP
1621 EUCLID AVENUE
19TH FLOOR
CLEVELAND, OH 44115

Date Mailed: 01/20/2016

Receipt is acknowledged of this non-provisional patent application. The application will be taken up for examination in due course. Applicant will be notified as to the results of the examination. Any correspondence concerning the application must include the following identification information: the U.S. APPLICATION NUMBER, FILING DATE, NAME OF APPLICANT, and TITLE OF INVENTION. Fees transmitted by check or draft are subject to collection. Please verify the accuracy of the data presented on this receipt. If an error is noted on this Filing Receipt, please submit a written request for a Filing Receipt Correction. Please provide a copy of this Filing Receipt with the changes noted thereon. If you received a "Notice to File Missing Parts" for this application, please submit any corrections to this Filing Receipt with your reply to the Notice. When the USPTO processes the reply to the Notice, the USPTO will generate another Filing Receipt incorporating the requested corrections

Inventor(s) Bennett H. Adelson, Highland Heights, OH;

Applicant(s) MacroPoint LLC, Cleveland, OH;

Power of Attorney: The patent practitioners associated with Customer Number 130163

Domestic Priority data as claimed by applicant
This application is a CON of 14/752,005 06/26/2015
which is a CON of 14/661,774 03/18/2015 PAT 9087313
which is a CON of 14/069,364 10/31/2013 PAT 9070295
which is a CON of 13/613,321 09/13/2012 PAT 8604943
which is a CON of 13/429,618 03/26/2012 PAT 8330626

Foreign Applications for which priority is claimed (You may be eligible to benefit from the Patent Prosecution Highway program at the USPTO. Please see http://www.uspto.gov for more information.) - None. Foreign application information must be provided in an Application Data Sheet in order to constitute a claim to foreign priority. See 37 CFR 1.55 and 1.76.

Permission to Access Application via Priority Document Exchange: Yes

Permission to Access Search Results: Yes

Applicant may provide or rescind an authorization for access using Form PTO/SB/39 or Form PTO/SB/69 as appropriate.

**If Required, Foreign Filing License Granted:** 01/19/2016

The country code and number of your priority application, to be used for filing abroad under the Paris Convention, is **US 14/987,707**

**Projected Publication Date:** Request for Non-Publication Acknowledged

**Non-Publication Request:** Yes

**Early Publication Request:** No

**\*\* SMALL ENTITY \*\***

**Title**

MACHINE OR GROUP OF MACHINES FOR MONITORING LOCATION OF A VEHICLE OR FREIGHT CARRIED BY A VEHICLE

**Preliminary Class**

340

**Statement under 37 CFR 1.55 or 1.78 for AIA (First Inventor to File) Transition Applications:** No

### **PROTECTING YOUR INVENTION OUTSIDE THE UNITED STATES**

Since the rights granted by a U.S. patent extend only throughout the territory of the United States and have no effect in a foreign country, an inventor who wishes patent protection in another country must apply for a patent in a specific country or in regional patent offices. Applicants may wish to consider the filing of an international application under the Patent Cooperation Treaty (PCT). An international (PCT) application generally has the same effect as a regular national patent application in each PCT-member country. The PCT process **simplifies** the filing of patent applications on the same invention in member countries, but **does not result** in a grant of "an international patent" and does not eliminate the need of applicants to file additional documents and fees in countries where patent protection is desired.

Almost every country has its own patent law, and a person desiring a patent in a particular country must make an application for patent in that country in accordance with its particular laws. Since the laws of many countries differ in various respects from the patent law of the United States, applicants are advised to seek guidance from specific foreign countries to ensure that patent rights are not lost prematurely.

Applicants also are advised that in the case of inventions made in the United States, the Director of the USPTO must issue a license before applicants can apply for a patent in a foreign country. The filing of a U.S. patent application serves as a request for a foreign filing license. The application's filing receipt contains further information and guidance as to the status of applicant's license for foreign filing.

Applicants may wish to consult the USPTO booklet, "General Information Concerning Patents" (specifically, the section entitled "Treaties and Foreign Patents") for more information on timeframes and deadlines for filing foreign patent applications. The guide is available either by contacting the USPTO Contact Center at 800-786-9199, or it can be viewed on the USPTO website at <http://www.uspto.gov/web/offices/pac/doc/general/index.html>.

For information on preventing theft of your intellectual property (patents, trademarks and copyrights), you may wish to consult the U.S. Government website, <http://www.stopfakes.gov>. Part of a Department of Commerce initiative, this website includes self-help "toolkits" giving innovators guidance on how to protect intellectual property in specific countries such as China, Korea and Mexico. For questions regarding patent enforcement issues, applicants may call the U.S. Government hotline at 1-866-999-HALT (1-866-999-4258).

**LICENSE FOR FOREIGN FILING UNDER**  
**Title 35, United States Code, Section 184**  
**Title 37, Code of Federal Regulations, 5.11 & 5.15**

**GRANTED**

The applicant has been granted a license under 35 U.S.C. 184, if the phrase "IF REQUIRED, FOREIGN FILING LICENSE GRANTED" followed by a date appears on this form. Such licenses are issued in all applications where the conditions for issuance of a license have been met, regardless of whether or not a license may be required as set forth in 37 CFR 5.15. The scope and limitations of this license are set forth in 37 CFR 5.15(a) unless an earlier license has been issued under 37 CFR 5.15(b). The license is subject to revocation upon written notification. The date indicated is the effective date of the license, unless an earlier license of similar scope has been granted under 37 CFR 5.13 or 5.14.

This license is to be retained by the licensee and may be used at any time on or after the effective date thereof unless it is revoked. This license is automatically transferred to any related applications(s) filed under 37 CFR 1.53(d). This license is not retroactive.

The grant of a license does not in any way lessen the responsibility of a licensee for the security of the subject matter as imposed by any Government contract or the provisions of existing laws relating to espionage and the national security or the export of technical data. Licensees should apprise themselves of current regulations especially with respect to certain countries, of other agencies, particularly the Office of Defense Trade Controls, Department of State (with respect to Arms, Munitions and Implements of War (22 CFR 121-128)); the Bureau of Industry and Security, Department of Commerce (15 CFR parts 730-774); the Office of Foreign Assets Control, Department of Treasury (31 CFR Parts 500+) and the Department of Energy.

**NOT GRANTED**

No license under 35 U.S.C. 184 has been granted at this time, if the phrase "IF REQUIRED, FOREIGN FILING LICENSE GRANTED" DOES NOT appear on this form. Applicant may still petition for a license under 37 CFR 5.12, if a license is desired before the expiration of 6 months from the filing date of the application. If 6 months has lapsed from the filing date of this application and the licensee has not received any indication of a secrecy order under 35 U.S.C. 181, the licensee may foreign file the application pursuant to 37 CFR 5.15(b).

---

***SelectUSA***

The United States represents the largest, most dynamic marketplace in the world and is an unparalleled location for business investment, innovation, and commercialization of new technologies. The U.S. offers tremendous resources and advantages for those who invest and manufacture goods here. Through SelectUSA, our nation works to promote and facilitate business investment. SelectUSA provides information assistance to the international investor community; serves as an ombudsman for existing and potential investors; advocates on behalf of U.S. cities, states, and regions competing for global investment; and counsels U.S. economic development organizations on investment attraction best practices. To learn more about why the United States is the best country in the world to develop technology, manufacture products, deliver services, and grow your business, visit <http://www.SelectUSA.gov> or call +1-202-482-6800.

**PATENT APPLICATION FEE DETERMINATION RECORD**

Substitute for Form PTO-875

Application or Docket Number  
14/987,707

**APPLICATION AS FILED - PART I**

(Column 1) (Column 2)

FOR	NUMBER FILED	NUMBER EXTRA
BASIC FEE (37 CFR 1.16(a), (b), or (c))	N/A	N/A
SEARCH FEE (37 CFR 1.16(k), (l), or (m))	N/A	N/A
EXAMINATION FEE (37 CFR 1.16(o), (p), or (q))	N/A	N/A
TOTAL CLAIMS (37 CFR 1.16(j))	30 minus 20 = *	10
INDEPENDENT CLAIMS (37 CFR 1.16(h))	4 minus 3 = *	1
APPLICATION SIZE FEE (37 CFR 1.16(s))	If the specification and drawings exceed 100 sheets of paper, the application size fee due is \$310 (\$155 for small entity) for each additional 50 sheets or fraction thereof. See 35 U.S.C. 41(a)(1)(G) and 37 CFR 1.16(s).	
MULTIPLE DEPENDENT CLAIM PRESENT (37 CFR 1.16(j))		

\* If the difference in column 1 is less than zero, enter "0" in column 2.

**SMALL ENTITY**

RATE(\$)	FEE(\$)
N/A	70
N/A	300
N/A	360
x 40 =	400
x 210 =	210
	0.00
	0.00
<b>TOTAL</b>	<b>1340</b>

**OR OTHER THAN SMALL ENTITY**

RATE(\$)	FEE(\$)
N/A	
N/A	
N/A	
<b>TOTAL</b>	

**APPLICATION AS AMENDED - PART II**

(Column 1) (Column 2) (Column 3)

AMENDMENT A		CLAIMS REMAINING AFTER AMENDMENT		HIGHEST NUMBER PREVIOUSLY PAID FOR	PRESENT EXTRA
	Total (37 CFR 1.16(i))	*	Minus	**	=
	Independent (37 CFR 1.16(h))	*	Minus	***	=
	Application Size Fee (37 CFR 1.16(s))				
FIRST PRESENTATION OF MULTIPLE DEPENDENT CLAIM (37 CFR 1.16(j))					

**SMALL ENTITY**

RATE(\$)	ADDITIONAL FEE(\$)
x =	
x =	
<b>TOTAL ADD'L FEE</b>	

**OR OTHER THAN SMALL ENTITY**

RATE(\$)	ADDITIONAL FEE(\$)
x =	
x =	
<b>TOTAL ADD'L FEE</b>	

(Column 1) (Column 2) (Column 3)

AMENDMENT B		CLAIMS REMAINING AFTER AMENDMENT		HIGHEST NUMBER PREVIOUSLY PAID FOR	PRESENT EXTRA
	Total (37 CFR 1.16(i))	*	Minus	**	=
	Independent (37 CFR 1.16(h))	*	Minus	***	=
	Application Size Fee (37 CFR 1.16(s))				
FIRST PRESENTATION OF MULTIPLE DEPENDENT CLAIM (37 CFR 1.16(j))					

**SMALL ENTITY**

RATE(\$)	ADDITIONAL FEE(\$)
x =	
x =	
<b>TOTAL ADD'L FEE</b>	

**OR OTHER THAN SMALL ENTITY**

RATE(\$)	ADDITIONAL FEE(\$)
x =	
x =	
<b>TOTAL ADD'L FEE</b>	

\* If the entry in column 1 is less than the entry in column 2, write "0" in column 3.  
 \*\* If the "Highest Number Previously Paid For" IN THIS SPACE is less than 20, enter "20".  
 \*\*\* If the "Highest Number Previously Paid For" IN THIS SPACE is less than 3, enter "3".  
 The "Highest Number Previously Paid For" (Total or Independent) is the highest found in the appropriate box in column 1.

2-2-16

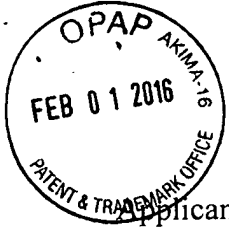

UNITED STATES PATENT AND TRADEMARK OFFICE

Applicant:	Bennett H. Adelson	Art Unit:	2682
Application No.	<del>14/978,707</del> 14/987,707	Examiner:	Mark S. Rushing
Filing Date:	January 4, 2016	Status/Location:	Pending
Title:	Unknown		

OK to  
Enter  
Protest  
M.H.  
3/17/16

Commissioner for Patents  
Attn.: Technology Center 2600  
P.O. Box 1450  
Alexandria, VA 22313-1450

January 27, 2016

**PROTEST UNDER 37 C.F.R. § 1.291**

In accordance with 37 C.F.R. § 1.291, submitted herewith for the Office's consideration is an information list comprising a listing of patents, publications, and other information relied upon set forth on Form PTO/SB/08A and 08B. These references are believed to be relevant to the above-referenced application. A concise explanation of the relevance of each listed item and a copy of each listed item identified in the attached form is also submitted herewith.

This Protest is the first protest submitted in this application by the real party in interest who is submitting the protest. In addition, the undersigned states that this Protest complies with 37 C.F.R. § 1.291.

This Protest has been served upon the Applicant in accordance with 37 C.F.R. § 1.248 by sending a copy of this Protest to the Applicant's representative that is listed for the parent application of the instant application, Appl. No. 13/613,321. The Protest has been transmitted by first class mail to Renner Otto Boisselle & Sklar, LLP, 1621 Euclid Avenue Nineteenth Floor Cleveland OH 44115 on January 27, 2016.

*Concise Explanation of References*

- (1) MacroPoint, LLC, v. FourKites, Memorandum of Opinion and Order dated November 6, 2015 (“Memorandum Opinion”)

On November 6, 2015, Judge Patricia A. Gaughan of the United States District Court for the Northern District of Ohio found all claims of U.S. Patent Nos. 8,604,943, 9,070,295, 9,082,097, 9,082,098, and 9,087,313 to be invalid under 35 U.S.C. § 101 as set forth in the Memorandum Opinion. The instant application claims priority to 13/613,621, which became U.S. Patent No. 8,604,943, all claims of which were found to be invalid.

The Memorandum Opinion is relevant because the applicant’s invention is for an abstract idea without the addition of an inventive concept.

- (2) Plaintiff MacroPoint, LLC’s Opposition to Defendant FourKites, Inc.’s Motion to Dismiss First Amended Complaint (“Opposition”)

MacroPoint, LLC sued FourKites, Inc. for infringement of U.S. Patent Nos. 8,604,943, 9,070,295, 9,082,097, 9,082,098, and 9,087,313. Applicant was the named inventor of each of the patents-in-suit, and MacroPoint, LLC was applicant’s assignee of each of the patents-in-suit. The instant application claims priority to 13/613,621, which became U.S. Patent No. 8,604,943. On information and belief, MacroPoint, LLC is the assignee of the instant application.

FourKites, Inc. moved to dismiss MacroPoint, LLC’s first amended complaint on the grounds that all of the claims of the patents-in-suit were invalid under 35 U.S.C. § 101. On September 15, 2015, MacroPoint, LLC filed its brief in opposition, wherein MacroPoint, LLC argued that the patents-in-suit were directed to an “open system” (as opposed to “closed systems” alleged to exist previously) for tracking vehicles and freight that requires a “new network architecture.” (Opposition, p. 5-7). The specification of U.S. Patent No. 8,604,943, of which the instant application is a continuation, is entirely silent as to and thus does not teach or support closed systems, an open systems, or network architectures.



Opposition is relevant because it demonstrates applicant's interpretation of the scope of applicant's invention is not adequately described and enabled by the specification in violation of 35 U.S.C. § 112, ¶ 1.

- (3) Declaration of Ivan Zatkovich in Support of MacroPoint, LLC's Opposition Brief to Defendant FourKites, Inc.'s Motion to Dismiss First Amended Complaint ("Zatkovich")

In support of Opposition (discussed above), MacroPoint LLC tendered Zatkovich, a report commissioned by MacroPoint that purports to explain why the applicant's invention is not for an abstract idea, or that it includes the addition of an inventive concept. Zatkovich describes the applicant's invention as directed to an "open system" that "enables heterogeneous locating technology," "enables continuous monitoring," and that "is a hub network with multi-channel communication." (Zatkovich, p. 29-30). The specification of U.S. Patent No. 8,604,943, of which the instant application is a continuation, is entirely silent as to and thus does not teach or support open systems, heterogeneous locating technology, continuous monitoring, or a hub network with multi-channel communication.

Zatkovich is relevant because it demonstrates applicant's interpretation of the scope of applicant's invention is not adequately described and enabled by the specification in violation of 35 U.S.C. § 112, ¶ 1.

- (4) Location-enhanced Call Center and IVR Services, Technical Insights About Your Calling Customer's Location ("TechnoCom White Paper"), 2009

TechnoCom White Paper "provides background to readers not completely familiar with wireless location technologies, their relative accuracies, and the implications to caller assistance and other contact center solutions." (TechnoCom White Paper, p. 1). The TechnoCom White paper explains that "[t]he call center or IVR system can obtain the caller's location" using "Computed Wireless Location – geometric computations of caller location using wireless signal measurements such as those received from GPS satellites or wireless network base stations. In some cases, the resulting location may be limited to a predetermined area such as that defined by the signal coverage of a cell site or sector." (TechnoCom White Paper, p. 3).

“Computed locations of varying accuracy can be determined by measuring and processing signals received by mobile telephones from global positioning system (GPS) satellites or cell towers in wireless networks. The ability to locate mobile phones became common in the U.S. in the late 1990’s after being mandated by the U.S. government for enhanced wireless services.” (TechnoCom White Paper, p. 5).

“The current rules for mobile telephone location privacy are based on two key precepts: the caller’s permission must be explicitly requested and granted before his/her location may be obtained; and the caller must be clearly informed of the intended use of the location information. The caller’s consent may be obtained temporarily for a one-time use or persistently for recurring uses. In the latter case, the caller must be periodically reminded that he/she has granted consent to be located and informed of the means by which he/she may revoke their consent.” (TechnoCom White Paper, p. 7).

The TechnoCom White Paper is relevant because it is prior art that anticipates and/or renders obvious the applicant’s invention.

(5) U.S. Patent No. 8,301,158 (“Thomas”)

Thomas is based on U.S. Appl. No. 12/150,126 filed April 26, 2008, which claims priority from U.S. Patent No. 7,366,522 and Provisional Application No. 60/185,480 filed February 28, 2000. Thomas is directed to location tracking of computing or communication devices. (Thomas, 1:20-23). Thomas describes a location monitoring system that manages location information pertaining to a plurality of mobile units. (Thomas, 3:64-68). The mobile units may be attached to objects such as people, vehicles, or containers. (Thomas, 3:68-4:2). A wireless network enables the mobile units to communicate with a location monitor server and the wireless network is coupled to the Internet. Location information associated with the mobile units is delivered to the location monitoring server through the wireless network and the Internet. (Thomas, 4:6-9). Each mobile unit can obtain location information on its location and forward the location information to the location monitoring server using a variety of methods including a global positioning satellite (GPS) device within the mobile unit. (Thomas, 4:28-31). Another method is to use location information from a wireless network. The wireless network can provide location information on some or all of the mobile units. (Thomas, 4:37-41).

Thomas further describes determining whether a notification is needed to send notifications to mobile units. Based on the location of the mobile communication device, various notifications can be initiated including an alert of a predetermined location, an alert of an unauthorized region, an alert of a change in location, and others. The notification can be sent through an email message, an instant response web-based message, through a web page provided at the mobile computing device, a telephone message, and others. (Thomas, 7:14-37).

Thomas additionally describes that the invention is suitable for tracking delivery or maintenance personnel or vehicles. When a delivery or service appointment is made, you can receive a code for the truck or person that is going to perform the delivery or service. Then, on the delivery day when the truck or person is to deliver to or service one's home or business, an alert message or notification can be sent. (Thomas at 10:3-10).

Thomas is relevant because it is prior art that anticipates and/or renders obvious the applicant's invention.

(6) U.S. Patent No. 8,755,823 ("Proietti")

Proietti was filed on February 15, 2011. Proietti is directed to a method and system for reporting a location of an asset. (Proietti, Abstract, 1:40-43). The method includes receiving a location tracking request for the asset, dynamically determining a status of the asset, and allowing acquisition of the location of the asset based on the determined status. The method further includes reporting the obtained location of the asset. (Proietti, 1:44-50).

Proietti discloses that radiolocation of mobile devices developed in the last half of the 20<sup>th</sup> century with the deployment of the Global Positioning System (GPS). (Proietti, 2:13-15). By the turn of the century, US cellular carriers deployed location-determination technology in their networks in support of emergency (E9-1-1) services. (Proietti, 2:15-18). Subsequently, with the widespread use of smart phones and other portable computing devices, numerous applications utilizing location have been made available for such uses as direction finding, tracking individuals, and matching persons with nearby businesses. (Proietti, 2:19-23). Traditionally, a company might monitor its resources, e.g., vehicles, through an expensive specialized tracking system. (Proietti, 2:24-25). With location technology being integrated into

employees' personal communication equipment (cell phones), the specialized tracking systems may no longer be needed. (Proietti, 2:26-28). The employer can track the employees via their cell phones. (Proietti, 2:28-29).

Proietti refers to a typical employee tracking system that monitors an employee using a tracking module using a cellular network. The tracking module provides employee locations to a reporting module that makes the locations available to an employer. An example of this is a cell phone tracking feature provided by a cellular carrier. The employer pays for the employee cell phone usage and has permission to monitor employee location while the employee is working. (Proietti, 2:32-43).

Proietti describes a system for tracking an asset monitored by a tracking module that provides assets locations to a reporting module. The asset may be an employee. The reporting module provides the location of the asset based on conditions set by a user. (Proietti, 2:60-67). For example, a status monitor module has a third state that could indicate a person's or an asset's eligibility for tracking only with a positive response to an explicit request for permission to be located. So, in this case while a user has given permission to be located during a particular period of time, their consent may be granted by the user on a case-by-case basis based on the requestor of the location or their current status during the authorized timeframe, but automatically denied if outside the authorized timeframe. (Proietti, 3:16-36). A long haul delivery vehicle might need only the less expensive/less accurate tracking while on the open road, but require more precise tracking near the terminus points. (Proietti, 3:45-48).

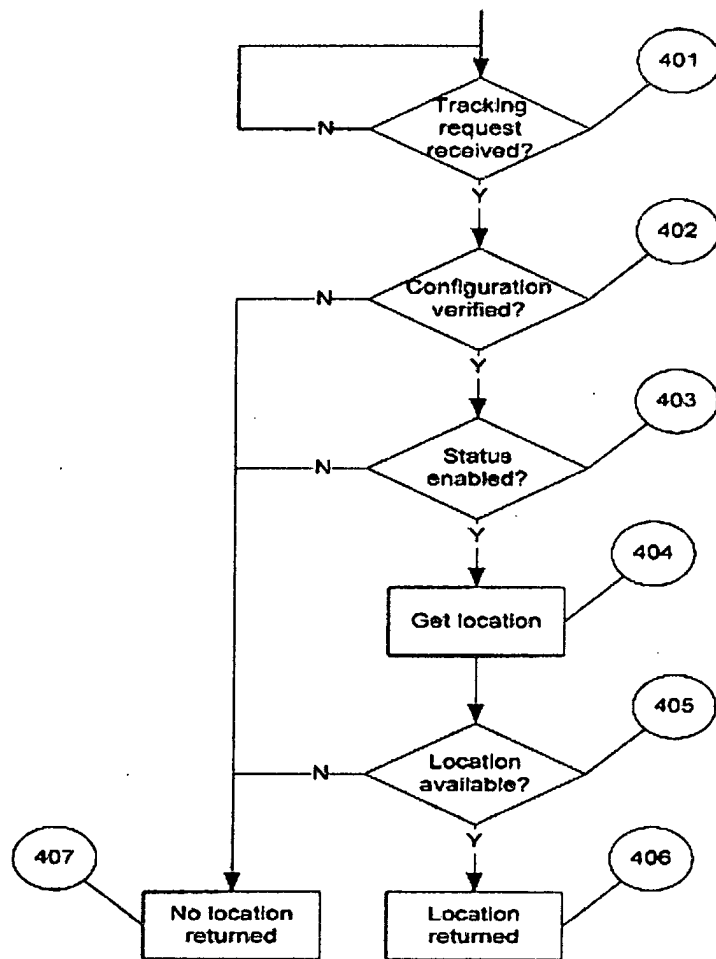

FIG. 4

As shown in Figure 4 of Proietti, the reporting module waits for a tracking request to be received from a status monitor module. When a request is received, the configuration is optionally checked to verify the status monitor module's credentials, verify the identity of the tracked person or asset, etc. (Proietti, 4:1-8). If the configuration verification fails, no location is returned, but if the configuration verification is successful, a status enablement check is performed. (Proietti, 4:8-12). The enablement state is determined by the status monitor module and the enablement module is checked to see if tracking is currently allowed, and any associated constraints. (Proietti, 4:12-14). If tracking is not allowed, no location is returned. (Proietti, 4:14-16). If tracking is allowed, then an attempt is made to locate the asset via the tracking

module. (Proietti, 4:17-18). If the location is not available, no location is returned. (Proietti, 4:18-19). If the location is available, the location is returned. (Proietti, 4:19-20). The allowance of the tracking may be stored for a next tracking request of the person or the asset. (Proietti, 4:20-22).

Proietti is relevant because it is prior art that anticipates and/or renders obvious the applicant's invention.

(7) U.S. Patent Application Publication No. 2009/0030770 ("Hersh")

Hersh discloses a dynamic and predictive information system and method for assigning shipping assets to goods subject to transport orders. (Hersh at [0003]). The system assigns shipping assets (drivers, tractors and trailers) from a plurality of carriers to enable the shipment of goods subject to a plurality of transport orders from a plurality of shippers. (Hersh at [0012]). A central computer maintains the database with data representing shipping assets wherein each carrier has at least one terminal from which respective shipping assets originate, respective service areas or regions, pricing schedules and, in some instances, lane routes (specially designated routes) which are often traveled by truck combinations of a particular carrier. (Hersh at [0012]). With the use of global positioning system (GPS) units and personal data assistant (PDAs) carried and removably mounted in the tractors used by drivers, the electronic information system can monitor the location of the trailer, the driver and also handle electronic copies of the electronic shipping documents (bills of lading, warehousing documents, customs documents, etc.). (Hersh at [0012]). This GPS data and electronic document data is associated with the transport order such that the carrier and the shipper and the customer having an interest in the goods under transport can see and view the electronic document and whereabouts of the goods or load. (Hersh at [0012]).

Hersh is relevant because it is prior art that anticipates and/or renders obvious the applicant's invention.

(8) U.S. Patent No. 8,649,775 ("Alessio")

Alessio was filed on December 28, 2008 and claims priority to Provisional Application No. 61/017,497 filed December 28, 2007. Alessio discloses a method of gathering

location information associated with a wireless device, terminal and/or phone. (Alessio at 2:54-56). A call is initiated between a wireless terminal and a remote tracking system and a location of the wireless terminal is determined. The determination may be done at the wireless terminal using information associated with the cellular infrastructure if the wireless terminal is a cellular phone, GPS information if the wireless terminal is GPS enabled, or location information associated with an IP address when the wireless terminal is a VoIP or WLAN type device. (Alessio at 2:56-64). The location information is transmitted to the remote tracking system during the call and stored with a time stamp at the remote tracking system. This information is associated with other information including shipment information. (Alessio at 2:67-3:7).

Alessio further discloses that a user (the driver or delivery person), using his/her cellphone may call or receive a call from a dedicated and remotely hosted phone number. (Alessio at 8:40-43). The driver selects from a telephone voice menu the type of event the driver is reporting, for example, a delivery. (Alessio at 8:43-45). The driver types into the phone the numeric digits that identify the freight or load being delivered if not known already by the application. (Alessio at 8:45-48). The application software of the remote tracking server generates a computerized record with the shipment number, the exact time stamp of the event, the client/shipper ID, the load ID, the event type, and the voice recording for the event. (Alessio at 8:55-59). A voice recording is transformed by the remote tracking server into readable and printable text that in conjunction with parameters including telephone Caller ID, physical location, and GPS location provides immediate visibility and tracking of the whereabouts of the freight and any events associated with the shipment of the freight and the freight's delivery route. (Alessio at 8:63-9:3). Figure 2 illustrates that the goods associated with a shipment may be transported via a delivery network using air, sea or land vehicles such as trucks to a destination location. (Alessio at 8:4-7, Figure 2, 112)

Alessio is relevant because it is prior art that anticipates and/or renders obvious the applicant's invention.

(9) Haulcom

Haulcom is an Android application that was available in the Google Play store on or before November 30, 2011. Haulcom was updated on November 30, 2011 as version 1.11.

After opening the Haulcom application on a mobile computing device, the mobile computing device displays a first user interface that requests a load number and a phone number. In one example, the load number is assigned to a particular shipment. After entering a load number and a particular phone number, the Haulcom application displays a second user interface. This second user interface is a message representing a notice communicating to a user of the mobile computing device that location information of the mobile computing device will be obtained. After confirming to disclose the location of the mobile computing device, at a particular interval of time, the mobile computing device automatically provides its location. In one example, the mobile computing device sends its location every 180 minutes.

Haulcom is relevant because it is prior art that anticipates and/or renders obvious the applicant's invention.

(10) FollowMee GPS Tracker ("FollowMee")

FollowMee is an iPhone application that was available for download on October 10, 2010. The application converts a mobile device into a GPS tracking device that quietly records a location of the mobile device using GPS, WiFi, and cellular triangulation and uploads this information to a server. To monitor a location of a tracked device, a user may visit a website to follow whereabouts of children, family members, employees, company mobile devices, or a fleet. One of ordinary skill in the art would understand that before the application is able to track a trip, the user would have to provide permission for the application to obtain a location of the mobile device and select "Allow" in order for the application to obtain the location.

FollowMee is relevant because it is prior art that anticipates and/or renders obvious the applicant's invention.

(11) uFollowit

uFollowit is an iPhone application that provided real-time freight tracking. A user could enter a client number and a load number assigned by a shipper, broker, or dispatch office and the application instantly notifies stakeholders at the time of pick up, regular in-transit statuses all the way to capturing and distributing delivery location, consignee name and signature.



uFollow it is relevant because it is prior art that anticipates and/or renders obvious the applicant's invention.

(12) myGeoTracking

myGeoTracking is an enterprise tracking portal that leverages TechnoCom's Location Platform to provide location tracking of vehicles and freight. myGeoTracking permitted companies to determine the location of mobile assets and field personnel in real-time using a variety of telematics devices, as well as GPS phones (i.e., smart phones) and non-GPS phones (i.e., flip phones). myGeoTracking was available to the public and in use at least as early as March 2011.

myGeoTracking is relevant because it is prior art that anticipates and/or renders obvious the applicant's invention.

(13) MoosTrax

MoosTrax is an iPhone application that was available for download on July 29, 2010. MoosTrax sent the iPhone's location to a MoosTrax.com account. You can track your iPhone live, view location history, tag favorite locations, and setup GeoFence notifications from the website. One of ordinary skill in the art would understand that before the application is able to track a trip, the user would have to provide permission for the application to obtain a location of the mobile device and select "Allow" in order for the application to obtain the location.

MoosTrax is relevant because it is prior art that anticipates and/or renders obvious the applicant's invention.

(14) MileBug

MileBug is an application that was available on the iOS App Store on or before May 11, 2011. A user could use MileBug to add a new trip and select "GPS Tracking." The application would run in the background of iOS and track a trip. The trip was viewable on a map. One of ordinary skill in the art would understand that before the application is able to track a trip, the user would have to provide permission for the application to obtain a location of the mobile device and select "Allow" in order for the application to obtain the location.

MileBug is relevant because it is prior art that anticipates and/or renders obvious the applicant's invention.

(15) Enterprise

Enterprise discloses obtaining a location of a mobile caller with and without location capability. (Slide 6). The document indicates that for callers that have not opted-in to providing their location, on-demand consent may be sought by the interactive voice response (IVR) and granted by the caller. (Slide 9). For example, the IVR may provide the following message: "Thank you for calling...I can try to access your location from your wireless carrier to give you better service during this call. Your privacy is important to us so your location will not be shared with anyone without your approval. Is that OK?" (Slide 10). If the caller permits being located, the IVR asks the caller to wait and provides this message: "Please wait while I try to access your location..." (Slide 11).

In addition, the caller may be offered the opportunity to opt-in for persistent consent for faster service in the future. The IVR may provide the following message: "If you want to make your consent to locate permanent, I can SMS you a code to use during your next call. Do you want to do that at this time?" (Slide 11). If the caller has requested persistent opt-in for location, the IVR prompts the caller to enter the code during a next call. The IVR may provide the following message: "I see that you have been sent a location permission code. Would you like to enter the code now?" The IVR prompts the caller to enter the code by providing this message: "Please enter your four digit confirmation number." If the caller enters the correct code, the IVR provides confirmation that opt-in has been completed. (Slide 12).

Enterprise is relevant because it is prior art that anticipates and/or renders obvious the applicant's invention.

The Commissioner is hereby authorized to charge payment of any fees associated with this Protest to Deposit Account No. 50-1662.

Respectfully submitted,

POLSINELLI PC

Date: January 27, 2016

/John R. Bednarz/  
John R. Bednarz, Reg. No. 62,168  
900 W. 48<sup>th</sup> Place, Suite 900  
Kansas City, MO 64112  
(816) 360-4382

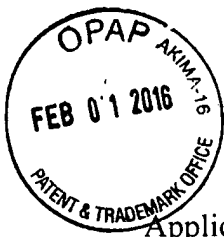

IN THE UNITED STATES PATENT AND TRADEMARK OFFICE

Application of:	Bennett H. Adelson	Art Unit:	2682
Application No.:	14/978,707	Conf. No.:	Unknown
Filing Date:	January 4, 2016	Examiner:	Mark S. Rushing
Title:	Unknown		

Commissioner for Patents  
Attn.: Technology Center 2600  
P.O. Box 1450  
Alexandria, VA 22313-1450

EXPRESS MAIL TRANSMITTAL

Transmitted herewith are: 1. Express Mail Transmittal (1 page); 2. Protest (13 pages); 3. IDS Transmittal (5 pages); 4. US, Foreign and NPL References (314 pages); 5. Certificate of Mailing (1 page); 6. Return Postcard (1 card).

EK 936660693 US  
Express Mail Mailing Label Number

Respectfully submitted,

POLSINELLI PC

Dated: January 27, 2016

By /John R. Bednarz/

John R. Bednarz, Reg. No. 62,168  
900 W. 48<sup>th</sup> Place, Suite 900  
Kansas City, MO 64112  
Phone: (816) 753-1000  
Email: [jbednarz@polsinelli.com](mailto:jbednarz@polsinelli.com)

ATTORNEYS FOR FOURKITES, INC.

Attny Docket No. 082473-495242

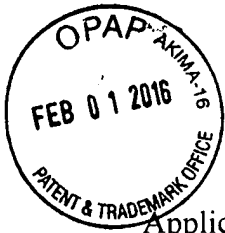

**IN THE UNITED STATES PATENT AND TRADEMARK OFFICE**

Application of:	Bennett H. Adelson	Art Unit:	2682
Application No.:	14/978,707	Conf. No.:	Unknown
Filing Date:	January 4, 2016	Examiner:	Mark S. Rushing
Title:	Unknown		

Commissioner for Patents  
 Attn.: Technology Center 2600  
 P.O. Box 1450  
 Alexandria, VA 22313-1450

**EXPRESS MAIL TRANSMITTAL**

Transmitted herewith are: 1. Express Mail Transmittal (1 page); 2. Protest (13 pages); 3. IDS Transmittal (5 pages); 4. US, Foreign and NPL References (314 pages); 5. Certificate of Mailing (1 page); 6. Return Postcard (1 card).

EK 936660693 US  
 Express Mail Mailing Label Number

Respectfully submitted,

POLSINELLI PC

Dated: January 27, 2016

By                   /John R. Bednarz/

John R. Bednarz, Reg. No. 62,168  
 900 W. 48<sup>th</sup> Place, Suite 900  
 Kansas City, MO 64112  
 Phone: (816) 753-1000  
 Email: [jbednarz@polsinelli.com](mailto:jbednarz@polsinelli.com)

ATTORNEYS FOR FOURKITES, INC.

Attny Docket No. 082473-495242

<b>INFORMATION DISCLOSURE STATEMENT BY APPLICANT</b> (Not for submission under 37 CFR 1.99)	Application Number		14978707	
	Filing Date		2016-01-04	
	First Named Inventor		Bennett H. Adelson	
	Art Unit		2682	
	Examiner Name		Mark S. Rushing	
	Attorney Docket Number		Unknown	

U.S.PATENTS						
Examiner Initial*	Cite No	Patent Number	Kind Code <sup>1</sup>	Issue Date	Name of Patentee or Applicant of cited Document	Pages, Columns, Lines where Relevant Passages or Relevant Figures Appear
	1	8301158	B1	2012-10-30	Thomas	
	2	8755823	B2	2014-06-17	Proietti et al.	
	3	8649775	B2	2014-02-11	Alessio et al.	

If you wish to add additional U.S. Patent citation information please click the Add button.

U.S.PATENT APPLICATION PUBLICATIONS						
Examiner Initial*	Cite No	Publication Number	Kind Code <sup>1</sup>	Publication Date	Name of Patentee or Applicant of cited Document	Pages, Columns, Lines where Relevant Passages or Relevant Figures Appear
	1	20090030770	A1	2009-01-29	Hersh et al.	

If you wish to add additional U.S. Published Application citation information please click the Add button.

FOREIGN PATENT DOCUMENTS								
Examiner Initial*	Cite No	Foreign Document Number <sup>3</sup>	Country Code <sup>2</sup>	Kind Code <sup>4</sup>	Publication Date	Name of Patentee or Applicant of cited Document	Pages, Columns, Lines where Relevant Passages or Relevant Figures Appear	T <sup>5</sup>
	1							<input type="checkbox"/>

**INFORMATION DISCLOSURE  
STATEMENT BY APPLICANT**  
(Not for submission under 37 CFR 1.99)

Application Number	14978707
Filing Date	2016-01-04
First Named Inventor	Bennett H. Adelson
Art Unit	2682
Examiner Name	Mark S. Rushing
Attorney Docket Number	Unknown

If you wish to add additional Foreign Patent Document citation information please click the Add button

**NON-PATENT LITERATURE DOCUMENTS**

Examiner Initials*	Cite No	Include name of the author (in CAPITAL LETTERS), title of the article (when appropriate), title of the item (book, magazine, journal, serial, symposium, catalog, etc), date, pages(s), volume-issue number(s), publisher, city and/or country where published.	T <sup>5</sup>
	1	GAUGHAN, Judge Patricia A.; Memorandum of Opinion and Order; MacroPoint, LLC v. FourKites, Inc.; USDC No. Dist. of OH; Case No. 1:15-CV-1002; 11/06/2015; 14 pages.	<input type="checkbox"/>
	2	PRIBISICH, Risto; Plaintiff MacroPoint, LLC's Opposition to Defendant FourKites, Inc.'s Motion to Dismiss First Amended Complaint; September 15, 2015; 38 pages.	<input type="checkbox"/>
	3	ZATKOVICH, Ivan; Declaration of Ivan Zatkovich in Support of MacroPoint, LLC's Opposition Brief to FourKites, Inc.'s Motion to Dismiss First Amended Complaint (Exhibit 3); September 15, 2015, 113 pages.	<input type="checkbox"/>
	4	TechnoCom Corporation; Location-enhanced Call Center and IVR Services: Technical Insights About Your Calling Customer's Location; TechnoCom Corporation, 2009; 7 pages.	<input type="checkbox"/>
	5	Android HaulCom Application Screen Shots and Description, November 30, 2011; 10 pages.	<input type="checkbox"/>
	6	FollowMee LLC; GPS Location Tracker for iPhone and iPad - Standard Edition, Released October 10, 2010 Description of application and screen shots, 4 pages	<input type="checkbox"/>
	7	uFollowit Application for iOS released October 12, 2009; Description of application and screen shots; 4 pages.	<input type="checkbox"/>
	8	Abaqus Blog; myGeoTracking: Asset Tracking & Monitoring Service; <a href="https://web.archive.org/web/20100819041357http://abaqus.typepad.com/">https://web.archive.org/web/20100819041357http://abaqus.typepad.com/</a> ; February 25, 2010; 7 pages.	<input type="checkbox"/>
	9	Tech9 Computer Solutions; MoosTrax Application for iOS released July 29, 2010; Description of application and screen shots; 2 pages.	<input type="checkbox"/>

**INFORMATION DISCLOSURE  
STATEMENT BY APPLICANT**  
(Not for submission under 37 CFR 1.99)

Application Number		14978707
Filing Date		2016-01-04
First Named Inventor	Bennett H. Adelson	
Art Unit	2682	
Examiner Name	Mark S. Rushing	
Attorney Docket Number	Unknown	

10	Izatt International; MileBug - Mileage Log & Expense Tracker for Deduction and application for iOS released May 10, 2011; Description of application and screen shots; 4 pages.	<input type="checkbox"/>
11	TechnoCom Corporation; Enterprise Location Platform: Sample IVR Privacy Management Script; TechoCom Corporation; April 16, 2010; 15 pages.	<input type="checkbox"/>

If you wish to add additional non-patent literature document citation information please click the Add button

**EXAMINER SIGNATURE**

Examiner Signature		Date Considered	
--------------------	--	-----------------	--

\*EXAMINER: Initial if reference considered, whether or not citation is in conformance with MPEP 609. Draw line through a citation if not in conformance and not considered. Include copy of this form with next communication to applicant.

<sup>1</sup>See Kind Codes of USPTO Patent Documents at [www.USPTO.GOV](http://www.USPTO.GOV) or MPEP 901.04. <sup>2</sup>Enter office that issued the document, by the two-letter code (WIPO Standard ST.3). <sup>3</sup>For Japanese patent documents, the indication of the year of the reign of the Emperor must precede the serial number of the patent document. <sup>4</sup>Kind of document by the appropriate symbols as indicated on the document under WIPO Standard ST.16 if possible. <sup>5</sup>Applicant is to place a check mark here if English language translation is attached.



**INFORMATION DISCLOSURE  
STATEMENT BY APPLICANT**  
(Not for submission under 37 CFR 1.99)

Application Number	14978707
Filing Date	2016-01-04
First Named Inventor	Bennett H. Adelson
Art Unit	2682
Examiner Name	Mark S. Rushing
Attorney Docket Number	Unknown

**CERTIFICATION STATEMENT**

Please see 37 CFR 1.97 and 1.98 to make the appropriate selection(s):

That each item of information contained in the information disclosure statement was first cited in any communication from a foreign patent office in a counterpart foreign application not more than three months prior to the filing of the information disclosure statement. See 37 CFR 1.97(e)(1).

OR

That no item of information contained in the information disclosure statement was cited in a communication from a foreign patent office in a counterpart foreign application, and, to the knowledge of the person signing the certification after making reasonable inquiry, no item of information contained in the information disclosure statement was known to any individual designated in 37 CFR 1.56(c) more than three months prior to the filing of the information disclosure statement. See 37 CFR 1.97(e)(2).

See attached certification statement.

The fee set forth in 37 CFR 1.17 (p) has been submitted herewith.

A certification statement is not submitted herewith.

**SIGNATURE**

A signature of the applicant or representative is required in accordance with CFR 1.33, 10.18. Please see CFR 1.4(d) for the form of the signature.

Signature	/John R. Bednarz/	Date (YYYY-MM-DD)	2016-01-27
Name/Print	John R. Bednarz	Registration Number	62168

This collection of information is required by 37 CFR 1.97 and 1.98. The information is required to obtain or retain a benefit by the public which is to file (and by the USPTO to process) an application. Confidentiality is governed by 35 U.S.C. 122 and 37 CFR 1.14. This collection is estimated to take 1 hour to complete, including gathering, preparing and submitting the completed application form to the USPTO. Time will vary depending upon the individual case. Any comments on the amount of time you require to complete this form and/or suggestions for reducing this burden, should be sent to the Chief Information Officer, U.S. Patent and Trademark Office, U.S. Department of Commerce, P.O. Box 1450, Alexandria, VA 22313-1450. DO NOT SEND FEES OR COMPLETED FORMS TO THIS ADDRESS. **SEND TO: Commissioner for Patents, P.O. Box 1450, Alexandria, VA 22313-1450.**

## Privacy Act Statement

The Privacy Act of 1974 (P.L. 93-579) requires that you be given certain information in connection with your submission of the attached form related to a patent application or patent. Accordingly, pursuant to the requirements of the Act, please be advised that: (1) the general authority for the collection of this information is 35 U.S.C. 2(b)(2); (2) furnishing of the information solicited is voluntary; and (3) the principal purpose for which the information is used by the U.S. Patent and Trademark Office is to process and/or examine your submission related to a patent application or patent. If you do not furnish the requested information, the U.S. Patent and Trademark Office may not be able to process and/or examine your submission, which may result in termination of proceedings or abandonment of the application or expiration of the patent.

The information provided by you in this form will be subject to the following routine uses:

1. The information on this form will be treated confidentially to the extent allowed under the Freedom of Information Act (5 U.S.C. 552) and the Privacy Act (5 U.S.C. 552a). Records from this system of records may be disclosed to the Department of Justice to determine whether the Freedom of Information Act requires disclosure of these records.
2. A record from this system of records may be disclosed, as a routine use, in the course of presenting evidence to a court, magistrate, or administrative tribunal, including disclosures to opposing counsel in the course of settlement negotiations.
3. A record in this system of records may be disclosed, as a routine use, to a Member of Congress submitting a request involving an individual, to whom the record pertains, when the individual has requested assistance from the Member respect to the subject matter of the record.
4. A record in this system of records may be disclosed, as a routine use, to a contractor of the Agency having need for the information in order to perform a contract. Recipients of information shall be required to comply with the requirements of the Privacy Act of 1974, as amended, pursuant to 5 U.S.C. 552a(m).
5. A record related to an International Application filed under the Patent Cooperation Treaty in this system of records may be disclosed, as a routine use, to the International Bureau of the World Intellectual Property Organization, pursuant to the Patent Cooperation Treaty.
6. A record in this system of records may be disclosed, as a routine use, to another federal agency for purposes of National Security review (35 U.S.C. 181) and for review pursuant to the Atomic Energy Act (42 U.S.C. 218(c)).
7. A record from this system of records may be disclosed, as a routine use, to the Administrator, General Services, or her designee, during an inspection of records conducted by GSA as part of that agency's responsibility to recommend improvements in records management practices and programs, under authority of 44 U.S.C. 2904 and 2906. Such disclosure shall be made in accordance with the GSA regulations governing inspection of records for this purpose, and any other relevant (i.e., GSA or Commerce) directive. Such disclosure shall not be used to make determinations about individuals.
8. A record from this system of records may be disclosed, as a routine use, to the public after either publication of the application pursuant to 35 U.S.C. 122(b) or issuance of a patent pursuant to 35 U.S.C. 151. Further, a record may be disclosed, subject to the limitations of 37 CFR 1.14, as a routine use, to the public if the record was filed in an application which became abandoned or in which the proceedings were terminated and which application is referenced by either a published application, an application open to public inspections or an issued patent.
9. A record from this system of records may be disclosed, as a routine use, to a Federal, State, or local law enforcement agency, if the USPTO becomes aware of a violation or potential violation of law or regulation.

# Memorandum Opinion

MacroPoint, LLC, v. FourKites,  
Memorandum of Opinion and  
Order dated November 6, 2015

UNITED STATES DISTRICT COURT  
NORTHERN DISTRICT OF OHIO  
EASTERN DIVISION

MacroPoint, LLC,	)	CASE NO. 1:15 CV 1002
	)	
Plaintiff,	)	JUDGE PATRICIA A. GAUGHAN
	)	
Vs.	)	
	)	
FourKites, Inc.,	)	<u>Memorandum of Opinion and Order</u>
	)	
Defendant.	)	

**INTRODUCTION**

This matter is before the Court upon Defendant FourKites, Inc.'s Motion to Dismiss First Amended Complaint for Failure to State a Claim Upon Which Relief Can Be Granted as a Matter of Law (Doc. 18). This is a patent infringement action. For the reasons that follow, the motion is GRANTED.

**FACTS**

Five patents are at issue in this lawsuit. The patents are directed at "a system for providing location information of a vehicle [that] includes a communications interface and a

correlation logic that correlates location information of a communications device to location of the vehicle.” Claim 1 in the ‘943 patent is representative of the claims of the patents-in-suit and provides as follows:<sup>1</sup>

A computer implemented method for indicating location of freight carried by a vehicle, the method comprising:

[a] correlating the freight to a communications device;

[b] receiving a first signal including data representing a request for information regarding the location of the freight;

[c] transmitting to the communications device a second signal including data that prompts an automated message to be communicated to a user of the communications device, the automated message representing a notice communicating to the user of the communications device that the location information of the communication device will be obtained;

[d] receiving from the communications device a third signal including data indicative of consent from the user to the obtaining of the location information of the communications device;

[e] transmitting a fourth signal to a location information provider, the fourth signal including data representing a request for location information of the communications device, wherein the location information provider corresponds to a party or device other than the communications device and the location information provider corresponds to at least one of:

[e][i] a wireless service provider providing wireless service to the communications device,

---

<sup>1</sup> Plaintiff does not dispute that Claim 1 is representative of the claims of the patents-in-suit. Plaintiff instead argues that defendant fails to address all of the 94 claims across all five patents-in-suit. Plaintiff is incorrect. If one claim is a representative claim, courts need not address each claim individually. *See, Content Extraction and Transmission, LLC v. Wells Fargo National Bank Association*, 776 F.3d 1343, 1348 (Fed. Cir. 2014); *In re TLI Communications*, 2015 WL 627858 at \*9 (Feb. 6, 2015).

[e][ii] a third party that obtains the location information of the communications device from the wireless service provider providing wireless service to the communications device, and

[e][iii] a party that has access to the location information of the communications device but is other than the wireless service provider or the third party that obtains the location information of the communications device from the wireless service provider;

[f] receiving a fifth signal from the location information provider, the fifth signal including data representing the location information of the communications device;

[g] correlating the location information of the communications device to the location of the freight based at least in part on the correlation between the freight and the communications device; and

[h] transmitting a sixth electronic signal including data representing the location of the freight.

The '943 patent issued on December 10, 2013. The remaining patents issued more than a year after the Supreme Court decided *Alice Corp. Pty. Ltd. v. CLS Bank International*, 134 S.Ct. 2347 (2014). Defendant moves to dismiss the case on the grounds that the patents-in-suit are invalid in light of *Alice*. Plaintiff opposes the motion.

### ANALYSIS

#### 1. Propriety of a motion to dismiss

As an initial matter, the Court finds that it is procedurally proper to address defendant's arguments concerning invalidity based on patent-eligibility at the 12(b)(6) stage. *See, Content Extraction and Transmission, LLC v. Wells Fargo National Bank Association*, 776 F.3d 1343 (Fed. Cir. 2014). This is especially so in light of the fact that plaintiff does not argue that claim construction is necessary for a resolution of the instant dispute. In addressing defendant's arguments, the Court will presume that the patents are valid and grant the motion only if defendant is able to show invalidity by clear and convincing evidence. Although post-*Alice*

courts appear to call into question whether a presumption of validity applies in this context, the Court will apply the presumption especially in light of the fact that the PTO issued four of the five patents-in-suit after the Supreme Court decided *Alice*. The Court will not, however, consider the expert affidavit offered by plaintiff as evidentiary matters outside of the complaint are not to be considered by a Court in addressing a motion under Rule 12. With these standards in mind, the Court turns to defendant's invalidity argument.<sup>2</sup>

## 2. *Alice*

Defendant asks that the Court declare the patents at issue invalid because they are drawn to an abstract idea. Pursuant to 35 U.S.C. § 101, “[w]hoever invents or discovers any new and useful process, machine, manufacture, or composition of matter, or any new and useful improvement thereof, may obtain a patent therefore....” Section 101 is limited, however, and does not cover “laws of nature, natural phenomena, and abstract ideas.” *Alice*, 134 S.Ct. at 2354. In “applying the § 101 exception, we must distinguish between patents that claim the ‘building block[s]’ of human ingenuity and those that integrate the building blocks into something more.” *Id.* (Citing *Mayo Collaborative Services, v. Prometheus Laboratories, Inc.*, 132 S.Ct. 1289, 1303 (2012)).

In *Alice*, the Supreme Court employed a two-part test “for distinguishing patents that

---

<sup>2</sup> Plaintiff relies heavily on the Court's decision in *Progressive Cas. Ins. Co. v. Safeco Ins. Co.*, in which this Court determined that invalidity should be addressed after claim construction. As an initial matter, the plaintiff in *Progressive* argued that claim construction was necessary for a resolution of the matter. Moreover, the Court decided that issue long before the wave of invalidity arguments made after recent Supreme Court and Federal Circuit decisions. Invalidity arguments based on patent-eligibility are now routinely addressed at the 12(b)(6) stage.

claim laws of nature, natural phenomena, and abstract ideas from those that claim patent-eligible applications of those concepts.” *Id.* at 2355. First, the court must determine “whether the claims at issue are directed at a patent-ineligible concept.” If the claims are so construed, the Courts must proceed to step two, which involves a determination as to whether the patent contains an “inventive concept,” which is described as “an element or combination of elements that is sufficient to ensure that the patent in practice amounts to significantly more than a patent upon the ineligible concept itself.” *Id.* (Internal citations and quotations omitted).

#### A. Patent-ineligible concept

Generally speaking, this prong addresses whether the patent is directed to an “abstract” idea because there is a longstanding rule that “an idea itself is not patentable.” *Id.* (Citations and quotations omitted). For this reason, patents describing algorithms and other mathematical formulas are invalid. In addition, patents involving general conceptual ideas are not patentable. *See, e.g., Alice*, 134 S.Ct. 2347 (patent directed at abstract idea of “intermediated settlement”) *Bilski v. Kappos*, 561 U.S. 593 (2010)(patent involved abstract idea of hedging); *Ultramercial, Inc. v. Hulu, LLC*, 772 F.3d 709 (Fed. Cir. 2014)(patent directed at the “use of an advertisement as a currency exchange” constituted abstract idea); *Wireless Media Innovations, LLC v. Maher Terminals, LLC*, 2015 WL 1810378 (D.N.J. April 20, 2015)(the “monitoring locations, movement, and load status of shipping containers within a container-receiving yard, and storing, reporting, and communicating this information” constitutes an “abstract idea.”).

Here, defendant claims that the patents involve the abstract idea of tracking freight. According to defendant, the patents involve basic concepts like “(1) receiving a request for the location of the freight; (2) asking the truck in possession of that freight where it is; and (3)



reporting the location of the truck.” Defendant argues that the claims simply “use” a computer to accomplish these tasks. Because the claims constitute nothing more than a “method of organizing prior-existing, basic human activity,” they are directed at an abstract idea.

In response, plaintiff argues that defendant does not accurately describe the patent. According to plaintiff, the patent does not “ask the truck” for its location. Rather, the freight is located through an indirect communication with a communication provider. Plaintiff argues that the patent is not directed to the general idea of tracking freight, but rather a specific way of tracking freight.

Upon review, the Court finds that the patents-in-suit are directed to the abstract idea of tracking freight. “Under step one of *Mayo/Alice*, the claims are considered in their entirety to ascertain whether their character as a whole is directed to excluded subject matter.” *Internet Patents Corp. v. Active Network, Inc.*, 790 F.3d 1343, 1346 (Fed. Cir. 2015). In determining whether an idea is abstract, courts are to ask “what the claim is trying to achieve, instead of examining the point of novelty.” *Enfish LLC v. Microsoft Corp.*, 56 F.Supp.3d 1167 (C.D. Cal. Nov. 3, 2014)(citing *Diamond v. Diehr*, 450 U.S. 175 (1981)). As such, “[c]ourts should recite a claim’s purpose at a reasonably high level of generality. Step one is sort of a ‘quick look’ test, the purpose of which is to identify a risk of preemption and ineligibility.” *Id.* Here, the claim discloses nothing more than a process for tracking freight, including monitoring, locating, and communicating regarding the location of the freight. These ideas are all abstract in and of themselves. *See, Wireless Media Innovations, LLC v. Maher Terminals, LLC*, —F.Supp.3d—, 2015 WL 1810378 (D. N.J. April 20, 2015)(process for tracking freight is an abstract idea).

Plaintiff argues that *Wireless Media* is distinguishable. According to plaintiff, the PTO

issued the patents in *Wireless Media* before the Supreme Court's decision in *Alice*. Contrary to plaintiff's argument, the fact that the PTO may have considered *Alice*-based guidelines before issuing the patents-in-suit does not *mandate* a finding that the patents are valid. Nor does the fact that *Wireless Media* involved a "local, closed, single-channel, discrete environment" as opposed to a "open system for multi-channel, real-time tracking of vehicles and freight nationwide" render the subject matter of the patents-in-suit something other than an abstract idea. Although plaintiff notes the difference, plaintiff fails to offer any explanation as to why this fact is relevant to this issue.

Plaintiff relies on *DDR Holdings, LLC v. Hotels.com L.P.*, 773 F.3d 1245 (Fed. Cir. 2014) in support of its position that the subject matter is not directed to an abstract idea. In *DDR Holdings*, the court examined a patent comprising "systems and methods of generating a composite web page that combines certain visual elements of a 'host' website with the content of a third-party merchant." *Id.* at 1248. In layman's terms, it appears that the patent allowed an internet retailer to publish content from a third-party retailer in order to avoid the situation in which a user clicks on an advertisement and is redirected away from the original retailer's site. The Federal Circuit concluded that the patent passed muster under Section 101 because it was "necessarily rooted in computer technology to overcome a problem specifically arising in the realm of computer networks." *Id.* at 1257. Although the court began its analysis by noting that the subject matter at issue involved a "challenge particular to the internet" that impliedly is not abstract, the court ultimately determined that "under any characterization of the abstract idea, the [ ] patent's claims satisfy *Mayo/Alice* step two." *Id.* Thus, the Court does not find that *DDR Holdings* controls with regard to step one of *Alice*.

Plaintiff also cites *Messaging Gateway Solutions, LLC v. Amdocs, Inc.*, 2015 WL 1744343 (D. Del. April 15, 2015). That case, however, actually supports defendant's position. Although ultimately the court determined that the patent contains an inventive concept at step two, the court found that a patent encompassing a "method of using a computer system to facilitate two-way communication between a mobile device and an Internet server" is directed at an abstract idea for purposes of step one. *See also, Content Extraction and Transmission LLC v. Wells Fargo Bank, N.A.*, 776 F.3d 1343 (Fed. Cir. 2014)(method patent directed at the extraction of data from hard copy documents, recognition of specific data, and storage of the data is directed at abstract idea); *Cyberfone Systems, LLC v. CNN Interactive Group, Inc.*, 558 Fed. Appx. 988 (Fed. Cir. 2014)(method patent whose steps require obtaining data, "exploding" data into parts, and sending data to different destinations directed at abstract concept); *MicroStrategy, Inc. v. Apttus Corp.*, 2015 WL 4425828, —F.Supp.3d— (E.D. Va. July 17, 2015)(patents for intelligent server system, method and system for providing business intelligence web content, and system and method for remote manipulation for analytic reports all directed to abstract ideas); *Market Track, LLC v. Efficient Collaborative Retail Marketing, LLC*, 2015 WL 3637740 (N.D. Ill. June 12, 2015)(method patent directed at creating output files from images did not satisfy part one of the *Alice* test).

In sum, the Court finds that the patent is directed at a method for tracking freight, which is an abstract concept. Having so concluded, the Court now turns to step two of the *Alice* test.

#### B. Inventive concept

At step two, this Court must determine whether the elements of the claim contain an "inventive concept sufficient to transform the claimed abstract idea into a patent-eligible

application.” In other words, the Court must determine whether the claim includes “additional features” such that the claim is “more than a drafting effort designed to monopolize the abstract idea.” *Alice*, 134 S.Ct. at 2357 (citations and quotations omitted). The “additional features” must be more than ‘well-understood, routine, conventional activity.’” *Ultramercial, Inc. v. Hulu, Inc.*, 772 F.3d 709, 715 (Fed. Cir. 2014)(quoting *Mayo Collaborative Services v. Prometheus Labs., Inc.*, 132 S.Ct. 1289, 1298 (2012)). Adding the words “apply it” or the mere introduction of a computer used to implement the abstract idea is insufficient to satisfy *Alice*’s second prong.

Plaintiff points to three “inventive concepts” that it claims are present in the patents-in-suit. According to plaintiff, the patents include the inventive concept of “correlating the location information of a communications device with the location of freight or a vehicle.” Plaintiff claims that this provides a technical solution to a technical problem, namely “how to monitor the location of freight or vehicle by technical means other than a dedicated GPS receiver installed in the vehicle.” According to plaintiff, this is a technical solution because it allows the tracking of freight without the use of a dedicated GPS receiver and instead discerns the location through a location information provider and correlates the device’s location to that of the freight or vehicle.

In addition, the plaintiff argues that patents are inventive because they obtain location information through an intermediary and not directly from the communication device itself. Plaintiff argues that this second inventive concept further reduces reliance on GPS-based information in order to determine freight location.

According to plaintiff, the patents-in-suit contain a third inventive concept. Plaintiff points out that claim 1 of the ’943 patent provides a “signal including data that prompts an

automated message to be communicated to a use of the communications device” and a “signal including data indicative of consent from the user” regarding the location of the device.

According to plaintiff, this solves the technical problem of obtaining consent for location information from the owner of the device. Plaintiff claims that use of a manual or automatic system to call each user individually in order to obtain consent would be prohibitively inconvenient. Plaintiff claims that this is an inventive concept that is “tethered to the technology that created the problem” and is therefore akin to *DDR Holdings*.

As an initial matter, the Court agrees with defendant that plaintiff’s first proposed inventive concept amounts to the correlation of information. “[C]orrelating” information, however, does not add an inventive concept. Correlating simply connotes the ascertaining of a relationship between two pieces of information. Here, plaintiff does not profess to have invented the ability to locate freight through the use of signals. Rather, the patents-in-suit simply instruct that a computer use preexisting technology to implement the correlation. This type of use of data, however, involves only the conventional use of a computer. Further, the Court agrees with defendant that plaintiff’s proposed technological improvement is lacking in the claim language itself. According to plaintiff, the patents-in-suit solve the technical problem of obtaining location information by means other than use of a dedicated GPS receiver and further allows for an “open” as opposed to a “closed” system. But, as defendant points out, plaintiff fails to point to language in the claims demonstrating that its patents would not apply to a closed system. And, again, plaintiff is not claiming that it invented these other methods of tracking freight.

The same holds true for plaintiff’s second and third proposed inventive concepts, *i.e.*, obtaining location information through an intermediary and obtaining consent. Plaintiff argues

that these concepts further reduce reliance on GPS-based information in order to determine freight location and solve the “unique” problem of obtaining consent. The claim language, however, accomplishes these tasks through the ordinary use of a computer that “transmits” and “receives” data from a communication device and the “location information provider.” Again, transmitting and receiving data are basic and generic computer functions and these claims do not solve any problem “tethered to the technology that created the problem.” *See, DDR Holdings, LLC v. Hotels.com L.P.*, 773 F.3d 1245 (Fed. Cir. 2014). In fact, as defendant notes, the patents-in-suit incorporate pre-existing industry standards for notice and consent in relation to the use of tracking systems. As such, the obtaining of consent was already known in the industry before the issuance of the patents-in-suit. The patents simply use a computer to “transmit” and “receive” data in order to accomplish this task. These limitations—either individually or as an ordered combination—do not transform the abstract idea into a patent-eligible application.

The overall gist of plaintiff’s argument is that the concept of using a third-party intermediary to locate freight and obtain consent is an inventive concept because this method has not been used in the freight tracking industry. But, “[e]ven if some steps in the claims ‘were not previously employed in this art is not enough—standing alone—to confer patent eligibility upon the claims at issue.’” *Essocite, Inc. V. Clickbooth.com, LLC*, 2015 WL 1428919 (C.D. Cal. Feb. 11, 2015)(quoting *Ultramercial*, 772 F.3d at 716)). Here, plaintiff offers nothing “in addition” to the argument that these steps have not been used in the industry. This is insufficient to confer patent eligibility.

Plaintiff’s reliance on *DDR Holdings* is further misplaced. As set forth above, the patent in *DDR Holdings* was patent eligible because it contained solution “necessarily rooted in

computer technology in order to overcome a problem specifically arising in the realm of computer networks.” Plaintiff attempts to compare its patent to *DDR Holdings* on the basis that requiring consent to determine location is a “new” problem that is specific to the technology of advanced communication devices. This Court disagrees. As an initial matter, asking an individual permission to ascertain location is not a solution to a technological problem. Rather, long before privacy concerns arose with the use of GPS and other types of cellular locators, humans were able to inquire as to another individual’s location through the use of a telephone. The caller could ask for a location and the respondent could either provide or decline to provide his location. Plaintiff’s patent simply uses a computer to perform this function. As such, the Court finds that using a computer to ask for permission before using a locating device does not solve a technological problem. Nor does the problem identified by plaintiff “specifically aris[e] in the realm of computer networks.” Thus, the Court disagrees that the patent at issue in *DDR Holdings* is similar to the patents-in-suit.

Plaintiff also relies on *Messaging Gateway*, 2015 WL 1744343, in support of its position that the patents-in-suit are valid. The patent in *Messaging Gateway* was directed at a method of using a computer system to facilitate two-way communication between a mobile device and an Internet server.” The court found the patent analogous to *DDR Holdings*. Specifically, the court found that the patent describes an interaction between a mobile phone system and a computer, which overrides conventional practice. The court noted that “conventional” phones could not send SMS text messages to computers. Therefore, the court reasoned, the patent contained an inventive concept because it was “tethered to the technology that created the problem.” The Court finds that *Messaging Gateway* is inapposite because, as set forth above, plaintiff does not

establish that the patent's purported inventive concepts solve a problem rooted in the technology that created the problem.

Although not raised by the parties, the Court finds further support for its conclusion in the fact that the claims do not survive the "machine or transformation test." The "machine or transformation" test looks to whether a process is (1) "tied to a particular machine or apparatus or (2) transforms a particular article into a different state or thing." *Ultramercial*, 772 F.3d at 716. Although not dispositive, the "machine or transformation" test is nonetheless a "useful and important clue, an investigative tool, for determining whether some claimed inventions are processes under § 101." *Bilski v. Kappos*, 561 U.S. 593, 604 (2010). *See also, Mayo*, 132 S.Ct. at 1303. Here, the patents are not tied to any particular machine or apparatus. Rather, they require only a general purpose computer. The patents also fail the second prong of the "machine or transformation test" because implementation of the method or system results in no transformation.

Plaintiff also argues that its patents do not preempt the field of "tracking freight" and thus the concerns of the *Mayo* court do not apply. Again, this Court disagrees. Although the patents-in-suit do not entirely foreclose all tracking of freight, the steps in the claimed invention do involve "well-understood, routine, conventional activity." *Mayo*, 132 S.Ct. at 1294. Thus, "upholding the patents would risk disproportionately tying up the use of the underlying" conventional steps. *Id.* Accordingly, plaintiffs' argument is not well-taken.<sup>3</sup>

---

<sup>3</sup> Plaintiff repeatedly argues that the Reasons for Allowance issued with respect to the patents-in-suit note that the patent is distinguishable from prior art. Therefore, plaintiff claims that the patents are directed at patent-eligible subject matter. The Court disagrees. Nothing in the Reasons for Allowance dictate a finding that these concepts are inventive on the issue of patent-eligible



C. System claims

Having concluded that the method claims are invalid under Section 101, the Court finds that, for the same reasons, the system claims are invalid. In substance, the method and system claims do not differ. *See, Alice Corp.*, 134 S.Ct. at 2360.

**CONCLUSION**

For the foregoing reasons, Defendant FourKites, Inc.'s Motion to Dismiss First Amended Complaint for Failure to State a Claim Upon Which Relief Can Be Granted as a Matter of Law (Doc. 18) is GRANTED.

IT IS SO ORDERED.

/s/ Patricia A. Gaughan  
PATRICIA A. GAUGHAN  
United States District Judge

Dated: 11/6/15

---

subject matter. Nor is the guidance put forth by the PTO conclusive on the issue of patent-eligible subject matter. Regardless, other than a blanket statement that the Examiner presumably applied the guidance, plaintiff offers no analysis on the issue.

2

## Opposition

# Plaintiff MacroPoint, LLC's Opposition to Defendant FourKites, Inc.'s Motion to Dismiss First Amended Complaint

**IN THE UNITED STATES DISTRICT COURT  
FOR THE NORTHERN DISTRICT OF OHIO  
EASTERN DIVISION**

**MacroPoint, LLC,**

Plaintiff,

vs.

**FourKites, Inc.,**

Defendant.

CASE NO.: 1:15CV1002

JUDGE PATRICIA A. BAUGHAN

**PLAINTIFF MACROPOINT, LLC'S OPPOSITION TO  
DEFENDANT FOURKITES, INC.'S MOTION TO DISMISS  
FIRST AMENDED COMPLAINT**

TABLE OF CONTENTS

I. INTRODUCTION ..... 1

II. BACKGROUND ..... 3

    A. MacroPoint..... 3

    B. The Patent-in-Suit ..... 4

    C. Conventional Tracking Methods are Limited ..... 4

    D. The Patents-in-Suit Are Novel..... 6

III. LEGAL ARGUMENT ..... 7

    A. Standard Of Review..... 7

        1. Patents are Presumed Valid ..... 8

        2. Clear And Convincing Evidence Standard Applies..... 9

        3. The Burden is Especially Heavy Because The Patent Examiner Already Considered FourKites' Asserted Basis For Invalidity..... 9

    B. Defendant Failed To Satisfy Its Burden ..... 10

        1. The patents-in-suit already passed Alice's two-part test..... 10

        2. FourKites' Assertion Is Not Supported By The Case Law..... 11

            a. FourKites' reliance on Ultramercial is misplaced ..... 11

            b. FourKites' reliance on Wireless Medical Innovations is misplaced..... 12

            c. The cases cited by FourKites are inapposite ..... 14

    C. Standard For Patent-Eligible Subject Matter – The Two-Part Test ..... 15

1.	<u>FourKites Fails to Demonstrate that the Claims Preempt the Field of Tracking Freight with a Computer</u> .....	16
2.	<u>The Claims of the Patents-in-Suit are Directed to more than an Abstract Idea</u> .....	18
3.	<u>The Claims of the Patents-in-Suit Pass the Second Part of the Alice Test</u> .....	23
a.	<u>A First Inventive Concept – Correlation of Location Information of a Communications Device to Location of the Freight or a Vehicle</u> .....	24
b.	<u>A Second Inventive Concept – Obtaining Location Information of Communications Device from a “Location Information Provider” – a Party or Device Other than the Communications Device</u> .....	26
c.	<u>Third Inventive Concept – Providing Notice and/or Consent to the User that Location Information of the Communications Device is being Obtained</u> .....	27
IV.	CONCLUSION.....	30

**TABLE OF AUTHORITIES**

	<b>Page(s)</b>
<b>Cases</b>	
<i>Alice Corp. Pty. Ltd. v. CLS Bank Int'l</i> , 134 S. Ct. 2347 (2014).....	<i>passim</i>
<i>Ameritox, Ltd. v. Millennium Health, LLC</i> , No. 13-cv-832-wmc, 2015 U.S. Dist. LEXIS 53818 (W.D. Wis. Apr. 24, 2015).....	9
<i>Bilski v. Kappos</i> , 561 U.S. 593 (2010).....	15, 21
<i>CLS Bank Int'l v. Alice Corp. Pty.</i> , 717 F.3d 1269 (Fed. Cir. 2013).....	21
<i>Data Distrib. Techs., LLC v. Brer Affiliates, Inc.</i> , No. 12-4878, 2014 U.S. Dist. LEXIS 115543 (D.N.J. Aug. 19, 2014).....	9
<i>DDR Holdings, LLC v. Hotels.com. L.P.</i> , 773 F.3d 1245 (Fed. Cir. 2014).....	22, 23, 29
<i>Ennenga v. Starns</i> , 677 F.3d 766 (7th Cir. 2012) .....	10
<i>Impax Labs, Inc. v. Aventis Pharms. Inc.</i> , 545 F.3d 1312 (Fed. Cir. 2008).....	9
<i>Lawrence v. Chancery Court of Tenn.</i> , 188 F.3d 687 (6th Cir. 1999) .....	7
<i>Mayo Collaborative Servs. v. Prometheus Labs, Inc.</i> , 132 S. Ct. 1289 (2012).....	15, 16, 21, 22
<i>Messaging Gateway Solutions, LLC v. Amdocs, Inc.</i> , 2015 U.S. Dist. LEXIS 49408 (D. Del. Apr. 15, 2015).....	22, 23
<i>Progressive Cas. Ins. Co. v. Safeco Ins. Co.</i> , No. 1:10 CV 1370, 2010 U.S. Dist. LEXIS 120225 (N.D. Ohio Nov. 12, 2010) (J. Gaughan).....	8, 9, 13
<i>Ultramercial, Inc. v. Hulu, LLC</i> , 772 F.3d 709 (Fed. Cir. 2014).....	<i>passim</i>

*Vita-Mix Corp. v. Basic Holdings, Inc.*,  
No. 1:06 CV 2622, 2007 U.S. Dist. LEXIS 71947 (N.D. Ohio Sept. 27, 2007)  
(J. Gaughan).....7, 11

*Wireless Media Innovations, LLC v. Maher Terminals, LLC*,  
Nos. 14-7004; 14-7006, 2015 U.S. Dist. LEXIS 51811 (D.N.J. Apr. 20, 2015).....3, 12, 13

**Statutes**

35 U.S.C. § 101 ..... *passim*

35 U.S.C. §§ 102, 103, and 112 .....2

35 U.S.C. § 282.....8

**Other Authorities**

76 FR 74618.....10

Fed. R. Civ. P. Rule 12(b)(6).....7

## I. INTRODUCTION

FourKites contends that the patents-in-suit are invalid because they claim an “abstract idea” and that FourKites should be free to appropriate MacroPoint’s invention. FourKites is wrong. Contrary to FourKites’ contention, the claims of the patents-in-suit are precisely the type of claims that are patent-eligible subject matter under 35 U.S.C. § 101 as set forth in the Supreme Court’s *Alice* decision. Reduced to its logical conclusion, FourKites’ argument leaves no doubt that it would like this Court to simply conclude that *Alice* holds that all patent claims with any connection to software are “abstract ideas” and are not patent-eligible subject matter. FourKites contends that it need only to articulate an abstract idea that purports to encompass the subject matter of the patents-in-suit in their broadest sense, strip the claims of all limitations, replace those limitations with a generic summary, and conclude that the patents-in-suit are therefore “abstract.” This is no different than characterizing Edison’s light bulb as “a means for illumination” or the Wright Brothers’ plane as “a means for travel” and thereby render these inventions as no more than “abstract” ideas. To this end, FourKites uses *Alice* and its progeny as a shibboleth, not as a basis for sound argument.

The Supreme Court established a two-part test for determining if claims are patent-eligible subject matter under 35 U.S.C. § 101. See *Alice Corp. Pty. Ltd. v. CLS Bank Int’l*, 134 S. Ct. 2347, 2355 (2014). Unfortunately for FourKites, this two-part test requires actual analysis of the claim limitations of the patents-in-suit and not counsel’s truncated summary of the claims. FourKites’ arguments are thoroughly deficient. FourKites’ arguments lack the required analysis of all claims and all limitations of those claims. FourKites’ arguments consider only a handful of words in the claims before concluding that ninety-four claims across five patents-in-suit are not patent-eligible subject matter. FourKites fails to satisfy its burden in proving that the patents-in-suit are invalid under 35 U.S.C. § 101 as a matter of law.



As discussed below, when the claim limitations are properly analyzed under the two-part *Alice* test, it is clear that the claims of the patents-in-suit are patent-eligible subject matter. In fact, the United States Patent and Trademark Office (“PTO”) *already* determined that claims of the patents-in-suit not only are directed to patent-eligible subject matter under 35 U.S.C. § 101 as set forth in *Alice*, but patentable under all legal requirements, including 35 U.S.C. §§ 102, 103, and 112.

FourKites’ most glaring omission is its lack of any acknowledgement whatsoever that four of the five patents-in-suit were examined and granted by the PTO *after* both the *Alice* decision and the PTO’s issuance of specific guidelines regarding the examination of claims in light of the *Alice* two-part test.<sup>1</sup> Tellingly, FourKites ignores this critical fact. FourKites asks this Court to invalidate patents examined and granted by the PTO, with full knowledge and understanding of *Alice* and its two-part test, based only on FourKites’ superficial analysis of the claims. The PTO’s post-*Alice* examination, grant, and issuance provide the claims of the patents-in-suit with a presumption of validity. A presumption that FourKites’ analysis and arguments fail to overcome.

Additionally, FourKites’ arguments lack any discussion as to the applicable evidentiary standard. Where a party challenges the validity of a patent, the challenging party’s burden is to show the patent is invalid by clear and convincing evidence. Again, it is telling that FourKites omitted any discussion of evidentiary standard because FourKites’ Motion to Dismiss falls well short of satisfying this burden.

Finally, FourKites’ relies heavily on two distinguishable and inapplicable cases –

---

<sup>1</sup> The *Alice* decision issued on June 19, 2014. The PTO issued its first set of examination guidelines in light of *Alice* on June 25, 2014, and its second set of examination guidelines on December 16, 2014. (See Exs. 1 and 2, respectively) The ‘295, ‘097, 098, and ‘313 patents were examined from February to April of 2015 and issued in June or July of 2015.

*Ultramercial, Inc. v. Hulu, LLC*, 772 F.3d 709, 720 (Fed. Cir. 2014) and *Wireless Media Innovations, LLC v. Maher Terminals, LLC*, Nos. 14-7004; 14-7006, 2015 U.S. Dist. LEXIS 51811 (D.N.J. Apr. 20, 2015) – and a listing of twenty-five cases without analysis or argument as to why even one of these twenty-five cases is applicable or even relevant to the patents-in-suit. Unsurprisingly, each of these twenty-five cases involves patents granted before the *Alice* decision, and thus, examined by the PTO without any knowledge of *Alice* or the benefit of the PTO’s *Alice* guidelines.

Simply put, FourKites has failed to meet its burden in seeking to have the First Amended Complaint dismissed. Thus, FourKites’ Motion to Dismiss should be denied.

## II. BACKGROUND

### A. MacroPoint

Plaintiff MacroPoint, based in Cleveland, Ohio, develops and licenses monitoring and tracking solutions for shippers, brokers and third party logistics providers. Since its founding, MacroPoint has invested significant time, energy and resources to researching, developing, and implementing innovative technologies that provide novel solutions for the freight tracking industry. As part of this investment of resources, MacroPoint has allocated much labor and capital to diligently pursuing patent rights to protect its innovative technology. MacroPoint is the owner of seven U.S. patents, including the five patents-in-suit.

MacroPoint’s innovative technologies facilitate automated monitoring and tracking services and provides third parties with visibility to the location of vehicles and freight. MacroPoint’s technology can be used with cell phones, including both “smartphones” and older “flip phones,” and electronic logging devices (“ELD”) that can be secured to a vehicle. MacroPoint’s solutions provide real-time location monitoring and tracking, delivery monitoring, and event notifications to third parties. To date, MacroPoint’s solutions enable the tracking of

approximately 300,000 drivers and vehicles, which support thousands of brokers, shippers and trucking companies.

B. The Patent-in-Suit

The patents-in-suit are U.S. Patent Nos. 8,604,943 (the “‘943 patent”); 9,070,295 (the “‘295 patent”); 9,082,097 (the “‘097 patent”); 9,082,098 (the “‘098 patent”); and 9,087,313 (the “‘313 patent”) (collectively, “patents-in-suit”). (See, First Amended Complaint, D.I. 16, Exs. A-E.) The ‘943 patent issued on December 10, 2013, and the remaining four patents-in-suit issued between June 30, 2015, and July 21, 2015, more than a year *after* the Supreme Court’s *Alice* decision.<sup>2</sup> The patents-in-suit are directed to systems and methods for obtaining or monitoring the location of a vehicle and freight carried by a vehicle utilizing a communications device correlated to the vehicle or freight, where the location of the communications device is received from a party or device other than the communications device itself (*i.e.*, a third party) and the user of the communications device provides consent for obtaining and transmitting location information about the communications device. (See ‘943 patent at 2:14-36.)<sup>3</sup> Systems and methods of the patents-in-suit solve specific problems of tracking vehicles and freight by providing an unconventional technological environment. (See Zatkovich Decl. at ¶¶ 90-91.)<sup>4</sup>

C. Conventional Tracking Methods are Limited

At the time of the invention of the patents-in-suit, conventional methods and systems for tracking vehicles and freight suffered from a number of shortcomings and challenges when compared to the methods and systems of the patents-in-suit, and the patents-in-suit address and

---

<sup>2</sup> The ‘295 patent issued on June 30, 2015; the ‘097 and ‘098 patents issued on July 14, 2015; and the ‘313 patent issued on July 21, 2015.

<sup>3</sup> All the patents-in-suit share a common written description and drawings. References to the written description of drawings of the patents-in-suit will generally be made to the ‘943 patent.

<sup>4</sup> Plaintiff MacroPoint submits as Ex. 3, the Declaration of Ivan Zatkovich in Support of MacroPoint’s Opposition to FourKites Motion to Dismiss. Mr. Zatkovich is a technical expert with over thirty years of experience in computer science and computer network architecture, including experience in tracking freight. (See *id.* at ¶¶ 4-15.)

resolve those challenges. For example, the architecture of conventional systems results in a “closed system.” (Zatkovich Decl. at ¶¶ 48-63.) In a closed system, transmission of vehicle and freight location information is limited to a closed user group. For example, location information may be transmitted only between vehicles in a freight company’s fleet and the freight company’s dispatch center or monitoring service. (*Id.*) Closed systems are typically proprietary to a freight company. (*Id.*) The freight company’s clients, such as shippers that contract with the freight company to ship freight, need to rely on the freight company to relay the client’s freight’s location information. (*Id.*) The freight company can provide its clients with subscription based monitoring services; however, such services can be prohibitively expensive for clients that monitor small numbers of vehicles or loads. (’943 patent at 1:37-44; Zatkovich Decl. at ¶ 57.) Users of closed systems must be familiar with and interoperate with multiple closed systems if they wish to use more than one carrier system, as is typical in the freight industry. (Zatkovich Decl. at ¶¶ 48-63.)

Another limitation of conventional systems is standardization of methods and equipment used to track location of a vehicle or freight. For example, conventional systems typically install the same tracking equipment in all vehicles to be tracked and use a common method for tracking all vehicles. (Zatkovich Decl. at ¶ 59.) Such standardization provides for a rigid system that can track only vehicles or freight equipped with the right type of equipment. Additionally, conventional systems “discretely” monitor the location of a vehicle or freight by monitoring only the last known position, *i.e.*, a distribution center, location of a pickup or delivery, or other discrete check points. (*Id.* at ¶¶ 60-62.) Such monitoring does not provide for “real-time” monitoring of vehicles or freight.

D. The Patents-in-Suit Are Novel

The patents-in-suit are directed to novel and specific ways of tracking vehicles and freight. The patents-in-suit claim the tracking of a vehicle or freight in part by determining the location of a communications device that is correlated to the vehicle or freight. The location of the communications device is received from a “location information provider.” The location information provider is a party or device other than the communications device itself, *i.e.*, a third party or device controlled by a third party. (‘943 patent at 4:33-50.) The location information provider can be:

- a wireless service provider providing wireless service to the communications device,
- a third party that obtains the location information of the communications device from the wireless service provider providing wireless service to the communications device, or
- a party that has access to the location information of the communications device but is other than the wireless service provider or the third party that obtains the location information of the communications device from the wireless service provider.

(*Id.* at 21:19-29.) The use of a location information provider results in an “open system,” where the location of a vehicle or freight can be shared outside the group. Unlike conventional systems, location information is not directly received from the vehicle, and the location information is not directly sent from the vehicle to the freight company. In the claimed systems and methods of the patents-in-suit, requests for location information are sent to the location information provider, and those requests are for location of a communications device. (‘943 patent at 2:14-35; Zatkovich Decl. at ¶¶ 70-71.) The claimed systems and methods use location information of communications devices to then determine the location of vehicles and freight.

The advantages of an open system include: support for multiple parties, including the freight company and its clients, to request vehicle and freight location information; support for communications devices that span multiple technologies; enhancing the ability of shippers and

brokers to use multiple carrier system; and real-time tracking location of vehicles or freight because third parties such as wireless services have the technology to monitor communications devices continuously in real-time. (Zatkovich Decl. at ¶¶ 70-75.)

The use of a location information provider to facilitate an open system creates technical challenges that need to be solved to implement such systems. A new network architecture is required to integrate one or more third party location information providers, facilitate the use of multiple types of communications devices, and handle location requests for vehicles and freight from multiple parties. (*Id.*) Additionally, open systems have privacy concerns that are addressed by the claimed systems and methods of the patents-in-suit. (*Id.* at ¶¶ 84-89.) The patents-in-suit solve these challenges, and provide innovative improvements over conventional systems. (*Id.*)

Each of these specific technological innovations make the patents-in-suit necessarily more than an “abstract” idea. The patents-in-suit rest on specific, tangible and valuable improvements that provide precisely the sort of inventive concept that constitutes patentable subject matter under 35 U.S.C. § 101.

### III. LEGAL ARGUMENT

#### A. Standard Of Review

When considering a motion to dismiss made under Rule 12(b)(6) of the Federal Rules of Civil Procedure, the district court must accept all of the allegations in the complaint as true and construe the complaint liberally in favor of the plaintiff. *Vita-Mix Corp. v. Basic Holdings, Inc.*, No. 1:06 CV 2622, 2007 U.S. Dist. LEXIS 71947, at \*4-5 (N.D. Ohio Sept. 27, 2007) (J. Gaughan) (citing *Lawrence v. Chancery Court of Tenn.*, 188 F.3d 687, 691 (6th Cir. 1999)). Further, when an allegation is capable of more than one inference, it must be construed in the plaintiff's favor. *Id.*

1. Patents are Presumed Valid

“By statute, a patent is presumed to be valid, and each claim of a patent is presumed to be valid independently of the validity of the other claims.” *Progressive Cas. Ins. Co. v. Safeco Ins. Co.*, No. 1:10 CV 1370, 2010 U.S. Dist. LEXIS 120225, \*7-8 (N.D. Ohio Nov. 12, 2010) (J. Gaughan) (citing 35 U.S.C. § 282). This presumption should apply to FourKites’ Motion.

It has been suggested that such a presumption of validity should not apply when assessing whether claims meet the demands of § 101 because, as stated by Circuit Judge Mayer in a concurring opinion, the PTO “has for many years applied an insufficiently rigorous subject matter eligibility standard ....” *Ultramercial, Inc. v. Hulu, LLC*, 772 F.3d 709, 720 (Fed. Cir. 2014). The circumstances that concerned Circuit Judge Mayer, however, do not apply here. In the wake of the Supreme Court’s *Alice* decision, the PTO twice issued specific guidelines to its examiners, which specifically instructed those examiners on how to determine patentability under § 101 in light of *Alice*. Here, four of the five patents-in-suit were examined and issued *after* the *Alice* decision, *after* the PTO issued specific guidelines regarding the *Alice* decision, and *after* the PTO formally trained its examiners in applying those guidelines. (See Kunin Decl. at ¶13.)<sup>5</sup> Thus, the PTO’s informed examination of four of the five patents-in-suit found the claims of the patents to be patent-eligible subject matter under the standard set forth in *Alice*. (See *id.*) The four patents-in-suit examined and issued by the PTO post-*Alice* (‘295 patent, ‘097 patent, ‘098 patent, and ‘313 patent) are all continuations of the ‘943 patent and subject to terminal disclaimers in light of the ‘943 patent.<sup>6</sup> If the claims of the four patents-in-suit

---

<sup>5</sup> Plaintiff MacroPoint submits as Ex. 4, the Declaration of Steven G. Kunin in Support of MacroPoint’s Opposition to FourKites Motion to Dismiss. Mr. Kunin is an expert in PTO practices and procedures. Mr. Kunin has over thirty years of experience with the PTO, including ten years as Deputy Commissioner for Patent Examination Policy. See *id.* at ¶¶ 4-7.

<sup>6</sup> During the examination of the ‘295, ‘097, ‘098, and ‘313 patents, the PTO issued “nonstatutory double patenting” rejections citing the claims of the related ‘943 patent. (See Ex. 5, excerpts from prosecution history of patents-in-suit.) Essentially, such a rejection is a statement by the PTO examiner that the claims of the related ‘943 patent

examined post-*Alice* passed muster as subject matter eligible, then the claims in the '943 patent would do so as well. (Kunin Decl. at ¶14.) Thus, all of the patents-in-suit should be afforded the presumption of validity when evaluating FourKites' Motion to Dismiss.

2. Clear And Convincing Evidence Standard Applies

A party challenging patent validity has the burden to show by clear and convincing evidence that the patent is invalid. *Progressive Cas. Ins. Co.*, 2010 U.S. Dist. LEXIS 120225 at \*8 (citing *Impax Labs, Inc. v. Aventis Pharms. Inc.*, 545 F.3d 1312, 1314 (Fed. Cir. 2008)). See also, *Ameritox, Ltd. v. Millennium Health, LLC*, No. 13-cv-832-wmc, 2015 U.S. Dist. LEXIS 53818, at \*3 (W.D. Wis. Apr. 24, 2015) (finding defendant failed to demonstrate through clear and convincing evidence that the patent is invalid under § 101); *Data Distrib. Techs., LLC v. Brer Affiliates, Inc.*, No. 12-4878, 2014 U.S. Dist. LEXIS 115543, at \*40 (D. N.J. Aug. 19, 2014) (observing that for the court to hold that the patent fails the *Alice* test, there must be clear and convincing evidence that every claim is invalidly abstract and contains only generic computer applications under any plausible construction of all claims). In its challenge to the validity of the patents-in-suit under 35 U.S.C. § 101, FourKites must satisfy the burden of showing by clear and convincing evidence that each claim of the patents-in-suit is invalid.

3. The Burden is Especially Heavy Because The Patent Examiner Already Considered FourKites' Asserted Basis For Invalidity

When faced with a similar § 101 challenge under Rule 12(b)(6), this Court noted that the patent challenger's burden is especially heavy when the patent examiner considered the asserted basis for invalidity during patent prosecution. *Progressive Cas. Ins. Co.*, 2010 U.S. Dist. LEXIS 120225 at \*15-16 (citing *Impax Labs*, 545 F.3d at 1314). Here, FourKites challenges the validity

---

either anticipate or render obvious the claims of the pending application. (*See, id.*) The applicant overcame these rejections by the filing of a terminal disclaimer, which effectively makes the terms of the issued patent and pending application coterminous. (*See, id.*)



of the patents-in-suit under 35 U.S.C. § 101 post-*Alice*. Specifically, FourKites asserts that the patents-in-suit are directed to patent-ineligible subject matter (*i.e.* abstract ideas). FourKites faces a heavy burden to show invalidity as a matter of law because, as discussed below, the PTO's patent examiner previously considered FourKites' asserted basis for invalidity and granted the subject matter of the patents-in-suit. (Kunin Decl. at ¶13.)

B. Defendant Failed To Satisfy Its Burden

1. The patents-in-suit already passed *Alice's* two-part test

On June 19, 2014, the Supreme Court issued its opinion in *Alice*. *Alice Corp.*, 134 S. Ct. at 2347. Less than a week later, on June 25, 2014, the PTO issued a Memorandum regarding the "Preliminary Examination Instructions in view of the Supreme Court Decision in *Alice Corporation Pty. Ltd. v. CLS Bank International, et al.*" (See Ex. 1.) These instructions specifically related to "subject matter eligibility claims involving abstract ideas, particularly involving computer-implemented abstract ideas, under 35 U.S.C. § 101." (*Id.* at p. 1.) The Memorandum provides that "further guidance will be issued" after additional consideration of the *Alice* decision and public feedback. (*Id.*) On December 16, 2014, the PTO issued the "2014 Interim Guidance on Patent Subject Matter Eligibility" See 76 FR 74618. (See Ex. 2.) The Court may take judicial notice of these dates and public documents. *Ennenga v. Starns*, 677 F.3d 766, 774 (7th Cir. 2012) (noting that a court may take judicial notice of dates readily ascertainable from public records when deciding a Rule 12(b)(6) motion).

Four of the five patents-in-suit were duly examined and granted by the PTO after the issuance of the PTO's 2014 Interim Guidance on Patent Subject Matter Eligibility and subsequently issued between June 30, 2015 and July 21, 2015. (See, First Amended Complaint, D.I. 16 at Exs. B-E.) It is indisputable that four of the patents-in-suit issued more than a year after the *Alice* decision and more than six months after the PTO issued its 2014 Interim Guidance

on Patent Subject Matter Eligibility. It is at least a reasonable presumption—if not a fact—that these four patents were examined in accordance with the PTO’s post-*Alice* guidelines, which applies the two-part test to determine patentable subject matter under 35 U.S.C. § 101. At this stage of the pleadings such a presumption should be construed in MacroPoint’s favor. *Vita-Mix Corp.*, 2007 U.S. Dist. LEXIS 71947, at \*4-5. Nothing in the evidentiary record supports FourKites’ patent invalidity assertions—in fact the record supports the exact opposite.

Tellingly, FourKites completely ignores the evidentiary record and the fact that the PTO already evaluated the subject matter of the patents-in-suit under the two-part *Alice* test and found the subject matter to be patent-eligible. FourKites asks this Court to invalidate ninety-four claims across five patents based on its “analysis” of two claims in a single patent, and without any evidence supporting such a request. FourKites’ Motion consists of nothing more than attorney argument and a listing of distinguishable cases that are inapposite here. Thus, FourKites’ Motion to Dismiss should be denied.

2. FourKites’ Assertion Is Not Supported By The Case Law

a. FourKites’ reliance on *Ultramercial* is misplaced

FourKites relies heavily on *Ultramercial, Inc. v. Hulu, LLC*, 772 F.3d 709 (Fed. Cir. 2014) to support its Motion to Dismiss. *Ultramercial, Inc.* is distinguishable from the patents-in-suit, and FourKites’ reliance on this case is misplaced. *First*, the patent at issue in *Ultramercial, Inc.* was examined and issued prior to the *Alice* decision and the issuance of the PTO’s corresponding examination guidelines, while the patents-in-suit here were examined, granted, and issued **post-*Alice***. This is a significant distinction and fatal to FourKites’ Motion to Dismiss. *Second*, unlike the claim in *Ultramercial* the challenged claims here contain an inventive concept. (Zatkovich Decl. at ¶¶ 132-37.)

*Alice* and *Ultramercial* do not create a bright line rule that all software claims are abstract

ideas and, therefore, ineligible subject matter. In fact, the Federal Circuit acknowledged that it does not conclude that all software-based claims will constitute abstract ideas, and that future cases may turn out differently. *Ultramercial, Inc.* 772 F.3d at 715.

Tellingly, FourKites makes no effort to perform the two-part *Alice* test referenced in *Ultramercial*. FourKites' reliance on *Ultramercial* consists solely on asserting that the claims at issue here and in *Ultramercial* share three words (sending, receiving, and correlating). (Mot. To Dismiss, D.I. 18, at p. 15.) As a result, FourKites has asked this Court to ignore the PTO's examination process and the claims themselves, and invalidate five patents based on nothing more than three words. FourKites' reliance on *Ultramercial* does not satisfy its heavy burden.

b. FourKites' reliance on *Wireless Media Innovations* is misplaced

FourKites also relies on *Wireless Media Innovations, LLC v. Maher Terminals, LLC*, Nos. 14-7004; 14-7006, 2015 U.S. Dist. LEXIS 51811 (D.N.J. Apr. 20, 2015). (Mot. To Dismiss, D.I. 18, at pp. 15-16.) FourKites' reliance on *Wireless Media Innovations* also is misplaced. The patents at issue in *Wireless Media Innovations* were examined and issued pre-*Alice*, a conclusive distinction. FourKites asserts—without any factual or legal support—that the claims in *Wireless Media Innovations* are like the claims of the patent-in-suit. FourKites is wrong. The claims of the patents challenged in *Wireless Media Innovations* have nothing in common with the claims at issue here. (See Exs. 6 and 7, U.S. Pat. Nos. 5,712,789 and 6,148,291, respectively.)

The claims in *Wireless Media Innovations* are directed to tracking shipping containers in a local, closed, single-channel, discrete environment. (Zatkovich Decl. at ¶¶ 138-41.) For example, independent claim 21 of Pat. No. 6,148,291 recites only:

21. A method for using a computer to monitor usage of one or more docks associated with a facility, wherein the usage involves the presence or absence of a container at a dock, the method of comprising the steps of:

- (a) recording the presence of an identified container at a particular identified dock,
- (b) recording the absence of an identified container at a particular identified dock,
- (c) producing a report which identifies monitored docks and identifies containers present at identified docks, and also identifies docks at which a container is absent.

Any comparison between the claims at issue in *Wireless Media Innovation* and the claims of the patents-in-suit<sup>7</sup> concludes that no legitimate equivalency can be found.

The claims of the patents-in-suit are directed to systems and methods for obtaining or monitoring the location of a vehicle or freight utilizing a communications device correlated to the vehicle or freight, where the location of the communications device is received from a party or device other than the communications device itself (*i.e.*, a third party) and the user of the communications device provides consent for obtaining and transmitting location information about the communications device. Unlike the patents of *Wireless Media Innovations*, the claims of the patents-in-suit provide for an open system for multi-channel, real-time tracking of vehicles and freight nationwide.

Further, MacroPoint agrees that the claims in *Wireless Media Innovations* could be performed solely by a human using pencil and paper. The claims of the patents-in-suit, however, cannot be performed solely by a human. The claims at issue here, unlike the claims in *Wireless Media Innovations*, utilize technology to solve technological issues encountered in the industry. It is telling that FourKites does not attempt to show how the specific claim language at issue here equates to the claim language in *Wireless Media Innovations*. FourKites' bare assertions without factual or legal support do not satisfy FourKites' heavy burden. Thus, FourKites' Motion to Dismiss should be denied.

---

<sup>7</sup> Limitations of the claims of the patents-in-suit are discussed in Section III(C) of this Memorandum.

c. The cases cited by FourKites are inapposite

FourKites asserts that patent law has changed since this Court denied the motion to dismiss in *Progressive Cas. Ins. Co.*. (Mot. To Dismiss, D.I. 18, at p. 10.) FourKites, however, fails to address the fact that the subject matter of the patents-in-suit was examined, granted, and issued under the new patent law. FourKites also suggests that this Court's reasoning in *Progressive Cas. Ins. Co.* no longer is valid. FourKites is again wrong. The Court's reasoning in *Progressive Cas. Ins. Co.* remains valid and is equally applicable here because the subject matter of the patents-in-suit was examined, granted, and issued under the most current patent law. Moreover, FourKites has not cited any cases challenging this Court's reasoning in *Progressive Cas. Ins. Co.* Thus, the presumption of validity, the clear and convincing standard, and the defendant's burden applied in *Progressive Cas. Ins. Co.* are applicable here.

FourKites devotes over two pages of its Motion to a rote, unexplained list of twenty-five cases where patents were invalidated at the pleadings stage without making any effort to explain how the cases are applicable or even analogous to the facts of this case. (*Id.* at pp. 11-13.) This is akin to listing guilty verdicts in twenty-five criminal cases and arguing that the 26th accused defendant is necessarily guilty as well with no further proceedings warranted. A review of the listed cases reveals a glaring and fatal distinction. In the listed cases, all of the challenged patents were issued prior to both the *Alice* decision and the issuance of the PTO's corresponding examination guidelines. Here, the subject matter of the challenged patents was examined, granted, and issued under the post-*Alice* patent rules. In fact, FourKites does not cite a single case where a court invalidated a patent as an abstract idea that was examined and issued post-*Alice*. Thus, all of the cases cited by FourKites are inapposite here.

It goes without saying that the patents-in-suit must be evaluated on their own merits. FourKites' listing of cases void of any analysis carries no weight. Consequently, FourKites has

failed to satisfy its burden, and its Motion to Dismiss should be denied.

C. Standard For Patent-Eligible Subject Matter – The Two-Part Test

35 U.S.C. § 101 states, “[w]hoever invents or discovers any new and useful process, machine, manufacture, or composition of matter, or any new and useful improvement thereof, may obtain a patent therefor, subject to the conditions and requirements of this title.” There are three exceptions to § 101’s broad patent-eligibility principles: “laws of nature, natural phenomena, and abstract ideas.” *Alice*, 134 S. Ct. at 2358. FourKites alleges that the third category, abstract ideas, is applicable to the patents-in-suit.

The Supreme Court observed that the “concern that drives the exclusionary principle [i]s one of pre-emption.” *Id.* at 2354 (citing *Bilski v. Kappos*, 561 U.S. 593, 612 (2010) (explaining how upholding the patent “would pre-empt use of this approach in all fields, and would effectively grant a monopoly over an abstract idea”)). The Supreme Court has repeatedly emphasized that preemption is a concern where the patent would inhibit “further discovery by improperly tying up the future use of these building blocks of human ingenuity.” *Alice*, 134 S. Ct. at 2354 (citing *Mayo Collaborative Servs. v. Prometheus Labs, Inc.*, 132 S. Ct. 1289, 1301 (2012)). While preemption is a major concern for the Supreme Court, the weighing of the preemptive effect must be analyzed carefully, and courts must “tread carefully lest it swallow all of patent law.” *Id.* (citing *Mayo*, 132 S. Ct. at 1293-94 (“too broad an interpretation of this exclusionary principle could eviscerate patent law.”)). “For all inventions at some level embody, use, reflect, rest upon, or apply laws of nature, natural phenomena, or abstract ideas.” *Id.* Therefore, even patent claims that grow out of an abstract concept are not deemed ineligible on that basis alone. *Id.* (internal citation omitted). Indeed, inventions that are “applications of such concepts to a new and useful end ... remain eligible for patent protection.” *Id.* (internal citation omitted). Accordingly, in applying the § 101 exception, courts must distinguish between patents

that claim the building blocks of human ingenuity and those that integrate the building blocks into something more, thereby transforming them into a patent-eligible invention. *Id.*

Keeping this balance in mind, the Supreme Court established a two-part test for distinguishing between “those patents that claim laws of nature, natural phenomena, and abstract ideas from those that claim patent-eligible applications of those concepts.” *Alice*, 134 S. Ct. at 2355. First, courts must “determine whether the claims at issue are directed to one of those patent-ineligible concepts.” *Alice*, 134 S. Ct. at 2355. If the claims are directed to a patent-ineligible concept, then courts must conduct an analysis to search for an inventive concept—*i.e.*, an element or combination of elements that is sufficient to ensure that the patent in practice amounts to significantly more than a patent upon the ineligible concept itself. *Id.* (internal citation and quotations omitted). In doing so, the court must consider the elements of each claim both individually and as an ordered combination to determine whether the additional elements transform the nature of the claim into a patent-eligible application. *Id.* (internal citation omitted).

1. FourKites Fails to Demonstrate that the Claims Preempt the Field of Tracking Freight with a Computer

The explicit motivating rationale behind the Supreme Court’s decisions in *Alice* and *Mayo* was to recognize that validity of patent claims covering *only* abstract ideas and that add too little to the ineligible subject matter effectively would preempt all uses of that subject matter “tying up the future use of these building blocks of human ingenuity.” *Alice*, 134 S. Ct. at 2354; *see also, Mayo Collaborative Servs.*, 132 S. Ct. at 1301. FourKites fails to address this critical consideration in its Motion. FourKites’ omission is understandable because the claims of the patents-in-suit clearly do not preempt “tracking freight using a computer,” the abstract idea that FourKites asserts is claimed by the patents-in-suit. (Mot. To Dismiss, D.I. 18, at p. 1.)

The claims of the patents-in-suit recite a technology for tracking vehicles and freight in a

specific and novel way. The patents-in-suit claim systems and methods for obtaining or monitoring the location of a vehicle or freight utilizing a communications device correlated to the vehicle or freight, where the location of the communications device is received from a third party and the user of the communications device provides consent for obtaining and transmitting location information about the communications device. The claims of the patents-in-suit include limitations that substantially narrow the claims, which prevents preemption and allows for the practice of other solutions for “tracking freight with a computer” to be practiced. It simply would be absurd to contend that the validity of the claims of the patents-in-suit would somehow preclude others from using computer technology to track vehicles or freight.

By definition, systems and methods for tracking freight existing prior to the conception of the claims of the patents-in-suit are not preempted because they are prior art. Lists of such prior art systems and methods are found on the face of the patents-in-suit. Further, the Specification of the patents-in-suit includes discussion of conventional systems for monitoring vehicle location that rely only on global positioning systems (GPS). (*See* ‘943 patent at 1:31-36.)

FourKites’ Motion itself provides an example of a system and method that is not preempted by the claims of the patents-in-suit – a uFollowit Voice Proof of Delivery & Tracking Service (“uFollowit Service”). In a misguided and premature attempt to argue the claims of the patents-in-suit are invalid as anticipated or obvious, FourKites holds out the uFollowit Service as “just one prior art example, among many other references.” (Mot. To Dismiss, D.I. 18, at p. 21, n. 3.) Predictably, FourKites misses its mark in citing the uFollowit Services as material or invalidating prior art because any company or entity can “track freight using a computer” using the system and method of the uFollowit Services without falling within the scope of the patents-in-suit. The uFollowit Service relies on generating “Proof of Delivery (POD) with recipient’s



voice signature” resulting in “Tracking with: “Voice POD & Text Name of Consignee.” (See Ex. 8<sup>8</sup>, uFollowit Services presentation at p. 2.) Such a system and method of tracking freight is very different from those claimed by the patents-in-suit. Thus, FourKites’ own premature citation to “prior art” illustrates how the claims of the patents-in-suit *do not preempt* other solutions for “tracking freight using a computer.”

2. The Claims of the Patents-in-Suit are Directed to more than an Abstract Idea

FourKites asserts that the claims of the patents-in-suit are “directed to the abstract idea of tracking freight.”<sup>9</sup> (Mot. To Dismiss, D.I. 18, at p. 13.) FourKites is wrong. FourKites offers varying but cursory descriptions of the ninety-four claims of the patents-in-suit, including:

“nothing more than using computers to send, receive, and correlate information” (*id.* at pp. 4, 6);

“all of the claims of the patents-in-suit recycle some combination of seven basic components, each of which are addressed herein: (1) sending / receiving; (2) correlating; (3) using or not using GPS; (4) exposing and/or interfacing with an exposed application programming interface; (5) specifying who is the location information requester; (6) specifying who provides the location information; and (7) displaying a representation of the location information” (*id.* at pp. 7, 19);

“The claims of the patents-in-suit are directed to the basic idea of tracking freight: (1) receiving a request for the location of freight; (2) asking the truck in possession of that freight where it is; and (3) reporting the location of the truck.” (*id.* at p. 14);

“The claims ‘use’ a computer, but they are nothing more than a method of organizing a prior-existing, basic human activity.” (*id.*); and

“an effort to patent the performance of a task that humans have always done” (*id.* at p. 16).

While the patents-in-suit solve problems relating to “tracking freight,” FourKites grossly over-

---

<sup>8</sup> The uFollowit Services presentation was downloaded from <http://www.ufollowit.com/pdf/uFollowitv2.1.pdf> on September 10, 2015.

<sup>9</sup> Defendant does not offer any specifics or detailed claim analysis in its § 101 argument and treats all claims—from any of the patents, independent and dependent, method and system—collectively and as “not substantively different.” (See, e.g., Mot. To Dismiss, D.I. 18, at p. 3.)

simplifies the claims in an obvious and futile attempt to make it all seem as merely an abstract idea. FourKites once again is wrong.

Merely condensing the claims to some abstract concept as FourKites has done is improper and does not follow the *Alice* two-part test. By offering nothing other than several conclusory catch phrases, FourKites renders *Alice*'s first part superfluous. In fact, the Supreme Court specifically cautioned against such an approach when it observed that “[a]t some level, all inventions ... embody, use, reflect, rest upon, or apply laws of nature, natural phenomena, or abstract ideas.” *Alice*, 134 S. Ct. at 2354 (internal citation and quotation omitted). The Supreme Court further advises that “we consider the elements of each claim both individually and as an ordered combination.” *Id.* at 2355 (internal citation and quotations omitted). Although FourKites cites this very language in its Motion (Mot. To Dismiss, D.I. 18, at p. 9), it does not follow the Supreme Court’s guidance and improperly analysis the claims.

In its cursory summation of the claims of the patents-in-suit, FourKites ignores the claims’ detailed limitations, none of which simply recite the actions of “sending,” “receiving,” or “correlating.” By way of illustration only, claim 1 of the ‘943 patent does not simply claim “sending,” it claims transmitting signals to very specific parties, with very specific information, and yielding very specific results:

transmitting to the communications device a second signal including data that prompts an automated message to be communicated to a user of the communications device, the automated message representing a notice communicating to the user of the communications device that the location information of the communication device will be obtained; and

transmitting a fourth signal to a location information provider, the fourth signal including data representing a request for location information of the communications device, wherein the location information provider corresponds to a party or device other than the communications device and the location information provider corresponds to at least one of: a wireless service provider providing wireless service to the communications device, a third party that obtains the location information of the communications device from the wireless service

provider providing wireless service to the communications device, and a party that has access to the location information of the communications device but is other than the wireless service provider or the third party that obtains the location information of the communications device from the wireless service provider.

(‘943 patent at 21:1-29.) The first limitation requires that a signal is transmitted to a communications device that prompts an automated message that notifies the user of the device that location information for the device will be obtained. The second limitation requires that a signal is transmitted to a specifically defined “location information provider,” which requests the location of the communications device. FourKites’ reduction of these two limitations recited above to simply “sending” demonstrates the futility of its arguments. In fact, claim 1 alone includes an additional six limitations above and beyond the two listed above. Again, FourKites treatment of the claims of the patents-in-suits can in no way meet the standards for finding claims invalid as set forth in *Alice*.

Further, not only does FourKites’ oversimplified characterization of the claims of the patents-in-suit hide meaningful limitations of the claims, it also obscures the import of those limitations. For example, claim 1 of the ‘943 patent provides that the freight’s current location is obtained not by a direct query as to where the freight is located, but by an indirect query to a location information provider as to the location of a communications device, which is correlated to the freight. (*See* ‘943 patent at 20:65; 21:30-36; 22:15-23; and 35-38.) The ‘943 patent’s detailed description discloses these limitations and explains their technical importance. For example, the ‘943 patent discloses the cost savings of indirect location monitoring which does not require the purchase and installation of dedicated monitoring equipment in each vehicle. (*See, e.g., id.* at 1:26, 33-45.)

Moreover, FourKites’ analysis is inaccurate. FourKites asserts that the “claims of the patents-in-suit are directed to the basic idea of tracking freight: (1) receiving a request for the

location of freight; (2) *asking the truck in possession of that freight where it is*; and (3) reporting the location of the truck.” (Mot. To Dismiss, D.I. 18, at p. 14, emphasis added.) The claims of the patents-in-suit do not “ask a truck in possession of freight where it is.” As previously discussed, location information of the communications device is obtained from the location information provider to indirectly determine location of a vehicle or freight. The claims specifically define what is a location information provider, and it clearly is not a truck as FourKites misleadingly asserts. Therefore, not only is FourKites’ analysis cursory, simplistic, and unpersuasive, it is just plain wrong.

In evaluating the patents at issue in *Alice v. CLS Bank*, the Federal Circuit stated that an abstract idea is a “disembodied concept ... untethered from any real-world application.” *CLS Bank Int’l v. Alice Corp. Pty*, 717 F.3d 1269, 1286 (Fed. Cir. 2013) (internal citation and quotations omitted). Even the most cursory examination of the claims of the patents-in-suit reveals that the subject matter claimed is very much tethered to real-world applications by limiting the claims to indirectly obtaining location information of a communications device from a location information provider and correlating that information to a vehicle or freight, providing notification, obtaining consent, and other operational functions and advantages. The claims may be directed to tracking freight, but the claims are not directed to the general idea of tracking freight or the only way to track freight. Instead, the claims are directed to specific ways of tracking freight that differ from and provide benefits over the prior art.

FourKites’ cited authorities do not advance its arguments for invalidating the claims of the patents-in-suit. Any comparison of the challenged claims here to the claims at issue in the decisions cited by FourKites reveal dramatic differences between the claims of the patents-in-suit and the claims found invalid in the cases cited by FourKites. For instance, in *Alice* the claims

were directed to the fundamental economic practice of intermediate settlement; in *Bilski* the claims were directed to another fundamental economic practice of hedging of risk; in *Mayo*, the claims were directed to a law of nature regarding the administration of a drug, and in *Ultramercial* the claims were directed to using advertising as an exchange or currency.

All of the cases cited by FourKites, with the exception of *Mayo*, are directed to subject matter that can be characterized as “business methods.” The identified “ideas” of these patents are in stark contrast to the claims of the patents-in-suit. Judge Mayer of the Federal Circuit, in his concurring opinion in *Ultramercial*, stated that *Alice* “for all intents and purposes, set out a technological arts tests for patent eligibility.” *Ultramercial, Inc.* 772 F.3d at 717. Judge Mayer contrasted technological arts with “entrepreneurial” ones. *Id.* Indeed, most post-*Alice* validity decisions are so distinguished, with business method patents bearing the greatest scrutiny, while patents directed to the technological arts surviving such scrutiny.

Unlike the cases cited in FourKites’ Motion, cases in which claims were directed to technological arts generally survive the two-part *Alice* test. In *DDR Holdings, LLC v. Hotels.com. L.P.*, 773 F.3d 1245 (Fed. Cir. 2014), the Federal Circuit held that a patent directed to an e-commerce outsourcing system for serving web pages offering commercial opportunities is patent-eligible subject matter under 35 U.S.C. § 101. *Id.* at 1259. “These claims stand apart because they do not merely recite the performance of some business practice known from the pre-Internet world along with the requirement to perform it on the Internet. Instead, the claimed solution is necessarily rooted in computer technology in order to overcome a problem specifically arising in the realm of computer networks.” *Id.* at 1257.

In *Messaging Gateway Solutions, LLC v. Amdocs, Inc.*, 2015 U.S. Dist. LEXIS 49408 (D. Del. Apr. 15, 2015), the patent at issue is directed to methods for using a computer system to

facilitate two-way communication between a mobile device and an internet server. *See id* at \*7. The patent “is directed to a problem unique to text-message telecommunication between a mobile device and a computer. The solution it provides is tethered to the technology that created the problem.” *Id* at 15-16. The court found that like in *DDR Holdings*, the claim at issue “is necessarily rooted in computer technology in order to overcome a problem specifically arising in the realm of computer networks.” *Id.* at 15.

Here, the claims of the patents-in-suit is securely tethered to a tangible idea of a particular way to obtaining the location of a vehicle or freight. Thus, the patents-in-suit are directed to patent-eligible subject matter.

3. The Claims of the Patents-in-Suit Pass the Second Part of the *Alice* Test

Although FourKites has failed to satisfy the first part of the *Alice* test, consideration of the second part of the *Alice* test further demonstrates the insufficiency of FourKites’ arguments. The second part requires that, if the claims are directed to a patent ineligible abstract idea, the elements of each claim are considered—both individually and as an ordered combination—to determine whether the additional elements transform the nature of the claim into a patent-eligible application of that abstract idea. *Alice*, 134 S. Ct. at 2355. This second part is a search in the claims for an “inventive concept.” *Id.* The “inventive concept” ensures that the claims at issue amount to “significantly more” than a patent on the ineligible concept itself. *Id.*

Federal Circuit Judge Mayer in his concurring opinion in *Ultramercial* explained, in order to satisfy the technological arts tests set forth in *Alice*, “claims must harness natural laws and scientific principles ... [and] use them to solve seemingly intractable problems.” *Ultramercial*, at 721-722. The Federal Circuit’s *DDR Holdings* decision highlights the importance of solving a technological problem in the second part of the *Alice* test in determining whether the claims individually and as a whole recited an inventive concept. *DDR Holdings*,

773 F.3d at 1255-59. The claims of the patents-in-suit include a number of inventive concepts.

a. A First Inventive Concept – Correlation of Location Information of a Communications Device to Location of the Freight or a Vehicle

The patents-in-suit disclose that “[c]onventional systems for monitoring vehicle location have relied on global positioning systems (GPS) to provide the vehicle's location. Moreover, some of these systems require the installation of additional dedicated equipment in each vehicle.” (See ‘943 patent at 1:31-36.) These systems required each vehicle to have a dedicated GPS receiver installed in the vehicle. (*Id.*) This is a costly proposition and, as such, many vehicles carrying freight do not have a GPS receiver attached to the vehicle. Even within a single freight company, some vehicles may be equipped with GPS receivers while others are not. The technological challenge is how to monitor the location of the freight or vehicle by technical means other than a dedicated GPS receiver installed in the vehicle.

The claims of the patents-in-suit include the inventive concept of correlating the location information of a communications device with the location of freight or a vehicle. For example, claim 1 of the ‘943 patent recites the following limitations:

correlating the freight to a communications device;

receiving a first signal including data representing a request for information regarding the location of the freight;

transmitting a fourth signal to a location information provider, the fourth signal including data representing a request for location information of the communications device, wherein the location information provider corresponds to a party or device other than the communications device and the location information provider corresponds to at least one of . . . :

receiving a fifth signal from the location information provider, the fifth signal including data representing the location information of the communications device;

correlating the location information of the communications device to the location of the freight based at least in part on the correlation between the freight and the communications device; and

transmitting a sixth electronic signal including data representing the location of the freight.

(‘943 patent at 20:63-21:38.)

Claim 1 provides a technical solution to the technical problem of how to monitor the location of the freight or vehicle by technical means other than a dedicated GPS receiver installed in the vehicle. This is accomplished by discerning the location of the freight or the vehicle without requiring a dedicated GPS receiver installed in the vehicle. The technical solution of claim 1 discerns the location of the freight or the vehicle by obtaining the location of a communications device from a location information provider and correlating the communication device’s location information to that of the freight or vehicle.

Additionally, claims 2 and 3 of the ‘943 patent respectively recited:

the location information of the communications device is originally obtained using a method including a technique other than a technique utilizing a global position system (GPS) satellite receiver that forms part of the communications device; and

the location information of the communications device is originally obtained using a method including at least one of: advance forward link trilateration (AFLT), observed time difference (OTD), Cell-ID (CID), and a range of locations corresponding to a transmission range of a single radio tower.

(*See also* claims 3 and 4 of the ‘295 patent, claim 4 of the ‘097 patent, claims 3-4 and 13-14 of the ‘098 patent and claim 4 of the ‘313 patent.)

The claims provide technical solutions to the technical problem regarding how to monitor the location of freight or vehicles by means other than a dedicated GPS receiver installed in the vehicle and the claims set out precise sets of instructions for achieving the solution. Thus, the claims provide an inventive concept above and beyond a mere abstract idea.

Further, the PTO found that the claims included an inventive concept. Among its Reasons for Allowance, the PTO states that the prior art of record fails to teach or render obvious, alone



or in combination, the unique claim combinations including, for the '295, '097, '098, and '313 patents:

correlating the location information of the communications device to the location of the at least one of the vehicle or the freight carried by the vehicle based at least in part on the correlation of the at least one of the vehicle or the freight carried by the vehicle to the communications device; and transmitting a location signal including data representing the location of the at least one of the vehicle or the freight carried by the vehicle.

(See Ex. 5 at p. 9.) Through this statement, the PTO indicates that these aspects of the claims are inventive. This inventive concept provides “substantially more” than just the purportedly abstract idea of “tracking freight with a computer.”

b. A Second Inventive Concept – Obtaining Location Information of Communications Device from a “Location Information Provider” – a Party or Device Other than the Communications Device.

Another technical problem to be solved is handling trucks and drivers of trucks that do not have uniform equipment. Some trucks are equipped with dedicated GPS units and some are not. Some truck drivers carry smartphones, while other truck drivers carry older cell phones (such as a “flip phone”). Each of these categories of devices use different techniques to facilitate location tracking. GPS units use GPS techniques; flip phones, which do not have a GPS receiver, use cellular techniques; and smartphone can use a mixture of GPS, cellular and wireless techniques. Due to the nature of GPS location systems, determining location via GPS is not always reliable. For example, a truck and hence the GPS unit or smartphone may be indoors (e.g., warehouse, hangar, etc.), under a bridge or in some other location where satellite reception is limited or impossible. It is advantageous for a system to not only include GPS techniques, but also include additional techniques so that flip phones and smartphones can be efficiently used for location tracking.

Hence, the additional technical challenges that needed to be solved included: 1) how to

monitor the location of the freight or vehicle by technical means that do not rely exclusively on GPS; and 2) how to manage multiple channels providing location information (*i.e.*, dedicated GPS units, smartphones, flip phones, etc.).

The claims of the patents-in-suit provide a technical solution to the additional technical challenge. Importantly, the claims recite that the location information of the communications device is obtained from “a location information provider,” which is defined in the claims as “a party or device other than the communications device.” (*See e.g.*, ‘098 patent, claims 1 and 2, 21:11-15 and 21:30-42.) This technical solution allows for obtaining location information from multiple channels, and reducing reliance on GPS-enabled equipment and GPS techniques, resulting in a more robust and inclusive system. Many of the independent and dependent claims go on to further define the “location information provider” and who or what, other than the communications device itself, is a location information provider. The Specification of the patents-in-suit disclose detail regarding the claimed “location information provider.”

This technical solution to the technological challenge – namely, how to monitor the location of freight or vehicles by technical means without relying directly on receiving GPS-based information to determine location of freight or a vehicle – corresponds to an additional inventive concept.

c. Third Inventive Concept – Providing Notice and/or Consent to the User that Location Information of the Communications Device is being Obtained

Once the location information of a communications device is obtained, specific privacy concerns and general awareness of privacy issues necessitated a solution that did not apply to prior art freight tracking systems,<sup>10</sup> thus, presenting a new technical challenge that required a

---

<sup>10</sup> Privacy concerns were not applicable to prior art freight tracking systems because these systems were mostly closed proprietary systems in which the party monitoring location owned the vehicles or otherwise had explicit right

new technical solution. The privacy concerns are discussed at some length in the Specification of the patents-in-suit. Essentially, privacy expectations require that the user be given notice that the location information of his or her communications device is to be obtained and that the user provides consent to the collection and use of the location information.

Providing notice to and obtaining consent from each user, whether an individual driver with a flip phone or smartphone or a trucking company with dedicated GPS devices on each truck, became a technical challenge requiring a novel solution. Creating a system that manually or automatically called each user individually to provide notice and consent would have substantially hampered the utility of the invention. There could be thousands of users and many thousands of transactions making such a consent mechanism prohibitively inconvenient. Thus, a technical challenge arose requiring a new solution — how to provide notice to and receive consent from all users in an efficient manner and in accordance with certain guidelines for smartphone users.

The claims of the patents-in-suit provide that technical solution to the additional technical challenge. For example, claim 1 of the '943 patent provides:

signal including data that prompts an automated message to be communicated to a user of the communications device, the automated message representing a notice communicating to the user of the communications device that the location information of the communications device will be obtained; and

signal including data indicative of consent from the user to the obtaining of the location information of the communications device.

Several of the dependent claims further define how consent may be obtained from the user of the communications device. The Specification of the patents-in-suit also provide much detail regarding the providing notice and obtaining consent of the claims.

---

to monitor location of the freight or the vehicle. The inventive concept opened up location data to clients of the trucking company, shipper, brokers, etc. which raises privacy concerns.

The PTO agrees that the technical solution to the technological challenge of how to provide notice to and receive consent from the user according to the guidelines in an efficient manner corresponds to an inventive concept. Among its Reasons for Allowance, the PTO states that the prior art of record fails to teach or render obvious, alone or in combination, the unique claim combinations including, for the '943 patent:

a notification logic configured to generate a notification signal including data representing a notice indicating to the user of the communications device that consenting to revealing location of freight carried by the vehicle would result in the location information of the communications device being disclosed, wherein the communications interface is further configured to: transmit a fifth electronic signal to the communications device, the fifth electronic signal including at least one of the notification signal and data representing a request for the consent of the user of the communications device to revealing the location information of the communications device, and receive a sixth electronic signal including data representing the consent of the user of the communications device to revealing the location information of the communications device.

(See Ex. 5 at p. 2.) For the '295, '097, '098, and '313 patents:

receiving a signal including data that indicates that a user of a communications device consented to transmission of location information of the communications device.

(See Ex. 5 at p. 9.) These statements are clear indications by the PTO that the notification and consent aspects of the claims are inventive; *i.e.*, the prior art does not “teach or render obvious, alone or in combination, the unique claim combinations.”

This technical solution to the technological challenge of how to provide notice to and receive consent from all users in an efficient manner and in accordance with users' expectations corresponds to an additional inventive concept that provides substantially more than “tracking freight with a computer.” This inventive concept, as in *DDR Holdings*, provides a solution to a technical problem that is unique and “tethered to the technology that created the problem.” *DDR Holdings*, 773 F.3d at 15-16.

Each of these three technical solutions explained above *by itself* provides an “inventive

concept” that is separate from and beyond the concept of “tracking freight with a computer,” and thus, provides “substantially more” as prescribed by *Alice*. That the asserted claims here provide not one but at least three inventive concepts conclusively put to rest the § 101 patentable subject matter issue. The claims of the patents-in-suit are patent-eligible subject matter.

#### **IV. CONCLUSION**

For the foregoing reasons, MacroPoint respectfully requests that the Court deny FourKites’ Motion to dismiss the First Amended Complaint.

Dated: September 15, 2015

Respectfully submitted,

/s/Risto Pribisich

Risto Pribisich (0081758)

Michael Sherban (0079950)

BENESCH, FRIEDLANDER, COPLAN &  
ARONOFF LLP

200 Public Square

Suite 2300

Cleveland OH 44114 2378

Telephone: (216) 363 4500

Facsimile: (216) 363-4588

Email: rpribisich@beneschlaw.com

Email: msherban@beneschlaw.com

Timothy J. Coughlin (0019483)

Carolyn M. Cole (0092530)

THOMPSON HINE LLP

3900 Key Center

127 Public Square

Cleveland, Ohio 44114

Telephone: (216) 566-5500

Facsimile: (216) 566-5800

Email: tim.coughlin@thompsonhine.com

Email: hope.lu@thompsonhine.com

*Attorneys for Plaintiff MacroPoint, LLC*

**CERTIFICATION**

The present case has not yet been assigned to a track. The Court granted a motion on July 31, 2015, granting permission for this Memorandum filed in opposition to Defendant's Motion to Dismiss the First Amended Complaint to be up to thirty pages in length. The undersigned hereby certifies that the length of this Memorandum complies with the Court's Order.

*/s/Risto Pribisich*  
\_\_\_\_\_  
*One of the Attorneys for Plaintiff*  
MacroPoint, LLC

**CERTIFICATE OF SERVICE**

A copy of the foregoing is being filed this 15th day of September, 2015 and is being served upon counsel of record by operation of the Court's electronic filing system.

/s/Risto Pribisich  
*One of the Attorneys for Plaintiff*  
MacroPoint, LLC



3

Zatkovich

Declaration of Ivan Zatkovich  
in Support of MacroPoint,  
LLC's Opposition Brief to  
Defendant FourKites, Inc.'s  
Motion to Dismiss First  
Amended Complaint

# **EXHIBIT 3**

**IN THE UNITED STATES DISTRICT COURT  
FOR THE NORTHERN DISTRICT OF OHIO  
EASTERN DIVISION**

---

**MacroPoint, LLC,**  
Plaintiff,

vs.

**FourKites, Inc.,**  
Defendant.

---

CASE NO.: 1:15CV1002

JUDGE PATRICIA A. GAUGHAN

**DECLARATION OF IVAN ZATKOVICH IN SUPPORT OF MACROPOINT, LLC'S  
OPPOSITION BRIEF TO FOURKITES, INC.'S MOTION TO DISMISS  
FIRST AMENDED COMPLAINT**

DECLARATION OF IVAN ZATKOVICH IN SUPPORT OF MACROPOINT, LLC'S OPPOSITION  
BRIEF TO FOURKITES, INC.'S MOTION TO DISMISS FIRST AMENDED COMPLAINT

TABLE OF CONTENTS

<b>I.</b>	<b>INTRODUCTION.....</b>	<b>5</b>
<b>II.</b>	<b>BACKGROUND AND QUALIFICATIONS .....</b>	<b>6</b>
<b>III.</b>	<b>LEGAL STANDARDS .....</b>	<b>10</b>
A.	Subject Matter Eligibility under 35 U.S.C. § 101 .....	10
<b>IV.</b>	<b>SUMMARY OF MY STUDY .....</b>	<b>11</b>
<b>V.</b>	<b>ONE OF ORDINARY SKILL IN THE ART.....</b>	<b>12</b>
<b>VI.</b>	<b>TECHNICAL BACKGROUND.....</b>	<b>13</b>
A.	The Technology .....	13
i.	Early Methods.....	13
ii.	1990's – Company Exclusive Technology .....	13
iii.	Shared Infrastructure - Consent .....	16
B.	Exemplary Industry: Fleet Tracking .....	18
i.	Conventional fleet tracking systems .....	18
ii.	Conventional system architecture .....	20
iii.	Active vs. Passive location devices on conventional systems (i.e. Discrete location tracking vs. continuous tracking).....	21
iv.	Single channel communication and closed systems .....	22
v.	The disadvantages of the conventional systems (are also the problems solved by the MacroPoint patents).....	24
<b>VII.</b>	<b>OVERVIEW OF THE PATENTS IN SUIT.....</b>	<b>24</b>
A.	Conventional Systems.....	24
i.	Conventional: Closed Systems .....	24
ii.	Conventional: Single Channel Communication.....	26
iii.	Conventional: Single / Homogeneous Location Technology .....	27
iv.	Conventional: Discrete Location Points .....	28
B.	Invention of the MacroPoint Patents: Unconventional.....	29
i.	Comparison Chart – Conventional vs. Unconventional .....	29
ii.	The use of a third party Location Information Provider make the MacroPoint invention Unconventional.....	30
iii.	The MacroPoint Patents teach an Open System .....	35
iv.	The MacroPoint Invention Utilizes Heterogeneous Locating Technology .....	37
v.	The MacroPoint Invention enables Continuous Monitoring .....	40
vi.	The MacroPoint Invention creates a Hub based Network for Multi-Channel Communication.....	41
vii.	The MacroPoint Invention Incorporates Consent-Based Privacy.....	44
C.	Technical Problems to Be Solved with Technical Solutions .....	50
<b>VIII.</b>	<b>THE CLAIMS ARE DIRECTED TO PATENT-ELIGIBLE SUBJECT MATTER</b>	<b>54</b>

DECLARATION OF IVAN ZATKOVICH IN SUPPORT OF MACROPOINT, LLC’S OPPOSITION  
 BRIEF TO FOURKITES, INC.’S MOTION TO DISMISS FIRST AMENDED COMPLAINT

A. USPTO Two-Part Test..... 54

B. Part 1 of the *Mayo* test: The Claims of the MacroPoint Patents are Directed to A Novel and Patent Eligible Open System Architecture and not simply to the “Abstract Idea of Freight Tracking.” ..... 57

    i. All independent claims contain concrete and tangible elements ..... 58

    ii. System independent claims contain additional concrete and tangible elements ..... 60

    iii. All independent claims have dependent claims that contain additional concrete and tangible elements ..... 61

    iv. The claims are not directed to an abstract idea. .... 63

C. Part 2 of the *Mayo* test: The Claims of the MacroPoint Patents also amount to significantly more than “An Abstract Idea of Freight Tracking” with the addition of an Unconventional Open System Architecture. .... 63

    i. Using a third party Location Information Provider creates an “open system” for access by multiple parties..... 64

    ii. Using a Hub based Network provides a Multi-channel communication .. 67

    iii. The third party Location Information Provider allows Heterogeneous location technology ..... 69

    iv. Automated response provides consent and continuous capture of location information for real-time monitoring..... 71

    v. The claims amount to significantly more than an abstract idea..... 72

**IX. REBUTTAL TO DEFENDANT’S ASSERTIONS.....73**

A. MacroPoint Patents teach significantly more than organizing human activity (*Cybersource*) ..... 73

B. MacroPoint Patents teach significantly more than sending, receiving, and correlating (*Ultramercial*)..... 75

C. MacroPoint claims are not like *Wireless Media Innovations* Freight Monitoring claims ..... 78

D. Implementation on Computer - *Alice*..... 80

E. Generic Computer Components..... 84

F. Inventive Concepts of the MacroPoint Patents – Technical Solutions to Problems Rooted in Technology ..... 84

**X. COMPARISONS OF THE MACROPOINT PATENT ELIGIBLE EXAMPLES ...89**

A. The MacroPoint Patents Address Technical Problems Requiring a Technical Solution (*DDR Holdings*) ..... 90

    i. Using a third party Location Information Provider to create an “open system” for access by multiple parties..... 94

    ii. Creating a Hub based Network to provide a Multi-channel communication for the multiple requestors and receivers. .... 94

    iii. Technical Requirement for Heterogenous Location Technology ..... 95

    iv. Providing Automated response allows for consent and continuous capture of location information for real-time monitoring..... 96

DECLARATION OF IVAN ZATKOVICH IN SUPPORT OF MACROPOINT, LLC'S OPPOSITION  
BRIEF TO FOURKITES, INC.'S MOTION TO DISMISS FIRST AMENDED COMPLAINT

B. The MacroPoint claim limitations impose meaningful limitations in the field of  
Freight Tracking (SiRF Technology)..... 97

XI. SIGNATURE.....99

DECLARATION OF IVAN ZATKOVICH IN SUPPORT OF MACROPOINT, LLC'S OPPOSITION  
BRIEF TO FOURKITES, INC.'S MOTION TO DISMISS FIRST AMENDED COMPLAINT

I, Ivan Zatkovich, hereby declare:

**I. INTRODUCTION**

1. I have been retained by Counsel for MacroPoint, LLC ("MacroPoint") to provide opinions on subject matter eligibility issues concerning the claims of U.S. Patent Nos. 8,604,943, entitled, "Systems and Methods for Monitoring Location of Freight Carried by a Vehicle" (the "943 Patent"); 9,070,295, entitled "Systems and Methods for Monitoring Location of a Vehicle or Freight Carried by the Vehicle by Correlating the Vehicle or the Freight Carried by the Vehicle to a Communications Device" (the "295 patent"); 9,082,097, entitled "Systems and Methods for Monitoring Location of a Vehicle or Freight Carried by a Vehicle" (the "097 patent"); 9,082,098, entitled "Systems and Methods for Monitoring Location of a Vehicle or Freight Carried by a Vehicle" (the "098 patent"); and 9,087,313, entitled "Systems and Methods for Monitoring Location of a Vehicle or Freight Carried by a Vehicle" (the "313 patent") (collectively, referred to as "MacroPoint patents" or, "Patents-in-suit").

2. I am aware that FourKites, Inc. ("FourKites") has filed a motion seeking to invalidate the MacroPoint Patents, asserting that the claims of the MacroPoint Patents are directed to ineligible subject matter under 35 U.S.C. § 101.

3. I have been asked to opine on the subject matter eligibility of the MacroPoint patents under 35 U.S.C. § 101 in light of the legal guidance provided by attorneys for MacroPoint and my evaluation of the claims of the MacroPoint patents. My opinions are set forth below. I make these statements based upon facts and matters within my own knowledge or on information provided to me by others. All such facts and matters are true to the best of my knowledge and belief.

DECLARATION OF IVAN ZATKOVICH IN SUPPORT OF MACROPOINT, LLC'S OPPOSITION  
BRIEF TO FOURKITES, INC.'S MOTION TO DISMISS FIRST AMENDED COMPLAINT

## II. BACKGROUND AND QUALIFICATIONS

4. A copy of my curriculum vitae is attached as Exhibit 1 to this declaration, with a list of cases where I have been retained in the past five years as Exhibit 2.

5. I received a Bachelor's degree in Computer Science, with a minor in Electrical Engineering Digital Circuit Design, from the University of Pittsburgh in 1980. I completed a Master's thesis in Computer Networks in 1981 at the University of Pittsburgh, the results of which were published in Byte Magazine. My Master's thesis involved designing a heterogeneous network architecture that allowed substantially different computer systems to communicate with a common command interface. The primary application used to test the network was a search game that allowed multiple players on different computers to navigate through a shared matrix. The application maintained a common database of player locations across all computers in real time.

6. I have over 30 years of experience in computer science and computer network architecture involving a diverse set of implementations including Telecommunication, CTI (Computer Telephony Integration), early wireless/cell phone communication, booking and provisioning systems. I specialize in systems for eCommerce, Geolocation, Supply Chain, and Logistics.

7. I have been a Principal Consultant with eComp Consultants for over ten years. eComp Consultants provides professional consulting services relating to computer and technical matters in a wide range of industries including embedded Internet systems, cellular telephony, and cloud-based services. Such consulting services include working with clients, such as



DECLARATION OF IVAN ZATKOVICH IN SUPPORT OF MACROPOINT, LLC'S OPPOSITION  
BRIEF TO FOURKITES, INC.'S MOTION TO DISMISS FIRST AMENDED COMPLAINT

Amazon.com, Microsoft, GEICO, Verizon, and McGraw-Hill, on specific information technology projects, process improvement, project management, and other technology issues.

8. At eComp Consultants, I have been frequently called upon to provide my expert opinion on matters concerning patent disputes. I have been qualified as a technical expert in over 24 matters and have specifically analyzed and testified about computer systems for managing and tracking shipments and supply chain and logistics management. A complete list of the cases in which I have testified in the last five years is included in Exhibit 1.

9. In my professional career, I have worked for companies such as Digital Equipment Corp., GTE Data Services (now Verizon), and Eva-Tone, Inc. on projects designing, developing, and integrating software and hardware for major computer and telecommunications systems and networks and on projects designing and developing eCommerce, content management, and web publishing systems.

10. I worked for Digital Equipment Corp. from approximately 1980 until 1987. There I designed and developed computer models that could simulate a manufacturer's supply chain, including tracking the status of the delivery of parts and other goods. I also designed a computer network that could handle Just-in-Time (JIT) ordering and shipping. I also designed and developed the communications drivers to operate within the DECNet architecture. This work also involved designing and implementing relational databases that could handle the complex workflow required for JIT order and shipping. The workflow structure was based on the MAPP standard where each Workcell anticipated required parts orders and projected shipping lead-times.

DECLARATION OF IVAN ZATKOVICH IN SUPPORT OF MACROPOINT, LLC'S OPPOSITION  
BRIEF TO FOURKITES, INC.'S MOTION TO DISMISS FIRST AMENDED COMPLAINT

11. I worked for GTE Data Services (now Verizon) from approximately 1987 until 1996. There I worked on designing the network architecture for a communications system that had service provisioning and service booking capabilities. I also designed and developed automated Geolocation, and geographic mapping applications including truck routing for customer services and Facilities management.

12. I worked for Eva-Tone, Inc. from approximately 2002 until 2007. There I designed and implemented systems for enterprise resource planning and supply chain management. My work also entailed designing and implementing an eCommerce system that allowed the company to book shipments using a variety of carriers and transport modes, including bulk, drop shipping, and container shipping, and manage and track shipments being handled by multiple carriers. Another eCommerce system I designed and implemented for Eva-Tone's customer, Pro Marine USA, required developing separate interfaces to different freight carriers (e.g. UPS, FedEx, USPS) since each carrier implemented a separate API to access their in-house carrier systems. I understand that this system is still in use today.

13. Specific projects I have developed or managed that are related to this matter include:

- **Verizon** – Designed and developed Automated Geolocation, Geographic mapping and Facilities Management system based on Customer & Equipment location.
- **GIS Dispatch Mapping (AWAS)** – Implemented Geographic based mobile field services for locating subscribers and displaying routing information on a geographic map.
- **Utility Partners** – Developed the MobileUP application, a geographic work order and vehicle tracking system for dispatching Field Service personnel and managing Electronic Onboard Recording.

DECLARATION OF IVAN ZATKOVICH IN SUPPORT OF MACROPOINT, LLC'S OPPOSITION  
BRIEF TO FOURKITES, INC.'S MOTION TO DISMISS FIRST AMENDED COMPLAINT

- **eComp Consultants** – Location based mobile applications –
- **Mobile Payments** – developed patents for mobile payment and advertising. Technology includes NFC (Near Field Communication) and SMS based transaction authorization. (Android, iPhone)
- **Cell Mesh Networks** – developed Mesh Network for hyper-local marketing and mobile applications incorporating transaction security, geolocation, and WiFi direct connect technology (Android, iPhone)

14. I have been retained as a testifying expert on the following matters related to geolocation and vehicle tracking:

- **GT Nexus v. INTTRA – Patent Litigation** - Testifying expert providing expertise in systems for Location and Tracking of Cargo and Container shipments. Provided declaration to rebut an Alice/101 DJ motion challenging Patentable subject matter.
- **State Farm v. Progressive - (CBM) Covered Business Method** - Expert providing expertise in Electronic OnBoard Recording devices to allow Vehicles to record and transmit vehicle location, status, and other characteristics. Provided expert report including rebuttal of a 101 Patentable subject matter challenge.
- **Geotag v Nordstrom, Godiva, et.al. – Patent Litigation** – Testifying expert for 12 defendants for web and mobile based Geolocation applications to identify proximity to and location of Merchants.
- **Black Hills v. Samsung et.al. – ITC Patent Litigation** – Analysis of Mobile based location sharing and event driven mobile applications such as AT&T FamilyMap, Google+ Location, and Latitude. Providing infringement assertions against Samsung, LG, and Toshiba (smart phones & mobile tablets).

15. By virtue of at least the above education and experiences, I have gained a detailed understanding of the technology that is the subject of my Declaration. For example, my experience with computer network architecture design and implementation and systems for managing shipments, including tracking and tracing systems, is relevant to the subject matter of the MacroPoint Patents. As such, I am qualified to provide opinions regarding the state of the art

DECLARATION OF IVAN ZATKOVICH IN SUPPORT OF MACROPOINT, LLC'S OPPOSITION  
BRIEF TO FOURKITES, INC.'S MOTION TO DISMISS FIRST AMENDED COMPLAINT

at the time of the invention (March 2012), how one of ordinary skill in the art at that time would have interpreted and understood the MacroPoint Patents, and the subject matter eligibility of the claims of the MacroPoint Patents under 35 U.S.C. § 101.

### III. LEGAL STANDARDS

#### A. Subject Matter Eligibility under 35 U.S.C. § 101

16. I understand that through decisions such as *Alice Corp. v. CLS Bank Int'l*, 134 S. Ct. 2347 (2014) and *Mayo Collaborative Servs. v. Prometheus Labs, Inc.*, 132 S. Ct. 1289 (2012), the Supreme Court has established a two-part test to distinguish between patents that claim laws of nature, natural phenomena, and abstract ideas from patents that claim patent-eligible applications of these concepts.

17. I understand that step one of the test is to determine if the claims at issue are directed to a patent-ineligible concept such as an abstract idea. Although I understand that there is no explicit definition of what qualifies as an abstract idea, I understand it can include “fundamental economic practices,” “methods of organizing human activity,” and “an idea of itself.” If the claims are directed to a patent-ineligible concept, I understand that the second step is an analysis of the claims at issue to determine if the limitations of the claims amount to “significantly more” than the ineligible concept itself. This analysis determines whether additional elements of each claim—both individually and as an ordered combination—transform the nature of the claim into a patent-eligible application of that abstract idea.

18. I also understand that this second step is sometimes described as a search for an “inventive concept” where some element or combination of elements sufficiently ensure that the claim in practice does amounts to significantly more than a patent on an ineligible concept. To

DECLARATION OF IVAN ZATKOVICH IN SUPPORT OF MACROPOINT, LLC'S OPPOSITION  
BRIEF TO FOURKITES, INC.'S MOTION TO DISMISS FIRST AMENDED COMPLAINT

this end, I understand that a claim that recites an abstract idea must include additional features to ensure that the claim is more than a "drafting effort designed to monopolize" the abstract idea, and that claiming an abstract idea while adding the words "apply it with a computer" is insufficient.

19. I further understand that claims that recite an invention that is not merely the routine or conventional use of a generic computer or the Internet have been found to be patent-eligible. I understand that claims that do not broadly and generically claim "use of the Internet" and are "necessarily rooted in computer technology in order to overcome a problem specifically arising in the realm of computer networks" have been found to be patent-eligible.

20. I also understand that the Supreme Court cites examples of patentable subject matter that include: improvements to another technology or technical field; improvements to the functioning of the computer itself; specific limitations other than what is well-understood, routine and conventional in the field; unconventional steps that confine the claim to a particular useful application; and other meaningful limitations beyond generally linking the use of the judicial exception to a particular technological environment.

#### IV. SUMMARY OF MY STUDY

21. In preparing my Declaration, I have:

- Read the MacroPoint Patents and have considered their disclosures and claims from the perspective of a person of ordinary skill in the art.
- Read and reviewed material issued by the United States Patent and Trademark Office regarding examination of claims under 35 U.S.C. § 101 in light of the Supreme Court's *Alice* decision, these materials include:
  - Memorandum regarding Preliminary Examination Instructions in view of the Supreme Court Decision in *Alice Corporation Pty. Ltd. v. CLS Bank International et al.*, issued on June 25, 2014;

DECLARATION OF IVAN ZATKOVICH IN SUPPORT OF MACROPOINT, LLC'S OPPOSITION  
BRIEF TO FOURKITES, INC.'S MOTION TO DISMISS FIRST AMENDED COMPLAINT

- 2014 Interim Guidance on Patent Subject Matter Eligibility, issued on December 16, 2014);
  - USPTO Abstract Idea Examples, issued January 27, 2015;
  - USPTO Abstract Idea Workshop Materials, issued May 2015; and
  - Update on Subject Matter Eligibility and Appendices 1-3, issued on July 30, 2015.
- Read the references submitted by FourKites in support of its Motion to Dismiss First Amended Complaint.

**V. ONE OF ORDINARY SKILL IN THE ART**

22. It is my opinion that the relevant field with respect to the MacroPoint Patents is information systems for geolocation and tracking freight of vehicles carrying freight. In my opinion, a person of ordinary skill in the relevant field in March 2012 would be someone who has a degree in computer science or some other discipline related to information technology and who has a minimum of 3 to 4 years of experience in this field involved with the design or management of a computer network and who has at least some familiarity with the shipping industry and systems for tracking freight.

23. In reaching the opinions contained herein, I have considered the types of problems encountered in the art in March, 2012 the sophistication of the technology, and the education level and professional capabilities of workers in the field at that time.

24. I am a person of ordinary skill in the art under my definition as I possess a Bachelor of Science in Computer Science and performed Masters study in Computer Networking and I have many years of experience designing computer network architecture and implementing

DECLARATION OF IVAN ZATKOVICH IN SUPPORT OF MACROPOINT, LLC'S OPPOSITION  
BRIEF TO FOURKITES, INC.'S MOTION TO DISMISS FIRST AMENDED COMPLAINT

computer systems for eCommerce. Additionally, I have experience in and familiarity with the shipping and tracking industry.

## VI. TECHNICAL BACKGROUND

### A. The Technology

25. The technical background section of the MacroPoint Patents tells the story of how the advance of technology in vehicle and freight tracking introduced challenges that could only be resolved by invention.

#### i. Early Methods

26. The earliest methods of vehicle tracking took place over the telephone. At landmarks such as weigh stations, truck stops and delivery destinations, the driver would call the dispatch office and report their location. The transport company could then respond to customer shipment inquiries by correlating the shipment to the vehicle and reporting the last known check in. Such methods were limited to sporadic use due to the cost of cellular airtime and the nuisance to the driver having to field calls, not to mention the (contrary to what was portrayed in trucker TV shows of the 1970s, citizen band radio (CB) is limited to a range of only a few miles and is not tied into the telephone system.)

27. The introduction of nationwide cellular telephone access in the late 1980s allowed dispatchers to contact drivers directly by placing a call to the driver's cellular phone to inquire their location (i.e. "mile marker X on Interstate Y"). Nevertheless, this did not solve the problem where the dispatcher had to manually log the location of the vehicle based on conversation with the driver. Manual data entry is well known in the art as a point of failure for data accuracy.

#### ii. 1990's – Company Exclusive Technology

DECLARATION OF IVAN ZATKOVICH IN SUPPORT OF MACROPOINT, LLC'S OPPOSITION  
BRIEF TO FOURKITES, INC.'S MOTION TO DISMISS FIRST AMENDED COMPLAINT

28. By the early 1990s computer technology had progressed to the point where companies incorporated automation into vehicle tracking by correlating location with events.

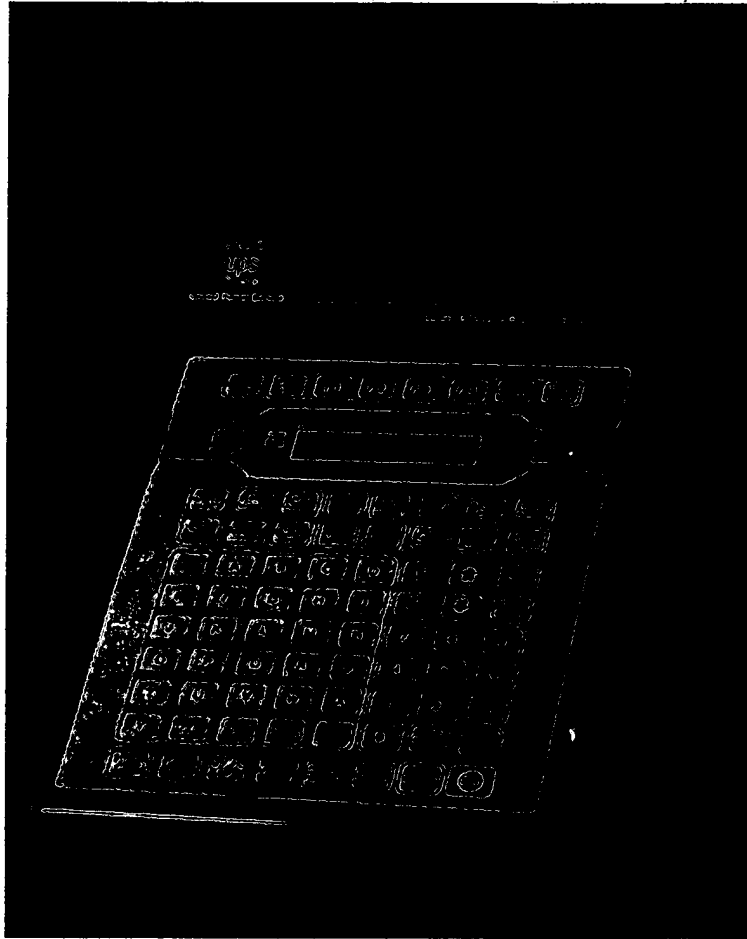

Figure 1 - UPS DIAD circa 1991 [<http://blog.ups.com/2009/12/07/birth-of-the-diad/>]

29. In 1991 UPS developed the Delivery Information Acquisition Device ("DIAD"). The DIAD automated delivery paperwork by capturing signatures, when the driver plugged the DIAD into the base in the truck, it transmitted delivery messages over the cellular network to report a discrete delivery event. By correlating the location of the truck to the last known delivery location, the vehicle could be discretely tracked. The DIAD reduced human data entry errors and increasing the accuracy of data. The DIAD technology was exclusive to UPS.



DECLARATION OF IVAN ZATKOVICH IN SUPPORT OF MACROPOINT, LLC'S OPPOSITION  
BRIEF TO FOURKITES, INC.'S MOTION TO DISMISS FIRST AMENDED COMPLAINT



**HELP IN A HURRY** – Drivers whose cars are equipped with the General Motors OnStar system need not worry about roadside problems, such as medical emergencies. With the press of the red emergency button on the OnStar handset, a priority signal is sent to the 24-hour OnStar Center, where an advisor, using Global Positioning System (GPS) satellite technology and a mapping database, can pinpoint the vehicle, talk to the driver to assess the situation and quickly dispatch the needed emergency service. This is just one of the many safety, security, information and convenience features of the automotive industry's first on-board, integrated services system, available on 1997 Cadillac.

contact Bruce MacDonald  
GM OnStar  
888 W. Big Beaver Rd.  
Troy, MI 48064  
800-70-STAR-1



Figure 2 - 1997 Cadillacs equipped with OnStar (1997 OnStar Press Kit)

30. As GPS technology became readily available in the late 1990s, vehicle location systems evolved from event driven location correlation to the use of GPS coordinates. General Motors introduced the OnStar service in their 1997 Cadillacs [http://articles.chicagotribune.com/1997-03-17/business/9703170156\_1\_onstar-luxury-cars-sensors]. Pressing the OnStar button connects the driver to “the 24-hour OnStar Center, where an advisor, using Global Positioning System (GPS) technology and a mapping database, can pinpoint the vehicle, talk to the driver to assess the situation and quickly dispatch the needed emergency service.” [1997 OnStar Press Kit]

31. Again, each of these early technical tracking systems used company specific technology. With no industry standards in place and a limited number of mobile units per

DECLARATION OF IVAN ZATKOVICH IN SUPPORT OF MACROPOINT, LLC'S OPPOSITION  
BRIEF TO FOURKITES, INC.'S MOTION TO DISMISS FIRST AMENDED COMPLAINT

system, they were costly to maintain to a high degree of reliability. Economies of scale is a well-known term of art wherein the unit cost of delivering service decreases with increasing volume while the quality of each unit increases with increasing volume. Due to company specific technology, individual companies did not have sufficient volume to harvest economy of scale benefits of reduced cost and increased reliability.

**iii. Shared Infrastructure - Consent**

32. By the mid-2000s the proliferation of smartphones with GPS receivers created the environment for cellular carriers to launch Location Based Services ("LBS") as described in the CTIA's Best Practices and Guidelines for Location-Based Services Version 2.0 Effective Date: March 23, 2010 included in FourKites' July 31, 2015 Motion to Dismiss. Cellular technology based services track the location of a cellphone or multiple cellphones within a cellular carrier's network. With millions of cellular subscribers, cellular technology offers greater economies of scale than company specific technology to provide lower unit costs with greater reliability.

33. The advent of LBS's heralded a change from company exclusive technology (although some exclusive systems persist today) to the use of a shared infrastructure where service providers (google, AT&T, etc.) started providing a) automatically generated and collected location information; and b) centralized / shared storage and access to that location information. Where privacy is inherent in company exclusive technology, use of a shared infrastructure requires explicit privacy policies such as the CTIA guidelines (*Id.*).

34. The CTIA Guidelines identifies the requirement for a privacy consent process.  
[CTIA's Best Practices and Guidelines for Location-Based Services Version 2.0 Effective Date:

DECLARATION OF IVAN ZATKOVICH IN SUPPORT OF MACROPOINT, LLC'S OPPOSITION  
BRIEF TO FOURKITES, INC.'S MOTION TO DISMISS FIRST AMENDED COMPLAINT

March 23, 2010, Page 2-6.] either for users subscribing to a service, such as a social networking service, or a business customer (account holder) for tracking their assets.

35. While CTIA Guidelines do not, "dictate the form, placement, terminology used, or manner of obtaining consent as long as the consent is informed and based on notice consistent with the requirements set forth in the Notice..." [Id. p5], the guidelines are directed towards a human being providing the consent. Conventional technology requiring human beings to provide consent fails to meet the needs of an industry where the requirement for consent is immediate, the permission for specific recipients to receive location information is transient and the volume of consent and revocation is large. This technical problem demands a remedy rooted in technology.

36. Users may manifest consent to those terms and conditions electronically by clicking "I accept;" verbally by authorizing the disclosure to a customer service representative; through an IVR system; or through any other system reasonably calculated to confirm consent.

37. In some cases, where the actual user is different than the account holder, an account holder may control the installation and operation of LBS (e.g., business account holder utilizing LBS for fleet management; parental account holder providing phones for children's use). Under these circumstances, the appropriate consent may be obtained solely from the account holder. [CTIA's Best Practices and Guidelines for Location-Based Services Version 2.0 Effective Date: March 23, 2010, Page 5.]

38. Meanwhile, use of cellular technology for vehicle tracking is not a universal solution. Even if all cellular networks could be aggregated for location information delivery, there is no cellular coverage in the ocean and use of cellular on aircraft is prohibited. Moreover,

DECLARATION OF IVAN ZATKOVICH IN SUPPORT OF MACROPOINT, LLC'S OPPOSITION  
BRIEF TO FOURKITES, INC.'S MOTION TO DISMISS FIRST AMENDED COMPLAINT

alternatives to GPS (i.e. GLONASS, LORAN-C, VOR/DME, etc.) and custom company specific vehicle tracking solutions persist. The enduring proliferation of technologies for vehicle tracking is a problem for industries that need a truly universal solution that needs to know where a vehicle is regardless of the kind of vehicle or its location on the earth.

39. An exemplary industry that requires a universal solution with transient needs from carriers for consent to access location information is Fleet Tracking.

**B. Exemplary Industry: Fleet Tracking**

40. Although the specific technology area of the MacroPoint Patents includes "freight tracking", the overall solution of the MacroPoint patents is targeted to fleet tracking. In other words, the proposed unconventional system architecture of the MacroPoint invention does not necessarily just improve the tracking of individual packages or even individual vehicles. The system architecture primarily focuses on improving the overall system and network for tracking fleets of trucks, with thousands of clients or shippers tracking the freight contained in those fleets. Therefore, the following provides a brief summary of the conventional fleet tracking systems.

**i. Conventional fleet tracking systems**

41. Fleet tracking systems are commonly used by fleet operators for fleet management functions such as routing, dispatching, on-board information and security. Along with commercial fleet operators, urban transit agencies use the technology for a number of purposes, including monitoring schedule adherence of buses in service, triggering changes of buses' destination sign displays at the end of the line (or other set location along a bus route), and triggering pre-recorded announcements for passengers.

DECLARATION OF IVAN ZATKOVICH IN SUPPORT OF MACROPOINT, LLC'S OPPOSITION  
BRIEF TO FOURKITES, INC.'S MOTION TO DISMISS FIRST AMENDED COMPLAINT

42. The location technology used in Fleet tracking is usually GPS-based, but sometimes it can be based on GLONASS (similar to GPS), a cellular triangulation platform (to triangulate location between 3 or more cell towers), or Cell-ID (to approximate the location if only one cell tower is accessible), or one of several other methods that have advantages depending on the location and geographic scope to be covered. Potential methods for data transmission include both terrestrial and satellite. Satellite tracking communications, while more expensive, are critical if vehicle tracking is to work in remote environments without interruption.

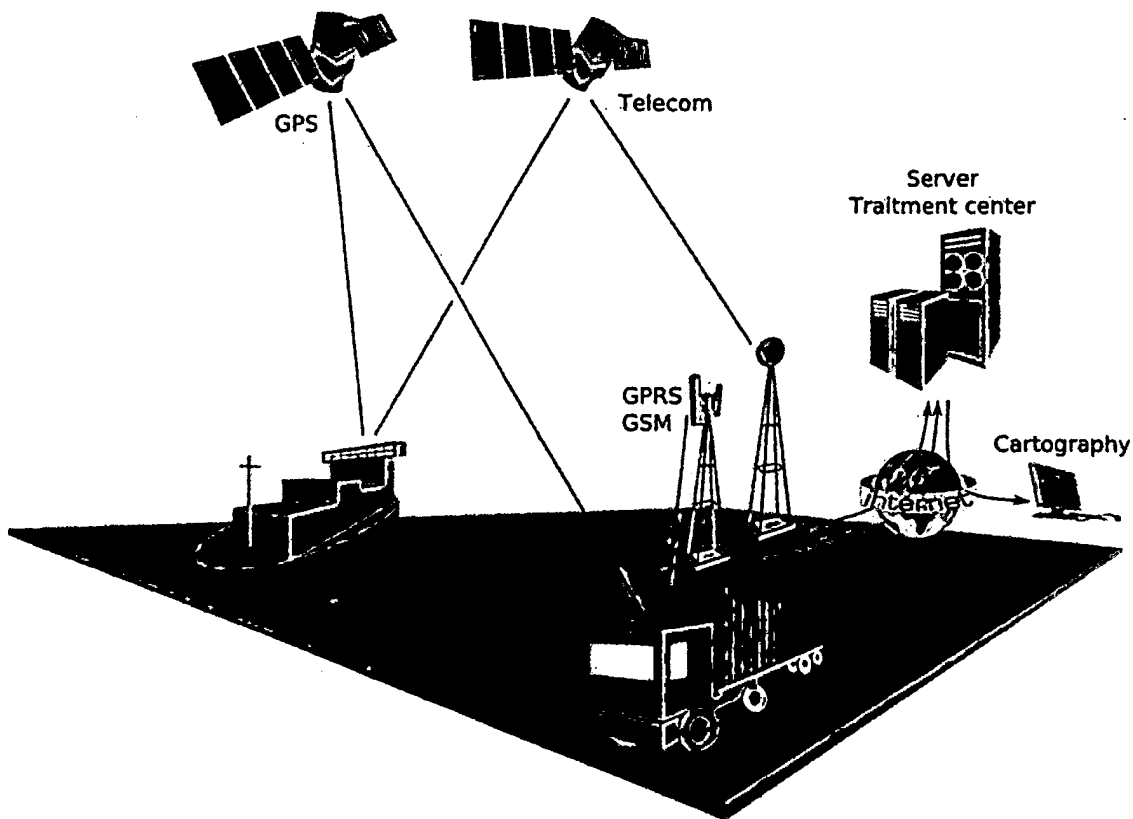

43. This diagram represents a composite of multiple freight companies using multiple location technologies to keep track of each of their respective fleets. Even though it would be ideal for a single freight company to use multiple locations technologies to help track their fleet,

DECLARATION OF IVAN ZATKOVICH IN SUPPORT OF MACROPOINT, LLC'S OPPOSITION  
BRIEF TO FOURKITES, INC.'S MOTION TO DISMISS FIRST AMENDED COMPLAINT

it would not be practical with conventional freight tracking systems. Due to cost, a freight company is generally restricted to a single location technology. Since that is the case, GPS is usually the preferred (default) technology since it tends to work fairly well in a variety of fleet conditions; otherwise other location technologies would be useful to augment the GPS at certain times or in certain locations. However, if expense were not a factor, multiple location technologies (i.e. a mix of heterogeneous location technologies) would be used.

**ii. Conventional system architecture**

44. The following describes the basic components and architecture of a conventional fleet tracking system using the default (GPS) location technology.

- a. GPS tracking device: The device fits into the vehicle and captures the GPS location information apart from other vehicle information at regular intervals to a central server. The other vehicle information can include fuel amount, engine temperature, altitude, reverse geocoding, door open/close, tire pressure, cut off fuel, turn off ignition, turn on headlight, turn on taillight, battery status, GSM area code/cell code decoded, number of GPS satellites in view, glass open/close, fuel amount, emergency button status, cumulative idling, computed odometer, engine RPM, throttle position, GPRS status and a lot more. Capability of these devices actually decide the final capability of the whole tracking system.
- b. GPS tracking server: The tracking server has three responsibilities: receiving data from the GPS tracking unit, securely storing it, and serving this information on demand to the user.

DECLARATION OF IVAN ZATKOVICH IN SUPPORT OF MACROPOINT, LLC'S OPPOSITION  
BRIEF TO FOURKITES, INC.'S MOTION TO DISMISS FIRST AMENDED COMPLAINT

- c. User interface: The UI determines how one will be able to access information, view vehicle data, and elicit important details from it.

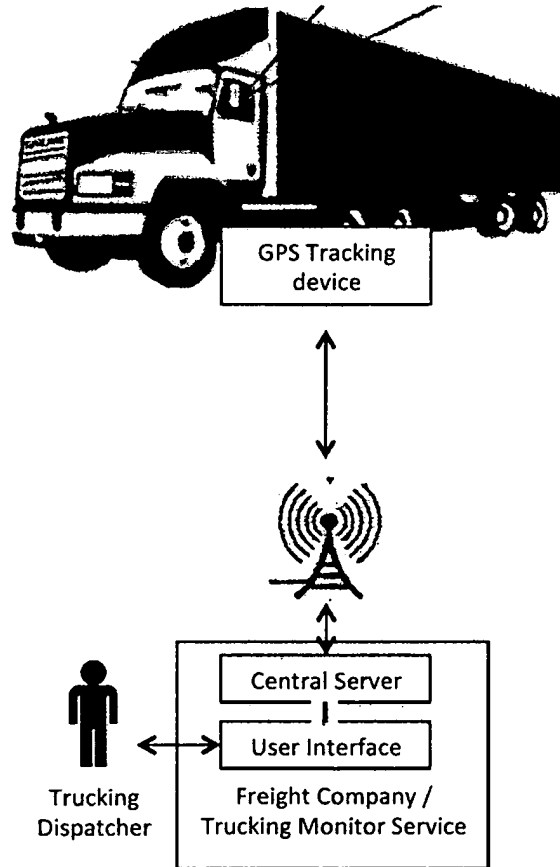

**Conventional System**

**iii. Active vs. Passive location devices on conventional systems (i.e. Discrete location tracking vs. continuous tracking)**

45. In conventional systems different types of GPS vehicle tracking devices exist. Typically they are classified as "passive" and "active." "Passive" devices store GPS location, speed, heading and potentially other vehicle information. Once the vehicle returns to a predetermined point, the device is removed and the data downloaded to a computer for evaluation. Passive systems include auto download type that transfer data via wireless download.

DECLARATION OF IVAN ZATKOVICH IN SUPPORT OF MACROPOINT, LLC'S OPPOSITION  
BRIEF TO FOURKITES, INC.'S MOTION TO DISMISS FIRST AMENDED COMPLAINT

Therefore, Passive devices, or GPS devices operating in passive mode, provide location information at specific checkpoints. In other words, they provide location information at **discrete** points in time rather than **continuously** or in real-time.

46. "Active" devices on the other hand, collect the same information but usually transmit the data in near-real-time via cellular or satellite networks to a computer or data center for evaluation. Some modern vehicle tracking devices combine both active and passive tracking abilities: when a cellular network is available and a tracking device is connected it transmits data to a server; when a network is not available the device stores data in internal memory and will transmit stored data to the server later when the network becomes available again.

47. Therefore, Active devices, or GPS devices operating in active mode, provide location information continuously. In other words, they provide location information at **continuously in real-time** rather than at **discrete** points in time.

**iv. Single channel communication and closed systems**

48. A conventional system also implies that the communication of location information occurs between the vehicles location device (e.g. the GPS device) and the freight company. However, that information must usually be shared with other parties besides the people within the freight company such as the dispatcher. The location of the freight is usually shared with their clients (*i.e.*, the shippers of the freight). That information is typically relayed to their clients either on a periodic basis, or when the clients call for the status of their freight.

49. This means, regardless how the freight company receives the information (as discrete information from passive devices, or continuously from active devices) the client only receives the information at discrete times.



DECLARATION OF IVAN ZATKOVICH IN SUPPORT OF MACROPOINT, LLC'S OPPOSITION  
BRIEF TO FOURKITES, INC.'S MOTION TO DISMISS FIRST AMENDED COMPLAINT

50. This is because the location information is relayed through a single communication channel (i.e. between the vehicle and the freight company). There is no direct method of communication that information directly to other parties. This is also known as a closed system because it is only accessible to limited parties.

51. The following illustrates how a conventional system communicates information from the vehicle to the freight company and then separately relayed to other parties at discrete times.

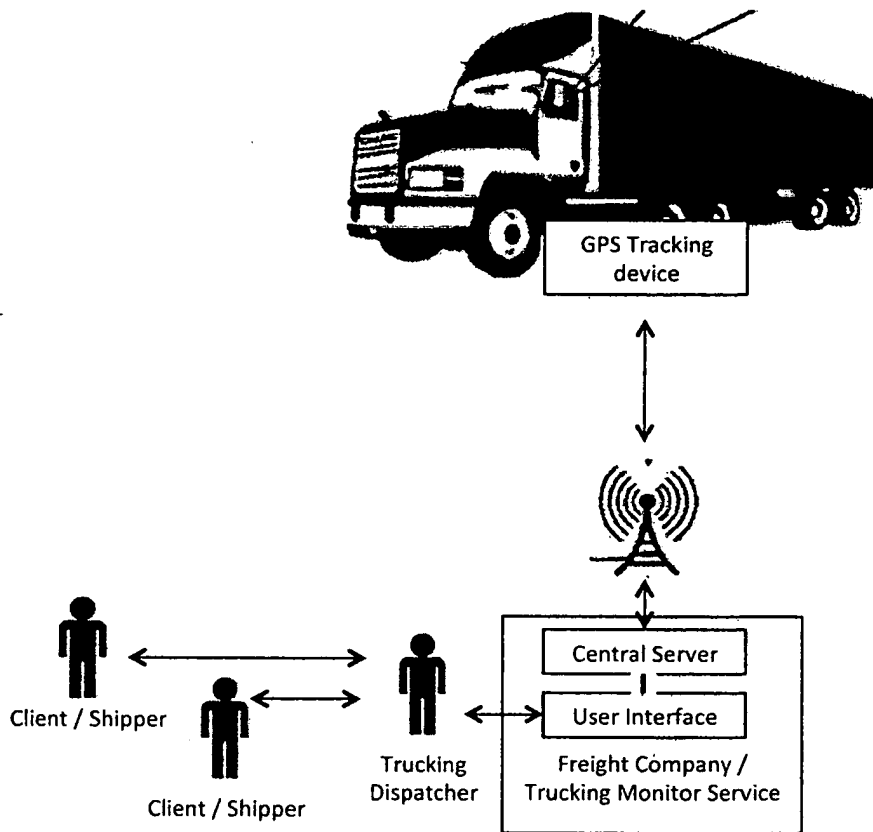

**Conventional System**  
*Single Channel communications*  
*(i.e. closed system)*

DECLARATION OF IVAN ZATKOVICH IN SUPPORT OF MACROPOINT, LLC'S OPPOSITION  
BRIEF TO FOURKITES, INC.'S MOTION TO DISMISS FIRST AMENDED COMPLAINT

v. **The disadvantages of the conventional systems (are also the problems solved by the MacroPoint patents)**

52. The primary disadvantages of conventional fleet tracking systems, at the time of the MacroPoint invention, as indicated above where as follows:

- a. Limited to a single location technology (homogenous location technology).
- b. It is a closed system with only "single channel communication."
- c. It may only provide discrete location information rather than continuous real-time information.

53. These are the specific problems that the MacroPoint invention solves, and are specifically addressed in the MacroPoint specification and claims as described below.

## VII. OVERVIEW OF THE PATENTS IN SUIT

54. The MacroPoint Patents set out to construct a technology environment that is unconventional and significantly different than prior systems in the art and particularly in the field tracking freight and vehicles carrying that freight. The following is a description of prior conventional systems followed by a summary of the MacroPoint invention.

### A. Conventional Systems

#### i. Conventional: Closed Systems

55. The patents-in-suit provide in part:

Conventional systems for monitoring vehicle location have relied on global positioning systems (GPS) to provide the vehicle's location. These systems require a GPS receiver to be installed in each vehicle. Moreover, some of these systems require the installation of additional dedicated equipment in each vehicle.

[ '313 patent 1:56-31; '295 patent 1:34-39; '098 patent 1:56-31;  
'943 patent, 1:31-36; '097 patent, 1:26-31]

DECLARATION OF IVAN ZATKOVICH IN SUPPORT OF MACROPOINT, LLC'S OPPOSITION  
BRIEF TO FOURKITES, INC.'S MOTION TO DISMISS FIRST AMENDED COMPLAINT

56. Conventional systems simply transmit location information between the vehicles in a company's fleet and a dispatch center or monitoring service (i.e. the freight company). The location information was derived from the vehicle itself either by contacting the driver by radio, with a GPS device, or based on which RF tower(s) the truck radio was in communication with. This is a closed system because communication of the location information was restricted to a closed user group, typically between the vehicle and the dispatch center at the freight company.

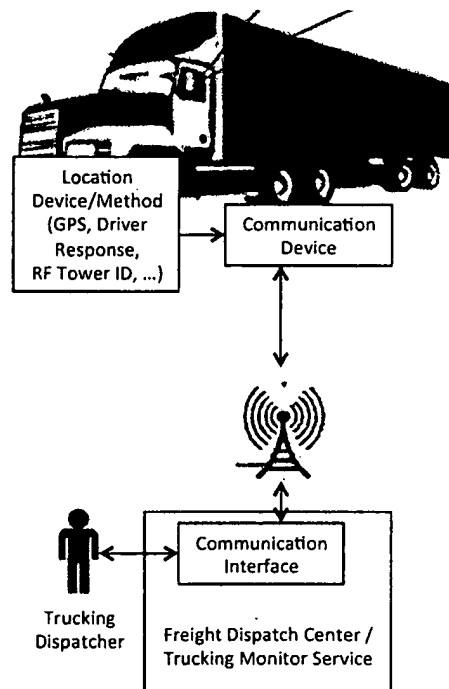

**Conventional  
(closed) System**

57. The client (the shipper who employs the freight company to send their freight or packages) is one of the consumers of the location information. They can have location information relayed from each the dedicated closed system for each fleet where the client / shipper's freight is present through monthly subscription. Such a scheme is prohibitively

DECLARATION OF IVAN ZATKOVICH IN SUPPORT OF MACROPOINT, LLC'S OPPOSITION  
BRIEF TO FOURKITES, INC.'S MOTION TO DISMISS FIRST AMENDED COMPLAINT

expensive for small volume shippers whose relationship with a carrier may be transient and who may deal with multiple fleets.

In addition, at least in part due to limitations of conventional systems for monitoring vehicle location, a common practice in the vehicle location monitoring services industry is to charge a user a standard flat monthly fee for monitoring services. This practice may represent a substantial cost to a user or organization that, for example, may wish to monitor a relatively small number of vehicles or a relatively small number of loads for a relatively short amount of time.

['097 patent 1:32-39; '295 patent 1:40-47; '098 patent 1:32-39;  
'943 patent:37-44; '313 patent 1:32-39]

**ii. Conventional: Single Channel Communication**

58. The typical user interface of conventional systems takes place over a single channel. A user or system requests location information from the conventional system and the conventional system provides a response back to the requestor. In conventional systems the requestor and recipient of the response are the same person (e.g. a truck dispatcher). Location information cannot be directly communicated to other parties. It must be relayed from that single requestor/receiver.

DECLARATION OF IVAN ZATKOVICH IN SUPPORT OF MACROPOINT, LLC'S OPPOSITION  
BRIEF TO FOURKITES, INC.'S MOTION TO DISMISS FIRST AMENDED COMPLAINT

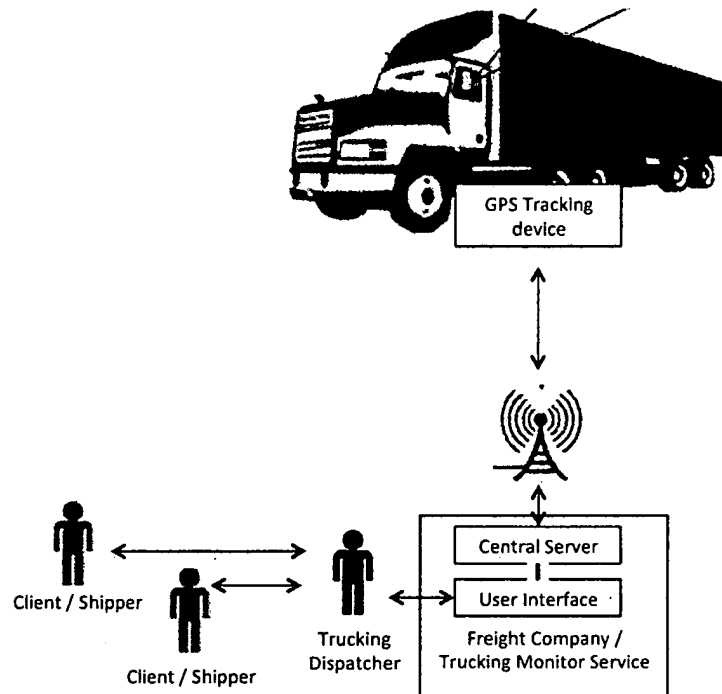

**Conventional System**  
*Single Channel communications*  
*(closed system)*

iii. **Conventional: Single / Homogeneous Location Technology**

59. Standardization is well-known in the art as a method of reducing the complexity and cost of supporting closed systems. Closed systems seek to standardize location methods and communication device technology located on vehicles to simplify the communication interface used at the Freight Dispatch Center / Tracking Monitoring service by installing the same tracking equipment on all trucks in a fleet. For example, in the event of problems with such systems, such as problems obtaining information from a number of trucks, support personnel can have test gear representative of all vehicles, to isolate the location of a fault. Without standardization, there is an added level of complexity of narrowing down the different types of vehicle equipment and

DECLARATION OF IVAN ZATKOVICH IN SUPPORT OF MACROPOINT, LLC'S OPPOSITION  
BRIEF TO FOURKITES, INC.'S MOTION TO DISMISS FIRST AMENDED COMPLAINT

communication devices affected by the problem. In other words, reduced support costs motivates businesses to use homogeneous technology in closed systems.

Alternative methods for monitoring location of vehicles include radiolocation techniques including triangulation or multilateration methods that are capable of locating devices in a network. These methods involve the measurement of radio signals between a device and radio towers in the network. The technology, originally intended by telecommunication companies to approximate the location of a mobile phone in case of emergencies, provides the location of a device in the network.

[ '097 patent 1:43-51; '295 patent 1:51-59; '098 patent 1:43-51;  
'943 patent 1:48-56; '313 patent 1:43-51 ]

**iv. Conventional: Discrete Location Points**

60. In many prior art systems the location is determined discretely and tied to an event such as arrival at a distribution center or a delivery. Even in systems that continuously monitor vehicle location, clients / shippers only receive the 'discrete' locations such as the last distribution center or checkpoint reached.

61. Such discrete methods can only report the last known position, between check-ins not where the vehicle is in real time. For example, a signature is captured on a tablet to confirm delivery and the tablet updates the conventional central system and the vehicle makes its way to the next delivery. Ten minutes later a dispatcher checks the location of the vehicle and there have been no further check-ins. By then the information is old and the dispatcher only knows the last known location of the truck. In other words, conventional centralized systems can only report the location of where vehicles have been, not where they are now.

62. Knowing where the vehicle is between check-ins is of value to clients and shippers to monitor the progress of high value freight and to quickly resolve unforeseen issues such as a breakdown or hijacking.

DECLARATION OF IVAN ZATKOVICH IN SUPPORT OF MACROPOINT, LLC'S OPPOSITION  
BRIEF TO FOURKITES, INC.'S MOTION TO DISMISS FIRST AMENDED COMPLAINT

**B. Invention of the MacroPoint Patents: Unconventional**

**i. Comparison Chart – Conventional vs. Unconventional**

63. The following comparison chart summarizes the differences between prior conventional systems and the MacroPoint invention.

<b>Feature / Function</b>	<b>Prior Conventional Systems</b>	<b>MacroPoint Unconventional System</b>
<b>1. Location Information Gathering</b>	Proprietary / Do it yourself	Independent third party Location Information Provider
<b>2. System Architecture</b>	Closed System – Information Access limited to within the Freight Company	Open System– Information maintained centrally and shared with multiple parties
<b>3. Location Technology</b>	Single / Homogeneous – Uses only one location method	Multiple /Heterogeneous – Can use one or more location methods
<b>4. Location Monitoring</b>	Discrete – Primarily tracks or reports freight arriving/leaving fixed checkpoints	Continuous – Tracks and reports vehicle/freight location continuously.
<b>5. Network Architecture</b>	Point to Point Network – Single channel communication	Hub Network – Multi-channel communication
<b>6. Location Privacy</b>	None – Usually not required in closed systems.	Consent based - Selectable by Vehicle user

64. The claims of the Patents-in-Suit are directed to the limitations of the claimed system 100 as shown in Figure 1 for each of the Patents-in-Suit.

65. As explained more fully below, the claimed methods and systems of the MacroPoint invention are unconventional and innovative for at least the following reasons:

- a. The MacroPoint invention is an Open System;
- b. The MacroPoint invention enables Heterogeneous Locating Technology;
- c. The MacroPoint invention Enables Continuous Monitoring;
- d. The MacroPoint invention is a Hub Network with Multi-Channel communication;

DECLARATION OF IVAN ZATKOVICH IN SUPPORT OF MACROPOINT, LLC'S OPPOSITION  
BRIEF TO FOURKITES, INC.'S MOTION TO DISMISS FIRST AMENDED COMPLAINT

e. The MacroPoint invention Utilizes Consent based privacy.

ii. **The use of a third party Location Information Provider make the MacroPoint invention Unconventional.**

66. The use of a third party Location Information Provider creates an open system where access is provided beyond a trusted closed user group. As shown in Figure 1 the claimed system 100 of the MacroPoint Patents is external to, and distinct from the Location Information Provider 150 as shown in in Figure 1 of each of the MacroPoint patents. Critical to understanding the MacroPoint Invention is that the Location Information Provider is an independent third party, device, or component.



DECLARATION OF IVAN ZATKOVICH IN SUPPORT OF MACROPOINT, LLC'S OPPOSITION  
BRIEF TO FOURKITES, INC.'S MOTION TO DISMISS FIRST AMENDED COMPLAINT

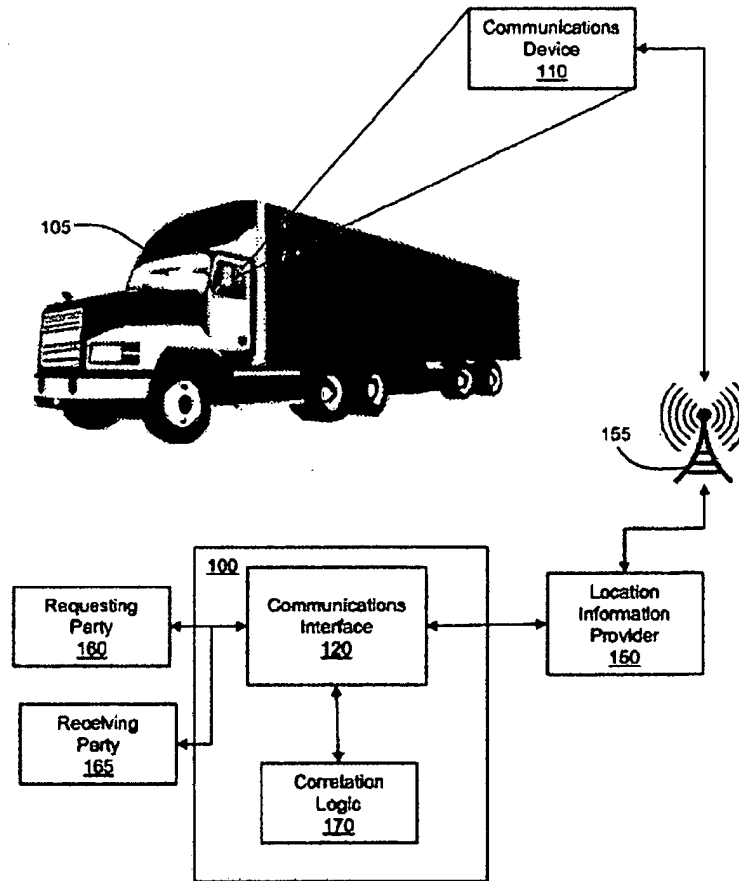

Figure 1

['943 patent, Figure 1; '295 patent, Figure 1; '097 patent, Figure 1; '098 patent, Figure 1; '313 patent, Figure 1]

67. All the MacroPoint patents are consistent in defining a Location Information Provider as corresponding to at least one of,

a wireless service provider providing wireless service to the communications device,

DECLARATION OF IVAN ZATKOVICH IN SUPPORT OF MACROPOINT, LLC'S OPPOSITION  
BRIEF TO FOURKITES, INC.'S MOTION TO DISMISS FIRST AMENDED COMPLAINT

a third party that obtains the location information of the communications device from the wireless service provider providing wireless service to the communications device, and

a party that has access to the location information of the communications device but is other than the wireless service provider or the third party that obtains the location information of the communications device from the wireless service provider.

[‘943 patent, 21:19-29]

The location information provider 150 corresponds to a party or device other than the vehicle 105 and the device 110. The location information provider 150 has access to location of the vehicle 105 or the device 110. In one embodiment, the location information provider 150 is a wireless service provider that provides wireless service in a network 155. In another embodiment, the location information provider 150 is a third party or device that receives the location information of the device 110 from the wireless service provider or from some other party or device. In yet another embodiment, the location information provider 150 is a party other than a wireless service provider or a third party. For example, the party seeking to monitor the location of the vehicle 105, the requesting party 160, may have access to the location information of the device 110. In that case, the requesting party 160 may also be the location information provider 150. In another example, the party operating the system 100 may have access to the location information of the device 110.

[‘943 patent, 4:33-50]

68. The claimed method and system of the MacroPoint patents do not directly obtain location information from the vehicle as do conventional systems. It requests the information from a Location Information Provider external to the system. This differs from conventional systems in which the requested location information comes directly from the vehicle or location device in the vehicle, and is sent directly back to the requestor.

DECLARATION OF IVAN ZATKOVICH IN SUPPORT OF MACROPOINT, LLC'S OPPOSITION  
BRIEF TO FOURKITES, INC.'S MOTION TO DISMISS FIRST AMENDED COMPLAINT

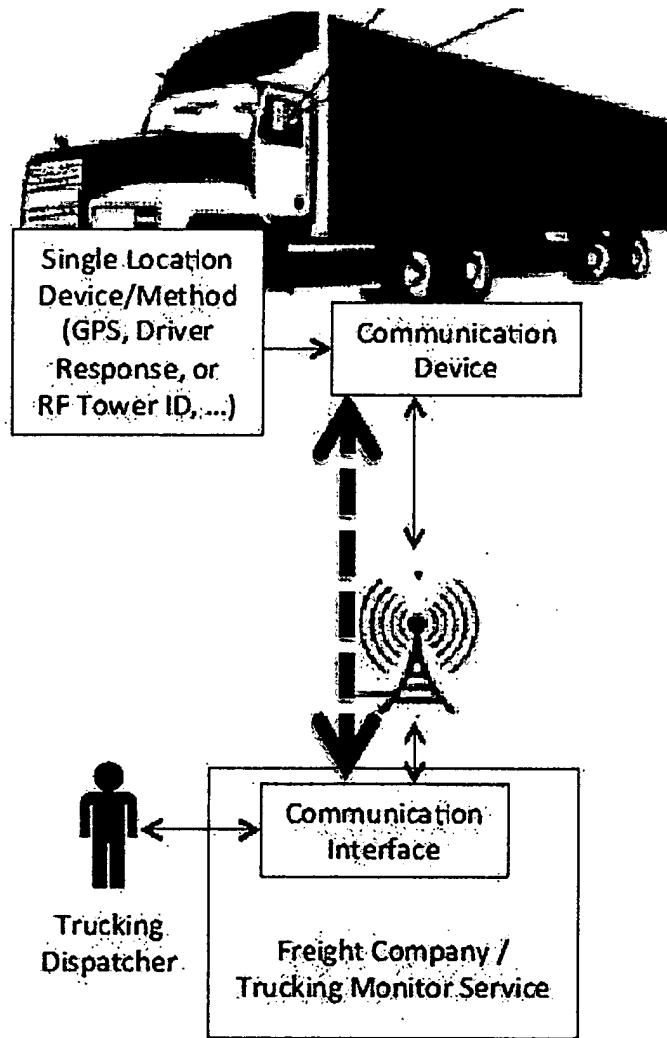

*Conventional System  
(closed system)*

69. The claimed system 100 of the MacroPoint Patents does not directly obtain location information from the vehicle as conventional systems do. It requests it from a Location Information Provider external to the system. This differs markedly from conventional systems (above) where the requested location information comes directly from the vehicle or location device in the vehicle, and is sent directly back to the requestor.

DECLARATION OF IVAN ZATKOVICH IN SUPPORT OF MACROPOINT, LLC'S OPPOSITION  
BRIEF TO FOURKITES, INC.'S MOTION TO DISMISS FIRST AMENDED COMPLAINT

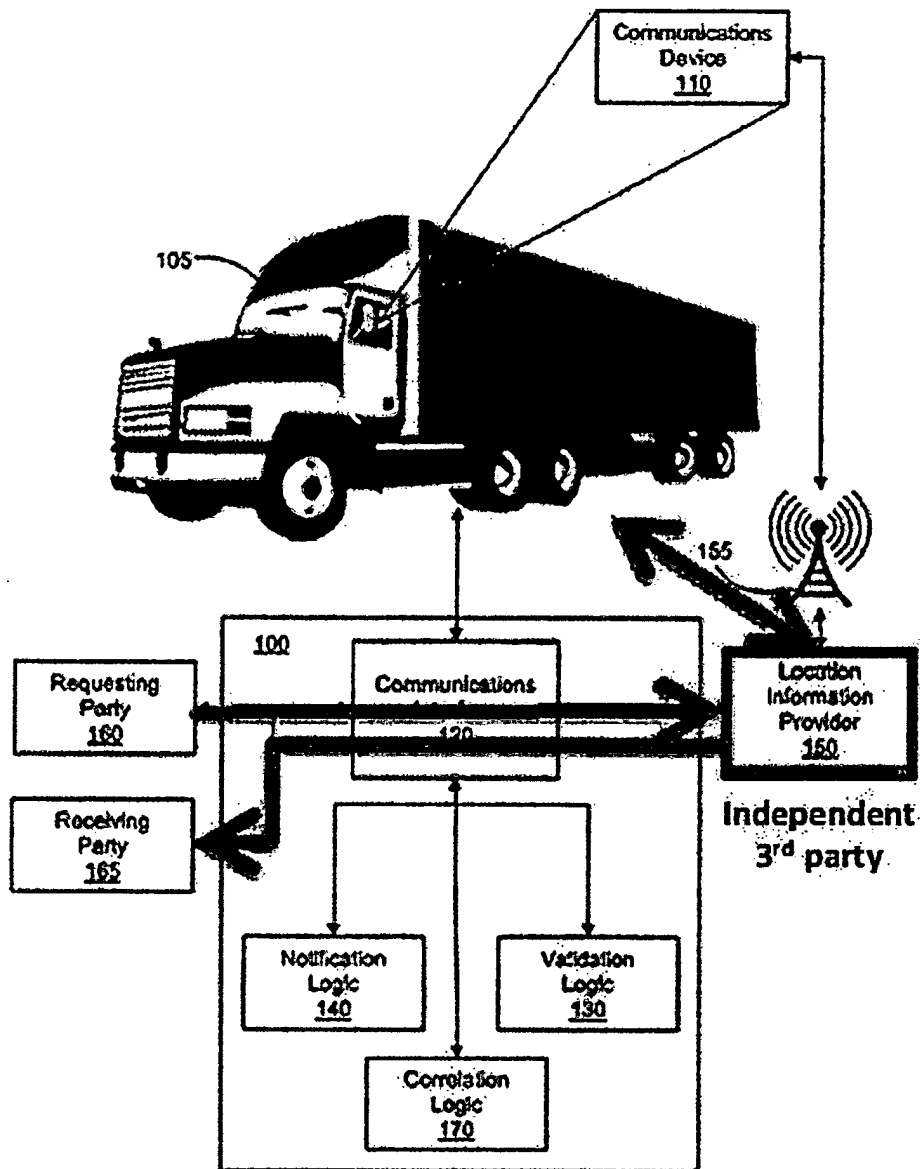

*Unconventional MacroPoint system  
Using Independent third party Location Information Provider  
(open system)*

DECLARATION OF IVAN ZATKOVICH IN SUPPORT OF MACROPOINT, LLC'S OPPOSITION  
BRIEF TO FOURKITES, INC.'S MOTION TO DISMISS FIRST AMENDED COMPLAINT

**iii. The MacroPoint Patents teach an Open System**

70. Changing the system architecture to incorporate an independent third party Location Information Provider and allowing that information to be shared with multiple requestors and recipients makes it an open system. Whereas prior conventional systems simply communicated information between the vehicle and a requestor (the freight company or truck monitoring Service).

71. The function of the Location Information Provider 150 is to accept requests for the location of a communication device 110 from the MacroPoint System 100 (Communications Interface 120) and transmit to the MacroPoint System 100 (Communications Interface 120) data representing the location of communication device 110.

The communications interface 120 transmits to the location information provider 150 data representing one or more requests for location information of the device 110. In response to a request for location information of the device 110, the location information provider 150 transmits and the communications interface 120 receives data representing the location information of the device 110.

['943 patent, 21:19-29; '295 patent, 21:37-47; '097 patent, 21:38-48; '098 patent, 21:32-42; '313 patent, 21:34-44]

72. The Location Information Provider is now the central managing component in the system. All requests for location information are sent to the Location Information Provider and all resulting location information are received from the Location Information Provider, as described in the patent specification.

A computer implemented method for monitoring location of a vehicle includes receiving a first electronic signal including **data representing a request for information regarding the location of the vehicle**, correlating the vehicle to a communications device based at least in part on the communications device being associated with a user who is associated with the vehicle, and

DECLARATION OF IVAN ZATKOVICH IN SUPPORT OF MACROPOINT, LLC'S OPPOSITION  
BRIEF TO FOURKITES, INC.'S MOTION TO DISMISS FIRST AMENDED COMPLAINT

transmitting a second electronic signal to a location information provider corresponding to a party or device other than the communications device. The second electronic signal includes data representing a request for location information of the communications device. The computer implemented method for monitoring location of a vehicle further includes receiving a third electronic signal from the location information provider. The third electronic signal includes data representing the location information of the communications device. The computer implemented method for monitoring location of a vehicle further includes correlating the location information of the communications device with the location of the vehicle based at least in part on the communications device being associated with the user who is associated with the vehicle, and transmitting a fourth electronic signal including data representing the location of the vehicle.

[ '943 patent 2:14-35]

73. Making the third party Location Information Provider the central component that can accept requests from multiple requestors and send location information to multiple receivers makes this an open system. An open system has many advantages but also has disadvantages that creates technical problems to be resolved. The advantages of using a third Party Location information provider include:

- a. The ability to support multiple receivers of location information (e.g. not just the freight company, but the individual shippers of freight)
- b. A large third party Location Information Provider, such as a wireless service provider like AT&T, means you have economy of scale to use multiple forms of location technology, which would then be automatically enhances and new technology becomes available. (e.g. Heterogeneous Location Technology)

DECLARATION OF IVAN ZATKOVICH IN SUPPORT OF MACROPOINT, LLC'S OPPOSITION  
BRIEF TO FOURKITES, INC.'S MOTION TO DISMISS FIRST AMENDED COMPLAINT

- c. Continuous monitoring of the freight location becomes the default, because the technology to gather than information in real-time is available through the third party Location Information Provider. And the ability to report that information in real-time to multiple receivers because the default as well.

74. The challenges presented by a third party Location Information Provider, challenges addressed by the MacroPoint technology, are:

- a. You need a new network architecture to integrate the third party Location Information Provider with the vehicles and the multiple requesting and receiving parties.
- b. You must address the privacy issues inherent with a more open system

75. Incorporating these advantages into the MacroPoint technical solution and overcoming the challenges all are part of the MacroPoint invention.

**iv. The MacroPoint Invention Utilizes Heterogeneous Locating Technology**

76. As the MacroPoint System 100 is independent of the Location Information Provider 150, and does not communicate directly to the communication device 110, the MacroPoint Invention does not rely on any particular positioning technology for obtaining location, or network technology for that matter. The Location Information Provider is not limited in the methods and technology available to obtain the location information it transmits to the claimed system.

However, since the system 100 obtains the location information from the location information provider 150 and not from the device 110, the system 100 can be operated to monitor the location of devices incorporating a GPS satellite receiver as well as devices not incorporating a GPS satellite receiver. Thus, the system 100

DECLARATION OF IVAN ZATKOVICH IN SUPPORT OF MACROPOINT, LLC'S OPPOSITION  
BRIEF TO FOURKITES, INC.'S MOTION TO DISMISS FIRST AMENDED COMPLAINT

does not rely on any particular positioning technology for  
obtaining the location of the vehicle 105.

[ '943 patent, 8:6-13]

77. Consequently, locating technology (GPS, GLONASS, Cell-ID, Triangulation, and communication device networks) is part of, or downstream of the third party Location Information Provider. The specification of the MacroPoint Patents suggests numerous alternate technologies for the source of Location Information Provider data.

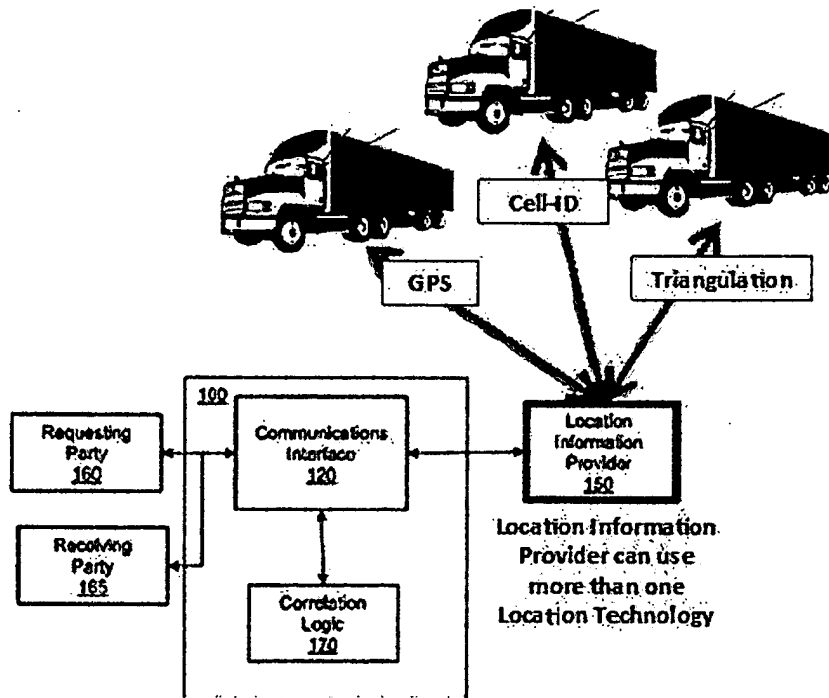

**MacroPoint - Unconventional System**  
*(Multiple) Heterogeneous Location Technology*

As described above, the system 100 receives the location information of the device 110 from a location information provider 150, which is a party or device other than the device 110. The location information provider 150 may be a wireless service provider or a party or device that receives the location information from a wireless service provider. Examples of wireless service providers in the United States include Verizon Wireless, AT&T



DECLARATION OF IVAN ZATKOVICH IN SUPPORT OF MACROPOINT, LLC'S OPPOSITION  
BRIEF TO FOURKITES, INC.'S MOTION TO DISMISS FIRST AMENDED COMPLAINT

Mobility, Sprint Nextel, T-Mobile, etc. These wireless service providers have technologies deployed that allow them to approximate the location of devices in their network. Some of these technologies were developed and deployed in compliance with E911, a government mandate requiring the wireless service providers to provide the approximate location of a mobile device in case of an emergency.

['943 patent, 6:53-67; '295 patent, 6:56-7:3; '097 patent, 6:50-64;  
'098 patent, 6:50-64; '313 patent, 6:50-64]

In one embodiment, the wireless service provider or another party or device originally obtaining or deriving the location information of the device 110 derives the location information of the device 110 at least in part by using a radiolocation technique where the approximated location of the device 110 corresponds to a range of locations corresponding to a transmission range of a single radio tower 155. In an example of this technology, each radio tower is assigned a unique identification number, a Cell-ID. The Cell-ID is received by all mobile devices in the coverage area of the radio tower 155, thus the position of the device 110 in the coverage area of the radio tower 155 is derived from the coordinates of the radio tower 155. Additional techniques, such as measuring signal strength of the device 110 could be used to increase the accuracy of the location information. Accuracy can be further enhanced by including a measurement of Timing Advance (TA) in GSM/GPRS networks or Round Trip Time (RTT) in UMTS networks. TA and RTT use time offset information sent from the radio tower 155 to adjust the communications device's relative transmit time to correctly align the time at which the communications device's signal arrives at the radio tower 155. These measurements can be used to determine the distance from the communications device to the radio tower 155, further improving accuracy.

['943 patent, 7:7-30; '295 patent, 7:10-33; '097 patent, 7:4-28;  
'098 patent, 7:4-28; '313 patent, 7:4-28]

In one embodiment, the wireless service provider or another party or device originally obtaining or deriving the location information of the device 110 derives the location information of the device 110 at least in part using triangulation between multiple radio towers such as tower 155. The location of the device 110 may be determined by using one or a combination of several techniques including the following:

DECLARATION OF IVAN ZATKOVICH IN SUPPORT OF MACROPOINT, LLC'S OPPOSITION  
BRIEF TO FOURKITES, INC.'S MOTION TO DISMISS FIRST AMENDED COMPLAINT

Angle of Arrival (AOA)-This technique requires at least two radio towers and locates the device 110 at the point where the lines along the angles from each tower intersect.

Time Difference of Arrival (TDOA)-This technique also requires at least two radio towers and determines the time difference between the time of arrival of a signal from the device 110 to the first tower 155, to a second tower, and so on.

Advanced Forward Link Trilateration (AFLT)-In this technique the communications device measures signals from nearby towers such as radio tower 155, which are then used to triangulate an approximate location of the device 110.

Enhanced-observed time difference (E-OTD)-This technique takes data received from the nearby towers such as radio tower 155 to measure the difference in time it takes for the data to reach the device 110. The time difference is used to calculate where the device 110 is in relation to the radio towers.

[ '943 patent, 7:30-54; '295 patent, 7:34-57; '097 patent, 7:29-52; '098 patent, 7:29-52; '313 patent, 7:29-52]

78. Notably, neither the claims nor the Specification place a limit on the number of Location Information Providers from which the MacroPoint Invention can obtain location information. Consequently, the MacroPoint Invention can accommodate any number of locating and networking technologies the connected Location Information Providers care to support.

**v. The MacroPoint Invention enables Continuous Monitoring**

79. In the freight tracking industry, as with the MacroPoint invention, it is an objective to provide freight location information on a real-time basis.

"In one example application of the use of location information, carriers, shippers, freight hauling services providers, third-party logistics service providers and courier services providers as well as other logistics and freight service providers (freight hauling) benefit from monitoring the location of vehicles in their fleets or under contract. **Monitoring the location of vehicles helps improve efficiency because it allows for real-time or near real-time decision making** when matching loads with vehicles."

DECLARATION OF IVAN ZATKOVICH IN SUPPORT OF MACROPOINT, LLC'S OPPOSITION  
BRIEF TO FOURKITES, INC.'S MOTION TO DISMISS FIRST AMENDED COMPLAINT

['943 patent, 1:18-26]

80. To this end, the MacroPoint patents teach a method for continuously monitoring of vehicle location information at frequent intervals (e.g. every 15 minutes):

The user interface 800 further displays the Monitoring Term, which corresponds to the total amount of time (e.g., 2 hours) that the location of the associated vehicle will be monitored. The user interface 800 further displays the Monitoring Interval, which **corresponds to how often within the Monitoring Term (e.g., every 15 minutes) the location of the vehicle is updated.**

['943 patent, 14:58-64]

81. Because the polling for location information occurs transparently within the third party Location information provider, the requestor and receiver of location information do not need to know what method is used to collect the location information. It also eliminates any human intervention on vehicle side. Rapid location information updates allows location information to be obtained in real time.

**vi. The MacroPoint Invention creates a Hub based Network for Multi-Channel Communication**

82. As mentioned above, there can be multiple requestors and recipients of location information even for a single vehicle. Therefore the MacroPoint invention must use multi-channel communications. Whereas in conventional systems the requesting party and receiving party are the same, and the location information is only transmitted between the vehicle and the freight company (e.g. single channel communications).

The requesting party 160 corresponds to a party or device interested in monitoring the location of the vehicle 105 or on allowing another party to monitor the location of the vehicle 105. The receiving party 165 corresponds to a party or device who receives the location of the vehicle 105 from the system 100 to monitor the location of the vehicle 105. In an example involving freight hauling services providers or freight carriers, a carrier who

DECLARATION OF IVAN ZATKOVICH IN SUPPORT OF MACROPOINT, LLC'S OPPOSITION  
BRIEF TO FOURKITES, INC.'S MOTION TO DISMISS FIRST AMENDED COMPLAINT

is interested in monitoring the location of its own vehicles, vehicles under contract, or other vehicles requests the ability to monitor the location of the vehicle 105 for its own consumption. In this case, the carrier is both the requesting party 160 and the receiving party 165. In another example, the requesting party 160 may be a driver interested in sharing the location of his/her vehicle 105 with a carrier to allow the carrier to monitor the location of the vehicle 105. In this case, the driver is the requesting party 160 and the carrier is the receiving party 165. In one embodiment, multiple parties or devices may be interested in monitoring the location of the vehicle 105 or on allowing another party to monitor the location of the vehicle 105. In that case, the communications interface 120 is configured to communicate with multiple requesting parties and/or multiple receiving parties.

['943 patent, 4:51-5:5; '295 patent, 4:54-5:8; '097 patent, 4:48-5:2; '098 patent, 4:48-5:2; '313 patent, 4:48-5:2; emphasis added]

83. This feature requires the MacroPoint system to use a Hub based network where the Information Location Provider is the central communication point (the Hub), and all vehicles, requestors, and receivers of information communicate through that Hub. The following shows the basic network configuration of the conventional single-channel communications (a point-to-point Network), versus the MacroPoint Multi-channel communications (a Hub based Network).

DECLARATION OF IVAN ZATKOVICH IN SUPPORT OF MACROPOINT, LLC'S OPPOSITION  
BRIEF TO FOURKITES, INC.'S MOTION TO DISMISS FIRST AMENDED COMPLAINT

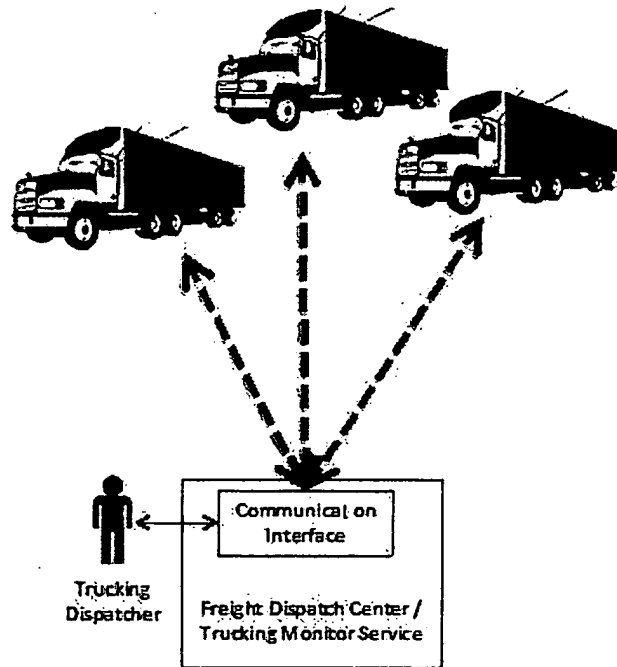

**Conventional Network**  
*Point-to-Point Network*

DECLARATION OF IVAN ZATKOVICH IN SUPPORT OF MACROPOINT, LLC'S OPPOSITION  
BRIEF TO FOURKITES, INC.'S MOTION TO DISMISS FIRST AMENDED COMPLAINT

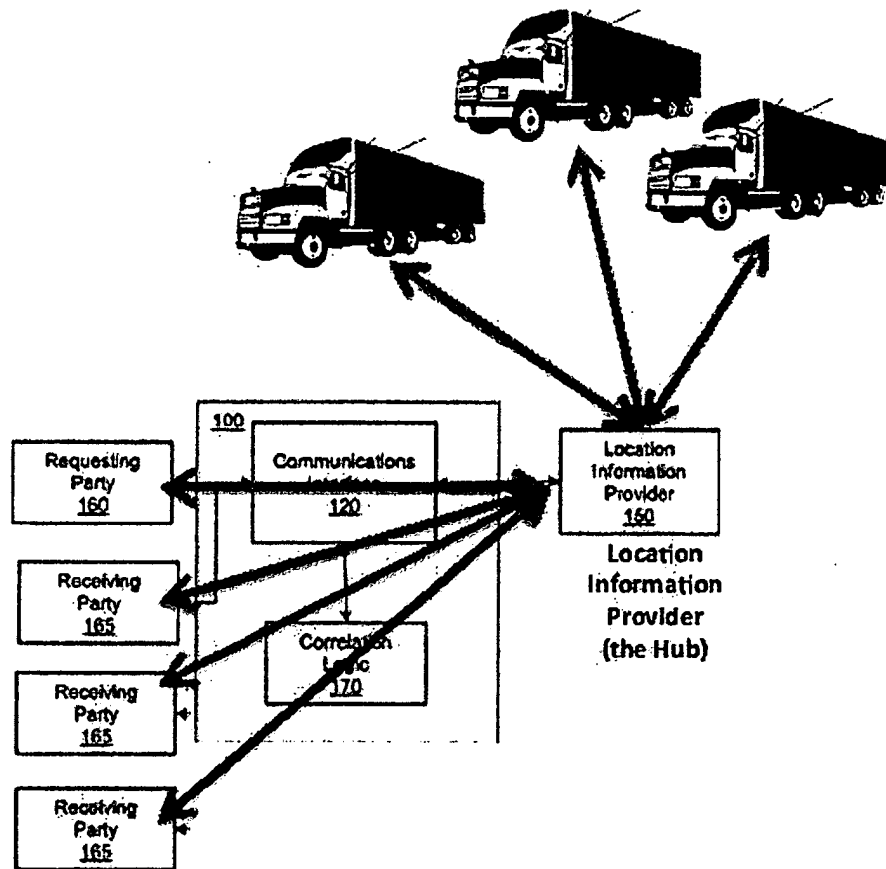

**Unconventional MacroPoint Network**  
*Hub based Network*

**vii. The MacroPoint Invention Incorporates Consent-Based Privacy**

84. Because the MacroPoint invention is an open system the possibility of widespread access to location information raises privacy concerns for the users of communications devices. The CTIA (Cellular Telephone Industries Association) has also weighed in on privacy issues regarding the sharing of location information. The CTIA has provided guidelines on this subject, however with no specific system specifications or design requirements for implementing these guidelines.

DECLARATION OF IVAN ZATKOVICH IN SUPPORT OF MACROPOINT, LLC'S OPPOSITION  
BRIEF TO FOURKITES, INC.'S MOTION TO DISMISS FIRST AMENDED COMPLAINT

The use of all of these location information technologies also raises privacy issues. A user's privacy may be at risk if location information is misused or disclosed without the authorization or knowledge of the user. To address these privacy concerns, various governmental and business organizations have developed rules and guidelines to protect user privacy. For example, the International Association for the Wireless Telecommunications Industry (CTIA) has developed Best Practices and Guidelines for Location-Based Services (the "CTIA Guidelines"), which are hereby incorporated by reference.

The Guidelines provide a framework based on two principles: user notice and consent. Users must receive "meaningful notice about how location information will be used, disclosed and protected so that users can make informed decisions ... and ... have control over their location information." Users must also "consent to the use or disclosure location information" and "have the right to revoke consent ... at any time."

[943 patent, 1:57-2:8]

85. The MacroPoint Invention manages privacy through the use both explicit and implicit (or contextual) Consent. Figure 6 from all the MacroPoint patents illustrates a flow diagram for an exemplary method for receiving "explicit consent" from a user monitoring the location of a vehicle associated with the user.

DECLARATION OF IVAN ZATKOVICH IN SUPPORT OF MACROPOINT, LLC'S OPPOSITION  
 BRIEF TO FOURKITES, INC.'S MOTION TO DISMISS FIRST AMENDED COMPLAINT

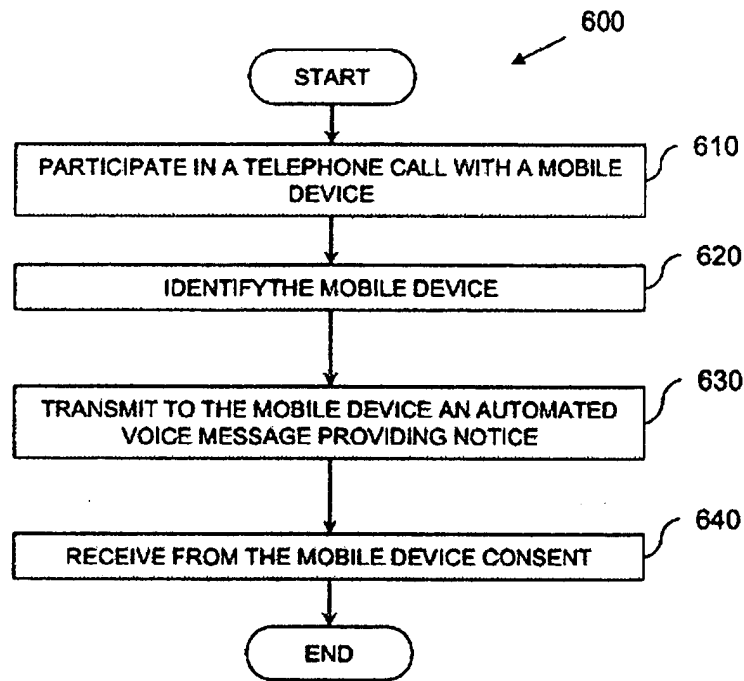

**Figure 6**

86. The user of the communications device in the notification and consent mechanism of the MacroPoint Invention provides consent for the system 100 to monitor the communication device location. In the case where freight location is being monitored, a vehicle can transport different freight from different shippers. A shipper may have freight on any vehicle of any fleet at any given time. Thus the need for a requester 160 or receiver 165 to monitor location information of their freight on a particular vehicle at any given time is transient. Managing the correlation of freight to vehicle to communication device must be performed centrally. And obtaining consent at a system level eliminates the constant distraction a driver might have in responding to constant requests for consent of their location from numerous shippers.



DECLARATION OF IVAN ZATKOVICH IN SUPPORT OF MACROPOINT, LLC'S OPPOSITION  
BRIEF TO FOURKITES, INC.'S MOTION TO DISMISS FIRST AMENDED COMPLAINT

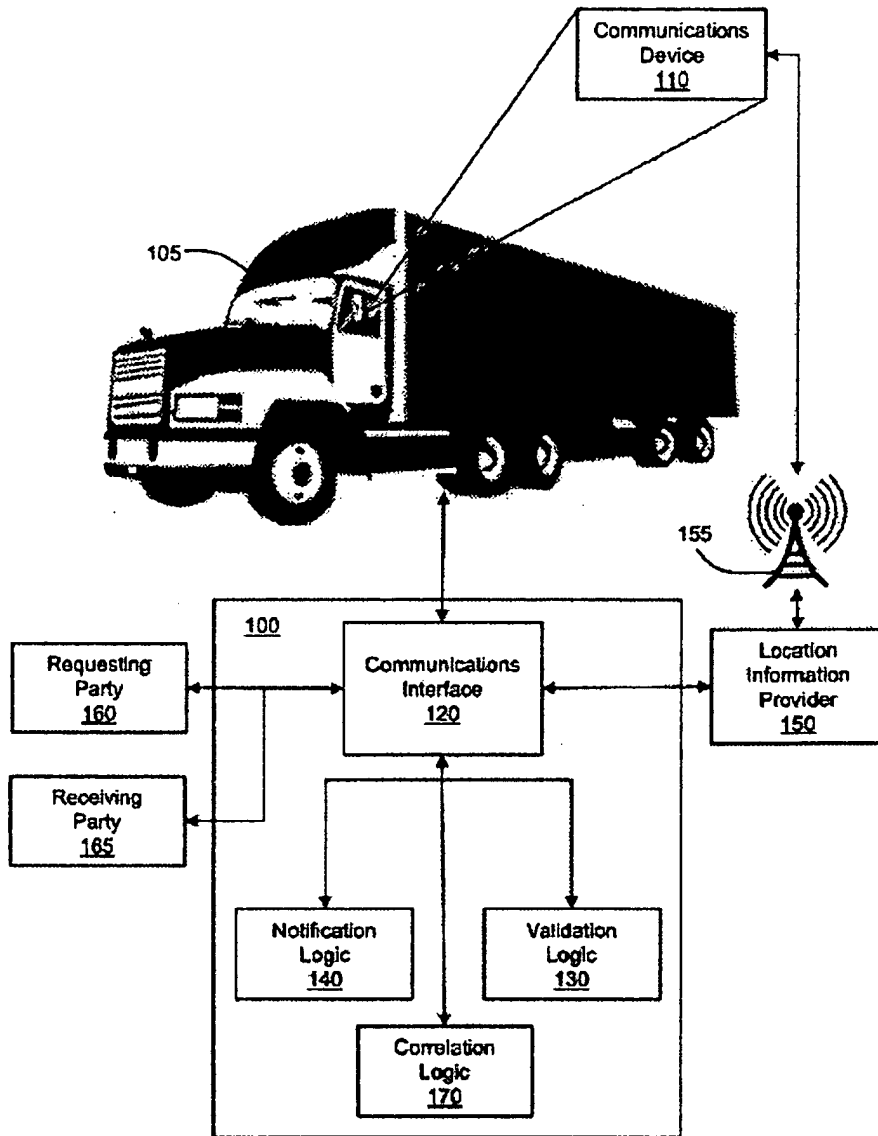

Figure 3

In continued reference to FIG. 3, the system 100 provides user notification and receives user consent to the monitoring the location of the vehicle 105. In this embodiment, the communications interface 120 is further configured for communication with the device 110. In one embodiment, the communication interface 120 is associated with a toll free number such as a 1-800 number. The driver of the vehicle 105 may initiate

DECLARATION OF IVAN ZATKOVICH IN SUPPORT OF MACROPOINT, LLC'S OPPOSITION  
BRIEF TO FOURKITES, INC.'S MOTION TO DISMISS FIRST AMENDED COMPLAINT

a telephone call by dialing the toll free number. In another embodiment, the communications interface is associated with a number other than a toll free number. In yet another embodiment, the communications interface 120 is configured to initiate the telephone call.

['943 patent, 8:14-25]

87. To increase the automation of receiving consent and relieve the driver from constant interruptions, the MacroPoint invention defines several configurations for "implicit" or automated consent that still gives a level of control to the vehicle user (driver) regarding the location of the vehicle. In one method the driver sets the window (a date and time) when he will allow his location to be known to requestors of location information.

In one embodiment, the user is given the option to temporarily revoke consent to the disclosure of location information. For example, a driver may wish to make available his location to a carrier during certain hours during the work week, but may not want the carrier to be able to obtain the driver's location during the weekend. The driver may operate the device 110 to **indicate a date and time when the driver wishes for the monitoring of the location of the vehicle 105 to end or resume.**

['943 patent, 9:60-10:1]

88. This consent automation is also taught in the claim limitations:

transmitting to the communications device a second signal including data that prompts an automated message to be communicated to a user of the communications device, the **automated message representing a notice** communicating to the user of the communications device that the location information of the communication device will be obtained;

receiving from the communications device a third signal including **data indicative of consent** from the user to the obtaining of the location information of the communications device;

['931 patent, Claim 1]

DECLARATION OF IVAN ZATKOVICH IN SUPPORT OF MACROPOINT, LLC'S OPPOSITION  
BRIEF TO FOURKITES, INC.'S MOTION TO DISMISS FIRST AMENDED COMPLAINT

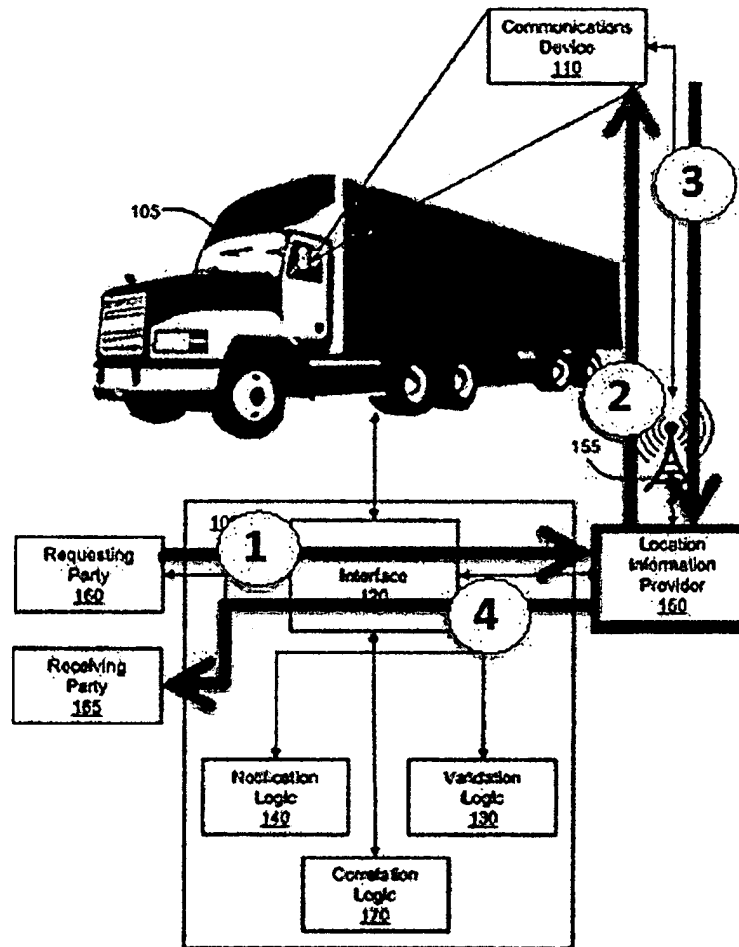

**MacroPoint - Unconventional System**

*Continuous information – automated notification & consent*

89. Although the claims teach a slightly more lengthy protocol for requesting location information, this briefly shows the primary steps:

- a. Step 1: The Requestor requests location information.
- b. Step 2: Automatic Notification of Consent is sent to communication device.
- c. Step 3: The Consent response is returned (either explicitly or automatically/implicitly) from the communication device. The Implicit method

DECLARATION OF IVAN ZATKOVICH IN SUPPORT OF MACROPOINT, LLC'S OPPOSITION  
BRIEF TO FOURKITES, INC.'S MOTION TO DISMISS FIRST AMENDED COMPLAINT

maintains a continuous automatic flow of location information without having  
to interrupt the vehicle user.

- d. Step 4: The Receiver is sent location information.

**C. Technical Problems to Be Solved with Technical Solutions**

90. The MacroPoint invention creates an unconventional technical environment with an independent third party Location Information Provider with an Open System Architecture for providing access the Multiple Requestors and Receivers of location information. These technical problems require specific technical solutions that are described in the MacroPoint patents:

- a. Using a third party Location Information Provider to create an "open system" for access by multiple parties.

DECLARATION OF IVAN ZATKOVICH IN SUPPORT OF MACROPOINT, LLC'S OPPOSITION  
BRIEF TO FOURKITES, INC.'S MOTION TO DISMISS FIRST AMENDED COMPLAINT

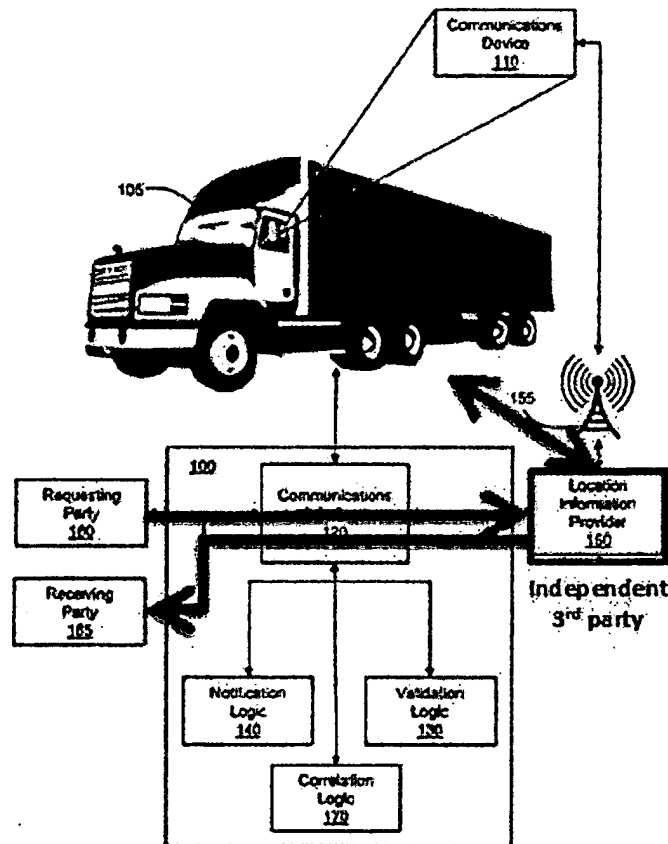

*Independent third party Location Information Provider  
Open System*

- b. Creating a Hub based Network to provide a Multi-channel communication for the multiple requestors and receivers.

DECLARATION OF IVAN ZATKOVICH IN SUPPORT OF MACROPOINT, LLC'S OPPOSITION  
BRIEF TO FOURKITES, INC.'S MOTION TO DISMISS FIRST AMENDED COMPLAINT

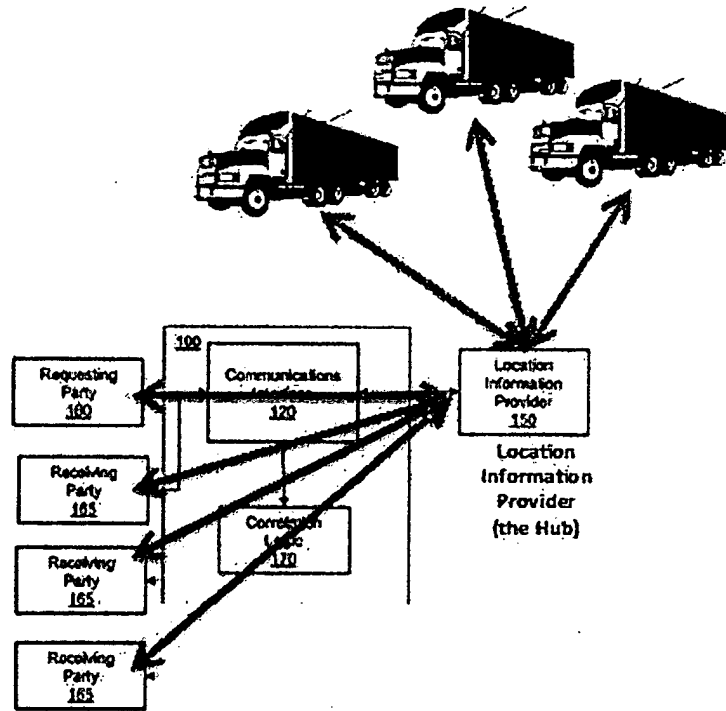

*Hub based Network, multi-channel communications*

- c. Using the third party Location Information Provider to enable Heterogeneous location technology that enables multiple location methods (e.g. GPS, GLONASS, RF Triangulation, etc.).

DECLARATION OF IVAN ZATKOVICH IN SUPPORT OF MACROPOINT, LLC'S OPPOSITION  
BRIEF TO FOURKITES, INC.'S MOTION TO DISMISS FIRST AMENDED COMPLAINT

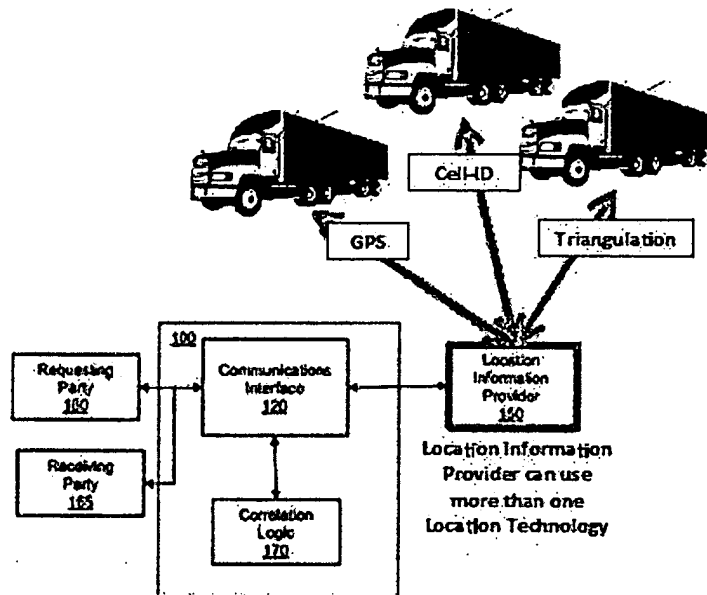

*(Multiple) Heterogeneous Location Technology*

- d. Providing Automated response allows for consent and continuous capture of location information for real-time monitoring.

DECLARATION OF IVAN ZATKOVICH IN SUPPORT OF MACROPOINT, LLC'S OPPOSITION  
BRIEF TO FOURKITES, INC.'S MOTION TO DISMISS FIRST AMENDED COMPLAINT

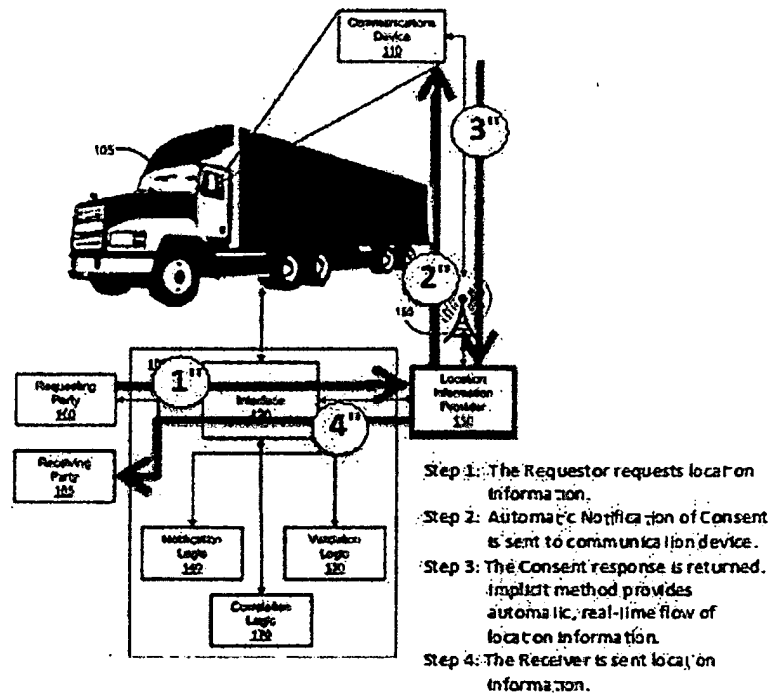

*Continuous information – automated notification & consent*

91. These are elements that are present in all independent claims of the MacroPoint patents. These elements, among others, represent activities that are significantly more than an abstract idea.

**VIII. THE CLAIMS ARE DIRECTED TO PATENT-ELIGIBLE SUBJECT MATTER**

**A. USPTO Two-Part Test**

92. I understand that the U.S. Patent Office has implemented a two-part test by which USPTO patent examiners are to determine patent-eligible subject matter in light of the Supreme Court's decisions in *Alice* and *Mayo* and other recent federal court rulings. The following diagram is an extract of the USPTO 2014 Interim Eligibility Guidance Quick Reference Sheet



DECLARATION OF IVAN ZATKOVICH IN SUPPORT OF MACROPOINT, LLC'S OPPOSITION  
BRIEF TO FOURKITES, INC.'S MOTION TO DISMISS FIRST AMENDED COMPLAINT

that is currently being used by patent examiners to evaluate whether a claim is drawn to patent-eligible subject matter.

93. In "Part 1 of the *Mayo* test" (labeled as step 2A in diagram) it is the objective of the examiner to determine if the claimed invention is directed to e.g. an abstract idea. In "Part 2 of the *Mayo* test" (labeled as step 2B in diagram), if the claims are directed to an abstract idea, the examiner must determine if the claims recite additional elements that amount to significantly more than the judicial exception [of the abstract idea].

DECLARATION OF IVAN ZATKOVICH IN SUPPORT OF MACROPOINT, LLC'S OPPOSITION  
BRIEF TO FOURKITES, INC.'S MOTION TO DISMISS FIRST AMENDED COMPLAINT

**SUBJECT MATTER ELIGIBILITY TEST FOR  
PRODUCTS AND PROCESSES**

*PRIOR TO EVALUATING A CLAIM FOR PATENTABILITY, ESTABLISH THE  
BROADEST REASONABLE INTERPRETATION OF THE CLAIM.  
ANALYZE THE CLAIM AS A WHOLE WHEN EVALUATING FOR PATENTABILITY.*

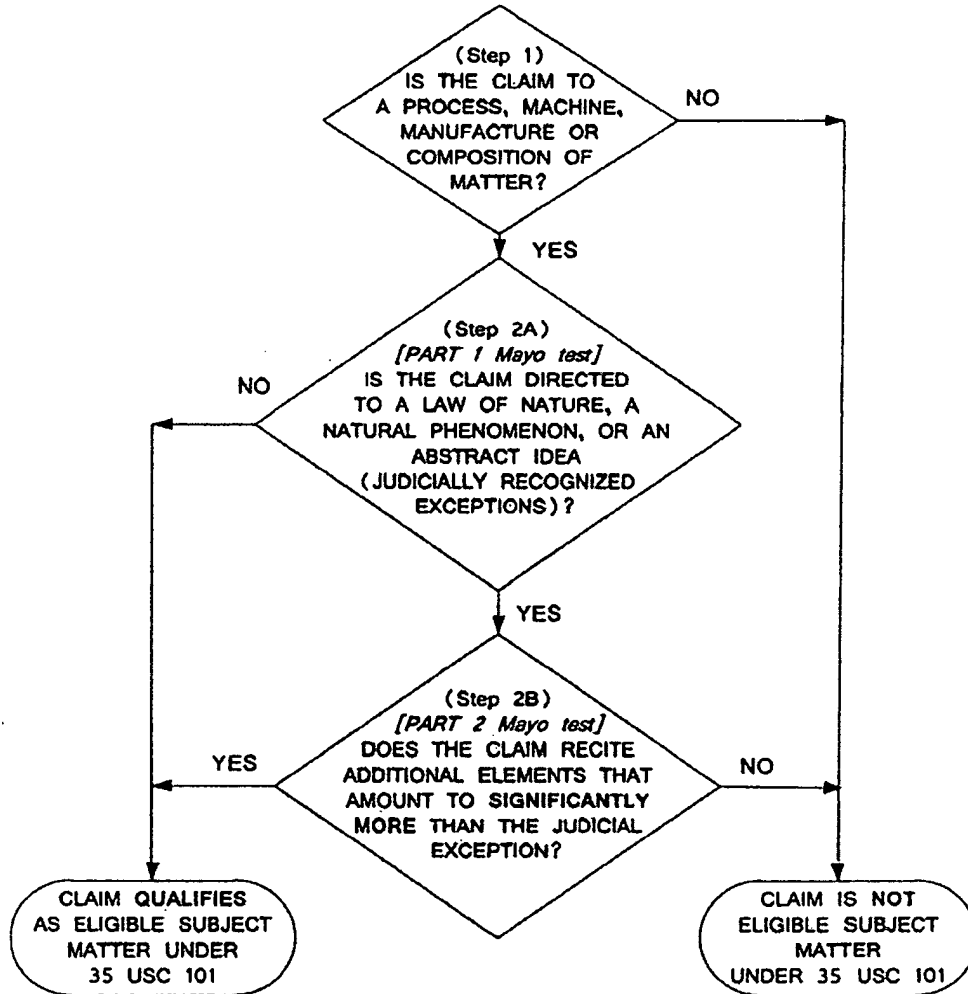

94. In this section, I have applied this two part test as part of my technical analysis of the MacroPoint patents.

DECLARATION OF IVAN ZATKOVICH IN SUPPORT OF MACROPOINT, LLC'S OPPOSITION  
BRIEF TO FOURKITES, INC.'S MOTION TO DISMISS FIRST AMENDED COMPLAINT

**B. Part 1 of the *Mayo* test: The Claims of the MacroPoint Patents are Directed to A Novel and Patent Eligible Open System Architecture and not simply to the "Abstract Idea of Freight Tracking."**

95. One of skill in the art would understand that method and system claims of the MacroPoint patents are directed to an open system architecture, and use of that open system architecture, that is specifically designed to enable a third party Location Information Provider to act as a central source of location information. The open system architecture can: facilitate requesting and receiving consent to transfer location information of a communication device; correlating the communication device with a vehicle or freight carried by a vehicle; and communicating with multiple parties that request and receive location information of the vehicle or freight carried by the vehicle.

96. A person of skill in the art would understand that the claims of the MacroPoint patents require elements that are concrete and tangible, and specifically define an open system architecture required to integrate a third party Location Information Provider with the multiple requestors/receivers.

97. In the open system, the location information is generated and/or maintained as central network-based services using a third party Location Information Provider. This contrasts with the conventional freight tracking systems, which are closed systems, that communicated directly between the vehicle and the fleet tracking system (the trucking dispatch center and/or the trucking monitoring service). An open system that centralizes the location information allows multiple parties (multiple dispatchers, clients, shippers) to send location requests and receive location information virtually simultaneously. Since the location information is provided to multiple parties, the MacroPoint invention needs the ability to protect the privacy of the user or

DECLARATION OF IVAN ZATKOVICH IN SUPPORT OF MACROPOINT, LLC'S OPPOSITION  
BRIEF TO FOURKITES, INC.'S MOTION TO DISMISS FIRST AMENDED COMPLAINT

owner of the communication device. The MacroPoint invention provides for an indication of such consent before transferring or providing location information.

**i. All independent claims contain concrete and tangible elements**

98. Each independent claim of the MacroPoint patents recites concrete and tangible elements. The MacroPoint patents include both method claims and system claims for obtaining or monitoring the location of a vehicle or freight carried by a vehicle.

The '943 patent

99. Independent claim 1 is directed to a computer implemented method for indicating location of freight carried by a vehicle. The method includes the following:

a. A communications device to send and receive information:

transmitting to **the communications device** a second signal including data that prompts an automated message to be communicated to a user of the communications device, the automated message representing a notice communicating to the user of the communications device that the location information of the communication device will be obtained;

receiving from the **communications device** a third signal including data indicative of consent from the user to the obtaining of the location information of the communications device;

b. A Location Information Provider is a party or device other than the

communication device and can be location services provided by a third party, a wireless service provider or other third party (such as AT&T, Lync, Tata Indicom, and similar vendors)

DECLARATION OF IVAN ZATKOVICH IN SUPPORT OF MACROPOINT, LLC'S OPPOSITION  
BRIEF TO FOURKITES, INC.'S MOTION TO DISMISS FIRST AMENDED COMPLAINT

transmitting a fourth signal to a **location information provider**, the fourth signal including data representing a request for location information of the communications device, wherein the location information provider corresponds to a party or device other than the communications device and the location information provider corresponds to at least one of:

a **wireless service provider** providing wireless service to the communications device,

a **third party that obtains the location information** of the communications device from the wireless service provider providing wireless service to the communications device, and

a **party that has access to the location information** of the communications device but is other than the wireless service provider or the third party that obtains the location information of the communications device from the wireless service provider.

100. Independent claim 8 is directed to a system for obtaining location of freight carried by a vehicle. The system includes the following:

a. A communications device to send and receive information:

a notification logic configured to generate a fifth electronic signal including data that causes the **communications device** to generate a notice indicating to a user of the communications device that the location information of the communications device will be disclosed, wherein the communications interface is further configured to: transmit the fifth electronic signal to the **communications device**, and receive from the **communications device** a sixth signal including data indicative of consent from the user to the obtaining of the location information of the communications device.

b. A Location Information Provider is a party or device other than the

communication device and can be location services provided by a third party, a wireless service provider or other third party (such as AT&T, Lync, Tata Indicom, and similar vendors)

a third electronic signal including data representing the location information of the communications device, wherein the third electronic signal is received

DECLARATION OF IVAN ZATKOVICH IN SUPPORT OF MACROPOINT, LLC'S OPPOSITION  
BRIEF TO FOURKITES, INC.'S MOTION TO DISMISS FIRST AMENDED COMPLAINT

from a **location information provider** corresponding to a party or device other than the communications device and corresponding to one or more of:

a **wireless service provider** providing wireless service to the communications device,

a **third party obtaining the location information** from the wireless service provider providing wireless service to the communications device, and

a **party that has access to the location information**, but is other than the wireless service provider or the third party that obtains the location information from the wireless service provider;

101. Independent claims 1 and 8 of the '295 patent; independent claims of the 1, 8, 15, and 22 of the '097 patent; independent claims 1 and 11 of the '098 patent; and independent claims 1, 9, and 15 of the '313 patent include similar concrete and tangible elements.

ii. **System independent claims contain additional concrete and tangible elements**

102. Although the MacroPoint method claims share the same innovative concepts and the system claims, the system and machine claims identify additional system components necessary to implement the claimed invention.

a. A Communication Interface is a device that sends specific data signals in a specific sequence between the third party Location information provider, the communications device, and the requestor and receivers.

a **communications interface** configured to communicate electronic signals including:

[ '943 patent, Claim 8 ]

b. All system independent claims identify at least one type of logic which the MacroPoint patents deem as implemented as Hardware, Firmware, or Software.

All three types of logic identified in the MacroPoint claims (correlation,

DECLARATION OF IVAN ZATKOVICH IN SUPPORT OF MACROPOINT, LLC'S OPPOSITION  
BRIEF TO FOURKITES, INC.'S MOTION TO DISMISS FIRST AMENDED COMPLAINT

notification, validation) require an operation to occur with a physical  
communications device.

Thus, the **validation logic** 1030, whether implemented in computer 1000 as hardware, firmware, software, or a combination thereof may provide means for identifying the communications device at least in part by obtaining an identifier associated with the communications device.

[ '943 patent, 16:57:63]

a **correlation logic** configured to correlate the location information of the communications device to the location of the freight;

a **validation logic** configured to identify the communications device at least in part by obtaining an identifier associated with the communications device; and

a **notification logic** configured to generate a fifth electronic signal including data that causes the communications device to generate a notice indicating to a user of the communications device that the location information of the communications device will be disclosed,

[ '943 patent, Claim 8]

iii. **All independent claims have dependent claims that contain additional concrete and tangible elements**

103. Each independent claim of the MacroPoint patents has at least one dependent claim that recites additional concrete and tangible elements. For example, in the '943 Patent, dependent claims recited the following elements:

- a. One or more requesting parties such as; the freight service itself, a location information provider, or a freight service client or shipper:

7. The method of claim 1, wherein the **requesting party** corresponds to one of:

a **freight service provider** wherein the location of the freight is transmitted to the freight service provider,

a **party that provides location information services** to the freight service provider, and

DECLARATION OF IVAN ZATKOVICH IN SUPPORT OF MACROPOINT, LLC'S OPPOSITION  
BRIEF TO FOURKITES, INC.'S MOTION TO DISMISS FIRST AMENDED COMPLAINT

the **driver of the vehicle** requesting that the location of the freight be transmitted to a freight service provider for the freight service provider to have access to location of the freight carried by the vehicle.

['943 patent, Claim 7]

- b. One or more receiving parties that receive location information such as; the freight service itself, a location information provider, or a freight service client or shipper:

11. The system of claim 8, wherein the communications interface is configured to **transmit the fourth electronic signal to one or more of:**

a **freight service provider** wherein the location of the freight carried by the vehicle is transmitted to the freight service provider,

a **party that provides location information services** to the freight service provider, and

the driver of the vehicle requesting that the location of the vehicle be transmitted to a **freight service provider** for the freight service provider to have access to location information of freight carried by the vehicle.

['943 patent, Claim 11]

- c. One or more location devices or methods such as; a GPS receiver, radio triangulation, Radio or Cell tower location:

10. The system of claim 8, wherein the location information of the communications device is originally obtained through **techniques including at least one:**

**triangulation** between radio towers,

obtaining a range of locations corresponding to a **transmission range of a single radio tower**,

advance forward link trilateration (AFLT),

observed time difference (OTD), and



DECLARATION OF IVAN ZATKOVICH IN SUPPORT OF MACROPOINT, LLC'S OPPOSITION  
BRIEF TO FOURKITES, INC.'S MOTION TO DISMISS FIRST AMENDED COMPLAINT

Cell-ID (CID).

['943 patent, Claim 10]

3. The method of claim 1, wherein the location information of the communications device is originally obtained using a method including a technique **utilizing a global position system (GPS) satellite receiver** that forms part of the communications device.

['098 patent, Claim 3]

104. Dependent claims of the '295 patent, the '097 patent, the '098 patent, and '313 patent all include similar concrete and tangible elements.

**iv. The claims are not directed to an abstract idea.**

105. The claim elements of the MacroPoint patents define a specific system and network configuration because they specify the system's physical components and entities (freight, vehicles, a communications device in each vehicle, a third party Location Information Provider, specific location requesters, specific location receivers, and specific location technology and devices). In other words, the claims specify the elements of an open system architecture designed to enable a third party Location Information Provider to act as a central source of location information, requesting and receiving consent to transfer the location information of the communication device, and communicate between multiple parties that request and receive location information of the vehicle or freight carried by a vehicle.

**C. Part 2 of the *Mayo* test: The Claims of the MacroPoint Patents also amount to significantly more than "An Abstract Idea of Freight Tracking" with the addition of an Unconventional Open System Architecture.**

106. The claims of the MacroPoint patents are directed to an Open System Architecture, not the "abstract idea of tracking freight." The claimed Freight Monitoring System

DECLARATION OF IVAN ZATKOVICH IN SUPPORT OF MACROPOINT, LLC'S OPPOSITION  
BRIEF TO FOURKITES, INC.'S MOTION TO DISMISS FIRST AMENDED COMPLAINT

represented a dramatic change in the system architecture of the freight tracking industry. It introduced a paradigm shift in the way Freight Services performed their freight tracking.

107. The MacroPoint independent claims recite significantly more than an abstract idea, including:

- a. Using a third party Location Information Provider to create an "open system" for access by multiple parties.
- b. Using a Hub based Network provides a Multi-channel communication.
- c. A third party Location Information Provider allows Heterogeneous location technology.
- d. Automated response provides consent and continuous capture of location information for real-time monitoring.
- i. **Using a third party Location Information Provider creates an "open system" for access by multiple parties.**

108. One distinguishing feature of the MacroPoint invention from previous freight tracking systems is the placement of a third Party Location Information Provider as a central arbiter of all incoming location requests and outgoing location transmissions. This is contrasted with conventional systems where the requested location information directly from the vehicle or location device in the vehicle. And that location information was send directly back to the requestor.

A computer implemented method for monitoring location of a vehicle includes receiving a first electronic signal including **data representing a request for information regarding the location of the vehicle**, correlating the vehicle to a communications device based at least in part on the communications device being associated with a user who is associated with the vehicle, and **transmitting a second electronic signal to a location**

DECLARATION OF IVAN ZATKOVICH IN SUPPORT OF MACROPOINT, LLC'S OPPOSITION  
BRIEF TO FOURKITES, INC.'S MOTION TO DISMISS FIRST AMENDED COMPLAINT

**information provider corresponding to a party or device other than the communications device.** The second electronic signal includes data representing a request for location information of the communications device. The computer implemented method for monitoring location of a vehicle further includes **receiving a third electronic signal from the location information provider.** The third electronic signal includes data **representing the location information of the communications device.** The computer implemented method for monitoring location of a vehicle further includes correlating the location information of the communications device with the location of the vehicle based at least in part on the communications device being associated with the user who is associated with the vehicle, and transmitting a fourth electronic signal including data representing the location of the vehicle.

[ '943 patent, 2:14-35]

109. The following diagram illustrates the unconventional MacroPoint system. In the unconventional MacroPoint system all requests go to a third party. This allows the location information to be requested and received by many different parties.

DECLARATION OF IVAN ZATKOVICH IN SUPPORT OF MACROPOINT, LLC'S OPPOSITION  
BRIEF TO FOURKITES, INC.'S MOTION TO DISMISS FIRST AMENDED COMPLAINT

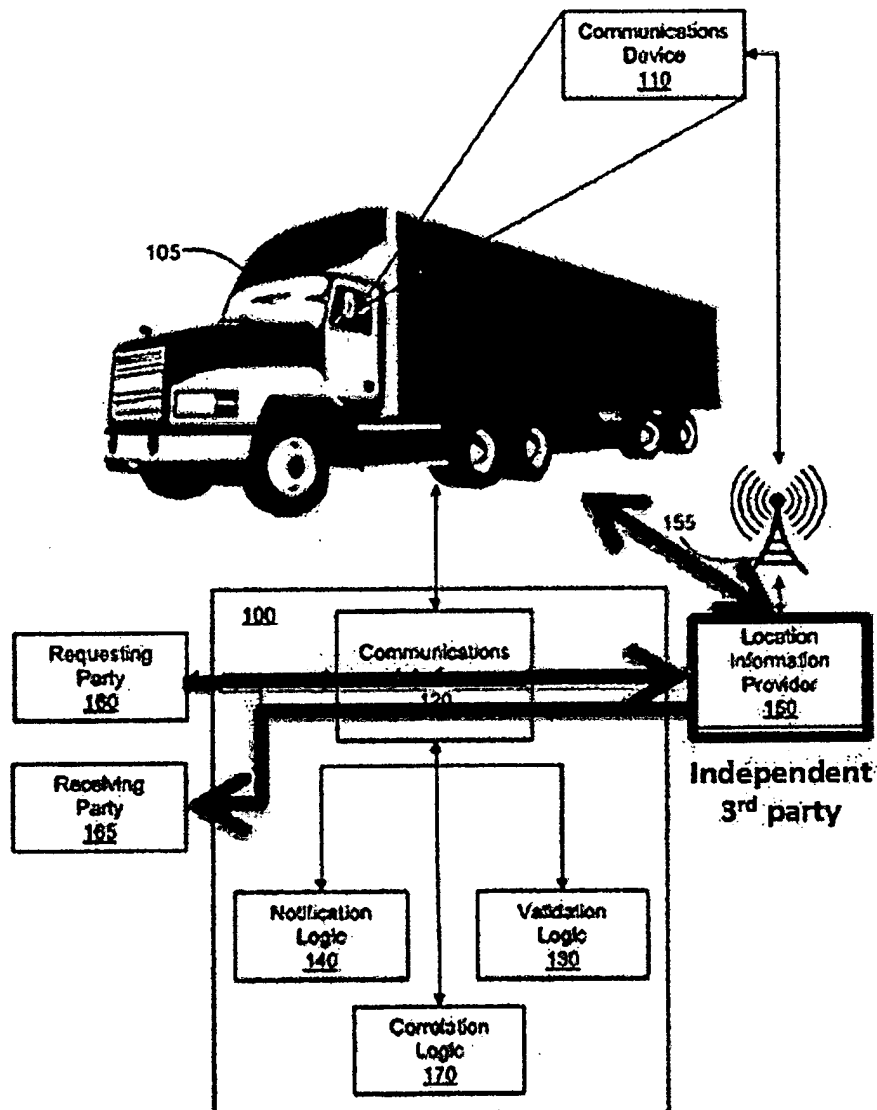

**Unconventional MacroPoint system**  
*Using Independent third party Location Information Provider  
(open system)*

Central management of requests

110. By placing an intermediary (the Information Location Provider) between the location requestor and the vehicle an open system is created. In an open system the location

DECLARATION OF IVAN ZATKOVICH IN SUPPORT OF MACROPOINT, LLC'S OPPOSITION  
BRIEF TO FOURKITES, INC.'S MOTION TO DISMISS FIRST AMENDED COMPLAINT

information can be shared among multiple parties at the same time. This is unconventional since previous freight tracking systems did not normally share the real-time location of a vehicle with parties other than the freight company itself.

Central arbitration of Consent

111. Sharing location information with multiple parties makes it desirable/necessary to introduce privacy controls. In other words, in a conventional system, location information is only transmitted between two parties or components (e.g. between the vehicle and the freight service). So the privacy is implied to be between the trucker (employee) and the freight service (employer). This is not true of an open system.

112. In an open system the vehicle's location can now be received by the freight service, by clients, or presumably by any shipper that has freight on that vehicle. Therefore, the system must notify and/or determine the consent of the user or owner of the communication device before location information of the communication device is transferred or otherwise used.

**ii. Using a Hub based Network provides a Multi-channel communication**

113. Introducing a third party Location Information Provider also changes how the communication network for the freight tracking system must be configured. The conventional freight tracking system will have Point-to-Point communications between the Vehicles and the freight company (or trucking monitor). In other words, communication is directly between the vehicles and the freight company.

DECLARATION OF IVAN ZATKOVICH IN SUPPORT OF MACROPOINT, LLC'S OPPOSITION  
BRIEF TO FOURKITES, INC.'S MOTION TO DISMISS FIRST AMENDED COMPLAINT

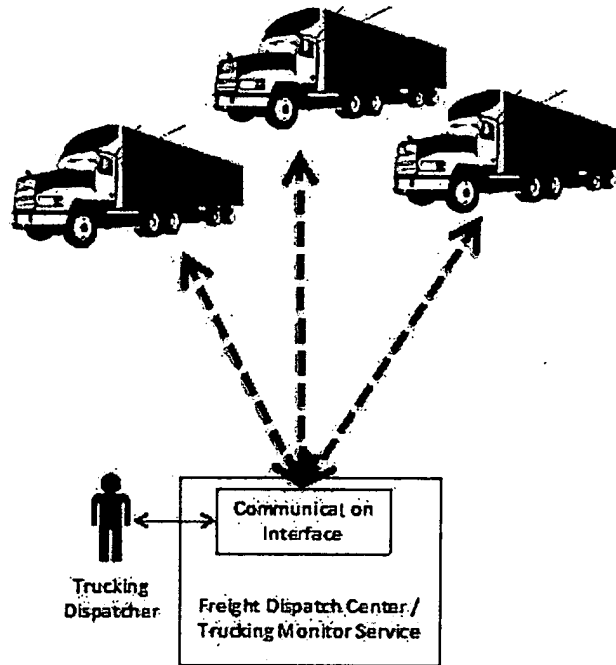

*Conventional System - Point-to-Point Network*

114. With the MacroPoint invention, however, all location information is retrieved and determined by the Location Information Provider from the communication device and correlated to the vehicle or freight carried by the vehicle by the system. In other words the Location Information Provider is the Hub for communication regarding location information of the communication device between the freight company and the vehicles.

DECLARATION OF IVAN ZATKOVICH IN SUPPORT OF MACROPOINT, LLC'S OPPOSITION  
BRIEF TO FOURKITES, INC.'S MOTION TO DISMISS FIRST AMENDED COMPLAINT

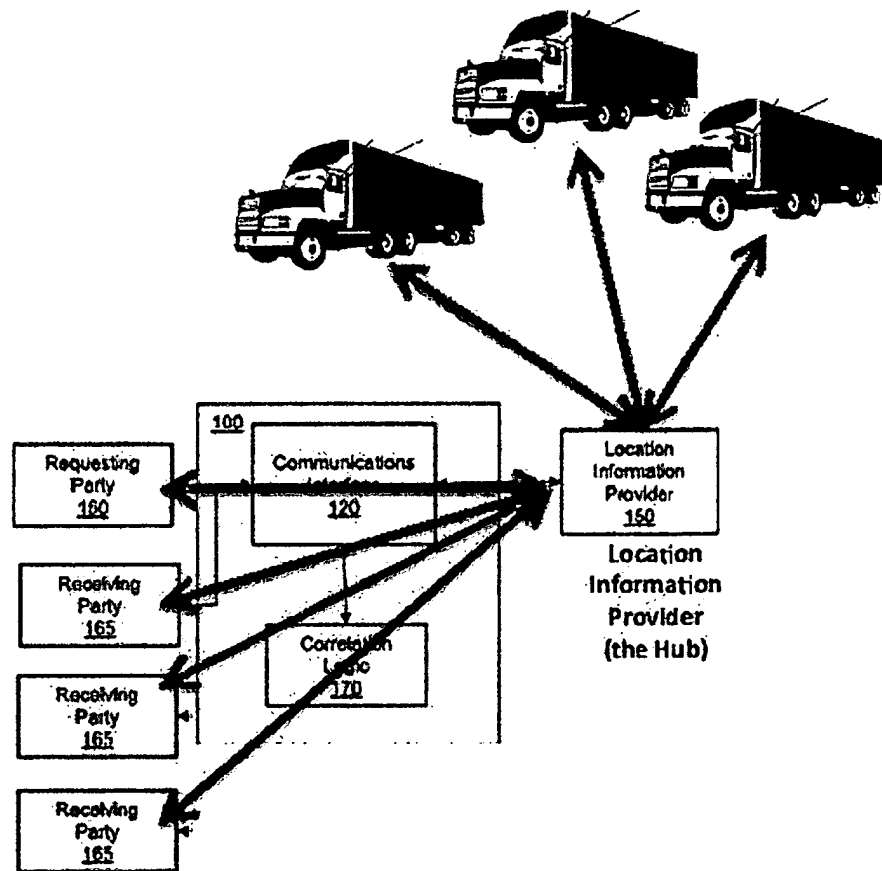

*MacroPoint Unconventional System – Hub Network*

iii. The third party Location Information Provider allows Heterogeneous location technology

115. Another significant difference between a conventional system and the MacroPoint invention is that a conventional system is limited to a single method of location determination. The conventional system must rely on whatever method is standardized for the trucking company and their vehicles. For example, if the trucking company uses manual radio communication to report the location of the vehicle, that is what they are limited to. If the trucking company has installed GPS units in each truck, then that is what they are limited to.

DECLARATION OF IVAN ZATKOVICH IN SUPPORT OF MACROPOINT, LLC'S OPPOSITION  
BRIEF TO FOURKITES, INC.'S MOTION TO DISMISS FIRST AMENDED COMPLAINT

116. The introduction of a third party Location Information Provider however, allows a combination of one or more technologies for determining location. For example, if the Location Information Provider is a Wireless Service Provider (such as AT&T), that service provider can generate the vehicle's location using a single Cell Tower ID, or Cell Tower Triangulation, or GPS if the Trucker's mobile device contains a GPS receiver. (see e.g. '943 patent 8:6-13, and 6:53-67, and 7:7-30)

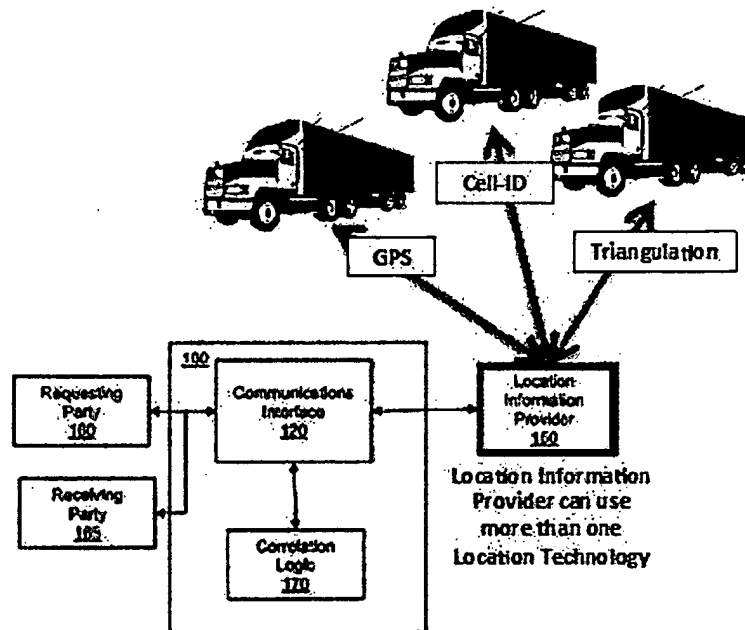

**MacroPoint - Unconventional System**  
*(Multiple) Heterogeneous Location Technology*

117. The Location Information Provider can also alternate between methods depending where the truck is and what provides the best reception. For example, if there is strong satellite reception they may use GPS. If there is a strong tower connection (with multiple towers) and weak satellite reception then they can use Cell Tower Triangulation. If there is very poor reception except for a single cell tower, then they can approximate the location using that single



DECLARATION OF IVAN ZATKOVICH IN SUPPORT OF MACROPOINT, LLC'S OPPOSITION  
BRIEF TO FOURKITES, INC.'S MOTION TO DISMISS FIRST AMENDED COMPLAINT

cell tower. Overall, the ability to use one or more location methods enhances the continuous monitoring capability with the MacroPoint invention.

**iv. Automated response provides consent and continuous capture of location information for real-time monitoring.**

118. In the freight tracking industry, as with the MacroPoint invention to, it is an objective to provide freight location information on a real-time basis.

“In one example application of the use of location information, carriers, shippers, freight hauling services providers, third-party logistics service providers and courier services providers as well as other logistics and freight service providers (freight hauling) benefit from monitoring the location of vehicles in their fleets or under contract. **Monitoring the location of vehicles helps improve efficiency because it allows for real-time or near real-time decision making** when matching loads with vehicles.”

[‘943 patent, 1:18-26]

119. To this end, the MacroPoint patents teach a method for continuously monitoring of vehicle location information at frequent intervals (e.g. every 15 minutes):

The user interface 800 further displays the Monitoring Term, which corresponds to the total amount of time (e.g., 2 hours) that the location of the associated vehicle will be monitored. The user interface 800 further displays the Monitoring Interval, which **corresponds to how often within the Monitoring Term (e.g., every 15 minutes) the location of the vehicle is updated.**

[‘943 patent, 14:58-64]

120. All independent claims of the MacroPoint patents, however, require consent, as a form of privacy protection, to be given by the owner or user of the communication device correlated with the vehicle or freight carried by the vehicle anytime a location request is made.

The following is representative ‘consent’ limitation in claim 1 of the ‘943 patent:

“receiving from the communications device a third signal including **data indicative of consent from the user** to the

DECLARATION OF IVAN ZATKOVICH IN SUPPORT OF MACROPOINT, LLC'S OPPOSITION  
BRIEF TO FOURKITES, INC.'S MOTION TO DISMISS FIRST AMENDED COMPLAINT

obtaining of the location information of the communications device;"

121. The consent can be received from the owner or user of the communications device and stored in the system. Each time a request that requires obtaining or transmitting the location information of the communication device is received, the system can check to confirm that consent has been given and before location information is obtained or transmitted.

122. In this way the MacroPoint invention provides the unconventional feature of both protecting the privacy of the vehicle user, and still providing real-time continuous monitoring of location of a vehicle or freight carried by a vehicle.

**v. The claims amount to significantly more than an abstract idea.**

123. In my opinion, one of skill in the art in March 2012 would understand that the claims are not directed simply to carrying out the well-known steps of tracking freight. Rather, they are directed to a novel system that integrate the unconventional components of:

- a. Creating an "open system" allowing the sharing of location information with multiple parties through a central Location Information Provider.
- b. Defining an unconventional Hub-based network to provide the physical connectivity needed to integrate a third party Location Information Provider to manage / arbitrate all communications between the vehicles and the requestors and receivers of location information.
- c. Enabling the use of Heterogeneous (multiple types of) location technology through the third party Location Information Provider.

DECLARATION OF IVAN ZATKOVICH IN SUPPORT OF MACROPOINT, LLC'S OPPOSITION  
BRIEF TO FOURKITES, INC.'S MOTION TO DISMISS FIRST AMENDED COMPLAINT

- d. Maintaining a continuous real-time monitoring of freight location while protecting privacy through automated consent of a user or owner of a communication device that is correlated to a vehicle or freight carried by a vehicle.

**IX. REBUTTAL TO DEFENDANT'S ASSERTIONS**

**A. MacroPoint Patents teach significantly more than organizing human activity (*Cybersource*)**

124. FourKites asserts in their Motion to Dismiss that the MacroPoint patents claim an abstract idea of Tracking Freight. Specifically:

The claims of the patents-in-suit are directed to the basic idea of tracking freight: (1) receiving a request for the location of freight; (2) asking the truck in possession of that freight where it is; and (3) reporting the location of the truck.

[FourKites' Motion to Dismiss, at pg. 14]

125. FourKites also asserts "the claims 'use' a computer, but they are nothing more than a method of organizing a prior-existing, basic human activity" citing *Cybersource Corp. v. Retail Decisions*.

126. This is not correct. The background and prior art described in the MacroPoint patents' specifications identify a closed system where a GPS receiver is installed in each truck and the trucks position is relayed directly to a trucking dispatch center or vehicle monitoring service. These prior art "conventional systems" may fit the description asserted by FourKites of 1) receiving a request for the location of freight 2) asking the truck where it is, and 3) reporting the location of the truck. The MacroPoint patents, however, teach significantly more than that.

127. As described and cited above, the MacroPoint patents teach a new open architecture. This open architecture MacroPoint patents used an independent third party

DECLARATION OF IVAN ZATKOVICH IN SUPPORT OF MACROPOINT, LLC'S OPPOSITION  
BRIEF TO FOURKITES, INC.'S MOTION TO DISMISS FIRST AMENDED COMPLAINT

Location Information Provider as the central source of location information that can be utilized simultaneously by multiple users (e.g. dispatchers, individual clients and shippers that have freight on the vehicle).

128. A third party Location Information Provider also removes the burden of manually communicating with the driver, or required the installation of a location device on the vehicle. The third party Location Information Provider automates the requesting to provide real-time 'continuous' location information accessible simultaneously to multiple users and recipients of that information.

129. The MacroPoint patents also describes a specific sequence of communication steps needed to integrate the third Party Location Information Provider with the multiple users (requesters and recipients) of that Location Information, that involves:

- a. requesting location information by one or more requesters;
- b. notifying the communication device on the vehicle;
- c. obtaining consent either explicitly or automatically from the user of the vehicle;
- d. requesting the location from the third party Location Information Provider; and
- e. receiving the location information by one or more receivers.

130. The fact that this system integrates all the components required to carry out these steps, and can perform these operations for multiple requesters and recipients simultaneously and in real time is significantly more than organizing human activities. In fact, it would not be feasible for a human or humans to perform these steps and respond to multiple requesters and receivers of location information in real-time.

DECLARATION OF IVAN ZATKOVICH IN SUPPORT OF MACROPOINT, LLC'S OPPOSITION  
BRIEF TO FOURKITES, INC.'S MOTION TO DISMISS FIRST AMENDED COMPLAINT

131. Therefore, the MacroPoint Patents teach significantly more than organizing human activity.

**B. MacroPoint Patents teach significantly more than sending, receiving, and correlating (*Ultramercial*)**

132. FourKites asserts in its Motion to Dismiss “the [MacroPoint patent] claims here are like the claims invalidated by the Federal Circuit in *Ultramercial*, which was on appeal from a Rule 12(b)(6) dismissal.” Specifically FourKites asserts:

Receiving a request, providing information over the Internet, and associating messages with products are no different than receiving signals, transmitting signals, and correlating location information. In each case the claims are directed to nothing more than a collection of steps for sending, receiving, and correlating information—i.e., directed to an abstract idea.

[FourKites' Motion to Dismiss, at pg. 14]

133. I disagree. FourKites is selectively citing only the initial words from some of the claim limitations that state transmitting, receiving, and correlating. FourKites, however, does not look at the entire claim limitations or the entire claims themselves.

134. While claim 1 does include, “(1) receiving signals; (2) transmitting signals; (3) and correlating information,” FourKites analysis is flawed. Specifically, claim element 1.d includes the limitation of consent.

[d] receiving from the communications device a third signal including data indicative of **consent** from the user to the obtaining of the location information of the communications device;

[‘943 patent 21:12-32, as numbered in FourKites Motion to Dismiss, at pgs. 3-4, emphasis added]

DECLARATION OF IVAN ZATKOVICH IN SUPPORT OF MACROPOINT, LLC'S OPPOSITION  
 BRIEF TO FOURKITES, INC.'S MOTION TO DISMISS FIRST AMENDED COMPLAINT

135. Implicit in consent are the further limitations of potential denial. If the user denies consent, then FourKites abstract idea cannot be performed. Consent must be granted prior to obtaining the location information of the communications device.

136. If we look at the entire claims, a person of ordinary skill in the art will find an implicitly ordered combination of limitations defining a very specific communication protocol. This communication protocol dictates a specific way in which each component of the system or method must communicate and process information with the components of the system and method, which in turn defines a specific network architecture. The Location Information Provider is the hub of all communications between the vehicle and the requestor and the recipient, which is an unconventional solution. The requestor can also be different than the receiver, also unconventional. Lastly, there can be multiple receivers of the location information, also unconventional..

137. In addition to defining these unconventional steps (that are present in some form or other in all of the independent claims of the MacroPoint patent, there is a specific order and sequence in which these communication and processing steps must be carried out. For example, the following table shows representative claim 1 from the '943 patent and how their ordered combination exists and a particular protocol, which also amounts to significantly more than an abstract concept:

<b>'943 Patent Claim 1 Limitations</b>	<b>Order of the steps</b>
1. A computer implemented method for indicating location of freight carried by a vehicle, the method comprising:	

DECLARATION OF IVAN ZATKOVICH IN SUPPORT OF MACROPOINT, LLC'S OPPOSITION  
BRIEF TO FOURKITES, INC.'S MOTION TO DISMISS FIRST AMENDED COMPLAINT

<b>'943 Patent Claim 1 Limitations</b>	<b>Order of the steps</b>
correlating the freight to a communications device;	<b>Step 1b –determining the communication device</b> While the freight is identified in the request, the communication device is the ultimate source of the location information. A person of ordinary skill in the art would know that the communication device associated with the freight also can change during transport.
receiving a first signal including data representing a request for information regarding the location of the freight;	<b>Step 1a –the initial location request</b> This step begins the whole process of monitoring the freight location by the requester. The requestor of freight location information initiates a request for the claimed system to locate their freight.
transmitting to the communications device a second signal including data that prompts an automated message to be communicated to a user of the communications device, the automated message representing a notice communicating to the user of the communications device that the location information of the communication device will be obtained;	<b>Step 2 – requesting consent from the user/ communication device.</b> This step provides a notification requesting consent to release the location information of the freight, and there for of the vehicle user (driver) itself.
receiving from the communications device a third signal including data indicative of consent from the user to the obtaining of the location information of the communications device;	<b>Step 3 – obtaining consent from the user/ communication device.</b> This step returns consent to commence monitoring the location of the communication device. The MacroPoint invention teaches embodiments where this is performed explicitly by the vehicle user, or implicitly by allowing the system to reply automatically within a certain criteria controlled by the vehicle user (e.g. between the hours of 9:00 and 5:00).
transmitting a fourth signal to a location information provider, the fourth signal including data representing a request for location information of the communications device, wherein the location information provider corresponds to a party or device other than the communications device and the location information provider corresponds to at least one of:	<b>Step 4a Issuing a location request</b> from the third party Location Information Provider to the communication device, if the consent is forthcoming,

DECLARATION OF IVAN ZATKOVICH IN SUPPORT OF MACROPOINT, LLC'S OPPOSITION  
BRIEF TO FOURKITES, INC.'S MOTION TO DISMISS FIRST AMENDED COMPLAINT

'943 Patent Claim 1 Limitations	Order of the steps
a wireless service provider providing wireless service to the communications device, a third party that obtains the location information of the communications device from the wireless service provider providing wireless service to the communications device, and a party that has access to the location information of the communications device but is other than the wireless service provider or the third party that obtains the location information of the communications device from the wireless service provider;	<b>Step 4b Requiring a specific embodiment of the Location Information Provider</b> , in the claim language, to be one of three alternatives.
receiving a fifth signal from the location information provider, the fifth signal including data representing the location information of the communications device;	<b>Step 5a</b> The Location Information Provider has received the location information of the communications device.
correlating the location information of the communications device to the location of the freight based at least in part on the correlation between the freight and the communications device; and	<b>Step 5b the communication device is correlated with freight</b> using at the least the information obtained in 1b above.
transmitting a sixth electronic signal including data representing the location of the freight.	<b>Step 6 sending the location information</b> to at least one of the receivers.

**C. MacroPoint claims are not like *Wireless Media Innovations Freight Monitoring* claims**

138. FourKites has asserted that the MacroPoint claims are directed to the same underlying abstract idea as the patents in the *Wireless Media Innovations* case.



DECLARATION OF IVAN ZATKOVICH IN SUPPORT OF MACROPOINT, LLC'S OPPOSITION  
BRIEF TO FOURKITES, INC.'S MOTION TO DISMISS FIRST AMENDED COMPLAINT

The patents there [in *Wireless Media Innovations*] claimed methods “for monitoring location and load status of shipping containers” and “[a] computerized system for monitoring and recording location and load status of shipping containers.” *Id.* at \*2. The district court found the claims were all directed “to the same underlying abstract idea: monitoring locations, movements, and load status of shipping containers within a container receiving yard, and storing, reporting and communicating this information in various forms.” *Id.* at \*7. Just like in *Wireless Media Innovations*, the claims of the patents-in-suit here are directed to monitoring locations and movements, storing them, and reporting or communicating them— i.e., directed to the abstract idea of tracking freight.

[FourKites' Motion to Dismiss, at pgs. 15-16.]

139. This is not correct. Although the MacroPoint claims teach innovations in the same industry (the freight industry), the technology, functionality, and objectives of the MacroPoint claims are very different than *Wireless Media Innovations*. For example, the *Wireless Media Innovations* claims teach no system or method for:

- a. Generating location information
- b. Continuous monitoring of freight location
- c. Third Party Location Information Providers
- d. Providing consent to receive location information
- e. A communication device or network for communicating location information

as do the MacroPoint claims.

140. The *Wireless Media Innovation* patent claims the monitoring of freight in a very limited and closed environment (a receiving yard) where there is no need for location devices for tracking vehicles travelling thousands of miles as in the MacroPoint environment. The *Wireless Media* claims simply teach the logging of freight as it enters and leaves a receiving yard. This is a process that can easily be done (and is being done) with paper and pen. Whereas the complexity of the MacroPoint claims with real-time monitoring of vehicle location through a

DECLARATION OF IVAN ZATKOVICH IN SUPPORT OF MACROPOINT, LLC'S OPPOSITION  
BRIEF TO FOURKITES, INC.'S MOTION TO DISMISS FIRST AMENDED COMPLAINT

third party Location Information Provider, using a communication network that also has the ability to triangulate location could never be accomplished with paper and pen.

141. Therefore, the comparison of the *Wireless Media Innovation* claims with the MacroPoint claims is erroneous and misleading.

**D. Implementation on Computer - Alice**

142. FourKites alleges that the “claims of the patents-in-suit here, however, are nothing more than an effort to patent the performance of a task that human beings have always done.” [FourKites’ Motion to Dismiss, at pg. 16] As the basis of this allegation, FourKites describes a conventional closed system, and not the MacroPoint invention.

In the past, merchants or shippers tracked freight with paper logs or other written records. Such tasks are now done on computer, but they remain at their core the basic and fundamental idea of tracking freight. This is not an inventive concept. “[T]he performance of a long-known abstract idea ‘from the pre-Internet world’ . . . using a conventional computer” is not patent-eligible subject matter. *Wireless Media Innovations*, 2015 WL 1810378 at \*11 (finding freight monitoring claims invalid where they were “not tied to any particular novel machine or apparatus, only a general purpose computer, general communication devices, and general vehicles.”).

[FourKites’ Motion to Dismiss, at pg. 16]

143. Contrary to FourKites’ erroneous contention, the MacroPoint Patents are directed to solving the technical problems introduced by a real time, an open system utilizing a third party Location Information Provider that supports multiple requestors and receivers. Specifically,

- a. Using a third party Location Information Provider to create an “open system” for access by multiple parties.

DECLARATION OF IVAN ZATKOVICH IN SUPPORT OF MACROPOINT, LLC'S OPPOSITION  
BRIEF TO FOURKITES, INC.'S MOTION TO DISMISS FIRST AMENDED COMPLAINT

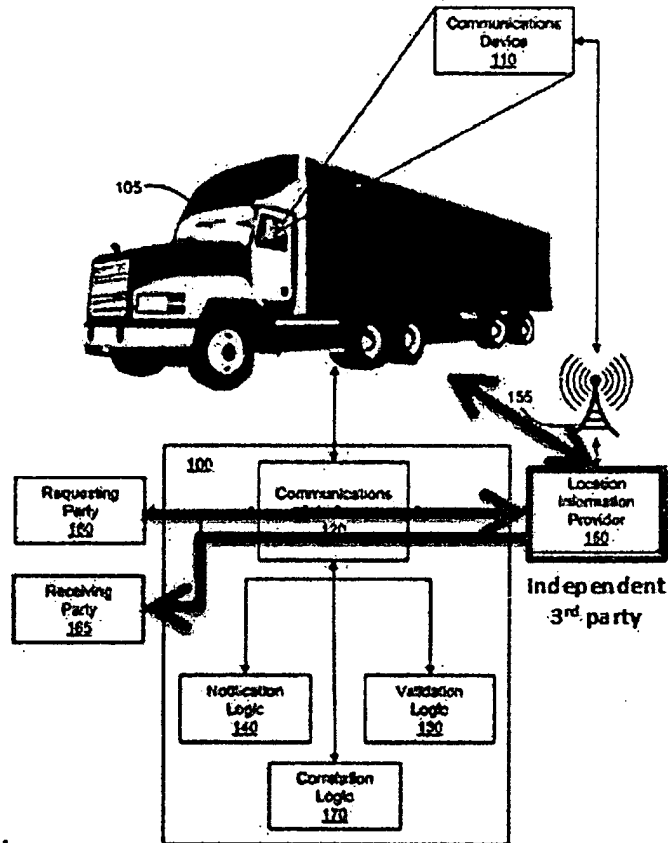

*Independent third party Location Information Provider  
Open System*

- b. Creating a Hub based Network to provide a Multi-channel communication for the multiple requestors and receivers.

DECLARATION OF IVAN ZATKOVICH IN SUPPORT OF MACROPOINT, LLC'S OPPOSITION  
BRIEF TO FOURKITES, INC.'S MOTION TO DISMISS FIRST AMENDED COMPLAINT

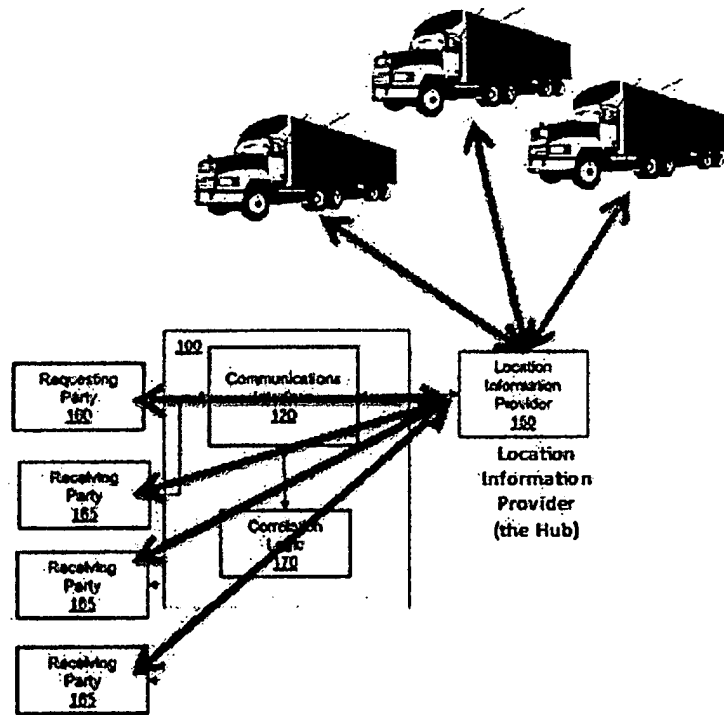

*Hub based Network, multi-channel communications*

- c. Using the third party Location Information Provider to enable Heterogeneous location technology that enables multiple location methods (e.g. GPS, GLONASS, Cell-ID, triangulation, etc.).

DECLARATION OF IVAN ZATKOVICH IN SUPPORT OF MACROPOINT, LLC'S OPPOSITION  
BRIEF TO FOURKITES, INC.'S MOTION TO DISMISS FIRST AMENDED COMPLAINT

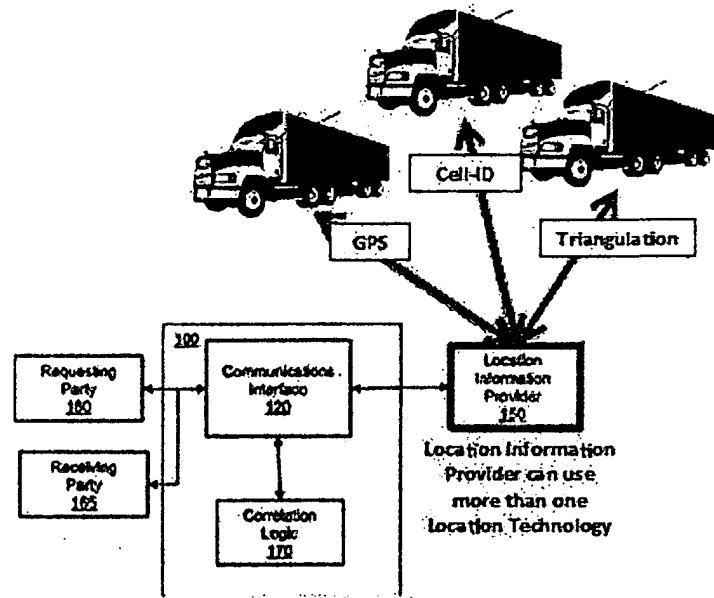

*(Multiple) Heterogeneous Location Technology*

- d. Providing Automated response allows for consent and continuous capture of location information for real-time monitoring.

DECLARATION OF IVAN ZATKOVICH IN SUPPORT OF MACROPOINT, LLC'S OPPOSITION  
BRIEF TO FOURKITES, INC.'S MOTION TO DISMISS FIRST AMENDED COMPLAINT

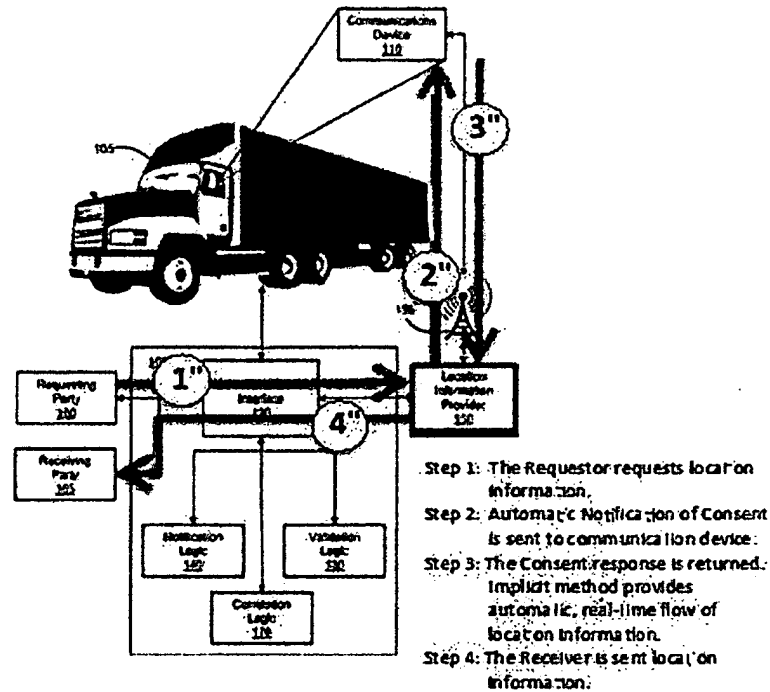

*Continuous information – automated notification & consent*

144. These are elements that are present in all independent claims of the MacroPoint patents. These elements, among others, represent activities that are significantly more than an abstract idea.

**E. Generic Computer Components**

145. FourKites lists the ways the recitation of generic computer components does not make an abstract idea patent eligible. [FourKites' Motion to Dismiss, at pgs. 17-18.] FourKites, however, fails to accuse the MacroPoint patents as reciting generic computer components. Therefore, FourKites makes no assertion that the MacroPoint Patents are invalid for this reason.

**F. Inventive Concepts of the MacroPoint Patents – Technical Solutions to Problems Rooted in Technology**

146. FourKites alleges that Patents-in-Suit do not include an inventive concept.

DECLARATION OF IVAN ZATKOVICH IN SUPPORT OF MACROPOINT, LLC'S OPPOSITION  
BRIEF TO FOURKITES, INC.'S MOTION TO DISMISS FIRST AMENDED COMPLAINT

The claims of the patents-in-suit do not include the "something more" that would transform them into patent-eligible inventions. See Alice, 134 S. Ct. at 2354 (quoting Mayo, 132 S. Ct. at 1303).

[FourKites' Motion to Dismiss, at pg. 18.]

147. To prove the negative of absent inventive concepts, FourKites makes conclusory statements about all the claims of the Patents-in-Suit. For example FourKites fails to individually evaluate each claim limitation of the Patents-in-Suit to determine whether they are representative of an inventive concept or not. In other words, FourKites allegation that the Patents-in-Suit do not include an inventive concept is unsupported.

...all of the claims of the patents-in-suit recycle some combination of seven basic components: (1) sending / receiving; (2) correlating; (3) using or not using GPS; (4) exposing and/or interfacing with an exposed application programming interface; (5) specifying to whom location information is sent; (6) specifying from whom location information is obtained; and (7) displaying a representation of the location information. None of these components, alone or in any combination, supply an inventive concept. Therefore all of the claims of all of the patents-in-suit are invalid.

[FourKites' Motion to Dismiss, at pg. 19.]

148. To the contrary, the limitations of the MacroPoint Patents provide the inventive concepts of providing technical solutions to problems rooted in technology. In particular,

- a. Using a third party Location Information Provider to create an "open system" for access by multiple parties.

DECLARATION OF IVAN ZATKOVICH IN SUPPORT OF MACROPOINT, LLC'S OPPOSITION  
BRIEF TO FOURKITES, INC.'S MOTION TO DISMISS FIRST AMENDED COMPLAINT

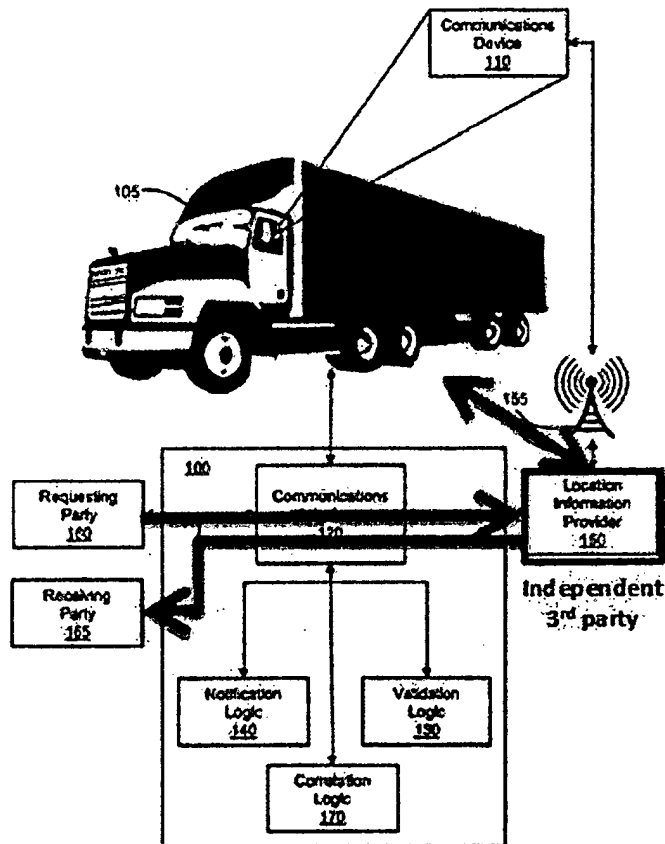

*Independent third party Location Information Provider  
Open System*

- b. Creating a Hub based Network to provide a Multi-channel communication for the multiple requestors and receivers.



DECLARATION OF IVAN ZATKOVICH IN SUPPORT OF MACROPOINT, LLC'S OPPOSITION  
BRIEF TO FOURKITES, INC.'S MOTION TO DISMISS FIRST AMENDED COMPLAINT

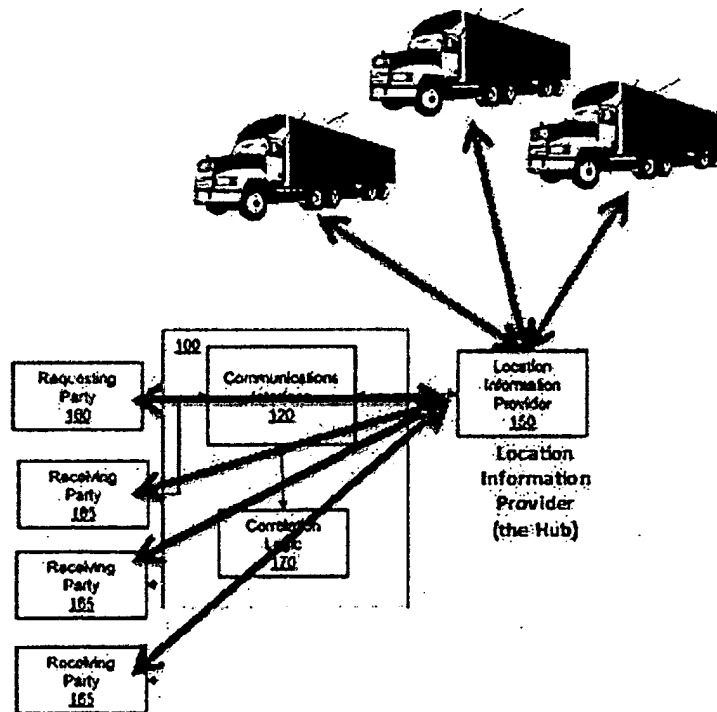

*Hub based Network, multi-channel communications*

- c. Using the third party Location Information Provider to enable Heterogeneous location technology that enables multiple location methods (e.g. GPS, GLONASS, Cell-ID, triangulation, etc.).

DECLARATION OF IVAN ZATKOVICH IN SUPPORT OF MACROPOINT, LLC'S OPPOSITION  
BRIEF TO FOURKITES, INC.'S MOTION TO DISMISS FIRST AMENDED COMPLAINT

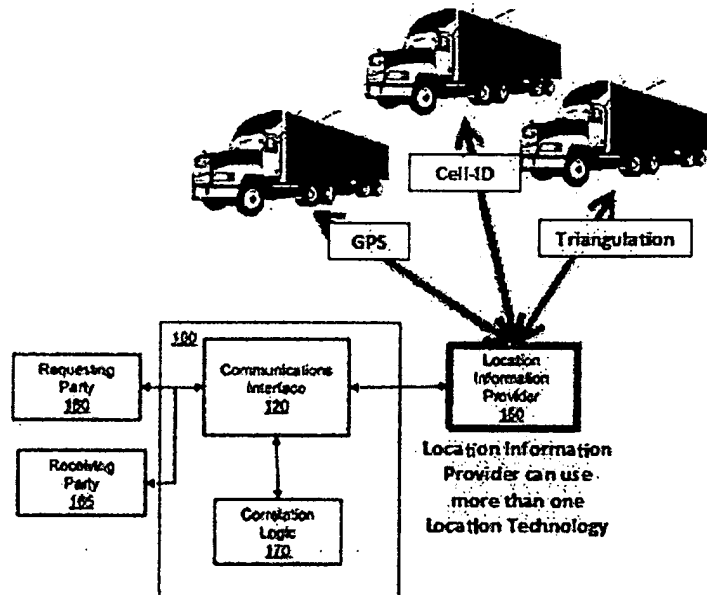

*(Multiple) Heterogeneous Location Technology*

- d. Providing Automated response allows for consent and continuous capture of location information for real-time monitoring.

DECLARATION OF IVAN ZATKOVICH IN SUPPORT OF MACROPOINT, LLC'S OPPOSITION  
BRIEF TO FOURKITES, INC.'S MOTION TO DISMISS FIRST AMENDED COMPLAINT

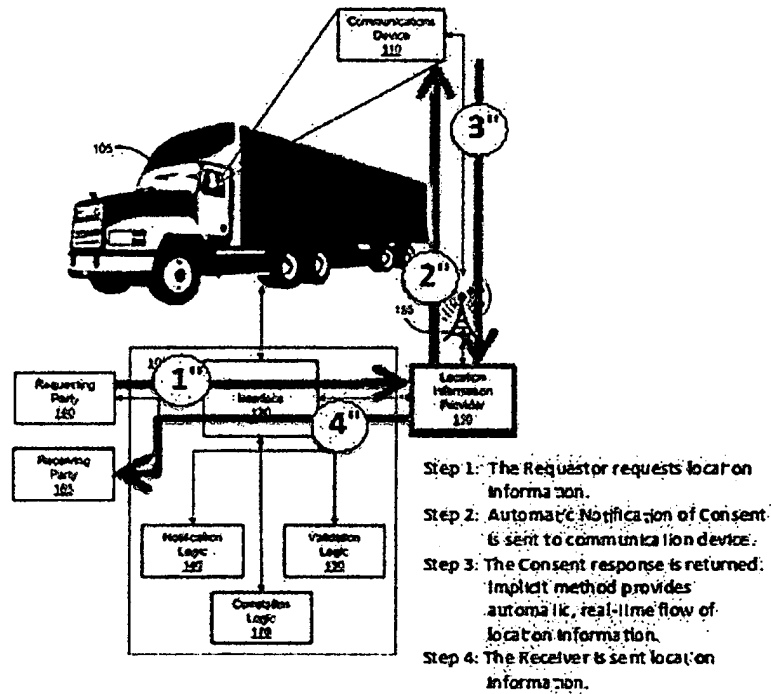

*Continuous information – automated notification & consent*

149. These are elements that are present in all independent claims of the MacroPoint patents. These elements, among others, represent activities that are significantly more than an abstract idea.

**X. COMPARISONS OF THE MACROPOINT PATENT ELIGIBLE EXAMPLES**

150. The previous sections identify how the FourKites assertions of the Subject-Matter Eligibility are overly simplified, mischaracterize the concepts of the MacroPoint invention, and incorrectly compares the MacroPoint claims. The following are examples from the USPTO Interim Eligibility Guidance citing decisions of eligible claims that I believe are more representative of the claims and inventive concepts of the MacroPoint Patents.

DECLARATION OF IVAN ZATKOVICH IN SUPPORT OF MACROPOINT, LLC'S OPPOSITION  
BRIEF TO FOURKITES, INC.'S MOTION TO DISMISS FIRST AMENDED COMPLAINT

**A. The MacroPoint Patents Address Technical Problems Requiring a Technical Solution (*DDR Holdings*)**

151. Example #2 of the USPTO Interim Eligibility Guidance references the decision in the *DDR Holdings, LLC v. Hotels.com* case. In the patent-in-suit, the claimed invention differs from other claims found by the courts to recite abstract ideas in that it does not “merely recite the performance of some business practice known from the pre-Internet world along with the requirements to perform it on the Internet. Instead, the claimed solution is necessarily rooted in computer technology in order to overcome a problem specifically arising in the realm of computer networks.”

152. The MacroPoint patents require a technical solution in order to solve technical problems created by the requirements of an unconventional innovative open system. This arises from the need to create a network that integrates the third party Location Information Provider with the other parties to and components of the system (e.g. multiple location requestors, multiple receivers/clients/shippers). The technical solution also requires the automation of retrieving location information and of obtaining consent in a manner that achieves real-time continuous location monitoring. The MacroPoint patents teach the ability to generate location information via Heterogeneous Location Technology, rather than rely on whatever single location method is present in the vehicle. The third party Location Information Provider can offer one or more methods of locating the vehicle based on whatever method is appropriate for locating that vehicle at that time.

153. Each of these technical problems requires a separate technical solution that is identified in the MacroPoint patents.

DECLARATION OF IVAN ZATKOVICH IN SUPPORT OF MACROPOINT, LLC'S OPPOSITION  
BRIEF TO FOURKITES, INC.'S MOTION TO DISMISS FIRST AMENDED COMPLAINT

- a. Using a third party Location Information Provider to create an "open system" for access by multiple parties.

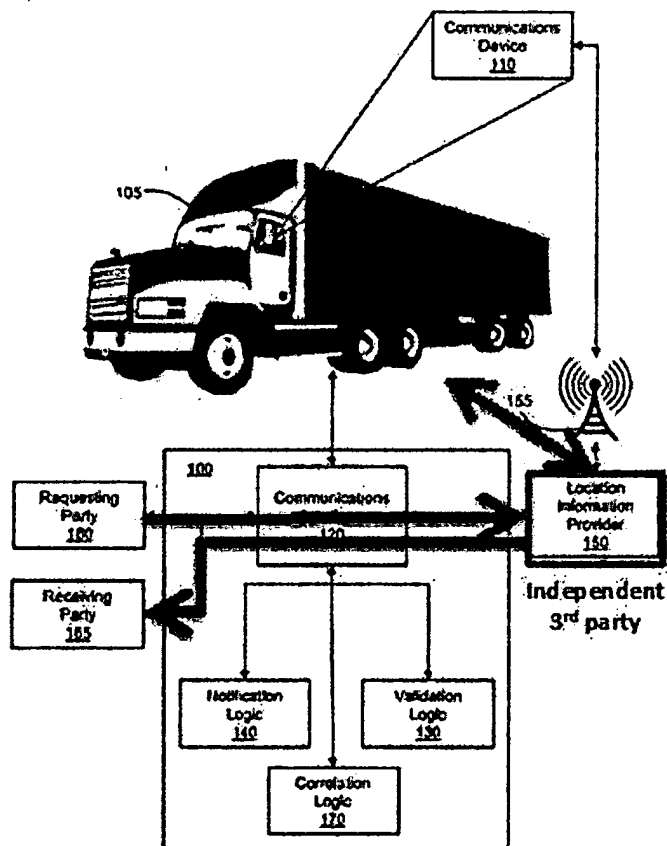

*Independent third party Location Information Provider  
Open System*

- b. Creating a Hub based Network to provide a Multi-channel communication for the multiple requestors and receivers.

DECLARATION OF IVAN ZATKOVICH IN SUPPORT OF MACROPOINT, LLC'S OPPOSITION  
BRIEF TO FOURKITES, INC.'S MOTION TO DISMISS FIRST AMENDED COMPLAINT

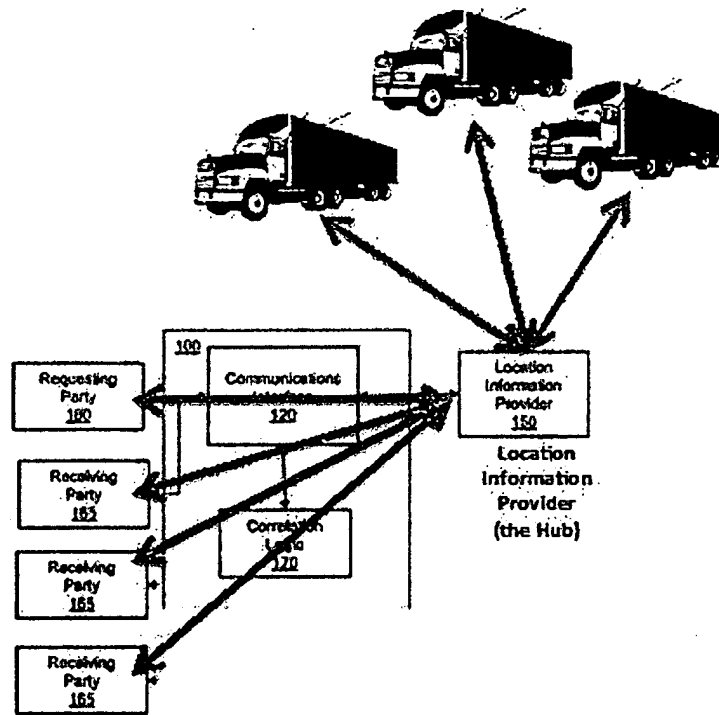

*Hub based Network, multi-channel communications*

- c. Using the third party Location Information Provider to enable Heterogeneous location technology that enables multiple location methods (e.g. GPS, GLONASS, Cell-ID, triangulation, etc.).

DECLARATION OF IVAN ZATKOVICH IN SUPPORT OF MACROPOINT, LLC'S OPPOSITION  
BRIEF TO FOURKITES, INC.'S MOTION TO DISMISS FIRST AMENDED COMPLAINT

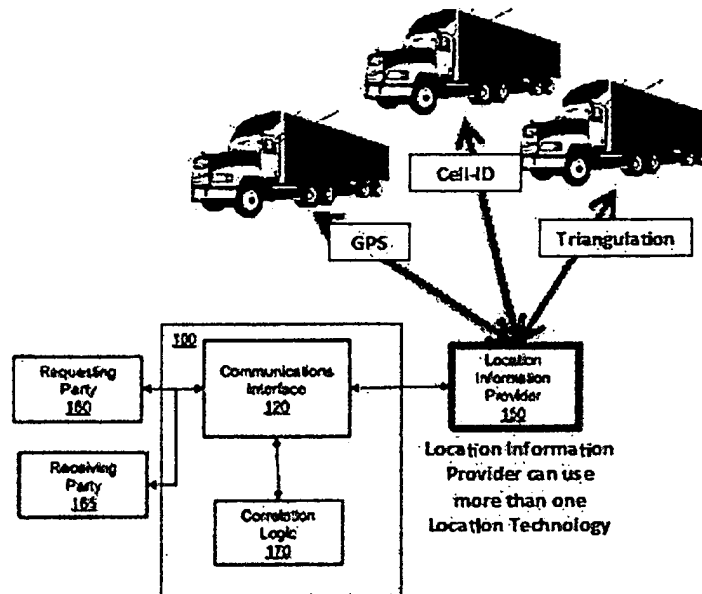

*(Multiple) Heterogeneous Location Technology*

- d. Providing Automated response allows for consent and continuous capture of location information for real-time monitoring.

DECLARATION OF IVAN ZATKOVICH IN SUPPORT OF MACROPOINT, LLC'S OPPOSITION  
BRIEF TO FOURKITES, INC.'S MOTION TO DISMISS FIRST AMENDED COMPLAINT

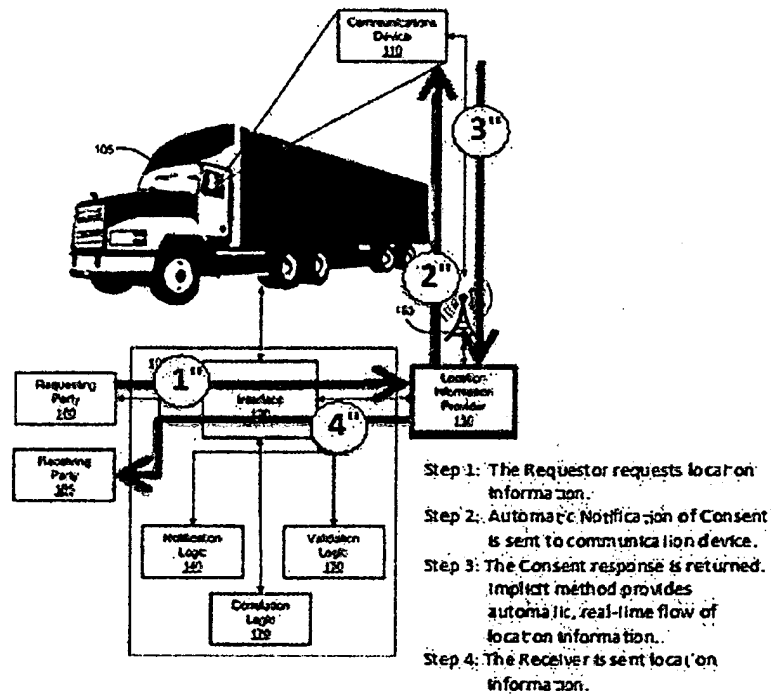

*Continuous information – automated notification & consent*

- i. Using a third party Location Information Provider to create an “open system” for access by multiple parties.

154. Changing the system architecture to incorporate an independent third party Location Information Provider and allowing that information to be shared with multiple requestors and recipients makes it an open system. Whereas prior conventional systems simply communicated information between the vehicle and a requestor (the freight company or truck monitoring Service).

- ii. Creating a Hub based Network to provide a Multi-channel communication for the multiple requestors and receivers.

155. To resolve the problem technical of integrating the third party Location Information Provider with the other parties in the system, the MacroPoint patents teach the need



DECLARATION OF IVAN ZATKOVICH IN SUPPORT OF MACROPOINT, LLC'S OPPOSITION  
BRIEF TO FOURKITES, INC.'S MOTION TO DISMISS FIRST AMENDED COMPLAINT

for a specific type of network. That network can used both as a means to generate location information (e.g. using triangulation, etc.) and a means to connect the third party Location Information Provider with the other parties (e.g. using a cell/wireless network)

Alternative methods for monitoring location of vehicles include radiolocation techniques including triangulation or multilateration methods that are capable of locating devices in a network..

[ '943 patent, 1:48-50]

The location information provider 150 has access to location of the vehicle 105 or the device 110. In one embodiment, the location information provider 150 is a wireless service provider that provides wireless service in a network 155. In another embodiment, the location information provider 150 is 40 a third party or device that receives the location information of the device 110 from the wireless service provider or from some other party or device.

[ '943 patent, 4:35-42]

**iii. Technical Requirement for Heterogenous Location Technology**

156. The MacroPoint patent and claims require the third party information provider to support one or more methods of generating location information (e.g. GPS, GLONASS, Cell-ID, triangulation, etc.). Providing multiple methods for providing location information is a more reliable system, however it is a technical problem to provide location information to the recipient such that the method of generating or retrieving that information is transparent to the user. Therefore, the specification and claims identify a standardized API interface so that the system provides the location information regardless in the same format regardless of the source of that location information.

DECLARATION OF IVAN ZATKOVICH IN SUPPORT OF MACROPOINT, LLC'S OPPOSITION  
BRIEF TO FOURKITES, INC.'S MOTION TO DISMISS FIRST AMENDED COMPLAINT

iv. **Providing Automated response allows for consent and continuous capture of location information for real-time monitoring.**

157. Since the location information is now centralized with a third party, and can be shared with multiple receivers, the MacroPoint patents must solve the problem of confirming consent from the owner of the communication device (e.g. the vehicle driver). Because the MacroPoint patents require the location information in real-time (i.e. requesting location information frequently) there is the technical problem of receiving the consent every time the location information is requested, without continually interrupting the vehicle driver. The MacroPoint claims require an automated process to notify the user and receive consent:

transmitting to the communications device a second signal including data that prompts an automated message to be communicated to a user of the communications device, the **automated message representing a notice** communicating to the user of the communications device that the location information of the communication device will be obtained;

receiving from the communications device a third signal including **data indicative of consent** from the user to the obtaining of the location information of the communications device;

[ '931 patent, Claim 1 ]

158. The MacroPoint proposed multiple technical solutions for providing explicit consent and automated implicit consent. For example:

In one embodiment, the user is given the option to temporarily revoke consent to the disclosure of location information. For example, a driver may wish to make available his location to a carrier during certain hours during the work week, but may not want the carrier to be able to obtain the driver's location during the weekend. The driver may operate the device 110 to **indicate a date and time when the driver wishes for the monitoring of the location of the vehicle 105 to end or resume.**

[ '943 patent, 9:60-10:1 ]

DECLARATION OF IVAN ZATKOVICH IN SUPPORT OF MACROPOINT, LLC'S OPPOSITION  
BRIEF TO FOURKITES, INC.'S MOTION TO DISMISS FIRST AMENDED COMPLAINT

**B. The MacroPoint claim limitations impose meaningful limitations in the field of Freight Tracking (SiRF Technology)**

159. Example #4 of the USPTO Interim Eligibility Guidance references the decision in the SiRF Technology Inc. v. International Trade Commission. In this example, claim 1 & 2 of the patent-in-suit was determined to fall within the judicial exceptions (an abstract idea) specifically reciting mathematical operations (Step 2A: Yes). However, the claims as a whole were determined to be limited to “a mobile device comprising a GPS receiver, microprocessor, wireless communication transceiver and a display that receives satellite data, calculates pseudo-ranges, wirelessly transmits the calculated pseudo-ranges to the server, receives location data from the server, and displays a visual representation of the received calculated absolute position from the server.” Specifically, “the combination of elements **impose meaningful limits** in that the mathematical operations are applied to improve an existing technology (global positioning) by improving the signal-acquisition sensitivity of the receiver to extend the usefulness of the technology into weak-signal environments and providing the location information for display on the mobile device. All of these features, especially when viewed in combination, amount to significantly more than the judicial exception (Step 2B: Yes).”

160. The MacroPoint claim limitations impose meaningful limitations in the generation of location information for the field of Freight Tracking. Specifically, the MacroPoint patents impose a third party Location Information Provider, that not present in prior conventional systems, in order to support multiple receivers. And also using the third party Location Information Provider to enable one of more location methods including GPS, GLONASS, Cell-ID, Triangulation. Every independent claim has a dependent claim that requires the use of GPS unit for example:

DECLARATION OF IVAN ZATKOVICH IN SUPPORT OF MACROPOINT, LLC'S OPPOSITION  
BRIEF TO FOURKITES, INC.'S MOTION TO DISMISS FIRST AMENDED COMPLAINT

3. The method of claim 1, wherein the location information of the communications device is originally obtained using a method including a technique utilizing a global position system (GPS) satellite receiver that forms part of the communications device.

['098 patent, Claim 3]

161. Every independent claim also has a dependent claim that requires the use of a location technology other than GPS, for example:

4. The method of claim 1, wherein the location information of the communications device is originally obtained using a method including a technique other than a technique utilizing a global position system (GPS) satellite receiver that forms part of the communications device.

['098 patent, Claim 4]

162. The use of one or more location methods improves the ability to continuously monitor the location of freight in real-time. The Location Information Provider can use one or more location methods depending where the vehicle is and what method provides the best reception. For example, if there is strong satellite reception they may use GPS. If there is a strong tower connection (with multiple towers) and weak satellite reception then they can use Cell Tower Triangulation. If there is very poor reception except for a single cell tower, then they can approximate the location using that single cell tower. Overall, the ability to use one or more location methods enhances the continuous monitoring capability.

\* \* \*

DECLARATION OF IVAN ZATKOVICH IN SUPPORT OF MACROPOINT, LLC'S OPPOSITION  
BRIEF TO FOURKITES, INC.'S MOTION TO DISMISS FIRST AMENDED COMPLAINT

**XI. SIGNATURE**

163. All of the statements made in this declaration of my own knowledge are true and all statements made on information and believed are believed to be true. These statements were made with knowledge that willful false statements and the like so made are punishable by fine or imprisonment, or both, under section 1001 of Title 18 of the United States Code.

Dated: Sept. 14, 2015

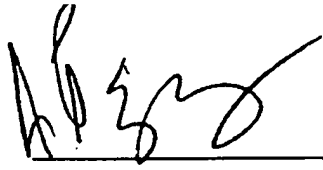
Signature: 

Ivan Zatkovich

**e comp CONSULTANTS**  
 INFORMATION TECHNOLOGY & PATENT LITIGATION  
 TELECOMMUNICATIONS • INTERNET • EFORENSICS

**Ivan Zatkovich**

301 W. Platt St. #365 ■ Tampa, FL 33606 ■ (813) 601-8142 ■ izatkovich@ecompc consultants.com

Ivan Zatkovich is an eBusiness Director and Technology Consultant specializing in Telecommunications, Network and Mobile Communications. Ivan brings over 28 years experience in a diverse set of technologies including, Network Performance Monitoring, VoIP, Mobile Geolocation, and Secure wireless communications. Ivan has been a testifying expert for over 24 cases including 12 Network and Wireless patent litigation cases.



Mr. Zatkovich has implemented Wireless and Network infrastructure for clients including GTE / Verizon, Bell Canada, Qwest telephone, Deutsche Telekom, Citicorp, GEICO.

<b>Director / Project Manager</b>	13 years	Managed 6 to 35 member teams. Software development, systems Integration, critical path management, PMP/CMM methodologies.
<b>Telecommunications, Mobile / Wireless</b>	11 years	Computer Telephony Integration (CTI) since 1984. Call Center, IVR, ACD, VoIP, and Wireless Messaging Systems, Cell phone provisioning and updates (Verizon, Bell Canada, PTT Netherlands, and Mercury Communications).
<b>Network Performance Management</b>	13 years	Network Monitoring and Performance configuration, Network Middleware development, Director of Network support, Network security and optimization. (Digital Equipment, Verizon GTE, Utility Partners)
<b>Messaging &amp; notification systems</b>	7 years	Messaging Gateway for wireless message routing, message identifiers to authenticate Mobile users, VoIP contact and messaging centers, Mesh Network technology, Mobile GUI interfaces for message routing and notification.
<b>Internet, ecommerce,</b>	8 years	Commercial and high volume content websites, streaming media, web marketing and personalization, search engine optimization, Storefront, fulfillment systems, B2B/B2C portals, ERP/supply chain. (Warner Brothers, Caldwell Banker, AAA Travel, Pro Marine)
<b>Expert Witness</b>	9 years	Expert testimony and damage assessment for ecommerce litigation, internet & software copyright, telecommunications. Over 24 cases providing expert reports, depositions, & trial testimony.

**Education:**

B. S. Computer Science 1980 University of Pittsburgh  
 Minor in E.E. digital circuit design  
 Master's study and thesis in Computer Networks,  
 Results published in Byte Magazine

**Sample Case Experience:**

**Bear Creek Technologies v. Verizon et.al**

Jurisdiction: Eastern District of Virginia  
Client: Bear Creek  
Nature of Case: Patent Litigation  
Nature of Engagement: Testifying expert, VoIP, IP based integrated voice, media, and data messaging. Infringement report and Deposition.  
Represented by: Cooley Manion Jones  
Status: Pending MDL aggregation

**3M Futures South Africa v. STD Bank, MDT telecom**

Jurisdiction: South Africa Superior Court, Pretoria  
Client: 3M Futures  
Nature of Case: Patent Litigation  
Nature of Engagement: Testified in South Africa for eCommerce technology, Transaction notification messaging, Credit Card authentication and transaction authorization.  
Represented by: Stema Lubbe, Ltd  
Status: Court ruled in favor of all 36 Infringement and Invalidity rebuttal testimony points. Defendant is appealing

**Nuance Communications v. TellMe Networks (Microsoft)**

Jurisdiction: U.S. District Court, Delaware  
Client: TellMe Networks, A MicroSoft Subsidiary  
Nature of Case: Patent Litigation  
Nature of Engagement: Provided expertise in speech recognition, digital signal pattern matching, and call center technology. Performed prior art investigation, provided opinions on patent validity and non-infringement.  
Represented by: Patterson Belknap Webb & Tyler, LLP  
Status: Expert Reports and deposition completed 2009. Summary Judgment in favor of Defendant 2010.

**Ronald A. Katz v. Fifth Third Bank (and expert for 5 other defendants)**

Jurisdiction: U.S. District Court, Northern California  
Client: Defendants  
Nature of Case: Patent Litigation for Call Center, and Telecom technology  
Engagement: Expertise in Call center systems for Banking, Mortgage, credit cards. Analyze client call center applications, prepare non-infringement and rebuttal reports.  
Status: Open  
Represented by: Vorys LLP, Wood Herron and Evans.

**Professional Experience:**

**2000 to Present**

**Principal Consultant  
eComp Consultants**

**Tampa, FL**

Provide consulting on design and development of software product development, and ecommerce technology. Provide technology consulting and expert support for telecommunications, internet, and ecommerce applications in the areas of:

- Patent portfolio evaluation, market valuation, identification of potential prior art, and licensing opportunities.
- Independent consulting for Alcatel-Lucent (AT&T Bell Labs) to review, recommend, and rate Alcatel's extensive Patent portfolio specifically in the area of telecommunications and web-based ecommerce.
- Patent litigation consulting for telecommunications and internet technology patents.
- Provide mobile geolocation for forensics analysis and event location.
- Development of Mesh Network technology, Mobile GUI interfaces for message routing and notification.
- Commercial websites, search engine, and web marketing strategies.
- Sample clients include: Alcatel-Lucent, LogicLink, NWI Corp, Jones Day, Finnegan Henderson, Fish & Richardson, Cozen O'Connors, Morrison Foerster

**2007 to 2008**

**Global Web Manager  
Smith & Nephew Inc.**

**Clearwater, FL**

Smith & Nephew is a global manufacturer of medical, wound, orthopedic, and surgical supplies. Smith & Nephew has facilities in 33 countries and maintains 35 websites for different product areas and country marketing.

- Designed the Smith & Nephew corporate web architecture for all intranet, extranet, and internet sites.
- Directed a staff of web professionals in developing and managing 35 individual Smith & Nephew websites maintained in the US and 14 countries for both Smith & Nephew clients and internal users.
- Managed and maintain the 650 domains currently owned by Smith & Nephew
- Optimized search engine ranking and website meta tagging.
- Developed corporate technology and IT standards and policies including:
- Created web hosting agreements and IT service contracts (SLAs)
- Defined web development standards
- Researched page ranking, redirection, and domain optimization strategies.

**2002 to 2007**

**eBusiness Director  
Eva-Tone Inc**

**Clearwater, FL**

Eva-Tone is a \$45M commercial multimedia company specializing in ecommerce and marketing solutions, media and content customization, order processing and fulfillment, print & web publishing, CD & DVD manufacturing.

- Set strategic direction of client service offerings in ecommerce and content management.
- Consulted with clients on: web marketing strategy using personalized sales collateral. Defined client profile information to be used to generate customized presentations and brochures.
- Aggressively controlled project scope, managed project timelines, budgets and client expectations.



Curriculum Vitae: Ivan Zatkovich

Senior Consultant – eComp Consultants

- Projects proposed and delivered included:
  - McGraw-Hill – Enterprise Content Management and automated Web publishing system.
  - ProMarine USA – B2B storefront, complex part search, order processing and fulfillment.
  - Resource Rabbit – Sales collateral manager. This system retrieves user preferences and client profile information to generate customized electronic presentations and brochures.
  - AAA Travel – CRM sales collateral system, instant customized brochures, print-on-demand.

1999 to 2002

**eBusiness Engagement Manager**  
**Tanning Technology and IMRGlobal**

Tanning Technology is an international systems integrator specializing in network infrastructure and channel integration for financial markets and the insurance industry. Proposed and managed eBusiness and Internet infrastructure projects focused on client and user personalization, data mining, and web marketing practices.

Client web engagements proposed and managed:

- Eckerd Pharmacy – Developed eBusiness and web marketing for personalized client web content.
- GEICO – Developed a personalized policyholder web service that uses clients' account history and demographics to customize product literature for cross-sell & up-sell opportunities.
- Developed Integrated VoIP contact and messaging center, to cross-utilize call center resources for simultaneous Telephone, IVR, Chat room, and Call Back messaging and notification. (Geico Insurance)
- Hartford Insurance – Integrated 3 tier online claims processing & subrogation with legacy systems
- Citicorp Bank – Designed mortgage and loan payment system; managed sale of loan contracts
- Smith Barney – Developed remote access network infrastructure & wireless PDA financial system
- Medwerks – Created medical insurance clearinghouse, MDs centrally process insurance payments

1996 to 1999

**Director of Network & Customer Support**  
**Utility Partners, Inc.**

**Tampa, FL**

Utility Partners developed and customized utility company software for scheduling service appointments, assigning and routing mobile workforce (field technicians), and dispatching and coordinating resources during power outages.

- Mobile data integration – Develop cellular and wireless data messaging for Mobile Field devices
- MobileUp – Wireless field dispatching system and Geolocation of mobile devices.
- Developed system and network monitors for real-time client system monitoring
- Received trouble calls & provided live client support for the following applications:
  - TroubleUP – Power outage manager
  - Smartnom – Web Gas Auction System for private gas auctions
  - CAS – Customer Appointment and Call Center application

Curriculum Vitae: Ivan Zatkovich

Senior Consultant – eComp Consultants

**1987 to 1996**

**Project Manager: Telecom Software  
GTE Data Services (currently Verizon)**

**Tampa, FL**

GTE was an \$8B Telecommunications company and formed the Commercial Services division to customize their telephone business software to sell to other telephone companies internationally.

- Managed large product implementations for Telecom billing, service order, and Switch management.
- Developed project proposals, and provided client pre-sales support.
- Created project plans, managed resources, and set expectations for customer delivery projects.
- Specific projects managed:
  - Mercury Communication – setup Service Bureau to bill their new intelligent network services.
  - PTT Netherlands – managed \$5M inter-carrier billing project for PTT Netherlands
  - Bell Canada – developed Pricing Plan & Table Management system
  - Deutsche Telekom – designed and developed a German billing prototype system.
  - Received GTE personal best award.

**1980 to 1987**

**Software Engineer / Technical Lead  
Digital Equipment Corp.**

**Maynard, MA**

As Technical Lead, led the development of manufacturing automation and control software. Projects Included:

- Supply Chain, CAD/CAM – Designed system to retrieve parts information from circuit board CAD design. Developed a parts ordering system based on expected volumes.
- Pick & place automation – Automatically program IC insertion machines. Developed system to determine IC insertion order, generate machine instructions, and download program to machine.

As Software Engineer for embedded controllers and video subsystems, designed and developed PDP-11 operating system and device drivers.

- Enhanced high-speed DecNet drivers for Synch, Asynch, and Parallel communications.
- Designed/developed disk firmware and drivers for floppy & Winchester disks.
- Developed and enhanced video controller firmware and layered graphics system for PRO-350.
- Developed Computer Telephony Integration (CTI) product for telephone answering machines.

**Technical Tools & Environments:**

- Unix, Windows, NT, Microsoft .NET, C#, C/C++, VB, Assembler
- Java, Java script, JSP, IBM Websphere, Microsoft Commerce engine, Blue Martini
- SQL, Oracle, Foxpro, DB2, Crystal Reports, Active-Reports, MQ Series, Tuxedo, Documentum, Interwoven

**Certifications & Publications:**

- Industry Speaker: Internet Publishing standards (Momentum conference)
- Department of Justice: Proposal for internet forensics technology
- IBM Websphere – Certified ecommerce Solutions Expert

*Curriculum Vitae: Ivan Zatkovich*

*Senior Consultant – eComp Consultants*

- Byte Magazine – Published Network Design articles
- Sync Magazine – Published Programming Techniques and Tutorials
- IEEE SigGraph – Presented ICGS Computer Graphic Standards for IEEE SigGraph conference.
- CMM & PMP – Project management methodologies
- ISO and ANSI – On International ISO and National ANSI Committees for Disk and Media format standards

***Ivan Zatkovich - Consulting, Testimony & Publications***

---

301 W. Platt Street, #365 ■ Tampa, FL 33606 ■ (813) 601-8142 ■ [ivanzat@ecompc consultants.com](mailto:ivanzat@ecompc consultants.com)

**Companies consulted for in past 5 years:**

- eComp Consultants
- Alcatel – Lucent
- Verisign
- United Illuminating
- Smith & Nephew
- Evatone, Inc
- McGraw Hill
- AAA Travel
- Pro Marine
- Wachovia
- Capitol One
- Network 1 Security Solutions
- Vaud Advisors Social Media Technology Funds

**Certifications & Publications:**

- Industry Speaker: Internet Publishing standards (Momentum conference)
- Department of Justice: Proposal for internet forensics technology
- IBM Websphere – Certified ecommerce Solutions Expert
- Byte Magazine – Published Network Design articles
- Sync Magazine – Published Programming Techniques and Tutorials
- IEEE SigGraph – Presented ICGS Computer Graphic Standards for IEEE SigGraph conference.
- CMM & PMP – Project management methodologies
- ISO and ANSI – On International ISO and National ANSI Committees for Disk and Media format standards

**Court Testimony Experience:**

- Logiclink v. Keylink, CV07-1056-DOC(MLGx) (C.D. Cal.)  
Patent infringement dispute for the Plaintiff, concerning eCommerce for Kiosks for Hotel Business centers. Bench trial: The judge ruled in favor of, and awarded damages to the Plaintiff
- 3M Future Africa (PTY) LTD v. The Standard Bank of South Africa LTD, MTN Group Limited and MTN Mobile Money SA (PTY) LTD, Case #: Patent 2002/2337 (South African High Court) Testifying expert patent infringement and patent validity for the Plaintiff for Online Payments Technology. Bench trial: Testified on the stand for 2.5 days (bench trial). The judge ruled in favor of the Plaintiff on all points of contention for both Infringement and Patent Validity and cited the expert's opinion in each ruling.
- Black Hills Media, LLC v. Samsung, et al. INV# 337-TA-882 [ITC case]  
*Samsung, LG, Panasonic, Toshiba, Sharp*  
Testifying Expert on infringement and patent validity for the plaintiff, regarding media streaming, playlists, and geolocation technology. Testified at the ITC hearing. The ITC administrative judges ruled that the accused products did meet the limitation of the claims,

**e**compCONSULTANTS  
INFORMATION TECHNOLOGY & PATENT LITIGATION  
TELECOMMUNICATIONS • INTERNET • EFORENSICS

but where not in an infringing state at the time of importation. None of the 5 patents in suite were ruled as invalid.

- *Swapalease, Inc. v. Sublease Exchange.com, Inc.*, 1:07 CV 00045-SSB (S.D. Ohio 2007)  
Expert for Plaintiff on infringement for the Plaintiff. Patent litigation involving online auto leasing technology. Testified at *Markman* Hearing. The judge accepted 3 out of 5 of the Plaintiff's claim constructions.
- *Holt Holt v US Government* – Criminal Cell phone forensics - Testifying expert for the defendant on cell phone location and source of illegal material on the defendants device (27 counts). Jury Trial: Testified that the source of 20 if the illegal items was not as a result of the defendants actions, therefore the jury only found the defendant guilty of 7 counts of illegal material.

**Case History:**

Within the past five years, I have testified and/or provided expert services in the following matters (the underlined party identifies which party I was retained by):

- *Bid For Position v. AOL, Google, Microsoft, MIVA, et.al.* 2:07-cv-582 JBF/TEM (E.D. VA 2010) (settled 2008)  
Expert for Defendant MIVA on Patent Invalidity for Internet Search Engine technology. Provided expert invalidity report regarding the auctioning of keywords in paid searches.
- *Imhoff Associates v America's Criminal Defense* (S.D. CA) (settled 2009)  
Expert for Defendant ACD for accused Internet Search Engine mis-direction (fraud). Provided expert consulting and identified the unintentional actions of the defendant which caused the search mis-direction.
- *Zamora v. CBS Radio et.al.* 09-20940-CIV-MORENO (S.D. FL 2010) (settled 2010)  
*Last.fm, Ltd., CBS Radio, Inc., CBS Corp., Slacker, Inc., Pandora Media, Inc., Rhapsody America LLC, Realnetworks, Inc., DKCM, Inc., AOL, LLC, Accuradio, LLC, Yahoo! Inc. and Soundpedia, Inc.*  
Expert for Plaintiff on Patent Infringement for Internet Radio Technology. Provided expert report and deposition regarding the use of streaming media and Web Radio players.
- *Nuance v. Tellme (a Microsoft subsidiary)* C.A. No. 06-105-slr (S.D. Del 2009) (settled 2010)  
Expert for Defendant on Speech Recognition software. Provided expert report and deposition on non-infringement and invalidity for speech recognition used in automated phone directories.
- *TGIP, Inc. v. AT&T Corp, IDT*, 512 F. Supp. 2d 727 (E.D. Tex. 2007) (settled 2007).  
Expert for Defendant on non-infringement. Patent and prior art dispute concerning call processing center and service provisioning in which I analyzed telephone network, call processing center, and call routing patents; developed detailed non-infringement chart; and rebutted plaintiff's expert.
- *Swapalease, Inc. v. Sublease Exchange.com, Inc.*, 1:07 CV 00045-SSB (S.D. Ohio 2007) (Pending)  
Expert for Plaintiff on infringement. Patent and prior art dispute concerning commercial auto lease web site. Expert infringement report, testified at *Markman* Hearing.
- *Ronald A. Katz v. DHL Express*, 2:2007 CV 02192 (N.D. Cal.)  
Patent infringement dispute concerning call processing center and call routing patents. Developed non-infringement reports and deposed.

**e**compCONSULTANTS

INFORMATION TECHNOLOGY & PATENT LITIGATION  
TELECOMMUNICATIONS • INTERNET • EFORENSICS

- *Ronald A. Katz v. Cox Communications*, 2:2007 CV 02299 (N.D. Cal.)  
Patent infringement dispute concerning call processing center and call routing patents. Developed non-infringement reports and deposed.
- *Ronald A. Katz v. Earthlink*, 2:2007 CV 02325 (N.D. Cal.). Patent infringement dispute concerning call processing center and call routing patents. Developed non-infringement reports and deposed.
- *Ronald A. Katz v. Fifth Third Bank*, 2:2007 CV 04960 (N.D. Cal.)  
Patent infringement dispute concerning call processing center and call routing patents. Developed non-infringement reports and deposed.
- *Ronald A. Katz v. Huntington National Bank*, 2:2007 CV 04960 (N.D. Cal.)  
Patent infringement dispute concerning call processing center and call routing patents. Developed non-infringement reports and deposed.
- *Ronald A. Katz v. Echostar*, 2:2007 CV 06222 (N.D. Cal.) (pending)  
Patent infringement dispute concerning call processing center and call routing patents. Developed non-infringement reports and deposed.
- *ABC v. ENC, CISCO, WebEx communications, et.al.*, H-06-1032 (S.D. TX.)  
Patent infringement dispute concerning computer remote control, remote command processing, and remote communication. Developed non-infringement and invalidity rebuttal reports and deposed.
- *Logiclink v. Keylink*, CV07-1056-DOC(MLGx) (C.D. Cal.)  
Patent infringement dispute concerning eCommerce for Kiosks for Hotel Business centers. Developed infringement report and invalidity rebuttal report. Trial Testimony.
- *eBay v. IDT corp*, IDT 4:08-cv-4015-HFB (W.D. Ark) (settled 2010)  
Patent infringement. Perform analysis of Voice Over IP providers and prior art candidates; provide non-infringement (suit) and infringement (counter suit) expert reports.
- *i2 Technologies, Inc. v. Oracle Corporation*, 6:09-CV-194-LED (E.D. Tex)  
Patent infringement, Testifying expert for Supply Chain Management software, Manufacturing Automation, and Sales projection system software. Provide infringement and Invalidity rebuttal.
- *IslandIP Inc. v. Deutsche Bank Corporation*, 1:09-cv-04673-VM (S.D. NY)  
Patent infringement, Testifying expert for Financial Transaction, Omnibus account consolidation and settlement for Banks and Broker Dealers. Provide infringement and Invalidity rebuttal reports.
- *3M Future Africa (PTY) LTD v. The Standard Bank of South Africa LTD, MTN Group Limited and MTN Mobile Money SA (PTY) LTD*, Case #: Patent 2002/2337 (South African High Court)  
Patent infringement, testifying expert for Online Payments Security. Provide infringement, validity and trial support.
- *Cohen v. US*, 07-154-C (U.S. District Court of Federal Claims )  
Copyright infringement testifying expert for Cohen. US Government FEMA distributed copy righted documents without Cohen's knowledge or approval. Provide expert report, damages and deposition.
- *SFA v. 1-800-Flowers, et.al*, 6:2009-cv-00340-LED (E.D. Tex)
- *SFA v. Barnes & Noble, et.al*, 6:2011-cv-00399-LED (E.D. Tex)

Ivan Zatkovich - Consulting, Testimony & Publications

Page | 3

Ruiz Food Products, Inc.

Exhibit 1007

**e comp CONSULTANTS**

INFORMATION TECHNOLOGY & PATENT LITIGATION  
TELECOMMUNICATIONS • INTERNET • EFORENSICS

*1-800-Flowers.com, Inc., The Plow & Hearth, Inc., including D/B/A Wind & Weather, Inc.,  
The Popcorn Factory, Inc., Winetasting Network, Inc., The Children's Group, Inc.,  
Problem Solvers, Inc., Barnes & Noble, Inc., Barnesandnoble.com LLC, Blockbuster, Inc.,  
BUILD-A-BEAR WORKSHOP, INC., CDW Corporation  
GameStop, Corp., GameStop, Inc., GameStop.com, Inc., Gander Mountain Company,  
Overton's, Inc., J & R Electronics, Inc., Newegg, Inc., Newegg.com, Inc.  
Northern Tool & Equipment Company, Inc., Northern Tool and Equipment Catalog Co.  
Office Depot, Inc., Omaha Steaks International, Inc., OmahaSteaks.com, Inc.  
The Timberland Company, Tupperware Brands Corporation, Tupperware.com, Inc.*  
Patent infringement, for Computerized Sales Force Automation System. Testifying expert for joint  
invalidity (9 defendants) and non-infringement (5 defendants).

• *Bloom v. Intuitive*, 06 CV 6301 (S.D. NY)

Software contract dispute, testifying expert concerning Document Management and Publishing for  
Pharmaceuticals and Regulatory agencies. Comparison of product features and software reuse.

• *Dallal v. New York Times*, 1:2003-cv-10065 (S.D. NY) (settled 2008)

Testifying Expert, Deposition, for Web Copyright. Provided expertise in standard media publishing  
practices, content licensing, and web content customization.

• *LA Times v. Software AG*, 2:2007-cv-01289-SVW-JWJ (C.D. Cal.) (settled 2008)

Testifying Expert in Network & Database Software licensing dispute. Prepared expert report and  
deposition on software licensing practices.

• *Bear Creek Technologies v. Verizon Services Corp.*, 1:11-cv-00880-TSE -JFA (E.D. Virginia)(pending)  
Testifying Expert, provided infringement and invalidity of VoIP related patents.

• *Cequint v. Apple*, 1:2011-cv-01224 (Wilmington) (pending)

Testifying Expert. Performed code review of Cequint's City ID Software product to determine if  
and how they are practicing the key limitations of the patents-in-suit focused on Caller ID, CND  
Messages, City, State lookups, WAP interfaces, Database synchronicity (automatic update of  
database), Display of incoming caller information and Call Answer and set-up code.

• *Tel-tron Corporation v. Stanley Security Solutions d/b/a Stanley Healthcare Solutions*, 6:2011-cv-01448 (M.D. Florida)  
Testifying Expert regarding network systems for displaying data relating to emergency call systems.

• *Microsoft v 5R Processors, LTD. and Thomas Drake*, 3:12-cv-00263-slc, (W.D. Wisconsin)

Testifying Expert. Evaluate the Microsoft Windows Professional XP OEM Licensing Agreement  
and Microsoft Refurbished PC Licensing Guidelines and opine on 5R adherence.

• *Walker Digital, LLC v. Fandango, Inc., et al.*, 1:11-cv-00313-SLR (Delaware)

*Facebook Inc., Fandango, Inc., Expedia, Inc., Amazon.com, Inc., American Airlines, Inc., eBay Inc., and  
Zappos.com, Inc.*

Testifying Expert regarding e-commerce, shopping carts, e-marketing, and the promotion of  
financial products such as credit and debit cards for retail, business-to-business ("B2B"), and  
financial industries. Provided Infringement (Amazon, Expedia, Zappos) Reports and Invalidity  
Rebuttal Report.

• *Triakard v. P.S.K.W. & Associates*, 3:11-cv-05693-FLW-TJB (New Jersey)

**Ivan Zatkovich - Consulting, Testimony & Publications**

Page | 4

**e**compCONSULTANTS

INFORMATION TECHNOLOGY & PATENT LITIGATION  
TELECOMMUNICATIONS • INTERNET • EFORENSICS

Testifying Expert for patent re-exam concerning eCommerce technology based on a method of dispensing, tracking, and managing pharmaceutical products by communicatively linking prescribers and pharmacies to a central computing system

- *Catalina Marketing Corporation v. Coupons, Inc.*, JAMS Reference No. 11000654507 (San Francisco)  
Testifying Expert to analyze the following Coupons systems, Microsite System & Brandcaster™ System and determine if either system is an "Infringing Capable System". Provided Expert Report and Mediation Trial support.
- *AKH Co., Inc. v. The Reinalt-Thomas Corp. & Southern California Discount Tire Co., Inc.*, SACV10-1626 CJC  
Testifying Expert regarding trademark infringement & cybersquatting. Provided Expert Report and deposition.
- *Soverain v. Euromarket Design*, et al. 6:12-cv-00145-LED (E.D. Texas) (pending)  
Testifying Expert regarding e-commerce systems/online shopping carts technology.
- *e-LYNXX Corporation v. InnerWorkings, Inc., et al.* 1:10-CV-2535 (M.D. PA)  
*InnerWorkings, Standard Register, Cirqit.com and R.R. Donnelley & Sons Co.*  
Testifying Expert regarding supply chain, custom print jobs, matching job requirements to vendors technology. Provided Infringement, Invalidity and Non Infringement Rebuttal Reports and deposition.
- *Joao Bock Transaction Services v. USAmeribank, et al.*, 8:11-cv-00887-MSS-TGW (Tampa)  
*USAmeribank, Everbank and BankFirst*  
Testifying Expert regarding secure transactions on electronic financial accounts.
- *Lodsys v. Brother Intl Group et al.*, 2:11-cv-90(JRG) (E.D. Texas)  
*Brother Intl Corp, Canon U.S.A., Inc., Hewlett-Packard Company, Hulu, LLC, Lenovo (United States) Inc. Lexmark International, Inc., Motorola Mobility, Inc., Novell, Inc., Samsung Electronics Co., LTD., Samsung Electronics America, Inc., Samsung Telecommunications America, LLC, Trend Micro Incorporated*  
Testifying Expert regarding interactive media enabling CRM technology. Provided Invalidity Rebuttal Reports and deposition testimony.

- 
- *Progressive v. State Farm, et al.* CBM2012-00003, CBM2013-00004  
*State Farm Insurance, Hartford Insurance, Liberty Mutual Insurance, Safeco Insurance, Ohio Casualty Insurance, Open Seas Solutions, Octo Telematics*  
Testifying Expert regarding e-Commerce and vehicle telematics systems. Provided Patent Re-exam Declarations.
  - *Black Hills Media, LLC v. Samsung, et al.* INV# 337-TA-882 [ITC case] (pending)  
*Samsung, LG, Panasonic, Toshiba, Sharp*  
Testifying Expert regarding Google Latitude running on smartphones and smart phones running software which can direct the streaming of content between, for example, a laptop and a TV or Blu-ray player. Providing device analysis and code review, Infringement Reports and Rebuttal Reports.
  - *Rembrandt Social Media, LP v. Facebook, Inc. and ADDTHIS, Inc.*, 1:13cv158 (TSE/TRJ) (Virginia)  
Testifying Expert regarding social media user content and 3<sup>rd</sup> party interaction -the diary page and "Like" feature. Provided Non Infringement Report and deposition.

Ivan Zatkovich- Consulting, Testimony & Publications  
Page | 5



**e**compCONSULTANTS

INFORMATION TECHNOLOGY & PATENT LITIGATION  
TELECOMMUNICATIONS • INTERNET • EFORENSICS

- *Indacon, Inc v. Facebook, Inc* 5:130cv966-OLG (TX)  
Testifying Expert regarding automated creation of user-defined hyperlinks in a database. Provided Non Infringement Report and deposition.
- *GeoTag, Inc v. Frontier Communications Corp. et al* 2:10-cv-00265 (TX) [Multiple cases]  
*Macy's, Genesco, AGCO Corp., The Rockport Company, LLC., Hennes & Mauritz LP (H&M), Gander Mountain Company, Godiva Chocolatier, DSW, National Interlock Systems*  
Testifying Expert regarding e-Commerce, Geo location, store locator based technology. Provided Non Infringement Reports for multiple defendants.
- *CareerFairs.com v. United Business Media, LLC, et al.* 11-20329-CIV-KING (S.D. Florida)  
Testifying Expert regarding videoconferencing, virtual career fairs technology.
- *Transauction LLC v. eBay Patent 7343339* 3:2009cv03705 (N.D. CA)  
Expert regarding computerized electronic auction payment systems.
- *Ameranth v. Six Continents Hotels*, 09-CV3819 (GA)  
Testifying Expert regarding Internet Advertising & Website Technology. Expert Report and deposition.
- *Carolina Power & Light Company v. Aspect Software* 5:08-cv-00449-BO (E.D. NC)  
Testifying Expert in telecommunications technology.
- *Dominion v. Aspect Software*, 3:08-cv-00737-REP (Virginia)  
Testifying Expert in telecommunications and IVR call processing. Provided expert declaration and testimony.
- *ComplementSoft v. SAS Institute*, 12-C-7372 (N.D. IL)  
Expert regarding software development tools, database manipulation, SAS programming.
- *Moricz v. Google*, 10-cv-01240-RSL (Seattle)  
Expert regarding use of deep search methodology. Claim Construction support.
- *Media Rights Technologies v. Capital One, et al.*, 1:13cv476-AJT/TRJ (Virginia)  
Expert regarding secure internet Banking System technology USPatent# 7316033.
- *CertusView v. S&N*, 2:13-cv-346 (MSD) (LRL) (Virginia)  
Testifying Expert regarding geolocation. U.S. PATENT # 8,265,344, 8,290,204, 8,340,359, 8,407,001, AND 8,532,341
- *Bright Edge v SearchMetrics*, 3:14cv-01009 (San Francisco)  
Testifying Expert regarding search optimization, USPatent# 8478700, USPatent# 8478746.
- *Black Hills Media, LLC v. Sonos*, 2:14-CV-00486 SJO (PJWx) (California Western Division)  
Testifying Expert regarding delivery of stored and streaming audio content over wide-area and local area networks. U.S. PATENT # 6,757,517, 7,236,739, 7,742,740 and 6,826,283
- *Yamaha Corp of America v. Black Hills Media, LLC*, IPR2013-00593, IPR2013-00594, (PTO)  
Testifying Expert regarding software which can direct the streaming of content between devices, for example, a laptop and a TV or Blu-ray player. Providing Inter Partes Review Declaration Reports. U.S. PATENT # 8,050,652, 8,045,952

Ivan Zatkovich - Consulting, Testimony & Publications

Page | 6

Ruiz Food Products, Inc.

Exhibit 1007

**e**compCONSULTANTS

INFORMATION TECHNOLOGY & PATENT LITIGATION  
TELECOMMUNICATIONS • INTERNET • EFORENSICS

- *Samsung Electronics, et al. v. Black Hills Media, LLC*, IPR2014-00737, IPR2015-00334, IPR2014-00740, IPR2015-00340, IPR2014-00735 (PTO)

Testifying Expert regarding software which can direct the streaming of content between devices, for example, a laptop and a TV or Blu-ray player. Providing Inter Partes Review Declaration Reports. U.S. PATENT # 8,050,652, 8,045,952, 6,618,593

- *GT Nexus v Intra, Inc.*, 4:11-cv-02145-SBA (California Northern Division)

Testifying Expert regarding networks & systems used for logistics management. Provided Declaration for CBM petitions. U.S. Patent No. 7,761,387, 7,752,142, 7,827,119, 7,756,794

- *MyKey Technology, Inc. v. Intelligent Computer Solutions, Inc.*, 2:13-ml-02461-AG (PLAx) MDL NO. 2461 (Central California Southern Division)

Testifying Expert regarding hard drives and other mass storage devices, how to access "hidden" storage and cleaning a disk. Provided Validity Rebuttal and MSJ Declaration. U.S. Patent No. 6,813,682, 7,228,379

- *Biosignia Inc. v. Life Line Systems*

- *AT&T v Infoage, Sago Data Centers*

- *Intellectual Ventures v US Sprint*

4

## TechnoCom White Paper

# Location-enhanced Call Center and IVR Services, Technical Insights About Your Calling Customer's Location, 2009

## Location-enhanced Call Center and IVR Services *Technical Insights About Your Calling Customer's Location*

---

### Executive Summary

Enterprise operations can save money and increase profits by enhancing service to their incoming callers by automatically locating the caller. This is currently being done for wireline callers using the ubiquitous caller ID, but has only recently become available for wireless callers. There are important differences between street address derived from wireline caller ID and the information available about the location of a mobile caller. This information can be hugely valuable, such as for a call from a person broken down on a long stretch of highway. In fact, in this case there is simply no address that could be provided. At the same time, limitations of wireless location technologies make it difficult to identify that a call is coming from a specific apartment number. This white paper provides background to readers not completely familiar with wireless location technologies, their relative accuracies, and the implications to caller assistance and other contact center solutions.

---

*Why is more needed?  
Simply put – because  
phones and callers are no  
longer fixed to geography  
and mobile phones in the  
U.S. now outnumber  
wireline phones!*

---

### Introduction

Enterprises and individuals have become accustomed to knowing “who” is calling by virtue of ubiquitous caller ID that accompanies wireline and wireless phone calls. Similar insight about “where” a caller is located is also now available for call center and IVR applications. This information can be used to improve dispatched services, automate call routing to the nearest service point, or help the caller “find the nearest”. Any dialog with the customer that includes “Where are you?” can find cost savings, operating efficiencies and enhanced customer service by automating the answer to this question. Some caller location automation solutions have used telephone area code and prefix effectively for years. Others ask the user for their location with prompts such as, “Please enter your zip code.”

Why is more needed? Simply put – because phones and callers are no longer fixed to geography and mobile phones in the U.S. now outnumber wireline phones! For mobile telephones, fixed addresses are only relevant for billing purposes. When asked, mobile users often complain, “I don’t know the zip code here.” Telephony now encompasses far more than traditional plain old telephone service (POTS) and systems that rely on fixed line logic fail to serve an ever growing percentage of callers.

Across the range of available telephony services, the technologies available to determine caller location range from very accurate, as with the registered address of a home phone or the global positioning system (GPS) location of a mobile caller; to less precise zip code or prefix-based location that might yield the caller's neighborhood; or simply an unknown location. Optimizing the caller experience requires IVR logic and operator-assisted work flows designed with a thorough understanding of the range and availability of location information. A good design that leverages the value from caller location and handles the exceptions effectively can yield substantial enterprise and customer benefits. The sections that follow describe in more detail the benefits of mobile caller location as well as some practical considerations for its effective application.

### Location Enhanced Call Center and IVR Overview

The concept of the "location enhanced" call center and IVR is simple – customer services use the knowledge of caller's location to improve the services delivered, resulting in a faster, more economical, and better customer experience. Examples include:

- Helping callers even when they don't know where they are to reduce costly dispatch mistakes and to substantially reduce the costs of operator time by reducing service call duration.
- Automatically routing calls made to a central number to the local point of sale to leverage the personal service from local stores and franchises to close sales.
- Reducing the hassle and time in answering the question "Where are you?" to realize operator cost savings and improve customer satisfaction.

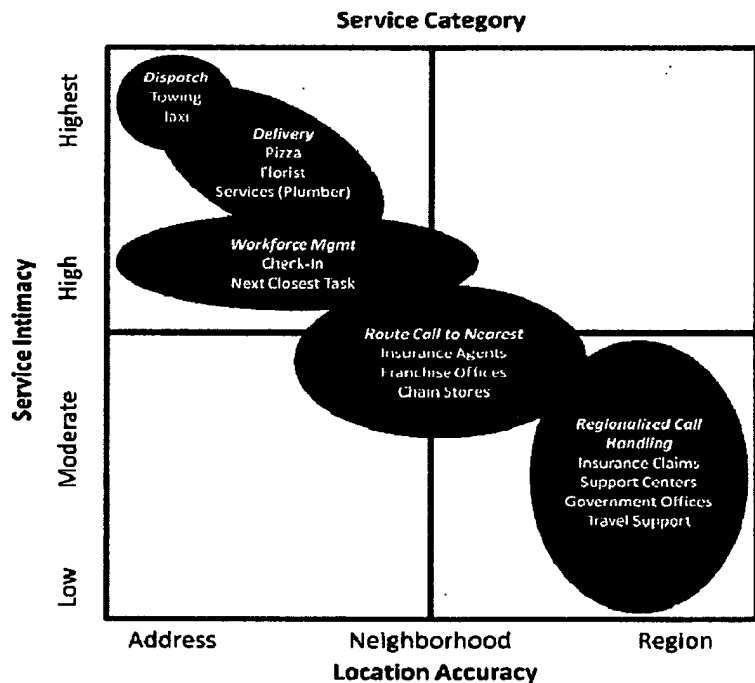

Given the range of location technologies in use, caller location accuracy can vary from as precise as a few meters to as coarse as a few thousand meters. As illustrated in the figure above, the corresponding benefit to call centers and IVR applications can therefore range from being very substantial to quite limited depending on the needs of particular location enhanced services.

## Source of Location According to Call Origin

The call center or IVR system can obtain the caller's location through one of three mechanisms:

1. **Manual Entry by Caller (Wireline or Wireless)** – someone, either the caller or the operator, provides all the details of the caller's location. This may be semi-automated at the IVR with speech-to-text, menu selection, or a fully manual process of the caller speaking the address to the operator to in turn be typed into the service application. In all cases, the caller engages in a "manual" process of providing his/her location.
2. **Database Look-Up** – the caller location is accessed by using the caller ID or a caller-provided user ID from an enterprise, telephone carrier, or other database. Database lookup requires a source of stored locations for fixed callers, so this method is not applicable to the mobile caller.
3. **Computed Wireless Location**– geometric computations of caller location using wireless signal measurements such as those received from GPS satellites or wireless network base stations. In some cases the resulting location may be limited to a predetermined area such as that defined by the signal coverage of a cell site or sector.

### *Manual Entry – Wireline or Wireless*

Manual entry of caller location can be very precise, since the caller can state any location they desire, where they are now ("I'm calling from home") or an address required for service elsewhere ("My car is in the shop located at ..."). However, address capture can be inaccurate if mistakes are made by the caller, operator or speech-to-text system, or if the caller simply doesn't know his/her address. Sometimes no address is available, such as on a road between towns.

**Speak Your Address:** Today's most common user input for a precise location is answering the question "Where are you?" to a live operator or speech recognition system and providing a full street address, city, and state. Errors in spelling, data entry, or simply misunderstanding may introduce errors. The process can be time consuming and may not be applicable to the mobile user.

**Enter Your ZIP Code:** A commonly used method of entry on web pages and voice input is asking for the caller's zip code to ascertain coarse location such as city, town or neighborhood. This can be less time consuming and less susceptible to entry errors than manually entering or speaking a full address and can be very useful for calls originating from one's home or office. However, this is often found to be useless and aggravating to the mobile or traveling user who doesn't know the zip code from where they are calling.

### *Database Look-Up*

There are a number of static database sources that can be used to look up the caller's location based on an index or key, typically these use the caller ID (phone number) of the caller. Some of these databases create a one-to-one relationship between the ID and a location, such as the address corresponding to a

fixed phone line. Others have a many-to-one relationship with multiple entries for home, work, school, etc., and the user may be asked to indicate which one is applicable at the time of a call. Still others are designed for the mobile environment, identifying the fixed location of each cell site in a wireless network and associating a mobile caller's current location with the location of the site in use for communication.

**Caller ID Key:** Fixed line 911 is an extremely effective, accurate, life saving example of identifying caller location based on the caller's phone number delivered by the telephone network, known as "caller ID". When a caller dials 911 from a landline, the service address is retrieved from a database to be presented to the emergency services operator. The 911 industry makes a substantial investment in maintaining the integrity of the address database. However, this 911 database is not available for commercial use, due to privacy constraints. Commercial databases based on telephone company records are a source of caller addresses, however unlisted phone numbers, virtual numbers, and lagging record updates can result in unknown or inaccurate results. If an enterprise has its own CRM database that includes wireline phone numbers of its members or customers, it can be a good source of accurate caller location using the caller ID key. However, this is only true if the call originates from the phone number stored in the customer database.

**User ID Key:** Some enterprise applications may use a location-specific code as a key to access a stored location record. Either a fixed location caller or a mobile caller manually enters a defined key for their location that maps to a predefined list, such as in a mobile worker application visiting a pre-defined customer site. The method can be efficient, however the caller location is only applicable to trusted uses, since the validity cannot automatically be validated.

**VoIP Key:** IP routed calls may provide router and access point identifiers that can be used to access caller location from databases that have been compiled from various sources of geocoded IP addresses, including some open sources. The accuracy of such information can be very good, or quite poor and may include triangulation (described below for cell towers) to refine a location using signal measurements from multiple Wi-Fi access points. This is a technology that is still evolving as a commercial source of accurate location information.

**Cellular Tower and Sector:** Mobile network operators survey and record the geographic locations of their cell site towers and create radio network plans that model the radiated signal around those towers ("coverage"), or cells, which are often segmented into pie-shaped wedges called sectors. The geographic center point of each cell-sector is determined by the operator and stored in a database. These "cell" and "sector" centroid entries are uniquely identified in the network operator's databases and can be used to estimate a mobile caller's location based on the cell-sector being used for communication by the caller's mobile telephone. This method of location is commonly referred to as a "cell ID" or "cell-sector" location. The location provided is a latitude/longitude approximating the caller's location as accurately as a city block in dense, urban environments, to as coarse as many miles in rural areas.

## Computed Wireless Location

Computed locations of varying accuracy can be determined by measuring and processing signals received by mobile telephones from global positioning system (GPS) satellites or cell towers in wireless networks. The ability to locate mobile phones became common in the U.S. in the late 1990's after being mandated by the U.S. government for enhanced wireless 911 services. The Federal Communication Commission (FCC) required all U.S. wireless service providers to support wireline "equivalent" caller location for public safety purposes.

The FCC's Enhanced 911 (E911) rules established accuracy standards for emergency caller location that have driven the location technologies deployed by wireless operators such as AT&T, Verizon, Sprint and T-Mobile. The FCC accuracy standards, adopted in 1996 and 1999, are shown in the adjacent table.

<b>FCC E911 Location Accuracy Requirements</b>		
	67% of calls	95% of calls
Handset-based solutions (e.g., GPS)	≤ 50 meters	≤ 150 meters
Network based solutions (e.g., triangulation)	≤ 100 meters	≤ 300 meters

**GPS:** GPS technology is ubiquitous in everything from cell phones to vehicle navigation systems to pet locating collars and more. In the U.S. and Canada, virtually 100% of CDMA phones are equipped with GPS technology – that's more than 150 million such devices! CDMA phones and many smart phone models in use by all wireless carriers, GSM/UMTS and CDMA, provide GPS location capabilities using highly accurate chipsets from manufacturers like Broadcom, Infineon, SiRF, QUALCOMM, and others. GPS typically provides the latitude/longitude (lat/lon) of a caller's location within accuracies ranging from just a few meters to dozens of meters.

**Tower Triangulation:** Mobile phones continuously monitor signals received from nearby cell sites to select the best serving cell and to facilitate hand-off from one cell to another as the user moves about. Location servers in the carrier networks process information from multiple cell towers, combined with cell phone signal measurements derived from timing, angle, and/or signal strength. These servers determine mobile phone location using any of a variety of triangulation and trilateration methods known by acronyms such as TDOA, AOA, AFLT, EFLT, RTT, RFS, E-CID, and more. These geolocation methods provide an estimate of where a caller is located that is typically accurate to within a hundred to a few hundred meters.

**Estimate of the Computational Error:** Unlike database look-up of caller location information, the accuracy of a computed location can vary depending upon the accuracy of the measurements used to derive the result, the geometry of the satellites or cell towers, and signal propagation anomalies in the vicinity of the mobile phone. The various computational methods used to determine the caller's location also provide an estimate of the error associated with each resulting location.

Computed location lat/lon values are usually accompanied by a value called Uncertainty that is an estimate of the location error in meters. This error estimate, or Uncertainty, is a statistical measure representing the distance between the computed location and the caller's actual location with a certain



degree of Confidence, typically 67% or 90% depending on the technology used. Therefore, just as a database lookup of a caller's location can be wrong due to data entry or transcription errors, a computed location may be farther from the caller's actual location than the error suggested by the Uncertainty with a probability typically of about 10% to 33% (100% minus the Confidence). The adjacent figure illustrates the typical levels of location accuracy achieved by the various location methods described above.

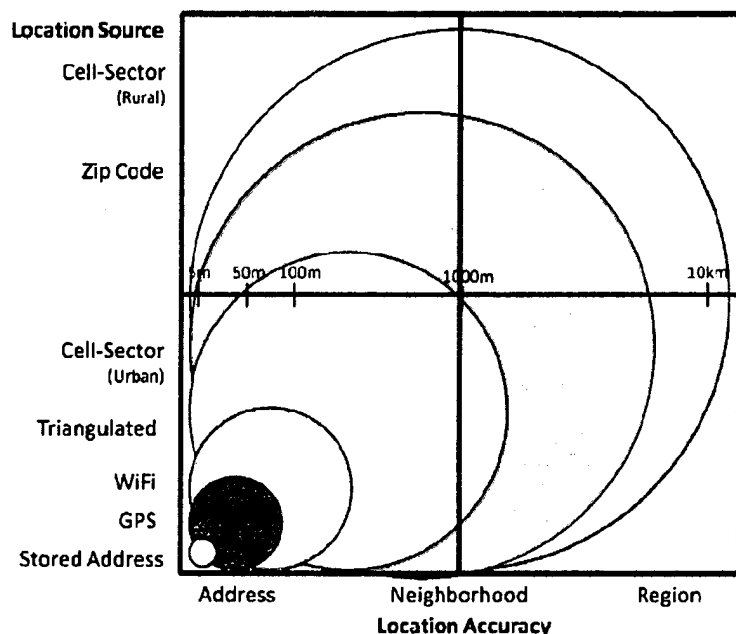

### Time to Location Fix

Another factor in obtaining caller location is the response time, or as it is commonly called “time to fix” or “time to first fix”. This is time required to obtain the caller’s location when requested from the wireless network’s location server. The time can vary from “instant” (less than a second) to tens of seconds, depending on the location technology used and other factors such as wireless network congestion. Even “instant” database lookup can take time such as the “Please wait while I look up your address” response from customer service operators.

Depending on the method, three factors can contribute to the time required to obtain the caller location:

1. Time for the caller to verbally state their location
2. Database access time for the system to look up the caller location
3. Time required to gather the signal measurements and compute the location

Accuracy and time to fix are most often a trade off. A caller stated address may be highly accurate, but require the longest amount of time to collect. A GPS location fix that can be equally accurate requires capture of satellite signal measurements, transmission of measurements across the wireless networks and location computation which can require from 10 to 30 seconds. And lastly, the database lookup generally has the capability of being “instant”, even sub-second, but may provide only a coarse location for wireless callers.

## **Mobile Caller Location Privacy Considerations**

Beyond the performance and operational aspects of mobile caller location technology, this new capability brings along its own set of rules around consumer privacy and data security. Today, the personal data of mobile callers, including location, are carefully protected by wireless carrier policies and technology. The work of trade organizations is helping to foster the uniform application of these policies. Best practices and guidelines have been advocated by wireless trade groups such as the Cellular Telecommunications Industry Association (CTIA) and the Mobile Marketing Association (MMA). The current rules for mobile telephone location privacy are based on two key precepts: the caller's permission must be explicitly requested and granted before his/her location may be obtained; and the caller must be clearly informed of the intended use of the location information. The caller's consent may be obtained temporarily for a one-time use or persistently for recurring uses. In the latter case, the caller must be periodically reminded that he/she has granted consent to be located and informed of the means by which he/she may revoke their consent.

## **Conclusions and Lessons**

The principle lessons to be applied by call center IT and IVR solution designers is that the answer to "Where are you?" can come from a variety of sources and be provided with varying degrees of accuracy. Traditional methods that simply ask the caller result in a cost to the call center and to the caller in time, money, and convenience. This "manual" method also suffers from the inability to help locate a caller that does not know their location, communicates it unclearly, or is incorrectly recorded by a customer service agent or speech-to-text system. For enterprise applications and services that can be enhanced by locating the caller, doing so in a way that assures the greatest accuracy and minimizes the time required to obtain the location information will deliver the maximum benefit in terms of operating efficiencies, customer satisfaction and service costs. New technologies available from wireless operators to solve the challenges of accurate and timely mobile caller location are now available. Applying these technologies properly to call center and IVR applications can deliver benefits that have not traditionally been possible to date.

5

Thomas

U.S. Patent No. 8,301,158



US008301158B1

(12) **United States Patent**  
Thomas

(10) **Patent No.:** US 8,301,158 B1  
(45) **Date of Patent:** \*Oct. 30, 2012

- (54) **METHOD AND SYSTEM FOR LOCATION TRACKING**
- (75) **Inventor:** C. Douglass Thomas, Campbell, CA (US)
- (73) **Assignee:** IpVenture, Inc., Los Altos, CA (US)
- (\* ) **Notice:** Subject to any disclaimer, the term of this patent is extended or adjusted under 35 U.S.C. 154(b) by 305 days.  
  
This patent is subject to a terminal disclaimer.

5,512,902 A	4/1996	Guthrie et al.
5,515,858 A	5/1996	Myllymaki
5,528,247 A	6/1996	Nonami
5,528,518 A	6/1996	Bradshaw et al.
5,532,690 A	7/1996	Hortel
5,539,748 A	7/1996	Raith
5,541,845 A	7/1996	Klein
5,550,551 A	8/1996	Alesio
5,568,119 A	10/1996	Schipper et al.
5,570,412 A	10/1996	LeBlanc
5,576,716 A	11/1996	Sadler
5,592,173 A	1/1997	Lau et al.
5,598,460 A	1/1997	Tendler
5,604,708 A	2/1997	Helms et al.
5,623,260 A	4/1997	Jones
5,623,418 A	4/1997	Rostoker

(Continued)

(21) **Appl. No.:** 12/150,126

(22) **Filed:** Apr. 26, 2008

**Related U.S. Application Data**

- (63) Continuation of application No. 09/797,517, filed on Feb. 28, 2001, now Pat. No. 7,366,522.
- (60) Provisional application No. 60/185,480, filed on Feb. 28, 2000.

- (51) **Int. Cl.**  
H04W 24/00 (2009.01)
- (52) **U.S. Cl.** ..... 455/456.1; 455/404.2; 455/414.2; 455/440; 340/539.13
- (58) **Field of Classification Search** ..... 455/456.1, 455/404.2, 414.2, 440; 340/539.13, 825.49, 340/988; 342/357.1, 457, 357.01; 701/213  
See application file for complete search history.

(56) **References Cited**

**U.S. PATENT DOCUMENTS**

5,347,274 A	9/1994	Hassett
5,389,934 A	2/1995	Kass
5,400,020 A	3/1995	Jones et al.
5,461,365 A	10/1995	Schlager et al.
5,491,486 A	2/1996	Welles, II et al.

**FOREIGN PATENT DOCUMENTS**

EP 0 874 529 A2 10/1998

(Continued)

**OTHER PUBLICATIONS**

U.S. Appl. No. 12/150,203, filed Apr. 2008, Thomas.\*

(Continued)

*Primary Examiner* — Nghi H Ly

(57) **ABSTRACT**

Techniques for location tracking, location utilization, and dissemination and management of location information are disclosed. As a location monitoring system, one embodiment includes at least a plurality of mobile computing devices supported by a wireless network, and a web server coupled to a wired network (e.g., the Internet) that couples to the wireless network. Each of the mobile computing devices are associated with and proximate to an object whose location is being monitored. The web server stores the locations of each of the mobile computing devices or the objects proximate thereto, and enables only authorized users to obtain access the locations via the wired network.

**68 Claims, 8 Drawing Sheets**

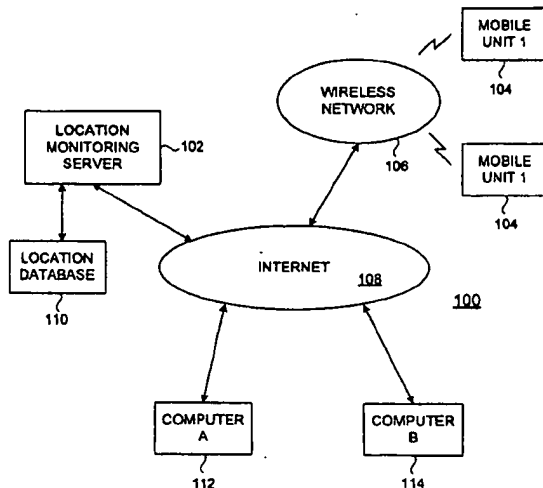

U.S. PATENT DOCUMENTS

5,629,678 A	5/1997	Gargano et al.	6,198,390 B1	3/2001	Schlager et al.
5,633,874 A	5/1997	Diachina et al.	6,198,431 B1	3/2001	Gibson
5,650,770 A	7/1997	Schlager et al.	6,198,930 B1	3/2001	Schipper
5,652,570 A	7/1997	Lepkofker	6,199,045 B1	3/2001	Gringer et al.
5,673,692 A	10/1997	Schulze et al.	6,212,133 B1	4/2001	McCoy et al.
5,686,888 A	11/1997	Welles, II et al.	6,226,622 B1	5/2001	Dabbiere
5,710,551 A	1/1998	Ridgeway	6,231,519 B1	5/2001	Blants et al.
5,712,619 A	1/1998	Simkin	6,232,916 B1	5/2001	Grillo et al.
5,731,757 A	3/1998	Layson et al.	6,236,358 B1	5/2001	Durst et al.
5,731,788 A	3/1998	Recds	6,238,337 B1	5/2001	Kambhatla et al.
5,742,233 A	4/1998	Hoffman et al.	6,243,039 B1	6/2001	Elliot
5,751,245 A	5/1998	Janky et al.	6,243,660 B1	6/2001	Hsu et al.
5,771,001 A	6/1998	Cobb	6,246,376 B1	6/2001	Bork et al.
5,771,455 A	6/1998	Kennedy, III et al.	6,252,543 B1	6/2001	Camp
5,774,876 A	6/1998	Woolley et al.	6,263,280 B1	7/2001	Stingone, Jr.
5,797,091 A	8/1998	Clise et al.	6,278,936 B1	8/2001	Jones
5,808,565 A	9/1998	Matta et al.	6,281,797 B1	8/2001	Forster
RE35,920 E	10/1998	Sorden et al.	6,282,362 B1	8/2001	Murphy et al.
5,825,283 A	10/1998	Camhi	6,282,495 B1	8/2001	Kirkhart et al.
5,826,195 A	10/1998	Westerlage et al.	6,292,687 B1	9/2001	Lowell et al.
5,835,907 A	11/1998	Newman	6,298,306 B1	10/2001	Suarez et al.
5,841,352 A	11/1998	Prakash	6,300,875 B1	10/2001	Schafer
5,844,862 A	12/1998	Cocatre-Zilgien	6,302,844 B1	10/2001	Walker et al.
5,850,196 A	12/1998	Mowers	6,304,467 B1	10/2001	Nebriagic
5,861,841 A	1/1999	Gildea et al.	6,314,308 B1	11/2001	Sheynblat et al.
5,883,594 A	3/1999	Lau	6,317,049 B1	11/2001	Toubia et al.
5,889,770 A	3/1999	Jokiaho et al.	6,323,807 B1	11/2001	Golding et al.
5,892,454 A	4/1999	Schipper et al.	6,324,213 B1	11/2001	Harrison
5,905,461 A	5/1999	Neher	6,327,533 B1	12/2001	Chou
5,913,078 A	6/1999	Kimura et al.	6,331,817 B1	12/2001	Goldberg
5,917,433 A	6/1999	Keillor et al.	6,339,397 B1	1/2002	Baker
5,918,180 A	6/1999	Dimino	6,340,928 B1	1/2002	McCurdy
5,938,721 A	8/1999	Dussell et al.	6,342,847 B1	1/2002	Archuleta et al.
5,948,040 A	9/1999	DeLorme et al.	6,349,257 B1	2/2002	Liu et al.
5,948,043 A	9/1999	Mathis	6,353,390 B1	3/2002	Beri et al.
5,959,575 A	9/1999	Abbott	6,353,798 B1	3/2002	Green et al.
5,959,577 A	9/1999	Fan et al.	6,356,841 B1	3/2002	Hamrick et al.
5,963,130 A	10/1999	Schlager et al.	6,362,778 B2	3/2002	Neher
5,970,388 A	10/1999	Will	6,363,254 B1	3/2002	Jones et al.
5,982,285 A	11/1999	Bueche et al.	6,363,323 B1	3/2002	Jones
5,982,807 A	11/1999	Snell	6,373,430 B1	4/2002	Beason et al.
5,983,108 A	11/1999	Kennedy, III et al.	6,377,810 B1	4/2002	Geiger et al.
5,991,690 A *	11/1999	Murphy ..... 701/211	6,388,612 B1	5/2002	Neher
5,995,849 A	11/1999	Williams et al.	6,393,346 B1	5/2002	Keith et al.
6,002,363 A	12/1999	Krasner	6,404,352 B1	6/2002	Ichikawa et al.
6,002,982 A	12/1999	Fry	6,407,698 B1	6/2002	Ayed
6,009,319 A	12/1999	Khullar et al.	6,411,892 B1	6/2002	Van Diggelen
6,013,007 A	1/2000	Root et al.	6,411,899 B2	6/2002	Dussell et al.
6,014,080 A	1/2000	Layson, Jr.	6,421,538 B1	7/2002	Byrne
6,014,090 A	1/2000	Rosen et al.	6,426,719 B1	7/2002	Nagareda et al.
6,023,241 A	2/2000	Clapper	6,427,120 B1	7/2002	Garin et al.
6,031,496 A	2/2000	Kuittinen	6,430,602 B1	8/2002	Kay et al.
6,032,051 A	2/2000	Hall et al.	6,433,732 B1	8/2002	Dutta et al.
6,034,622 A	3/2000	Levine	6,434,396 B1	8/2002	Rune
6,054,928 A	4/2000	Lemelson	6,441,778 B1	8/2002	Durst et al.
6,064,336 A	5/2000	Krasner	6,442,380 B1	8/2002	Mohindra
6,067,018 A	5/2000	Skelton et al.	6,442,391 B1	8/2002	Johansson et al.
6,067,044 A	5/2000	Whelan et al.	6,443,890 B1	9/2002	Schulze et al.
6,072,396 A	6/2000	Gaukel	6,445,937 B1	9/2002	daSilva
6,078,290 A	6/2000	McBurney et al.	6,453,237 B1	9/2002	Fuchs et al.
6,083,248 A	7/2000	Thompson	6,463,272 B1	10/2002	Wallace et al.
6,083,353 A	7/2000	Alexander	6,466,821 B1	10/2002	Pianca et al.
6,094,168 A	7/2000	Duffert-Smith et al.	6,469,639 B2	10/2002	Tanenhaus et al.
6,100,806 A	8/2000	Gaukel	6,471,087 B1	10/2002	Shusterman
6,101,710 A	8/2000	Selinger	6,478,736 B1	11/2002	Mault
6,111,540 A	8/2000	Krasner	6,496,775 B2	12/2002	McDonald, Jr. et al.
6,115,595 A	9/2000	Rodal et al.	6,505,048 B1	1/2003	Moles et al.
6,121,921 A	9/2000	Ishigaki	6,505,049 B1	1/2003	Dorenbosch
6,131,067 A	10/2000	Girerd et al.	6,513,532 B2	2/2003	Mault et al.
6,140,863 A	10/2000	Fujisawa	6,522,871 B1	2/2003	Patrick et al.
6,141,570 A	10/2000	O'Neill, Jr. et al.	6,522,889 B1	2/2003	Aarnio
6,144,303 A	11/2000	Federman	6,529,164 B1	3/2003	Carter
6,148,280 A	11/2000	Kramer	6,544,193 B2	4/2003	Abreu
6,154,422 A	11/2000	Shinkawa et al.	6,552,652 B2	4/2003	Beken
6,163,696 A	12/2000	Bi et al.	6,553,336 B1	4/2003	Johnson et al.
6,171,264 B1	1/2001	Bader	6,559,620 B2	5/2003	Zhou et al.
6,172,640 B1	1/2001	Durst et al.	6,569,094 B2	5/2003	Suzuki et al.
6,175,616 B1	1/2001	Light et al.	6,579,231 B1	6/2003	Phipps
			6,579,844 B1	6/2003	Morrison et al.

6,625,437 B1\* 9/2003 Jampolsky et al. .... 455/405  
 6,630,885 B2 10/2003 Hardman et al.  
 6,640,085 B1 10/2003 Chatzipetros et al.  
 6,650,907 B1 11/2003 Kampserschroer et al.  
 6,661,372 B1 12/2003 Girerd et al.  
 6,665,534 B1 12/2003 Conklin et al.  
 6,679,071 B1 1/2004 Storey et al.  
 6,696,982 B2 2/2004 Yoshioka et al.  
 6,714,791 B2 3/2004 Friedman  
 6,721,542 B1 4/2004 Anttila et al.  
 6,741,927 B2 5/2004 Jones  
 6,747,675 B1 6/2004 Abbott et al.  
 6,748,318 B1 6/2004 Jones  
 6,788,766 B2 9/2004 Logan  
 6,801,853 B2 10/2004 Workman  
 6,804,606 B2 10/2004 Jones  
 6,847,892 B2 1/2005 Zhou et al.  
 6,856,804 B1 2/2005 Ciotta  
 6,865,385 B1 3/2005 Kohda et al.  
 6,937,900 B1 8/2005 Pianca et al.  
 6,952,645 B1 10/2005 Jones  
 6,975,941 B1 12/2005 Lau et al.  
 6,980,826 B2 12/2005 Yamaguchi  
 7,010,144 B1 3/2006 Davis et al.  
 7,071,842 B1 7/2006 Brady, Jr.  
 7,085,253 B2 8/2006 Yang  
 7,110,773 B1 9/2006 Wallace et al.  
 7,136,832 B2 11/2006 Li et al.  
 7,187,278 B2 3/2007 Biffar  
 7,212,829 B1 5/2007 Lau et al.  
 7,218,938 B1 5/2007 Lau et al.  
 7,253,731 B2 8/2007 Joao  
 7,321,774 B1 1/2008 Lau et al.  
 7,366,522 B2\* 4/2008 Thomas ..... 455/456.1  
 7,403,972 B1 7/2008 Lau et al.  
 7,539,557 B2 5/2009 Yamauchi  
 7,809,377 B1 10/2010 Lau et al.  
 7,905,832 B1 3/2011 Lau et al.  
 7,953,809 B2 5/2011 Lau et al.  
 8,176,135 B2 5/2012 Lau et al.  
 2001/0006891 A1 7/2001 Cho  
 2001/0020204 A1 9/2001 Runyon et al.  
 2001/0027378 A1 10/2001 Tennison et al.  
 2001/0028304 A1 10/2001 l'Anson et al.  
 2001/0044299 A1 11/2001 Sandegren  
 2001/0044332 A1 11/2001 Yamada et al.  
 2001/0052849 A1 12/2001 Jones, Jr.  
 2002/0000930 A1 1/2002 Crowson et al.  
 2002/0016173 A1 2/2002 Hunzinger  
 2002/0027507 A1 3/2002 Yarin et al.  
 2002/0036593 A1 3/2002 Ying  
 2002/0038182 A1 3/2002 Wong et al.  
 2002/0049742 A1 4/2002 Chan et al.  
 2002/0050945 A1 5/2002 Tsukishima et al.  
 2002/0057192 A1 5/2002 Eagleson et al.  
 2002/0063622 A1 5/2002 Armstrong et al.  
 2002/0071677 A1 6/2002 Sumanaweera  
 2002/0077080 A1 6/2002 Greene  
 2002/0087260 A1 7/2002 Hancock et al.  
 2002/0087619 A1 7/2002 Tripathi  
 2002/0094067 A1 7/2002 August  
 2002/0111171 A1 8/2002 Boesch et al.  
 2002/0111819 A1 8/2002 Li et al.  
 2002/0115453 A1 8/2002 Poulin et al.  
 2002/0119770 A1 8/2002 Twitchell, Jr.  
 2002/0119789 A1 8/2002 Friedman  
 2002/0120475 A1 8/2002 Morimoto  
 2002/0140081 A1 10/2002 Chou et al.  
 2002/0193121 A1 12/2002 Nowak et al.  
 2003/0003943 A1 1/2003 Bajikar  
 2003/0009410 A1 1/2003 Ramankutty et al.  
 2003/0013445 A1 1/2003 Fujiwara et al.  
 2003/0069759 A1 4/2003 Smith  
 2003/0151507 A1 8/2003 Andre et al.  
 2003/0163287 A1 8/2003 Vock  
 2003/0204132 A1 10/2003 Suzuki et al.  
 2004/0034470 A1 2/2004 Workman  
 2004/0046637 A1 3/2004 Wesby Van Swaay  
 2004/0114731 A1 6/2004 Gillett et al.

2004/0117108 A1 6/2004 Nemeth  
 2004/0233065 A1 11/2004 Freeman  
 2006/0173444 A1 8/2006 Choy et al.  
 2007/0156286 A1 7/2007 Yamauchi  
 2008/0021645 A1 1/2008 Lau et al.  
 2008/0261636 A1 10/2008 Lau et al.  
 2009/0042540 A1 2/2009 Bodnar et al.  
 2011/0022533 A1 1/2011 Lau et al.  
 2011/0223884 A1 9/2011 Lau et al.

FOREIGN PATENT DOCUMENTS

EP 1 037 447 A2 9/2000  
 EP 1 037 447 A3 10/2001  
 JP 11-64482 3/1999  
 JP 11-258325 9/1999  
 JP 11-289574 10/1999  
 JP 11-306491 11/1999  
 WO WO 97/14054 4/1997  
 WO WO 97/41654 11/1997  
 WO WO 98/01769 A1 1/1998  
 WO WO 98/16045 4/1998  
 WO WO 98/40837 9/1998  
 WO WO 00/51391 8/2000  
 WO WO 01/45343 A2 6/2001  
 WO WO 01/50151 A1 7/2001  
 WO WO 01/63318 A1 8/2001  
 WO WO 01/75700 A2 10/2001  
 WO WO 02/42979 A1 5/2002  
 WO WO 02/084618 A1 10/2002  
 WO WO 03/012720 A1 2/2003

OTHER PUBLICATIONS

"352C22 Miniature Low Profile ICP Accelerometer," Precision Accelerometers, PCB Piezoelectronics Products—SVS Division, webpages, pp. 1-2 (downloaded Apr. 11, 2002: [www.pcb.com/products/svs/svs352c22.html](http://www.pcb.com/products/svs/svs352c22.html)).  
 "3G Mobile Internet Revolution, . . . only with Location Based Services!" pp. 1, (downloaded Aug. 10, 2002: <http://webhome.idirect.com/~dental/3glocator/home.htm>).  
 "Airline Cargo Containers," Case Study, RJI Incorporated, webpages, pp. 1-2 (downloaded Mar. 16, 2002: [www.rji.cc/casestudies/airlinecargocounters.html](http://www.rji.cc/casestudies/airlinecargocounters.html)).  
 "Airline Food Carts," Case Study, RJI Incorporated, webpages, pp. 1-2 (downloaded Mar. 16, 2002: [www.rji.cc/casestudies/airlinefoodcarts.html](http://www.rji.cc/casestudies/airlinefoodcarts.html)).  
 "An Introduction to SnapTrack Server-Aided GPS Technology," SnapTrack Inc.  
 "Audiovox Intros GPS, Bluetooth Phone;" INT Media Group, Inc. (allNetDevices), Apr. 5, 2002. (downloaded: [www.allnetdevices.com/wireless/news/2001/1/15/audiovox\\_intros.html](http://www.allnetdevices.com/wireless/news/2001/1/15/audiovox_intros.html)).  
 "Carrier and end-user applications for wireless location systems," TruePosition, Inc., pp. 1-7.  
 "Danger -Products" and "Hiphop Communicator Brochure," Danger, Inc., downloaded Oct. 26, 2003: [www.danger.com/products.php](http://www.danger.com/products.php).  
 "Developing a GPSs for the Global Supply Chain," Aberdeen Group, Inc., Executive White Paper, Jun. 2002.  
 "Devices for Text Messages in Deutsche Telekom's fixed network have already found their way into many households," Deutsche Telekom AG, Press Release, Mar. 13, 2002, pp. 1-2.  
 "Digital/Analog Compass Sensors" and "1655 Digital Compass Sensor," webpages, The Robson Company, Inc., pp. 1-2 (downloaded Apr. 11, 2002: [www.dinmoresensors.com/index.html](http://www.dinmoresensors.com/index.html)).  
 "EarthTrack™ Vehicle Tracking Systems," Outfitter Satellite, Inc., 1998 (downloaded Jan. 22, 2000).  
 "Enhanced Tracking," United Parcel Service of America, Inc. (UPS), webpages, pp. 1-2 (downloaded Jun. 1, 2002: [www.ups.com/myupsinfo/info/etrack?pnav=stdservice](http://www.ups.com/myupsinfo/info/etrack?pnav=stdservice)).  
 "Fleet Management Systems-Asset Tracking Devices," Axiom Navigation Inc., 2000-2001 (downloaded Oct. 19, 2002: [www.axiomnav.com/Prod\\_Systems/prod\\_system.asp](http://www.axiomnav.com/Prod_Systems/prod_system.asp)).  
 "Frozen Food Warehouse," Case Study, RJI Incorporated, webpages, pp. 1-3 (downloaded Mar. 16, 2002: [www.rji.cc/casestudies/frozenfoodwarehouse.html](http://www.rji.cc/casestudies/frozenfoodwarehouse.html)).

- "FunMail Launches on the NTT DoCoMo i-mode network," FunMail, Press Release, May 1, 2001, pp. 1-2.
- "Global Cell Phone Location," Axiom Navigation Inc., 2000-2001 (downloaded Oct. 19, 2002: [www.axiomnav.com/Prod\\_Global/prod\\_global.asp](http://www.axiomnav.com/Prod_Global/prod_global.asp)).
- "Global Locating Services," SkyBitz, webpage, p. 1, (downloaded Nov. 15, 2002: [www.skybitz.com/services/gls.html](http://www.skybitz.com/services/gls.html)).
- "GLS Communicator," SkyBitz, webpages, pp. 1-2, (downloaded Nov. 15, 2002: [www.skybitz.com/gls/communicator.html](http://www.skybitz.com/gls/communicator.html)).
- "Guide to Tracking Info.," Nippon Express, website page, p. 1 (downloaded Jun. 9, 2002: [www.niftsu.co.jp/edoc/howtoe.htm](http://www.niftsu.co.jp/edoc/howtoe.htm)).
- "Introduction to SMS," by C. Tull of AnywhereYouGo.com, pp. 1-4 (downloaded: [www.devx.com/wireless/articles/SMS/SMSintro.asp](http://www.devx.com/wireless/articles/SMS/SMSintro.asp)).
- "IO Data Develops GPS Adapter for I-Mode Mobile," AsiaBizTech, Sep. 17, 2002, pp. 1-2.
- "Locate Networks: Our Service," Locate Networks, webpages, pp. 1-7 (downloaded Sep. 26, 2002: [www.locatenetworks.com/](http://www.locatenetworks.com/)).
- "MMS phones: Don't believe the hype," CNN.com/SCI-TECH, Aug. 8, 2002, pp. 1-3.
- "Mobile Location Based Services: Cell Tracking Devices of People & Things . . ." pp. 1-2, (downloaded Aug. 10, 2002: <http://3glocate.com/>).
- "MoniTrack," Case Study, RJI Incorporated, webpages, pp. 1-2 (downloaded Mar. 16, 2002: [www.rji.cc/technology/telematic.html](http://www.rji.cc/technology/telematic.html)).
- "MY UPS.COM Benefits," United Parcel Service of America, Inc. (UPS), webpage, p. 1 (downloaded Apr. 13, 2002: [www.ups.com/myupsinfo/info/benefits?pnav=stdsservice](http://www.ups.com/myupsinfo/info/benefits?pnav=stdsservice)).
- "NavMate® Navigation System," Visteon Corporation, webpage, pp. 1-2 (downloaded Jun. 21, 2002: [www.visteon.com/technology/automotive/navmate.html](http://www.visteon.com/technology/automotive/navmate.html)).
- "News," SkyBitz, webpages, pp. 1-8, (downloaded Nov. 15, 2002: [www.skybitz.com/about/news.html](http://www.skybitz.com/about/news.html)).
- "Pakhound: Your Watchdog In The Shipping Industry," website pages, pp. 1-3 (downloaded Jun. 9, 2002: [www.pakhound.com/fact.asp](http://www.pakhound.com/fact.asp)).
- "Parkwatch and Wherenet Unveil the First Amusement Visitor Locating system," ParkWatch, Press Release, Jun. 27, 2000.
- "pulver.com's Location Based Services Report," pulver.com, Inc., Oct. 2001, pp. 1-17 (downloaded Jun. 4, 2002: [www.pulver.com/lbsreport/lastbsreport.02/oct01.txt](http://www.pulver.com/lbsreport/lastbsreport.02/oct01.txt)).
- "Radio Frequency Identification (RFID)," Case Study, RJI Incorporated, webpage, p. 1 (downloaded Mar. 16, 2002: [www.rji.cc/technology/rfid.html](http://www.rji.cc/technology/rfid.html)).
- "Real Time Location System (RTLS)," Case Study, RJI Incorporated, webpage, p. 1 (downloaded Mar. 16, 2002: [www.rji.cc/technology/rtls.html](http://www.rji.cc/technology/rtls.html)).
- "Real-Time Warehouse Tracking," Case Study, RJI Incorporated, webpages, pp. 1-2 (downloaded Mar. 16, 2002: [www.rji.cc/casestudies/rtwarehousetracking.html](http://www.rji.cc/casestudies/rtwarehousetracking.html)).
- "Savi Reusable Transport Container," Savi Technology, Inc., Apr. 30, 2002, pp. 1-2.
- "Send images to i-mode phones," Mobile Media Japan, 2001, pp. 1-3.
- "Ski Rental with Auto ID and Tracking," Case Study, RJI Incorporated, webpages, pp. 1-2 (downloaded Mar. 16, 2002: [www.rji.cc/casestudies/skirentalcompany.html](http://www.rji.cc/casestudies/skirentalcompany.html)).
- "SnapTrack and SignalSoft Corp. Team Up to Trial Location-based Information Service for GSM Test Group," Press Release, SnapTrack Inc., Dec. 6, 1999.
- "SnapTrack Awarded Additional Key Patents for Enhanced GPS System," Press Release, SnapTrack Inc., Jan. 4, 2000.
- "Start-up crams single chip with phone, GPS and Bluetooth," CNET Network, Inc. (ZDNET), Mar. 22, 2002 (downloaded: <http://news.zdnet.co.uk/story/0,1284-x2107163,00.html>).
- "Status Icons/Messages," Yahoo! Messenger Help, Yahoo! Inc., 2002, pp. 1-2.
- "Technical Applications of Our Current Technology," Aetherwire, webpages, pp. 1-4 (downloaded Mar. 16, 2002: [www.aetherwire.com/CDROM/General/appl1.html](http://www.aetherwire.com/CDROM/General/appl1.html)).
- "The Always on Network," Position Paper, Nortel Networks, 2002.
- "Theme Park Visitors & Cashless Purchasing," Case Study, RJI Incorporated, webpages, pp. 1-2 (downloaded Mar. 16, 2002: [www.rji.cc/casestudies/themepark.html](http://www.rji.cc/casestudies/themepark.html)).
- "Track Shipments—Detailed Results," FedEx, webpages, pp. 1-2 (downloaded Oct. 29, 2002: [www.fedex.com](http://www.fedex.com)).
- "Track Your FedEx Shipments via Email," FedEx, webpages, pp. 1-2 (downloaded Oct. 29, 2002: [www.fedex.com](http://www.fedex.com)).
- "Tracking Helpful Tips," United Parcel Service of America, Inc. (UPS), webpages, pp. 1-2 (downloaded Jun. 1, 2002: [www.ups.com/tracking/nm\\_help.html](http://www.ups.com/tracking/nm_help.html)).
- "Trimble and Rosum Team to Develop Universal Positioning Technology," Trimble Navigation, Inc., News Release, Feb. 27, 2003.
- "Turning Position Into Knowledge," SkyBitz, webpage, p. 1, (downloaded Nov. 15, 2002: [www.skybitz.com](http://www.skybitz.com)).
- "UPS Package Tracking," United Parcel Service of America, Inc. (UPS), webpages, pp. 1-2 (downloaded Apr. 13, 2002: [www.ups.com/tracking/tracking.html](http://www.ups.com/tracking/tracking.html)).
- "UPS Wireless Solutions," United Parcel Service of America, Inc. (UPS), webpage, p. 1 (downloaded Apr. 13, 2002: [www.ups.com/myupsinfo/info/wireless?pnav=stdsservice](http://www.ups.com/myupsinfo/info/wireless?pnav=stdsservice)).
- "Welcome to Iship, Inc.," iShip, Inc., webpages, pp. 1-2, (downloaded Jun. 9, 2002: [www.iship.com/](http://www.iship.com/)).
- "Welcome to Traker Systems," Tracker Systems, webpages, pp. 1-2 (downloaded Jun. 9, 2002: [www.trakersystems.com](http://www.trakersystems.com)).
- "What are Instant Messages?" Yahoo! Messenger Help, Yahoo! Inc., 2002, pp. 1.
- "What is '3G' technology?," CNN.com/SCI-TECH, Oct. 22, 2001, pp. 1-3.
- "What is a Friend List?" Yahoo! Messenger Help, Yahoo! Inc., 2002, pp. 1.
- "Wherify Wireless and SiRF Team to Deliver Child Locator System," Wherify Wireless, Inc., Press Release, Mar. 19, 2001, pp. 1-2.
- "Wherify Wireless Breakthrough in Location-Based Services," Mobilemag.com, Feb. 28, 2001, p. 1.
- "Wherify Wireless GPS Locator for Kids User Guide," Wherify Wireless, Inc., 2003, pp. 1-106.
- "Wherify Wireless Location Services," Wherify Wireless, Inc., webpages, pp. 1-5 (downloaded: Mar. 25, 2003: [www.wherifywireless.com/prod\\_watches.htm](http://www.wherifywireless.com/prod_watches.htm)).
- "X-GPSTM—Hybrid GPS Location Server Solution," Axiom Navigation Inc., 2000-2001 (downloaded Oct. 19, 2002: [www.axiomnav.com/Prod\\_Global/x-gps.asp](http://www.axiomnav.com/Prod_Global/x-gps.asp)).
- "Yahoo! Messenger—Sending Messages to a Mobile Phone," Yahoo! Messenger, Yahoo! Inc., 2002, pp. 1-7 (downloaded Oct. 27, 2002: [http://messenger.yahoo.com/messenger/wireless/pc2sms/tour1.html\(through\\_tour7.html\)](http://messenger.yahoo.com/messenger/wireless/pc2sms/tour1.html(through_tour7.html))).
- "Yahoo! Messenger for Text Messaging," Yahoo! Messenger, Yahoo! Inc., 2002, pp. 1-10 (downloaded Oct. 27, 2002: [http://messenger.yahoo.com/messenger/wireless/smsmsg/tour1.html\(through\\_tour7.html\)](http://messenger.yahoo.com/messenger/wireless/smsmsg/tour1.html(through_tour7.html))).
- "Yahoo! Messenger for WAP," Yahoo Messenger, Yahoo! Inc., 2002 (tours 1-9), pp. 1-17 (downloaded Oct. 27, 2002: [www.messenger.yahoo.com/messenger/wireless/wap/tour1.html\(through\\_tour9.html\)](http://www.messenger.yahoo.com/messenger/wireless/wap/tour1.html(through_tour9.html))).
- Accelerometers—General Purpose, LP Series, Crossbow Technology, Inc., data sheet, pp. 1-3 (downloaded Apr. 11, 2002: [www.xbow.com/Products/Accelerometers.htm](http://www.xbow.com/Products/Accelerometers.htm)).
- Bickers, "Eyes in the sky," SafeTzone Technology Corporation, webpages, 2001, pp. 1-3 (downloaded: [www.safetzone.com/newsKiosk.asp](http://www.safetzone.com/newsKiosk.asp)).
- Chertkoff, Rachel, "Vehicle Locator Systems," Pager Technology, pp. 1-2, 1998.
- Commercial Uses for LoJack (webpage), LoJack Corporation, downloaded Jan. 22, 2000.
- Crossbow Product Guide—Accelerometers, Crossbow Technology, Inc., webpages, pp. 1-3 (downloaded Apr. 11, 2002: [www.xbow.com/Products/Accelerometers.htm](http://www.xbow.com/Products/Accelerometers.htm)).
- Delphi and MobileAria Demonstrate True Hands Free In-Vehicle Mobile Productivity Services At CES, Press Release, Delphi Automotive Systems, Jan. 8, 2002 (downloaded Apr. 5, 2002: [www.delphiauto.com/news/pressRelease/pr6828-01082002](http://www.delphiauto.com/news/pressRelease/pr6828-01082002)).
- F. Rivera, "Special Report: Keeping Tabs on Your Teen," 7 News, Boston, Apr. 30, 2002, pp. 1-3.
- FedEx Insight, FedEx, webpages, pp. 1-11 (downloaded Oct. 29, 2002: [www.fedex.com](http://www.fedex.com)).

- GPS2000, Omega Research and Development, Inc., webpages, pp. 1-9 (pp. 7-9 pertain to an online tour) (downloaded Jul. 14, 2003: [www.gps2000online.com/](http://www.gps2000online.com/)).
- IMVironment, Yahoo! Messenger Yahoo! Inc., 2002, pp. 1-12 (downloaded (including) Oct. 27, 2002: [http://help.yahoo.com/help/us/mesg/imv/imv-01.html\(through/index5.html\)](http://help.yahoo.com/help/us/mesg/imv/imv-01.html(through/index5.html))).
- J.Wrolstad, "Chrysler Claims First With Bluetooth Mobile Phone System," Wireless Newsfactor, Oct. 26, 2001.
- K. Hill, "Prada Uses Smart Tags to Personalize Shopping," CRMDaily.com, Apr. 24, 2002., pp. 1-4.
- K. Miyake, "Sharp to unveil 3G PDA-type cell phone," ITworld.com, Inc., Jan. 11, 2002.
- Kleinknecht, William, "Juvenile authorities want satellite tracking for felons," The Star-Ledger of New Jersey, Nov. 18, 1997.
- LoadTrak, pp. 1-2 (downloaded Jun. 4, 2002: [www.load-trak.com](http://www.load-trak.com)).
- Marek, "The Unstoppable SnapTrack," Wireless Week, Dec. 18, 2000.
- Motorola Consumer Catalog: Pagers (webpage), Motorola, Inc., downloaded Jan. 19, 2000.
- My.Roadway!, Roadway Express, Inc., webpages, pp. 1-2, (downloaded Jun. 9, 2002: [www.quicktrak.roadway.com/cgi-bin/quicktrak](http://www.quicktrak.roadway.com/cgi-bin/quicktrak)).
- Packtrack™, PackTrack.com, webpages, pp. 1-2 (downloaded Jun. 9, 2002: [www.packtrack.com](http://www.packtrack.com)).
- Precision Accelerometers, PCB Piezoelectronics Products—SVS Division, webpages, pp. 1-2 (downloaded Apr. 11, 2002: [www.pcb.com/products/svs/index.html](http://www.pcb.com/products/svs/index.html)).
- Rabinowitz and Spilker, Jr., "A New Positioning System Using Television Synchronization Signals," Rosum Corporation, pp. 1-11 (downloaded May 21, 2003).
- Rabinowitz and Spilker, Jr., "Positioning Using the ATSC Digital Television Signal," Rosum Corporation Whitepaper, Rosum Corporation (downloaded May 21, 2003).
- Real Time Locating System, Executive Summary, Technology Systems International, Inc.
- Ryan, "Catching up with Dick Tracy," San Francisco Chronicle, news article, Mar. 18, 2002.
- SandPiper GPS Receiver, Specification sheet by Axiom Navigation Inc. ([www.axiomnav.com](http://www.axiomnav.com)).
- Smart Antenna, Specification sheet by Axiom Navigation Inc. ([www.axiomnav.com](http://www.axiomnav.com)).
- SnapTrack—Privacy Protection (webpage), SnapTrack Inc., downloaded Jan. 19, 2000.
- SnapTrack—Technology At Work (webpage), SnapTrack Inc., downloaded Jan. 19, 2000.
- SnapTrack in Action (webpage), SnapTrack Inc., downloaded Jan. 19, 2000.
- Stulp, Louis A., "Examining the Coming Revolution in Location Services," pp. 1-11.
- Swift A2 GPS Receiver, Specification sheet by Axiom Navigation Inc. ([www.axiomnav.com](http://www.axiomnav.com)).
- Swift B2 GPS Receiver, Specification sheet by Axiom Navigation Inc. ([www.axiomnav.com](http://www.axiomnav.com)).
- TruePosition Virtual Brochure (webpage), TruePosition, Inc.
- Wong, "Fishers, golfers join the rush to GPS," San Jose Mercury News, news article, Mar. 25, 2002.
- Appenzeller, et al., "The Mobile People Architecture", Technical Report: CSL-TR-00000, Computer Systems Laboratory, Departments of Electrical Engineering and Computer Science, Stanford University, Jan. 1999, pp. 1-13.
- Calsyn, Martin and Desseault, Lisa, "Presence Information Protocol Requirements," Internet Draft, Feb. 9, 1998, pp. 1-27.
- J. Rosenberg, H. Schulzrinne, Internet Draft, "SIP for Presence," <http://www.alternic.org/drafts/drafts-r-s/draft-rosenberg=sip-pip-00.txt>, Nov. 13, 1998, Bell Laboratories, Columbia, pp. 1-31.
- Office Action for U.S. Appl. No. 09/797,517, dated Jul. 31, 2003.
- Office Action for U.S. Appl. No. 09/797,517, dated Jan. 28, 2004.
- Office Action for U.S. Appl. No. 09/797,517, dated Jun. 4, 2004.
- Office Action for U.S. Appl. No. 09/797,517, dated Feb. 18, 2005.
- Office Action for U.S. Appl. No. 09/797,517, dated Sep. 12, 2005.
- Advisory Action for U.S. Appl. No. 09/797,517, dated Dec. 16, 2005.
- Advisory Action for U.S. Appl. No. 09/797,517, dated Mar. 20, 2006.
- Office Action for U.S. Appl. No. 09/797,517, dated Jun. 5, 2006.
- Office Action for U.S. Appl. No. 09/797,517, dated Dec. 20, 2006.
- Office Action for U.S. Appl. No. 09/797,517, dated Jul. 17, 2007.
- Office Action for U.S. Appl. No. 09/797,517, dated Oct. 11, 2007.
- U.S. Appl. No. 12/150,203 filed Apr. 28, 2008.
- Office Action for U.S. Appl. No. 12/150,203 dated May 6, 2010.
- Office Action for U.S. Appl. No. 12/150,203, dated Nov. 12, 2010.
- First Amended Complaint for Patent Infringement, EDTX, Case 1:10-cv-00547-RC, filed Sep. 24, 2010, pp. 1-29.
- Complaint for Patent Infringement, NDCA, Case cv10-04755V HRL, filed Oct. 20, 2010, pp. 1-22, including Exhibit 17 (60 pgs.), Exhibit 27 (57 pgs.), and Exhibit 38 (54 pgs.) [total 193 pgs.].
- Amended Complaint for Patent Infringement, NDCA, Case No. cv10-4755 JSW, filed Feb. 4, 2011, pp. 1-23.
- Answer to Amended Complaint (AT&T), NDCA, Case No. cv10-4755 JSW, filed Feb. 18, 2011, pp. 1-15.
- Answer to Amended Complaint (Sprint), NDCA, Case No. cv10-4755 JSW, filed Feb. 18, 2011, pp. 1-15.
- Answer to Amended Complaint (Verizon), NDCA, Case No. cv10-4755 JSW, filed Feb. 18, 2011, pp. 1-22.
- Danger Product Overview, 5 pgs., Danger, Inc., est. 2001.
- PCVtrak™ Installation and Operator's Manual, Trimble Navigation, 24623-00 Rev. A, May 1994, pp. 1-259.
- "Advanced Traveler Aid Systems for Public Transportation," Final Report, Federal Transit Administration, Sep. 1994, pp. 1-131.
- Campbell, Laurel, "SECURITY—Military satellite enlisted to thwart car crime," The Commercial Appeal, Sep. 26, 1996, pp. 5B.
- Law, Alex, "Week in Wheels/ . . . From a Driver's Notebook," Newsday, Inc., Sep. 20, 1996, pp. C03.
- Cortez, Angela, "Springs police can track thief, vehicles," The Denver Post, Sep. 10, 1996, pp. B-01.
- "OnGuard Tracker Nabs Auto Burglar," Global Positioning & Navigation News, vol. 6, No. 16, Aug. 8, 1996.
- "OnGuard Tracker Nabs Auto Burglar," Section: Financial News, PR Newswire, Jul. 29, 1996.
- Nauman, Matt, "Pressing the Panic Button: Car Security Enters a New Age with Cellular Phones and Satellites that Watch Over You," San Jose Mercury News, Jun. 21, 1996, pp. 1G.
- "Monday Briefing" San Antonio Express-News, p. 1, Part B, Jun. 10, 1996.
- "OnGuard Tracker Makes Debut on 'One Lap of America,'" PR Newswire, Jun. 7, 1996.
- "OnGuard Tracker Makes Debut on 'One Lap of America,'" Southwest Newswire, Jun. 7, 1996.
- Dominguez, Raul, "Women get their day in sun—American Golf planning events nationwide May 18," San Antonio Express-News, Apr. 18, 1996, pp. 2, part B.
- "Vehicle Navigation Units Being Measured in Luxury Autos," Global Positioning & Navigation News, vol. 6, No. 7, Apr. 4, 1996.
- "Advanced Business Sciences, Inc. Announces Completion of Acquisition of Comguard of Illinois," Business Wire, Aug. 26, 1998.
- "Advanced Business Sciences, Inc. Announces Filing With Securities and Exchange Commission," Business Wire, Jun. 25, 1999.
- "Advanced Business Sciences, Inc. Announces Preliminary Fourth Quarter 1998 Revenue Results," Business Wire, Feb. 4, 1999.
- "Business People Burnsy's Grill Names Two," Omaha World-Herald, Section Business, p. 4M, Oct. 20, 1996.
- "Company Sees Prisoner Tracking and Monitoring Market Niche," Global Positioning & Navigation News, vol. 6, No. 10, May 16, 1996.
- GPS-Based Personal Monitoring Systems Offered to Corrections, Private Market, Global Positioning & Navigation News, vol. 8, No. 11, Jun. 3, 1998.
- GPS tracks parolees, probationers, Corrections Professional, vol. 5, No. 6, Nov. 19, 1999.
- High-Tech System Tracks Offenders—Satellites Watching Criminals, Business Wire, Nov. 14, 1997.
- Briefs, Global Positioning & Navigation News, vol. 9, No. 4, Feb. 24, 1999.
- Dunkelberger, Lloyd, "Lawmakers question criminal-tracking system," Sarasota Herald-Tribune (Florida), pp. 16A, Nov. 28, 1999.
- Powell, Barbara, "New gadgets help drivers find their way," Fort Worth Star-Telegram (Texas), p. 1, Jan. 20, 1997.
- "New Service Lets Corrections Agencies Track Offenders by Satellite," PR Newswire, Jan. 11, 1999.



- "New Service Lets Corrections Agencies Track Offenders by Satellite; SecurityLink Offers "GPS" Tracking for Offenders on Electronic Monitoring—Sandusky Municipal Court Adopts Technology for Local Offenders," PR Newswire, Jan. 12, 1999.
- "New Service Lets Corrections Agencies Track Offenders by Satellite; SecurityLink Offers "GPS" Tracking for Offenders on Electronic Monitoring," PR Newswire, Section: Financial News, Jan. 11, 1999.
- "New Service Lets Corrections Agencies Track Offenders by Satellite," Satellite Today, vol. 2, No. 8, Jan. 13, 1999.
- "Prisoner Security Monitoring Company Grabs Contracts for GPS-Based System," Global Positioning & Navigation News, vol. 7, No. 1, Jan. 15, 1997.
- Atwater, Andi, "Proposal seeking 24-hour tracking of all sex offenders," The News-Press (Fort Meyers, FL), pp. 1A, Feb. 20, 2000.
- Briefs, Global Positioning & Navigation News, vol. 9, No. 3, Feb. 10, 1999.
- Brauer, David, "Satellite 'Big Brother' Tracks Ex-Inmates; Agencies Experiment with GPS to Monitor Parolee Whereabouts," Chicago Tribune, Section: News, p. 31, Dec. 18, 1998.
- "Satellite Spotlight; Eye in the Sky to Monitor Parolees," Satellite News, vol. 21, No. 15, Apr. 13, 1998.
- "Satellite Spotlight: Fighting Crime From Space," Satellite News, vol. 19, No. 20, May 13, 1996.
- Prohaska, Thomas J. "Satellite Will Keep Tabs on Convicts," Buffalo News (New York), Section: Local, p. 5B, Sep. 20, 1999.
- "Sierra Wireless and Pro Tech Team Up on Monitoring Product," Global Positioning & Navigation News, vol. 8, No. 8, Apr. 22, 1998.
- Anderson, Larry, "Technology rules at Securing New Ground," Access Control & Security Systems Integration, Section: Industry Outlook; ISSN 1084-6425, Dec. 1999.
- Trimble Navigation Warns 2nd-Quarter Earnings to Miss Target, Dow Jones Business News, Jul. 10, 1998.
- "Trimble Navigation's Net Income Skidded 93% Amid Order Delays," Dow Jones Business News, Jul. 23, 1998.
- Briefs, Global Positioning & Navigation News, vol. 9, No. 2, Jan. 27, 1999.
- Briefs, Global Positioning & Navigation News, vol. 9, No. 14, Jul. 14, 1999.
- Dailey et al. "Automatic Transit Location System," Final Research Report, 55 pgs., Feb. 1996.
- Maguire, Jr. et al. "SmartBadges: a wearable computer and communication system," codes/CASHE '98, 47 pgs., 1998.
- Koshima et al. "Personal locator services emerge," IEEE Spectrum, Feb. 2000, pp. 41-48.
- Zygowicz et al. "State of the Art in Automatic Vehicle Location Systems," Center for Urban Transportation Studies, University of Wisconsin, Milwaukee, Feb. 1998.
- Ashworth, Jon. "Big brother is watching you," The Times (London), Section: Features, May 7, 1999.
- "Car Thieves Take the 'Bait' in Michigan; Two Suspects Reeled in With OnGuard," Business Wire, Sep. 11, 1997.
- Sauer, Matthew, "Company Finds Niche by Giving Directions . . ." Sarasota Herald-Tribune (Florida), Section: Business Weekly, p. 1, Jul. 7, 1997.
- "ATX Technologies Signs Nationwide Service Deal with AT&T," Global Positioning & Navigation News, vol. 7, No. 9, May 7, 1997.
- "Car Thieves Take the 'Bait' in Tulsa; Two Suspects Caught Off Guard with OnGuard Once Again," PR Newswire, Section: Financial News, Jan. 8, 1997.
- "Car Thieves Take the 'Bait' in Tulsa; Two Suspects Caught Off Guard with on Guard," PR Newswire, Section: Financial News, Dec. 9, 1996.
- Jackson, Terry, "Smart Cars Whether by Satellite or the Internet, High-Tech Devices and Services May Make Crumpled Road Maps a Thing of the Past," The Miami Herald, Section: Travel, p. 1J, Oct. 6, 1996.
- "San Antonio Personal Security Company Links Up with Senior PGA Golfer," PR Newswire, Section: Financial News, Apr. 1, 1996.
- "San Antonio Personal Security Company Links Up with Senior PGA Golfer," Southwest Newswire, Apr. 1, 1996.
- Business Briefs, San Antonio Express-News, Mar. 25, 1996.
- "ATX Research Signs Exclusive Sales Agreement with Arizona Company," PR Newswire, Mar. 21, 1996.
- "ATX Research Signs Exclusive Sales Agreement with Arizona Company," Southwest Newswire, Mar. 21, 1996.
- "Automotive GPS Satellite/Safety System Race is on," Southwest Newswire, Feb. 20, 1996.
- "Dealerships Can Track Down New Aftermarket Revenues," PR Newswire, Feb. 9, 1996.
- "ATX Research Unveils New Stealthrac Capability," PR Newswire, Feb. 9, 1996.
- "Dealerships Can Track Down New Aftermarket Revenues," Southwest Newswire, Feb. 9, 1996.
- Briefs, Global Positioning & Navigation News Wire, vol. 6, No. 2, Jan. 24, 1996.
- "ATX Research Provides Police Departments With OnGuard Personal Security and Vehicle Tracking System," PR Newswire, Jan. 15, 1996.
- "ATX Research Provides Police Departments With OnGuard Personal Security and Vehicle Tracking System," Southwest Newswire, Jan. 15, 1996.
- "ATX Research Relocates to New Corporate Headquarters," PR Newswire, Dec. 12, 1995.
- "ATX Research Relocates to New Corporate Headquarters," Southwest Newswire, Dec. 12, 1995.
- "Texas invention tracks stolen cars, lets driver call for help," The Vancouver Sun, Oct. 20, 1995.
- "San Antonio Company Unveils Satellite/Cellular Personal Security System," PR Newswire, Oct. 3, 1995.
- "San Antonio Company Unveils Satellite/Cellular Personal Security System," Southwest Newswire, Oct. 3, 1995.
- Preliminary Claim Constructions and Supporting Evidence for U.S. Patent No. 7,366,522 Pursuant to Patent L.R. 4-2, NDCA, Case CV 10-04755 JSW, filed Jun. 3, 2011, pp. 1-29, including Exhibit A.
- Defendants Invalidation Contentions, NDCA, Case 3:10-cv-04755-JSW, filed May 3, 2011, pp. 1-1249, including Exhibit A (60 pgs.), Exhibit B (59 pgs.), Exhibit C (27 pgs.), Exhibit D (26 pgs.), Exhibit E (35 pgs.), Exhibit F (40 pgs.), Exhibit G (31 pgs.), Exhibit H (34 pgs.), Exhibit I (43 pgs.), Exhibit J (44 pgs.), Exhibit K-1 (49 pgs.), Exhibit K-2 (54 pgs.), Exhibit L-1 (50 pgs.), Exhibit L-2 (57 pgs.), Exhibit M1 (45 pgs.), Exhibit M-2 (54 pgs.), Exhibit N-1 (35 pgs.), Exhibit N-2 (51 pgs.), Exhibit O-1 (51 pgs.), Exhibit O-2 (36 pgs.), Exhibit P-1 (40 pgs.), Exhibit P-2 (39 pgs.), Exhibit Q-1 (36 pgs.), Exhibit Q-2 (42 pgs.), Exhibit R-1 (40 pgs.), Exhibit R-2 (43 pgs.), Exhibit S-1 (44 pgs.), Exhibit S-2 (41 pgs.).
- Cellco Partnership's Proposed Terms for Construction, NDCA, Case 3:10-cv-04755-JSW, filed May 13, 2011, pp. 1-4.
- Cellco Partnership's Preliminary Claim Constructions, NDCA, Case 3:10-cv-04755-JSW, filed Jun. 3, 2011, pp. 1-9.
- Amended Final Joint Claim Construction Statement, NDCA, Case 3:10-cv-04755-JSW, filed Sep. 13, 2011, pp. 1-34.
- Defendant AT&T Mobility, LLC's and Spring Spectrum and Nextel Operations' Proposed Terms and Claim Elements for Construction, NDCA, Case 3:10-cv-04755-JSW, filed May 13, 2011, pp. 1-4.
- Defendant AT&T Mobility, LLC's and Sprint Spectrum and Nextel Operations' Exchange of Preliminary Claim Constructions and Extrinsic Evidence, NDCA, Case 3:10-cv-04755, filed Jun. 3, 2011, pp. 1-15.
- Defendant AT&T Mobility LLC's, Sprint Spectrum LP's and Nextel Operations' Responsive Claim Construction Brief, NDCA, Case 3:10-cv-04755-JSW, filed Sep. 2, 2011, pp. 1-210, including Exhibit 1 (13 pgs.), Exhibit 2 (15 pgs.), Exhibit 3 (16 pgs.), Exhibit 4 (14 pgs.), Exhibit 5 (13 pgs.), Exhibit 6 (15 pgs.), Exhibit 7 (12 pgs.), Exhibit 8 (5 pgs.), Exhibit 9 (9 pgs.), Exhibit 10 (2 pgs.), Exhibit 11 (12 pgs.), Exhibit 12 (13 pgs.), Exhibit 13 (12 pgs.), Exhibit 14 (3 pgs.), Exhibit 15 (3 pgs.), Exhibit 16 (4 pgs.).
- Defendants' Objections to IpVenture's Claim Construction Reply Brief Evidence, NDCA, Case 3:10-cv-04755-JSW, filed Sep. 20, 2011, pp. 1-22.
- Plaintiff IpVenture, Inc.'s Reply Claim Construction Brief, NDCA, Case 3:10-cv-04755-JSW, filed Sep. 13, 2011, pp. 1-36.
- Plaintiff IpVenture, Inc.'s First Amended Responses to Defendant AT&T Mobility LLC's Second Set of Interrogatories to Plaintiff (No. 7), NDCA, Case 3:10-cv-04755 JSW, filed Aug. 29, 2011, pp. 1-8.
- Plaintiff IpVenture, Inc.'s Answers to Defendant AT&T Mobility LLC's Third Set of Interrogatories to Plaintiff (No. 10), NDCA, Case 3:10-cv-04755 JSW, filed Aug. 12, 2011, pp. 1-15.

- Plaintiff IpVenture, Inc.'s Answers to Defendant AT&T Mobility, LLC's Second Set of Interrogatories (Nos. 7-9), NDCA, Case 3:10-cv-04755 JSW, filed Jun. 7, 2011, pp. 1-10.
- Plaintiff IpVenture, Inc.'s Responses to Defendant Cellco Partnership's First Set of Interrogatories (Nos. 1-14), NDCA, Case 3:10-cv-04755 JSW, filed Apr. 18, 2011, pp. 149.
- Plaintiff IpVenture, Inc.'s Opening Claim Construction Brief, NDCA, Case No. C 10-04755 JSW, filed Aug. 12, 2011, pp. 1-24.
- Docket Listing, NDCA, Case 3:10-cv-04755-JSW, printed Jan. 6, 2012, pp. 1-12.
- Notice of Allowance for U.S. Appl. No. 09/797,517, dated Jan. 14, 2008.
- Final Office Action for U.S. Appl. No. 12/150,203, dated Apr. 25, 2011.
- Archived copy of a page entitled "Money-Back Guarantee Policy" from fedex.com, archived by the Internet Archive on Aug. 17, 2000.
- Strom, Stephanie. "A Wild Sleigh Ride at Federal Express," *The New York Times*, Dec. 20, 1994.
- Culler et al., MICA: The Commercialization of Microsensor Motes, *Sensors*, vol. 19, No. 4 (Apr. 1, 2002).
- Darabi et al., A 2.4-GHz CMOS Transceiver for Bluetooth, *IEEE Journal of Solid-State Circuits*, vol. 36, No. 12 (Dec. 2001).
- J. Fraden, *Handbook of Modern Sensors*, Springer-Verlag (1996).
- Grimes, Craig A., et al., *Wireless Magnetoelastic Resonance Sensors: A Critical Review*, *Sensors* (Jul. 23, 2002).
- Helfenstein et al. *Circuits and Systems for Wireless Communications*, Kluwer Academic Publishers (2000).
- Hill et al., *System Architecture Directions for Networked Sensors*, *ACM/ASPLOS-IX* (Nov. 2000).
- Madou, Marc J., *Fundamentals of Microfabrication*, CRC Press (2002).
- Mainwaring et al., *Wireless Sensor Networks for Habitat Monitoring*, *ACM* (Sep. 28, 2002).
- Razavi, Behzad, *RF Microelectronics*, Prentice Hall (1998).
- Rofougaran et al., A Single-Chip 900-MHz Spread-Spectrum Wireless Transceiver in 1- $\mu\text{m}$  CMOS-Part II: Receiver Design, *IEEE Journal of Solid-State Circuits*, vol. 33, No. 4 (Apr. 1998).
- Senturia, Stephen D., *Microsystem Design*, Kluwer Academic Publishers (2001).

\* cited by examiner

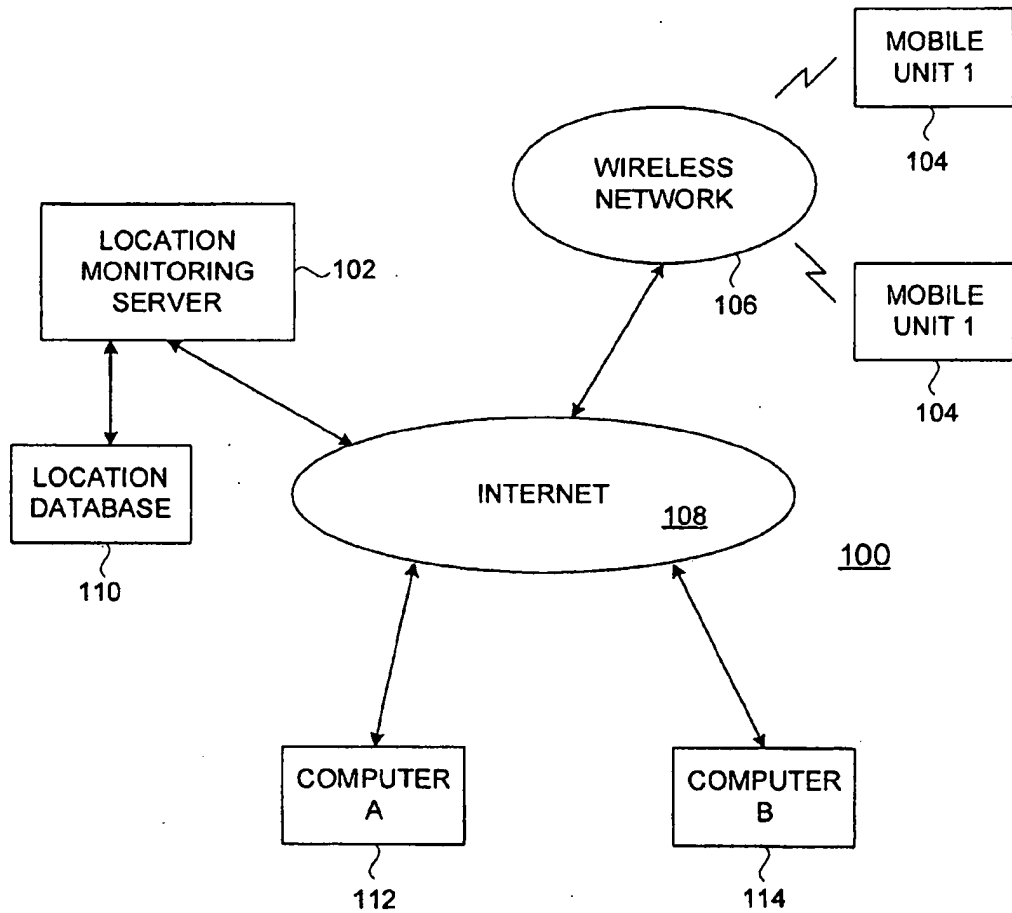

FIG. 1

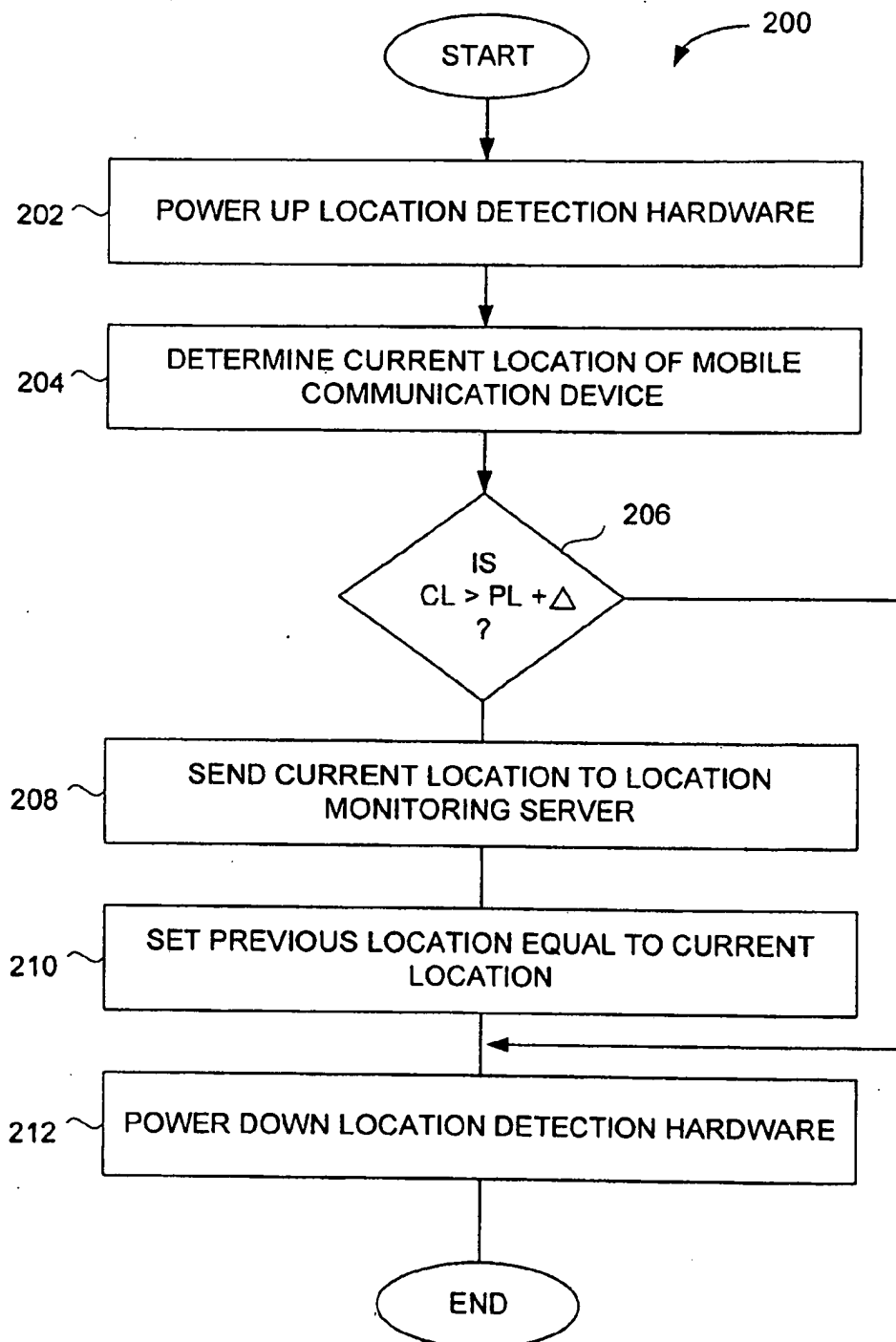

FIG. 2

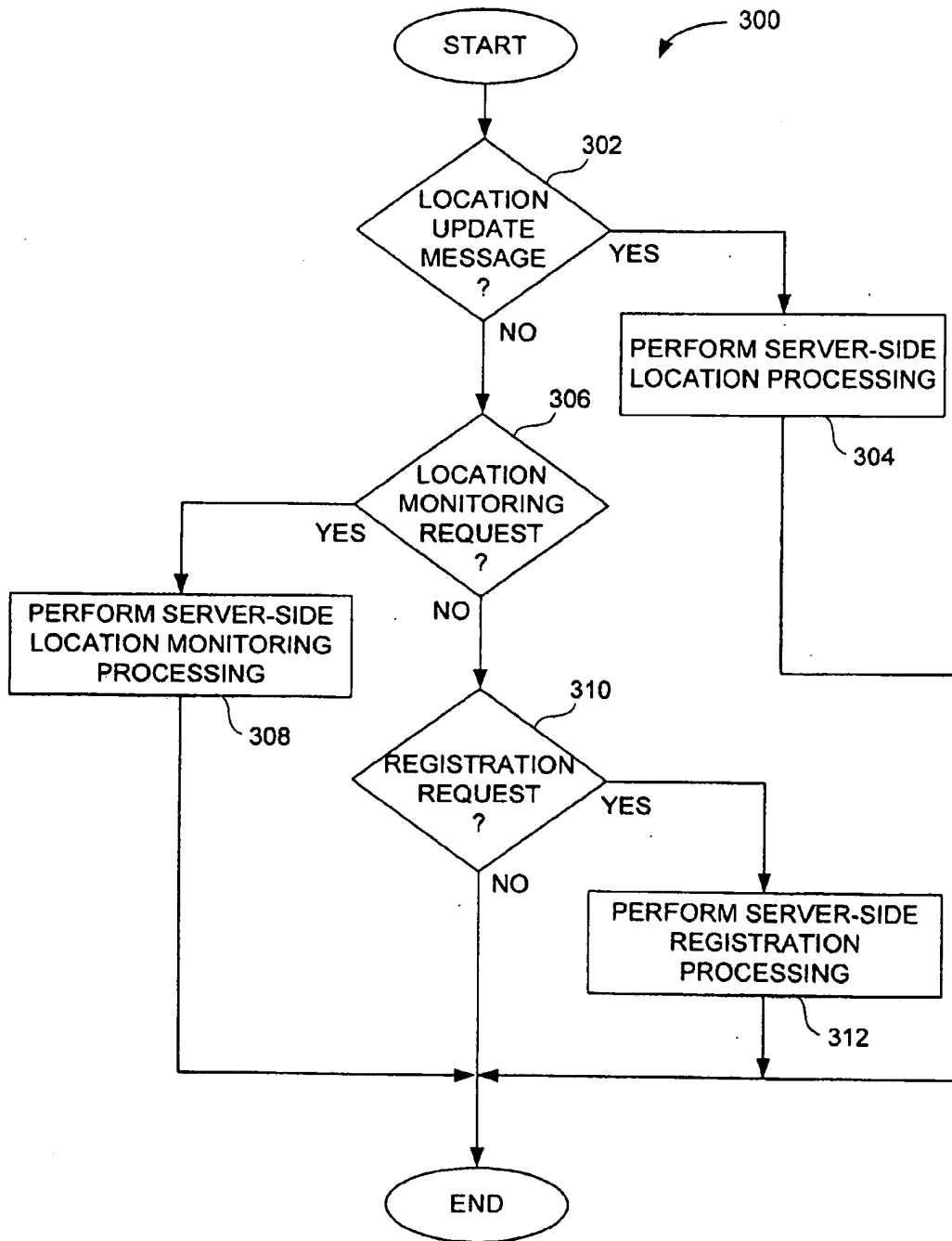

FIG. 3

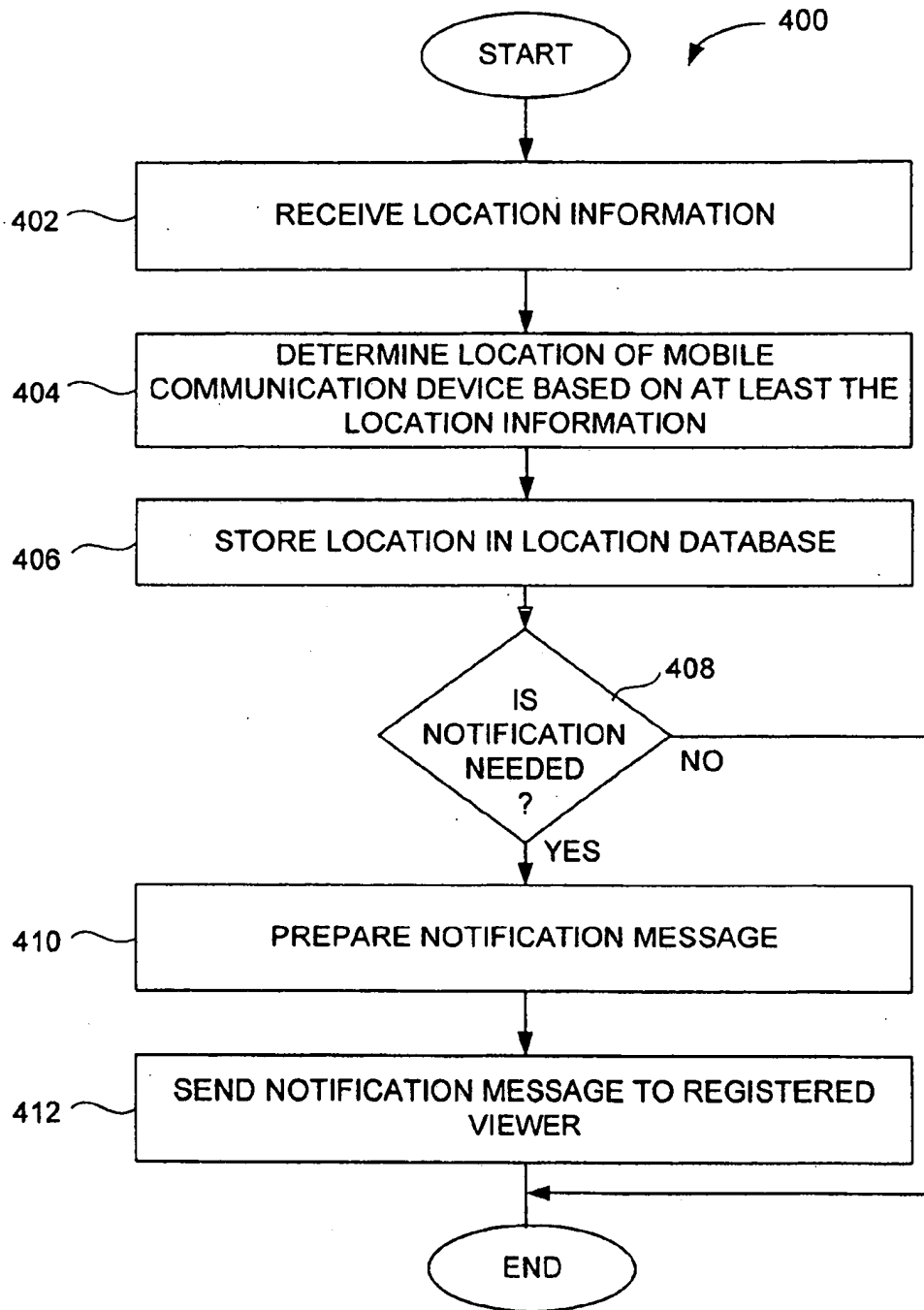

FIG. 4

500

MD	USER	SUPERVISOR	PASSWORD	LOGGED_IN
1	John	Barb	1234	1
2	Jane	Bill	5678	0

FIG. 5A

550

MD	CURRENT LOCATION	PREVIOUS LOCATION
1	XXX	YYY
2	WWW	ZZZ

FIG. 5B

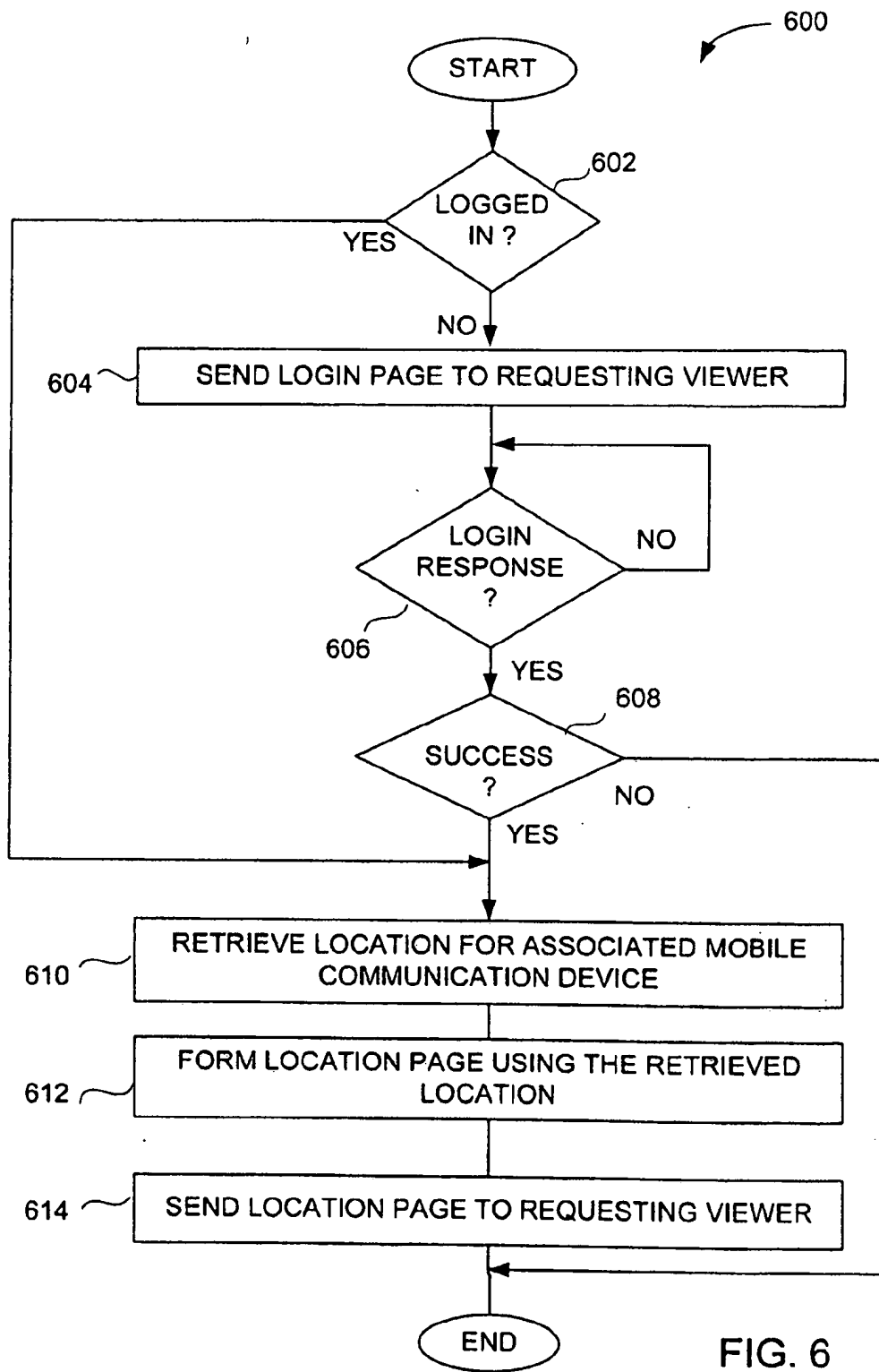
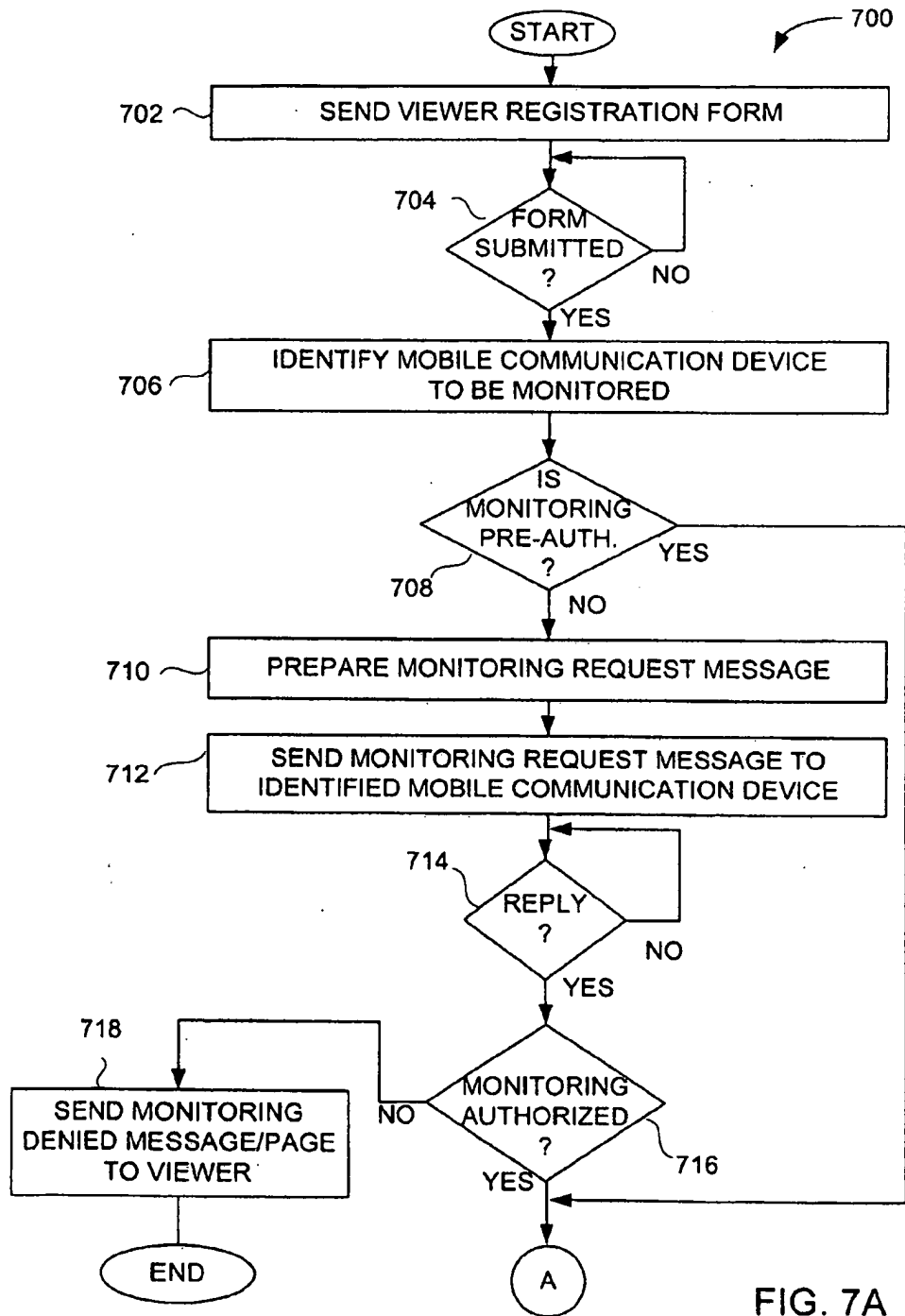

FIG. 6





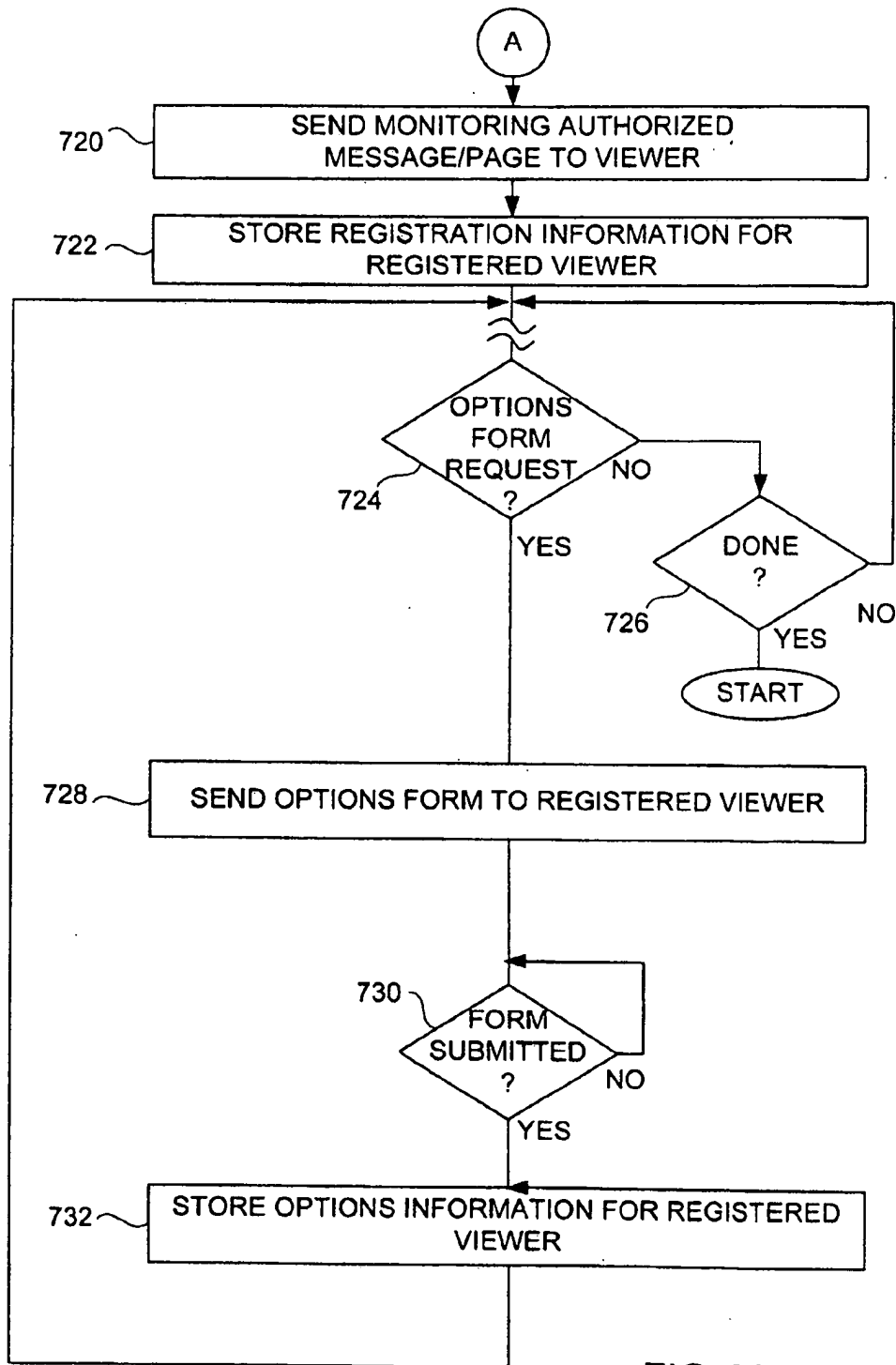

FIG. 7B

1

## METHOD AND SYSTEM FOR LOCATION TRACKING

### CROSS-REFERENCE TO RELATED APPLICATION

This application is a continuation of U.S. patent application Ser. No. 09/797,517, filed Feb. 28, 2001 entitled "METHOD AND SYSTEM FOR LOCATION TRACKING", which is hereby incorporated by reference herein, and which application claims the benefit of U.S. Provisional Patent Application No. 60/185,480, filed Feb. 28, 2000, and entitled "METHOD AND SYSTEM FOR LOCATION TRACKING", which is hereby incorporated by reference herein.

### BACKGROUND OF THE INVENTION

#### 1. Field of the Invention

The present invention relates to computing or communication devices and, more particularly, to location tracking of computing or communication devices.

#### 2. Description of the Related Art

Today, various types of or computing devices having communication capabilities (e.g., wireless communication devices) are available. Examples of computing devices having communication capabilities include pagers, mobile phones, personal digital assistants (PDAs), palm-top computers, and electronic schedulers.

Recently, computing devices have been able to detect their location through Global Positioning Satellites (GPS) or with the assistance of a network (e.g., cellular network). As an example, U.S. Pat. No. 5,959,557 describes a system in which a GPS receiver is used to measure a position of a mobile unit (i.e., vehicle), and reports the position on a map. However, such conventional approaches do not allow for control and general utilization of the position information.

Thus, there is a need for ways to utilize position information of mobile computing devices.

### SUMMARY OF THE INVENTION

Broadly speaking, the invention relates to techniques for location tracking, location utilization, and dissemination and management of location information.

The invention can be implemented in numerous ways including, a method, system, device, and a computer readable medium. Several embodiments of the invention are discussed below.

As a location monitoring system, one embodiment of the invention can, for example, include at least: a plurality of mobile computing devices supported by a wireless network, each of the mobile computing devices being associated with and proximate to an object whose location is being monitored; and a web server coupled to a wired network that couples to the wireless network, the web server storing a plurality of locations of each of the mobile computing devices and enabling authorized users to access the locations of each of the mobile computing devices via the wired network.

As a method for monitoring position of objects, one embodiment of the invention can, for example, include at least the acts of: affixing a mobile computing device to an object to be monitored; periodically activating at least a portion of the mobile computing device to determine its location; subsequently transmitting the location to a web server through at least in part a wireless network; and displaying the

2

location of the object to a monitoring party via the monitoring parties access to the web server.

As a method for monitoring position of a plurality of objects, each of the objects being or having a mobile computing device proximate thereto, one embodiment of the invention can, for example, include: obtaining locations for the mobile computing devices and thus the objects proximate thereto; receiving a request to view the location pertaining to a particular one or more of the objects; and delivering a response to the request, the response including the location pertaining to the particular one or more of the objects.

As a method for monitoring position of a plurality of objects, each of the objects being or having a mobile computing device proximate thereto, one embodiment of the invention can, for example, include at least the acts of: obtaining locations for the mobile computing devices and thus the objects proximate thereto; comparing the locations against at least one predetermined location criteria; and sending an electronic notification to a predetermined destination based on the comparing.

As a location monitoring system, one embodiment of the invention can, for example, include at least: a plurality of mobile computing devices supported by a wireless network, each of the mobile computing devices being associated with and proximate to a corresponding object; and a web server operatively connectable to the wireless network, the web server storing locations of each of the mobile computing devices, and the web server enabling authorized users to access the locations of the mobile computing devices. The authorized users need not be proximate to the objects whose locations they are authorized to access. The web server can determine whether an electronic notification is to be sent to an authorized user based on the location of at least one of the mobile computing devices corresponding to an object. The web server can send an electronic notification to the authorized user when it has been determined that an electronic notification is to be sent to the authorized user. The one or more notification locations can be defined by the authorized user through interaction with the web server, and the one or more notification locations that have been defined can be assigned location labels by the authorized user through interaction with the web server. The location labels assigned by the authorized user can also be personal to the authorized user. The web server can determine whether the location of the mobile computing device corresponding to the object is at one of the one or more notification locations, and can generate the electronic notification when it is determined that the location of the mobile computing device is at one of the notification locations.

As a computer readable medium including at least executable computer program code tangibly stored thereon for monitoring position of objects, each object having a mobile electronic device corresponding thereto, the mobile electronic devices capable of communicating in a wireless manner, one embodiment of the invention can, for example, include at least: computer program code for receiving a location of an object at a server via a wireless network, the location being determined using the mobile electronic device corresponding to the object; computer program code for determining whether the location of the mobile electronic device corresponding to the object is at one of one or more notification locations; computer program code for determining whether a notification is to be sent to an authorized party based on the location of the mobile electronic device corresponding to the object being at one of one or more notification locations; and computer program code for sending the notification to the authorized party when it has been determined

3

that a notification is to be sent to the authorized party. At least one of the one or more notification locations can be defined by an interested party through interaction with the server, and at least one of the one or more notification locations that have been defined can be assigned a location label by the interested party through interaction with the server.

As a method for monitoring position of objects, each object having a mobile computing device provided therewith, the mobile computing devices capable of communicating over a wireless network, one embodiment of the invention can, for example, include: defining, by a monitoring party through interaction with a web server, one or more notification locations; assigning, by the monitoring party through interaction with the web server, location labels to the one or more notification locations that have been defined; receiving, at the web server via the wireless network, a location of the mobile computing device corresponding to the object; determining whether a notification is to be sent to an authorized party based on (i) the location of the mobile computing device corresponding to the object, and (ii) the one or more notification locations; and sending a notification to the authorized party when it has been determined that a notification is to be sent to the authorized party.

Other aspects and advantages of the invention will become apparent from the following detailed description taken in conjunction with the accompanying drawings which illustrate, by way of example, the principles of the invention.

#### BRIEF DESCRIPTION OF THE DRAWINGS

The invention will be readily understood by the following detailed description in conjunction with the accompanying drawings, wherein like reference numerals designate like structural elements, and in which:

FIG. 1 is a block diagram of location monitoring system according to one embodiment of the invention;

FIG. 2 is a flow diagram of client-side location processing according to one embodiment of the invention;

FIG. 3 is a flow diagram of server-side location management processing according to one embodiment of the invention;

FIG. 4 is a flow diagram of server-side location processing according to one embodiment of the invention;

FIG. 5A is a diagram of an exemplary authorization table in a location database;

FIG. 5B is a diagram of an exemplary location table in a location database;

FIG. 6 is a flow diagram of server-side location monitoring processing; and

FIGS. 7A and 7B are flow diagrams of server-side registration processing.

#### DETAILED DESCRIPTION OF THE INVENTION

The invention pertains to techniques for location tracking, location utilization, and dissemination and management of location information.

Embodiments of this aspect of the invention are discussed below with reference to FIGS. 1-7B. However, those skilled in the art will readily appreciate that the detailed description given herein with respect to these figures is for explanatory purposes as the invention extends beyond these limited embodiments.

FIG. 1 is a block diagram of location monitoring system 100 according to one embodiment of the invention. A location monitoring server 102 manages location information pertaining to a plurality of mobile units 104. The mobile units are

4

typically attached to objects, such as people, vehicles, or containers. A wireless network 106 enables the mobile units 104 to communicate with the location monitor server 102. In one embodiment, the wireless network 106 couples to the Internet 108 (or other data network). The location monitoring server 102 also couples to the Internet 108. Location information associated with the mobile units 104 is thus able to be delivered to the location monitoring server 102 through the wireless network 106 and the Internet 108. A location database 110 coupled to the location monitoring server 102 can store the location information for the mobile units 104. The location monitoring server 102 is then able to utilize the location information by accessing the data stored in the location database 110. The location database 110 can reside on the location monitoring server or a separate local or remote computer.

The location monitoring system 100 can also include remote computers 112 and 114 that can couple to the Internet 108 through various means. Once coupled to the Internet 108, the remote computers 112 and 114 can access the location monitoring server 102 to receive location related services or to otherwise make use of the location information.

Each mobile unit can obtain location information on its location and forward the location information to the location monitoring server (web server). The location information can be forwarded to the location monitoring server by a variety of ways. One way is through use of a Short Message Service (SMS) message. The location information can also be obtained by a variety of methods. One method is to provide a Global Positioning Satellite (GPS) device within the mobile units. With GPS, the location information obtained can be distances to a plurality of global positioning satellites or can be a determined location from processing of the distances. When only the distances are provided, then the mobile unit merely sends the distances and need not perform processing to determine the location from the distances (instead a server can do so). Another method is to use location information obtained from a wireless network. With this method, the wireless network can provide location information on some or all of said mobile computing devices to the location monitoring server. In this case, the mobile units need not participate in obtaining the location information. As yet another method, a combination of these or other methods can be used to gather an accurate location for the mobile devices. For example, the location monitoring server could be provided with location information provided from the wireless network as well as location information provided by the mobile units themselves. By using the location information from both sources, more accurate and reliable location determination is able to be performed.

FIG. 2 is a flow diagram of client-side location processing 200 according to one embodiment of the invention. The client-side location processing 200 is performed on a client device, such as the mobile units 104 illustrated in FIG. 1.

The client-side location processing 200 initially powers-up 204 the location detection hardware within the client device. Next, the current location of the mobile communication device (client device) is determined 206. A decision 208 then determines whether the current location (CL) is greater than the previous location (PL) by more than a delta amount ( $\Delta$ ). When the decision 208 determines that the current location is not greater than the previous location by more than the delta amount, the current location is sent 208 to the location monitoring server. Here, the current location can be sent to the location monitoring server in a variety of different electronic ways. These ways include email, file transfer, etc. Then, the previous location is set 210 equal to the current location.

5

Following the operation 210, as well as directly following the decision 208 when the current location does not exceed the previous location by more than the delta amount, the location detection hardware within the mobile communication devices is powered-down 212. Following the operation 212 the client-side location processing 200 is complete and ends.

According to this embodiment, the client device powers up to send its current location to a location monitoring server and then powers down to conserve power usage. In the embodiment shown in FIG. 2, the current location is sent to the location monitoring server only when it differs from the previous location by more than a predetermined amount. This conserves not only network bandwidth but also power usage at the client device.

Alternatively, the new location could be determined and/or sent only after a sensor internal to the client device (mobile unit) indicates that it has undergone significant movement since the previous location was obtained. A wide variety of sensors can be used. For example, motion sensors are readily available that indicate distances walked or run. Using such a sensor would reduce the frequency with which the new location should be determined and/or transmitted, thus saving network bandwidth and conserving power consumption. Such a motion sensor can be built into the client device, then if minimal motion detected, then no location detection need be triggered (or triggered less frequently). This provides automatic shut down of circuitry within the client device when the client device is not moving, in the evening (e.g., user sleeping), in a meeting, in one's office at work, etc.

As another alternative, invoking of the client-side location processing 200 can be performed periodically in accordance with a predetermined period. The predetermined period for the periodic location determination can vary with time of day and day of week. For example, the location determination can be made more frequently during the day and less frequently in the evening. As a further example, different predetermined period can be assigned for different days of the week.

As still another alternative, the client-side location processing 200 can be invoked only when a thermal sensor provided with the client device indicates that the mobile device is being worn by its user. Here, the thermal sensor could be utilized to effectively turn off the location monitoring or transmission circuitry and thus conserve power when the client device is not being worn by its user.

As yet still another alternative, the location monitoring server or some other server could send a request for location information to a client device and thus invoke the acquisition of the current location on the client device. In this regard, the request for the location information could be sent to the client devices only when such information is being remotely monitored by another. Such techniques would also facilitate conservation of power utilization on the client device as well as network bandwidth.

The determination of the location of the client device can thus be triggered or invoked by the client device itself or a location monitoring server (or other remote server) using any of a variety of ways (used separately or in combination). The location of the client device (mobile device) can be determined by the client device itself (e.g., using GPS), by a wireless network infrastructure, or through a combination of both.

FIG. 3 is a flow diagram of server-side location management processing 300 according to one embodiment of the invention. The server-side location management processing 300 begins with a decision 302 that determines whether a location update message has been received. Here, the location update message is a message being sent to the location moni-

6

toring server by a particular one of the mobile units. When the decision 302 determines that a location update message has been received, then server-side location processing is performed 304. The server-side location processing is able to determine the location of the mobile unit (mobile communication device) and store the location into a location database, such as the location database 110 as illustrated in FIG. 1. Additionally, the server-side location processing can notify interested registered viewers. Additional information on the server-side location processing is discussed below with respect to FIG. 4.

On the other hand, when the decision 302 determines that a location update message has not been received, then a decision 306 determines whether a location monitoring request has been received. When the decision 306 determines that a location monitoring request has been received, server-side location monitoring processing is performed 308. As an example, a location monitoring request is received by remote computer, such as one of the computers 112 and 114 illustrated in FIG. 1. The server-side location monitoring processing is able to provide viewers (e.g., registered viewers at the remote computers) with location or position of the one or more mobile units (or associated objects) of interest. The server-side location monitoring processing is further discussed below with respect to FIG. 6.

Alternatively, when the decision 306 determines that a location monitoring request has not been received, then a decision 310 determines whether a registration request has been received. Typically, the registration request would be received at the location monitoring server and would have been sent by one of the remote computers 112 or 114 (or their users). In any case, when the decision determines that a registration request has been received, server-side registration processing is performed 312. The server-side registration processing generally operates to register a user, or the user's computer, for use with the location monitoring system such that location information is able to be accessed and viewed on the viewer's computer. In this regard, various features provide for the mobile users to control who is able to view their location, as well as to send alerts or notifications to authorized registered viewers when certain location-based events occur. Additional details on the server-side registration processing are discussed below with respect to FIGS. 7A and 7B.

Following the operations 304, 308 and 312, the server-side location management processing 300 is complete and ends. However, the server-side location management processing 300 is effectively invoked when an incoming message or request is received at the location monitoring server.

Although not shown in FIG. 3, when a location monitoring request is received from a monitoring party, prior to performing the server-side location monitoring processing, the monitoring party must login with an appropriate user name and/or password. This allows restricted access to the location information. In one embodiment, the users of the mobile units can control whether monitoring parties are given access to their location information by authorizing certain monitoring parties.

FIG. 4 is a flow diagram of server-side location processing 400 according to one embodiment of the invention.

The server-side location processing 400 is, for example, performed by a location monitoring server, such as the location monitoring server 102 illustrated in FIG. 1. The server-side location processing 400 initially receives 402 location information. Typically, the location information is received from a mobile communication device (mobile unit) and/or a carrier network (e.g., wireless network). Next, the location of the mobile communication device is determined 404 based on

at least the location information. Here, the location information could itself be sufficient to enable the determination of the location of the mobile communication device. Alternatively, the location information could be combined with other information in order to determine the location of the mobile communication device (or to more accurately determine the location of the mobile communication device). In another embodiment, the location information could actually indicate the location. In any case, once the location of the mobile communication device has been determined 404, the location is stored 406 in a location database. As an example, the location database can be the location database 110 illustrated in FIG. 1.

Next, a decision 408 determines whether a notification is needed. Here, the server-side location processing 400 is able to send notifications to registered viewers as appropriate. The decision 408 determines whether a notification is needed to inform one or more registered viewers about the location information that has just been received and processed. Hence, when the decision 408 determines that a notification is needed, a notification message is prepared 410. Then, the notification message is sent 412 to the one or more appropriate registered viewers. Following the operation 412, as well as directly following the decision 408 when no notifications are needed, the server-side location processing 400 is complete and ends.

As noted above, the server-side location processing 400 includes the decision 408 that determines whether any notification is needed. Here, based on the location of the mobile communication device, various notifications can be initiated. The various notifications can, for example, alert of a predetermined location, alert of an unauthorized region, alert of change in location, etc. The notification can be sent to the monitoring party through an email message (including two-way pager message), an instant response web-based message, through a web page provided at the mobile communication device, telephone message, and the like.

FIG. 5A is a diagram of an exemplary authorization table 500 in a location database. The exemplary authorization table 500 includes a row of information for each mobile device being monitored. Each row contains information on: mobile device identifier, user, supervisor (monitoring party), password, and whether logged in.

FIG. 5B is a diagram of an exemplary location table 550 in a location database. The exemplary location table 550 includes a row of location information for each of the mobile devices being monitored. Each row contains information on: mobile device identifier, current location, and previous location. The location can include much more historical information to keep a log of the locations of the mobile device over an extended period of time (e.g., day, week, month, year).

FIG. 6 is a flow diagram of server-side location monitoring processing 600 according to one embodiment of the invention. The server-side location monitoring processing 600 begins with a decision 602 that determines whether a requesting viewer (monitoring party) has logged-in. Here, typically a request is received from a requesting viewer that seeks to either to log-in or to receive a location page. Hence, the decision 602 initially determines whether the requesting viewer is logged-in. When the decision 602 determines that the requesting viewer is not yet logged-in, then a log-in page is sent 604 to the requesting viewer. Then, a decision 606 waits for a log-in response. When the decision 606 determines that a log-in response has not yet been received, the server-side location monitoring processing 600 effectively awaits a log-in response (or a suitable time-out). Once the decision 606 determines that a log-in response has been received, then

a decision 608 determines whether the log-in is successful. When the decision 608 determines that the log-in is not successful, then the server-side location monitoring processing 600 is complete and ends with the requesting viewer being denied access to the location related information. On the other hand, when the decision 608 determines that the log-in has been successful, as well as directly following the decision 602 when the requesting viewer is already logged-in, the location for the associated mobile communication device (mobile unit) is retrieved 610. As an example, the location can be retrieved from the location database 110 by the location monitoring server 102 illustrated in FIG. 1. Then, a location page using the retrieved information can be formed 612. Here, the location page represents the formatting of the location information into a suitable format, such as a document, that can be delivered to the requesting viewer. As an example, the location page can be a marked-up language document such as HTML, XML, HDML, or other markup language. The location page can also be customized for the type of computing device being utilized by the requesting viewer. Then, the location page is sent 614 to the requesting user. Following the operation 614, the server-side location monitoring processing 600 is complete and ends with the requesting viewer having received the requested location information.

Following successful login by a requesting viewer (monitoring party), the location for the mobile communication device that the requesting viewer has been authorized to receive is able to be retrieved. Then, the location is provided (i.e., sent) to the requesting viewer. In one embodiment, the location is part of a web page that is sent to the requesting viewer.

A server-side registration processing allows a viewer (requesting viewer) to request to view the location of a particular mobile communication device or its associated object. Access is denied if the viewer is not authorized. In one embodiment, the authorization can be controlled by the owner or user of the particular mobile communication device. The server-side registration processing also allows the viewer to set options. The options that can be set are numerous. Examples of the options include notifications or alerts, type of alert or notification (phone, pager, email, etc.), unauthorized or authorized locations, save history or not, labels for different locations (e.g., home, school, work, etc.). By saving the history (i.e., location history), the viewer is able to subsequently examine a history of movement. The history of movement can be presented to the viewer in textual or graphical formats.

FIGS. 7A and 7B are flow diagrams of server-side registration processing 700 according to one embodiment of the invention. The server-side registration processing is, for example, performed by the location monitoring server 102 illustrated in FIG. 1.

The server-side registration processing 700 initially sends 702 a viewer registration form to a user attempting to register with the location monitoring server. As an example, the viewer registration form can be delivered to a computer associated with the user over the Internet and be displayed in a browser application associated with the user's computer. After the viewer registration form has been sent 702 to the viewer, a decision 704 determines whether the registration form has been submitted. Here, the server-side registration processing 700 is awaiting the return of the viewer registration form. When the decision 704 determines that the viewer registration form has not been returned, then the server-side registration processing 700 awaits its submission. On the other hand, when the decision 704 determines that the viewer registration form has been submitted (or times-out), then the

mobile communication device to be monitored is identified 706. The mobile communication device to be monitored can be identified 706 from the information provided in the viewer registration form or from other information obtained from the viewer (e.g., from a separate page or form submitted by the viewer).

Next, a decision 708 determines whether monitoring of the particular mobile communication device has been pre-authorized. When the decision 708 determines that the monitoring for the particular mobile communication device has not been pre-authorized, then a monitoring request message is prepared 710. The monitoring request message is then sent 712 to the particular mobile communication device identified 706. At this point, the server-side registration processing 700 is effectively waiting for a reply from the particular mobile communication device or its user as to whether or not the requested monitoring is authorized. When a decision 714 receives a reply to the request for authorization, then a decision 716 determines whether the reply has authorized monitoring. When the decision 716 determines that monitoring has not been authorized (i.e., monitoring has been denied) then a monitoring denied message/page is sent 718 to the viewer. Thereafter, a server-side registration processing 700 is complete and ends.

Following the decision 716 when the monitoring has been authorized, as well as directly following the decision 708 when the monitoring has been pre-authorized, a monitoring authorized message/page is sent 720 to the viewer. The monitoring authorized message/page informs the viewer that the requested monitoring of the particular mobile communication device or its associated object has been approved. Then, registration information for the registered viewer is stored 722.

Thereafter, whenever a registered user desires to set options with respect to the manner in which they monitor location of mobile communication devices or its associated object, such registered viewers can complete and submit an options form. Hence, a decision 724 determines whether an options form request has been received. When the decision 724 determines that an options form request has not been received, then a decision 726 determines whether the server-side registration processing 700 is complete. When the decision 726 determines that the registration is complete (done), then the server-side registration processing 700 is complete and ends. On the other hand, when the decision 726 determines that the server-side registration processing 700 is not complete, then the server-side registration processing 700 returns to repeat the operations following the operation 722.

Alternatively, when the decision 724 determines that an options form request has been received, then an options form is sent 728 to the registered viewer. Then, a decision 730 determines whether the options form has been submitted. When the decision 730 determines that the options form has not yet been submitted, then the server-side registration processing 700 awaits submission of such a form. When a decision 730 determines that the options form has been submitted, then the options information provided by the options form is stored 732 for the registered viewer. Following the operation 732, the server-side registration processing 700 returns to repeat the operations following the operation 722.

It should be noted that the server-side registration processing 700 need not wait for the form submission at operations 704 or 730, or the reply message at operation 714, but can instead utilize a database or other data store to store state information such that the server-side registration processing 700 can proceed efficiently without being blocked or held-up while waiting for feedback from viewers or users of mobile

communication devices. Such is well known in the programming fields, particularly with Internet programming.

Still further the invention is suitable for tracking delivery or maintenance personnel or vehicles. When a delivery or service appointment is made, you can receive a code for the truck or person that is going perform the delivery or service. Then, on the delivery day (days) when the truck or person is to deliver to or service one's home or business, an alert message or notification can be sent to the requestor (e.g., home owner or office manager). As examples, the message or notification is electronic and include a page, email or telephone type messages or notifications. Hence, if the homeowner is impatiently waiting for the delivery, they can access the location of the truck or person that is to perform the delivery or service. Still further, the requestor may also obtain schedule information on the person or vehicle, and thus determine how many other are scheduled before you. The schedule could also be updated by the truck or person (or their business) to reflect an up-to-date version through out their day. Hence, the requestor is able to obtain additional information over the Internet without have to wait impatiently or having to phone the associated business for information.

The mobile unit (client device, mobile communications device or mobile computing device) is, for example, one of a pager, mobile phone, personal digital assistant, or reduced size portable computing device.

U.S. Pat. No. 5,959,557 is hereby incorporated herein by reference.

The invention can, at least partly, be embodied as computer readable code (computer readable program code) on a computer readable medium. The computer readable medium is any data storage device that can store data which can be thereafter be read by a computer system. Examples of the computer readable medium include read-only memory, random-access memory, CD-ROMs, magnetic tape, and optical data storage devices. The computer readable medium can also be distributed over a network coupled computer systems so that the computer readable code is stored and executed in a distributed fashion.

The advantages of the invention are numerous. Different embodiments or implementations may yield one or more of the following advantages. One advantage of the invention is that location of objects can be tracked via the Internet. Another advantage of the invention is that objects, such as persons, can control the dissemination of their location information. Another advantage of the invention is that alerts or notification can be triggered based on locations of objects. Another advantage of the invention is that mobile computing devices providing location monitoring capabilities are small (e.g., wearable) and offer low power consumption (e.g., long battery life). Another advantage of the invention is that embodiments can operate without user input or actions.

The many features and advantages of the present invention are apparent from the written description and, thus, it is intended by the appended claims to cover all such features and advantages of the invention. Further, since numerous modifications and changes will readily occur to those skilled in the art, it is not desired to limit the invention to the exact construction and operation as illustrated and described. Hence, all suitable modifications and equivalents may be resorted to as falling within the scope of the invention.

The invention claimed is:

1. A location monitoring system, comprising:
  - one or more mobile electronic devices supported by a wireless network, each of said mobile electronic devices being associated with and proximate to a corresponding object; and

11

a computer configured to store locations of each of said mobile electronic devices, and said computer enabling authorized users to access the locations of said mobile electronic devices,  
 wherein the authorized users do not have to be proximate to the objects whose locations they are authorized to access,  
 wherein said computer determines whether notification should be sent to an authorized user based on the location of a mobile electronic device corresponding to an object, the mobile electronic device being one of said mobile electronic devices,  
 wherein said computer sends an electronic notification to the authorized user when it has been determined that notification should be sent to the authorized user,  
 wherein one or more notification locations are defined for the authorized user through interaction with said computer, and wherein at least one of the one or more notification locations is assigned a location label by the authorized user through interaction with said computer,  
 wherein the location label assigned by the authorized user is personal to the authorized user, and  
 wherein said computer determines whether the location of the mobile electronic device corresponding to the object is at one of the one or more notification locations, and generates the electronic notification when it is determined that the location of the mobile electronic device is at one of the notification locations.

2. A location monitoring system as recited in claim 1, wherein each of said mobile electronic devices operates to obtain location information of its location and to wirelessly forward the location information to said computer.

3. A location monitoring system as recited in claim 1, wherein the object is a person, a vehicle or a package.

4. A location monitoring system as recited in claim 1, wherein the electronic notification is an electronic message, and  
 wherein the electronic message is automatically transmitted to the authorized user when it is determined that the location of the mobile electronic device is at one of the notification locations.

5. A location monitoring system as recited in claim 1, wherein a requestor requests that said computer provide the location of the object, and  
 wherein, when a requestor requests that said computer provide the location of the object, said computer returns a response to the requestor, the response including the location of the object based on the location of the corresponding mobile electronic device.

6. A location monitoring system as recited in claim 1, wherein the authorized user must be registered with said computer before the authorized user is authorized to access the location of one or more of said mobile electronic devices,  
 wherein at least one attribute of the electronic notification can depend on information provided by the authorized user during the registration of the authorized user, and  
 wherein the information provided by the authorized user during registration includes at least one notification condition.

7. A location monitoring system as recited in claim 6, wherein the at least one notification condition specifies a type of notification or how often notification is to be provided.

8. A location monitoring system as recited in claim 1, wherein access to locations of each of said mobile electronic devices is controlled by owner or user of the corresponding mobile electronic device.

12

9. A location monitoring system as recited in claim 1, wherein said location monitoring system is configured to enable the authorized user to set at least one delivery criterion regarding electronic notifications to be provided.

10. A location monitoring system as recited in claim 1, wherein the mobile electronic device is a mobile phone.

11. A location monitoring system as recited in claim 10, wherein said computer maintains a history of locations of the mobile device, and wherein said computer is configured to present the history of locations to the authorized party in at least a graphical form.

12. A location monitoring system as recited in claim 10, wherein the object is a person, and wherein the mobile phone is available for use by the person.

13. A location monitoring system as recited in claim 12, wherein the electronic notification is an electronic message, and  
 wherein the electronic message is automatically transmitted to the authorized user when it is determined that the location of the mobile electronic device is at one of the notification locations.

14. A location monitoring system as recited in claim 13, wherein the notification being sent is an electronic mail or instant message.

15. A location monitoring system as recited in claim 13, wherein said location monitoring system is configured to enable the authorized user to select from a plurality of options regarding electronic notifications to be provided.

16. A location monitoring system as recited in claim 12, wherein access to the location of the mobile phone is controlled by the person via the mobile phone.

17. A location monitoring system as recited in claim 12, wherein said location monitoring system is configured to determine whether the person using the mobile phone has authorized the authorized party to access the location of the mobile phone.

18. A location monitoring system as recited in claim 17, wherein said location monitoring system maintains a history of locations of the mobile phone, and wherein said location monitoring system is configured to present the history of locations to the authorized party in at least a graphical form.

19. A location monitoring system as recited in claim 12, wherein said location monitoring system is configured to restrict access to the location of the mobile phone to only those one or more users that the person using the mobile phone has authorized device is at one of the notification locations.

20. A location monitoring system as recited in claim 12, wherein said location monitoring system is configured to send an access request to the mobile phone to determine if a requestor is allowed to access to the location of the mobile phone, and to receive from the mobile phone an access response to the access request, the access response indicating whether or not the requestor is permitted to access the location of the mobile phone.

21. A location monitoring system as recited in claim 12, wherein said location monitoring system comprises a web server, and  
 wherein the authorized user is able to log into the web server to gain access to one or more locations of the mobile phone.

22. A location monitoring system as recited in claim 12, wherein said location monitoring system provides an electronic notification to the mobile phone, the electronic notification indicating that the location of the mobile device is being monitored.



13

23. A non-transitory computer readable medium including at least executable computer program code tangibly stored thereon for monitoring position of one or more objects using one or more mobile electronic devices, each object having a mobile electronic device corresponding thereto, the one or more mobile electronic devices being capable of communicating in a wireless manner, said computer readable medium comprising:

computer program code for receiving a location of an object at a server via a wireless network, the location being associated with the mobile electronic device corresponding to the object;

computer program code for determining whether the location of the mobile electronic device corresponding to the object is at one of one or more notification locations for which a notification is to be sent to an interested party based on the location of the mobile electronic device corresponding to the object being at one of one or more notification locations; and

computer program code for generating and sending the notification to the interested party when it has been determined that a notification is to be sent to the interested party based on the location of the mobile electronic device corresponding to the object being at one of one or more notification locations; and

computer program code for receiving at least one of the one or more notification locations that has been defined by the interested party through interaction with the server, wherein at least one of the one or more notification locations includes a location label that is for use by the server with respect to the interested party, and wherein the notification sent to the interested party includes the location label when it is determined by said computer code for determining that the location of the mobile electronic device corresponding to the object is at the notification location corresponding to the location label.

24. A computer readable medium as recited in claim 23, wherein access to locations of each of the mobile electronic devices is controlled by owner or user of the corresponding mobile electronic device.

25. A computer readable medium as recited in claim 23, wherein said computer readable medium further comprises: computer program code for providing location data to display the location of the mobile electronic device corresponding to the object to the interested party via accessing the server through the Internet, wherein the interested party does not have to be proximate to the object.

26. A computer readable medium as recited in claim 23, wherein at least one of the one or more notification locations pertains to a predetermined location, wherein said computer program code for determining comprises computer program code for determining whether the location of the mobile electronic device corresponding to the object is at the predetermined location, and wherein said computer program code for generating and sending the notification comprises computer program code for sending the notification when said computer program code for determining determines that the location of the mobile electronic device corresponding to the object is at the predetermined location.

27. A computer readable medium as recited in claim 26, wherein said computer program code for sending the notification operates to send the notification when it is determined that the location of the mobile electronic device has entered the predetermined location.

14

28. A computer readable medium as recited in claim 12, wherein the notification being sent is an electronic mail or instant message.

29. A computer readable medium as recited in claim 23, wherein said computer program code for receiving periodically receives the location of the mobile electronic device, and wherein the period by which said computer program code for receiving operates to receive the location is in accordance with a predetermined schedule, the schedule utilizing a plurality of different periods by which the location is acquired.

30. A computer readable medium as recited in claim 23, wherein said computer program code for receiving periodically receives the location of the mobile electronic device, and wherein the period by which said computer program code for receiving operates to receive the location is different during different times of a day or on different days.

31. A computer readable medium as recited in claim 23, wherein access to locations of each of the mobile electronic devices is controlled by an owner of the corresponding mobile electronic device.

32. A computer readable medium as recited in claim 23, wherein the notification being sent is an electronic mail or instant message.

33. A computer readable medium as recited in claim 23, wherein said computer readable medium comprises:

computer program code for receiving a request for the location of the mobile electronic device corresponding to the object; and

computer program code for returning a response to the request, the response including the location of the mobile electronic device corresponding to the object.

34. A computer readable medium as recited in claim 23, wherein said computer readable medium comprises:

computer program code for receiving a request from a requestor for the location of the mobile electronic device corresponding to the object;

computer program code for determining whether the requestor is authorized to receive the location of the mobile electronic device corresponding to the object; and

computer program code for returning a response to the request if the requestor is determined to be authorized, the response including the location of the mobile electronic device corresponding to the object.

35. A computer readable medium as recited in claim 23, wherein said computer readable medium comprises:

computer program code for receiving a notification condition at the server, the notification condition being associated with the interested party; and

computer program code for determining whether the notification is to be sent to the interested party based on the notification condition.

36. A method for monitoring position of one or more objects using one or more mobile electronic devices, each object having a mobile electronic device provided therewith, the one or more mobile electronic devices being capable of communicating over a wireless network, said method comprising:

receiving at a web server one or more notification locations set by a monitoring party;

receiving at the web server a location label assigned by the monitoring party to at least one of the one or more notification locations;

receiving, at the web server via the wireless network, a location of a mobile electronic device corresponding to an object;

15

determining, at the web server, whether a notification is to be sent to the monitoring party based on (i) the location of the mobile electronic device corresponding to the object, and (ii) the one or more notification locations; and

electronically sending a notification to the monitoring party when it has been determined that a notification is to be sent to the monitoring party,

wherein said determining comprises determining whether the location of the mobile electronic device corresponding to the object is at one of the one or more notification locations, and

wherein said electronically sending comprises (i) generating the notification when said determining determines that the location of the mobile electronic device corresponding to the object is at one of the one or more notification locations, and (ii) sending the notification generated to the monitoring party when said determining determines that the location of the mobile electronic device corresponding to the object is at one of the one or more notification locations,

wherein the notification generated includes at least the location label corresponding to the one of the one or more notification locations where the mobile electronic device corresponding to the object is determined to be located, and

wherein the location label assigned by the monitoring party is for use with respect to the monitoring party, and wherein the notification sent to the monitoring party includes the location label when said determining determines that the location of the mobile electronic device corresponding to the object is at the notification location corresponding to the location label.

37. A method as recited in claim 36, wherein the notification being sent is an electronic message.

38. A method as recited in claim 36, wherein the notification being sent is an electronic text message.

39. A method as recited in claim 36, wherein access to locations of each of the mobile electronic devices is controlled by a user of the corresponding mobile electronic device.

40. A method as recited in claim 36, wherein said method further comprises:

displaying the location of the mobile electronic device corresponding to the object to a requestor via accessing the web server through the Internet,

wherein before the location is displayed to the requestor the monitoring party has to be authorized.

41. A method as recited in claim 36, wherein said receiving of the location periodically receives the location of the mobile electronic device, and wherein the period by which said receiving operates to receive the location of the mobile electronic device is different during different times of a day or on different days.

42. A method as recited in claim 36, wherein at least one of the one or more notification locations pertains to a predetermined location, and

wherein said method comprises:

electronically transmitting a notification that the object is in the predetermined location.

43. A method as recited in claim 42, wherein the notification being sent is an electronic mail or instant message.

44. A method as recited in claim 36,

wherein the object is a person, and

wherein at least one of the one or more notification locations pertains to a predetermined location, and

16

wherein said sending of the notification comprises transmitting a notification indicating that the object has entered the predetermined location.

45. A method for monitoring position of one or more persons using one or more mobile phones, each person having a mobile phone provided therewith, the one or more mobile phones being capable of communicating over a wireless network, said method comprising:

receiving at a server one or more notification locations set by a monitoring party;

receiving at the server one or more notification options requested by the monitoring party;

receiving at the server a location label assigned by the monitoring party to at least one of the one or more notification locations;

receiving a location of a mobile phone corresponding to a person;

determining whether the monitoring party has been authorized to access the location of the mobile phone;

determining whether a notification is to be sent to the monitoring party based on (i) the location of the mobile phone corresponding to the person, (ii) the one or more notification options, (iii) the one or more notification locations, and (iv) whether the monitoring party has been authorized; and

electronically sending a notification to the monitoring party when it has been determined that a notification is to be sent to the monitoring party,

wherein said determining whether a notification is to be sent comprises determining whether the location of the mobile phone corresponding to the person is at one of the one or more notification locations,

wherein said electronically sending comprises (i) generating the notification when said determining whether a notification is to be sent determines that the location of the mobile phone corresponding to the person is at one of the one or more notification locations, and (ii) sending the notification generated to the monitoring party when said determining whether a notification is to be sent determines that the location of the mobile phone corresponding to the person is at one of the one or more notification locations,

wherein the notification generated includes at least the location label corresponding to the one of the one or more notification locations where the mobile phone corresponding to the person is determined to be located, and

wherein the location label assigned by the monitoring party is for use with respect to the monitoring party, and wherein the notification sent to the monitoring party includes the location label when said determining whether a notification is to be sent determines that the location of the mobile phone corresponding to the person is at the notification location corresponding to the location label.

46. A method as recited in claim 45, wherein the notification being sent is an electronic mail or instant message.

47. A method as recited in claim 45, wherein said determining whether the monitoring party has been authorized to access the location of the mobile phone comprises:

sending an access request to the mobile phone to approve a monitoring party's access to the location of the mobile phone; and

receiving from the mobile phone an access response to the access request, the access response indicating whether or not the monitoring party is permitted to access the location of the mobile phone.

17

48. A method as recited in claim 45, wherein said computer comprises a server, and

wherein the monitoring party is able to log into the server to gain access to one or more locations of the mobile phone.

49. A method as recited in claim 45, wherein said method comprises sending an electronic message to the mobile phone, the electronic message indicating that the location of the mobile device is being monitored.

50. A method as recited in claim 45 wherein said receiving of a location of a mobile phone comprises receiving the location of the mobile phone via the wireless network.

51. A method for monitoring position of one or more persons using one or more mobile phones, each person having a mobile phone provided therewith, the one or more mobile phones being capable of communicating over a wireless network, said method comprising:

receiving at a server one or more notification locations set by a monitoring party;

receiving at the server one or more notification options requested by the monitoring party;

receiving at the server a location label assigned by the monitoring party to at least one of the one or more notification locations;

receiving a location of a mobile phone corresponding to a person;

determining whether the monitoring party has been authorized to access the location of the mobile phone;

determining whether a notification is to be sent to the monitoring party based on the one or more notification options requested by the monitoring party, provided that the monitoring party has been authorized; and

electronically sending a notification to the monitoring party when it has been determined that a notification is to be sent to the monitoring party, the notification indicating the location of the mobile phone corresponding to the person,

wherein said electronically sending comprises (i) retrieving the notification generated, and (ii) sending the notification generated to the monitoring party when said determining determines that a notification is to be sent, and wherein the notification being sent is an electronic mail or instant message.

52. A method as recited in claim 51, wherein said determining whether the monitoring party has been authorized to access the location of the mobile phone comprises:

sending an access request to the mobile phone to approve a monitoring party's access to the location of the mobile phone; and

receiving from the mobile phone an access response to the access request, the access response indicating whether or not the monitoring party is permitted to access the location of the mobile phone.

53. A method as recited in claim 51, wherein the monitoring party is able to log into the server to gain access to one or more locations of the mobile phone.

54. A method as recited in claim 51, wherein said method comprises sending an electronic message to the mobile phone, the electronic message indicating that the location of the mobile device is being monitored.

55. A method as recited in claim 51, wherein said receiving a location of a mobile phone comprises receiving the location of the mobile phone via the wireless network.

56. A method as recited in claim 51, wherein the location label assigned by the monitoring party is for use with respect to the monitoring party, and wherein the notification sent to

18

the monitoring party includes the location label when said determining whether a notification is to be sent determines that the location of the mobile phone corresponding to the person is at the notification location corresponding to the location label.

57. A method as recited in claim 51, wherein the one or more notification options are set with respect to the one or more notification locations.

58. A location monitoring system, comprising:

one or more mobile computing devices supported by a wireless network, each of said mobile computing devices being associated with and proximate to a corresponding object; and

a server operatively connectable to the wireless network, said server configured to store locations of each of said mobile computing devices, and said server enabling authorized users to access the locations of said mobile computing devices via the Internet,

wherein the authorized users do not have to be proximate to the objects whose locations they are authorized to access,

wherein said server determines whether an electronic mail or instant message notification is to be sent to an authorized user based on one or more notification options requested by the authorized user,

wherein said server sends an electronic mail or instant message notification to the authorized user when it has been determined that an electronic mail or instant message notification is to be sent to the authorized user, the electronic mail or instant message notification includes at least the location of at least one of said one or more mobile computing devices corresponding to an object, wherein one or more notification locations are defined by the authorized user through interaction with said server, and wherein the one or more notification locations that have been defined are assigned location labels by the authorized user through interaction with the server, and wherein the one or more notification options are defined by the authorized user through interaction with said server.

59. A location monitoring system as recited in claim 58, wherein said server is further configured to determine whether the location of the mobile computing device corresponding to the object is at one of the one or more notification locations, and generate a notification when it is determined that the location of the mobile computing device is at one of the notification locations, and sends the notification to the authorized user.

60. A location monitoring system as recited in claim 58, wherein each of said mobile computing devices operates to obtain location information of its location and to forward the location information to said server.

61. A location monitoring system as recited in claim 58, wherein at least one of the mobile computing devices associated with a corresponding object is a mobile phone, and wherein the corresponding object is a person.

62. A location monitoring system as recited in claim 61, wherein the location monitoring system acquires the location of the person in accordance with a schedule, the schedule utilizing a plurality of different periods to acquire the location.

63. A location monitoring system as recited in claim 58, wherein at least one object corresponding to one of the mobile computing devices is a person, wherein said server is configured to receive a request from an authorized user for the location of the person, and wherein, when an authorized user requests that said server specify the location of the person, said server provides a

19

response to the authorized user, the response including the location of the person based on the location of the corresponding one of said mobile computing devices, the corresponding one of said mobile computing devices being a mobile phone.

64. A location monitoring system as recited in claim 58, wherein at least one of the notification options includes how often a notification is to be provided.

65. A location monitoring system as recited in claim 58, wherein the different periods correspond to different days of the week.

66. A location monitoring system as recited in claim 58, wherein access to locations of at least one of said mobile

20

computing devices is controlled by the owner of the corresponding mobile computing device.

67. A location monitoring system as recited in claim 58, wherein access to locations of at least one of said mobile computing devices is controlled by the user of the corresponding mobile computing device.

68. A location monitoring system as recited in claim 58, wherein said location monitoring system maintains a history of locations of each of said mobile computing devices, and wherein said location monitoring system is configured to present at least a portion of the history of locations of at least one of said one or more corresponding mobile computing devices to the authorized user in at least a graphical form.

\* \* \* \* \*

6

Proietti

U.S. Patent No. 8,755,823



US008755823B2

(12) **United States Patent**  
Proietti et al.

(10) **Patent No.:** US 8,755,823 B2  
(45) **Date of Patent:** Jun. 17, 2014

- (54) **SYSTEM AND METHOD FOR DYNAMICALLY MONITORING STATUS IN LOCATION SERVICES**
- (75) Inventors: **Mario Proietti**, Fullerton, CA (US); **John Thomas Moring**, Encinitas, CA (US); **Brenda C. Schafer**, Carlsbad, CA (US)
- (73) Assignee: **Technocom Corporation**, Encino, CA (US)
- (\* ) Notice: Subject to any disclaimer, the term of this patent is extended or adjusted under 35 U.S.C. 154(b) by 156 days.

2001/0004600	A1 *	6/2001	Son et al. ....	455/456
2003/0078053	A1 *	4/2003	Abtin et al. ....	455/456
2004/0127229	A1 *	7/2004	Ishii .....	455/456.1
2005/0032532	A1 *	2/2005	Kokkonen et al. ....	455/456.6
2005/0085257	A1 *	4/2005	Laird et al. ....	455/550.1
2005/0143096	A1 *	6/2005	Boesch .....	455/456.3
2006/0046744	A1 *	3/2006	Dublish et al. ....	455/456.3
2006/0055528	A1 *	3/2006	Akamatsu .....	340/531
2007/0159322	A1 *	7/2007	Garratt Campbell ....	340/539.13
2007/0178908	A1 *	8/2007	Doyle .....	455/456.1
2007/0182546	A1 *	8/2007	Virk et al. ....	340/539.13
2007/0194938	A1 *	8/2007	Mitchell .....	340/573.1
2007/0287428	A1 *	12/2007	Diacakis et al. ....	455/414.1
2010/0255856	A1 *	10/2010	Kansal et al. ....	455/456.1
2012/0276927	A1 *	11/2012	Pitt .....	455/456.2

- (21) Appl. No.: **13/028,060**
- (22) Filed: **Feb. 15, 2011**
- (65) **Prior Publication Data**  
US 2012/0208550 A1 Aug. 16, 2012
- (51) **Int. Cl.**  
*H04W 24/00* (2009.01)
- (52) **U.S. Cl.**  
USPC ..... 455/456.2; 455/414.1; 340/539.13
- (58) **Field of Classification Search**  
CPC ..... G01S 5/0027; H04W 8/18; H04W 12/02; H04W 24/00; H04W 64/00  
USPC ..... 455/456.1-456.5, 414.1; 340/539.13  
See application file for complete search history.

**OTHER PUBLICATIONS**

Sprint, "Workforce Locator 6.1, User's Guide"; Feb. 2011, 31 pp.

\* cited by examiner

*Primary Examiner* — Charles Shedrick  
(74) *Attorney, Agent, or Firm* — Christie, Parker & Hale, LLP

- (56) **References Cited**  
U.S. PATENT DOCUMENTS  
6,363,323 B1 \* 3/2002 Jones ..... 701/468  
6,591,112 B1 \* 7/2003 Siccardo et al. .... 455/521  
7,133,663 B2 \* 11/2006 Fano et al. .... 455/414.1  
7,133,909 B2 \* 11/2006 Bahl ..... 709/223

(57) **ABSTRACT**  
A method and system for reporting a location of an asset. The method includes: receiving a location tracking request for the asset; dynamically determining a status of the asset; and allowing acquisition of the location of the asset based on the determined status. The method further includes: obtaining the location of the asset responsive to the received request and said allowing; and reporting the obtained location of the asset. The system includes: a reporting module for receiving a location tracking request for the asset; a status module for dynamically determining a status of the asset; and a tracking module for obtaining the location of the asset responsive to the determined status. The reporting module reports the location of the asset responsive to the received location tracking request.

**23 Claims, 4 Drawing Sheets**

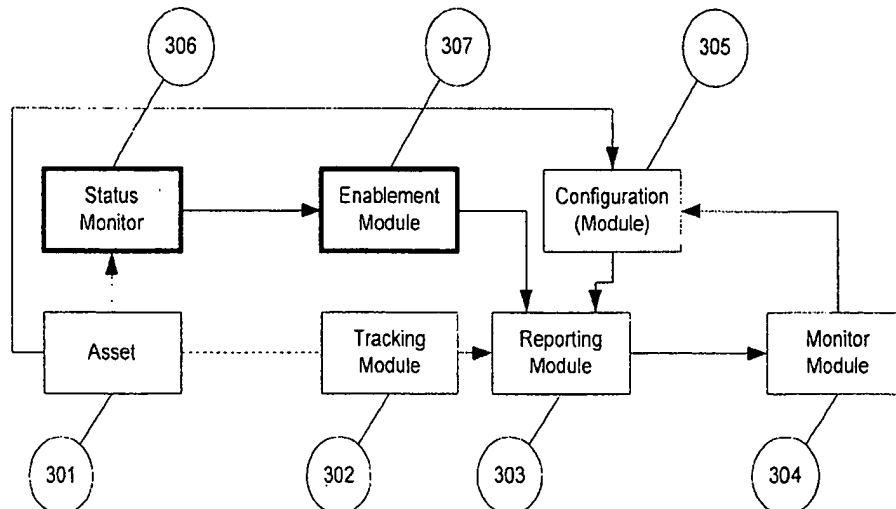

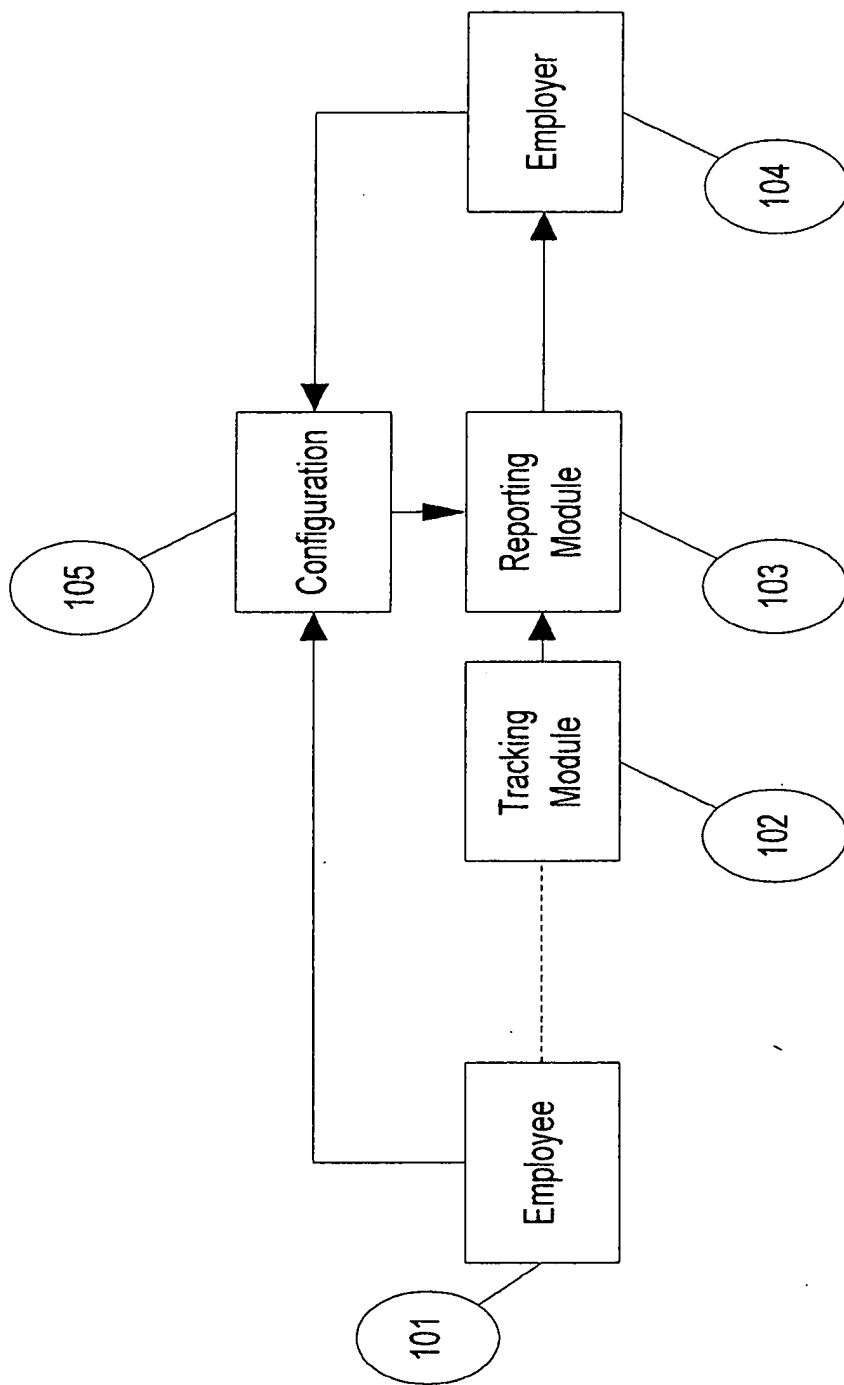

FIG. 1 (PRIOR ART)

Active	<input checked="" type="checkbox"/>
Time Restriction	Start time (HH:MM:SS): 08 : 00 : 00 End time (HH:MM:SS): 17 : 00 : 00
Days:	M <input checked="" type="checkbox"/> Tu. <input checked="" type="checkbox"/> W <input checked="" type="checkbox"/> Th <input checked="" type="checkbox"/> F <input checked="" type="checkbox"/> Sa <input type="checkbox"/> Su <input type="checkbox"/>

FIG. 2 (PRIOR ART)



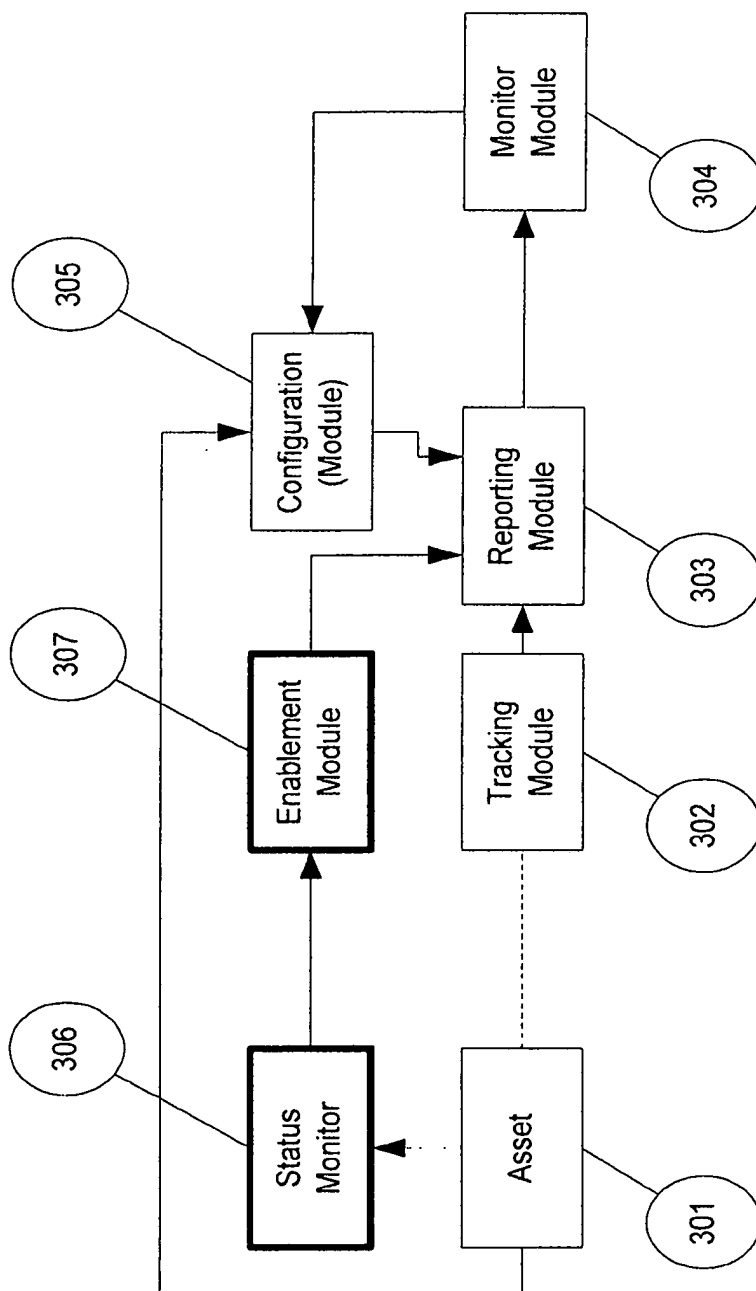

FIG. 3

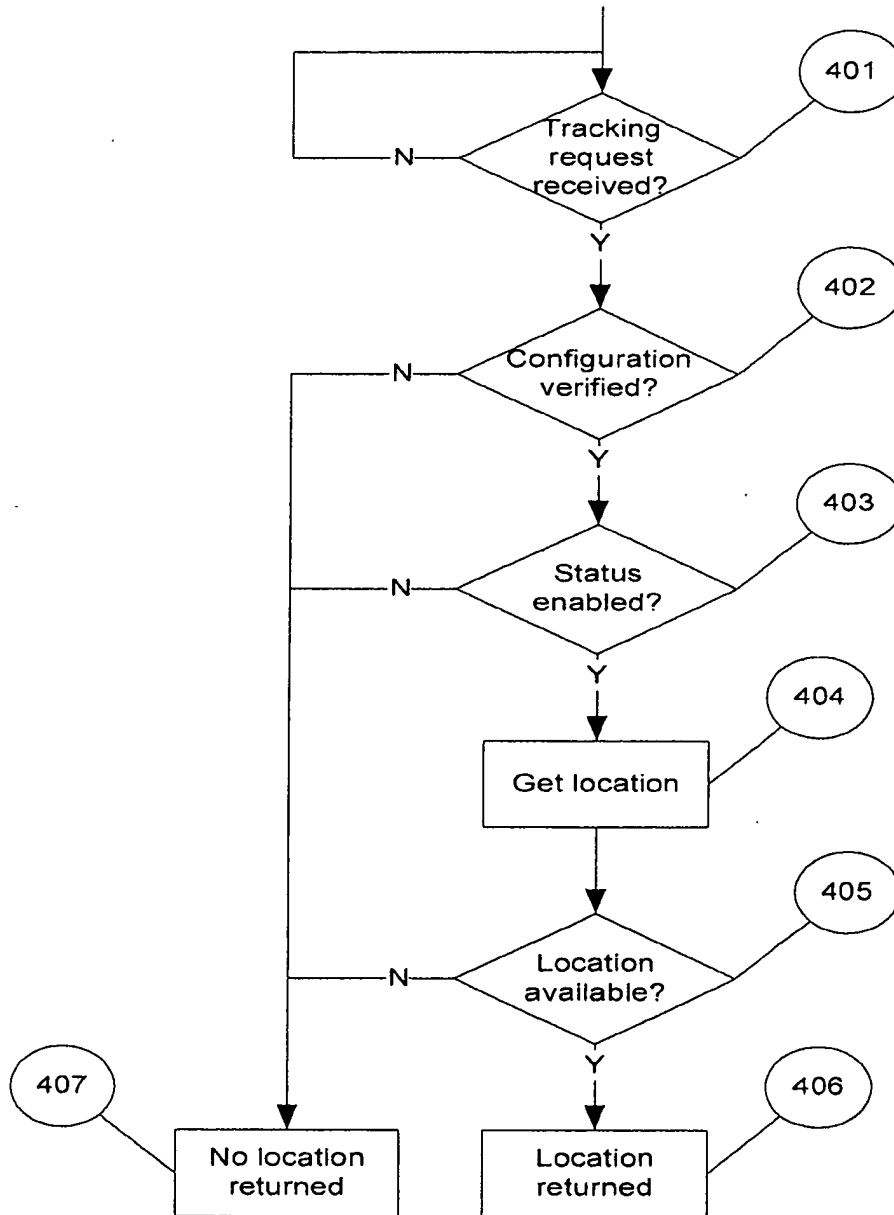

FIG. 4

1

# SYSTEM AND METHOD FOR DYNAMICALLY MONITORING STATUS IN LOCATION SERVICES

## FIELD OF INVENTION

The present invention relates to the field of location based services, and more specifically to a system and method for dynamically monitoring status in location services.

## BACKGROUND

Radiolocation of mobile devices developed in the last half of the 20<sup>th</sup> century, notably with the deployment of the Global Positioning System (GPS). Mobile phone technology evolved in a similar time frame. By the turn of the century, US cellular carriers deployed location-determination technology in their networks in support of emergency (E9-1-1) services. Subsequently, with the widespread use of smart phones and other portable computing devices, numerous applications utilizing location have been made available for such uses as direction finding, tracking individuals, and matching persons with nearby businesses.

Traditionally, a company might monitor its resources, e.g., vehicles, through an expensive specialized tracking system. With location technology being integrated into employees' personal communication equipment (cell phones), the specialized tracking systems may no longer be needed. The employer can track the employees via their cell phones. However, it may be necessary or appropriate for the employer to only track the employee during work hours. A simple "9-10-5, Monday-through-Friday," tracking limitation is not suitable for many workers who may have flexible hours, employees on vacation, etc.

The present invention solves this problem by enabling and disabling location tracking or reporting thereof, based on a dynamically monitored status, for example, when an employee is on the job and when the employee is on his or her own time.

## SUMMARY

In some embodiments, the present invention is a method for reporting a location of an asset. The method includes: receiving a location tracking request for the asset; dynamically determining a status of the asset; and allowing acquisition of the location of the asset based on the determined status. The method further includes: obtaining the location of the asset responsive to the received request and said allowing; and reporting the obtained location of the asset.

In some embodiments, the present invention is a system for reporting a location of an asset. The system includes: a reporting module for receiving a location tracking request for the asset; a status module for dynamically determining a status of the asset; and a tracking module for obtaining the location of the asset responsive to the determined status. The reporting module reports the location of the asset responsive to the received location tracking request.

In some embodiments, the present invention is a method for reporting a location of an asset. The method includes: receiving a first indication of a current state of the person, the current state being one of a plurality of predefined states, wherein the first indication is triggered by a first action of the person; storing information about the current state; determining a first permission based on the information about the current state, the first permission indicating a first level of allowed location reporting; and reporting the location of the

2

person based on the first permission. The method may further include receiving a second indication of an updated current state of the person, the updated current state being one of the plurality of predefined states; wherein the second indication is triggered by a second action of the person; storing information about the updated current state; determining a second permission based on the information about the updated current state, the second permission indicating a second level of allowed location reporting; and reporting the location of the person based on the second permission.

## BRIEF DESCRIPTION OF THE DRAWINGS

FIG. 1 shows a system diagram for tracking an employee, according to the prior art.

FIG. 2 shows a form for entering tracking times, according to the prior art.

FIG. 3 shows an exemplary system diagram for tracking an asset, according to some embodiments of the present invention.

FIG. 4 shows an exemplary logical flow of a reporting module, according to some embodiments of the present invention.

## DETAILED DESCRIPTION

In some embodiments, the present invention enables and/or disables location tracking of an asset or resource, or reporting thereof, based on a dynamically monitored status, for example, when an employee is on the job and/or when the employee is on his or her own time.

FIG. 1 illustrates an exemplary functional block diagram of a typical employee tracking system, according to the prior art. Data flows are indicated by arrowed lines. An employee 101 is monitored by a tracking module 102. The dotted line indicates a location determination, e.g., using the cellular network. The tracking module provides employee locations to a reporting module 103, which in turn make the locations available to an employer 104. An example of this is a cell phone tracking feature provided by a cellular carrier. In this example, the employer pays for the employee cell phone usage, and in turn has permission to monitor employee location while the employee is working. The details are controlled by a configuration module 105, which has information entered by the employer and possibly the employee. Configuration typically includes information such as employee name, mobile device identification, times for employee to be tracked, boundary areas for alerts, etc. The employee may or may not have access to aspects of the configuration.

FIG. 2 illustrates an example of a form used to enter some of the configuration information, according to the prior art. For a given account, the tracking can be made active (allowed) or inactive (disallowed) in the first line. In the second line, the hours of tracking are entered, here from 8 AM to 5 PM. In the third line, the days of tracking are entered, here weekdays only. Such a system does not easily account for such eventualities as the employee taking a sick day, or working a Saturday in place of a Friday, or employees with flexible schedules.

FIG. 3 shows an exemplary system diagram for tracking an asset, according to some embodiments of the present invention. The illustrated system may be applied to a more general set of tracked assets, beyond employees. An asset 301 is monitored by a tracking module 302. The tracking module provides the asset locations to a reporting module 303. The reporting module 303 reports the locations of the asset, based on conditions set by a user.

3

The reporting module 303 provides location of the asset or resource 301 to the monitor module 304, under control of a configuration (module) 305. The configuration includes information such as asset name, mobile device identification, boundary areas for alerts, etc. The times for asset to be tracked are supplemented or replaced by the combination of the status monitor module 306 and enablement module 307. The status monitor module, described in more detail below, determines the state of the asset at any given time. Based on the state, the enablement module 307 determines whether tracking is permitted and indicates to the reporting module whether location information may be delivered. Obtaining the location of the asset may depend on the configuration. Reporting the location of the asset may also depend on the enablement module, as well as the configuration.

In some embodiments, the status monitor module keeps track of the asset's status, for example, as a binary state: either "at work"/"on the clock" (allowing the asset to be tracked) or "off work"/"off the clock" (preventing the asset from being tracked). This may be implemented any number of ways. In some embodiments, the invention uses a device based on a traditional time clock, where employees (physically) clock in and clock out when arriving at, and leaving work. For people or assets that do not report to a central location each day, other methods, such as sending a text message or email, making a phone call, or logging in to a web portal may be available.

In some embodiments, the status monitor module has more complex permission states. A third state could indicate a person's or an asset's eligibility for tracking only with a positive response to an explicit request for permission to be located. So, in this case while a user has given permission to be located during a particular period of time, their consent may be granted by the user on a case-by-case basis based on the requestor of the location or their current status during the authorized timeframe, but automatically denied if outside the authorized timeframe.

In some embodiments, other sets of states allow the person or the asset to be tracked with varying degrees of accuracy depending on the location of the asset or the time of the location request. For example the person or the asset may be tracked by exact location while on the clock, tracked by neighborhood on lunch hour, and not tracked at all on the weekend. Also, the varying degrees of tracking accuracy might be determined by privacy concerns or cost, where less exact locations may be less expensive. A long haul delivery vehicle might need only the less expense/less accurate tracking while on the open road, but require more precise tracking near the terminus points.

The following examples show how a variety of trigger events can be used to set tracking status. A tracking status may be assigned to a person or vehicle entering a sensitive area such as a military base; a person or vehicle leaving a known area, such as a school or worksite; an emergency vehicle with its lights/siren engaged; a vehicle traveling at an excessive speed; and/or a container loaded onto a ship, which would not need to be tracked individually until later when it is unloaded from the ship.

The enablement module 307, which in some embodiments may not be distinct from the status monitor module, indicates the person or asset tracking permission to the reporting module. When not enabled, the reporting module 303 prevents location information from being delivered to the status monitor module, thus protecting the asset's privacy during non-work hours. However, depending on permissions, the reporting module could be configured to provide a person's location to other requestors, as in a family location scenario, regardless of the person's "at work" status.

4

FIG. 4 shows an exemplary logical flow of a reporting module, according to some embodiments of the present invention. As shown, the reporting module waits for a tracking request to be received 401, for example, from a status monitor module. When a request is received, the configuration is optionally checked 402, for example, to verify the status monitor module's credentials, verify the identity of the tracked person or asset, etc. If the configuration verification fails, no location is returned 407. If the configuration verification is successful, a status enablement check is performed 403. In this process, the enablement state determined by the status monitor module and enablement module is checked to see if tracking is currently allowed, and any associated constraints (e.g., low precision tracking only). If tracking is not allowed, no location is returned 407.

If tracking is allowed, then an attempt is made to locate the asset 405 via the tracking module. If the location is not available 405, no location is returned. If the location is available 405, the location is returned 406. The allowance of the tracking may be stored for a next tracking request of the person or the asset.

In some embodiments, a first indication of a current state of the person is received, the current state being one of a plurality of predefined states (e.g., "at work," "off work"). The first indication is triggered by a first action of the person, such as clocking in to work as described earlier. The information about the current state ("at work" in this example) is then stored. Subsequently, a first permission is determined based on the information about the current state, the first permission indicating a first level of allowed location reporting (e.g., "full tracking allowed"). The location of the person is then reported based on the first permission. Later, a second indication of an updated current state of the person may be received, as when the person clock out of work. The updated current state ("off work") is also one of the predefined states, and is also triggered by a second action of the person. The information about the updated current state is then stored, and a second permission is determined based on the information about the updated current state, the second permission indicating a second level of allowed location reporting (e.g., "no tracking allowed"). The location of the person is reported again, or in this example, denied, this time, based on the second permission.

It will be recognized by those skilled in the art that various modifications may be made to the illustrated and other embodiments of the invention described above, without departing from the broad inventive scope thereof. It will be understood therefore that the invention is not limited to the particular embodiments or arrangements disclosed, but is rather intended to cover any changes, adaptations or modifications which are within the scope of the invention, as defined by the appended claims.

What is claimed is:

1. A method for reporting a location of a person, the method comprising:

- electronically receiving, by a processor, a location tracking-request to obtain a current location of the person;
- providing configuration information for the person;
- electronically and dynamically determining a status of the person, responsive to the received request, and based on an action by the person and the configuration information for the person;
- electronically providing permission for access to the current location of the person, based on the determined status of the person;

5

tracking the person with varying tracking precision depending on the determined status of the person, which is based on an action by the person and the configuration information for the person;  
 electronically obtaining the current location of the person, responsive to said permission; and  
 electronically generating a report for the obtained current location of the person, wherein a precision of said report for the obtained current location of the person is based on the determined status of the person, which is based on an action by the person and the configuration information for the person.

2. The method of claim 1, further comprising storing said permission for access to the current location for a next tracking request of the location of said person.

3. The method of claim 1, further comprising electronically verifying the configuration information for the person and obtaining the location of the person based on the verified configuration information.

4. The method of claim 1, wherein the person is an employee, the location of the employee is reported to an employer based on the determined status, and the status of the employee is indicative of whether the employee is at work.

5. The method of claim 4, wherein the status of the employee is determined by one or more of an electronic message, a phone call by the employee, a manual check-in by the employee, and a web-based check-in by the employee.

6. The method of claim 3, wherein the configuration information includes one or more of an person name, a mobile device identification, and boundary areas for reporting.

7. The method of claim 1, wherein the status of the person includes varying degrees of location accuracy to be reported based on the location of the person.

8. The method of claim 1, wherein the status of the person includes varying degrees of location accuracy to be reported based on the time of the location tracking request.

9. The method of claim 8, wherein the varying degrees of location accuracy are determined based on privacy or cost factors.

10. The method of claim 1, wherein the status is assigned to one or more of the group consisting of the person or a vehicle entering a sensitive area, the person or a vehicle leaving a known area, an emergency vehicle with its lights/siren engaged, a vehicle traveling at an excessive speed, and a container loaded onto a ship.

11. A system for reporting a location of a person comprising:  
 a reporting module including a first processor, which includes computer executable instructions for receiving a location tracking request to obtain a current location of the person;  
 a configuration module including a second processor, which includes computer executable instructions for providing configuration information for the person;  
 a status module including a third processor, which includes computer executable instructions for dynamically determining a status of the person, responsive to the received request, an action by the person and the configuration information;  
 an enablement module including a fourth processor, which includes computer executable instructions for providing permission for acquisition of the current location of the person, based on the determined status of the person; and  
 a tracking module including a fifth processor, which includes computer executable instructions for tracking location of the person with varying tracking precision depending on the determined status of the person, and

6

obtaining the current location of the person with a precision determined by the status of the person, responsive to said permission, wherein the reporting module reports the obtained location of the person.

12. The system of claim 11, wherein the tracking module obtains the current location of the person after the determined status indicates that the tracking module is allowed to obtain said location.

13. The system of claim 11, wherein the configuration module is configured to verify the configuration information for the person, and wherein the tracking module obtains the current location of the person based on the verified configuration information.

14. The system of claim 11, wherein the person is an employee, the location of the employee is reported to an employer based on the determined status and the status of the employee is indicative of whether the employee is at work.

15. The system of claim 14, wherein the status module determines the status of the employee via one or more of an electronic message, a phone call by the employee, a manual check-in by the employee, and a web-based check-in by the employee.

16. The system of claim 11, wherein the status of the person includes varying degrees of location accuracy to be reported by the reporting module, based on at least the time of the location tracking request, privacy or cost factors.

17. The system of claim 11, wherein the status is assigned to one or more of the group consisting of the person or a vehicle entering a sensitive area, the person or a vehicle leaving a known area, an emergency vehicle with its lights/siren engaged, a vehicle traveling at an excessive speed, and a container loaded onto a ship.

18. A method for reporting a location of a person, the method comprising:  
 electronically receiving a first indication of a current state of the person, the current state of the person being one of a plurality of predefined states in a configuration information data record for the person, wherein the first indication is triggered by a first action of the person;  
 electronically determining information about the current state of the person based on the first indication triggered by said first action of the person and said configuration information;  
 electronically storing said information about the current state; and  
 electronically determining a first permission for reporting the location of the person, based on the information about the current state, the first permission indicating a precision level of tracking the person and allowed location reporting, wherein said level of tracking the person is based on an action by the person and the configuration information data record for the person.

19. The method of claim 18, further comprising electronically receiving a second indication of an updated current state of the person, the updated current state being one of the plurality of predefined states, wherein the second indication is triggered by a second action of the person;  
 electronically storing information about the updated current state; and  
 electronically determining a second permission for reporting the location of the person, based on the information about the updated current state, the second permission indicating a second level of allowed location reporting.

20. The method of claim 1, wherein the configuration information for the person includes person's name, mobile device identification, times for the person to be tracked, and boundary areas for alerts.

21. The method of claim 1, wherein the configuration information for the person includes entering or leaving a location. 5

22. The method of claim 1, wherein the configuration information for the person includes person at work/on the clock for allowing the person to be tracked, and the person off work/off the clock for preventing the person from being tracked. 10

23. The method of claim 1, wherein the varying tracking precision depends on one or more of the location of the person, the time of the tracking location request, privacy concerns, and cost of the tracking.

\* \* \* \* \*

15

7

Hersh

U.S. Patent Application  
Publication No. 2009/0030770



US 20090030770A1

(19) **United States**

(12) **Patent Application Publication**  
**Hersh et al.**

(10) **Pub. No.: US 2009/0030770 A1**

(43) **Pub. Date: Jan. 29, 2009**

(54) **DYNAMIC AND PREDICTIVE INFORMATION SYSTEM AND METHOD FOR SHIPPING ASSETS AND TRANSPORT**

(75) **Inventors:** Richard Hersh, Sunrise, FL (US);  
Michael J. Darden, Parkland, FL (US); John M. Urbanowicz, Winnetka, IL (US)

**Correspondence Address:**  
**MALLOY & MALLOY**  
**2800 S.W. THIRD AVENUE, HISTORIC CORAL WAY**  
**MIAMI, FL 33129**

(73) **Assignee:** Rentar Environmental Solutions, Inc., Wellington, FL (US)

(21) **Appl. No.:** 12/157,453

(22) **Filed:** Jun. 10, 2008

**Related U.S. Application Data**

(62) Division of application No. 11/151,963, filed on Jun. 14, 2005, now Pat. No. 7,385,529.

(60) Provisional application No. 60/579,594, filed on Jun. 14, 2004.

**Publication Classification**

(51) **Int. Cl.**  
*G06Q 10/00* (2006.01)  
*G08G 1/123* (2006.01)  
*G01C 21/00* (2006.01)  
*G06Q 50/00* (2006.01)  
(52) **U.S. Cl.** ..... 705/9; 340/988; 701/213

(57) **ABSTRACT**

The dynamic, predictive information system and method assigns shipping assets (drivers-tractors-trailers) from carriers to transport orders by shippers. Computer databases hold shipping asset data. Specific transport orders are electronically joined to specific driver-tractor-trailer combinations. A search and sort routine produces resulting records based upon proximity, trailer type, proximity of the joined driver-trailer combination, carrier service region and pick-up and delivery date constraints. The sort is by price or performance indicators which are pre-selected shipper ranges matched to historical shipping data from carriers. The system books the carrier, the driver-tractor-trailer combination and the shipper to transport order with an electronic communications phase. In a truck lane scenario, the system joins a specific driver and a specific tractor and a non-specific trailer to a specific transport order. GPS data and electronic shipping document data from PDAs with the drivers is logged into the system and is viewable by the participants.

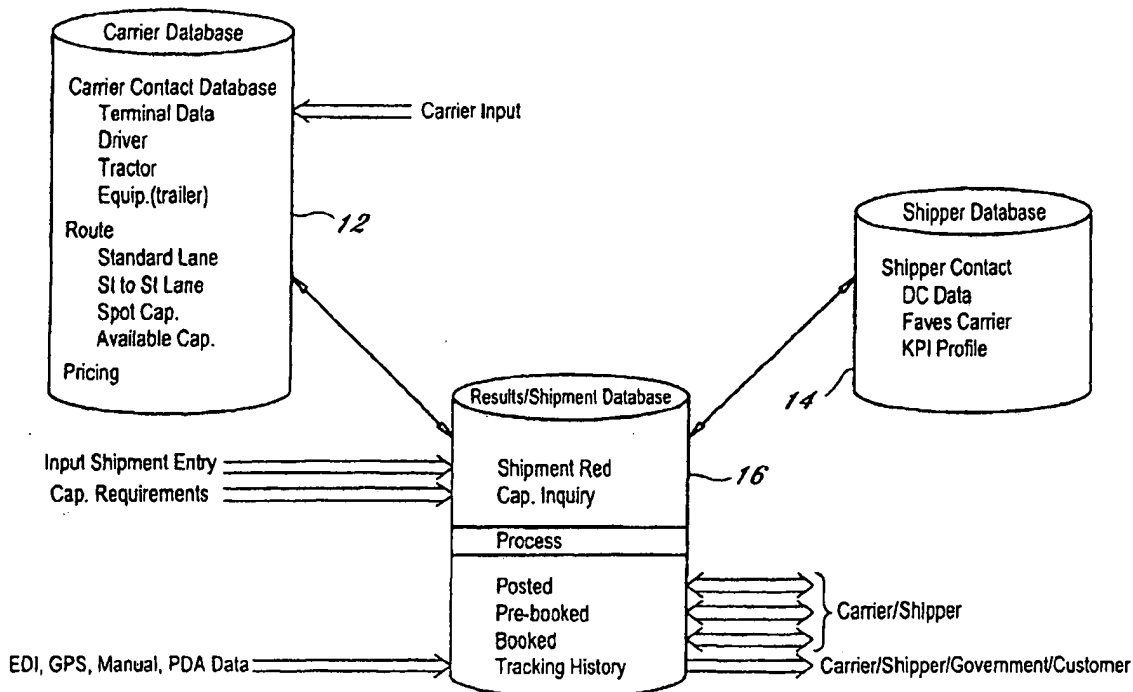



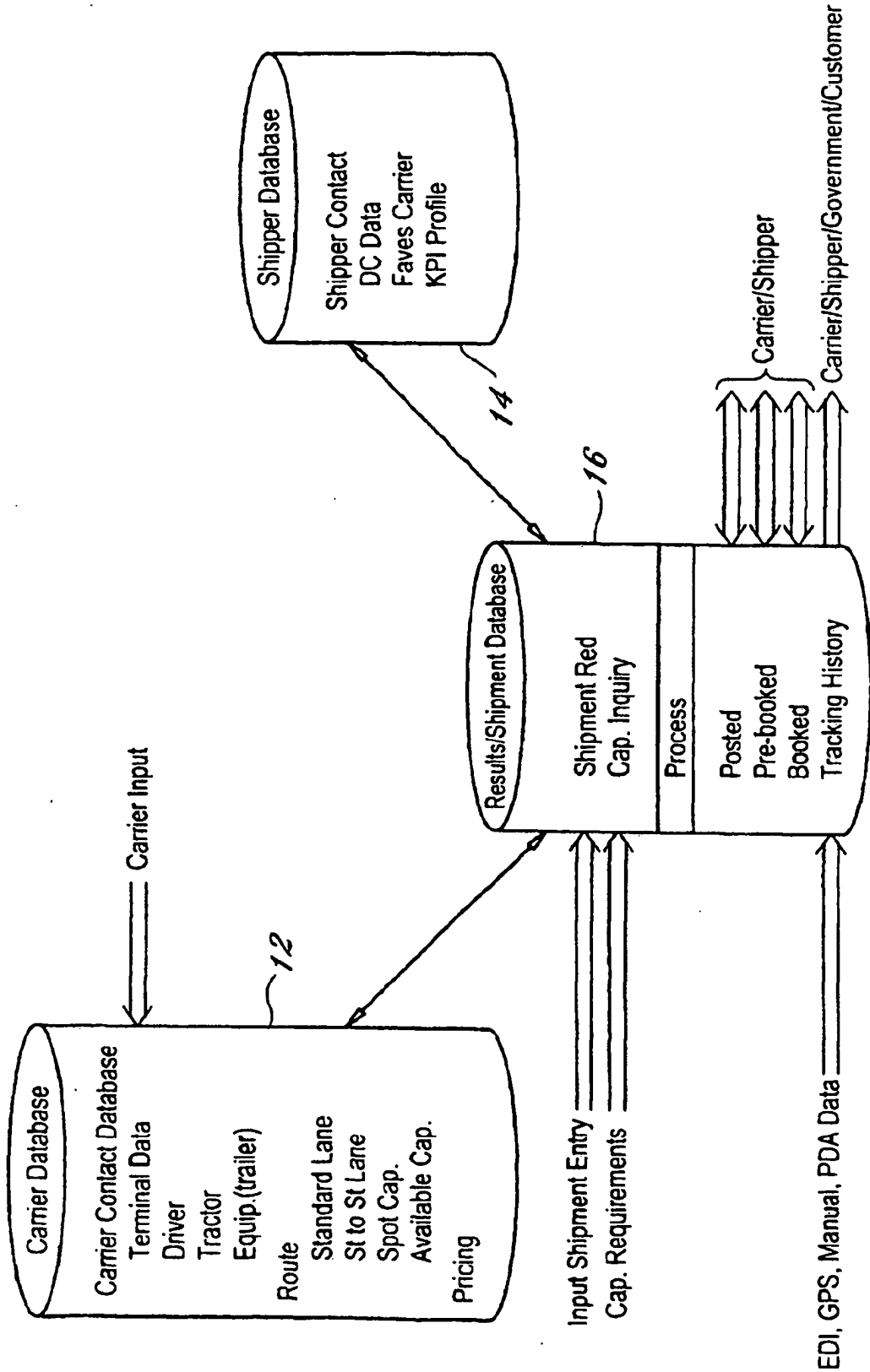

FIG. 1

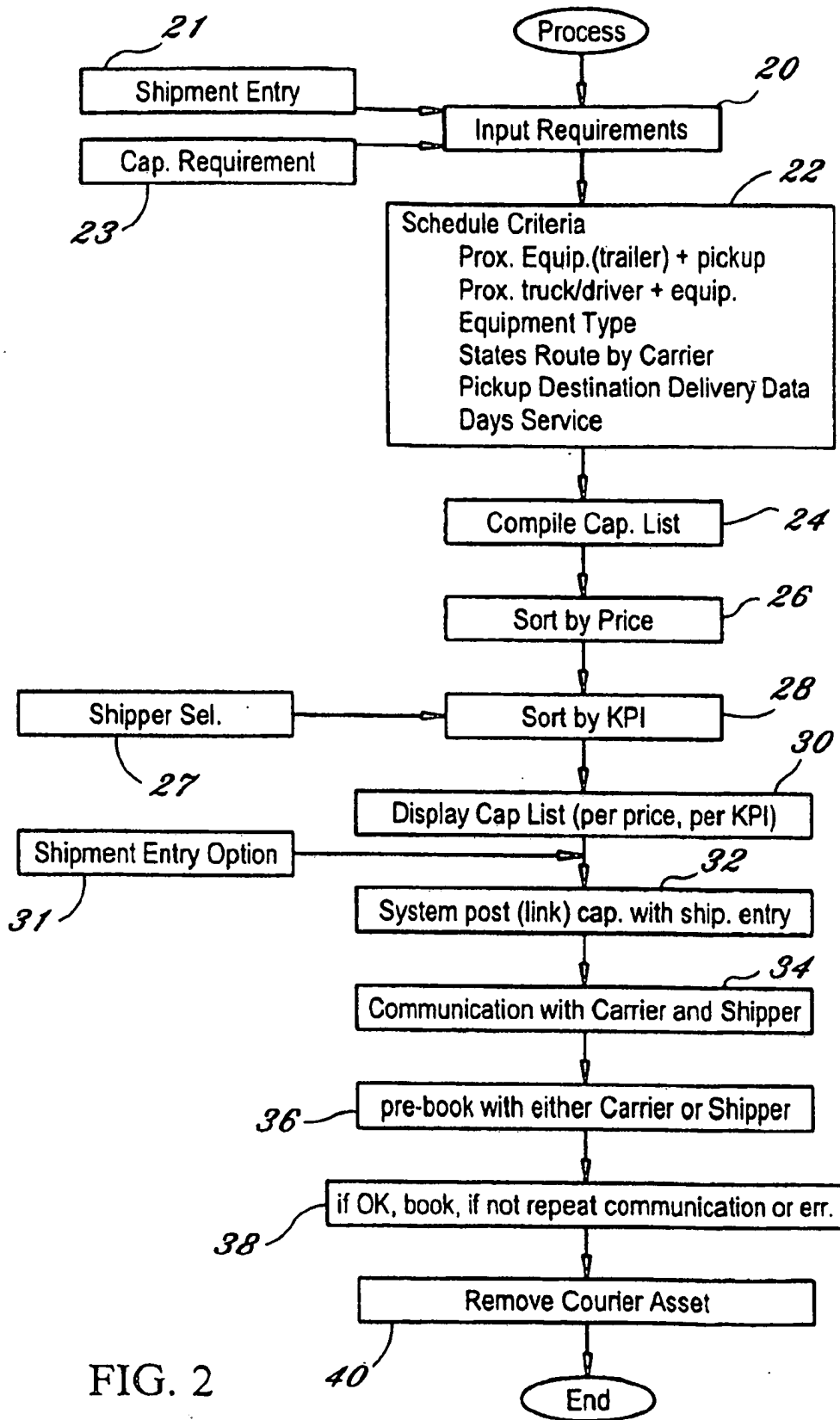

FIG. 2

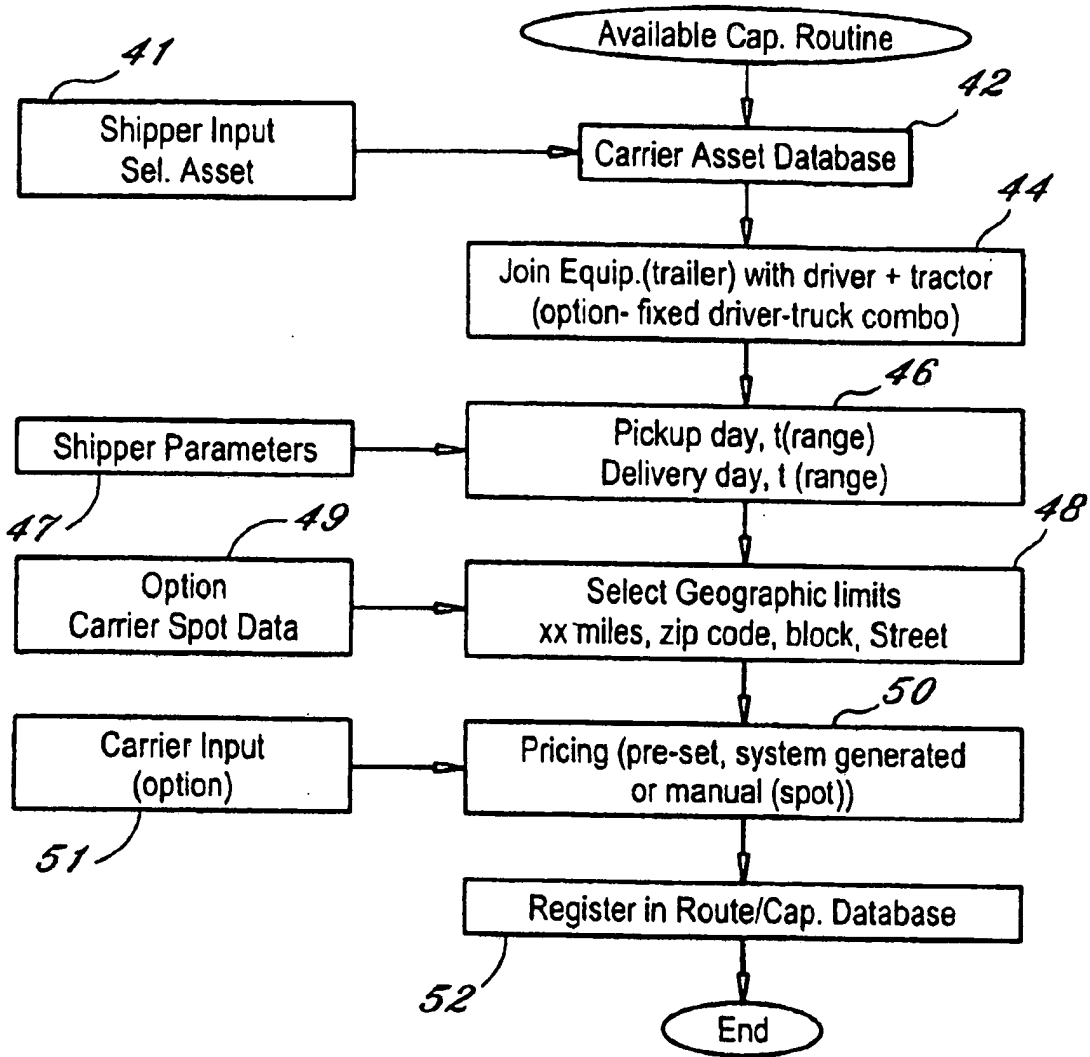

FIG. 3

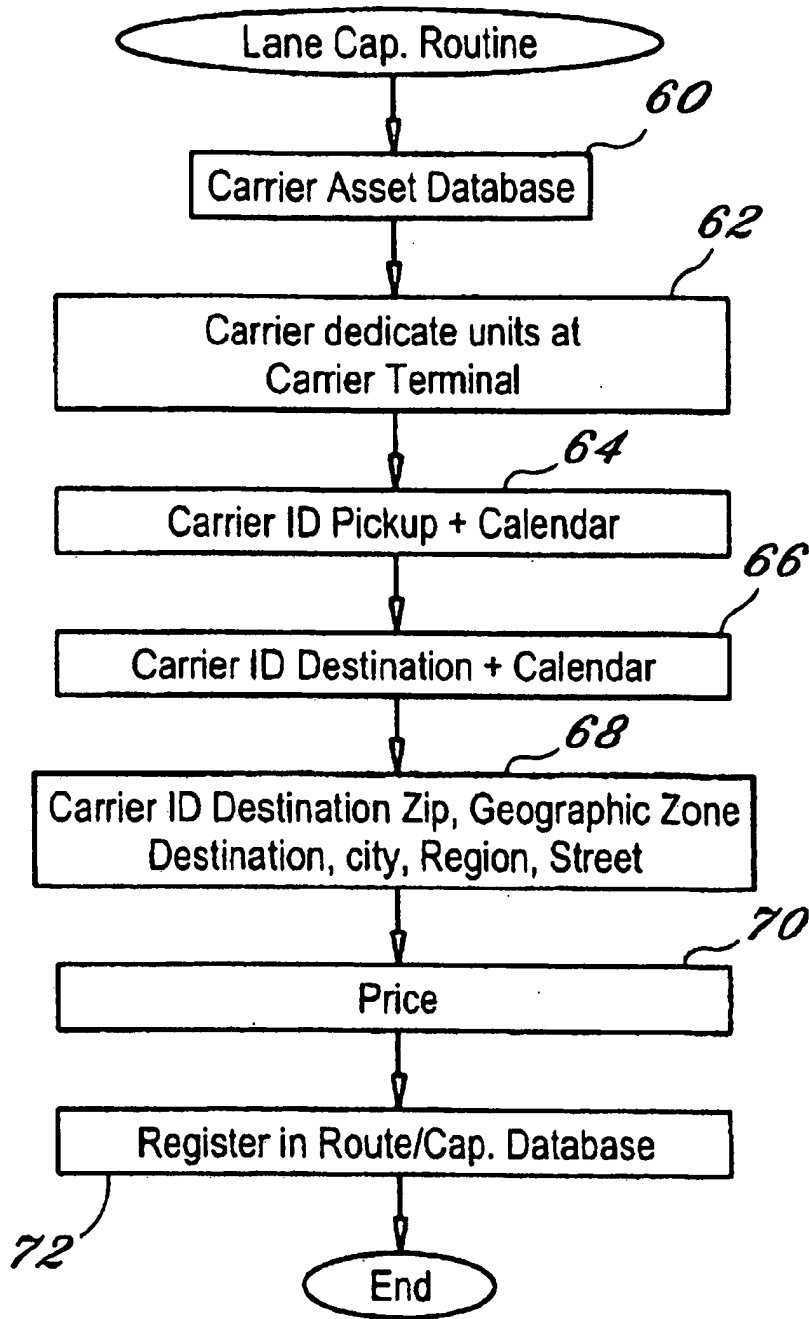

FIG. 4

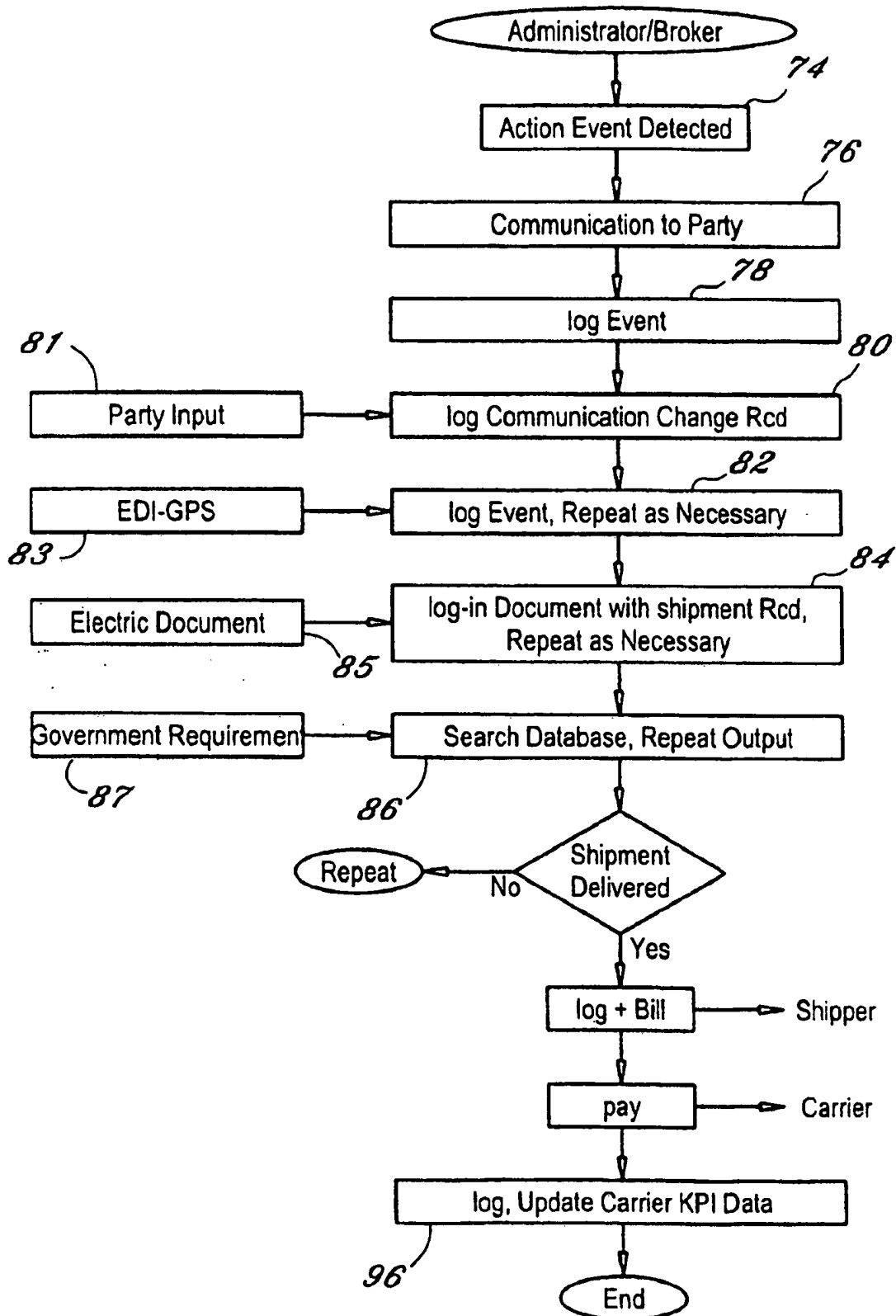

FIG. 5

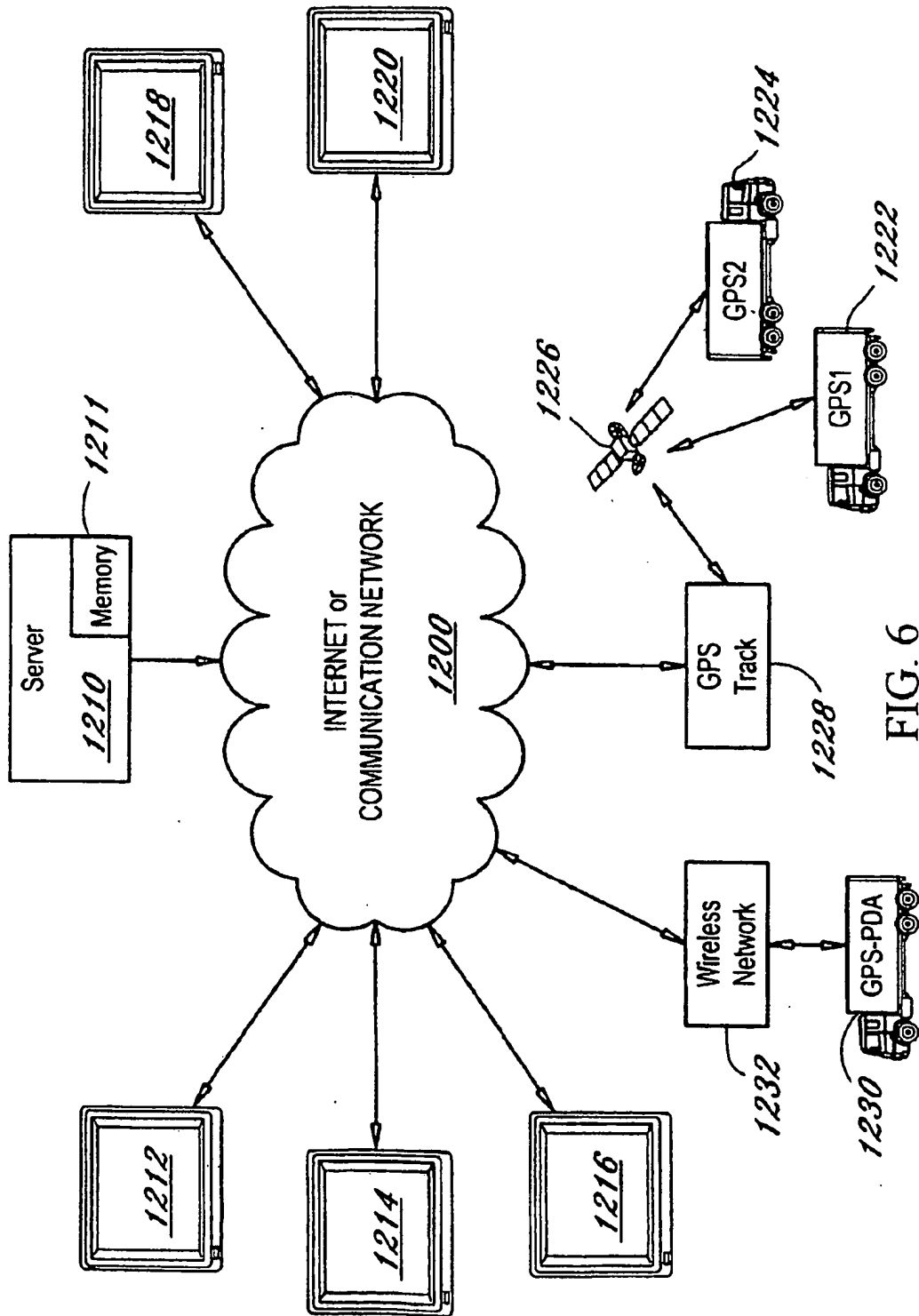

FIG. 6

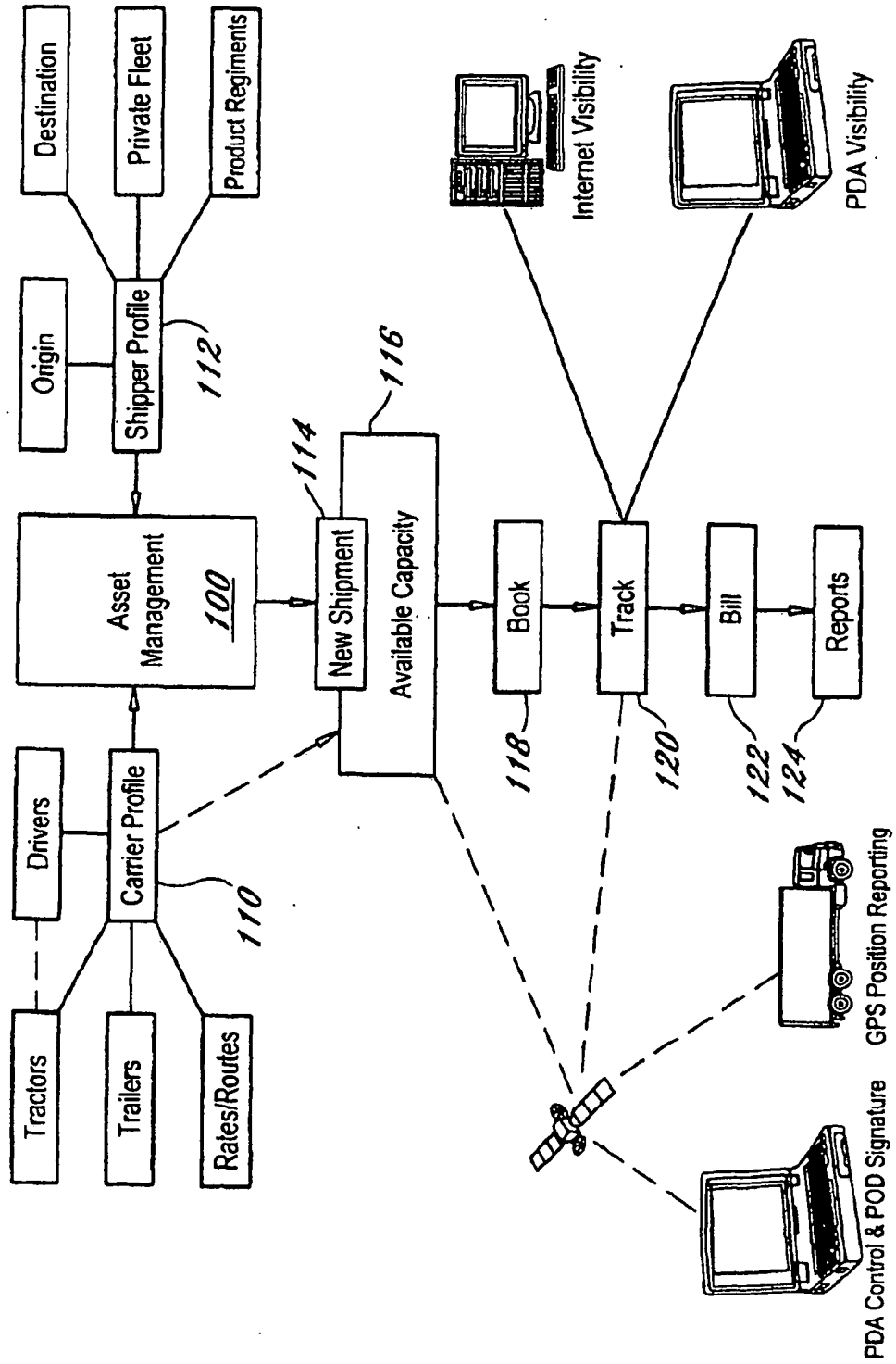
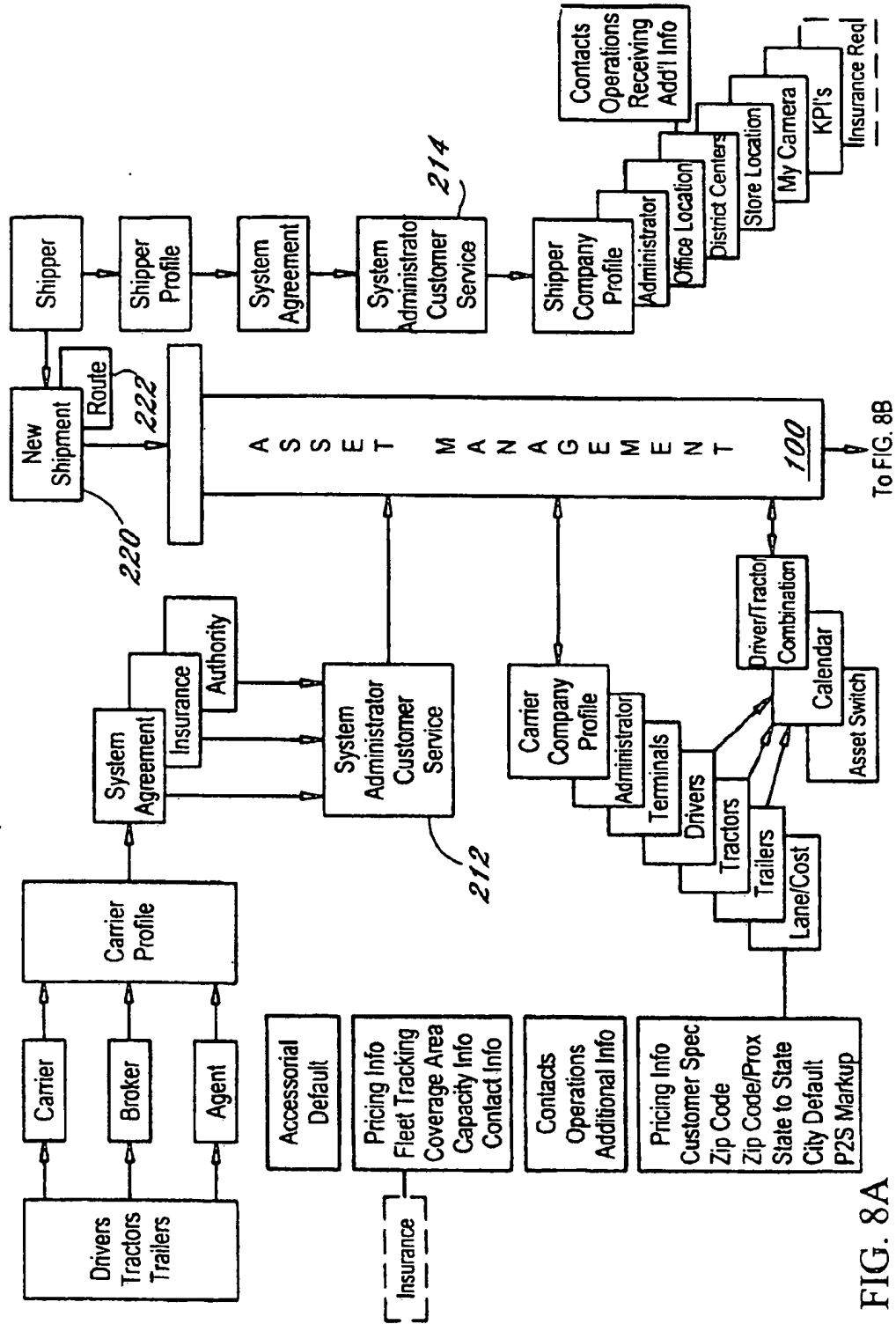

FIG. 7



To FIG. 8B

FIG. 8A



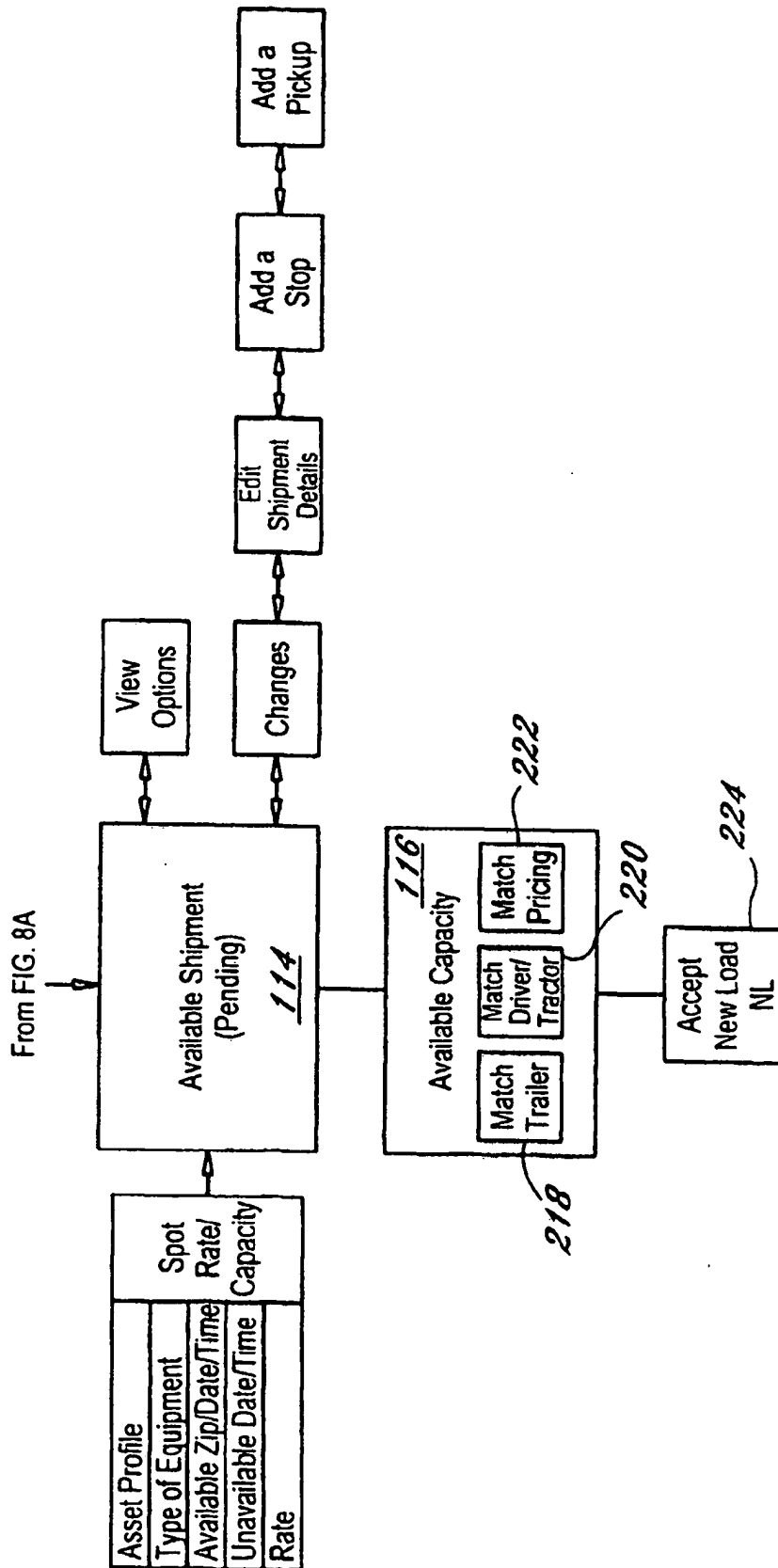

FIG. 8B

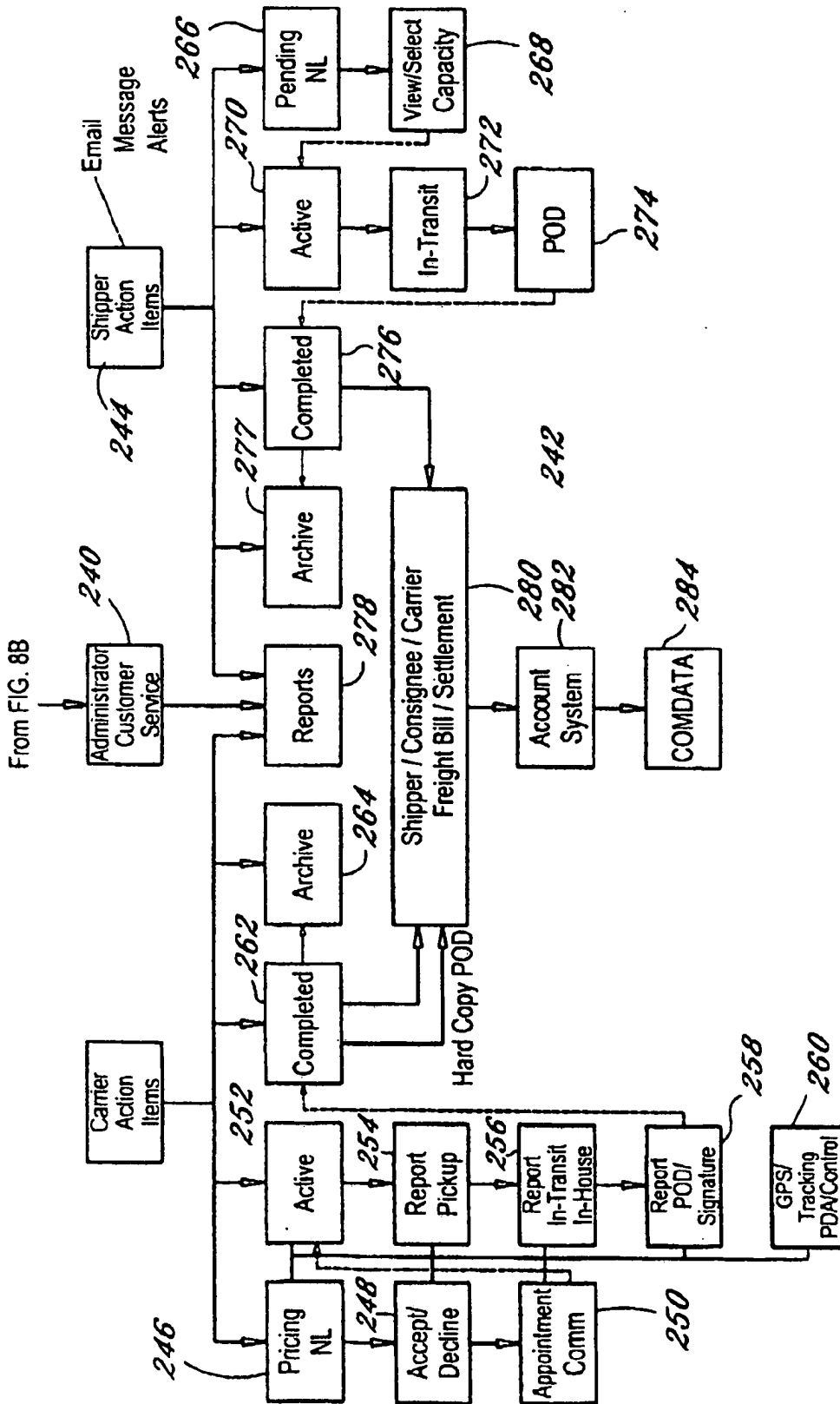

FIG. 8C

**DYNAMIC AND PREDICTIVE  
INFORMATION SYSTEM AND METHOD FOR  
SHIPPING ASSETS AND TRANSPORT**

**CLAIM OF PRIORITY**

[0001] The present application is a divisional patent application of previously filed, application having Ser. No. 11/151,963 which was filed on Jun. 14, 2005, which claims priority to a provisional patent application having Ser. No. 60/579,594 and a filing date of Jun. 14, 2004, and which is incorporated herein by reference.

**BACKGROUND OF THE INVENTION**

[0002] 1. Field of the Invention

[0003] The present invention relates to a dynamic and predictive information system and method for assigning shipping assets to goods subject to transport orders.

[0004] In the transportation industry, vehicles transporting goods typically are identified as shipping assets. Shipping assets include truck drivers, tractors, trailers, containers, ships, railcars and airplanes. These shipping assets can sometimes be rearranged such that drivers operate different tractors and the driver-tractor combinations are sometimes coupled to different trailers at different times for different routes. In other instances, drivers are permanently assigned tractors. In some of these situations, the drivers may have a financial interest in the tractor which they use to haul loads. Further, in some instances, the drivers, tractors and trailers are permanently combined, linked, joined or associated with each other and are viewed as a singular shipping asset when special transport needs (for example, radioactive goods or large sized goods such as cranes) must be shipped from point to point. Special tractors must be coupled to special trailers to haul special goods. Sometimes, the drivers must have special skills. One type of permanently joined driver-tractor-trailer combination is called a "straight truck."

[0005] In any economic environment, it is necessary to efficiently transport and deliver goods from distribution centers, ports, warehouses and other locations to retail stores, other warehouses and further ports and airports. The timing and scheduling of shipping assets and the scheduling of those assets to match transport needs of customers is a challenge. About 94% of independent carriers (companies employing shipping assets) have less than 30 trucks. Approximately 20-25% of these assets, that is, a driver-tractor-trailer combination, travel over routes without a full load or are completely empty. The transit of empty trucks is not an efficient use of shipping assets. Further, the matching of a customer's need to ship goods from point to point within a designated time frame (both the pick-up day, time and location and the delivery day, time and location) with available shipping assets at the most reasonable price and/or performance (historical on-time delivery percentage and/or an absence of delivery/shipment problems) is a challenge. There is a need to provide and manage logistics for the transport of goods and the efficient use of shipping asset

[0006] 2. Description of the Related Art

[0007] It is an object of the present invention to provide a dynamic, predictive information system and a method for assigning shipping assets to goods subject to transport orders.

[0008] It is a further object of the present invention to preemptively process and assign shipping assets, that is, driv-

ers, tractors and trailers, available from a plurality of carriers to carry a load of goods subject to transport orders from a plurality of shippers.

[0009] It is a further object of the present invention to provide a method and a system which is transparent to the carrier and the shipper and the system administrator such that the carrier and shipper can identify the location of the goods subject to transport and view, on an electronic basis, electronic shipping documents showing classic events in the handling of the goods subject to the transport order.

[0010] It is another object of the present invention to provide a method for electronically assigning shipping assets and an information system therefor which is independent of any hardware operating the computer program or employing the electronic method.

[0011] It is an additional object of the present invention to provide just-in-time asset assignment of shipping assets to transport orders.

**SUMMARY OF THE INVENTION**

[0012] The dynamic and predictive information system and method assigns shipping assets (drivers, tractors and trailers) from a plurality of carriers to enable the shipment of goods subject to a plurality of transport orders from a plurality of shippers. A central computer maintains the database with data representing shipping assets wherein each carrier has at least one terminal from which respective shipping assets originate, respective service areas or regions, pricing schedules and, in some instances, lane routes (specially designated routes) which are often traveled by truck combinations of a particular carrier. The system and method electronically accepts a specific transport order and electronically joins a specific driver, a specific tractor, a compatible trailer for the goods subject to transport. A plurality of carriers participate in the assignment of assets. The system electronically searches the database and sorts the resulting records based upon close proximity of the trailer type to the ship from origin location, close proximity of the joined driver-tractor combination to the ship from origin, carrier service region encompassing the ship to destination, and pick-up and delivery date constraints. The sorted list, showing prices, is displayed to the shipper submitting the specific transport order. This display results in a posting of the assets to a specific transport order. In conjunction with an electronic communication between a selected carrier, typically selected by the shipper submitting the specific transport order, and the shipper with the transport order, the system books and electronically logs the carrier, the associated driver-tractor-trailer combination to transport order. During the electronic communication phase, the carrier, driver-tractor-trailer combination and transport order for the goods is considered to be pre-booked. When a specific carrier and shipper agree on all terms and conditions, the transaction is booked. The term "booked" results in a legally enforceable contract. Booked means that the shipping assets are no longer available to be assigned by the system during the pick-up and delivery times and days. In a truck lane scenario, the system joins a specific driver and a specific tractor and a non-specific trailer to a specific transport order. As explained later, in a lane assignment, the carrier is assumed to have a capable and an available trailer at his or her terminal (the location of various shipping assets). With the use of global positioning system (GPS) units and personal data assistant (PDAs) carried and removably mounted in the tractors and used by drivers, the electronic information system can monitor the location of the

trailer, the driver and also handle electronic copies of the electronic shipping documents (bills of lading, warehousing documents, customs documents, etc.). Since the PDA can capture data relative to the electronic shipping documents (signatures, delivery or exception notes, etc.), the driver and others coming in contact with the goods on the trailer, can annotate the electronic shipping documents on the PDA. This annotation is electronically noted and uploaded from the PDA along with GPS data to the central computer operating the information system. This GPS data and electronic document data is associated with the transport order such that the carrier and the shipper and the customer having an interest in the goods under transport can see and view the electronic document and whereabouts of the goods or load. Government agencies or others interested in tracking goods subject to transit may also have access to this data including electronic documents subject to the transport order. Of course, security codes and passwords are used to limit access to the system data to protect commercial interests of the carriers and the shippers and the customers.

[0013] These and other objects, features and advantages of the present invention will become more clear when the drawings as well as the detailed description are taken into consideration.

#### BRIEF DESCRIPTION OF THE DRAWINGS

[0014] For a fuller understanding of the nature of the present invention, reference should be had to the following detailed description taken in connection with the accompanying drawings in which:

[0015] FIG. 1 diagrammatically illustrates an information system showing a carrier database, a shipper database and a results or shipment database and various inputs and outputs and processes utilizing in the data therein;

[0016] FIG. 2 diagrammatically illustrates one embodiment of a process routine or program subject to the dynamic and predictive information system and method herein;

[0017] FIG. 3 diagrammatically illustrates the available capacity routine;

[0018] FIG. 4 diagrammatically illustrates the lane capacity routine;

[0019] FIG. 5 diagrammatically illustrates an example of an administration and broker routine;

[0020] FIG. 6 diagrammatically illustrates an example of a distributed computer system or one implementation of a system for the information processing method herein;

[0021] FIG. 7 diagrammatically illustrates a system diagram and a major flowchart therefor; and,

[0022] FIGS. 8A, 8B and 8C diagrammatically illustrate a data flow chart for one embodiment of the system and method.

[0023] Like reference numerals refer to like parts throughout the several views of the drawings.

#### DETAILED DESCRIPTION OF THE PREFERRED EMBODIMENT

[0024] The present invention relates to a shipping information and capacity allocation system, a methodology for the same, typically operable over the Internet (with interconnected personal computer (PC) system, mini-computers and main frames (in certain situations)), or over a computer network (LAN or WAN), and various computer programs, computer modules and an information processing systems to

accomplish asset allocation and shipment tracking system. In addition to the computer implementation of the inventive aspects of this invention, a business method is also encompassed herein.

[0025] It is important to know that the embodiments illustrated herein and described herein below are only examples of the many advantageous uses of the innovative teachings set forth herein. In general, statements made in the specification of the present application do not necessarily, limit any of the various claimed inventions. Moreover, some statements may apply to some inventive features but not to others. In general, unless otherwise indicated, singular elements may be in the plural and vice versa with no loss of generality. In the drawings, like numerals refer to like parts or features throughout the several views.

[0026] The present invention could be produced in hardware or software, or in a combination of hardware and software, and these implementations would be known to one of ordinary skill in the art. The system, or method, according to the inventive principles as disclosed in connection with the preferred embodiment, may be produced in a single computer system having separate elements or means for performing the individual functions or steps described or claimed or one or more elements or means combining the performance of any of the functions or steps disclosed or claimed, or may be arranged in a distributed computer system, interconnected by any suitable means as would be known by one of ordinary skill in the art.

[0027] According to the inventive principles as disclosed in connection with the preferred embodiments, the invention and the inventive principles are not limited to any particular kind of computer system but may be used with any general purpose computer, as would be known to one of ordinary skill in the art, arranged to perform the functions described and the method steps described. The operations of such a computer, as described above, may be according to a computer program contained on a medium for use in the operation or control of the computer as would be known to one of ordinary skill in the art. The computer medium which may be used to hold or contain the computer program product, may be a fixture of the computer such as an embedded memory or may be on a transportable medium such as a disk, as would be known to one of ordinary skill in the art. Further, the program, or components or modules thereof, may be downloaded from the Internet or otherwise through a computer network.

[0028] The invention is not limited to any particular computer program or logic or language, or instruction but may be practiced with any such suitable program, logic or language, or instructions as would be known to one of ordinary skill in the art. Without limiting the principles of the disclosed invention any such computing system can include, inter alia, at least a computer readable medium allowing a computer to read data, instructions, messages or message packets, and other computer readable information from the computer readable medium. The computer readable medium may include non-volatile memory, such as ROM, flash memory, floppy disk, disk drive memory, CD-ROM, and other permanent storage. Additionally, a computer readable medium may include, for example, volatile storage such as RAM, buffers, cache memory, and network circuits.

[0029] Furthermore, the computer readable medium may include computer readable information in a transitory state medium such as a network link and/or a network interface,

including a wired network or a wireless network, that allow a computer to read such computer readable information.

[0030] The term "database" means all types of data structures whether in flat form, such as a spread sheet, or other forms (such as a matrix of data) or any organized data structure, such that groups of data, associated with a single item, such as a truck or carrier asset, are organized into fields or sub-groups such that the group or record for a single asset can be easily compared or sorted or processed by association to similar sub groups for other asset records. Although one or more databases are identified herein, persons of ordinary skill in the art will recognize that a singular database or spreadsheet may be used or multiple databases may be employed rather than the few discussed in detail herein. Hence, the designation of a Carrier Price database, and a Shipping Asset database and a Results database is a conceptual tool employed herein to explain the dynamic operation of the system as a whole and such designations are not meant to limit the scope of the claimed invention. A single database with multiple indices may be more efficient than the separate databases discussed herein.

[0031] In the drawings, and sometimes in the specification, reference is made to certain abbreviations. The following Abbreviations Table provides a correspondence between the abbreviations and the item or feature.

Abbreviations Table	
Admin	administration
Alert	electronic message to system operator, carrier or shipper
ASP	application service provider - server on a network
bd	board
cap.	available capacity (avail. cap.), dynamic capacity (dyn. cap.), spot capacity (spot cap.)
Car	carrier (trucking company, freight forwarder, drayage, railroad, airline etc.)
comm.	communications, typically telecommunications
comp	computer
CPU	central processing unit
cust'r	customer who owns or has rights to the goods being shipped
DB	data base
DC	distribution center, usually, the primary location of goods to be shipped
del	delivery location or destination
destin.	destination, such as the final delivery point for goods being shipped or a destination of a leg of a multi-modal transportation transaction
displ	display
doc	document (may be electronic or printed out)
edi	electronic data input (typically a standard format electronic input/output format and data stream and comm. protocol)
elec. doc.	electronic document, typically a signed PDF doc
equip	equipment, typically a trailer or means to carry the goods
err	error, typically resulting in an Alert to a party
except	exception noted as a problem with goods being shipped
favorites	favorites
Geo Fence	a GPS signal indicating that an item is within or is without a defined geographic region from a known location
gov't	government or agency inquiry
GPS	global positioning system equipment, transceiver, or signal
I/O	input/output
id	identify
KPI	key performance indicators
LTL	less than full truck load of goods
mem	memory
ntwk	network as in "comm ntwk" - communications network

-continued

Abbreviations Table	
pgm	program
PO	purchase order
prox.	proximity, such as xx miles near a zip code or location
p/u	pick-up location where the goods are to be picked up
req	request
rpt	report
sch	search
schdle	schedule
sel	select, normally, an input selected by a user
Shpr	Shipper, the company wanting to ship goods
std	standard
St.	state, such as in a state to state route lane, e.g., FL to NY
sys	system
t	time
Term.	primary, initial location of assets, such as trailers, tractors, etc., used to ship goods
tele-com	telecommunications system or network
URL	Uniform Resource Locator, x pointer, or other network locator

[0032] The primary goal of the method subject to the present invention and the information processing system is to find the best match for a shipper sending a shipment (represented by a transport order for goods) with a carrier having the shipping assets or capacity to move the shipment, based on individual preferences determined by both parties and using the carriers' identified price per mile as the tiebreaker.

[0033] The key criteria for searching the database, extracting records, sorting the records and then displaying the selection are set forth in the following table.

Search and Selection Table - Key Criteria
Close Proximity of equipment (trailer) to the shipment pick-up location
Close proximity of the Truck/Driver combination to the trailer
Equipment type (Specific or All) (for example, 53 ft refrig., 45 ft dry, 53 ft)
States/Regions Serviced by Carrier Organization
Pick-Up and Delivery Date Constraints
Days of Service Constraints
Sorted by Price or KPI (Shipper selects sort criteria)

[0034] See FIGS. 1 and 2 and the associated description discussed later which more fully explains this and other features of the information system and shipping asset assignment or scheduling method.

[0035] Carriers who use the information system, sometimes called "members," have full use of the asset management functionality of the system including the ability to allocate their assets for the future to make them available for shipper view and selection for a desired shipment of goods. Pricing and performance play an important role in the sorting and display of available capacity information. At the option of the specific shipper interacting with the system after input (manual or automated) of a transport order to shipping load record, capacity is displayed to the shipper by lowest price or best KPI (Key Performance Indicator). KPI is represented based on the history of shipments vs. the number of exceptions (errors in shipment) that have been logged into the system for a specific carrier. The shipper selects one performance level L2-14; one transit time level (an one time deliv-

ery ration) L2-H; and one price level. If a price factor is important, Level H, and performance (lack of exceptions or delivery problems) is not (level L2) and transit time (one time delivery ratios) is less critical (level M), the lowest price carrier is displayed first.

Key Performance Indicator (KPI) Table					
Performance	Low (L2)	L1	Med.	M2	High
Transit Time	L2	L1	M	M2	H
Price	L2	L1	M	M2	H

[0036] Shipper members using the system have the ability to enter shipments (transport orders for goods subject to transport) either manually or through an automated data interface (EDI or web-based input form) to post loads into the system and view available capacity of carrier members. In addition, shippers have the ability to manage their own in-house shipping assets or fleets (tractors, trailers, drivers and equipment) by using the system's shipper asset management/route scheduling tools (known as Shipper "B").

[0037] The following table shows various types of shipments based on full truck load.

Shipment Table
Shipper - Single pickup to single destination shipment.
Shipper - Multi pickup to single destination shipments (line haul or run).
Shipper - Single pickup to multi destination (line haul or run).
Carrier in-house shipment. Used to allocated activity for shipments not entered to the system in order to provide future available capacity information.

[0038] For each shipment record, the status codes listed below are used. The terms "posted" and "pre-booked" and "booked" are explained, in part, in this table. The Shipment Entry Input Table later. The codes form the Status Code Table are associated with each shipment record status of the record.

Status Code Table - Shipment Record		
Status #	Description	Explanation
10	Hold	Shipment (transport order or shipment record) loaded in system with invalid data - error code set
20	Posted	Shipment Entered into system
30	Pre-Booked	Shipment with Carrier Selected (shipping asset temporarily withdrawn from "available capacity")
40	Booked	Shipment after Carrier Accepts
50	En-Route	Shipment Currently Moving
52	En-Route-Arrived	Geo Fence Triggered via GPS device
70	Delivered	Shipment Delivered
71	Delivered-Pending	Shipment Delivered with Dispute or a Dropped Trailer Pending Count
72	Delivered-Exception	Shipment Delivered with Overages, Shortages or Damages (OS&D)
80	Invoiced	Shipment Invoiced by Accounting Sys.
90	Completed	Shipment Completed
95	Delete	Shipment Cancelled by Customer
99	Cancelled	Shipment Cancelled by Sys. Admin.

[0039] The following table shows a less than full truckload shipment record. Less than full or LTL truck load shipment records represent unused capacity which is difficult to sell or match up with an acceptable shipper.

LTL Entry Table
Carrier: WN. TRUCKING
Shipper: King Products
BOL Number (bill of lading no.)
PRO Number (government or agency assigned no.)
Shipper PO Number
Stop Number
Equipment Type
Class/NMFC
Quantity
Load Size
Linear Feet Required
Pick-Up Number/Seal Number
Pricing Information: Carrier Price
Pick-up Information: Delivery Location, address, city, Delivery Date

[0040] Data entry methods may vary and may include manual input, electronic input or automated input such as matching existing inventory control systems to the input categories of the present system. Shipper contact data (name, address, phone, fax, email, etc.) and shipper distribution center (DC) data entry is important. A DC is the location where a particular shipper has a warehouse of goods subject to transport to other locations. New shipment entry may be manual or automated. The table below lists typical fields for a shipment record. Pull down menus are used for certain fields, such as equipment or trailer type. The system generally uses zip codes to sort and determine proximity to certain locations. See FIG. 2 and the associated description discussed later which more fully explains this and other features of the information system and shipping asset assignment or scheduling method.

Shipment Entry Input Table
Initial Pick up Information: Pick Up Location, Address, City/State/Zip
Shipment Will be Ready: Date, Time
Contact Name/Telephone Number
Final Delivery Information: Delivery location, Address, City/State/Zip
Must Be Delivered No Later Than: Date, Time
Contact Name/Telephone Number
Shipment Information: Equipment (trailer) Type; Shipment Type

[0041] The following tables show typical data entries for carriers having shipping assets they wish to exploit. The carriers may place shipping assets on the system for all shippers to use or schedule or the shippers may have "in-house" or fleet trucks used only by the owner-shipper. In-house or fleet trucks are not typically subject to hire by other shippers.

Driver List Table
ID
Driver Name

-continued

Driver List Table
Terminal of Carrier (crr.) where driver typically is assigned from
Active Y/N
PDA Password
Calendar
Add/Edit Driver Table
Terminal Center
Driver's First Name
Driver's Last Name
Dispatch From Address
City
Driver's Email Address
Driver's Mobile Phone Number
HazMat Certified
PDA Unit ID Assigned
Commercial Driver's License
Driver's Days of Work
Independent Contractor
Active (Yes/No)
Add/Edit GPS Devices Table
Company, Company ID, Unit ID
Type Manufacturer, Serial no.
Firmware, Mode
Current Lanes and Cost Table
Lane
Start Zip, Start City, Start State
End Zip, End City, End State
Expires
Equipment Type
Price Dry, Price Reefer (refrigerator), Price Flat
Lane Cost Dry, Lane Cost Reefer, Lane Cost Flat
Miles Willing to Drive Empty at No Charge to Get a Load
Preferred Shipper Name
No. Truck

[0042] Data may be entered manually or electronically. Further, brokers resolving scheduling issues and pricing aspects are typically employed in the shipping industry. The system can be used by brokers to quickly schedule available carrier capacity and match that available capacity to the transport needs of a shipper for a designated load. The system is designed to accept electronic data entries are set forth in the following table.

Custom Data Feed Support Table
EDI X.12 ASN Support
EDI Carrier Shipment Status Information and Updates (990, 210, 214)
Custom Flat File Purchase Order
Email Attachment Shipment information (Custom)

[0043] Shipment tracking is provided for all carriers, shippers, brokers and to the system administrators using the information processing system with input coming from a number of manual and automated interfaces. As each event in the handling of the goods subject to transport occurs, a historical record is logged and maintained in the system.

Historical Movement Table
Informational Changes
All Events

[0044] The following Booked Shipments Table can be accessed (that is, the database can be searched and a singular or multiple records can be retrieved based upon selection of the field category).

Booked Shipments Table
Shipper - Carrier - Run
Reference - Stops
Pick Up Date - Pick Up - Delivery Date
Destination - Carrier Tracking Table
Capacity
PRO (gov't id), PO, BOL
Run (lane), Shipper, Tractor, Trailer
Origin, Destination
Status of Shipment (see Table above), Except.
Posting Date

Shipment Status Table		
Shipper	Carrier	Run
PRO	BOL	Activity
Shipper	Shpr. Acct. Owner	
Carrier	Crr Acct Owner	
Run, BOL, PRO, Stops, Pick Up Date, Pick Up, Delivery Date		
Delivery, Broker		
Details (selection of "details" leads the user into more detailed records of the shipment)		
Shipment Journal (log notes for a user, a driver (with PDA), telephone notes from driver, etc.)		
Status		

GPS Device Log Table
GPS id no.; Crr. id no.
Control or Receive
MSG (message) Codes; Subcode; Message; Unit id
Time, Tracking

Shipment Notes Log Table
Company Notes, User, Date-time Created, Content of notes ("LS shipper Corp. advise me that . . .")

Shipment Event History Table
Run No. (assigned by sys. - sys. tracking no.), Shipper, Shipment Status,
Accepted Date, Pick Up Date, Delivery Date, POD Received, Invoice Received, Invoice Number, Line Haul Charge, Accessorial Charge, Exceptions

[0045] When a shipment encounters a problem, the information processing system supports automated and manual exception entry to effectively build a journal and supplemental journal for the shipment. These entries are noted above in some of the tables.

Action Items Table (Admin)
Shipment ID, Code, Date, Priority Comments: Truck 521 has a Spot Rate for \$1.85 per mile from Pilot

[0046] Shipping assets (real, currently available or dynamic—not specifically identified assets but assets available in the future) within the system need to be tied to a home terminal of a carrier or to a Distribution Center for a shipper. The system handles a hierarchy of organizations including a parent organization to manage the assets and information related to those assets at each terminal (Term) or distribution center (DC). Each child relationship in the organization will not have access to equal children at their respective hierarchy. Simply, a user can see all the children or nodes of the organizational tree that are lower than their respective login home. Thus a parent user will have the ability to view the entire organization from the top down. The system has security password control and log-in historic data entries to maintain this security of information.

[0047] Each Terminal or DC is the controlling home base for all assets. When adding or editing an asset, validation of a home terminal/DC is enforced. All assets are required to have home terminal/DC with each specific asset having their own specific information that is required and validated.

[0048] "Capacity" is segregated into "available capacity" and "dynamic capacity" and "spot capacity." The primary differences between these categories are that spot capacity is unique and is typically not a shipping asset originating from a Carrier Terminal but is a truck on the road in a non-standard location, such as when a non-tracking truck has just off-loaded goods and is now empty. Dynamic capacity is a term used for explanatory purposes only and represents a non-specific or a non-identified trailer or other asset that (a) is available but (b) is not identified with certainty as is all other assets. Drivers, tractors, trailers and other equipment in the system are identified with certainty such that the system can issue scheduling reports, email communications, etc. to carry out a booked transport order. A dynamic assignment means that the carrier must provide the shipping asset at the terminal. Typically, dynamic capability is used with lane assignments or lane routes.

[0049] Available capacity is defined as a company (carrier or shipper) having a three part combination of driver, tractor and trailer available to move freight for a specified period of time (start date to end date). The system marries or joins the driver, tractor and trailer combination. The first step "joins" the driver and tractor through the asset management screens. See FIG. 3 and the associated description discussed later which more fully explains this and other features of the information system and shipping asset assignment or scheduling method.

[0050] When a shipper enters a shipment into the system the following occurs. The shipper user is directed to the capacity screen to view all capacities available in the system along with the appropriate pricing to move this load (previously, the shipper has entered the transport order, see Shipment Entry Input Table above). The Capacity Report Table is set forth below. This view or display of available shipping asset capacities uses the postal code or zip code of the pickup location (the first pickup location if a multi-pickup shipment record) to look for the nearest trailer (proximity record

search) (permanent/non-permanent trailer) matching the equipment type displayed on the capacity "choose" screen. The shipper selects the equipment or trailer or selects "all" or selects one of a trailer type in a pull down menu. Once a trailer is found or selected by the shipper (see FIG. 1 and Ship Entry Table), the nearest driver/tractor is located to that trailer (proximity search, zip code based), thus completing the three part combination of a driver-tractor-trailer required to move a shipment. The initial view or display of "capacities available" screen is based on the equipment type of the shipment thus allowing the user (typically, a shipper) to change equipment in order to view other options and pricing.

[0051] There are 2 major differences in the type of trailer, a Non Permanent Tractor/Trailer and a Permanent Tractor/Trailer. Typically most tractors have the ability to switch the trailer based on needs and the assets available to them at their terminals. These are Non Permanent Tractor/Trailers. The asset management tool herein allows for a specific tractor and specific driver to be electronically and automatically joined thus making the driver/tractor available for shipments based on their proximity to the trailer regardless of specific equipment. Email communications are used to schedule these assets. With respect to Permanent Tractor/Trailers, straight trucks are permanently attached to the tractor and can never be disconnected so technically the trailer is (ZERO) feet away from the tractor/driver combination, thus this 3 part combination (driver-tractor-trailer) will always be guaranteed.

[0052] The shipper may wish to use a specific carrier or have a favorite group of carriers. See Carrier Search Table. Further, the carrier or the shipper may want to view an available capacity report in the Capacity Report Table below.

Carrier Search Table	
Zip Code	Radius (in miles) 200
And/Or search	
Carrier Name	
City	
Equipment	

Capacity Report Table				
State	Zip	Range	Equipment	Search
Type, Equipment				
City, State, Zip				
Availability				
Destination State(s)				

[0053] When a State-to-State record (lane route) is added to the system by a carrier, the system will display a capacity to any shipper that matches a shipment pickup and delivery postal codes. In the case of a multi-stop shipment, the first and last stops are considered the pickup and delivery.

[0054] Since in a dynamic assignment mode, the system does not know where a trailer is, the pricing for mileage is calculated like all current shipments but the trailer location is considered to be at the zip code of the terminal the lane is assigned. Each State-to-State lane record is required to be tied to a specific terminal based on the Beginning Postal Code (zip code). The assumption here is that this is a non PDA/GPS equipped asset within the system thus a trailer move will not be created. If a dynamic capacity is "chosen" the system will



create a unique DRIVER, TRACTOR, and TRAILER three part combination and immediately assign the shipment to this capacity. Subsequent updates will require manual entry by the carrier, via EDI or a custom data feed, to provide status updates to the location tracking and status updates. Capacities for additional shipments will continue to appear until the shipping assets allocated has been exceeded for the specified lane. The formula for this is complex because it takes into account assignments and shipments en-route and is continually reviewing pickup and delivery schedules of active shipments (including overlaps). These aspects represent the dynamic assignment nature of the invention. At no point in time can more assets be committed than allowable. See FIG. 4 and the associated description discussed later which more fully explains this and other features of the information system and shipping asset assignment or scheduling method.

[0055] Each dynamic capacity is dissolved on delivery and the location of the capacity is no longer available. The availability comes from the "active" count being decreased by one, thus another capacity will appear again if a shipment is entered for the beginning postal code of the state-to-state lane record. The carrier running assets along a specified lane route or a shipper seeking to transport goods many times along the same or similar route may access the lane route tables below.

---

Lane Inquiry Table

---

Start Zip, End Zip, Miles, Lanes

---



---

Current Lanes and Cost Table

---

Lane  
 Start Zip, Start City, Start State  
 End Zip, End City, End State  
 Expires, Equipment Type  
 Price Dry, Price Reefer, Price Flat, Lane Cost Dry, Lane Cost Reefer,  
 Lane Cost Flat  
 Miles  
 Shipper, Numbers of Trucks in Lane

---

[0056] Spot Capacity is the quick method for carriers to enter/create a Lane Rate into the system while immediately dedicating a user defined three part asset combination capable of moving a shipment. When a Spot Capacity is created, a unique Tractor, Trailer and Driver combination are instantly created along with a Default City Pricing Lane with matching expiration dates. The Spot Capacity records cannot be edited but can be deleted while active. A spot capacity will not have a GPS/PDA installed.

---

Spot Capacity Input Table

---

Tractor Number, Equipment Type, Terminal Center  
 Dates Available for Haul Freight, From date - Time, Until date-Time  
 Location of Available Equipment, City, State, Zip  
 City Search, Range of Miles subject to search  
 User Select the preferred destination state(s) to deliver freight:  
 At least one state must be selected: pull down menu of states, - otherwise

---

-continued

---

Spot Capacity Input Table

---

City Search  
 Prices: Rate, Rate/Mile, Flat Rate

---



---

Spot Capacity Created Table

---

Crr. Company Name, Address, Phone Number, Member Since  
 Comments: Truck 521 has a Spot Rate for \$1.85 per mile from Pilot

---

[0057] The pricing engine for shipment transactions is used whenever capacity records are displayed for either a shipper or customer service for shipments in "POSTED" status. When shipments are entered by a shipper, each shipment (one per stop) also allows for a shipper to enter accessorial codes that may apply for this shipment. An accessorial is a service or feature that may optionally be provided by the carrier and such accessories represent important aspects of the decision to ship via a particular carrier. This accessorial pricing is an important aspect of the pricing structure, as the correct price of the shipment will be built based on these add-on charges supported by each carrier that has available capacity in the immediate proximity.

[0058] There are a number of critical areas a price within the system that can determine the price of a transport order based on the following hierarchy within a carrier profile to determine the correct pricing to be used. (A) Core Shipment Price: (1) Customer Specific Pricing: A carrier can create a specific lane cost and map it to a shipper if the shipper has the carrier listed as a favorite carrier in the shipper profile. Any shipment entered by a shipper that matches this lane (from and to postal code) will display the lane price when the carrier has an available capacity. (2) Lane Cost from the "From Zip" proximity to "Destination Zip" proximity: A carrier can create a lane cost based on proximity (miles) of a beginning postal code to proximity (miles) of a destination postal code. (3) Lane Rate per mile from Zip proximity to proximity: A carrier can create a lane price per mile cost based on proximity (miles) of a beginning postal code to proximity (miles) of a destination postal code. (4) State to State: If a carrier has been designated a "State to State" Dynamic Pricing carrier a "State to State" dynamic price per mile can be created that will generate a dynamic capacity up to the committed number of concurrent assets per state-to-state lane. A minimum price for each lane is supported. (5) City Default Pricing: A carrier can create a "Default City Price" lane (per mile) for a proximity to a postal code (mile) for a shipment having a beginning postal code with a destination anywhere. (6) Default price from carrier profile irrespective of commodity will be used as a stop gap price. The minimum price per shipment will also override any price that has been calculated to ensure the price is never lower than the "carrier minimum price."

[0059] Accessorial pricing is also entered into the system by the carrier. Each carrier has the ability to manage their accessorial charges to be applied to all shipments. This also applies to each individual stop within a "run" or "Line Haul". The "new load" or NL action (Carrier Selected) has a link to view all pricing prior to acceptance of the shipment. In order to financially compensate the system administrator operating the present system, the administrator (a) marks up all standard

carrier pricing by a configurable percentage and (b) bills the shipper directly and (c) pays the carrier typically within 30 days of receipt of proof of delivery. Currently an 8% system administration fee is added to each capacity price determined by the pricing engine.

[0060] Mileage Calculation for Pricing: The pricing for a non-broker supported shipment will follow the following rules for a multi-stop truckload. For every available capacity on the system that fully qualifies for consideration in moving a shipment, following rules will be applied. The standard pricing algorithm and priorities will be followed using these rules. (1) The origin and the final destination will be used to calculate the actual miles to billing purposes. (2) Each Stop added to the original shipment will have the accessorial page appear during shipment entry to allow the stop charge accessorial indicator to be flagged for the stop. This implies that carriers with accessorial stop charges configured in their profile will be calculated into the price shown on the capacity screen. If this is not configured in the accessorial screen, effectively the price will be set to 0.00 (zero). (3) All other accessorial charges input by the shipper at shipment entry will also be considered in the price. Each stop will have the ability to maintain accessorial needs. (4) The carrier profile (see carrier database 12, FIG. 1) contains the number of miles an asset will move at no extra charge to pick-up a shipment. If the shipment is farther away than the miles-willing-to-go in the profile, the extra mileage will be added to all pricing calculations using the carrier profile default price per mile value.

Booking Table			
Shipper	Pick Up State	Delivery State	Equipment
Shipper, Run, Sys Reference No., Stops, Pick Up Date, Pick Up, Delivery Date, Delivery Weight, Equipment			

Booked Shipments Table	
Shipper	Carrier
Run, Reference No., Stops, Pick Up Date, Pick Up, Delivery Date, Destination	

Shipment Status Table
Shipper, Carrier, Run sys. no.
PRO, BOL, Activity, Shipper, Shpr. Acct. Owner,
Carrier, Crr. Acct Owner
Run, BOL, PRO, Stops, Pick Up Date, Pick Up, Delivery Date,
Delivery
Broker, Details (selectable to additional linked records)
Shipment Journal (input/view log data), Status

[0061] Brokerage Pricing Shipments processed through the brokerage have a manual override to enter the amount a carrier is to be paid and the amount a shipper is required to pay the system administrator. Accessorial charges are included in the brokerage amount so no accessorial entry is considered or captured.

[0062] Salesman Commission: Commissions for every shipment have the possibility of a 4-multiple split. Currently, the following four-way split is being captured: Shipper Member Salesman Account Owner; Carrier Member Salesman Account Owner; Shipment Salesman (Shipper) who processed this particular Shipment for Split Commission; Shipment Salesman (Carrier) who processed this particular Shipment for Split Commission. Additional commissionable parties may be added for multi-leg/multi-modal transactions.

[0063] The system generates many electronic reminders or "action items" to facilitate the scheduling of shipping assets with transport orders. Action Items are created throughout the process flow based on specific events. These Actions are programmatically designed to be directed and sent to the appropriate party as an alert or action item requiring a decision to be made by the member user. Although each Action can be viewed by the system administrator, or one of its many customer service representatives (collectively identified herein as "system administrator," a singular nomenclature for many people), a number of events require the system administrator to intervene immediately. These Priority action items are part of the Customer Service or system administrator module and can be configured to generate emails to the system administrator and/or the carrier, shipper or government agency if public safety and welfare is at risk.

Action Items Table (Admin)
Shipment ID, Action Code, Date, Priority
Comments: Truck 521 has a Spot Rate for \$1.85 per mile from Pilot

[0064] The system can generate many reports and displays to track the shipment and to show the efficiency of the scheduling process. The following tables list Action items codes and list administration reports. The Code Table shows who gets the electronic communications. See FIG. 5 and the associated description discussed later which more fully explains this and other features of the information system and shipping asset assignment or scheduling method.

Advanced Reports Table
OPERATIONS: Route Activity, Lane Activity, Spot Analysis, Accepted Shipments by Date
Cancelled Shipments by Date, Company Login Activity
SALES: Sales By Date, Sales By Account Owner, Shipper Referrals
ACCOUNTING: Monthly Commission, Commission Control, Unresolved Shipments, Unresolved Completed Shipments, Daily Accounting Activity, Freight Payment Entered

Action Item Listing Table				
Action Item Code	Description	Shipper	Carrier	Sys. Admin
AS	Assign Shipper Account			X
CC	Carrier Change	X		
CD	Carrier Declined	X		
CI	Carrier Invalid			X
DA	Driver Alert			X

-continued

Action Item Listing Table				
Action Item Code	Description	Shipper	Carrier	Sys. Admin
DD	Possible Delayed Delivery	X		
DP	Possible Delayed Pickup	X		
DS	Damaged Shipment			
EI	EDI Information		X	
EM	EDI-Multiple PO's	X		
EP	EDI-PO Does Not Exist	X		
MS	Missed Stop			X
ND	New Deliver		X	
NL	New Load		X	
PC	Phantom Capacity			X
PS	Problem Shipment	X		
S1	Company Profile		X	
S2	Terminal Setup		X	
S3	User Setup		X	
S4	Driver Setup		X	
S5	Tractor Setup		X	
S6	Trailer Setup		X	
SD	Driver Swap Required		X	
TA	Tender Accepted	X		
UD	Unavailable Driver	X	X	X
VT	Video Tour	X		
ZP	Zip Default Pricing		X	

Action Code Table

AS	Assign Shipper Account: Created whenever a CS (system administrator representative) changes the internal account owner of an account (both carrier and shipper) to notify both the id owner and new owner of the change. The use of the AS action is strictly a system administrator Customer Service internal function.
CC	Carrier Change: Created when an EDI or Purchase Order data feed, indicates a shipment/PO that is already being tendered, receives a change in tender(carrier assignment), thus resulting in 2 carriers still assuming responsibility for moving a shipment.
CD	Carrier Declined: Created when a "new load" or NL Action is declined by a carrier to notify the shipper they cannot actually fulfill the movement of the shipment. The PDA supports a number of reason codes to explain and log the issue. This will require the ship to re-select available capacity is required.
CI	Carrier Invalid: EDI information from a Carrier is received that the system is not configured to process. The mapping of the EDI requires a properly mapped SCAC code to the system administrator to assure proper information processing.
DA	Driver Alert: When a Driver presses the "Alarm" button on a GPS device, the DA action is created along with email notification to Customer Service that the alarm was depressed. This will only be available on devices with an alarm button.
DD	Possible Delayed Delivery: When GPS information is received in the system and a shipment tied to this device and tractor has an expired original delivery date, a DD action is created along with an exception is posted to the shipment itself.
DP	Possible Delayed Pickup: Created when the PDA driver sends a message indicating he is delayed in picking up the shipment.
DS	Damaged Shipment: A DS Action is created to Customer Service when a shipment is marked as received-damaged in order to provide the shipper and carrier resolution options.
EI	EDI Information: Customer Service - system administrator - Internal request to initiate EDI information to a Carrier.
EM	EDI - Multiple PO's: A&P Custom Purchase Order Interface Action to identify the possibility of duplicate unique Purchase Orders.

-continued

Action Code Table

EP	EDI - PO Does Not Exist: EDI information from a Carrier is received that contains a Purchase Order Reference that is not currently in the system.
MS	Missed Stop: When GPS information is received in the SYSTEM while a carrier is delivering a line haul or run and the Delivery Geo Fence is triggered for a delivery and a previous stop has not been delivered (or en-route-arrived) an MS action is created.
ND	New Delivery: The ND action provides the dispatcher the delivery contact information in order to schedule the appointment times. Future Available Capacity is created based on the delivery appointment window plus 3 hours in order to allow unloading time.
NL	New Shipment OR New Load: Created when a shipper (or Customer Service - system administrator) chooses an available capacity to move the shipment, sending the NL action to the Carrier (dispatcher) to allow acceptance or declination of moving the shipment. Once accepted, the NL action also provided the dispatcher the pick-up contact information In order to schedule the appointment times. This also creates the ND and ZP action items.
PC	Dynamic Capacity: A PC Action is created when a capacity is chosen by a shipper for a carrier configured for State-to-State pricing and capacity control. Customer Service - system administrator - will provide Virtual Dispatcher support for the carrier. This is to be used for larger organization in order to create capacity availability quickly.
PS	Problem Shipment: A&P Custom Purchase Order Interface Action to identify inconsistencies in the data from A&P.
S1	Company Profile Video: When a new Carrier signs up in the system the Set-Up action items (S1-S6) are generated to the carrier account that can be viewed by all users within the organization until removed. Key components for initial sign-up include: Agreement Read, Insurance Coverage, Coverage States, Minimum Shipment Charge, Default Price per Mileage, Miles a driver/tractor willing to travel at carrier expense, Lane Rates and Pricing, Accessorial Pricing Information
S2	Terminal Setup Video: When a new Carrier signs up in the system the Set-Up action items (S1-S6) are generated to the carrier account that can be viewed by all users within the organization until removed. Key components for terminal set-up include: Definition of each terminal, satellite, or yard to be used as home base (responsible entity) for each asset of the organization.
S3	User Set-up Video: When a new Carrier signs up in the system the Set-Up action items (S1-S6) are generated to the carrier account that can be viewed by all users within the organization until removed. Key components for user set-up include: Security of functionality tied to "home base (terminal) for access to hierarchal information. Security Access for each User
S4	Driver Set-Up Video: When a new Carrier signs up in the system the Set-Up action items (S1-S6) are generated to the carrier account that can be viewed by all users within the organization until removed. Key components for driver set-up include: Security of functionality tied to "home base (terminal) for access to hierarchal information; Type of Driver; Driver Classification and Expiration.
S5	Tractor Set-Up Video: When a new Carrier signs up in the system the Set-Up action items (S1-S6) are generated to the carrier account that can be viewed by all users within the organization until removed. Key components for Tractor set-up include: Security of functionality tied to "home base (terminal) for access to hierarchal information; Link GPS device to specific Tractor; Permanent or Non Permanent Trailer attachment; Age of Equipment
S6	Trailer Set-Up Video: When a new Carrier signs up in the system the Set-Up action items (S1-S6) are generated to the carrier account that can be viewed by all users within the organization until removed. Key components for trailer set-up include: Security of functionality tied to "home base (terminal) for access to hierarchal information; Equipment Type

-continued

Action Code Table

SD	Driver Swap: A SD action is created when a driver with a PDA sends a "Cant Pickup". This gives the dispatcher a chance to re-direct another asset utilizing the Swap functionality of the system.
TA	Tender Accepted: A TA action is created when a pre-tendered carrier (A&P) accepts a shipment within their system.
UD	Unavailable Driver: The UD Action is created when a NL action is declined to remind carrier (dispatcher) to check on the driver in the event they are currently unavailable.
VT	Video Tour: The initial System Overview for a Carrier to provide the overall navigation and operability of the system. In addition the Set-Up action items (S1-S6) are generated to the carrier account that can be viewed by all users within the organization until removed.
US	Undeliverable Shipment: Created when the PDA driver sends a message indicating he is cannot deliver a shipment.
ZP	Zip Default Pricing: The ZP action is used to create a price per mile from a postal code (and proximity) for a short period of time. The ZP is created for each shipment (final destination) when the NL action is completed. GPS: The GPS devices, assigned to a tractor asset, deliver a continual stream of information based on the configuration of the device to our servers. This information is processed and married with the asset and shipment information within the system to offer real-time location information to determine the following within the system: Location Information; Distance Traveled; Predictive Late Arrivals; Availability Information; Door Open/Close Sensor detection to monitor load or goods on trailer; Climate/Temperature Sensor Detection; J-Buss Engine Diagnostics; Real Time and Historical Web Map Generation; By Shipment; By Asset (Start and End Times); "ALARM" (Red Button) to inform Customer Service - system administrator - of alert with all relevant information (data can feed other emergency response systems). GPS Geo Fence capability is also available to determine if an Asset has crossed within a specific proximity of a Geo Fence. Currently, the Geo Fence signal is the notification of a delivery arriving near the delivery destination. PDA APPLICATION: In order to augment the manual entry and EDI updates of shipments in the system, the asset management system allows for the assignment of a PDA to a driver and transmits pickup and delivery information to the PDA through the GPS device. The application on the PDA allows a driver to collect signatures and shipping information while en-route to seamlessly transmit these events and information to the system. This process informs the appropriate parties in the event exceptions occur while building logs for all events.

[0065] FIGS. 1-6 diagrammatically show one methodology to carry out the dynamic and predictive information system and method for assigning shipping assets.

[0066] FIG. 1 diagrammatically illustrates carrier database 12, shipper database 14 and results or shipment database 16. Carrier database 12 includes carrier contact database listing typical information such as name, address, telephone number, contact name, email, etc. Further, this information includes the name, address and contact data for each carrier terminal (Term.) or series of carrier terminals at which a plurality of shipping assets are available to that carrier. The term "carrier" includes a freight forwarder or drayage company. A carrier controls shipping assets such as drivers, tractors, trailers and/or other equipment. A carrier may have more than one terminal at which drivers, tractors and trailers originate. Carrier database 12 also includes a driver database, a tractor database and an equipment or trailer database. The Driver List Table and Add/Edit Driver Table identified above provide additional information on this topic. A tractor and/or a trailer may be equipped with a global positioning system unit or GPS unit, which, when activated, identifies the location of the

shipping asset. Further, the GPS system may be linked or coupled physically to a personal data assistant or PDA. The PDA is operated by the driver and other persons who may physically come in contact with the load or goods subject to a transport order. The PDA can store electronic shipment documents and further the PDA has an input device enabling the driver and/or the person physically at the load to annotate the electronic shipment documents. The Add/GPS Device Table listed above identifies some additional information that would be part of the carrier contact database or carrier database 12.

[0067] Carrier database 12 also includes route information defining a service area or service region serviced by the particular carrier. The route information may also include standard lane information. As is known to persons in the shipping industry, a lane is an often traveled route covered by a shipping asset. These lanes may be city to city or may be state to state lanes. Further, carrier database includes spot capacity and available capacity information records. Also, pricing information for the lanes and individual shipments and the accessorial charges is provided and logged into carrier database 12. The current lanes and cost tables set forth above are included in the carrier database 12. This information is loaded into carrier database either manually or electronically. Electronic data input or EDI is employed in some circumstances.

[0068] Shipper database 14 includes a shipper contact database listing name, address, contact information, fax, email and other information necessary to identify the shipper in the electronic space. Shippers typically have distribution centers (DC) which either receive goods or which are utilized as distribution points for goods subject to transport. The shipper database 14 also includes "favorite" carriers as well as key performance indicators or KPI profiles which are important to the shipper. The carrier may have special prices for a shipper listing the carrier as a "favorite." As discussed above in connection with the Key Performance Indicator Table, the shipper may identify whether performance is a key factor, transit time or the time to deliver a load or the price. By selecting one of five levels Low (L2) through high (H), the shipper provides a performance index which is used in the results or shipment database 16 to sort carriers subject to a transport order for goods subject to transport. Price is tie-breaker in the sort, that is, the best price is displayed first. Shipper information is input either electronically or manually.

[0069] The results or shipment database 16 handles data relative to each shipment record or transport order. The shipper typically inputs shipment entries manually or through EDI or other web based input pages. An example of the shipment input is shown above in the Shipment Entry Input Table. A shipper or carrier may request a capacity report. See the input to database 16. The Capacity Report Table set forth above is an example of such a request. Users, that is carriers, shippers, or personnel from the system administrator, may select various fields shown in the tables to search the database. Further, the carrier may request information in the form of an Asset Inquiry Table discussed above in order to determine the amount and the activities of his or her shipping assets. In addition, the carrier or the shipper may request a Capacity Inquiry and the Available Shipments Table set forth above. This is an example of this type of input in database 16. The shipper may have a favorite carrier and the shipper may conduct a Carrier Search and the Carrier Search Table set forth above represents this capacity request. Further, a ship-

per may want to transport a load of goods through a recognized shipping lane. The Lane Inquiry Table set forth above is another capacity request.

[0070] FIG. 1 shows that the results database 16 accepts EDI data, GPS data, manually entered data and PDA data.

[0071] The shipper or the carrier may have a capacity request in the form of a spot capacity input as shown in the Spot Capacity Input Table set forth above. Although typically the system operates with full truck loads, if less than full truck loads LTL are employed, the less than full truck load LTL Entry Table identified above is also a capacity request. In some situations, a shipper may want to use a less than full truck load transport order. In other situations, the carrier may have excess capacity in partially full trucks. The less than full truck loads LTL Entry Table represents such capacity request.

[0072] The results database 16 retains a record for each transport order or shipment. The Shipment Status Table set forth above lists common information for that shipment status. When a transport order or shipment is entered in the system, the system searches the database, finds shipping assets or capacities compatible with that transport order or nearly compatible with the transport order and sorts those elements primarily based on price or based on key performance indicators (KPI). The first step is the posting or listing of shipping assets which includes typically a driver-tractor-trailer combination. One of the parties, either the carrier or the shipper, is in contact with the other and the carrier has been tendered/offered the task, the shipment record is pre-booked. When a carrier agrees to accept the shipment (typically via electronic communications), the system classifies the shipment record as booked. The Booking Table set forth above is used by a carrier and/or a shipper. The Booked Shipment Table set forth above shows shipping assets that are particularly dedicated to and assigned loads or transport orders. Spot capacity is also utilized. The Spot Capacity Created Table above is identified as an output of database 16.

[0073] The results database 16 also tracks the load or goods in transit subject to the shipment record. The carrier as well as the shipper may request records from the results or shipment database 16. The Carrier Tracking Table set forth above provides an example of this type of inquiry and output. Since the shipment record may include GPS data, the GPS Device Log Table set forth above identifies some critical data which may be tracked in the shipment record. The shipment record also includes tracking shipment notes logs. These note logs can be entered by the administrator of the system and may also be entered under certain circumstances by the carrier and/or the shipper via web based input and/or the driver via a PDA. Since the results database 16 monitors the person who enters the note in the log(time, data, user name), this enables all parties who are handling or interested in that particular load transit to follow the shipment record. The Shipment Event History Table identified above shows common information relative to the entire history of the shipment in transit or the shipment record. As noted in FIG. 1, the carrier, shipper, and government agency and/or customer having an interest in the goods is able to see all or part of the shipment. Controls and passwords are used to ensure business confidentiality and privacy. Ultimately, reports can be generated by results database 16. The Advance Reports Table discussed above and the Action Item Table is employed as a communications and reporting tool. The Action Item Table is tied to the action report codes and these action report codes are generated in email messages to the carrier, shipper and/or administrators

of the system. As used herein, the term "administrator of the system" refers to many people handling the shipment and having reasonable access to the results database 16.

[0074] FIG. 2 diagrammatically shows one process and the step 20 notes that an input request has been received by the information processing system. This input request may be a shipment entry 21 or may be a capacity request 23. Step 22 searches the databases, such as the carrier database 12 or the shipper database 14 or the results database 16, and searches through the records in order to determine a number of shipping assets and capacity available for a particular transport order. The search criteria is set forth and discussed above and may include proximity to the equipment or trailer and the pick up point for the goods in relation to the destination point of the goods subject to transport. The search criteria uses a proximal location engine to search the type of equipment or trailer necessary to carry the goods subject to a specific transport order. Of course, the states serviced by a particular carrier must be included as part of the search criteria. The pick up and destination delivery data such as day for the delivery, day of the pickup is used. The drivers' days of service also are important for qualifying carriers shipping assets for selection. Step 24 compiles a capacity list showing proposed or available capacity. Step 26 sorts the list of carriers by price. Step 28 may accept a shipper selection input 27 and may sort the list of available capacity and carrier by key performance index. The Key Performance Indicator Table set forth above explains this reorganization by the process in FIG. 2 of results database 16 output.

[0075] Step 30 displays the capacity list generated either per price or per KPI. Input step 31 notes that a shipper may input a shipment entry at that location in the flowchart. The initial request if it represented a capacity request 23 would look generally for capacity for shipping assets in the system. It should be noted that the search request screens for the system are highly flexible. For example, the Capacity Report Table maybe activated based by state, by zip code, by a range or miles around a particular zip code, by equipment type (refrigerator truck, 45 foot truck, 53 foot truck, etc.) and the search may be activated by selecting the search key as noted above in the Capacity Report Table. The Available Shipments Table discussed above operates in the similar way. The user, whether a carrier or a shipper on a client computer, would select a pickup state, a delivery state, select one or more or all types of equipment (trailers) and the select search. The results database 16 would search through carrier database 12 and generate the available shipments table showing entries of carriers, stops, pickup date, pickup, delivery date, delivery, weight and equipment. In step 32, the system posts or links a particular capacity for a particular carrier with a particular shipment entry or transport order. Step 34 engages some type of communications, generally an electronic communications, between the selected carrier and the shipper seeking to utilize that capacity. Step 36 pre-books the shipping asset or capacity with the shipment order when the carrier has accepted the transport order. Step 38 recognizes that the specific carrier and the shipper submitting the transport order must agree. If not, the communications routine is again activated or an error code is generated for the system operator or system administrator. In step 40, after the shipper and carrier have accepted the transport order, the shipment record in "booked" and the carrier shipping asset is removed such that the system cannot reassign that shipping asset for the period of time subject to the transport order.

[0076] FIG. 3 diagrammatically shows the available capacity routine. Step 42 accesses the carrier asset database 12. Input step 41 recognizes that the shipper has input a "select asset" data request into the system. Step 44 electronically and automatically (without human interaction) joins equipment such as a trailer with a driver and tractor. This is the three-way combination discussed earlier. Optionally, the driver and trailer may be permanently fixed or associated with each other such that whenever a certain shipping asset is selected (a trailer) a particular designated driver follows that driver. Step 46 accepts input from the shipper as to the details of the transport request as noted by input step 47. Input step 47 has the shipper input transport parameters such as the pickup day, pickup time or range, delivery day and time or range. Step 48 accepts input from step 49 wherein the carrier inputs spot capacity data. Spot capacity data is typically a truck potentially sitting empty at a certain, non-standard location. Locations in the present system are identified by zip codes and an algorithm is utilized to locate the proximal zip codes about a target zip code. Spot capacity typically represents a shipping asset in a non-normal position. In step 48, the system typically identifies geographic limits for the shipping asset or available capacity. However, the carrier can override or reset those geographic limits as necessary. These geographic limits can be set in miles such as radius miles from a particular zip code or a particular zip code block or may be a state or city or other regional basis. Step 50 accepts input 51, carrier price override, which is optional by the carrier. In any event, step 50 identifies pricing for the particular shipment route. This pricing may be preset per mile or may be system generated or may be manually input. Pricing algorithms are discussed above. For example, in a spot capacity, the carrier may wish to charge a reduced amount of money, therefore may manually enter the spot price for that unused shipping asset. In other situations, the carrier may input standard pricing to ship goods throughout a particular state. Step 52 registers this information into the carrier database 12 and particularly in the route or capacity database. As explained earlier, a singular database may be utilized rather than multiple databases as discussed herein. The efficiency of the information processing system and the method may be improved or altered by the system designer with many databases, a single database or many indices.

[0077] FIG. 4 shows a lane capacity routine. In step 60, the carrier accesses the shipping asset database 12. Step 62 recognizes that the carrier dedicates certain units (shipping assets) at a carrier terminal to a shipping lane. A shipping lane is recognized as an often traveled or a particularly desired route between cities or between zip codes or between states. These shipping lanes are assigned pricing models such as a price per mile or a flat rate. Pricing models are discussed above. The origination is the carrier terminal or a particular carrier terminal out of many carrier terminals or user-defined origin. The destination may be a zip code, a mileage range about a certain destination zip code or may be a state. In the present invention, the carrier will provide shipping assets for a lane under the most common operation conditions. If the carrier cannot provide a shipping asset necessary to fill a transport order for a pre-set lane, there may be adverse economic consequences for the carrier reflected in KPI or handling charges. Step 64 permits the carrier to input a pickup data parameters such as location, days of operation and time and this data is calendared. Step 66 identifies the destination and calendar days as part of the lane. Step 68 identifies the destination zip code, the geographic zone about the destina-

tion, city region or state. Step 70 recognizes that the carrier must assign a pricing schedule or model to the lane or series of lanes. Step 72 registers the lane capacity in the route capacity database as part of the carrier database 12. Typically, the utilization of lane capacity employs a specific driver and a specific tractor but a non specific trailer. In other words, drivers are identified by identification numbers and tractors are identified by identification numbers and trailers are identified by identification numbers. In the pre-booked operation of the lane capacity, a non specific trailer is assigned since it is assumed that the carrier will make such equipment, such as trailer, available. The presence of a driver and a tractor is a specific asset that usually is assigned to a lane once a shipper pre-books certain shipping assets in a shipping lane.

[0078] FIG. 5 shows the administration or broker routine. Brokers assist in the completion of a transport order. Step 74 recognizes that a certain action event as been detected. The action items listed in the table above show certain action events that cause communications messages sent to the administrator as compared to the shipper and the carrier. For example, a carrier change or CC action is electronically communicated to the shipper whereas a new load NL action is electronically sent to the carrier. The unavailable driver UD action results in electronic notification going to the shipper, carrier as well as the administrator. Step 76 recognizes that these action codes are communicated to a particular party such as certain personnel in the system administration, the carrier or the shipper. Step 78 logs the event into the shipment record in the results database 16. Step 80 logs in any communication by any party and changes the record notes. Input step notes that a particular party such as a person who is part of the system administration, a carrier or shipper may input that information. Step 82 logs the event and generates a report as necessary. EDI and GPS electronic information is input in step 33 and is automatically logged into and applied to the shipment record in results database 16. When the driver utilizes a PDA, electronic documentation information in input step 85 is applied and in step the system logs in this electronic data and lists that data as part of the shipment record. This data may include a PDF file with signatures showing the acceptance of the goods subject to the transport order, the delivery of the goods and signatures of the warehouseman and the driver. Input step 87 recognizes that a government agency or other type of regulatory body as requested an input into the system and search step 86 searches the carrier database 12, the shipper data base 14 and/or the results or shipment database 16. Reports are outputted as necessary from steps 82, 84 and 86. Decision step 90 determines whether a shipment is delivered. If not, the system simply repeats and continues to gather the information and generate action reports as necessary. If the shipment has been delivered, step 92 logs the delivery event and sends a communication to the shipper. Particularly, the system will bill the shipper. Step 94 is a payment step indicating that the carrier is paid. Preferably, carriers are paid within 24 hours of the delivery. This increases the participation of the carrier into the electronic capacity allocation system. Step 96 logs the payment into the shipment database and updates the carrier's performance history. This history is used to grade and sort carriers' available capacity as discussed above. See discussion of key criteria for searching the database above.

[0079] FIG. 6 diagrammatically illustrates one example of the distributed computer system within which the information processing system and method discussed herein can be

employed. The diagram also shows one embodiment of an overall communications system to link the computer hardware system for the present invention. Internet or other communications network 1200 links a server computer 1210 having memory 1211 to the Internet. Databases 12, 14, reside on server 1210 (which may be multiple servers). Further, shippers 1 and 2 use client computers 1212 and 1214. Government or other agencies use client computer 1216. Carriers 1 and 2 use client computers 1218, 1220. Client computers 1212-1220 communicate with server 1210 (operated and maintained by the system administrator) via Internet or communications network 1200 to download information, request information regarding capacity, shipments, etc. The use of web-based input and output protocol and structure makes the computer program system independent of hardware demands. GPS units 1 and 2 are mounted in or on trucks/trailers/tractors/loads 1222 and 1224 and the GPS systems communicate with GPS satellite 1226 (representing multiple satellites and communications systems) and with GPS tracker system GPS tracker system 1228 is coupled to the Internet or communications network 1200 and information relative to the location of shipping assets 1222, 1224 is uploaded into the server 1210 maintaining the information system described earlier herein. The GPS on the trailer may include temperature sensors, data acquisition detectors and other sensors. This data may be sent with the GPS location data to the server. Further, shipping asset 1230 has a GPS unit linked to a personal electronic device or PDA. The GPS unit communicates with GPS tracker and the PDA communicates with wireless network 1232. Data from the PDA, which may include GPS data, is sent via wireless network 1232 to server 1210 via communications network 1200. The GPS data and load sensing data may be communicated independently with respect to the PDA electronic document data. It should be noted that communications network 1200 may be a wireless network using cellular communications rather than the Internet which is considered a "wired" network. The means of communications is not critical to portions of the present invention however the fact that some communications occurs between server 1210, GPS units, GPS-PDA units and various shipper and carrier client computers is important. The communications channels can change but the act of communicating is important.

[0080] FIG. 7 shows a large system diagram for the present invention. Carrier profile 110 includes information from drivers, tractors, trailers or equipment, rates and routes. Some drivers are permanently linked to tractors as described above. In such situations, when a driver or a trailer of a particular type is assigned to a shipment record in a posting sense, prior to pre-booking and booking, the driver is always permanently associated with the trailer. This information is applied into the asset management database 100. From the shipper's side, the shipper profile 112 includes origin data such as the location of goods subject to a particular transport order, destination data, that is, where the goods should be delivered, as well as private fleet and other product requirements. Product requirement simply is a particular type of equipment or trailer necessary for certain loads such as a refrigerator trailer. The system is flexible enough such that certain shippers may schedule their private fleets or privately owned shipping assets. These shippers, in this situation, act as carrier and input information in the same manner discussed above and utilize the system as a scheduling and routing program. The shippers submit a new shipment or transit order 114 into the system. The informa-

tion processing system then conducts a search and a sort routine to generate available capacity as shown in function block 116. The carrier may supply spot capacity information into functional available capacity block 116. Further, satellites obtain in GPS data from trucks and/or GPS data from PDAs (the GPS data, being mechanically coupled to the PDA, is also fed into the available capacity function 116). The output from available capacity function 116 is a booking function 118 wherein a particular shipper has agreed to utilize a particular carrier and contract for shipping assets from a particular carrier. Step 120 recognizes that a tracking function is provided by the system via the satellite and GPS and PDA inputs. The output from tracking function provides complete visibility electronically to the carrier owning and operating the shipping asset as well as the shipper having the shipment request. Further, government agencies may be interested in reviewing the shipment data. Additionally, the driver is provided with this tracking information via the PDA. Function step 122 indicates that various parties are billed and function step 124 generates reports to the shipper, the carrier, the government and the system operator as necessary.

[0081] FIGS. 8A, 8B and 8C are larger system diagrams showing data flow for one embodiment of the present invention.

[0082] FIG. 8A shows on the left hand side additional information for the carrier. The carrier may be defined by a carrier profile which lists contact data for the carrier and shipping broker data and agent data. Further, the carrier signs, in the illustrated embodiment, a contract with the system operator or administrator of the asset management program 100 such that the price of any shipment handled by the asset manager system is increased by an incremental configurable amount (currently 8% to 10%) to cover the cost of the system and generate a profit. The carrier also provides accessorial data and information and pricing information and insurance information as well as particular details regarding equipment and trailers and terminals where the shipping assets are located as well as the contact administrators for the terminals. On the right hand side of FIG. 8A, the shipper information includes shipper profile and the shipper signs an agreement with the system administrator. The system administrator provides administrative support as shown in function block 212 (carrier side) and function block 214 (shipper side). The shipper company profile includes shipper contact administrator, office location, distribution centers, store locations, personal fleet data subject to the shipping asset allocation as well as insurance. KPI inputs are also noted in FIG. 8A. A shipper inputs a new shipment record 220 (top of FIG. 8A) and also includes some route information as function block 222.

[0083] FIG. 8B is a flowchart running from asset management function block 100 to available shipment or posting function 114. On the left side, a shipping asset profile is built including type of equipment, available geographic data such as by zip code, data and time and unavailable date and time information, rate information. Additionally, spot rate capacity may be input into the system. On the right hand side, displays are shown to the carrier and the shipper as per interest level and security level. Changes are noted, the system administrator and the carrier and the shipper are permitted to edit certain details, such as to add stops and add a pickup detail. Function block 116 represents the available capacity routine. This routine is accessible by either the carrier or the shipper. Functional element 218 first matches a trailer to the new shipment entry 220, and function block 120 matches a driver



to a tractor. Pricing is matched to the transport order in function block 222. Function block 224 represents an electronic communication between an interested carrier and an interested shipper wherein the carrier and the shipper accept a new load, NL action code.

[0084] Leading to FIG. 8C, the administrator solves any open issues with respect to the matching of the transport order and the shipping asset allocation in function block 240 and communicates via carrier action items in function block 242 and shipper action items in function block 244. Email messages and alerts and instant messaging services may be employed. On the carrier side, function block 246 is a new load NL pending, function block 248 either enables the carrier to accept or decline the commitment of shipping assets and function block 250 confirms the appointment. These lead to archive function block 252, report pickup 254, report in transit, in house function 256 and report POD and signature function block 258. GPS tracking and PDA control data in function block 260 is integrated with functions 246, 248, 250, 252, 254, 256 and 258. Completed function block 262 leads to archive function block 264. A hard copy is applied to shippers/consignee/carrier freight bill/settlement function block 280. The freight bill settlement function block 280 leads to accounting function block 282 and ultimately to electronic communications data function block 284.

[0085] On the shipper side, pending new load NL function block 266 is subject to display in the view/select capacity function block 268. This leads to active function block 270 wherein the item is posted and pre-booked. Function block 272 represents that the load is in transit and function block 274 is POD. Function block 276 indicates completion of delivery and function block 277 is an archive step. Reports 278 are available from both the carrier and the action side.

[0086] Since many modifications, variations and changes in detail can be made to the described preferred embodiment of the invention, it is intended that all matters in the foregoing description and shown in the accompanying drawings be interpreted as illustrative and not in a limiting sense. Thus, the scope of the invention should be determined by the appended claims and their legal equivalents.

[0087] Now that the invention has been described,

What is claimed is:

1. A method for electronically assigning shipping assets to goods subject to transport orders, said shipping assets including a plurality of drivers, tractors and trailers from a plurality of carriers and said goods subject to a plurality of said transport orders from a plurality of shippers, comprising:

maintaining a database with data representing respective shipping assets associated with corresponding carriers some of which are lane route carriers, each lane carrier having at least one terminal from which respective shipping assets originate and route lanes between a corresponding lane carrier terminal and a corresponding termination location and a respective pricing schedule;

electronically accepting a specific transport order for goods from one shipper, said specific transport order having ship from origin and a ship to destination geographically proximal to respective terminals and termination locations for a sub-plurality of carriers;

electronically joining, for said specific transport order and for each carrier of said sub-plurality of carriers, a respective combination of a driver, a tractor and a trailer able to transport said goods;

electronically selecting, sorting and displaying by price, carriers within said sub-plurality of carriers based upon a plurality of search criteria including close proximity of corresponding terminals and termination locations to ship origin and ship destination, and pick-up and delivery constraints;

in conjunction with an electronic communication with one of the selected carriers and said one shipper, booking and electronically logging said one selected carrier and the associated joined driver-tractor-trailer combination to fill said transport order for said goods.

2. A method for electronically assigning shipping assets as claimed in claim 1 wherein said carriers are commercially independent of each other.

3. A method for electronically assigning shipping assets as claimed in claim 1 wherein a further sub-plurality of drivers are permanently assigned to a respective further sub-plurality of tractors, which are designated as permanently joined driver-tractor combinations, and wherein electronically selecting said sub-plurality of carriers includes a search for the close proximity permanently joined driver-tractor combinations to said ship origin.

4. A method for electronically assigning shipping assets as claimed in claim 1 wherein electronically joining occurs automatically without user intervention.

5. A method for electronically assigning shipping assets as claimed in claim 1 wherein said electronically selecting, sorting and displaying includes a user activated sort by historic performance rating which includes one or both of historic on-time delivery data and adverse delivery event data.

6. A method for electronically assigning shipping assets as claimed in claim 1 wherein said electronic communication includes email notification or instant messaging service notification.

7. A method for electronically assigning shipping assets as claimed in claim 1 wherein said selecting, sorting and display results in a posting of specific shipping assets for respective carriers and the method includes multiple postings for the same specific shipping asset.

8. A method for electronically assigning shipping assets as claimed in claim 1 wherein electronically joining joins a specific driver and a specific tractor but joins a non-specific trailer for said sub-plurality of carriers.

9. A method for electronically assigning shipping assets as claimed in claim 2 wherein a further sub-plurality of drivers are permanently assigned to a respective further sub-plurality of tractors, which are designated as permanently joined driver-tractor combinations, and wherein electronically selecting said sub-plurality of carriers includes a search for the close proximity permanently joined driver-tractor combinations to said ship origin.

10. A method for electronically assigning shipping assets as claimed in claim 9 wherein electronically joining occurs automatically without user intervention.

11. A method for electronically assigning shipping assets as claimed in claim 10 wherein said electronically selecting, sorting and displaying includes a user activated sort by historic performance rating which includes one or both of historic on-time delivery data and adverse delivery event data.

12. A method for electronically assigning shipping assets as claimed in claim 11 wherein said electronic communication includes email notification or instant messaging service notification.



13. A method for electronically assigning shipping assets as claimed in claim 12 wherein said selecting, sorting and display results in a posting of specific shipping assets for respective carriers and the method includes multiple postings for the same specific shipping asset.

14. A method for electronically assigning shipping assets as claimed in claim 13 wherein electronically joining joins a specific driver and a specific tractor but joins a non-specific trailer for said sub-plurality of carriers.

15. A method for electronically assigning shipping assets to goods subject to transport orders, said shipping assets including a plurality of drivers, tractors and trailers from a plurality of carriers and said goods subject to a plurality of said transport orders from a plurality of shippers, some drivers and tractors and trailers having global positioning units which locate said tractor and trailer shipping assets and personal data assistants which electronically display and capture electronic shipping documents and data relative to said electronic shipping documents, the method comprising:

maintaining a database with data representing respective shipping assets associated with corresponding carriers, and data relative to each carrier having at least one terminal from which respective shipping assets originate and transport service areas and a respective pricing schedule, and data from global positioning units of drivers and tractors and trailers and data from personal data assistants which electronically document said electronic shipping documents;

electronically accepting a specific transport order for goods from one shipper, said specific transport order having ship from origin and a ship to destination geographically proximal to respective service areas for a sub-plurality of carriers;

electronically joining, for said specific transport order and for each carrier of said sub-plurality of carriers, a respective combination of a driver, a tractor and a trailer able to transport said goods;

electronically selecting, sorting and displaying by price, carriers within said sub-plurality of carriers based upon proximity of corresponding terminals to ship origin and pick-up and delivery constraints;

in conjunction with an electronic communication with one of the selected and displayed carriers and said one shipper, booking and electronically logging said one selected carrier and the associated joined driver-tractor-trailer combination to fill said transport order for said goods; and

electronically accepting data from the joined driver-tractor-trailer combination for the one selected carrier and corresponding global positioning unit and personal data assistant to electronically document transit of the fulfillment of said transport order for said goods.

16. A method for electronically assigning shipping assets as claimed in claim 15 wherein said carriers are commercially independent of each other.

17. A method for electronically assigning shipping assets as claimed in claim 15 wherein said global positioning unit is coupled to a respective personal data assistant and the coupled global positioning unit—personal data assistant is removably mounted in a respective tractor.

18. A method for electronically assigning shipping assets as claimed in claim 15 wherein electronically joining occurs automatically without user intervention.

19. A method for electronically assigning shipping assets as claimed in claim 15 wherein said electronically selecting, sorting and displaying includes a user activated sort by historic performance rating which includes one or both of historic on-time delivery data and adverse delivery event data.

20. A method for electronically assigning shipping assets as claimed in claim 15 wherein said electronic communication includes email notification or instant messaging service notification.

21. A method for electronically assigning shipping assets as claimed in claim 15 wherein said selecting, sorting and display results in a posting of specific shipping assets for respective carriers and the method includes multiple postings for the same specific shipping asset.

22. A method for electronically assigning shipping assets as claimed in claim 16 wherein said global positioning unit is coupled to a respective personal data assistant and the coupled global positioning unit—personal data assistant is removably mounted in a respective tractor.

23. A method for electronically assigning shipping assets as claimed in claim 22 wherein electronically joining occurs automatically without user intervention.

24. A method for electronically assigning shipping assets as claimed in claim 23 wherein said electronically selecting, sorting and displaying includes a user activated sort by historic performance rating which includes one or both of historic on-time delivery data and adverse delivery event data.

25. A method for electronically assigning shipping assets as claimed in claim 24 wherein said electronic communication includes email notification or instant messaging service notification.

26. A method for electronically assigning shipping assets as claimed in claim 25 wherein said selecting, sorting and display results in a posting of specific shipping assets for respective carriers and the method includes multiple postings for the same specific shipping asset.

27. An information processing system for electronically assigning shipping assets to goods subject to transport orders, said shipping assets including a plurality of drivers, tractors and trailers from a plurality of carriers and said goods subject to a plurality of said transport orders from a plurality of shippers, comprising:

a central computer linked, via a communications network, to a plurality of user computers, said corresponding user computers under the control of said respective carriers of said plurality of carriers and respective shippers of said plurality of shippers;

a database on said central computer with data representing respective shipping assets associated with corresponding carriers some of which are lane route carriers, each lane carrier having at least one terminal from which respective shipping assets originate and route lanes between a corresponding lane carrier terminal and a corresponding termination location and a respective pricing schedule, said database containing data representing respective terminals, route lanes and termination locations and pricing schedules for corresponding carriers;

means for electronically accepting a specific transport order for goods from a respective use computer for one shipper, said specific transport order having ship from origin and a ship to destination geographically proximal to respective terminals and termination locations for a sub-plurality of carriers;

at said central computer, a search engine for locating in said database and means for electronically joining, for said specific transport order and within said sub-plurality of carriers, a respective combination of a driver, a tractor and a trailer able to transport said goods subject to said transport order;

a further search engine at said central computer electronically selecting and sorting by price, carriers within said sub-plurality of carriers based upon close proximity of corresponding terminals and termination locations to ship origin and ship destination, and pick-up and delivery constraints;

means for displaying to said users via said central computer and user computers over said communications network the selected and sorted sub-plurality of carriers and respective pricing for respective carriers in said sub-plurality of carriers; and

an electronic communications means, operable with a user computer for a selected carrier of said sub-plurality of carriers and a user computer for said one shipper with said specific transport order, for booking and electronically logging said one selected carrier and the associated joined driver-tractor-trailer combination to fill said transport order for said goods.

28. An information processing system for electronically assigning shipping assets as claimed in claim 27 wherein said carriers are commercially independent of each other.

29. An information processing system for electronically assigning shipping assets as claimed in claim 27 wherein said database includes data representing historic performance for said shippers including historic on-time delivery data and adverse delivery event data and said further search engine sorts carriers within said sub-plurality of carriers based upon one or the other or both said historic on-time delivery data and adverse delivery event data.

30. An information processing system for electronically assigning shipping assets as claimed in claim 27 wherein said electronic communication means includes an email system or an instant messaging system.

31. An information processing system for electronically assigning shipping assets as claimed in claim 28 wherein said database includes data representing historic performance for said shippers including historic on-time delivery data and adverse delivery event data and said further search engine sorts carriers within said sub-plurality of carriers based upon one or the other or both said historic on-time delivery data and adverse delivery event data.

32. An information processing system for electronically assigning shipping assets as claimed in claim 31 wherein said electronic communication means includes an email system or an instant messaging system.

33. An information processing system for electronically assigning shipping assets to goods subject to transport orders, said shipping assets including a plurality of drivers, tractors and trailers from a plurality of carriers and said goods subject to a plurality of said transport orders from a plurality of shippers, some drivers and tractors and trailers having global positioning units which locate said tractor and trailer shipping assets and personal data assistants which electronically display and capture electronic shipping documents and data relative to said electronic shipping documents, the system comprising:

a central computer linked, via a communications network, to a plurality of user computers, said corresponding user

computers under the control of said respective carriers of said plurality of carriers and respective shippers of said plurality of shippers;

said central computer further linked, via a communications network, to the plurality of global positioning units and personal data assistants such that location data and electronic shipping document data is shared with said central computer and with said user computers;

a database on said central computer with data representing respective shipping assets associated with corresponding carriers, and data relative to each carrier having at least one terminal from which respective shipping assets originate and transport service areas and a respective pricing schedule, and data from global positioning units of drivers and tractors and trailers and data from personal data assistants which electronically documents said electronic shipping documents;

means for electronically accepting a specific transport order for goods from one shipper, said specific transport order having ship from origin and a ship to destination geographically proximal to respective service areas for a sub-plurality of carriers;

at said central computer, a search engine for locating in said database and means for electronically joining, for said specific transport order and for carriers in said sub-plurality of carriers, a respective combination of a driver, a tractor and a trailer able to transport said goods;

a further search engine at said central computer electronically selecting and sorting by price, carriers within said sub-plurality of carriers based upon close proximity of corresponding terminals and termination locations to ship origin and ship destination, and pick-up and delivery constraints;

means for displaying to said users via said central computer and user computers over said communications network the selected and sorted sub-plurality of carriers and respective pricing for respective carriers in said sub-plurality of carriers; and

an electronic communications means, operable with a user computer for a selected carrier of said sub-plurality of carriers and a user computer for said one shipper with said specific transport order, for booking and electronically logging said one selected carrier and the associated joined driver-tractor-trailer combination to fill said transport order for said goods; and

means for electronically accepting data from the joined driver-tractor-trailer combination for the one selected carrier and corresponding global positioning unit and personal data assistant to electronically document transit of the fulfillment of said transport order for said goods.

34. An information processing system for electronically assigning shipping assets as claimed in claim 33 wherein said carriers are commercially independent of each other.

35. An information processing system for electronically assigning shipping assets as claimed in claim 33 wherein said global positioning unit is coupled to a respective personal data assistant and the coupled global positioning unit—personal data assistant is removably mounted in a respective tractor.

36. An information processing system for electronically assigning shipping assets as claimed in claim 33 wherein said database includes data representing historic performance for said shippers including historic on-time delivery data and adverse delivery event data and said further search engine sorts carriers within said sub-plurality of carriers based upon

one or the other or both said historic on-time delivery data and adverse delivery event data.

37. An information processing system for electronically assigning shipping assets as claimed in claim 33 wherein said

electronic communication means includes an email system or an instant messaging system.

\* \* \* \* \*

8

Alessio

U.S. Patent No. 8,649,775



US008649775B2

(12) **United States Patent**  
Alessio et al.

(10) **Patent No.:** US 8,649,775 B2  
(45) **Date of Patent:** Feb. 11, 2014

(54) **ACQUISITION OF A VOICE SIGNATURE FOR STATUS TRACKING AND PROOF OF DELIVERY OF SHIPPED GOODS**

(75) Inventors: **Eduardo Alessio, Austin, TX (US); Pedro Landa, Austin, TX (US)**

(73) Assignee: **uFollowit, Inc., Austin, TX (US)**

(\* ) Notice: Subject to any disclaimer, the term of this patent is extended or adjusted under 35 U.S.C. 154(b) by 1194 days.

(21) Appl. No.: **12/344,587**

(22) Filed: **Dec. 28, 2008**

(65) **Prior Publication Data**  
US 2009/0170482 A1 Jul. 2, 2009

**Related U.S. Application Data**  
(60) Provisional application No. 61/017,497, filed on Dec. 28, 2007.

(51) **Int. Cl.**  
*H04M 3/42* (2006.01)

(52) **U.S. Cl.**  
USPC ..... **455/414.1**

(58) **Field of Classification Search**  
USPC ..... 455/414  
See application file for complete search history.

(56) **References Cited**  
U.S. PATENT DOCUMENTS

5,313,051 A \* 5/1994 Brigida et al. .... 235/375  
6,433,732 B1 \* 8/2002 Dutta et al. .... 342/357.46

6,467,688 B1 \* 10/2002 Goldman et al. .... 235/472.01  
2001/0043273 A1 \* 11/2001 Herrod et al. .... 348/220  
2005/0232189 A1 \* 10/2005 Loushine ..... 370/328  
2005/0289008 A1 \* 12/2005 Olivier et al. .... 705/22  
2007/0005452 A1 \* 1/2007 Klingenberg et al. .... 705/27  
2008/0133659 A1 \* 6/2008 Aldrey et al. .... 709/204  
2008/0255758 A1 \* 10/2008 Graham et al. .... 701/209  
2009/0287483 A1 \* 11/2009 Co et al. .... 704/231

**FOREIGN PATENT DOCUMENTS**

WO WO 2008/057133 \* 5/2008 ..... H04Q 7/20  
\* cited by examiner

*Primary Examiner* — Kwasi Karikari  
(74) *Attorney, Agent, or Firm* — Michael J Williams

(57) **ABSTRACT**

A method used in the acquisition of a voice signature associated with the status or tracking of shipped goods is provided. The method includes initiating a call and/or data communication between a remote user and/or device and a shipment tracking system and vice versa. The call and/or data communication is then associated with a shipment. A status of the shipment is determined and a time stamp is assigned to the call. A digital voice recording is generated and if a delivery event a voice signature is acquired during the call. The voice signature is stored to the remote tracking system wherein the voice signature is associated with the shipment, shipment status and time stamp. The voice signature is transformed to text, wherein the text is associated with the voice signature. Finally an electronic shipment status based on the voice signature, text associated with the voice signature, the shipment, shipment status and time stamp is provided. The location of the event is acquired via GPS and/or cellular tower servicing the device, location, and or transforming the voice recording of an event into a latitude and longitude location and or town, city, state and/or country of event.

**14 Claims, 10 Drawing Sheets**

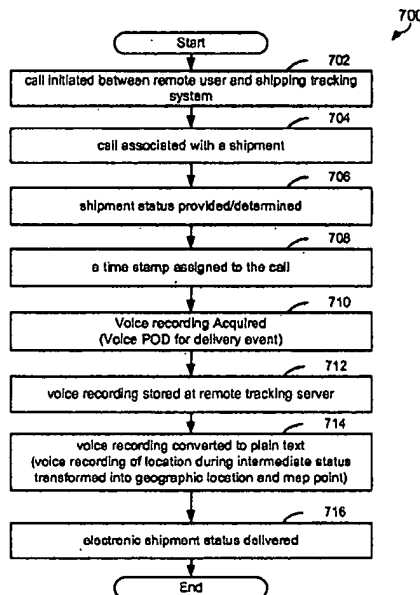

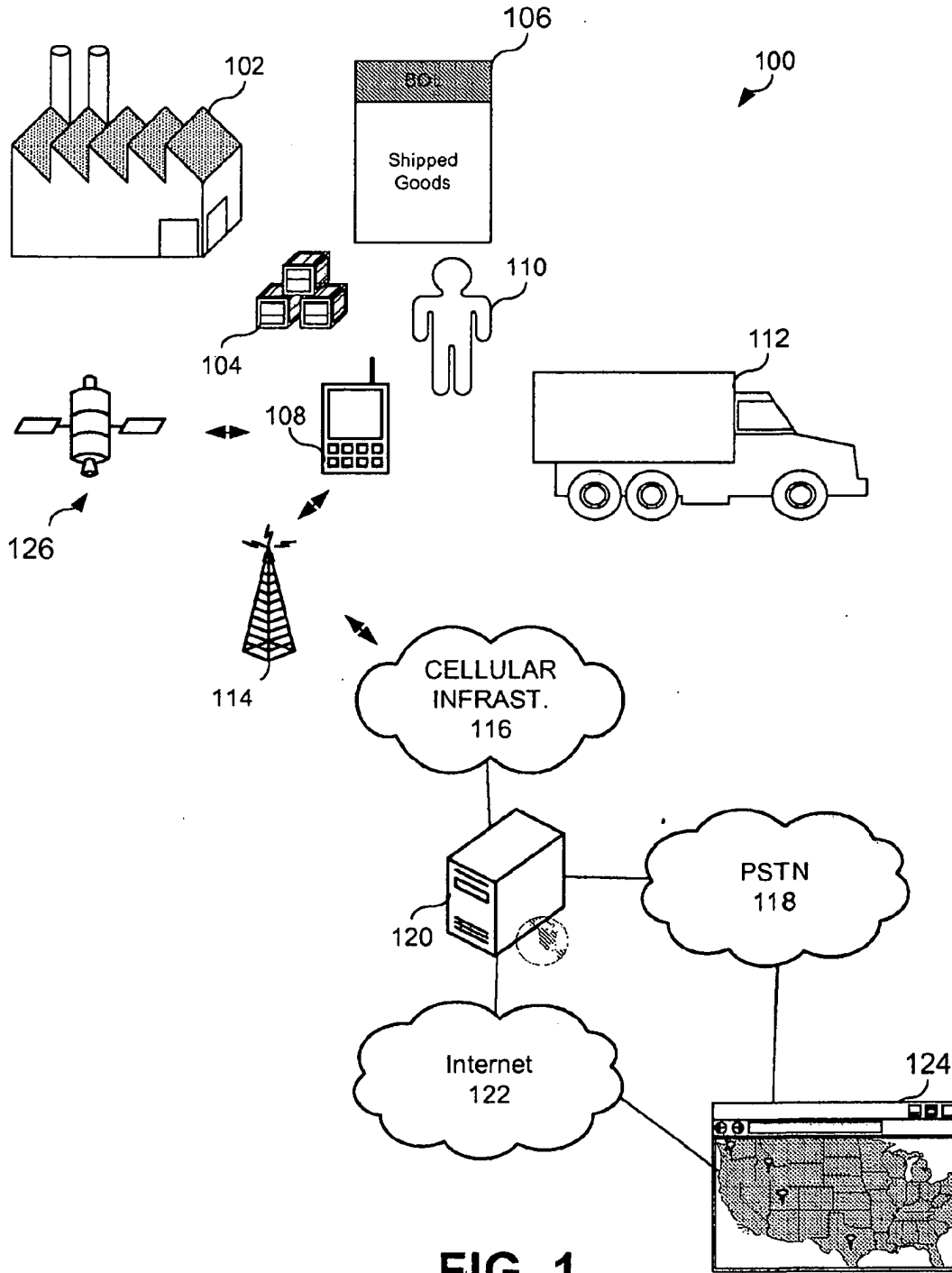

FIG. 1

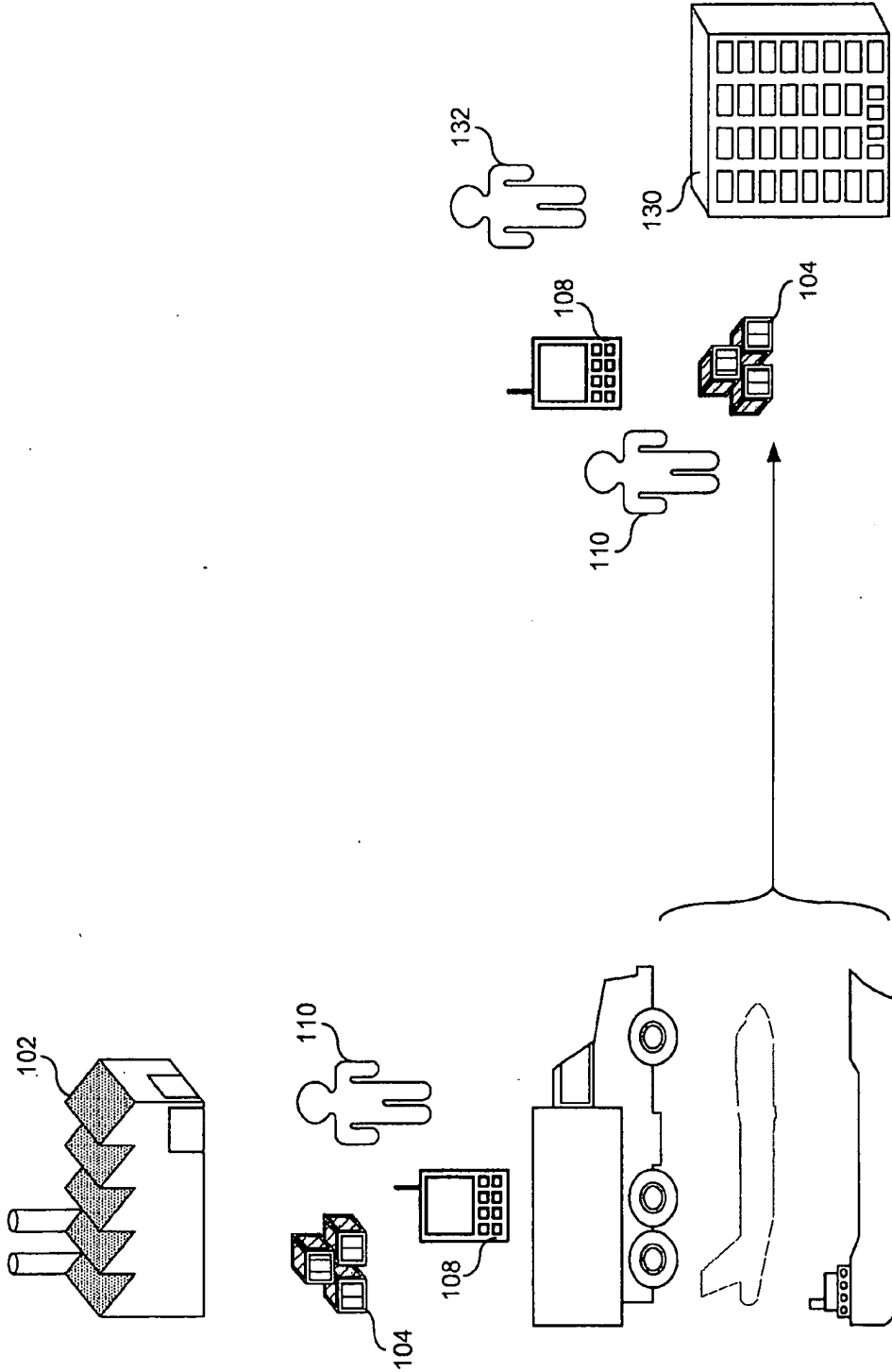

FIG. 2

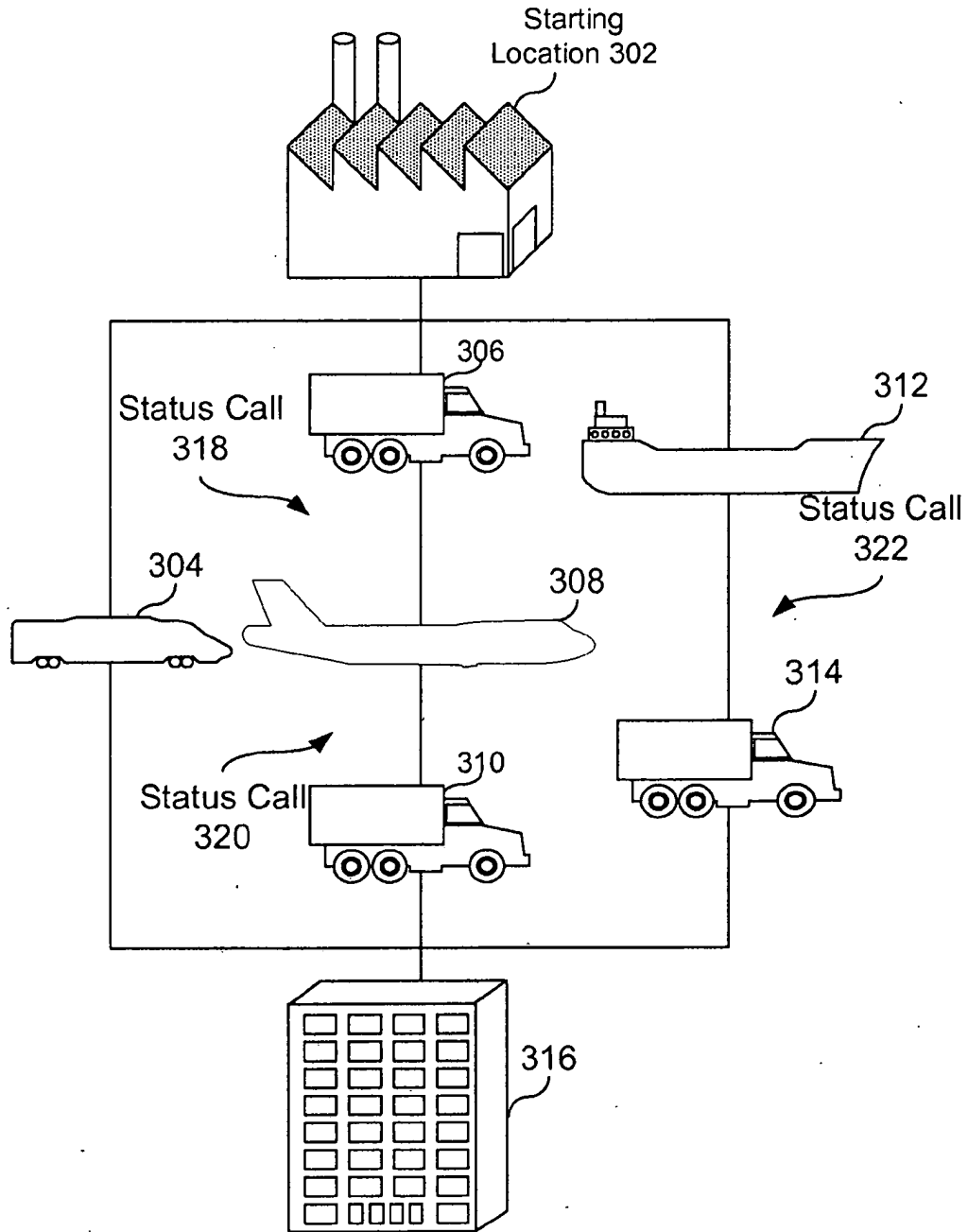

FIG. 3



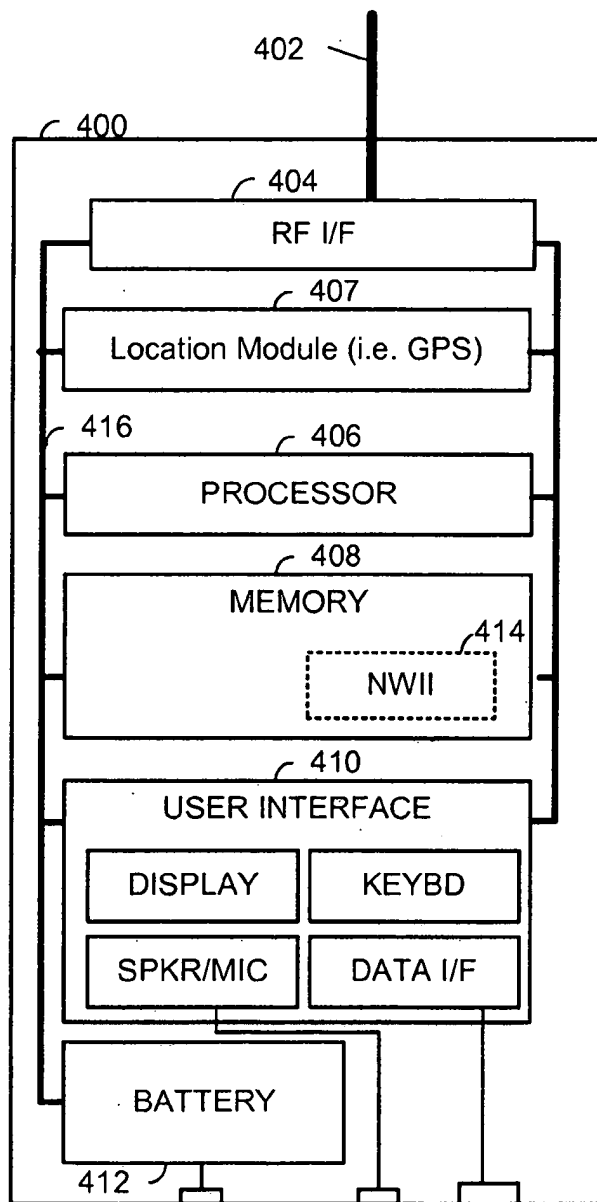
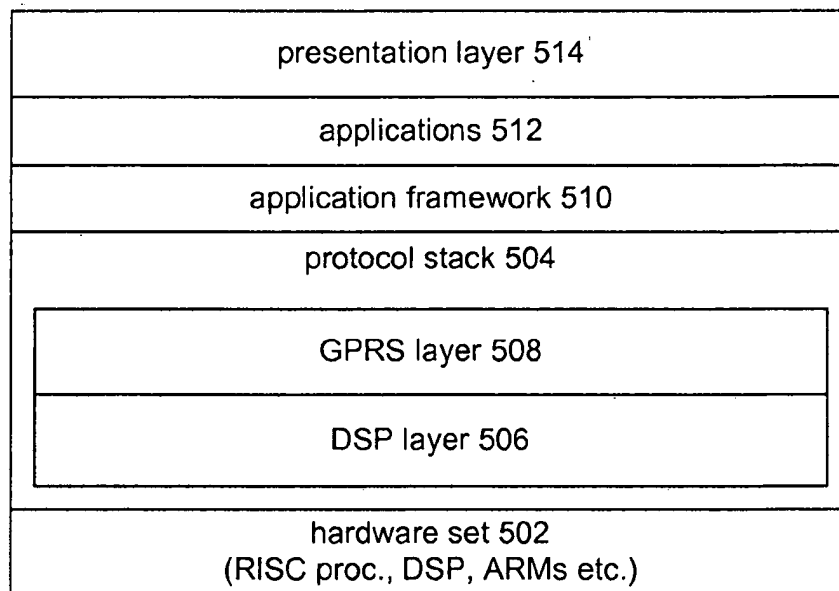

FIG. 4



**FIG. 5**

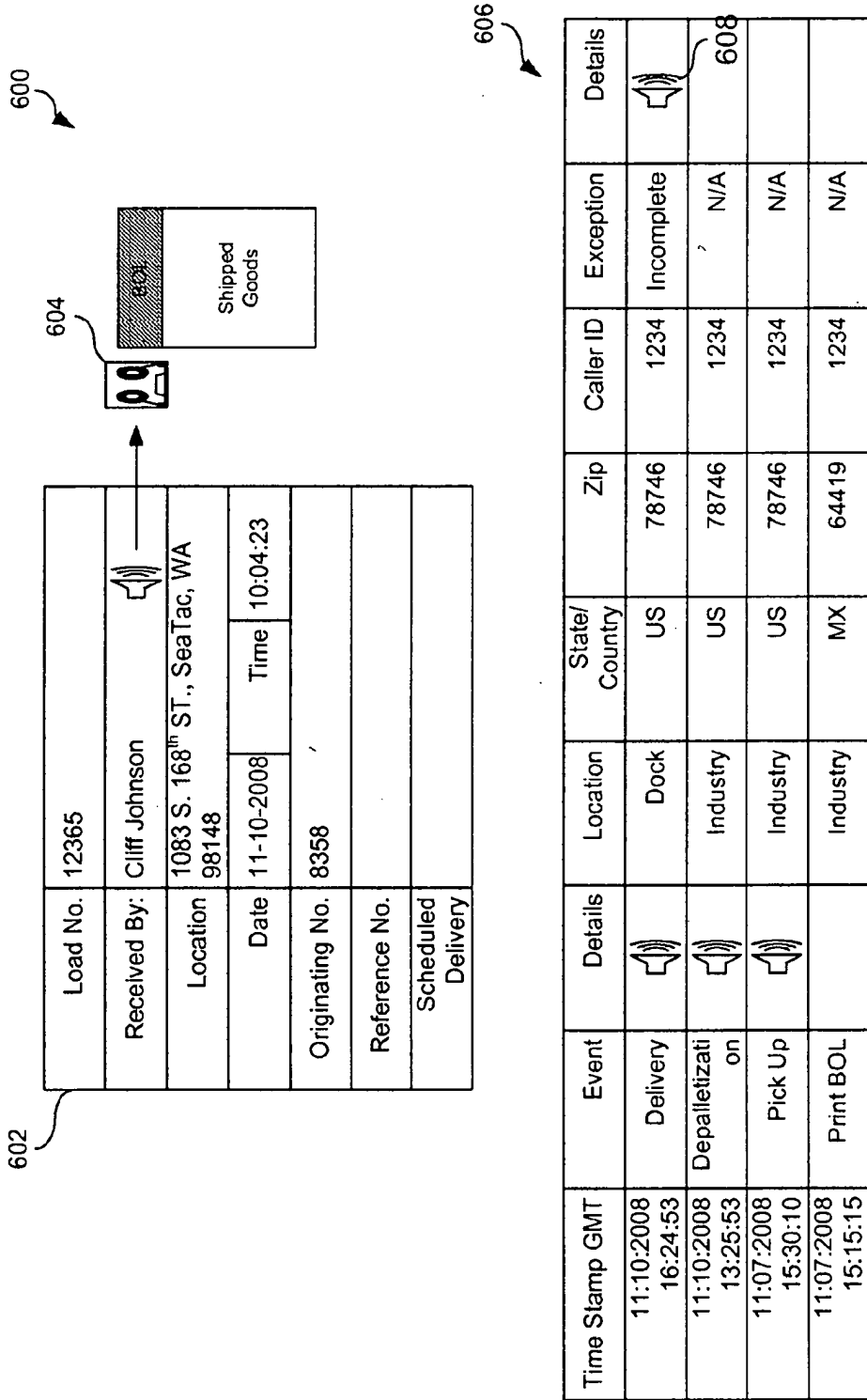

FIG. 6A

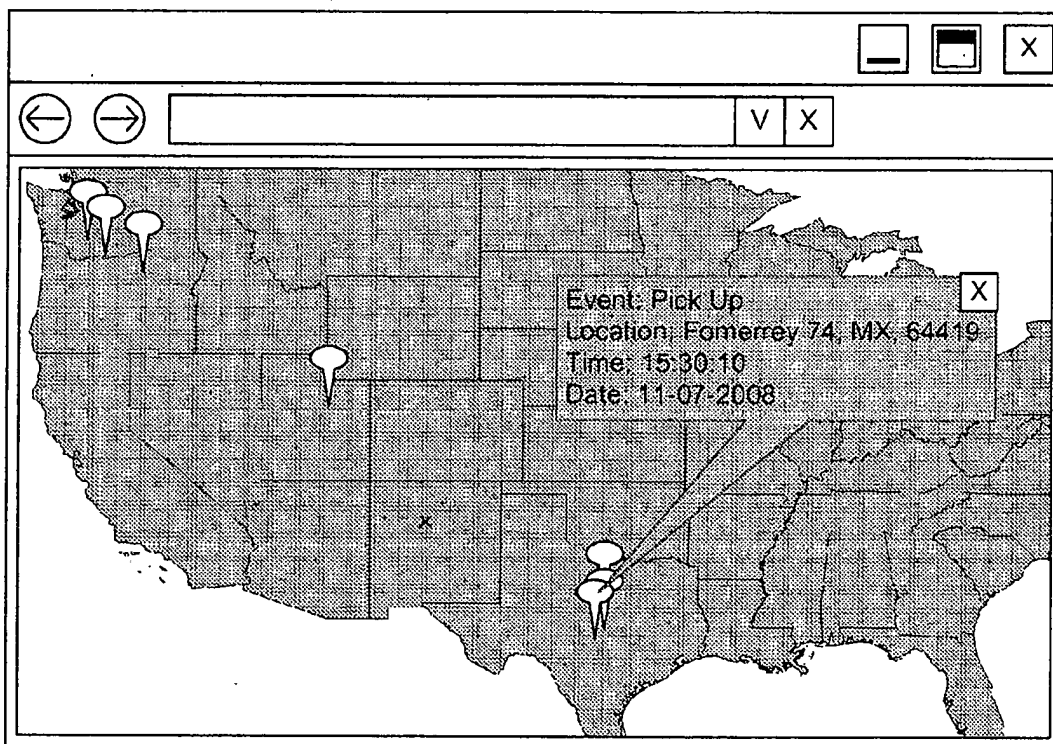

FIG. 6B

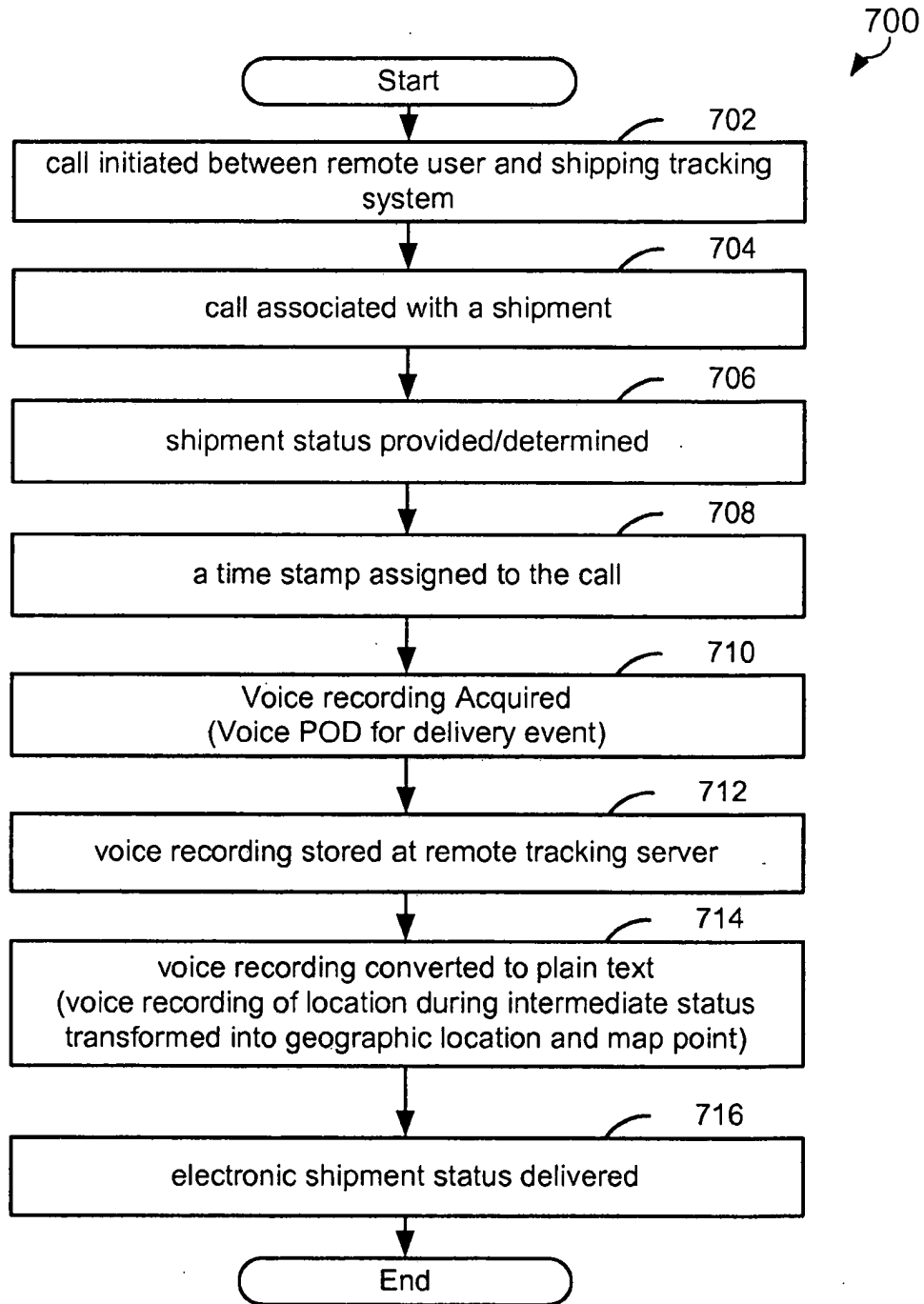

FIG. 7

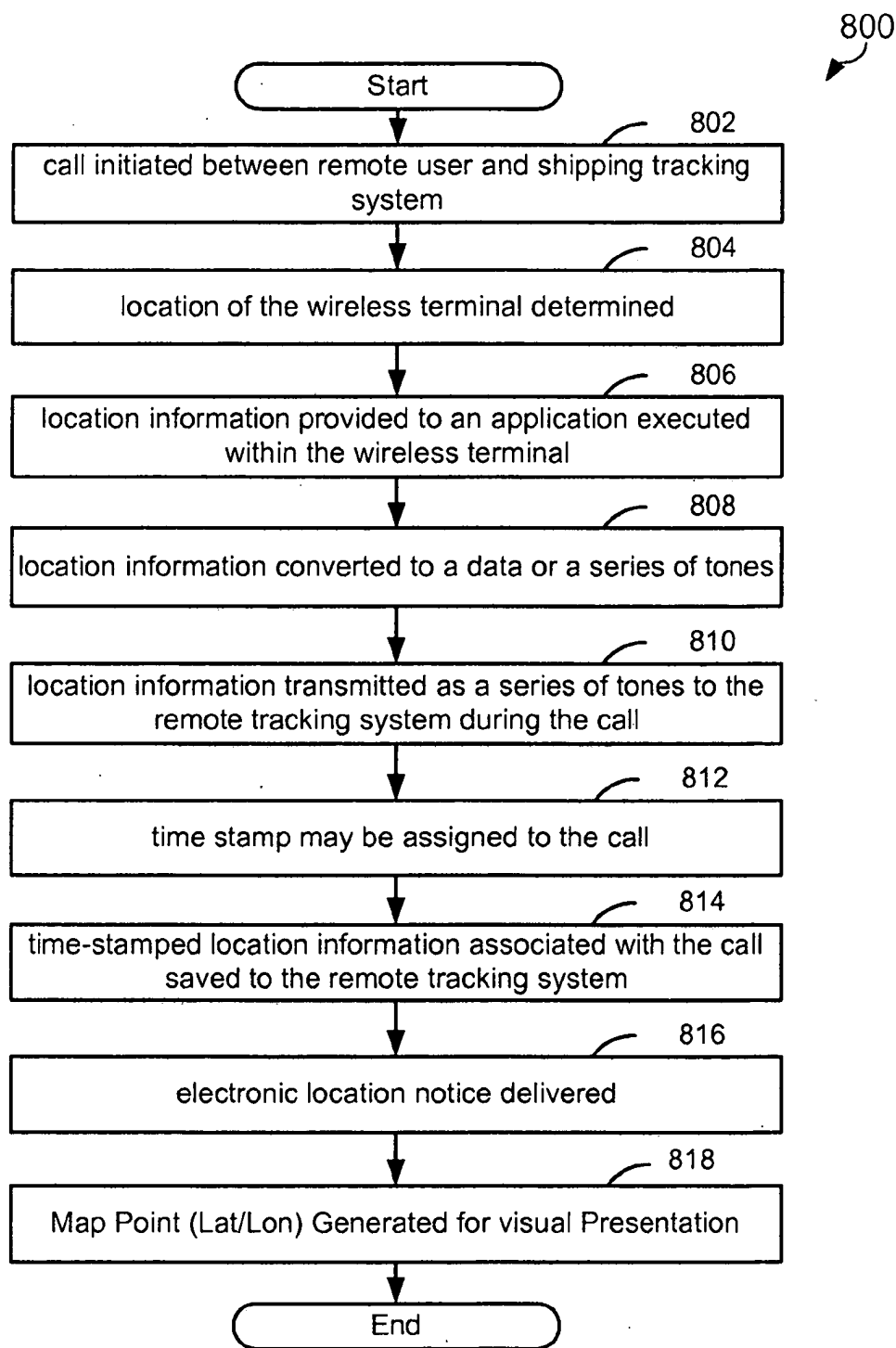
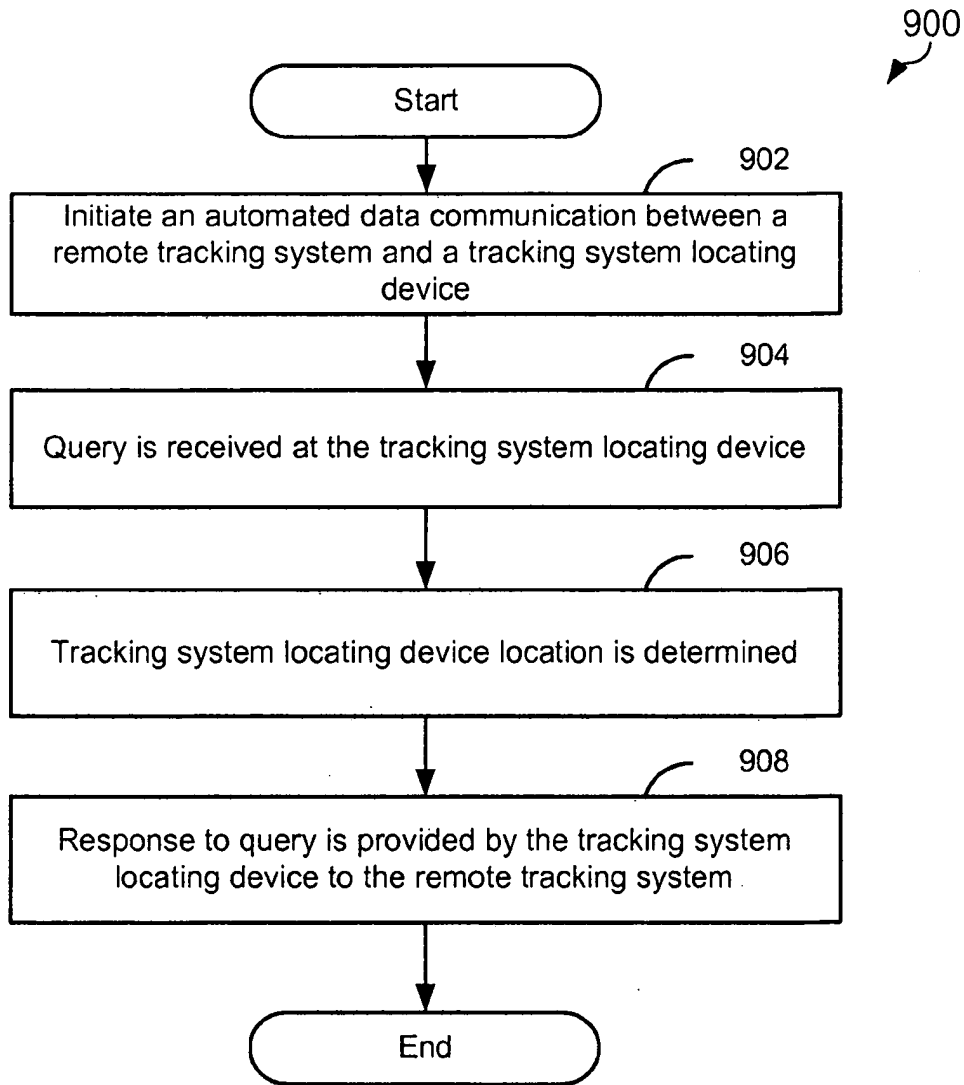

FIG. 8



**FIG. 9**

ACQUISITION OF A VOICE SIGNATURE FOR STATUS TRACKING AND PROOF OF DELIVERY OF SHIPPED GOODS

CROSS-REFERENCE TO RELATED APPLICATIONS

The present U.S. Utility Patent Application claims priority pursuant to 35 U.S.C. §119(e) to the following U.S. Provisional Patent Application which is hereby incorporated herein by reference in their entirety and made part of the present U.S. Utility Patent Application for all purposes:

1. U.S. Provisional Application Ser. No. 61/017,497, entitled "SYSTEM AND METHOD FOR PROVIDING VOICE PROOF OF DELIVERY AND TRACKING OF SHIPPED GOODS," filed Dec. 28, 2007, pending.

FIELD OF THE INVENTION

The present invention relates generally to the tracking of shipped goods, and more particularly, a system and method for providing real time voice based location and proof-of-delivery (POD) of shipped goods.

BACKGROUND OF THE INVENTION

The parcel and small package delivery industry has become accustomed to providing a text based proof-of-delivery (POD) service, and in a lesser frequency, a signed POD. Such activities are generally performed with the use of a handheld device equipped with a bar code scanner, where the package identification number is scanned and the consignee name is typed into a parcel delivery record. Sometimes, when the consignee is available and the service provider provides the service, the name of the consignee or a signed POD might be acquired. This type of POD and the use of handheld devices are justified for the sorting, handling and delivery of parcel and small packages, because each route can deliver on the order of tenths or hundreds parcels per route. Hence, the volume justifies the cost of acquiring such POD with such devices and the software that runs on these devices.

For the freight industry, however, such handheld devices are rarely justified since trucks, the most common means of transportation and delivery, usually perform a single stop to delivery a full truck load, or perform a very small number of delivery stops for a Less than a Truck Load (LTL). Therefore, the use of handheld devices in this industry is cost prohibitive and not done. In addition, the 3<sup>rd</sup> party carriers or independent drivers who perform the task of transporting such loads, and hence do not have such handheld devices, nor have the proper training to operate each particular application running on such devices.

The way truck drivers and delivery personnel who delivery loads send the POD to their dispatching areas and customers is generally by two ways.

In the first way, the delivery person calls the dispatching center and verbally reports the date and time of the delivery. The problem with this method is that the verbal report is not typically recorded and is subject to incompleteness, inaccuracies, lateness and/or volatility

Alternatively, the delivery person acquires signed the Bill of Lading (BOL) documentation, by the consignee, and returns the BOL by regular mail or small package delivery services back to the shipper. The problem with this method of providing POD is the amount of time required to return the signed BOL to the shipper, plus the expense to do so. This time delay causes long delays to invoice customers and longer

delays to collect payment. Other problems include lack of visibility and lack of information to provide customers on the where about of their freight which translates in multiple calls into the shipper's and broker's customer service, costing them hundreds of thousands of dollars per year.

Problems facing the logistics and distribution industries include (1) need to track shipments and provide accurate and reliable POD; (2) lack of visibility of shipments; (3) high costs to track load status; (4) long times to invoice and collect monies; and (5) high costs on customer services (6) high cost to maintain a network of handheld devices as well as the proper versions of the software applications running on them

BRIEF SUMMARY OF THE INVENTION

Embodiments of the present invention are directed to systems and methods that are further described in the following description and claims. Advantages and features of embodiments of the present invention may become apparent from the description, accompanying drawings and claims.

The present invention pertains to fields of logistics, transportation, supply chain, distribution and customs. Particularly, embodiments pertain to the tracking the movement of shipped goods along the supply chain, where shipments, freight, cargo, loads or packages need to be picked up and upon delivery confirmed by a consignee. This tracking and confirmation provides visibility and proof-of-delivery (POD) to the participating parties, the shipper, the broker, the transportation agent and the receiving party.

One embodiment of the present invention provides a method used in the acquisition of load status and of a voice signature POD associated with the status or tracking of shipped goods. The method includes initiating a call between a remote user and a shipment tracking system, either initiated by the driver transporting the good to report the good's status and/or to acquire the POD, or initiated by an automated system that calls the driver to acquire the good's current status and location. The call is then associated with a shipment via a shipping number or other identifier. A status of the shipment is determined and a time stamp is assigned to the call. A digital voice recording and/or a digital voice signature of the POD is acquired during the call. The voice recording and/or signature is stored at the remote tracking system wherein the recording is associated with every event type, this being pickup, delivery, status call, or any other, of the shipment, in conjunction with the shipment status and time stamp as well as event incident exception if any. The voice recording of the voice signature is transformed to text, wherein the text is also associated with the shipment as a visual and readable name of the consignee receiving the freight, which on the tracking service is attached to the original voice recording of the POD associated with the voice signature, the shipment, shipment status and time stamp is provided.

Another embodiment of the present invention provides method of gathering location information associated with a wireless device, terminal and/or phone. This method involves initiating a call between a wireless terminal and a remote tracking system. The location of the wireless terminal is determined. This determination may be done at the wireless terminal using information associated with the cellular infrastructure if the wireless terminal is a cellular phone, GPS information if the wireless terminal is GPS enabled, or location information associated with an IP address when the wireless terminal is a VOIP or WLAN type device. This location information may then be converted to an audible signal such as a series of tones using an application executed within the upper protocol stack of the wireless terminal. The location



3

information may then be transmitted audibly to the remote tracking system during the call. A time stamp and location stamp are produced by the remote tracking system. This set of information is stored to the remote tracking system and is associated with other information that may be part of the call such as shipment information, POD information and other like information.

Other embodiments of the present invention relate to a shipment tracking system. The shipping tracking system includes software instructions that may be executed on a remote server; a delivery network; and one or more communication devices, terminals or wireless terminals. The delivery network picks up, transports and delivers goods associated with the shipment. The wireless device, terminal and/or phone maintained by a user associated with the delivery network, may support a data communication established between the wireless terminal and the shipping tracking system. The data communication may be initiated by either side. This allows the device to provide shipment status and location information associated with the shipment to the tracking system in response to queries from the remote tracking system during a short data communication. Status information may include but it is not limited to a shipment identifier, a shipment status, a time stamp, location, geospatial latitude, geospatial longitude and/or digital voice recording such as a voice signature for a custody transfer of the goods. The remote tracking system stores the status information including the digital voice recording and voice signature text and converts the voice recording to the voice signature text and provides an electronic shipment status based on the shipment status information.

Other embodiments of the present invention relate to a device attached to the freight which through a cellular, WIFI, RF or any other wireless medium, communicates with the shipment tracking system. The shipping tracking system includes a software application operable to generate instructions (data communications or queries) on a remote server. The data communications or queries are delivered to a tracking system locating device (wireless device, terminal and/or phone) attached and/or associated to the freight, cargo, load, package, pallet, etc. The data communication may be initiated by either side. This allows the tracking system locating device to provide shipment status and location information associated with the shipment to the tracking system in response to queries from the remote tracking system during a short data communication. Status information may include but it is not limited to a shipment identifier, a shipment status, a time stamp, location, geospatial latitude, geospatial longitude. Where the user interacts with the tracking system locating device a digital voice recording such as a voice signature for a custody transfer of the goods may also be collected. The remote tracking system stores the status information including the digital voice recording and voice signature text and converts the voice recording to the voice signature text and provides an electronic shipment status based on the shipment status information.

Features and advantages of the present invention will be apparent from the accompanying drawings and from the detailed description that follows.

#### BRIEF DESCRIPTION OF THE SEVERAL VIEWS OF THE DRAWINGS

For a more complete understanding of the present invention and the advantages thereof, reference is now made to the

4

following description taken in conjunction with the accompanying drawings in which like reference numerals indicate like features and wherein:

FIG. 1 provides a block diagram associated with the operations of a shipping tracking system provided by embodiments of the present invention;

FIG. 2 illustrates that the goods associated with Shipment may be transported via a delivery network using air, sea or land vehicles, such as but not limited to trucks shown, to a destination location in accordance with embodiments of the present invention;

FIG. 3 provides a block diagram of a multi-stage delivery network in accordance with embodiments of the present invention as FIGS. 1 and 2 only illustrate single stage delivery networks;

FIG. 4 provides a block diagrams illustrating the typical components of various wireless devices and/or terminals used with embodiments of the present invention;

FIG. 5 is a block diagram illustrating the relationship of the differing levels of wireless terminal software (i.e. protocol stack, application framework, and applications);

FIG. 6A provides an exemplary view of a detailed tracking page for a specific shipment order number, the page operable to be presented in a browser by the remote tracking system in accordance with embodiments of the present invention;

FIG. 6B provides an exemplary view of a graphic representation of a tracking page for a specific shipment, the page operable to be presented in a browser by the remote tracking system in accordance with embodiments of the present invention;

FIG. 7 provides a logic flow diagram illustrating potential methods of tracking shipments in accordance with embodiments of the present invention;

FIG. 8 provides a logic flow diagram of a method for transmitting wireless terminal location information in accordance with embodiments of the present invention; and

FIG. 9 provides a logic flow diagram illustrating a method of gathering shipment information associated with freight during shipment in accordance with embodiments of the present invention.

#### DETAILED DESCRIPTION OF THE INVENTION

Preferred embodiments of the present invention are illustrated in the FIGS., like numerals being used to refer to like and corresponding parts of the various drawings.

Embodiments of the present invention address a need for a way to track and provide the proof-of-delivery (POD) of the delivery job, independent of the service provider who is commissioned to the deliver the shipment, independent of the mode of transportation (intermodal transportation), and independent of the number of service providers that participate, trucker, pilot, captain, etc . . . The solution is service provider independent and is highly useful for logistics brokers, who do not own transportation, and for load matching services, who commission the delivery jobs to service providers, as well as shipper, for example those that manufacture goods and subcontract the transportation of those goods into the market

Embodiments of the present invention provide a method used in the generation of a voice recording associated with the status or tracking of shipped goods and the acquisition of the Proof of Delivery (POD) when the voice recording is associated with a consignee accepting the goods. The method includes initiating a call between a remote user and a shipment tracking system. The call is then associated with a shipment. A status of the shipment is determined and a time stamp is assigned to the call. A digital voice signature is

5

acquired during the call. The voice signature is stored to the remote tracking system wherein the voice signature is associated with the shipment, shipment status and time stamp. The voice signature is transformed to text, wherein the text is associated with the voice signature. Finally an electronic shipment status based on the voice signature, text associated with the voice signature, the shipment, shipment status and time stamp is provided.

As mentioned previously, a very large percentage of logistic service providers and more particularly, truck drivers do not carry any scanning handheld devices because the cost is prohibitive. Additionally, those applications running on the handheld devices would need to be compatible with the requirements of many diverse tracking systems. However, these individuals do tend to carry a cell phone while performing their daily tasks and keeping in contact with dispatching centers, clients, emergency services, family and friends. Given that most transportation service providers, the individuals performing the POD of the shipment, carry cell phones or have access to other types of phone based communications. Embodiments of the present invention provide a system and method for providing POD of a shipment by allowing the delivery persons to use their cell phones.

As will be appreciated by one skilled in the art, the present invention may be embodied as a system, method or computer program product. Accordingly, the present invention may take the form of an entirely hardware embodiment, an entirely software embodiment (including firmware, resident software, micro-code, etc.) or an embodiment combining software and hardware aspects that may all generally be referred to herein as a "circuit," "module" or "system." Furthermore, the present invention may take the form of a computer program product embodied in any tangible medium of expression having computer-usable program code embodied in the medium.

Any combination of one or more computer usable or computer readable medium(s) may be utilized. The computer-usable or computer-readable medium may be, for example but not limited to, an electronic, magnetic, optical, electro-magnetic, infrared, or semiconductor system, apparatus, device, or digital, wireless, propagation medium. More specific examples (a non-exhaustive list) of the computer-readable medium would include the following: an electrical connection having one or more wires, a portable computer diskette, a hard disk, a random access memory (RAM), a read-only memory (ROM), an erasable programmable read-only memory (EPROM or Flash memory), an optical fiber, a portable compact disc read-only memory (CD-ROM), an optical storage device, a transmission media such as those supporting the Internet or an intranet, a Personal digital assistant (PDA), Cell Phone, GPS device or a magnetic storage device. Note that the computer-usable or computer-readable medium could even be paper or another suitable medium upon which the program is printed, as the program can be electronically captured, via, for instance, optical scanning of the paper or other medium, then compiled, interpreted, or otherwise processed in a suitable manner, if necessary, and then stored in a computer memory. In the context of this document, a computer-usable or computer-readable medium may be any medium that can contain, store, communicate, propagate, or transport the program for use by or in connection with the instruction execution system, apparatus, or device. The computer-usable medium may include a propagated data signal with the computer-usable program code embodied therewith, either in baseband or as part of a carrier wave. The computer usable program code may be transmitted using any appropriate medium, including but not limited to wireless, wireline, optical fiber cable, RF, etc.

6

Computer program code for carrying out operations of the present invention may be written in any combination of one or more programming languages, including an object oriented programming language such as Java, Smalltalk, C++, Visual Basic, C#, Ajax, HTML, PHP, Web Services or the like and conventional procedural programming languages, such as the "C" programming language or similar programming languages. The program code may execute entirely on the user's computer and/or device, partly on the user's computer, as a stand-alone software package, partly on the user's computer and partly on a remote computer or entirely on the remote computer or server. In the latter scenario, the remote computer may be connected to the user's computer through any type of network, including a local area network (LAN) or a wide area network (WAN), or the connection may be made to an external computer (for example, through the Internet using an Internet Service Provider).

The present invention is described below with reference to flowchart illustrations and/or block diagrams of methods, apparatus (systems) and computer program products according to embodiments of the invention. It will be understood that each block of the flowchart illustrations and/or block diagrams, and combinations of blocks in the flowchart illustrations and/or block diagrams, can be implemented by computer program instructions. These computer program instructions may be provided to a processor of a general purpose computer, special purpose computer, or other programmable data processing apparatus to produce a machine, such that the instructions, which execute via the processor of the computer or other programmable data processing apparatus, create means for implementing the functions/acts specified in the flowchart and/or block diagram block or blocks.

These computer program instructions may also be stored in a computer-readable medium that can direct a computer or other programmable data processing apparatus to function in a particular manner, such that the instructions stored in the computer-readable medium produce an article of manufacture including instruction means which implement the function/act specified in the flowchart and/or block diagram block or blocks.

The computer program instructions may also be loaded onto a computer or other programmable data processing apparatus to cause a series of operational steps to be performed on the computer or other programmable apparatus to produce a computer implemented process such that the instructions which execute on the computer or other programmable apparatus provide processes for implementing the functions/acts specified in the flowchart and/or block diagram block or blocks.

The flowchart and block diagrams in the FIGS. illustrate the architecture, functionality, and operation of possible implementations of systems, methods and computer program products according to various embodiments of the present invention. In this regard, each block in the flowchart or block diagrams may represent a module, segment, or portion of code, which comprises one or more executable instructions for implementing the specified logical function(s). It should also be noted that, in some alternative implementations, the functions noted in the block may occur out of the order noted in the FIGS. For example, two blocks shown in succession may, in fact, be executed substantially concurrently, or the blocks may sometimes be executed in the reverse order, depending upon the functionality involved. It will also be noted that each block of the block diagrams and/or flowchart illustration, and combinations of blocks in the block diagrams and/or flowchart illustration, can be implemented by special purpose hardware-based systems that perform the specified

7

functions or acts, or combinations of special purpose hardware and computer instructions.

FIG. 1 provides a block diagram associated with the operations of a shipping tracking system provided by embodiments of the present invention. Shipment tracking system 100 includes a source location 102, shipped goods or shipment 104, a shipping order or Bill of Lading (BOL) 106, a wireless terminal or device 108, a remote user (driver or delivery personnel) 110, a shipping system 112, a cell station 114, cellular infrastructure 116, remote server 120, public switched telephone network (PSTN) 118, internet 122, an electronic status notification 124 (which may be presented as a table and/or visual map), and a locating system such as that provided by a Global Positioning System (GPS) enabled device 108 via satellite 126. A remote tracking system (software application) may be executed on a remote server 120. The remote tracking system may be accompanied by or generate a shipping order or BOL 106 which is supplied to the source location 102 and is associated with shipment 104. The remote tracking system allows user 110 to use a wireless terminal 108 such as a cellular phone, a satellite phone, a WLAN phone or a PSTN phone. A call may be established between wireless terminal 108 and the remote server 120 wherein User 110 may provide shipment status information associated with Shipment 104 to the remote tracking system. This may be in response to a series of prompts from the remote tracking system during the call. The shipment status information may include but should not be limited to a shipment identifier associated with the shipment such as a tracking number, BOL number, account number, load number, etc., a status of the shipment such as shipment pickup, shipment delivery, an intermediate status or an exception status, a time stamp of the call which may be generated automatically by either the wireless terminal or the remote tracking system, a voice signature which may be provided by the user 110 and may identify user 110 as well as provide additional status information. Also a location information of shipment 104 may be provided. This may be provided based on a transponder associated with the shipment or location information provided by the user or automatically generated from information associated with the wireless terminal 108.

For example user 110 may provide location information verbally or via text in the form of city and state or a street address, city and state wherein this information will be voice recognized (if necessary) and translated to a geographic location that may be visually presented on a map such as that of FIG. 6B. Alternatively the wireless terminal may use cell information associated with the servicing cell when the wireless terminal 108 is a cellular phone or should wireless terminal 108 be GPS equipped this GPS information may be provided during the call as a series of tone information by an application executed within the wireless terminal or may be provided as data during the call. Another possibility would be location information associated with an IP address of a servicing WLAN wireless local area network servicing a wireless terminal 108. Another possibility would be location information associated with the cellular tower servicing the mobile cellular device at the time of the tracking event and or call.

The remote tracking system may store the shipment status information as well as transform the voice signature to text when the text is associated with the voice signature and stored with the shipment status information. An electronic shipment status based on the shipment status information may then be automatically generated and sent to various users. This may be sent in the form of an immediate SMS text message, an

8

email message, a wireless electronic data communication, an update to a web-based tracking system, a facsimile transmission, or a voice transmission.

FIG. 2 illustrates that the goods associated with shipment 104 may be transported via a delivery network using air, sea or land vehicles such as trucks 112 to a destination location 130. Here a consignee 132 may be provided with the wireless terminal or device, 108 by the driver or Remote User, 110 in order to provide a voice signature as POD for shipment 104.

FIG. 3 provides a block diagram of a multi-stage delivery network as FIGS. 1 and 2 only provided single stage delivery networks. FIG. 3 allows for a delivery network having one or more legs. Shipment 104 may be received at a starting location 302 and may be transported to destination location 316 using a single-leg delivery system, such as that provided by block 304 which may be rail, truck, ship or air based. A second option provided may be a multi-leg delivery system involving air, land and sea transportation or any combination thereof as the different elements of delivery systems of blocks 306, 308 and 310. Blocks 312 and 314 indicated a two-legged delivery system however it should be noted that the delivery networks using the tracking systems provided by embodiments of the present invention need not be limited to one, two or three legs rather any number of legs may be used and these goods may be handed off from one user or driver to another user or driver until they reach their intended destination.

FIGS. 1 and 2 also illustrate various steps necessary to provide voice POD. These diverse steps include: (1) Generating the shipping order (BOL); (2) acquiring the drivers location and or status voice recording or consignee's voice to provide a voice record of the delivery, constituting a voice POD; (3) storing the voice recording and or POD transaction record in a remote tracking server; (4) attaching the shipment order number, time stamp, event type and other optional information to the voice POD and converting the voice POD into readable and printable text; and (5) providing visibility of each voice POD record through a web page on the internet. Some of these steps are optional, depending on the event type, application version and/or customer's needs.

As illustrated in FIGS. 1 and 2, during the delivery process, user 110 (the driver or delivery person), using his/her cell phone or a regular land line telephone, may call or receive a call from a dedicated and remotely hosted phone number. The driver then selects from a telephone voice menu the type of event the driver is reporting, for example, a delivery. Next, the driver types into the phone the numeric digits that identify the freight or load being delivered if not know already by the application. Then, the driver presents the phone to user 132 (the recipient or consignee), so that she or he can record her/his name to confirm delivery if a delivery event; if a status event driver records a brief status and/or location. Additionally for every event type driver and or consignee can select, in case of incident, an exception type, for example weather related, traffic, load related, etc, and consequently records a brief status of the exception. At this point the application software of the remote tracking server generates a computerized record with the shipment number, the exact time stamp of the event, the client/shipper ID, the load ID, the event type, and the voice recording for the event, as well as an optional exception type and a short digital recording of the details of such exception. For the purposes of a Delivery event, the voice recording of the consignee is a voice signature and/or proof-of-delivery (POD). This voice recording is transformed through a set of conversion processes by the remote tracking server into readable and printable text, that in conjunction with other parameters, such as telephone Caller ID, physical location, GPS location, and/or optional exception type, etc.,

instantly provides immediate visibility and tracking of the where about of the freight and any events associated with the shipment of the freight and the freight's delivery route. Drivers may still send the BOL paperwork to their clients through their regular slow process, but that information is no longer required to provide the POD, to be able to invoice a job, service customer service calls or to provide visibility and tracking information to internal and external customers. Instead, the BOL paperwork can simply provide supporting evidence in case of a dispute. Additionally, the signed physical BOL can be digitally scanned and/or faxed into the tracking servers and by providing the load ID, such digital version of the BOL document is attached next to the POD of such delivered load into the tracking server, such that the signed BOL can instantly be viewed through the tracking web page along the name and voice signature of the consignee.

FIGS. 4 and 5 provide block diagrams illustrating the typical components of various wireless terminals used according to this disclosure. FIG. 4 depicts wireless terminal 400 having a RF unit 404 that supports Bluetooth®, cellular, or like wireless communications. For example, a cellular RF unit supports wireless communications with the cellular network; a satellite RF unit 404 supports satellite based communications. RF unit 404 couple to antennas 402. These antennas 402 may be located internal or external to the case of the wireless terminal 400. Further, in some embodiments, a single RF unit and/or a single antenna may support communications with both the WLAN and the cellular network. Processor 406 may be an Application Specific Integrated Circuit (ASIC) or another type of processor capable of operating the wireless terminal 400 according to this disclosure. Memory 408 includes both static and dynamic components, e.g., DRAM, SRAM, ROM, EEPROM, etc. In some embodiments, the memory 408 may be partially or fully contained upon an ASIC that also includes the processor 406. Module 407 provides location information via GPS, Cell Location or other like means known to those having skill in the art. A user interface 410 includes a display, indicators, a keyboard, a speaker, a microphone, and/or a data interface, and may include other user interface components known to those still in the art. RF interface 404, processor 406, memory 408, and user interface 410 couple via one or more communication buses/links 416. Battery 412 or power port 418 couples to and powers RF interfaces, processor, memory and the user interface. The embodiment of the wireless terminal 400 illustrated in FIG. 4 provides examples of wireless terminal configurations. Many other varied wireless terminal structures may be operated according to the teachings of the present invention.

A single processing device or a plurality of processing devices operably coupled to memory performs the processing duties within the wireless terminal. Such a processing device may be a microprocessor, micro-controller, digital signal processor, microcomputer, central processing unit, field programmable gate array, programmable logic device, state machine, logic circuitry, analog circuitry, digital circuitry, and/or any device that manipulates signals (analog and/or digital) based on operational instructions. The memory may be a single memory device or a plurality of memory devices. Such a memory device may be a read-only memory, random access memory, volatile memory, non-volatile memory, static memory, dynamic memory, flash memory, cache memory, and/or any device that stores digital information. Note that when the processing duties are implemented via a state machine, analog circuitry, digital circuitry, and/or logic circuitry, the memory storing the corresponding operational instructions may be embedded within, or external to, the circuitry comprising the state machine, analog circuitry, digi-

tal circuitry, and/or logic circuitry. The processing duties include the execution of operational instructions corresponding to at least some of the steps and/or functions may be described later.

Wire and wireless terminals require a complex software set as illustrated in FIG. 5. These terminals require a communications protocol stack having interoperability with many network vendors' equipment and able to support rich multimedia applications within the constraints of a resource-limited system.

FIG. 5 illustrates the three-key components of software 500 within a wireless terminal. These include the protocol stack 502, application framework 504 and applications 506. Protocol stack 502 is often considered to be the most complex part, however, the interaction between application framework 504 and applications 506 and is equally important. Protocol stack 502 implements the signaling specification and is implemented on digital signal processors and ARMs such as RISC processor and numerous accelerators and co-processors.

Software 500 allows hardware set 508 to achieve certain operations. Protocol stack 502 may further include DSP layer 510, as well as GPRS layer 512. Protocol stack 502, application framework 510, and applications 512 allow the user to interact with the wireless terminal through presentation layer 514. A wireless terminal present in advance communication protocol stack. Protocol stack 502 may be derived from case logs associated with the software operations of the wireless terminal.

FIG. 6A provides an exemplary view of a detailed tracking page for a specific shipment order number. This may be presented within a browser window and indicates the status of a specific shipment. This Status 600 includes voice and text POD information as well as tracking information associated with the shipment. Block 602 provides text information associated with a captured voice signature which has been saved as File 604. This voice information may include order number information, a delivery name of the consignee and the destination address. As shown, the consignee's name, to whom the delivery was made, appears in a readable and printable format, where the consignee's name is linked to the original voice POD. In this manner, the original voice signature can be heard shortly after being recorded or anytime thereafter. Table 606 contains time stamped location, event and exception information. This may include voice or audible recordings as indicated by icons 608, shipment status, event information, location (address, city, state, zip and country), caller or device ID, and exception type and details. Table 606 also show the tracking steps of such shipment order number in chronological order as those tracking events were acquired through the voice POD call steps.

FIG. 6B provides a map generated on a remote server and presented in a web browser by the remote tracking system. Map 610 and the various pin point locations 612 identify various locations and statuses of shipment 104. Each pin may have event type information, location information, and time and date information which may be presented in call-out 614. The pins may be color coded for pick up, delivery and exception information to highlight areas specific events of interest during the tracking of the shipment.

Using embodiments of the present invention for providing voice POD has the advantages of substantially shortening the time to invoice and collect for the shipper, substantially diminishing calls either by the shipper or by the consignee/recipient into customer service in order to know the status of a load delivery hence reducing operational costs, and com-

pletely eliminating the calls from dispatching departments to delivery drivers to acquire the status of a delivery job.

If the phone used by the delivery person to obtain the recipient's voice recording is GPS enabled, then the exact position of those deliveries with latitude and longitude can be identified, thus allowing for a matching and verification of the actual physical location of the delivery and the requested location for a delivery.

Additionally, embodiments of the present invention may be used to obtain, record, and store the verbal acceptance of any service. Examples include initiating service contracts with a wide variety of service providers, such as phone service providers, food services and any other service that is remotely requested and cannot be signed for.

Furthermore, embodiments of the present invention may be used for international tracking of loads, the exchange of hands between service provider along the supply chain, and even through customs and revision points.

Embodiments of the present invention provide a system and method that greatly simplifies tracking for the logistics and transportation industry by providing the delivery drivers the ability to acquire POD anywhere at any time and allows anyone who is part of the shipping/distribution/delivery/supply chain/service personnel/crew location/ to access pick up, intermediate status, delivery and any other event information.

FIG. 7 provides a logic flow diagram illustrating potential methods of tracking shipments in accordance with embodiments of the present invention. Operation 700 began with Block 702 where a call is initiated between a remote user and a shipping tracking system or vice versa. In Block 704, the call may be associated with a particular shipment. In Block 706, a status associated with the shipment may be determined. The status may be a shipment pickup, shipment delivery, shipment intermediate status, or shipment exception status or any other. In Block 708, a time stamp may be assigned to the call. A voice prompt system in Block 710 may acquire a voice signature during the call. This voice signature may be from a driver indicating his identity as well as the status of the shipment. In the instance where the status of the shipment is delivered, the voice POD may be a consignee accepting delivery of the shipment with or without exception information associated with it. The voice signature may be stored to a remote server of the remote tracking system in Block 712. This voice signature again is associated with the shipment, the shipment status and the time stamp. Furthermore Block 714 allows for the voice signature to be converted to plain text where again this text information is associated with both the voice signature and the shipment. Block 716 provides an electronic shipment status based on the voice signature, text associated with the voice signature, shipment, shipment status, and time stamp. This electronic shipment status may be provided to a requester in one of many formats. These formats may include but are not limited to an SMS text message, an email message, an update to a web-based tracking system wherein a user may access the web-based tracking system to see the status, a facsimile transmission, voice transmission a telephone call, a radio call a Multimedia message and/or a pager message

The location information may be provided during the call as well. This location information may be based on GPS information, cellular information such as the servicing cell tower and/or antenna servicing the mobile terminal, device or cell phone, geographic area, a voice input wherein the user would provide an address, town, city, state, country and/or zip code location information or some subset thereof Then voice

recognition software would translate this into a geographic area and or point in a map such as a specific point associated with the provided location from the voice recording information. This call may be initiated by a dispatcher from the tracking system to a remote user driver when a driver has not checked in or may be initiated from the driver side or remote user side. This information may be stored for tracking purposes and in the event of a delivery as a POD in order to facilitate invoicing and tracking of goods.

FIG. 8 provides a logic flow diagram of a method for transmitting wireless terminal location information in accordance with embodiments of the present invention. Operations 800 begin with Block 802 where a call may be initiated using the wireless terminal between a first user and a remote tracking system. In Block 804 location of the wireless terminal may be determined. This location may be determined using GPS, servicing cell information associated with a cellular network, Internet protocol address information associated with a wireless terminal or a VOIP terminal or voice input information. In Block 806 the location information of the wireless terminal is provided to an application executed within the upper layers of the protocol stack. This application in Block 808 converts the location of the wireless terminal to a series of tones. The location information may be then transmitted as a series of tones to the remote tracking system during the call in Block 810. Additionally a time stamp may be assigned to the call based by the remote tracking system in Block 812. This stamp may include both time information and the location information transmitted in Block 810. The time-stamped location information associated with the call may then be saved to the remote tracking system in Block 814. This information may be associated with a shipment tracked by the remote tracking system. Block 818 generates a map point or pin for visual presentation in either the tables of FIG. 6A or map of FIG. 6B. Furthermore an electronic status notification may be generated based on the call in Block 816.

FIG. 9 provides a logic flow diagram illustrating a method of gathering shipment information associated with freight during shipment in accordance with embodiments of the present invention. Operations 900 commence with Block 902 initiating an automated data communication between a remote tracking system and a tracking system locating device. This tracking system locating device may be located proximate to the freight such as either being attached to or located on a pallet associated with the freight. In Block 904 a query is received at the tracking system locating device. This query may be generated by the remote tracking system or in an automated fashion from the tracking system locating device itself. In Block 906 an application executed on the tracking system locating device is prompted to determine the tracking system locating device's location. Other information may be determined as well, such as but not limited to the time. In response to the query, in Block 908, the remote tracking system receives a data communication from the tracking system locating device that includes shipment information associated with the freight. The shipment information may include status, timestamp, location information, caller I.D. of the tracking system locating device as well as a voice signature if there is an exception event or delivery event or any change of custody event associated with the freight. This information may be stored to a database by the remote tracking system and presented on demand in either a tabular or visual format such as the tables of FIG. 6A or map with event callouts provided by FIG. 6B.

13

In summary, the present invention provides a method used in the acquisition of a voice recording associated with the status or tracking of shipped goods. The method includes initiating a call between a remote user and a shipment tracking system. The call is then associated with a shipment. A status of the shipment is determined and a time stamp is assigned to the call. A digital voice signature is acquired during the call. The voice signature is stored to the remote tracking system wherein the voice signature is associated with the shipment, shipment status and time stamp. The voice signature is transformed to text, wherein the text is associated with the voice signature. Finally an electronic shipment status based on the voice signature, text associated with the voice signature, the shipment, shipment status and time stamp is provided.

As one of average skill in the art will appreciate, the term "substantially" or "approximately", as may be used herein, provides an industry-accepted tolerance to its corresponding term. Such an industry-accepted tolerance ranges from less than one percent to twenty percent and corresponds to, but is not limited to, component values, integrated circuit process variations, temperature variations, rise and fall times, and/or thermal noise. As one of average skill in the art will further appreciate, the term "operably coupled", as may be used herein, includes direct coupling and indirect coupling via another component, element, circuit, or module where, for indirect coupling, the intervening component, element, circuit, or module does not modify the information of a signal but may adjust its current level, voltage level, and/or power level. As one of average skill in the art will also appreciate, inferred coupling (i.e., where one element is coupled to another element by inference) includes direct and indirect coupling between two elements in the same manner as "operably coupled". As one of average skill in the art will further appreciate, the term "compares favorably", as may be used herein, indicates that a comparison between two or more elements, items, signals, etc., provides a desired relationship. For example, when the desired relationship is that signal 1 has a greater magnitude than signal 2, a favorable comparison may be achieved when the magnitude of signal 1 is greater than that of signal 2 or when the magnitude of signal 2 is less than that of signal 1.

The terminology used herein is for the purpose of describing particular embodiments only and is not intended to be limiting of the invention. As used herein, the singular forms "a", "an" and "the" are intended to include the plural forms as well, unless the context clearly indicates otherwise. It will be further understood that the terms "comprises" and/or "comprising," when used in this specification, specify the presence of stated features, integers, steps, operations, elements, and/or components, but do not preclude the presence or addition of one or more other features, integers, steps, operations, elements, components, and/or groups thereof.

The corresponding structures, materials, acts, and equivalents of all means or step plus function elements in the claims below are intended to include any structure, material, or act for performing the function in combination with other claimed elements as specifically claimed. The description of the present invention has been presented for purposes of illustration and description, but is not intended to be exhaustive or limited to the invention in the form disclosed. Many modifications and variations will be apparent to those of ordinary skill in the art without departing from the scope and spirit of the invention. The embodiment was chosen and described in order to best explain the principles of the invention and the practical application, and to enable others of

14

ordinary skill in the art to understand the invention for various embodiments with various modifications as are suited to the particular use contemplated.

The invention claimed is:

1. A method comprising:
  - initiating a call between a remote user and a shipment tracking system;
  - associating the call with a shipment;
  - determining a status of the shipment;
  - assigning a time stamp to the call;
  - prompting the remote user via an automated voice prompt system to input data as voice or tones;
  - extracting the data from the voice or tone inputs, wherein the data is associated with the shipment, shipment status and time stamp;
  - acquiring a voice signature during the call;
  - storing the voice signature to the remote tracking system wherein the voice signature is associated with the shipment, shipment status and time stamp;
  - transforming the voice signature to text, wherein the text is associated with the voice signature; and
  - providing an electronic shipment status based on the voice recording, text associated with the voice signature, the data extracted from the voice or tone inputs, the shipment, shipment status and time stamp.
2. The method of claim 1, wherein the call is initiated on behalf of a consignee accepting delivery of the shipment.
3. The method of claim 1, wherein the status comprises at least one status selected from the group comprising: shipment pickup; shipment delivery; shipment intermediate status; and shipment exception status.
4. The method of claim 1, wherein the electronic shipment status is provided in at least one format selected from the group consisting of:
  - a SMS text message;
  - an email message;
  - an update to a web based tracking system;
  - a facsimile transmission; and
  - a voice transmission.
5. The method of claim 1, wherein location information is:
  - received from the remote user and/or a remote device;
  - associated with the shipment; and
  - included within the electronic shipment status.
6. The method of claim 1, wherein a call is initiated from a dispatching location by the remote tracking system to the remote user.
7. The method of claim 1, further comprising storing the electronic shipment status.
8. The method of claim 1, further comprising:
  - storing within a database, information associated with each shipment event, the information comprising a time stamp, event type, location, zip code, caller ID, exception information, delivery details such as voice recording for POD when the event type is a delivery event, a visual representation of readable text of name of consignee; and visually presenting the information on a map by a location of each shipment event.
9. A shipment tracking system comprising:
  - a network based remote tracking system executed on a remote server, the remote tracking system operable to generate a shipping order associated with the shipment;
  - a delivery network operable to receive, transport and deliver the goods;

15

an automated voice prompt system which:  
 receives a call from a remote user;  
 prompts the remote user to input data as voice, digital data  
 or tones;  
 extracts the data from the voice, digital data or tone inputs;  
 at least one wireless terminal, wherein a call may be estab- 5  
 lished between the at least one wireless terminal and the  
 remote tracking system, wherein a user may provide  
 shipment status information associated with the ship-  
 ment to the remote tracking system in response to 10  
 prompts from the remote tracking system during the call,  
 wherein the shipment status information comprises:  
 a shipment identifier associated with the shipment;  
 a status of the shipment;  
 a time stamp of the call;  
 a caller ID associated with the call;  
 a voice recording;  
 a text transcription, said text having been transformed from  
 said voice recording;  
 a location of the shipment;  
 the remote tracking system operable to: 20  
 store shipment status information;  
 transform the voice signature to text, wherein the text is  
 associated with the voice signature; and  
 provide an electronic shipment status based on the ship- 25  
 ment status information.

10. The shipment tracking system of claim 9, wherein the  
 call is initiated on behalf of a consignee accepting delivery of  
 the shipment.

11. The shipment tracking system of claim 9, wherein the  
 status of the shipment comprises at least one status selected 30  
 from the group comprising:

16

shipment pickup;  
 shipment delivery;  
 shipment intermediate status; and  
 shipment exception status.

12. The shipment tracking system of claim 9, wherein the  
 electronic shipment status is provided in at least one format  
 selected from the group consisting of:  
 a SMS text message;  
 an email message;  
 an update to a web based tracking system;  
 a facsimile transmission; and  
 a voice transmission.

13. The shipment tracking system of claim 9, wherein  
 location information is: 15  
 determined with Global Positioning Satellites (GPS);  
 determined by identifying a servicing cell associated with  
 the wireless terminal;  
 determined by identifying an internet protocol address  
 associated with the wireless terminal; or  
 zip code or detailed location and street address of delivery 20  
 event.

14. The shipment tracking system of claim 9, wherein  
 shipment status information comprises: 25  
 exception information;  
 a voice recording associated with a delivery event;  
 a visual or digital representation of a BOL;  
 a scheduled delivery time; or  
 optional reference number associated with the delivery  
 event.

\* \* \* \* \*

9

# Haulcom



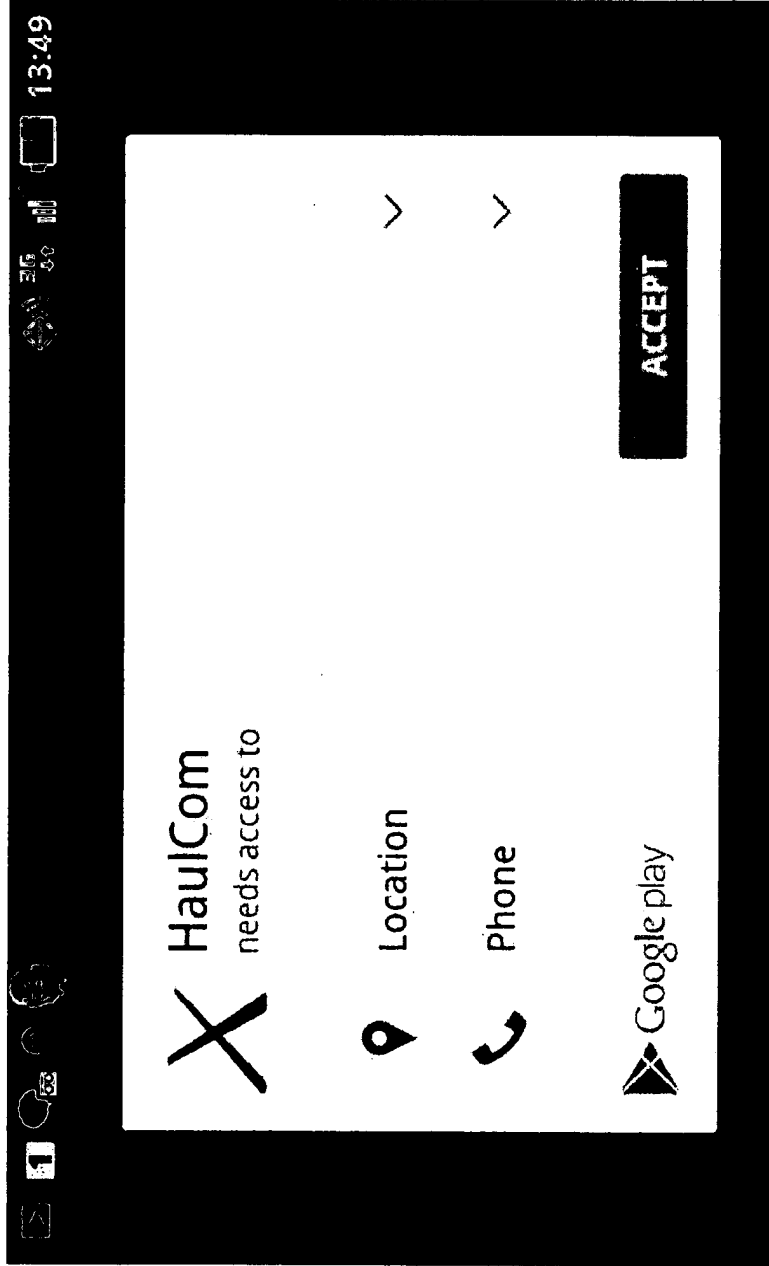

Google Play will remind you that in order to use the Haulcom app, Haulcom needs to access your location and phone. Please press the ACCEPT button.