



US006175608B1

(12) **United States Patent**
Pyles et al.

(10) **Patent No.:** **US 6,175,608 B1**
(45) **Date of Patent:** **Jan. 16, 2001**

(54) **PEDOMETER**

(75) Inventors: **Nathan Pyles**, Lake Mills; **Joel M. Macht**, Reeseville, both of WI (US); **Chen Shui-Jung**, Taipei (TW)

(73) Assignee: **KnowMo LLC**, Lake Mills, WI (US)

(*) Notice: Under 35 U.S.C. 154(b), the term of this patent shall be extended for 0 days.

(21) Appl. No.: **09/181,738**

(22) Filed: **Oct. 28, 1998**

(51) **Int. Cl.**⁷ **G01C 21/00**

(52) **U.S. Cl.** **377/24.2**

(58) **Field of Search** **377/24.2**

(56) **References Cited**

U.S. PATENT DOCUMENTS

- 4,053,755 10/1977 Sherrill .
- 4,144,568 3/1979 Hiller et al. .
- 4,220,996 9/1980 Searcy .
- 4,223,211 9/1980 Allsen et al. .
- 4,334,190 6/1982 Sochaczewski .
- 4,337,529 6/1982 Morokawa .
- 4,371,945 2/1983 Karr et al. .
- 4,387,437 6/1983 Lowrey et al. .
- 4,460,823 7/1984 Ruehleemann .
- 4,466,204 8/1984 Wu .
- 4,510,704 4/1985 Johnson .
- 4,560,861 12/1985 Kato et al. .
- 4,566,461 1/1986 Lubell et al. .
- 4,578,769 3/1986 Frederick .
- 4,651,446 3/1987 Yukawa et al. .
- 4,703,445 10/1987 Dassler .
- 4,741,001 4/1988 Ma .
- 4,763,287 8/1988 Gemaeuser et al. .
- 4,771,394 9/1988 Cavanagh .
- 4,830,021 5/1989 Thornton .
- 4,855,942 8/1989 Bianco .
- 4,962,469 10/1990 Ono et al. .

- 5,033,013 7/1991 Kato et al. .
- 5,065,414 11/1991 Endou et al. .
- 5,117,444 5/1992 Sutton et al. .
- 5,164,967 11/1992 Endo et al. .
- 5,475,725 12/1995 Nakamura .
- 5,476,427 12/1995 Fujima .
- 5,485,402 1/1996 Smith et al. .
- 5,490,816 2/1996 Sakumoto .
- 5,516,334 5/1996 Easton .
- 5,526,290 6/1996 Kanzaki .
- 5,583,776 12/1996 Levi et al. .
- 5,720,200 2/1998 Anderson et al. .
- 5,724,265 3/1998 Hutchings .
- 5,891,042 * 4/1999 Sham et al. 600/483
- 5,899,963 5/1999 Hutchings .
- 5,976,083 11/1999 Richardson et al. .
- 6,018,705 1/2000 Gaudet et al. .

FOREIGN PATENT DOCUMENTS

0 119 009 A1 9/1983 (EP) .

OTHER PUBLICATIONS

PCT/ISA/210—International Search Report received Mar. 20, 2000, 4 pgs.
PCT/IPEA/408, Written Opinion received Aug. 7, 2000, 5 pgs.

* cited by examiner

Primary Examiner—Margaret R. Wambach
(74) *Attorney, Agent, or Firm*—Lathrop & Clark LLP

(57) **ABSTRACT**

The pedometer having improved accuracy by calculating actual stride lengths of a user based on relative stride rates. The pedometer includes a waist or leg mounted stride counter, a transmitter for transmitting data to a wrist-mounted display unit, and a data processor for calculating necessary base units and actual stride rates and lengths. The pedometer can also interact with a heart monitoring device.

33 Claims, 1 Drawing Sheet

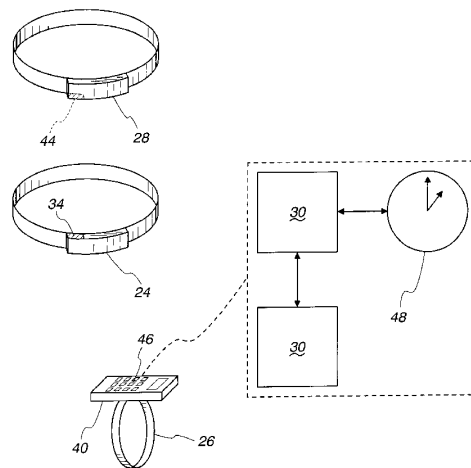

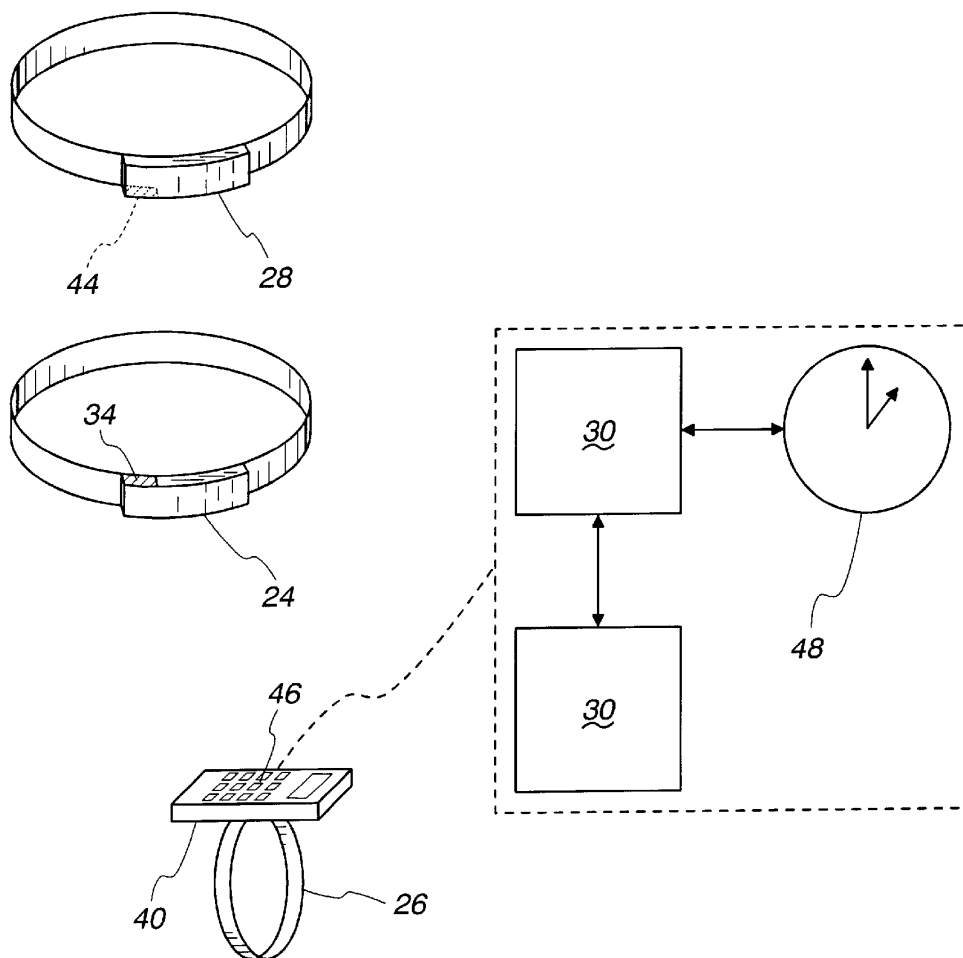

1

PEDOMETER

FIELD AND BACKGROUND OF THE INVENTION

The present invention relates generally to pedometers having a waist mounted stride-counting device and transmitter, and a wrist-mounted receiver and display. The invention also relates to a distance calculation device that calculates a distance walked or run based on an algorithm that converts a base stride length and a base stride rate to an actual stride length for use in calculating the distance traveled.

Pedometers are known which include devices or algorithms for determining the distance a person travels on foot. For example, U.S. Pat. No. 4,371,945 discloses an electronic pedometer that calculates distance by electronically measuring the length of each stride taken by a user. Stride length is measured by ultrasonic waves generated by an ultrasonic module strapped to one leg and an ultrasonic detector worn on the other leg. A program compensates for a variety of measurement errors and the results are displayed on a wrist-mounted display after being transmitted by VHF waves from the leg to the wrist.

U.S. Pat. No. 4,771,394 discloses a computer shoe with a heel-mounted electronic device with an inertia footstrike counter, a timer, a sound generating device, a battery, and a gate array for counting time and footstrikes to calculate distance and running time as a function of stride time. Although recognizing the important relationship of stride length and foot speed, the shoe in this patent requires data from at least 15 test runs or walks and the data must be user-entered in pairs of footstrikes and elapsed time to cover a pre-determined distance. Further, user adjustments of time must be performed to accommodate start and stop times, and the number of counted footstrikes is increased one percent to overcome inherent errors in the inertia step counter. The shoe-mounted device is subject to damage from impact, dirt, and water, and requires a stay-at-home computer with which to interface. There is no means disclosed to transmit data to a wrist-mounted display device or an "on-board" computing device that provides "real time" data to a runner.

U.S. Pat. No. 4,855,942 discloses a pedometer and calorie measuring device that includes a wrist-mounted step counter and a fixed stride length to calculate distance traveled. Wrist-mounted step counters are known to be inaccurate because they assume a step for every arm movement. Even with error correction, such a device will provide less accurate step counts than a leg or waist-mounted counter. Further, fixed stride lengths do not take into account the fact that stride length varies with rate of movement.

U.S. Pat. No. 5,117,444 discloses a pedometer and calibration method with two calibration modes. First, a user travels a predetermined "half-distance" for the device to count and store the number of strides in that distance. Next, the user travels a second distance with the step counter comparing actual steps to the steps in memory and a current trip memory are incremented by a tenth of a "whole unit" distance. There is no correlation between stride length and stride rate which requires the user to re-calibrate the device when walking as opposed to running.

U.S. Pat. No. 5,475,725 discloses a pulse meter with pedometer function to determine pace and pulse rate of a user. The meter uses pulse wave base data compared to actual pulse wave data rates.

U.S. Pat. No. 5,476,427 discloses a pace display device utilizing a base rate for traveling pre-set distances in suc-

2

cessive trails. The device calculates step counts and rates, and compares actual step count rates to display data to a user for comparison of present running rates to previous rates.

Thus, there is a need for a simple, but highly accurate, pedometer that displays distance traveled, pace, speed, heart rate, and other important information on an easily read wrist-mounted device.

SUMMARY OF THE INVENTION

The present invention overcomes problems and shortcomings in the prior art by providing a device that includes a waist, chest, or leg-mounted stride counting device, a transmitter, and a wrist-mounted receiver/display device that provides highly accurate travel distances and other information. The device includes a computer that stores base stride length and rate data from traveling a pre-determined distance and compares that to actual stride rate data to calculate actual distance traveled, speed, and pace. The invention recognizes the interdependency of stride length and stride rate and uses that relationship to provide superior distance-calculating accuracy.

The invention also provides for improved display of relevant data on a wrist-mounted display that receives digital signals from devices worn on other body parts such as legs, waist, and chest. Transmitters that can send coded signals are desirable because they will not interfere with similar devices worn by other users in the vicinity.

The accuracy of the device is enhanced by the use of an algorithm that adjusts a base stride length based on actual stride rates. The algorithm is defined as:

$$\text{Actual Stride Length} = \text{Base Stride Length} + \text{Base Stride Length} * (((\text{Actual Stride Rate} - \text{Base Stride Rate}) / \text{N}) / \text{Base Stride Rate});$$

where N is either an average value or a derived value from a plurality of samples.

The invention also includes a method for calculating an actual stride length including steps of timing a first user run of a predetermined distance; counting the total number of strides in the user first run; dividing the first run distance by the stride count to obtain a base stride length; dividing the stride count by the first run time to obtain a base stride rate; counting strides during a user's second run to obtain an actual stride rate; calculating the actual stride length using the formula:

$$\text{Actual Stride Length} = \text{Base Stride Length} + \text{Base Stride Length} * (((\text{Actual Stride Rate} - \text{Base Stride Rate}) / \text{N}) / \text{Base Stride Rate});$$

wherein N is an average value or a derived value.

The average value method can be refined by comparing Base Stride Rate to Actual Stride Rate to determine a percentage difference; and using N=1 when the Actual Stride Rate \leq Base Stride Rate * 1.02 and using N=3 when Actual Stride Rate $>$ Base Stride Rate * 1.02. A preferred embodiment uses a plurality of sample runs over known distances to derive an accurate N value for each individual.

BRIEF DESCRIPTION OF THE DRAWINGS

FIG. 1 is a schematic diagram of a pedometer in accordance with the present invention.

DETAILED DESCRIPTION OF THE DRAWINGS

As illustrated in FIG. 1, the present invention is directed to an improved pedometer 20 including: a waist, chest, or leg

3

mounted stride counter **24**, and a wrist or waist mounted display unit **26**. An optional chest-mounted heart monitor **28** can be included. All of the device components are mounted in suitable housings. The pedometer **20** includes a data processor **30** that is mounted in the same housing as either the step counter **24** or the display unit **26**.

The step counter **24** is an inertia device that counts the number of steps a user takes. The number of steps is transmitted to a data archive **32** either directly or via a transmitter **34**. The data archive **32** is mounted in the housing with the step counter **24** or the display unit **26**.

The transmitter **34** is mounted in the step counter housing and is preferably an Rf telemetric signal transmitter with a 30 inches to 36 inches transmission range. Alternately, the transmitter is a wireless or wired digital transmitter with a coding function to limit or eliminate interference with other similar devices. The wireless transmission range is set between 30 inches and 36 inches to provide adequate range to transmit signals from a user's waist to wrist, but not so far as to cause interference with other Rf or digital devices in the vicinity.

The transmitter **34** transmits either raw data or calculated distances, pace, etc. to a wrist-mounted display unit receiver **40**. The receiver **40** relays a raw data signal to the data processor **30** or a calculated data signal directly to the display panel **42**, such as an LCD or LED.

Similarly, the heart rate monitor **28** includes a transmitter **44** that transmits heart rate data to the display unit **26**. The heart monitor transmitter **44** can transmit at the same or a different frequency as the stride counter **24**, and to the same or a different receiver in the display unit **26**. The heart rate transmitter **44** is preferably Rf, but can be digital for the reasons stated above. The range of the heart rate transmitter **44** should also be between 30 inches and 36 inches to ensure effective communication with the receiver while limiting outside interference.

The data processor **30** can also include a programmable logic controller, a personal computer, a programmable read-only memory, or other suitable processor. The data processor **30** includes a data archive **32** to store historic data on stride length and pace to be used in an algorithm for calculating actual distances, speed, and rate for real-time conversion of data to useful information for a user.

The data processor **30** can also include closed loop or fuzzy logic programming to continually or periodically replace the base stride rate and length with recently calculated stride rates and lengths so that long term conditioning trends are accommodated in the base stride archive. Incorporating trend capabilities may further enhance accuracy of the distance and pace calculations.

The display unit **26** also includes an operator interface **46** such as a key pad, button, knob, etc. that enables the user to start and stop a clock **48** (or stop watch) and activate various use modes within the pedometer, such as a sampling mode and operation mode.

One option for using the pedometer **20**, requires the user to operate a "sampling mode" and begin walking or running a pre-determined distance such as a mile or 1600 meters, preferably on a running track of a known size. Upon completion of the distance, a stop button on the operator interface **46** is pushed. The data processor **30** is programmed to then divide the distance by the number of strides counted to calculate an average stride length. This value is stored in the data archive **32** as the "Base Stride Length."

Also, the data processor **30** is programmed to divide the number of strides by the time of the run or walk as measured by the clock **48** to arrive at a "Base Stride Rate."

4

The data processor **30** preferably includes programming that queries the user about the distance to be run during the sampling mode. By providing options or enabling the use of any distance during the sampling mode, the pedometer **20** provides maximum flexibility for use by people of various physical conditions, or having access to courses of different known distances. Thus, a user may be queried to input a distance to be used in the sampling mode and then be given a list of options such as 400 meters, 440 yards, 1600 meters, or one mile, or be asked to simply input any distance known to the user that will be traveled during the sampling mode.

The present invention makes full use of the relationship between a faster rate of travel and longer stride lengths. In other words, the faster a user is moving, the longer will be the stride length. Over the course of the run or walk, the user's step rate and, therefore, stride length will change and the user will cover more ground when moving fast and less ground when moving slow.

Clearly, using a fixed average stride length in calculating distance traveled will result in errors using prior pedometers. This is particularly true if a user changes pace, or improves conditioning and speed to the point where the average stride length over a given run increases dramatically. The error compensators in prior devices do not adjust for changes in pace. With the old devices, a user needed to re-calibrate periodically to be close to getting an accurate reading, and could not change pace during a workout without decreasing accuracy.

To make the correction, the user activates a "Use Mode" in which the data processor **30** calculates an Actual Stride Rate based on data from the stride counter **24** and the clock **48**. For example, an Actual Stride Rate can be calculated every five seconds without the user doing more than activating the "Use Mode" button, while all the calculations are performed by the data processor automatically. The percentage change between the Actual Stride Rate and the Base Stride Rate is then computed by the data processor **30** to determine an Actual Stride Length. Again, if the Actual Stride Rate is greater than the Base Stride Rate, the Actual Stride Length is longer than the Base Stride Length. If the Actual Steps Per Second is lower than the Base Steps Per Second, the Actual Stride Length is shorter than the Base Stride Length. The algorithm below provides a means for comparing the Actual and Base Stride rates to arrive at an accurate Actual Stride Length.

First, a comparison between the Actual Stride Rate and the Base Stride Rate is made to determine whether Actual Stride Rate is less than or equal to Base Stride Rate multiplied by 1.02. Stride Length is calculated by:

$$\text{Actual Stride Length} = \text{Base Stride Length} + \frac{\text{Base Stride Length} * (((\text{Actual Stride Rate} - \text{Base Stride Rate}) / \text{Base Stride Rate}) * N)}{1.02}$$

Where: N=1 when Actual Stride Rate is less than or equal to Base Stride Rate multiplied by 1.02, and N=3 when Actual Stride Rate is greater than Base Stride Rate multiplied by 1.02, although other N values in the range of one to three can be used.

The above algorithm is accurate for heel to toe activities such as walking or jogging, but is less accurate for sprinting (toe only).

A third method of calculating actual stride length uses three separate run or walk samples at three different paces. This is the most accurate option. With this method, the N values are unique for each individual. By deriving an N value for each individual, this value more accurately reflects

5

the actual change in stride length with a change in pace. After a proper warmup, the user completes a sample run or walk on the track at a normal pace. This first sample S1, will establish the Base Stride and the Base Steps Per Second.
S1 Sample

$$S1 \text{ Stride} = \text{Base Stride} = \text{Distance} / \text{Number of Steps}$$

$$S1 \text{ Steps Per Second or } S1 \text{ Steps Per Second} = \text{Base Steps Per Second} = \text{Number of Steps Per Second}$$

Following completion of the first run or walk at normal pace, the user runs or walks the same course and the same distance at a faster run or walking pace, but not a sprinting pace. The user should not run on his toes, but maintain the normal heel to toe jogging style. This is the S2 sample. The purpose of the S2 sample is to calculate an N2 value for each individual which reflects the effect an increase in Steps Per Second has on this individual's stride length. Some individual's steps will lengthen more than others as Steps Per Second increases, and by finding the value for N2, this relative increase can be quantified for a more accurate and customized algorithm for each individual.

S2 Sample

To find the N2 value, which will be used by the algorithm when Actual Steps Per Second > Base Steps Per Second

$$N2 = ((S2 \text{ Stride} * S1 \text{ Steps Per Second}) - (S1 \text{ Stride} * S1 \text{ Steps Per Second})) / (S1 \text{ Stride} (S2 \text{ Steps Per Second} - S1 \text{ Steps Per Second}))$$

This value can be calculated since the distance is known, and both a Fast Stride Length (S2 Stride) and a Fast Steps Per Second (S2 Steps Per Second) can be calculated from the second sample.

Following completion of the fast run or walk, the user runs the same course and the same distance at a slower than normal run or walking pace. This pace cannot exceed the first sample pace. This is the S3 sample. The purpose of the S3 sample is to calculate an N3 value for each individual which reflects the effect a decrease in Steps Per Second has on this individual's stride length. Some individual's steps will shorten more than others as Steps Per Second decreases, and by finding the value for N3, this relative decrease can be quantified for a more accurate and customized algorithm for each individual.

S3 Sample

To find the N3 value, which will be used by the algorithm when Actual Steps Per Second < Base Steps Per Second.

$$N3 = ((S3 \text{ Stride} * S1 \text{ Steps Per Second}) - (S1 \text{ Stride} * S1 \text{ Steps Per Second})) / (S1 \text{ Stride} (S2 \text{ Steps Per Second} - S1 \text{ Steps Per Second}))$$

This value can be calculated since the distance is known and both a "Slow" Stride Length (S3 Stride) and a "Slow" Steps Per Second (S3 Steps Per Second) can be calculated from the third sample.

Once these three samples are completed and the information automatically calculated and stored in the data processor 30, then the following formula can be used for the most accurate measurements of speed and distance.

If: Actual Steps Per Second is less than or equal to Base Steps Per Second

Then:

$$\text{Stride Length} = \text{Base Stride} + \text{Base Stride} * (((\text{Actual Steps Per Second} - \text{Base Steps Per Second}) / N) / \text{Base Steps Per Second})$$

And N=N3 (Stored Value)

6

If: Actual Steps Per Second > Base Steps Per Second
Then:

$$\text{Stride Length} = \text{Base Stride} + \text{Base Stride} * (((\text{Actual Steps Per Second} - \text{Base Steps Per Second}) / N) / \text{Base Steps Per Second})$$

And N=N2 (Stored Value)

This third option for calculating stride length, and subsequently distance, speed, and pace, is a far more accurate method than a fixed stride length pedometer. This device and method are also practical, convenient, and has a relatively low manufacturing cost. If an individual's running or walking style is progressing with training and practice (as seen by significantly improved times), then it may be beneficial for them to recalibrate their device by repeating the three samples every 3 to 6 months. If there are no significant improvements in time, then recalibration is not necessary.

It is noted that any single stride length or pace discussed above can in fact be an average of a plurality of stride lengths or rates from test runs to further refine accuracy in the calculations of actual stride data.

Other variations on this device could also incorporate an altimeter which measures changes in elevation. The stride length could then be adjusted (shortened) when elevation is increasing, and lengthened when elevation is decreasing. This adjustment could be done with an average value, as we used in setting option 2, or with a derived value by running or walking over a known distance on a hilly course. This device can use two batteries so that the calibration data is not lost when the batteries are replaced one at a time.

Once the actual stride length is calculated for a given period of time, the value can be multiplied by the number of strides in that period to obtain a total distance for that period to be stored in a data archive file for that particular walk or run and added to other actual stride lengths or distances for other periods in which stride length was calculated. When the run or walk is completed, the user engages the operator interface 46 to indicate that a total distance is to be displayed on the display unit. Preferably, there is continual display of the distance traveled.

As a result of accurately calculating distance traveled, the pedometer 20 also has the capability of calculating speed in miles per hour, for example or pace in minutes per mile, including average speed and pace over the course of that particular walk or run. Further, the pedometer 20 can include a port for coupling to a separate personal computer or computing device to create larger training histories, trends, etc.

Additional features can include stop watches, day, date and time displays, as well as, heart rate displays as discussed above. Also, it will be understood that all distances and time periods used above can be varied in length and units of measure (English, metric, seconds, minutes, hours, etc.).

The foregoing detailed description is provided for clearness of understanding only and no unnecessary limitations therefrom should be read into the following claims.

What is claimed is:

1. A pedometer comprising:

- a step counter mountable on a user first body portion;
- a transmitter in communication with the step counter to generate a signal corresponding to each step and transmit the signal;
- a receiver mountable on a user second body portion to receive the signal transmitted from the transmitter and use the signal to calculate a distance traveled;
- a heart rate monitor; and
- a second transmitter in communication with the heart rate monitor to transmit a signal corresponding to a heart

Explore Litigation Insights

Docket Alarm provides insights to develop a more informed litigation strategy and the peace of mind of knowing you're on top of things.

Real-Time Litigation Alerts



Keep your litigation team up-to-date with **real-time alerts** and advanced team management tools built for the enterprise, all while greatly reducing PACER spend.

Our comprehensive service means we can handle Federal, State, and Administrative courts across the country.

Advanced Docket Research



With over 230 million records, Docket Alarm's cloud-native docket research platform finds what other services can't. Coverage includes Federal, State, plus PTAB, TTAB, ITC and NLRB decisions, all in one place.

Identify arguments that have been successful in the past with full text, pinpoint searching. Link to case law cited within any court document via Fastcase.

Analytics At Your Fingertips



Learn what happened the last time a particular judge, opposing counsel or company faced cases similar to yours.

Advanced out-of-the-box PTAB and TTAB analytics are always at your fingertips.

API

Docket Alarm offers a powerful API (application programming interface) to developers that want to integrate case filings into their apps.

LAW FIRMS

Build custom dashboards for your attorneys and clients with live data direct from the court.

Automate many repetitive legal tasks like conflict checks, document management, and marketing.

FINANCIAL INSTITUTIONS

Litigation and bankruptcy checks for companies and debtors.

E-DISCOVERY AND LEGAL VENDORS

Sync your system to PACER to automate legal marketing.