



United States Patent [19]

Shimizu et al.

[11] Patent Number: **5,998,925**

[45] Date of Patent: **Dec. 7, 1999**

[54] **LIGHT EMITTING DEVICE HAVING A NITRIDE COMPOUND SEMICONDUCTOR AND A PHOSPHOR CONTAINING A GARNET FLUORESCENT MATERIAL**

- 55-4898 1/1980 Japan .
- 62-20237 1/1987 Japan .
- 1-179471 7/1989 Japan .
- 5-152609 6/1993 Japan .
- 7-099345 4/1995 Japan .
- 7-176794 7/1995 Japan .
- 8-007614 1/1996 Japan .
- 9-027642 1/1997 Japan .

[75] Inventors: **Yoshinori Shimizu**, Naka-gun; **Kensho Sakano**, Anan; **Yasunobu Noguchi**, Naka-gun; **Toshio Moriguchi**, Anan, all of Japan

OTHER PUBLICATIONS

[73] Assignee: **Nichia Kagaku Kogyo Kabushiki Kaisha**, Tokushima, Japan

“A New Phosphor for Frying-Spot Cathode-Ray Tubes for Color Television: Yellow-Emitting $Y_3Al_5O_{12}-Ce^{3+}$ ”, G. Glasse et al., Applied Physics Letters, vol. 11, No. 2, pp. 53-54 (1967).

[21] Appl. No.: **08/902,725**

“Improved color rendition in high pressure mercury vapor lamps”, Mary V. Hoffman, Journal of IES, pp. 89-91 (1977).
S. Nakamura, SPIE, 3002:26-35 (1997).

[22] Filed: **Jul. 29, 1997**

[30] Foreign Application Priority Data

Jul. 29, 1996	[JP]	Japan	8-198585
Sep. 17, 1996	[JP]	Japan	8-244339
Sep. 18, 1996	[JP]	Japan	8-245381
Dec. 27, 1996	[JP]	Japan	8-359004
Mar. 31, 1997	[JP]	Japan	9-081010

Primary Examiner—Vip Patel
Assistant Examiner—Michael J. Smith
Attorney, Agent, or Firm—Birch, Stewart, Kolasch & Birch, LLP

[51] **Int. Cl.**⁶ **H01J 1/62**; H01J 63/04

[57] ABSTRACT

[52] **U.S. Cl.** **313/503**; 313/498; 313/501; 313/502; 257/103

The white light emitting diode comprising a light emitting component using a semiconductor as a light emitting layer and a phosphor which absorbs a part of light emitted by the light emitting component and emits light of wavelength different from that of the absorbed light, wherein the light emitting layer of the light emitting component is a nitride compound semiconductor and the phosphor contains garnet fluorescent material activated with cerium which contains at least one element selected from the group consisting of Y, Lu, Sc, La, Gd and Sm, and at least one element selected from the group consisting of Al, Ga and In and, and is subject to less deterioration of emission characteristic even when used with high luminance for a long period of time.

[58] **Field of Search** 313/498, 503, 313/501, 502; 257/103

[56] References Cited

U.S. PATENT DOCUMENTS

3,699,478	10/1972	Pinnow et al.	332/7.51
4,298,820	11/1981	Bongers et al.	.
4,727,283	2/1988	Van Kemenade et al.	.
5,798,537	8/1998	Nitta	257/103

FOREIGN PATENT DOCUMENTS

50-43913	4/1975	Japan	.
----------	--------	-------	---

23 Claims, 19 Drawing Sheets

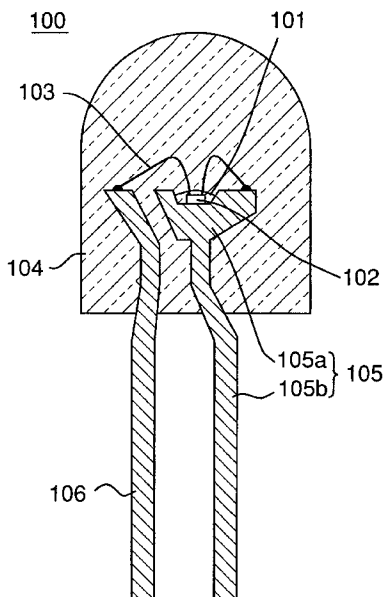

Fig. 1

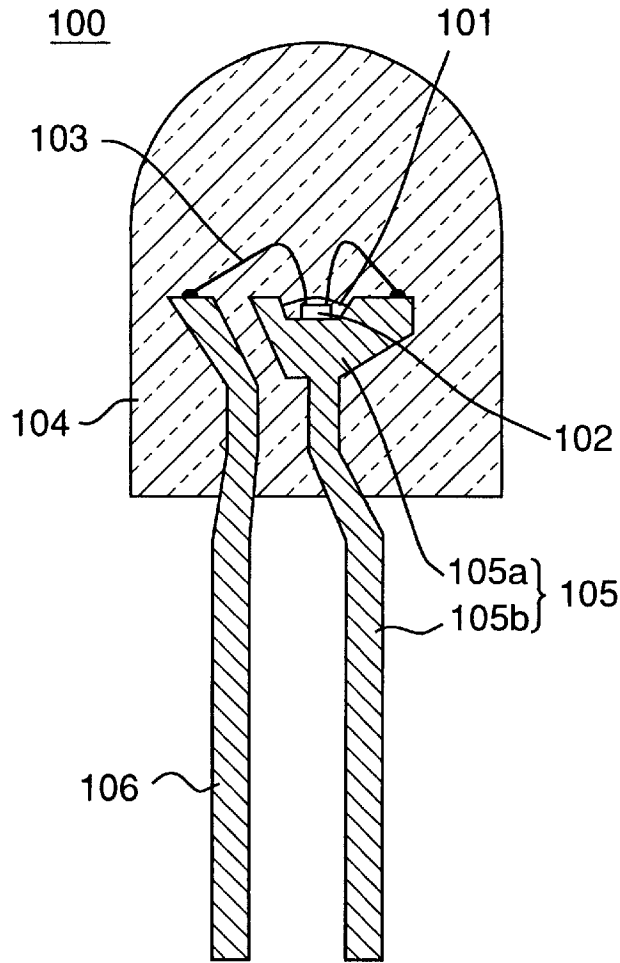

Fig. 2

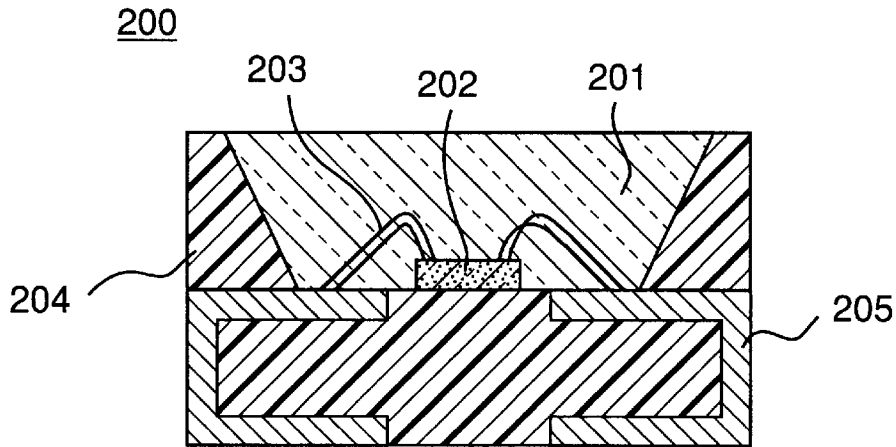

Fig.3A

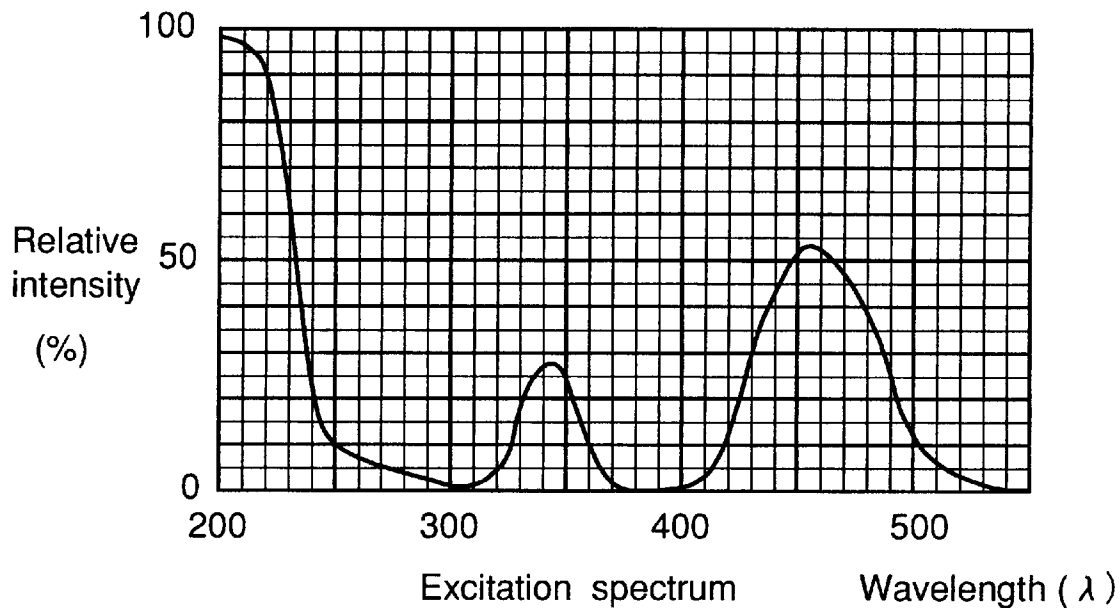

Fig.3B

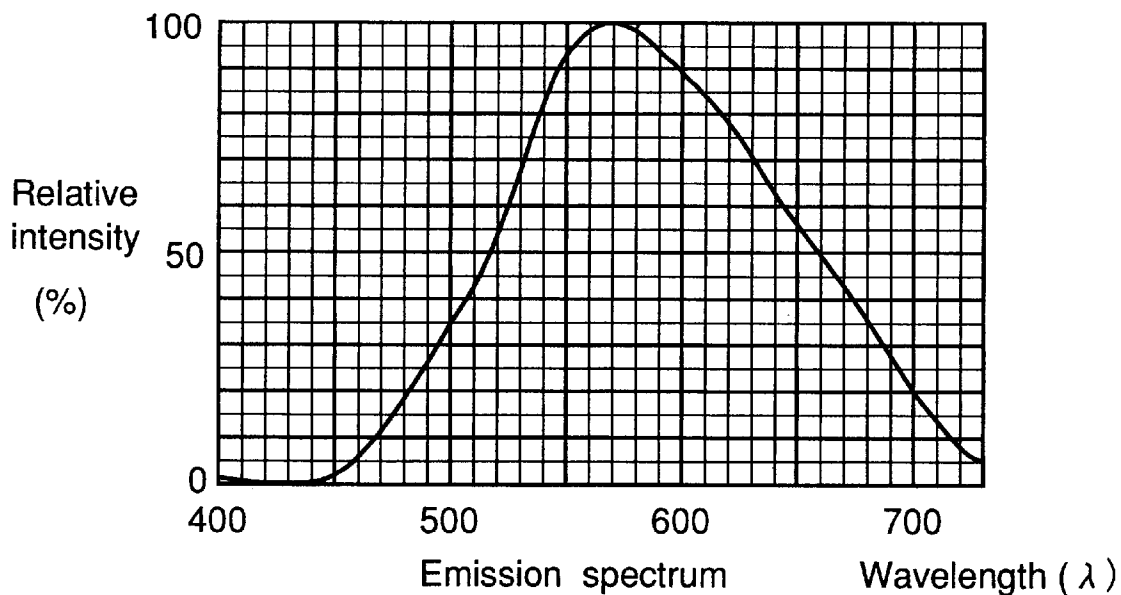

Fig. 4

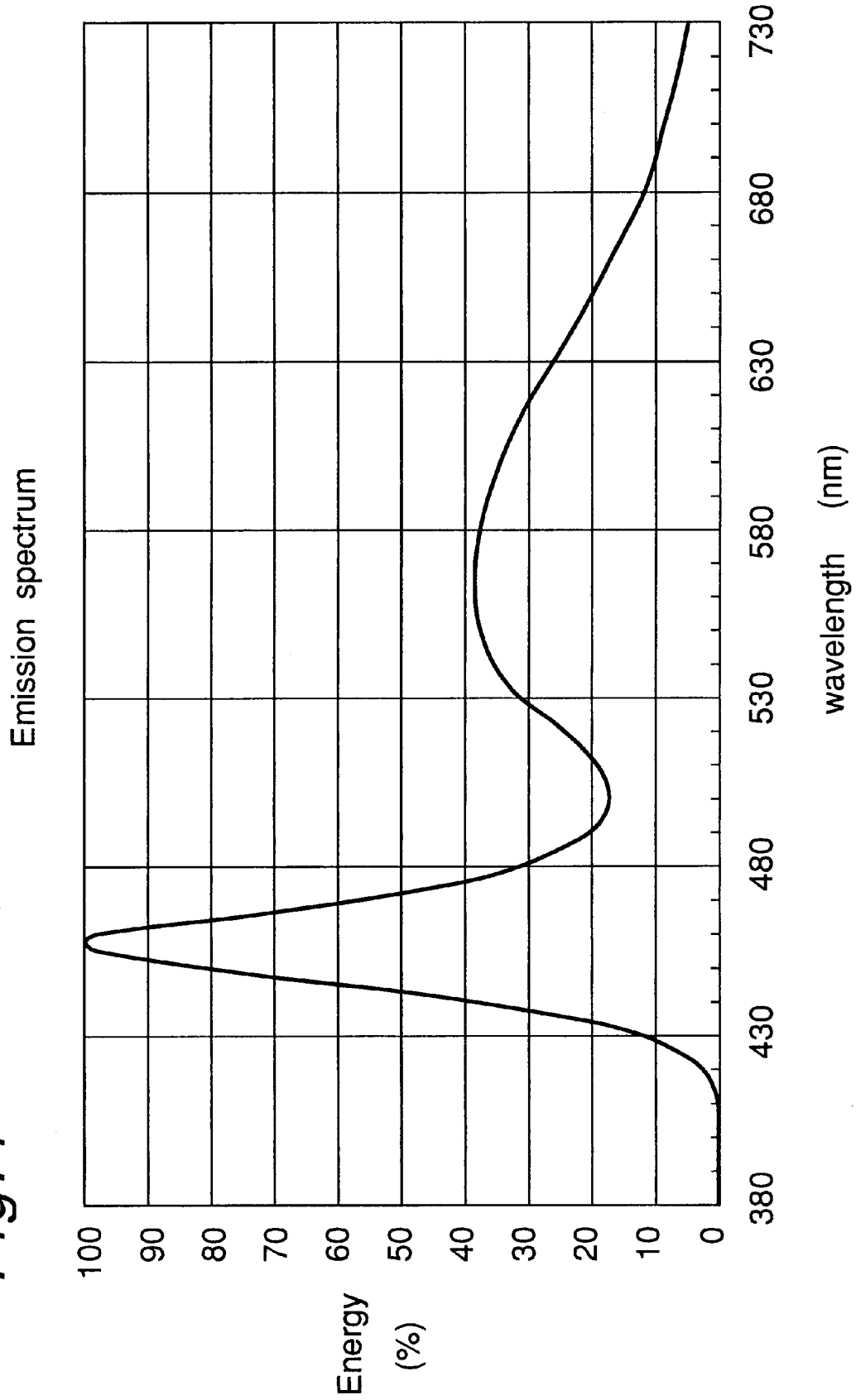

Fig.5A

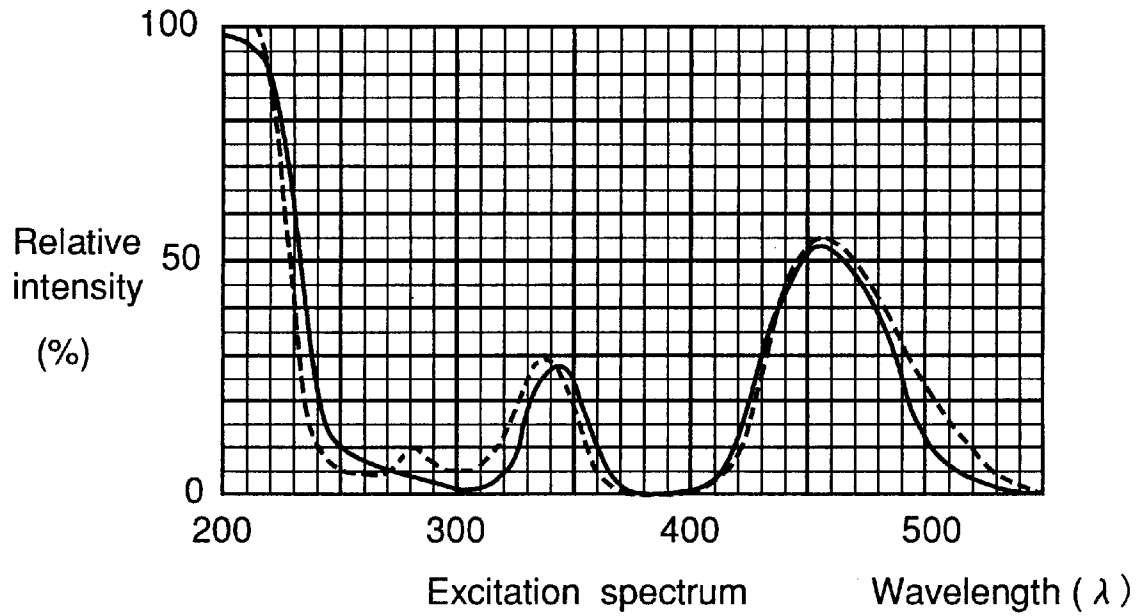
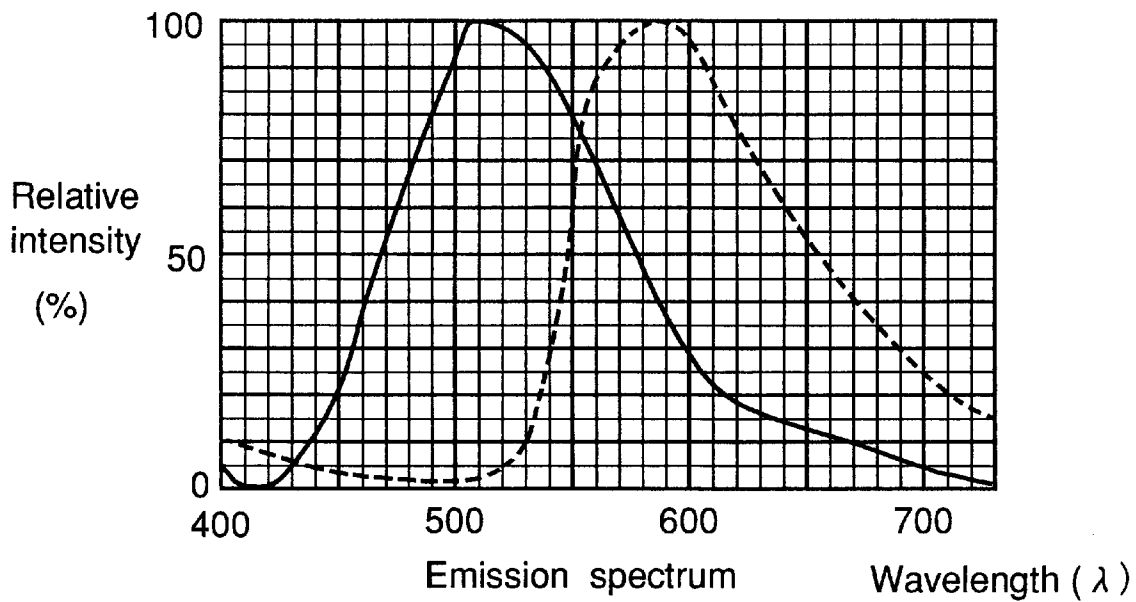

Fig.5B



Explore Litigation Insights

Docket Alarm provides insights to develop a more informed litigation strategy and the peace of mind of knowing you're on top of things.

Real-Time Litigation Alerts



Keep your litigation team up-to-date with **real-time alerts** and advanced team management tools built for the enterprise, all while greatly reducing PACER spend.

Our comprehensive service means we can handle Federal, State, and Administrative courts across the country.

Advanced Docket Research



With over 230 million records, Docket Alarm's cloud-native docket research platform finds what other services can't. Coverage includes Federal, State, plus PTAB, TTAB, ITC and NLRB decisions, all in one place.

Identify arguments that have been successful in the past with full text, pinpoint searching. Link to case law cited within any court document via Fastcase.

Analytics At Your Fingertips



Learn what happened the last time a particular judge, opposing counsel or company faced cases similar to yours.

Advanced out-of-the-box PTAB and TTAB analytics are always at your fingertips.

API

Docket Alarm offers a powerful API (application programming interface) to developers that want to integrate case filings into their apps.

LAW FIRMS

Build custom dashboards for your attorneys and clients with live data direct from the court.

Automate many repetitive legal tasks like conflict checks, document management, and marketing.

FINANCIAL INSTITUTIONS

Litigation and bankruptcy checks for companies and debtors.

E-DISCOVERY AND LEGAL VENDORS

Sync your system to PACER to automate legal marketing.