

[54] DRIVING CIRCUITS FOR LIGHT EMITTING DIODES

3,603,833	9/1971	Logan	317/235 X
3,388,255	6/1968	May	178/7.3 D
3,511,925	5/1970	Lee et al.	178/7.3 D X
3,595,991	7/1971	Diller	178/5.4 EL
3,611,069	10/1971	Galginaihs	317/235

[75] Inventors: George R. Kaelin, Woodland Hills; James A. Pelligrino, Thousand Oaks, both of Calif.

Primary Examiner—Robert K. Schaefer
Assistant Examiner—William J. Smith
Attorney—Robert M. Angus, Alan C. Rose and Alfred B. Levine

[73] Assignee: Litton Systems, Inc., Beverly Hills, Calif.

[22] Filed: Sept. 27, 1971

[21] Appl. No.: 184,076

[52] U.S. Cl. 307/40, 178/7.3 D, 315/169 TV, 340/166 EL, 340/324 R

[51] Int. Cl. H05b 33/00

[58] Field of Search 307/40; 315/169 TV; 340/324 R, 166 EL, 334, 343; 178/5.4 EL, 7.3 D; 317/235

[57] ABSTRACT

LEDs are arranged in a matrix and driven by a pair of registers. A column register sequentially enables the columns of LEDs and a row register selectively operates the LEDs of each column in accordance with a predetermined binary code. A color control and a brightness control circuit may be included in connection with the row register to selectively control driving currents to the LEDs to control color hue, and to selectively control the duration of "on" time to control apparent brightness.

[56] References Cited

UNITED STATES PATENTS

3,021,387	2/1962	Rajchman	178/5.4 EL X
3,517,258	6/1970	Lynch	315/169 TV

17 Claims, 5 Drawing Figures

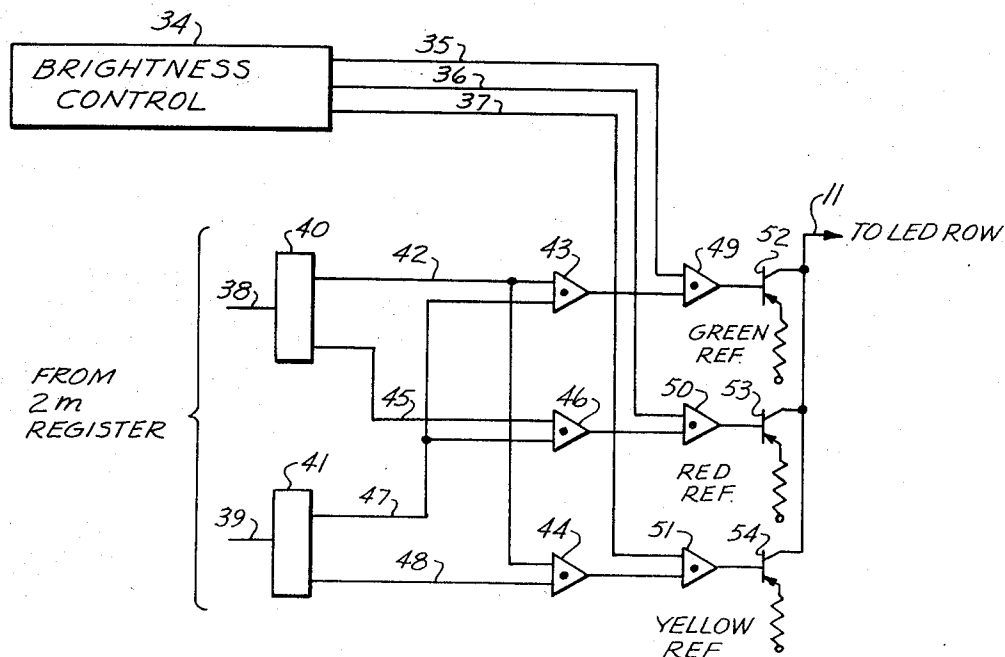

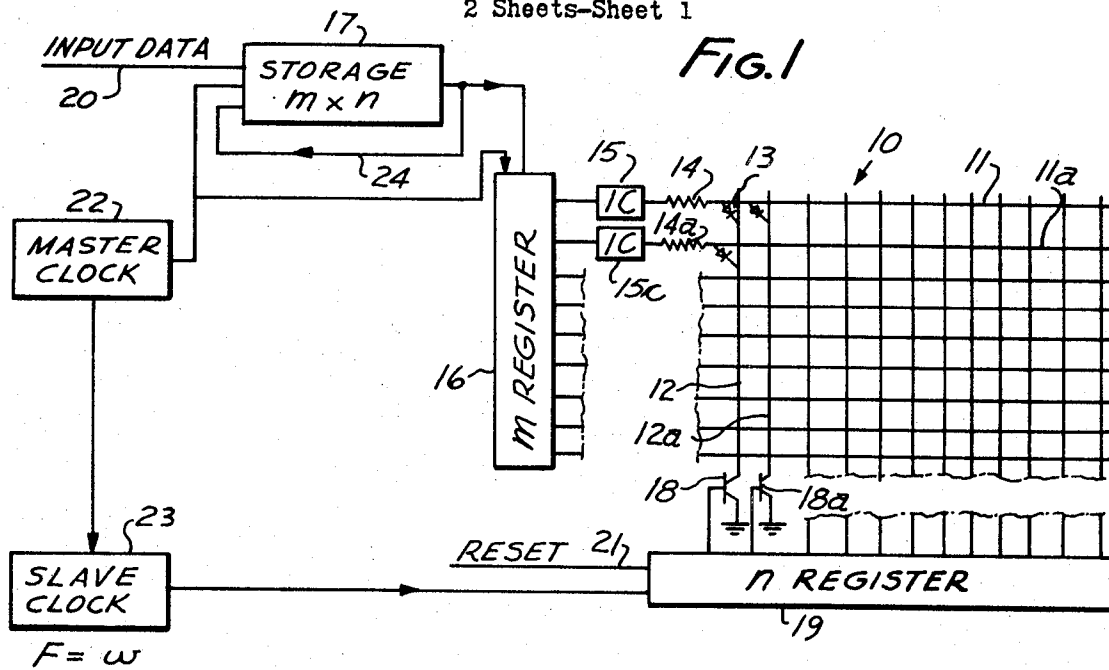
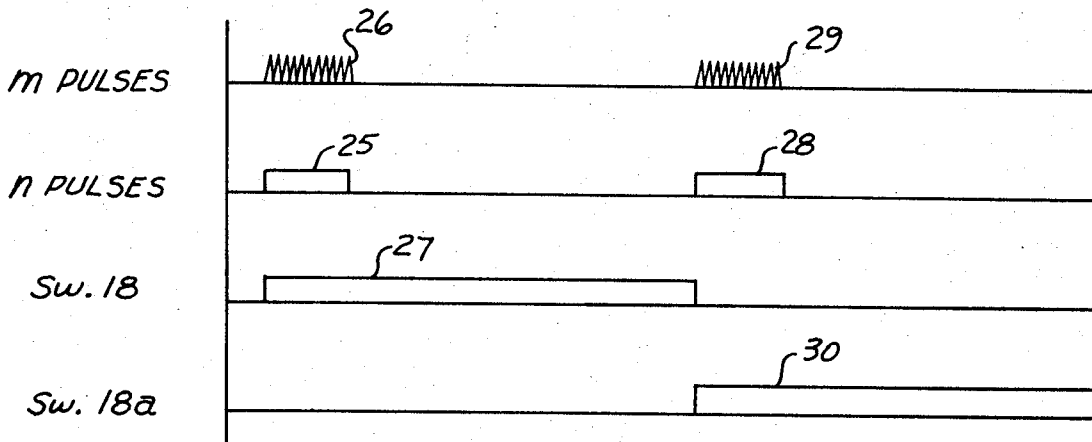
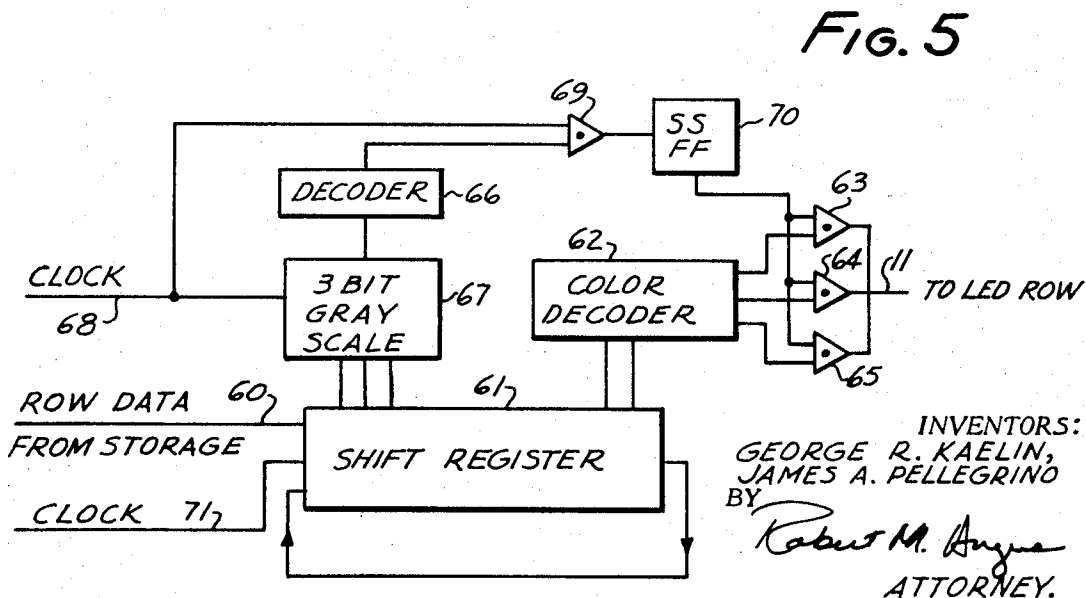
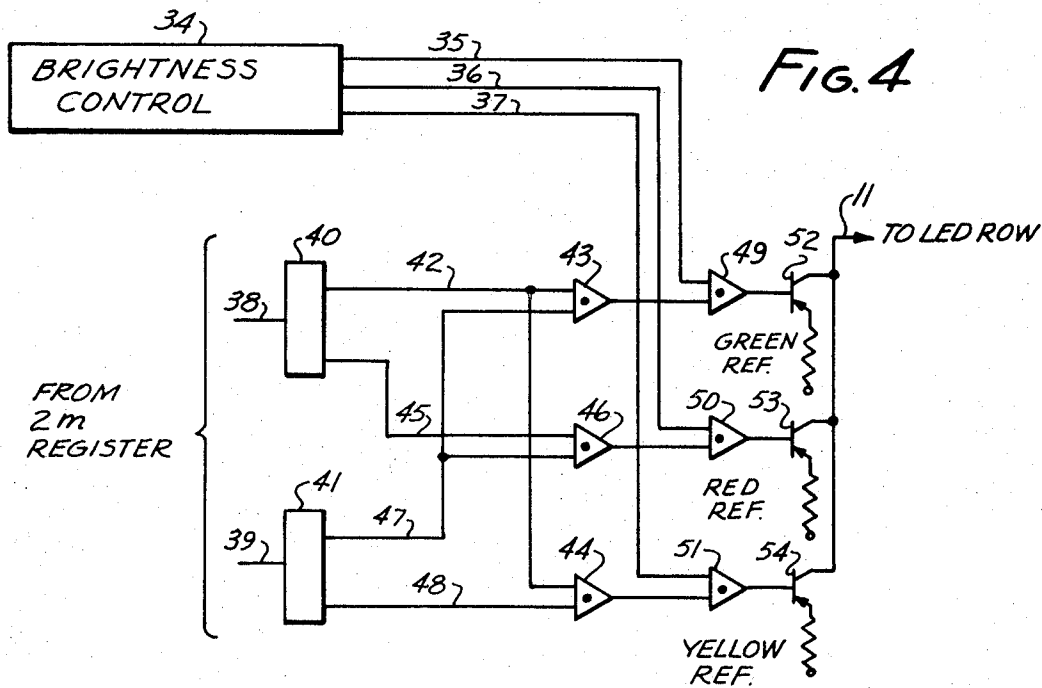
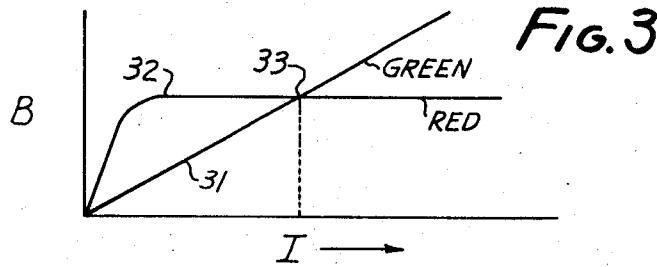

FIG. 2



INVENTORS:
GEORGE R. KAELIN,
JAMES A. PELLEGRINO
BY
Robert M. Hayes
ATTORNEY.



INVENTORS:
GEORGE R. KAELIN,
JAMES A. PELLEGRINO
BY
Robert M. Angus
ATTORNEY.

DRIVING CIRCUITS FOR LIGHT EMITTING DIODES

This invention relates to driving circuits for light emitting diodes, and particularly to circuits for driving light emitting diodes to achieve color display.

Light emitting diodes (LEDs) are useful for alpha-numeric display purposes. LED matrices, when properly driven, can provide alpha-numeric read out of information from a computer. However, in prior LED matrices, the individual diodes were separately operated, so that driving circuits required for operating prior LED displays required numerous connections to the display. The number of connections to prior LED display matrices rendered such matrices cumbersome in use and often expensive to manufacture.

It is an object of the present invention to provide driving circuits for LED display matrices whereby the LEDs may be selectively operated.

It is another object of the present invention to provide a LED driving and memory circuit which may be integrated with a LED matrix to form LED display apparatus requiring fewer interconnections than heretofore achieved.

Certain LEDs exhibit different colors when subjected to driving currents of various amplitudes. Accordingly, it is yet another object of the present invention to provide a driving circuit for a LED matrix for selectively varying the driving currents to the individual LEDs of the matrix to achieve a selectable color display.

Another object of the present invention is to provide intensity control apparatus in multicolor LED display apparatus.

Another object of the present invention is to provide a LED driving circuit for selectively varying the pulse widths of driving current pulses to achieve selective intensity control of the LEDs.

In accordance with the present invention, a plurality of LEDs are disposed in a two-dimensional matrix. The LEDs are arranged in rows and columns. A first shift register is provided for driving the LEDs along the rows and a second shift register is provided for driving the LEDs along the columns. Information is stored in the shift registers to effectuate selective driving of selected ones of the LEDs.

In accordance with one feature of the present invention, the driving circuit includes means for selectively applying driving currents of various amplitudes to the LEDs so that the LEDs display selected colors.

In accordance with another feature of the present invention, means is provided for varying the pulse widths of the driving current pulses to selectively vary the intensity of the display.

The above and other features of this invention will be more fully understood from the following detailed description and the accompanying drawings, in which:

FIG. 1 is a schematic block diagram of a LED display matrix having a driving circuit in accordance with the presently preferred embodiment of the present invention;

FIG. 2 is a diagrammatic representation of waveforms associated with the driving circuit illustrated in FIG. 1;

FIG. 3 is a diagram illustrating the color display characteristics of a light emitting diode;

FIG. 4 is a schematic block diagram of a logic circuit for color control of light emitting diodes in accordance

FIG. 5 is a block logic diagram of a color driving circuit for controlling the intensity and the color of display of light emitting diodes in accordance with another embodiment of the invention.

Referring to FIG. 1 there is illustrated a matrix 10 having m number of leads 11, 11a, etc. arranged in rows and n number of leads 12, 12a, etc. arranged in columns. Leads 11 and 12 are electrically isolated, and are interconnected by a matrix of $m \times n$ number of light emitting diodes 13. For example, the anode of each diode 13 may be connected to a respective lead 11 while the cathode of the diode may be connected to a respective lead 12. Leads 11, 11a, etc. are connected through resistors 14, 14a, etc. and integrated circuits 15, 15a, etc. to individual outputs of m register 16. The input for register 16 is connected to the output of shift register 17. Leads 12, 12a, etc. are connected through transistors 18, 18a, etc. to ground, the base of each transistor 18 being connected to a separate output of n register 19.

Register 19 is a shift register capable of sequencing enable signals to the various outputs of the register. Shift register 19 has a first input 21 for resetting the register and to condition operation of the first transistor 18. A second input is connected to slave clock 23 to sequence an enable signal to the outputs of register 19 to sequentially operate transistors 18, 18a, etc. Register 17 has an input 20 for supplying data to register 17. The input data may be supplied by means (not shown) which develops the input signals in accordance with data to be displayed. The input data to register 17 includes at least one bit for each LED device in matrix 10. As will be more fully understood hereinafter, the input data may include more than one bit per LED device to achieve color and intensity control.

Master clock 22 is connected to one input of storage register 17 and shift register 16, and is connected to an input of slave clock 23. The output of clock 23 is connected to an input of shift register 19. As illustrated in FIG. 1, storage register 17 includes a feed-back path 24 connecting the output of the storage register to its input.

With reference to FIG. 2, the operation of the driving circuit illustrated in FIG. 1 may be explained. Light emitting diodes 13 are connected between each lead 12 and each lead 11 so that connection is made from the $m \times n$ register 16 through the light emitting diodes 13 and transistors 18 to ground, input data is supplied to storage register 17. The input data to register 17 comprises at least $m \times n$ number of bits of information, where m is equal to the capacity of register 16 and n is equal to the capacity of register 19. As will be more fully understood hereinafter, the input data may include some multiple of $m \times n$ bits for color and intensity control. With an m by n matrix 10, the input data to storage register 17 corresponds in length to some multiple of the number of diodes in matrix 10.

Master clock 22 is operated at a frequency equal to $x \times m \times n \times \omega$ where ω is the display cycle refresh frequency of the display, and where x is the number of bits associated with the color and intensity control circuits, if any. Master clock 22 conditions storage register 17 to store $x \times m \times n$ bits of input data, and clocks register 16 to accept $x \times m$ bits from register 17 during each cycle ω . Master clock 22 also drives slave clock 23 to supply n pulses to register 19 to step the output of register 19. The bi-

ter 16 operates through integrated circuit 15 to control the current on each of leads 11. The presence of the n pulse to the input of n register 19 conditions the first transistor 18 to conduct. Hence, current flows through integrated circuits 15, through the light emitting diodes, and transistor 18 in accordance with the binary value of the signals stored in register 16. For example, if eight rows 11 are connected to register 16, m equals 8, and the x m code will consist of x 8 bits. If no color or intensity circuits are associated with integrated circuits 15 (so $x=1$), each "1" bit from register 16 will supply sufficient current to condition the diodes connected to the respective row leads to conduct, whereas those diodes receiving a "0" bit will not be conditioned to conduction. Energization of a selected transistor 18 for each column will complete the conduction path for the LEDs so that those LEDs associated with the 1's from register 16 and associated with the particular column 12 will be energized.

Assuming, for example, that the display is to be in single color and single intensity ($x=1$) during the first n pulse 25, m pulses 26 are stored into register 16. Pulse 25 also conditions register 19 to provide an output to transistor switch 18 to complete a path for all diodes in the first column. The period of conduction for transistor 18 is shown at 27 in FIG. 2. The LEDs remain on during the remainder of pulse 27, at which time clock 22 conditions a new set of m pulses 29 to be stored in register 16. At the same time, clock 22 drives clock 23 to condition shift register 29 to its second output to transistor switch 18a. Transistor 18a conducts for the period illustrated at 30 in FIG. 2.

If during the first n pulse, the m pulse pattern is 11010110 and the integrated circuits are condition to respond to only the 1's of the code, it is evident that the first, second, fourth, sixth and seventh LEDs of the first column will be energized. If during the second n pulse, the m pulse pattern is 00111010, it is evident that the third, fourth, fifth and seventh LEDs of the second column will be energized. The pattern continues through the entire cycle of n register 19. By establishing the cycle frequency ω of n register 19 sufficiently high, the selected LEDs of the matrix will appear, to the human eye, to be conducting at the same time. The m n pulses are recycled through register 17 through loop 24 so that the display will continue for any desirable period of time.

One feature of the present invention resides in the utilization of the color emitting capabilities of certain light emitting diodes. For example, gallium phosphide light emitting diodes available from Bowmar Canada, Ltd., when subjected to a low current emit a predominantly red light. However, when subjected to a relatively high current, such diodes emit a predominantly green light. The brightness of the red and green hues is illustrated in FIG. 3 as a function of current. At low currents, the red hue, illustrated by waveform 32 is predominate over the green hue, illustrated by waveform 31, whereas at high current the green hue predominates. At cross-over point 33, the hues are about equal and will blend to appear as yellow.

FIGS. 4 and 5 relate to driving circuits to take advantage of the color phenomenon for selective color display from LED matrices. The circuits illustrated in FIGS. 4 and 5 may be used for integrated circuits 15 in FIG. 1. In FIG. 4, brightness control circuit 34 has out-

hereinafter, brightness control 34 provides pulses of different pulse widths on the output leads 35, 36 and 37. Input leads 38 and 39 are connected to a shift register having a length equal to $2m$, since $x=2$ to provide for conditions for each LED, three colors and off. For example, the shift register to which leads 38 and 39 are connected is similar to register 16 illustrated in FIG. 1 but so arranged that two bits of information will operate on the circuit illustrated in FIG. 4. Lead 38 provides an input to bistable multivibrator 40, and lead 39 provides an input to multivibrator 41. Multivibrators 40 and 41 each have two outputs, output 42 of multivibrator 40 being connected to an input of AND gates 43 and 44, output 45 of multivibrator 40 being connected to one input of AND gate 46, output 47 of multivibrator 41 being connected to inputs of AND gates 43 and 46, and output 48 of multivibrator 41 being connected to the second input of AND gate 44. AND gate 49 has inputs connected to the output lead 35 from brightness control circuit 34 and to the output from AND gate 43, AND gate 50 has inputs connected to the output 36 of brightness control circuit 34 and to the output of AND gate 46, and AND gate 51 has inputs connected to output lead 37 from brightness control circuit 34 and to the output from AND gate 44. Each of AND gates 49, 50 and 51 are connected to the base of respective transistors 52, 53 and 54. The emitters of transistors 52, 53 and 54 are connected to respective sources (not shown) of constant voltage through resistors, and the collectors of transistors 52, 53 and 54 are connected together to lead 11 of the particular LED row. The driving currents established by the voltage sources and series resistors are different for each transistor 52, 53 and 54. For example, the source connected to the emitter of transistor 52 may produce a relatively high current for green displays, the source connected to emitter of transistor 53 may produce a relatively low current for red displays, and the source connected to the emitter of transistor 54 may produce an intermediate current for yellow displays.

The brightness of a particular LED is determined by the current applied to that diode, which also affects the color hue. However, the "apparent" brightness of such diodes, as perceived by the human eye, is determined by the length of time that the diode is emitting light, as well as actual brightness. Hence, if it is desirable to provide an apparent bright display of red colors, brightness control circuit 34 provides pulses of longer duration on output lead 36 than the pulses on the leads 35 and 37. On the other hand, if it is desired that all colors have substantially the same apparent brightness, the length of pulses applied to each lead 35-37 is inversely proportioned to the pulse amplitude so that the average current to each lead is substantially the same. However, the pulse lengths may be adjusted somewhat to compensate for the differing efficiency of the human eye for different colors.

In operation of the color driving circuit illustrated in FIG. 4, the input signals representative of 1's and 0's are applied to input leads 38 and 39. Multivibrators 40 and 41 provide output signals at one or the other of their outputs depending on the binary value of the input signals. For example, if the input signal to lead 38 is a "1," multivibrator 40 will provide an output at lead 42, where as if the input lead 38 is a "0," multivibrator 40 will provide an output at lead 45. Likewise, multivi-

Explore Litigation Insights

Docket Alarm provides insights to develop a more informed litigation strategy and the peace of mind of knowing you're on top of things.

Real-Time Litigation Alerts



Keep your litigation team up-to-date with **real-time alerts** and advanced team management tools built for the enterprise, all while greatly reducing PACER spend.

Our comprehensive service means we can handle Federal, State, and Administrative courts across the country.

Advanced Docket Research



With over 230 million records, Docket Alarm's cloud-native docket research platform finds what other services can't. Coverage includes Federal, State, plus PTAB, TTAB, ITC and NLRB decisions, all in one place.

Identify arguments that have been successful in the past with full text, pinpoint searching. Link to case law cited within any court document via Fastcase.

Analytics At Your Fingertips



Learn what happened the last time a particular judge, opposing counsel or company faced cases similar to yours.

Advanced out-of-the-box PTAB and TTAB analytics are always at your fingertips.

API

Docket Alarm offers a powerful API (application programming interface) to developers that want to integrate case filings into their apps.

LAW FIRMS

Build custom dashboards for your attorneys and clients with live data direct from the court.

Automate many repetitive legal tasks like conflict checks, document management, and marketing.

FINANCIAL INSTITUTIONS

Litigation and bankruptcy checks for companies and debtors.

E-DISCOVERY AND LEGAL VENDORS

Sync your system to PACER to automate legal marketing.