

UNITED STATES PATENT AND TRADEMARK OFFICE
BEFORE THE PATENT TRIAL AND APPEAL BOARD

HP INC.,
Petitioner,

v.

JAMES B. GOODMAN,
Patent Owner,

Case IPR2017-01994
Patent No. 6,243,315

Before BRIAN J. McNAMARA, PATRICK M. BOUCHER, and
KIMBERLY McGRAW, *Administrative Patent Judges.*

PATENT OWNER'S RESPONSE TO THE DECISION ON THE PETITION

By James B. Goodman
Patent Owner

I. RELATED CASES

A final decision in this proceeding could affect the following cases pending in the U.S. District Courts in which the '315 Patent is asserted: *Goodman v. Hewlett-Packard Co.*, C.A. No. 16-CV-03195 (S.D. Tex.) (“HP Case”); *Goodman v. ASUS Computer International*, C.A. 17-CV-05542 (N.D. Cal. 05542) (Transferred from the S.D. Texas.); *Goodman v. Samsung Electronics America, Inc.*, C.A. No. 17-CV-05539 (S.D. N.Y.); and *Goodman v. Lenovo (United States) Inc.*, C.A. 17-CV-06782.

In addition, an IPR has been instituted against the present patent, U.S. Patent No. 6,423,315, by Samsung Electronics America, Inc. (Case IPR2017-02021) and ASUS Computer International, Inc. (Case IPR2018-00047).

II. THE CLAIMED INVENTIONS OF THE '315 PATENT

Fig. 1 of the '315 Patent is shown below. As stated in the '315 Patent at 5:41-42, “Fig. 1 is a block diagram of a preferred embodiment of the low power down memory system.”

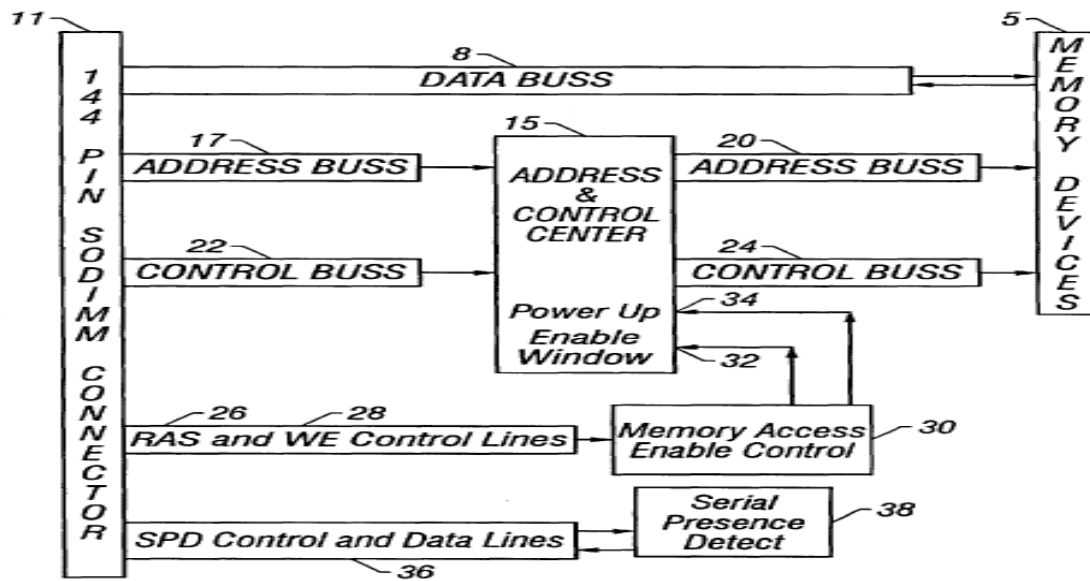

FIG. 1

The following is independent claim 1:

1. A memory system for use in a computer system, said memory system comprising:

a plurality of volatile solid state memory devices that retain information when an electrical power source is applied to said memory devices within a predetermined voltage range and capable of being placed in a self refresh mode; said memory devices having address lines and control lines;

a control device for selectively electrically isolating said memory devices from respective address lines and respective control lines so that when said memory devices are electrically isolated, any signals received on said respective address lines and respective control lines do not reach said memory devices; and

a memory access enable control device coupled to said control device and to said control lines for determining when said memory system is not being accessed and for initiating a low power mode for said memory system wherein said control device electrically isolates said memory devices and places said memory devices in said self refresh mode, thereby reducing the amount of electrical energy being drawn from an electrical power supply for said computer system. (Emphasis added)

The phrase “a control device ... “ has been highlighted to draw attention to this important aspect of the claimed invention. Electrically isolating the memory devices from the respective address lines and the respective control lines so that any signals on those lines do not reach the memory devices is critical for avoiding any corruptions of the data in the memory devices from unwanted signals during the self refresh mode.

The phrase “a memory access enable control device ...” has been highlighted to point to the important issue of when the low power down mode for the memory system starts: It starts when the memory system is not being accessed.

Claims 2-9 depend on claim 1.

Fig. 4 of the '315 Patent is shown below. The embodiment shown in Fig. 4 features a memory system with a backup battery to avoid a loss of data when the initial battery fails. In addition, data in the memory devices are protected against corruption when the initial battery is less than the minimum voltage to maintain the data in the memory devices. Claims 10-20 are directed to a system with battery backup.

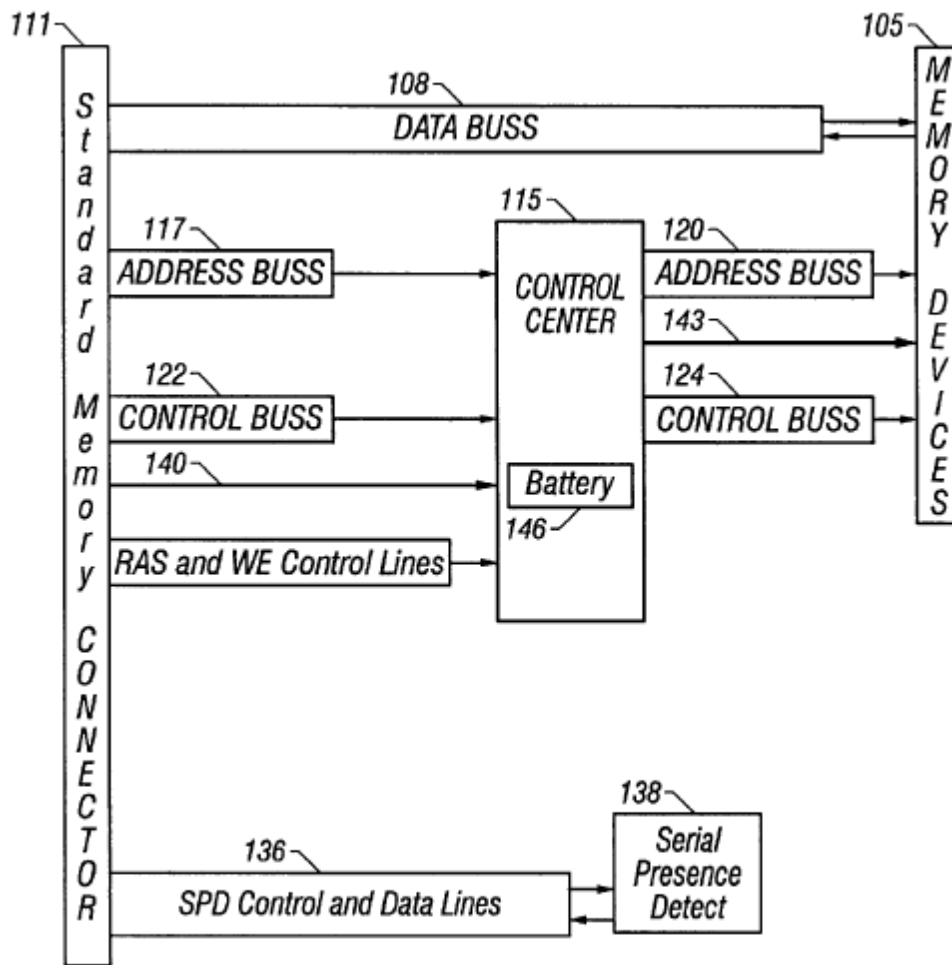

FIG. 4

The following is independent claim 10:

10. A memory system for use in a computer system, said memory system comprising:

a plurality of volatile solid state memory devices that retain information when an electrical power source having a voltage greater than a predetermined voltage is applied to said devices; said memory devices having address lines and control lines;

said computer system including a first electrical power source for operating said computer and being capable of producing a first voltage applied to said memory devices;

a control device for monitoring said first voltage to determine when said first voltage is less than said predetermined voltage and for selectively electrically isolating said memory devices from respective address lines and respective control lines so that when said memory devices are electrically isolated, any signals received on said respective address lines and respective control lines do not reach said memory devices; and

a second electrical power source operable for supplying a second voltage to said memory devices greater than said predetermined voltage;

said control device being operable for disconnecting said first electrical power source from said memory devices and connecting said second electrical power source to said memory devices when said first voltage is less than said predetermined voltage;

whereby, data in said memory devices is preserved by said second electrical power source when said first electrical power source fails to maintain at least said predetermined voltage on said memory devices, and said memory devices are isolated from errant signals. (Emphasis added)

The subsystem starting with “control device” has been made bold to draw attention to this particular feature. It is known in the prior art to use backup batteries and the like as an electrical power source in the event of a failure of the power source being used initially. The “control source” protects data in the memory devices when the first electrical power source is less than the minimum required for the memory devices by electrically isolating address and control lines from the memory devices so that errant signals cannot reach the memory devices and potentially

Explore Litigation Insights

Docket Alarm provides insights to develop a more informed litigation strategy and the peace of mind of knowing you're on top of things.

Real-Time Litigation Alerts



Keep your litigation team up-to-date with **real-time alerts** and advanced team management tools built for the enterprise, all while greatly reducing PACER spend.

Our comprehensive service means we can handle Federal, State, and Administrative courts across the country.

Advanced Docket Research



With over 230 million records, Docket Alarm's cloud-native docket research platform finds what other services can't. Coverage includes Federal, State, plus PTAB, TTAB, ITC and NLRB decisions, all in one place.

Identify arguments that have been successful in the past with full text, pinpoint searching. Link to case law cited within any court document via Fastcase.

Analytics At Your Fingertips



Learn what happened the last time a particular judge, opposing counsel or company faced cases similar to yours.

Advanced out-of-the-box PTAB and TTAB analytics are always at your fingertips.

API

Docket Alarm offers a powerful API (application programming interface) to developers that want to integrate case filings into their apps.

LAW FIRMS

Build custom dashboards for your attorneys and clients with live data direct from the court.

Automate many repetitive legal tasks like conflict checks, document management, and marketing.

FINANCIAL INSTITUTIONS

Litigation and bankruptcy checks for companies and debtors.

E-DISCOVERY AND LEGAL VENDORS

Sync your system to PACER to automate legal marketing.