

**(12) United States Patent**  
**Lewis et al.**

**(10) Patent No.: US 6,317,319 B1**  
**(45) Date of Patent: Nov. 13, 2001**

**(54) LOW-PROFILE COOLING ASSEMBLY FOR THE CPU CHIP OF A COMPUTER OR THE LIKE**

6,141,218 \* 10/2000 Miyahara ..... 361/695  
 6,205,027 \* 3/2001 Nakajima ..... 361/719

\* cited by examiner

**(75) Inventors: Jeffrey M. Lewis; Michael R. Rolla,**  
 both of Maynard; **Robert L. Sullivan,**  
 Townsend, all of MA (US)

*Primary Examiner*—Gregory Thompson  
**(74) Attorney, Agent, or Firm**—Cesari and McKenna

**(73) Assignee: Compaq Computer Corporation,**  
 Houston, TX (US)

**(57) ABSTRACT**

**(\*) Notice:** Subject to any disclaimer, the term of this patent is extended or adjusted under 35 U.S.C. 154(b) by 0 days.

A cooling assembly for cooling a CPU on a motherboard in a low profile electronic device. The assembly comprises a channel-shaped heat sink having a flat first wall, an opposite wall, open first and second ends and internal heat exchange fins extending between those walls and ends. An electric blower having an inlet and an outlet is mounted to the heat sink so that the blower outlet is aligned with the first end of the heat sink and the heat sink is anchored to the CPU so that the first wall of the heat sink is flush against the CPU and the blower inlet overhangs an edge of the motherboard. Preferably, a baffle member is mounted to the heat sink to direct heated air from the second end of the heat sink to the atmosphere and to prevent recirculation of that air back to the blower inlet.

**(21) Appl. No.: 09/626,204**

**(22) Filed: Jul. 26, 2000**

**(51) Int. Cl.<sup>7</sup> ..... H05K 7/20**

**(52) U.S. Cl. .... 361/695; 361/719; 454/184**

**(58) Field of Search ..... 165/80.3, 120-127;**  
 361/687-690, 694-695, 719-720; 454/184

**(56) References Cited**

**U.S. PATENT DOCUMENTS**

5,936,836 \* 8/1999 Scholder ..... 361/695

**7 Claims, 3 Drawing Sheets**

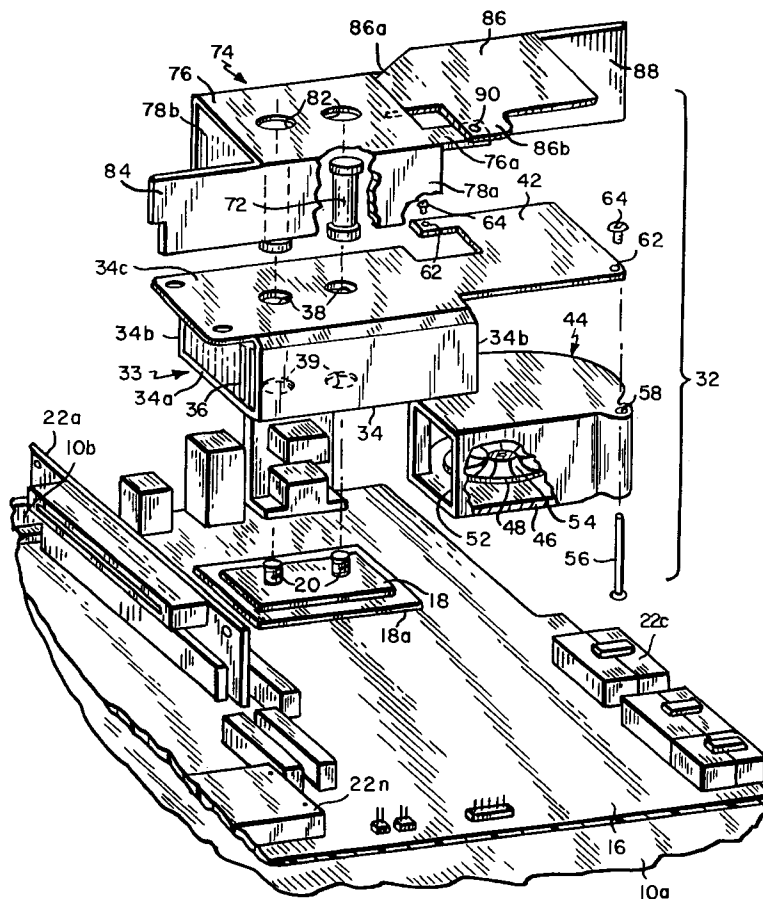

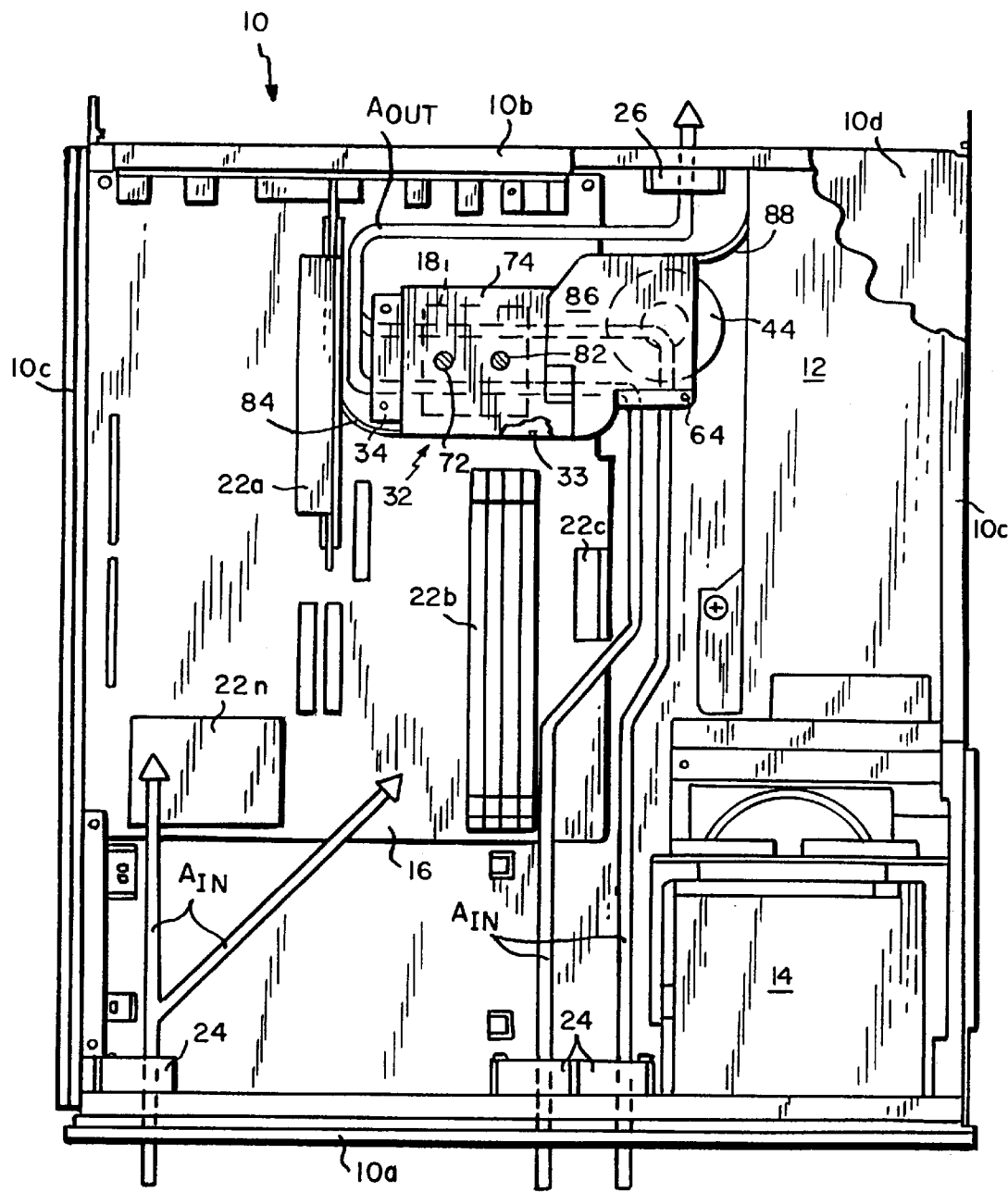

FIG. 1

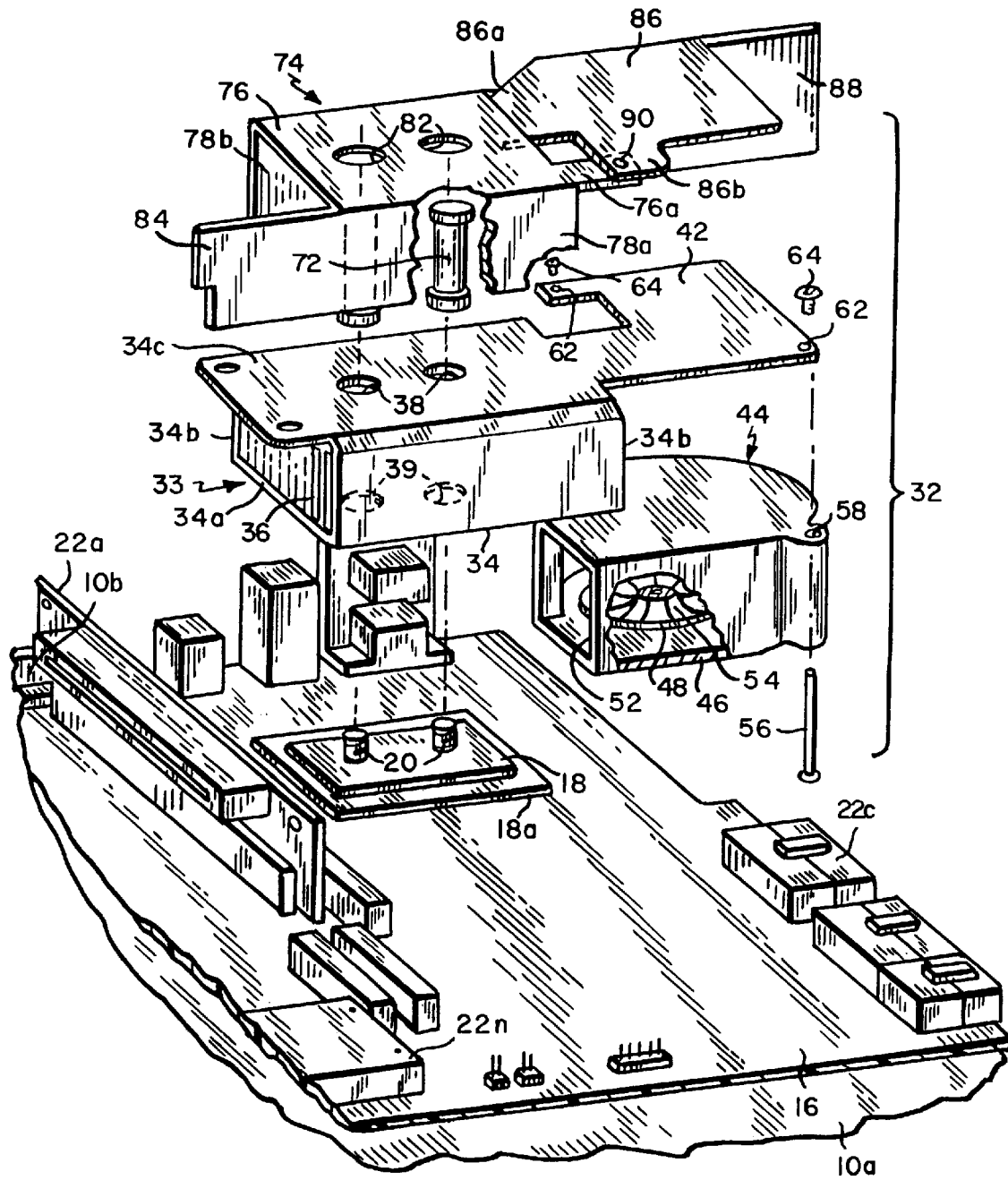

FIG. 2

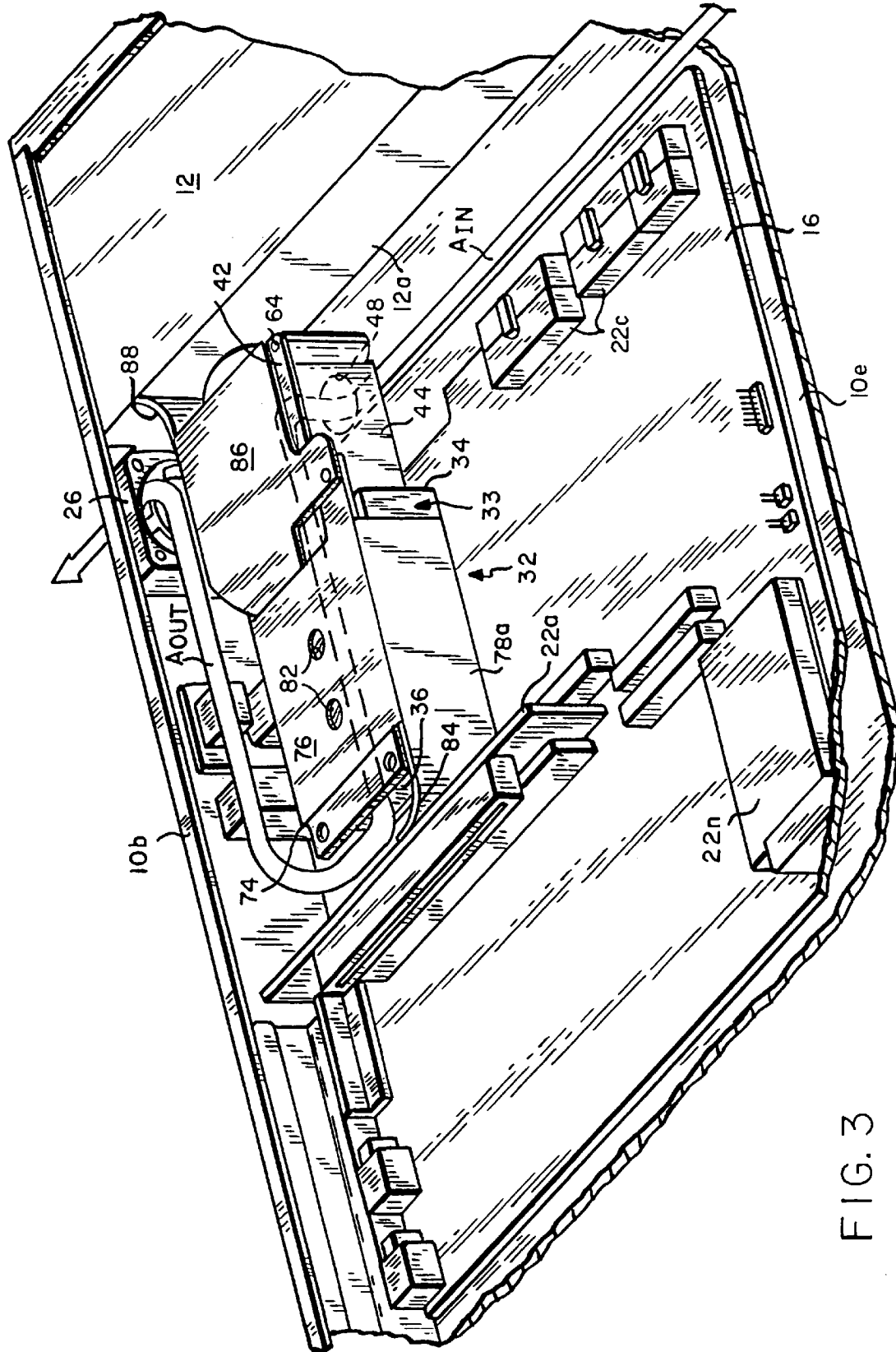

FIG. 3

# LOW-PROFILE COOLING ASSEMBLY FOR THE CPU CHIP OF A COMPUTER OR THE LIKE

## BACKGROUND OF THE INVENTION

### 1. Field of the Invention

This invention relates thin computers such as laptop and notebook computers. It relates especially to a low profile cooling assembly for the CPU chip in such computers.

### 2. Description of the Prior Art

The components of a computer, telecommunications switch or other microprocessor-based device are usually contained within an enclosure or housing. When the device is powered up, these components become heated. This is particularly so in the case of the device's central processor unit (CPU) which consumes a relatively large amount of electrical power. Therefore, such devices invariably include some means for circulating air through the enclosure to conduct heat away from those components, particularly the CPU chip.

For computers or other devices having a relatively high profile enclosure, it may suffice to provide fans at the perimeter of the enclosure to circulate air through the enclosure. However, for thin computers and devices it is usually necessary to supplement the perimeter fans with a fan or blower which conducts the cooling air directly to and from the CPU chip in the enclosure. While such cooling means operate satisfactorily in a computer enclosure in the order of five or more inches thick and which houses a relatively low power CPU chip, e.g. 70 watts or less, they do not suffice to cool higher rated chips in the low profile computers in use today, i.e. those less than two inches thick.

## SUMMARY OF THE INVENTION

Accordingly, it is an object of the present invention to provide an improved cooling assembly for cooling the CPU chip of a microprocessor-based electronic device.

A further object of the invention is to provide a cooling assembly for efficiently cooling a high power-rated CPU chip in a low profile computer.

Another object of the invention is to provide a cooling assembly for conducting heat away from a hot CPU chip located in a relatively thin enclosure.

Still another object of the invention is to provide an assembly of this type for directing a relatively large volume of air per minute past a high power-rated CPU chip housed in a densely packed enclosure.

Other objects will, in part, be obvious and will, in part, appear hereinafter. The invention accordingly comprises the features of construction, combination of elements and arrangement of parts which will be exemplified in the following detailed description, and the scope of the invention will be indicated in the claims.

Briefly, our cooling assembly is designed for use in an enclosure housing at least one CPU chip mounted to a motherboard within the enclosure. Typically, the enclosure has a low profile, e.g. 1.75 inches (1 U); however, it should be understood that aspects of the invention have application for taller enclosures. The assembly includes a thin-fin heat sink mounted directly to the top of the CPU chip, the heat sink being as tall as the enclosure will allow. Built into the heat sink are means to attached a centrifugal blower which is positioned as far away from the CPU as possible in order to maximize the fin length of the heat sink and so as to overhang the edge of the motherboard as much as possible to maximize the inlet opening into the blower.

Cooling air to be pulled into the inlet of the blower is provided by tube-axial fans mounted in a perimeter wall of the enclosure and which flood the interior of the enclosure with ambient air. This air is sucked into the blower and pushed laterally at a high velocity directly across the heat sink fins to draw heat away from the heat sink and thus from the CPU chip.

The assembly also includes flexible air baffles which direct the outlet air from the heat sink smoothly around corners to a tube-axial exhaust fan on the opposite wall of the enclosure from the inlet fans, these air baffles also providing top-to-bottom seals within the enclosure to prevent the heated air exhausting from the heat sink from being recirculated back into the blower.

As will be seen, the cooling assembly is easily installed in an enclosure less than two inches thick and, when installed, it can efficiently cool a CPU chip having a power rating of 80 watts or more.

## BRIEF DESCRIPTION OF THE DRAWINGS

For a fuller understanding of the nature and objects of the invention, reference should be made to the following detailed description taken in connection with the accompanying drawings, in which:

FIG. 1 is a plan view, with parts broken away, of a low profile computer incorporating a cooling assembly according to the invention;

FIG. 2 is a fragmentary exploded perspective on larger scale showing elements of the cooling assembly in greater detail, and

FIG. 3 is a fragmentary perspective view showing the fully assembled cooling assembly.

## DESCRIPTION OF THE PREFERRED EMBODIMENT

Refer to FIG. 1 which shows an enclosure indicated generally at **10** which houses the components of a microprocessor-based device, to wit: a computer. Enclosure **10** includes a front wall **10a**, a rear wall **10b**, a pair of opposite side walls **10c**, **10c**, as well as a top wall **10d** and a bottom wall **10e** (FIG. 3). Enclosure **10** is a so-called low profile enclosure having a height or thickness in the order of only two inches or less, e.g. 1 U.

The components inside enclosure **10** may include a power supply **12**, a disk drive **14**, as well as a motherboard **16** supporting a CPU chip **18** as well various other components **22a**, **22b**, **22c**, . . . **22n** such as integrated circuits, connectors, etc. Chip **18** is actually mounted to motherboard **16** via a base **18a** (FIG. 2). Also, for reasons that will become apparent, a pair of relatively large diameter threaded posts **20** project up from the top of the chip **18**. The motherboard also has various printed circuit paths (not shown) electrically interconnecting the various components of the computer.

One or more tube-axial fans **24** are mounted to the enclosure front wall **10a** for conducting cooling air into enclosure **10** as shown by the arrows  $A_{IN}$  and one or more exhaust or purging fans **26** are mounted to the enclosure rear wall **10b** to conduct heated air out of enclosure **10** as shown by arrow  $A_{OUT}$ .

In accordance with the invention, a low profile cooling assembly shown generally at **32**, positioned in enclosure **10** directly above CPU chip **18**, utilizes the incoming air streams from fans **24** to very efficiently and effectively conduct heat away from CPU chip **18** so that the chip may

# Explore Litigation Insights

Docket Alarm provides insights to develop a more informed litigation strategy and the peace of mind of knowing you're on top of things.

## Real-Time Litigation Alerts



Keep your litigation team up-to-date with **real-time alerts** and advanced team management tools built for the enterprise, all while greatly reducing PACER spend.

Our comprehensive service means we can handle Federal, State, and Administrative courts across the country.

## Advanced Docket Research



With over 230 million records, Docket Alarm's cloud-native docket research platform finds what other services can't. Coverage includes Federal, State, plus PTAB, TTAB, ITC and NLRB decisions, all in one place.

Identify arguments that have been successful in the past with full text, pinpoint searching. Link to case law cited within any court document via Fastcase.

## Analytics At Your Fingertips



Learn what happened the last time a particular judge, opposing counsel or company faced cases similar to yours.

Advanced out-of-the-box PTAB and TTAB analytics are always at your fingertips.

## API

Docket Alarm offers a powerful API (application programming interface) to developers that want to integrate case filings into their apps.

## LAW FIRMS

Build custom dashboards for your attorneys and clients with live data direct from the court.

Automate many repetitive legal tasks like conflict checks, document management, and marketing.

## FINANCIAL INSTITUTIONS

Litigation and bankruptcy checks for companies and debtors.

## E-DISCOVERY AND LEGAL VENDORS

Sync your system to PACER to automate legal marketing.