



US005987611A

United States Patent [19]
Freund

[11] **Patent Number:** **5,987,611**
[45] **Date of Patent:** **Nov. 16, 1999**

[54] **SYSTEM AND METHODOLOGY FOR MANAGING INTERNET ACCESS ON A PER APPLICATION BASIS FOR CLIENT COMPUTERS CONNECTED TO THE INTERNET**

Postel, J., "RFC 821—Simple Mail Transfer Protocol," Information Science Institute, University of Southern California, Aug. 1982, pp. 1–68.

(List continued on next page.)

[75] Inventor: **Gregor Freund**, San Francisco, Calif.

Primary Examiner—Robert W. Beausoliel, Jr.

[73] Assignee: **Zone Labs, Inc.**, San Francisco, Calif.

Assistant Examiner—Stephen C. Elmore

Attorney, Agent, or Firm—John A. Smart

[21] Appl. No.: **08/851,777**

[57] **ABSTRACT**

[22] Filed: **May 6, 1997**

A computing environment with methods for monitoring access to an open network, such as a WAN or the Internet, is described. The system includes one or more clients, each operating applications or processes (e.g., Netscape Navigator™ or Microsoft Internet Explorer™ browser software) requiring Internet (or other open network) access (e.g., an Internet connection to one or more Web servers). Client-based monitoring and filtering of access is provided in conjunction with a centralized enforcement supervisor. The supervisor maintains access rules for the client-based filtering and verifies the existence and proper operation of the client-based filter application. Access rules which can be defined can specify criteria such as total time a user can be connected to the Internet (e.g., per day, week, month, or the like), time a user can interactively use the Internet (e.g., per day, week, month, or the like), a list of applications or application versions that a user can or cannot use in order to access the Internet, a list of URLs (or WAN addresses) that a user application can (or cannot) access, a list of protocols or protocol components (such as Java Script™) that a user application can or cannot use, and rules to determine what events should be logged (including how long are logs to be kept). By intercepting process loading and unloading and keeping a list of currently-active processes, each client process can be checked for various characteristics, including checking executable names, version numbers, executable file checksums, version header details, configuration settings, and the like. With this information, the system can determine if a particular process in question should have access to the Internet and what kind of access (i.e., protocols, Internet addresses, time limitations, and the like) is permissible for the given specific user.

Related U.S. Application Data

[60] Provisional application No. 60/033,975, Dec. 31, 1996.

[51] **Int. Cl.**⁶ **G06F 13/00**

[52] **U.S. Cl.** **713/201**

[58] **Field of Search** 395/187.01, 186;
364/222.5, 286.4, 286.5; 711/163; 707/9,
10, 203; 713/200, 201

[56] **References Cited**

U.S. PATENT DOCUMENTS

4,914,586	4/1990	Swinehart et al.	364/200
5,475,817	12/1995	Waldo et al.	395/650
5,586,260	12/1996	Hu	395/200.2
5,623,601	4/1997	Vu	395/187.01
5,764,887	6/1998	Kells et al.	395/186
5,815,574	9/1998	Fortinsky	380/25
5,828,833	10/1998	Belville et al.	395/187.01
5,832,211	11/1998	Blakley, III et al.	395/188.01
5,838,903	11/1998	Blakely, III et al.	395/188.01
5,857,191	1/1999	Blackwell, Jr. et al.	707/10
5,864,665	1/1999	Tran	395/187.01
5,875,296	2/1999	Shi et al.	395/188.01
5,881,230	3/1999	Christensen et al.	395/200.33

OTHER PUBLICATIONS

Mullender, "Distributed Systems", Second Edition, ACM Press New York, Addison-Wesley, pp. 3. 12–13, 543–578, Dec. 1993.

ORFALI et al., "Essential Client/Server Survival Guide", Van Nostrand Reinhold, pp. 153–154, Dec. 1994.

30 Claims, 38 Drawing Sheets

220

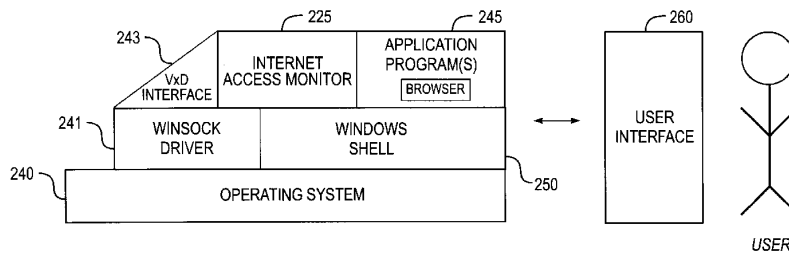

OTHER PUBLICATIONS

- Crocker, D., "RFC 822—Standard for the format of ARPA Internet Text Messages," Department of Electrical Engineering, University of Delaware, Aug. 13, 1982, pp. 1–47.
- Postel, J. and Reynolds, J., "RFC 959—File Transfer Protocol (FTP)," Information Science Institute, University of Southern California, Oct. 1985, pp. 1–47.
- Kantor, B. (U.C. San Diego) and Lapsley, P. (U.C. Berkeley), "RFC 977—Network News Transfer Protocol," Feb. 1986, pp. 1–27.
- Berners-Lee, T., "RFC 1630—Universal Resource Identifiers in WWW," Jun. 1994, pp. 28.
- Klensin, J., Freed, N., Rose, M., Stefferud, E. and Crocker, D., "RFC 1869—SMTP Service Extensions," Nov. 1995, pp. 1–11.
- Kessler, G. and Shepard, S., "RFC 1739—A Primer On Internet And TCP/IP Tools," Hill Associates, Inc., Dec. 1994, pp. 1–46.
- Myers, J. (Carnegie Mellon) and Rose, M. (Dover Beach Consulting, Inc.), "RFC 1939—Post Office Protocol—Version 3," May 1996, pp. 1–23.
- Freed, N., "RFC 2034—SMTP Service Extension for Returning Enhanced Error Codes," Innosoft, Oct. 1996, pp. 1–6.
- Freed, N., Borenstein, N., Moore, K., Klensin, J. and Postel, J., "RFC 2045/2046/2047/2048/2049—Multipurpose Internet Mail Extensions (MIME), Part 1: Format of Internet Message Bodies, Part 2: Media Types, Part 3: Message Header Extensions for Non-ASCII Text, Part 4: Registration Procedures, Part 5: Conformance Criteria and Examples," Nov. 1996, Part 1: pp. 1–31, Part 2: pp. 1–44, Part 3: pp. 1–15, Part 4: pp. 1–21, Part 5: pp. 1–24.
- Crispin, M., "RFC 2060—Internet Message Access Protocol—Version 4rev1," University of Washington, Dec. 1996, pp. 1–82.
- Palme, J. (Stockholm University) and Hopmann, A. (Microsoft Corporation), "RFC 2110—MIME E-mail Encapsulation of Aggregate Documents, such as HTML (MHTML)," Mar. 1997, pp. 1–19.
- Fielding, R. (U.C. Irvine), Gettys, J. (DEC), Mogul, J. (DEC), Frystyk, H. (MIT/LCS) and Berners-Lee, T. (MIT/LCS), "Hypertext Transfer Protocol—HTTP/1.1," Internet Engineering Task Force (IETF)—Internet Draft, Aug. 12, 1996, pp. 1–52.
- Marsh, K., "Win32 Hooks," Microsoft Developer Network Technology Group, Jul. 29, 1993 (revised Feb. 1994), pp. 1–14.
- Dawson, D., "Firewalls 101—A Introduction to Ascend Secure Access," Ascend Network Secure Business Unit, Sep. 4, 1996, pp. 1–6.
- Semeria, C., "Internet Firewalls and Security—A Technology Overview," 3Com Corporation, Sep. 4, 1996, pp. 1–16.
- Felten, E., Balfanz, D., Dean, D. and Wallach, D., "Web Spoofing: An Internet Con Game—Technical Report 540–96," Department of Computer Science, Princeton University, 1996, pp. 1–9.
- Microsoft Corporation, "Microsoft Technical Notes—Browsing and Windows 95 Networking," 1995, pp. 1–38.
- Windows Networking Design Team—Microsoft Corporation, "Microsoft TCP/IP VxD Interface Specification," Oct. 24, 1994, pp. 1–23.
- TechNet/Corp. Network Systems/Bus. Systems Div.—Microsoft Corporation, "MS Windows NT 3.5/3.51: TCP/IP Implementation Details," May 22, 1996, pp. 1–65.
- Shah, R., "Networking in Windows 95—SunWorld Online," Nov. 1, 1995, pp. 1–6.
- Rickard, J., "Internet Architecture," Boardwatch Magazine, 1996, pp. 1–11.
- Microsoft Corporation, "Active Directory Design Specification, Version 1.0," Oct. 25, 1996, pp. 1–111.
- Semeria, C., "Understanding IP Addressing—Everything You Ever Wanted To Know," NDS Marketing, 3Com Corporation, Apr. 26, 1996, pp. 1–62.
- Hall, M. et al., "Windows Sockets 2 Service Provider Interface, Revision 2.2.0," Stardust Technologies, May 10, 1996, pp. 1–200.

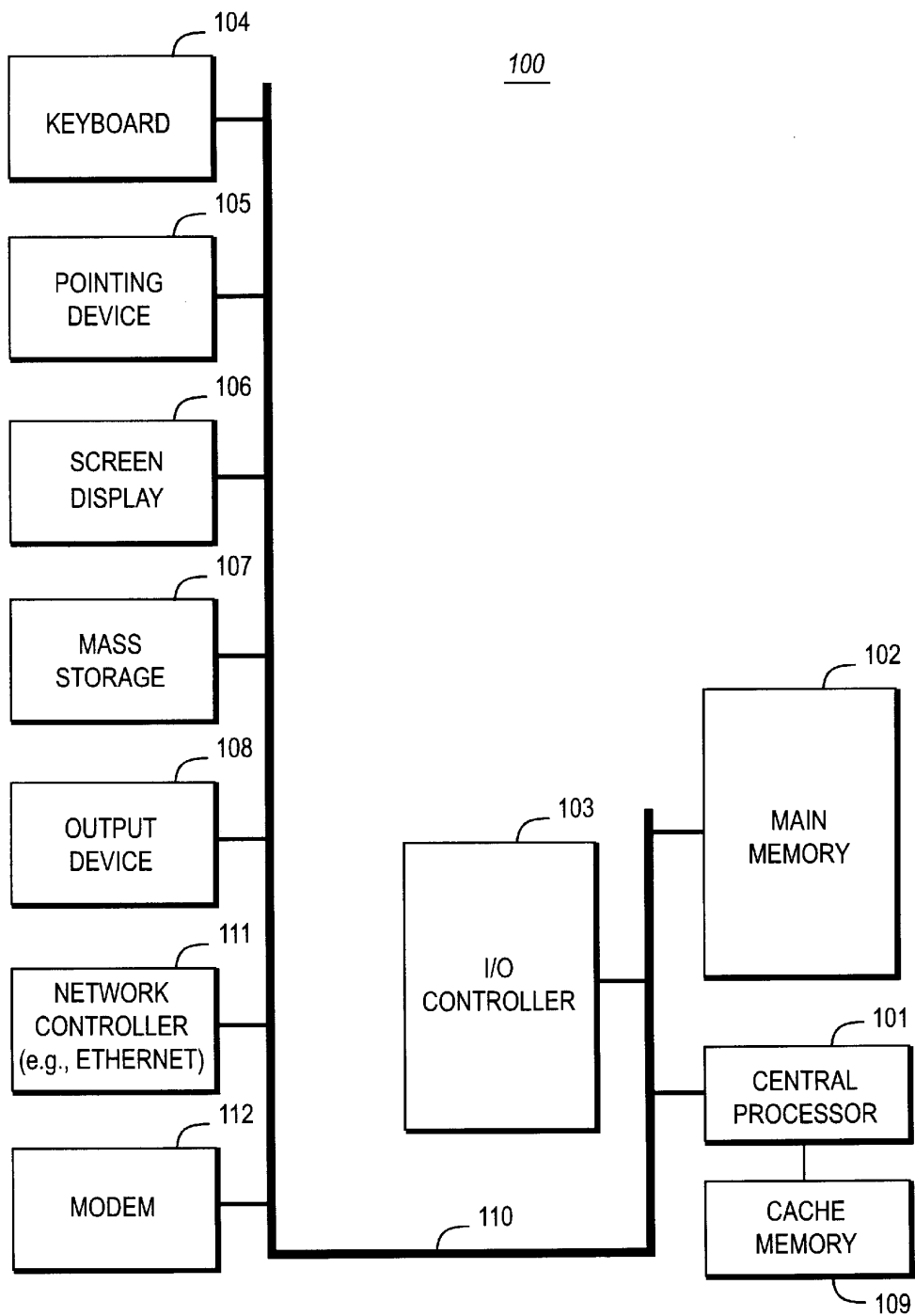

FIG. 1

220

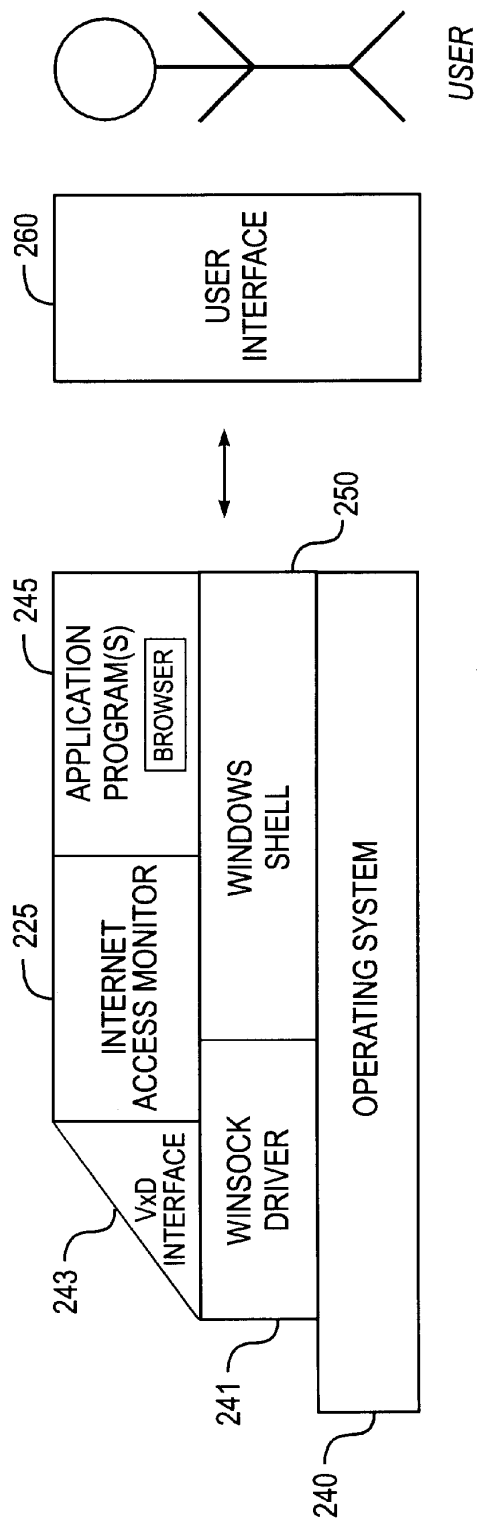

FIG. 2

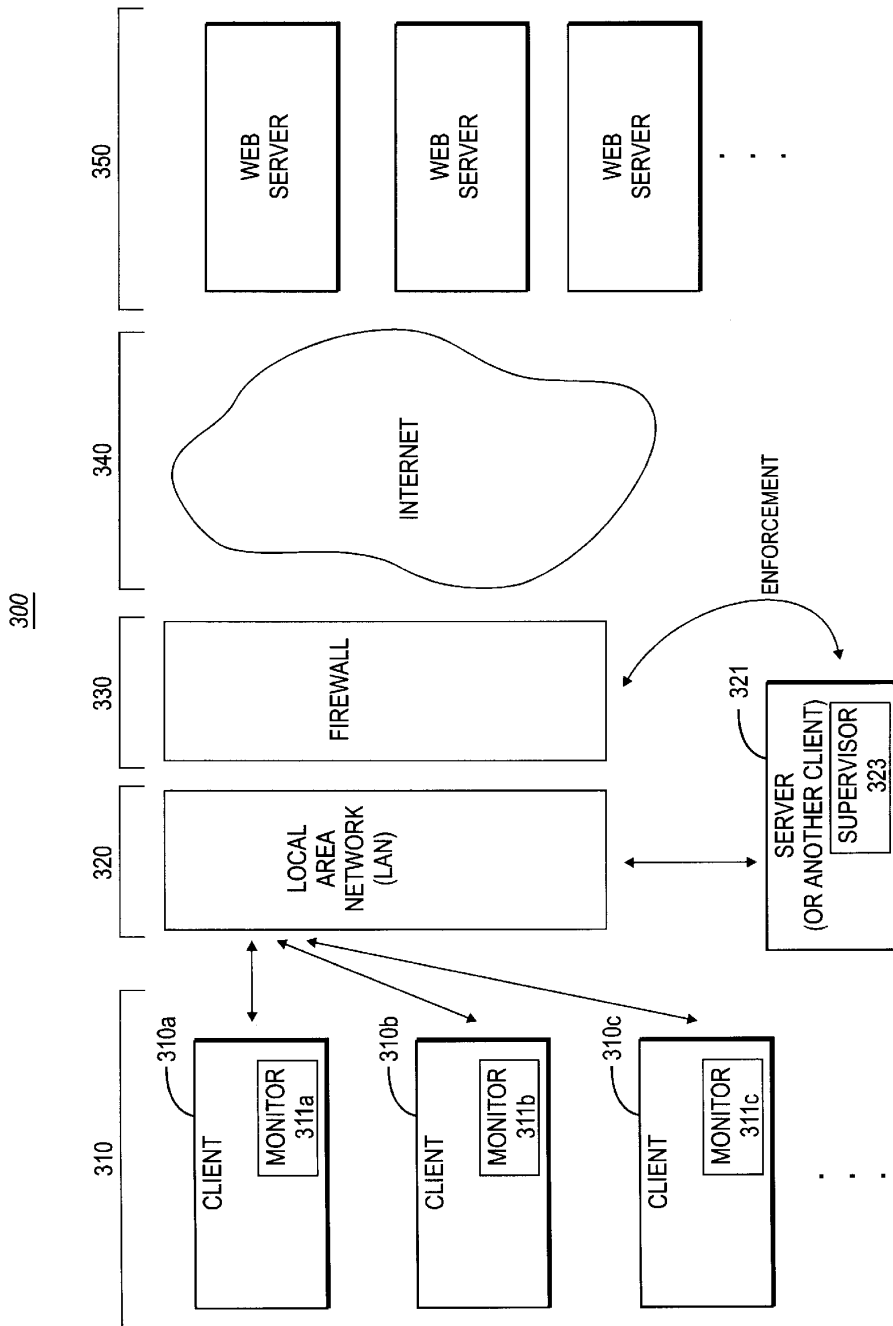

FIG. 3A

Explore Litigation Insights

Docket Alarm provides insights to develop a more informed litigation strategy and the peace of mind of knowing you're on top of things.

Real-Time Litigation Alerts



Keep your litigation team up-to-date with **real-time alerts** and advanced team management tools built for the enterprise, all while greatly reducing PACER spend.

Our comprehensive service means we can handle Federal, State, and Administrative courts across the country.

Advanced Docket Research



With over 230 million records, Docket Alarm's cloud-native docket research platform finds what other services can't. Coverage includes Federal, State, plus PTAB, TTAB, ITC and NLRB decisions, all in one place.

Identify arguments that have been successful in the past with full text, pinpoint searching. Link to case law cited within any court document via Fastcase.

Analytics At Your Fingertips



Learn what happened the last time a particular judge, opposing counsel or company faced cases similar to yours.

Advanced out-of-the-box PTAB and TTAB analytics are always at your fingertips.

API

Docket Alarm offers a powerful API (application programming interface) to developers that want to integrate case filings into their apps.

LAW FIRMS

Build custom dashboards for your attorneys and clients with live data direct from the court.

Automate many repetitive legal tasks like conflict checks, document management, and marketing.

FINANCIAL INSTITUTIONS

Litigation and bankruptcy checks for companies and debtors.

E-DISCOVERY AND LEGAL VENDORS

Sync your system to PACER to automate legal marketing.