

The Mouse in Biomedical Research

Volume III Normative Biology, Immunology, and Husbandry

EDITED BY

Henry L. Foster

The Charles River Breeding Laboratories, Inc.
Wilmington, Massachusetts

J. David Small

Comparative Medicine Branch
National Institute of Environmental Health Sciences
Research Triangle Park, North Carolina

James G. Fox

Division of Comparative Medicine
Massachusetts Institute of Technology
Cambridge, Massachusetts



ACADEMIC PRESS 1983

A SUBSIDIARY OF HARCOURT BRACE JOVANOVIICH, PUBLISHERS

New York London

Paris San Diego San Francisco São Paulo Sydney Tokyo Toronto

COPYRIGHT © 1983, BY ACADEMIC PRESS, INC.
ALL RIGHTS RESERVED.
NO PART OF THIS PUBLICATION MAY BE REPRODUCED OR
TRANSMITTED IN ANY FORM OR BY ANY MEANS, ELECTRONIC
OR MECHANICAL, INCLUDING PHOTOCOPY, RECORDING, OR ANY
INFORMATION STORAGE AND RETRIEVAL SYSTEM, WITHOUT
PERMISSION IN WRITING FROM THE PUBLISHER.

ACADEMIC PRESS, INC.
111 Fifth Avenue, New York, New York 10003

United Kingdom Edition published by
ACADEMIC PRESS, INC. (LONDON) LTD.
24/28 Oval Road, London NW1 7DX

Library of Congress Cataloging in Publication Data
Main entry under title:

The Mouse in biomedical research.

(American College of Laboratory Animal Medicine
series)

Includes indexes.

Contents: v. 1. History, genetics, and wild
mice -- [etc.] -- v. 3. Husbandry.

1. Mice as laboratory animals. I. Foster,
Henry L. II. Small, J. David. III. Fox, James G.
IV. Series. [DNLM: 1. Mice. 2. Research.

3. Animals, Laboratory. QI 60.R6 M9321]
QL737.R638M68 619'.93 80-70669
ISBN 0-12-262503-X (v. 3) AACR2

PRINTED IN THE UNITED STATES OF AMERICA

83 84 85 86 9 8 7 6 5 4 3 2 1

Chapter 18

Biomethodology and Surgical Techniques

Terrie L. Cunliffe-Beamer

I. Introduction	402
II. Handling, Identification, and Restraint	403
A. Handling	403
B. Identification	404
C. Restraint	404
III. Administration of Drugs or Other Compounds	404
A. Topical	404
B. <i>Per Os</i>	405
C. Subcutaneous Injection	405
D. Footpad Injection	406
E. Intracranial Injection	406
F. Intramuscular Injection	407
G. Intraperitoneal Injection	407
H. Intrathoracic Injection	407
I. Intravascular Injection and Cannulation	407
J. Medication of Neonatal Mice	408
IV. Collection of Biological Specimens	408
A. Bile	408
B. Blood	408
C. Bone Marrow	410
D. Feces	410
E. Lymph	411
F. Milk	411
G. Peritoneal Cells	411
H. Pulmonary Cells	411
I. Ova and Sperm	411
J. Urine	411
V. Assessment of Physiological Status	412
A. Blood Pressure, Heart Rate, and Respiratory Rate	412
B. Food and Water Consumption	412
C. Neurological Examination	412
D. Miscellaneous Techniques	412

This material may be protected by Copyright law (Title 17 U.S. Code)

VI.	Anesthetics	413
A.	Analgesics, Sedatives, and Other Preamanesthetic Medications	414
B.	Hypothermia	414
C.	Local Anesthetics	414
D.	Inhalent Anesthetics	414
E.	Injectable Anesthetics	416
F.	Neuroleptanalgesics	418
VII.	Surgical Procedures	419
A.	Basic Techniques	419
B.	Adrenalectomy	420
C.	Artificial Insemination	421
D.	Embryos and Embryo Transplants	421
E.	Hepatectomy	421
F.	Hypophysectomy	421
G.	Hysterectomy and Hysterotomy	422
H.	Isolated Intestinal Loops	423
I.	Lymphnodectomy	423
J.	Mammary Gland Excision and Transplant	423
K.	Miscellaneous Transplant Techniques	423
L.	Nephrectomy and Kidney Transplant	424
M.	Olfactory Bulb Ablation	424
N.	Orchidectomy, Testicular Biopsy	424
O.	Ovariectomy, Ovarian Transplant, and Ovariohysterectomy	425
P.	Parabiosis	425
Q.	Parathyroidectomy	426
R.	Pinealectomy	426
S.	Skin Grafts	426
T.	Splenectomy	426
U.	Thymectomy and Thoracotomy	427
V.	Thyroidectomy	427
W.	Vasectomy	428
VIII.	Postanesthetic and Postoperative Care	428
IX.	Euthanasia	428
X.	Diagnostic Procedures and Necropsy	429
A.	Diagnostic Procedures	429
B.	Necropsy	429
C.	Histopathological Examination	430
	References	430

I. INTRODUCTION

The mouse's small size, relatively short life span, proficient reproductive capabilities, and susceptibility to microbiological or chemical agents make it an appropriate animal model to investigate problems in many diverse disciplines, such as embryology, ethology, genetics, gerontology, microbiology, and oncology. The mouse's small body size makes it possible to maintain many mice efficiently and economically; however, this characteristic makes administration of drugs, collection of biological specimens, or performance of surgical procedures a challenge.

The objectives of this chapter are to (1) describe procedures for restraint, administration of drugs, and collection of biolog-

ical specimens or physiological data; (2) outline surgical procedures and appropriate anesthetic and postoperative care; (3) discuss advantages and disadvantages of alternative ways to perform the same procedure; and (4) provide references that contain detailed descriptions of unusual procedures.

Commonly used procedures and less common procedures for which descriptions could not be found in the literature are described in detail. In cases where good descriptions of unusual procedures are available in the literature, the reader will be referred to the original articles. Before attempting many of the procedures described in this chapter, one should review the anatomy of the area in question and practice the procedure on an anesthetized or dead mouse. Even though laboratory mice (*Mus musculus domesticus*) can be handled or restrained without the administration of drugs, one should not substitute phys-

ical restraint for analgesia during procedures that result in more than momentary pain.

II. HANDLING, IDENTIFICATION, AND RESTRAINT

A. Handling

Juvenile and adult mice are caught and picked up by grasping the base or middle third of the tail with fingers or smooth tipped forceps. Aggressive mice often climb their tails in order to bite fingers or forceps. Once caught by the tail, the mouse can be restrained for examination or injection by placing it on a table or cage lid, grasping the loose skin behind the neck and

ears with thumb and forefingers and holding the tail against the palm of the hand using the fourth and fifth fingers (Fig. 1). If the mouse can move his head from side to side, fingers may be bitten; however, by pulling the skin on the neck too tight, the mouse's airway is compromised.

Forceps (9–10-inch smooth dressing forceps) are an excellent way to manipulate wild, aggressive mice. Adult mice are caught by grasping the cranial third of the tail (Fig. 2). Mice should be lowered, not dropped, into a cage and released as soon as their front feet touch the bedding. Pregnant female mice approaching parturition or very large mice, e.g., homozygous obese (*oblob*) or diabetic (*db/db*) mice, should be handled gently and supported, if necessary, with a hand under their feet. Young mice (less than 2 weeks of age) are picked up by grasping the loose skin over the neck and shoulders with forceps or thumb and forefinger, or by scooping the litter into

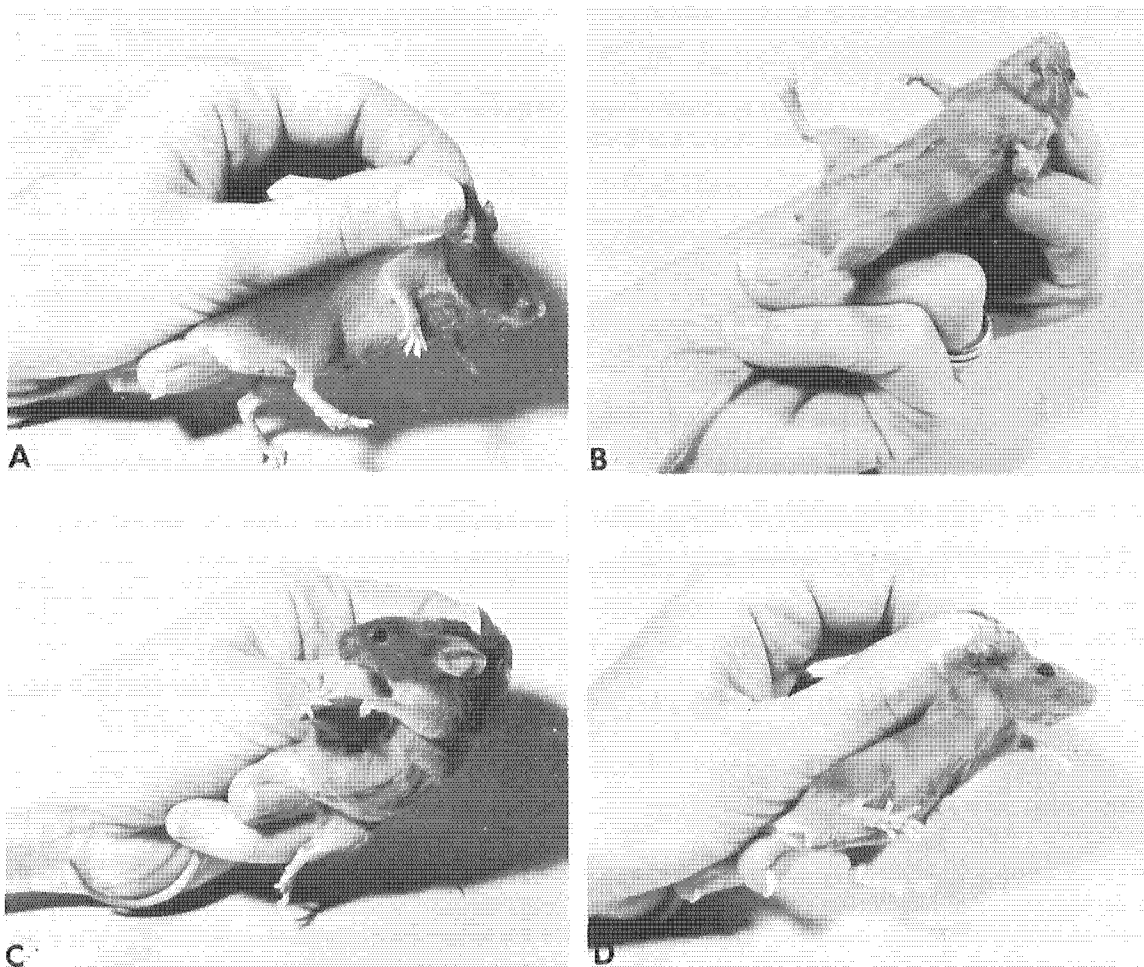

Fig. 1. Restraining a mouse by hand. (A) and (B) Proper finger placement. (C) Fingers are located over the mouse's shoulders, rather than behind neck and ears. The mouse can turn around and bite. (D) Excessive traction on the skin can choke the mouse. Note the protruding eyes.

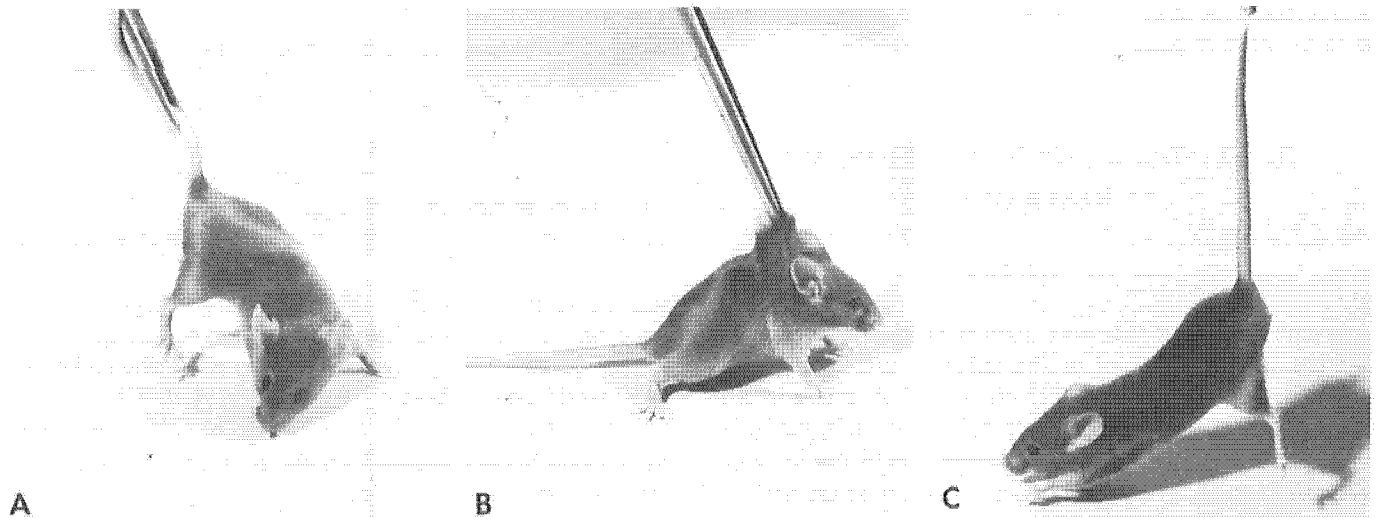

Fig. 2. Restraining a mouse using forceps. (A) Proper placement of forceps. (B) This mouse is too big to pick up over the shoulders. Forceps are grasping hair, not skin, and the hair may be plucked out by the weight of the mouse. (C) The tail slides through forceps if they are placed too close to the tip of the tail.

the palm of your hand. Newborn litters should be returned to a nest, not scattered throughout the cage, after they have been handled.

B. Identification

A variety of methods have been devised for permanent, or temporary identification of individual mice. Permanent identification methods include metal ear tags, notches (Dickie, 1975), toe clipping (Kumar, 1979; Dickie, 1975), tail clipping (Dickie, 1975), tattooing (Schoenborne *et al.*, 1977; Greenham, 1978; Avery and Spyker, 1977), and freeze marking (Farrell and Johnston, 1973). Duben (1968) devised a binary number system of toe clipping and ear notching that permitted individual identification of over 1,000,000 mice. Temporary identification of individual cagemates can be achieved by dyeing fur of albino or dilute mice with food coloring, clipping or plucking unique patterns in the fur, or marking tails with indelible markers. The first two methods permit identification for 1–2 weeks; ink marks disappear in 1–2 days.

C. Restraint

Restraint devices for mice have been made in many shapes using a wide variety of materials: hardware cloth (Oda and Miranda, 1976; Crispens and Kaliss, 1961), leather (Lawson *et al.*, 1966), plastic tubing (Mylrea and Abbrecht, 1967), 30–50ml plastic syringes (Lukasewycz, 1976; Furner and Mellett, 1975), metal dose syringe (Jones, 1965), radioisotope

shipping containers (Boutelle and Oper, 1967), scissor handles (Liebenberg *et al.*, 1980), and Plexiglas or metal (Archuleta, 1977; Billings, 1967; Boggs, 1978; Champlin and McGill, 1967; Kaplun and Wolf, 1972; Keighley, 1966; Mulder, 1979) (Fig. 3). Most of these devices were designed to facilitate tail vein injection, collection of blood, or irradiation. Regardless of the material, the device should prevent the mouse from turning around, have adequate air holes for ventilation, and should be easily cleaned and disinfected.

Wild mice (*Peromyscus* spp., *Mus caroli*, etc.) present special challenges for even the most routine animal care procedures. Forceps are mandatory for handling wild mice. In addition, one should consider using red light (Fall, 1974), working at odd hours when the animal room is quiet, and building a high-sided box or chute (Wallace, 1968).

III. ADMINISTRATION OF DRUGS OR OTHER COMPOUNDS

A. Topical

Topical application of compounds to depilated skin of the tail, ear, or the body of normal or genetically hairless mice, e.g., *hr/hr*, *nu/nu*, is an easy procedure. It is more difficult to prevent the mice from licking the area and ingesting the compound. Various devices have been developed for this purpose: Elizabethan collar (Einheber *et al.*, 1967), Plexiglas box applied with collodian (Nixon and Reer, 1973), glass tube over

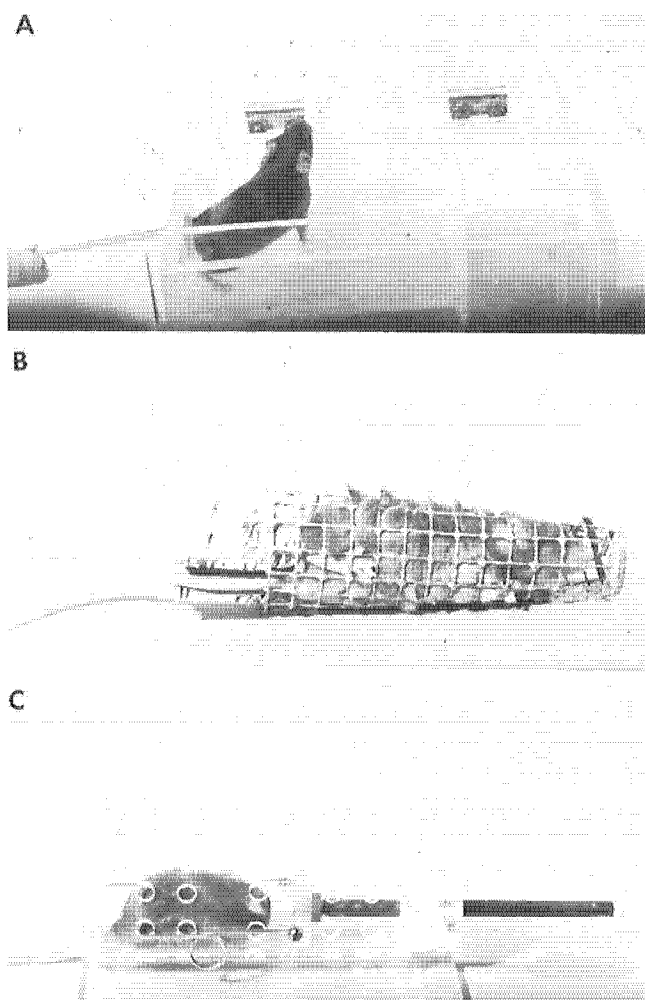

Fig. 3. Restraint devices. (A) Plexiglas box for tail bleeding. (B) Hardware cloth and cork mouse holder. (C) Plexiglas cylinder for irradiation or tail vein injection.

the tail (Jennings *et al.*, 1972), or a body bandage (Bryant and Bernard, 1955; Seibert and Pollard, 1973; Sedlacek *et al.*, 1970).

B. *Per Os*

The easiest, but least accurate, way to administer compounds *per os* is to mix them in the food or drinking water. However, if the compound imparts an unpleasant flavor to the food or water, food or water consumption is often drastically reduced. In one study water consumption decreased 43% following the addition of oxytetracycline to the drinking water (Stunkard *et al.*, 1971); the problem was eliminated by flavoring the water with sucrose. However, bottles of drinking water flavored with sugar should be replaced at least twice a week because of rapid

bacterial growth. If accurate oral administration of a compound is required, a feeding needle (Clark and Harland, 1969), dose syringe (Shani *et al.*, 1970), or continuous intragastric infusion system (Waynforth *et al.*, 1977) should be used. Successful *per os* administration of compounds requires thorough knowledge of the anatomical relationships of the oropharynx and deft touch because the esophageal orifice cannot be easily observed in the living mouse (Maceda-Sobrinho *et al.*, 1978) (Fig. 4). The mouse is restrained as shown in Fig. 1A, and the feeding needle is introduced into the left diastema and gently directed caudally toward the right rami of the mandible. At this point, the mouse usually begins to swallow and the feeding needle can be gently inserted into the esophagus (Fig. 5). If intragastric administration of the compound is desired, the diameter of the feeding needle or the tube should be small enough to pass through the esophagus where its diameter narrows near the heart. The length of the feeding needle or tube can be estimated by measuring the distance from the nose to the last rib. Extending the mouse's neck to form a straight line between esophageal orifice and the cardiac sphincter also facilitates intragastric administration of compounds.

C. Subcutaneous Injection

Subcutaneous injections (sc) of 1.0–2.0 ml per adult mouse are made into the loose skin over the neck or flank using a 20- to 26-gauge $\frac{1}{2}$ –1-inch needle (Fig. 6). The needle should be inserted into the skin $\frac{1}{4}$ – $\frac{1}{2}$ -inch caudal to the injection site and then advanced through the subcutaneous tissues to the injection site in order to minimize leakage of the injected material onto the pelage. Subcutaneous implants have been used to maintain transplantable tumors, create culture chambers (Arko, 1973),

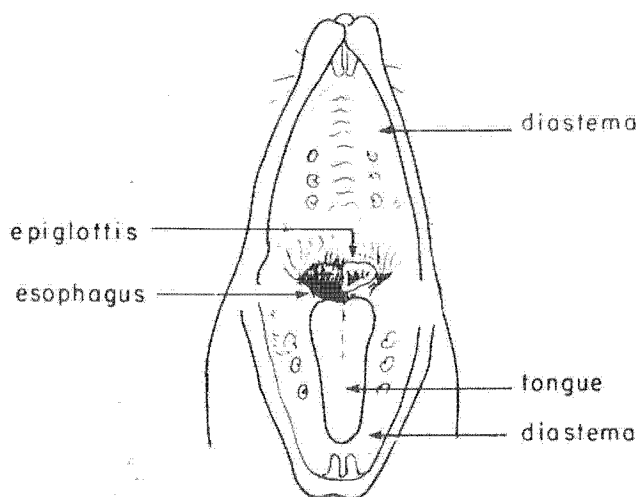

Fig. 4. Anatomical relationships of the oropharynx.

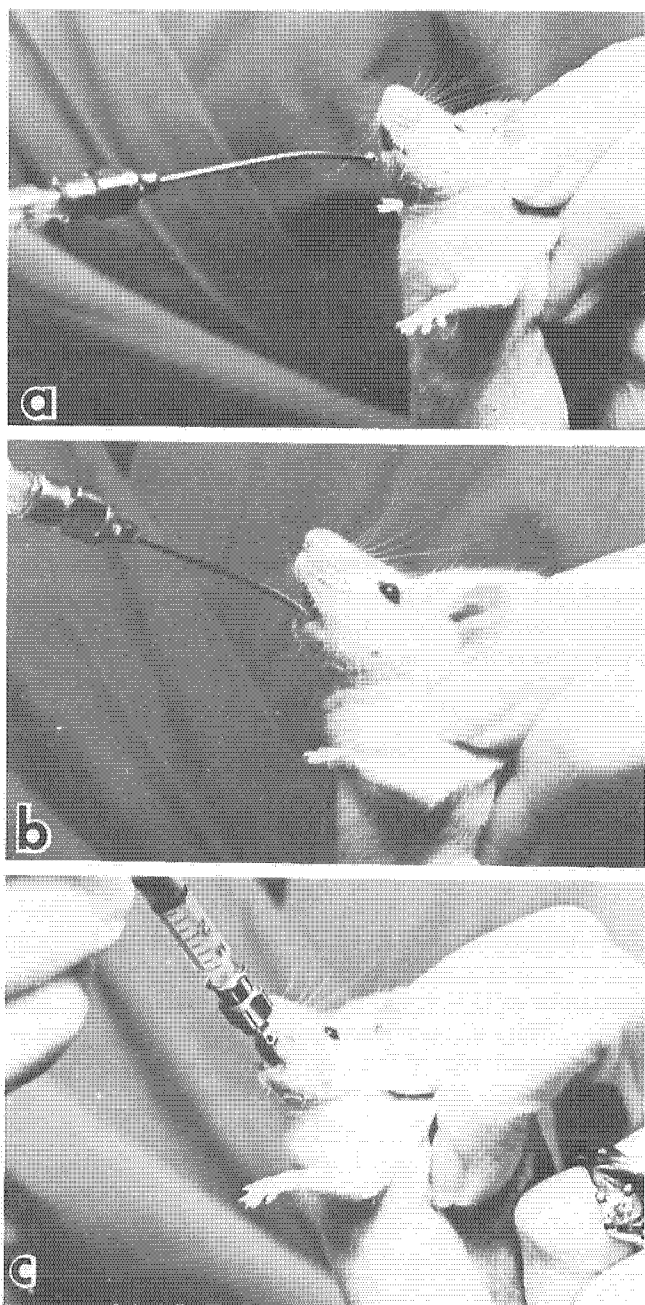

Fig. 5. Intra-gastric intubation. (a) Feeding needle and restrained mouse prior to insertion of the feeding needle. (b) Inserting the feeding needle into the left diastema. (c) Completing insertion of the feeding needle into the stomach.

induce tumors (Pregn and Karnik, 1979), culture endocrine organs *in vivo* (Krohn, 1963), or test materials for dental prosthesis (Russell *et al.*, 1979). Anesthesia is administered if the implant requires incision of the skin with scissors or use of a large 14-gauge trocar.

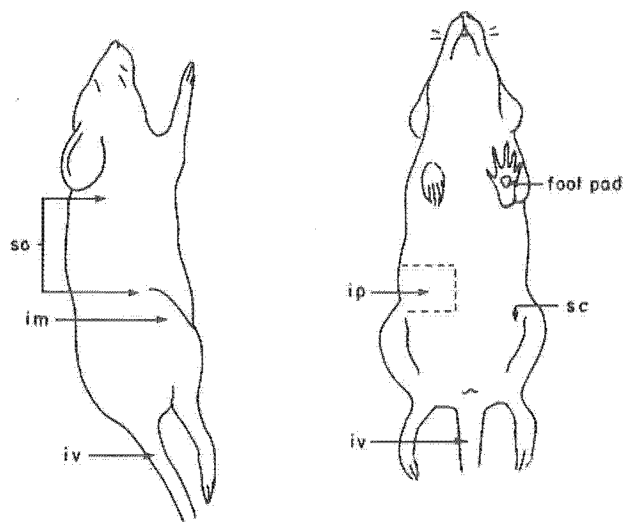

Fig. 6. Injection sites in the mouse. iv, intravenous; ip, intraperitoneal; sc, subcutaneous; im, intramuscular.

D. Footpad Injection

Injection into the volar aspect of the foot pad is used to elicit immunological responses. Up to 0.05 ml of inocula can be injected into a hindpaw (Nelson, 1973), and the response can be easily measured (Pearson *et al.*, 1971) (Fig. 6).

E. Intracranial Injection

Intracranial (ic) injection of suspect material into infant or weanling mice is used as an *in vivo* assay for neurotrophic viruses. Neonates are restrained with forceps; weanling mice should be anesthetized. The needle (27-gauge for neonate, 22- to 24-gauge for weanling) is inserted through the skin over the midsection of the parietal bone slightly lateral to the central suture; this avoids puncture of the sagittal or transverse venous sinuses. The needle is gently rotated until the bone is penetrated. Then the needle is advanced to a depth of 1–4 mm, depending upon the size of the mouse. Approximately 0.015 and 0.03 ml can be injected intracranially into neonatal and weanling mice, respectively (Johnson, 1974; Murine Virus Diagnostic Laboratory, 1978). Solutions injected intracranially should be as near body temperature as possible, and after injection mice should be kept warm to reduce the possibility of shock.

A technique for intracisternal injection into the cisterna magna of conscious mice was described by Ueda *et al.* (1979). A specially modified 27-gauge needle was used to inject 10–20 μ l. Intracerebroventricular injection of hormones or other pharmacologic agents into specific areas of the ventricles requires stereotaxic placement of the needle as described by Delahoy *et al.* (1978) and Holman (1980). Several stereotaxic

atlases of the mouse brain (Krueger, 1971; Lehmann, 1974; Montemurro and Dukelow, 1972; Sidman *et al.*, 1971) are available.

F. Intramuscular Injection

Intramuscular injections (im) are usually avoided in the mouse because of the small muscle masses. The rate of absorption of aqueous solutions is similar following intramuscular and subcutaneous injections (Baggott, 1977). If necessary, im injections of 0.05 ml or less may be made into the anterolateral thigh muscles (quadriceps femoris group) using a 22- to 26-gauge 1/4-inch needle (Fig. 6). The needle should be directed away from the femur and sciatic nerve.

G. Intraperitoneal Injection

To avoid puncturing the stomach, spleen, or liver intraperitoneal (ip) injections of up to 1.0 ml are made into the lower right quadrant of the ventral abdomen (Fig. 6). The mouse is restrained as shown in Fig. 1A, and the handler's wrist is rotated until the mouse's head and body are tilted in a downward direction, allowing the mouse's abdominal viscera to shift cranially. The needle (23- to 26-gauge 1/4-1/2-inch) is then inserted through the skin slightly medial to the flank and cranial to the inguinal canal, advanced cranially through subcutaneous tissue for 2-3 mm, and then inserted through the abdominal muscles. Care should be taken to avoid penetrating the preputial glands in the male mouse. The needle and syringe should be held parallel to the mouse's vertebral column in order to avoid accidental retroperitoneal or intrarenal injection. Further sources of error using intraperitoneal injections have been outlined by Lewis *et al.* (1966) and Hamilton *et al.* (1967).

H. Intrathoracic Injection

Unless experimental objectives mandate intrathoracic injection, intraperitoneal injection is preferred because it is easier and less hazardous (no risk of pneumothorax or punctured lungs), and absorption rates are similar. Intrathoracic injections, if necessary, are made at approximately the midpoint of the chest using a slightly bent 1/4-inch 22-gauge needle inserted at an angle between the ribs (Simmons and Brick, 1970).

I. Intravascular Injection and Cannulation

1. Intraarterial Injection

In certain procedures such as angiography, intraarterial injection may be necessary. Injection into the femoral artery

using a 1/2-inch 24-gauge needle has been described (Simmons and Brick, 1970), and techniques for carotid cannulation (McMaster, 1941; Sugano and Nomura, 1963a) can be adapted for intraarterial injection. To assure intraarterial injection, anesthesia is performed and the artery is exposed through a skin incision.

2. Intravenous Injection

The lateral or dorsal tail veins are the usual sites for intravenous injection in mice (Grice, 1964) (Fig. 6). Devices to restrain mice for tail vein injections are described by Crispens and Kaliss (1961), Champlin and McGill (1967), Boggs, (1978), Billings (1967), Furner and Mellett (1975), Lukasewycz (1976), Mylrea and Abbrecht (1967), and Nickson and Barkulis (1948). Tail vein injection is easier if the veins are dilated by warming the tail for 5-10 sec. in a jar of warm water (Barrow, 1968), or warming the mouse for 5-15 min. in a jar heated by a 40-100 W light bulb (Simmons and Brick, 1970). If necessary, tourniquets devised from a wound clip applicator (Bergström, 1971) or a hypodermic syringe and thread (Minasian, 1980) can be used to occlude tail veins. In albino or gray mice, the tail veins are visualized as thin red-blue lines coursing along the top (dorsal tail vein) and bottom (ventral tail vein). Tail vein injection of mice with pigmented tails is more difficult than injection of mice with nonpigmented tails. Depending upon the size of the mouse a 26- to 30-gauge 1/4- to 1/2-inch needle is used. Other sites for intravenous injections include the external jugular vein (Kassel and Levitan, 1953), dorsal metatarsal vein (Nobunaga *et al.*, 1966), sublingual vein (Waynforth and Parkin, 1969), and ophthalmic plexus (Pinkerton and Webber, 1964). Surgical exposure of these veins is not required.

3. Vascular Cannulation

The dorsal tail vein has been the usual site for intravenous cannulation in mice (Conner *et al.*, 1980; Moran and Straus, 1980; Rhodes and Patterson, 1979); depending upon the technique, anesthesia may or may not be required. Tail vein cannulas should be protected by bandages or splints.

The jugular vein is also accessible for intravenous cannulation after the mouse is anesthetized and placed in dorsal or dorsolateral recumbancy. After the skin is prepared for surgery, a 1-cm paramedian incision is made from the manubrium to the rami of the mandible. The caudomedial edge of the parotid salivary gland is dissected free, exposing the jugular vein and its fascial sheath. Incision of the fascial sheath exposes the jugular vein. The cannula can be inserted or direct injections can be made into the jugular vein using a 30-gauge needle. The volume injected should not exceed 0.1 to 0.2 ml. Post-injection hemorrhage is controlled by gently compressing the jugular vein with the end of the salivary gland as the needle is withdrawn from the vein.

Procedures for cannulation of the common carotid artery have been described by McMaster (1941) and Sugano and Nomura (1963a). After insertion, chronic carotid or jugular cannulas are routed subcutaneously across the lateral surface of the neck and exteriorized on the dorsal midline between dorsal borders of the scapulae. The abdominal aorta can be cannulated using the technique described by Weeks and Jones (1960). Exteriorized cannulas should be protected by a light weight body bandage. In some instances, a stanchion-like cage may be advised.

J. Medication of Neonatal Mice

Medication of neonatal mice is complicated because of their small size and the dam's tendency to reject or cannibalize offspring that have been handled excessively. Up to 0.1 ml may be administered orally through a piece of plastic tubing inserted over a 30-gauge needle. Subcutaneous injections of approximately 0.1 ml can be made over the neck and shoulders using a ¼-inch 30-gauge needle (Gibson and Becker, 1967). Leakage from intraperitoneal injections (0.05–0.1 ml) is minimized if the ¼- to ⅜-inch 30-gauge needle is inserted into the skin parallel to the right femoral vessels and advanced subcutaneously until the lower right abdominal muscles are penetrated. Intravenous injection of the neonatal mouse is difficult. Several authors have recommended the anterior facial vein at the level of the lateral canthus of the eye (Anderson *et al.*, 1959; Barnes *et al.*, 1963; Billingham and Brent, 1956) or the transverse (sigmoid) sinus (Barnes *et al.*, 1963). The latter injection site may be used until the mice reach 18–20 days of age. Intracardiac injection of newborn mice with up to 0.05 ml using 30-gauge needle has been described by Grazer (1958) and Postnikova (1960). Intracranial injection of neonates has been described previously (Section II,E).

The best defense against rejection or cannibalism of experimentally manipulated newborn mice is gentle handling of both neonate and dam. It is also helpful to select multiparous females that have successfully reared a litter and have demonstrated satisfactory maternal behavior, to select docile strains or stocks, and to separate dam and litter while the litter is being handled. Plastic gloves should be worn or an odor-masking agent (perfume) may be placed on the dam's nose and on the neonates to prevent them from acquiring or recognizing human scent. After injection or surgical manipulation, any extravasated blood is removed and the neonates are returned to their nest. East and Parrott (1962) described several surgical and postsurgical procedures for neonatal mice. Additional suggestions made by Libbin and Person (1979) for neonatal rat surgery can be applied to the mouse.

IV. COLLECTION OF BIOLOGICAL SPECIMENS

Sections VI, VII, and VIII should be consulted before attempting some of the more complex procedures described below.

A. Bile

Chronic cannulation of the bile duct of mice has been described, in detail, by Becker and Plaa (1967). Adaption of routine liver function tests for use in mice was described by Anonymous (1962) and by Casals and Olitsky (1946).

B. Blood

Many techniques for collecting large or small amounts of blood from mice have been developed.

1. Orbital Sinus

Venous blood can be easily obtained from the orbital sinus. The mouse is placed on a table or cage lid in lateral recumbancy, and its body is restrained against the table using the palm of one hand while the thumb and forefingers of the same hand restrain the head and gently open the eyelids to expose the eye. A microhematocrit tube or small bore Pasteur pipette is inserted through the conjunctiva of the medial canthus and is directed medially into the orbital sinus by quickly rotating the tube from side to side (Fig. 7). The eye is not damaged because the tube passes under the eye. Reluctant blood flow can be improved by raising or lowering the tube. This technique is usually performed on anesthetized mice.

After the required amount of blood is obtained, the tube is withdrawn and bleeding usually ceases. If necessary, hemorrhage can be controlled by direct pressure applied over the eyelids. Small amounts of blood (30–80 μ l) can be obtained from orbital sinuses of mice as young as 14–16 days of age. Larger amounts of blood (0.5 ml) can be obtained from orbital sinuses of older mice if tubes containing anticoagulant are used. Orbital bleeding can be repeated within hours if the amount of blood removed at any one time is relatively small. An alternative approach to orbital bleeding involves restraining the mouse in an upright position, as shown in Fig. 1A and B, and entering the venous sinus via the lateral canthus. This method provides less control over sudden movements of the mouse's head and increases the risk of corneal lacerations. Further descriptions of the technique can be found in articles by Cate (1969), Riley (1960), Stone (1954) and Simmons and Brick (1970).

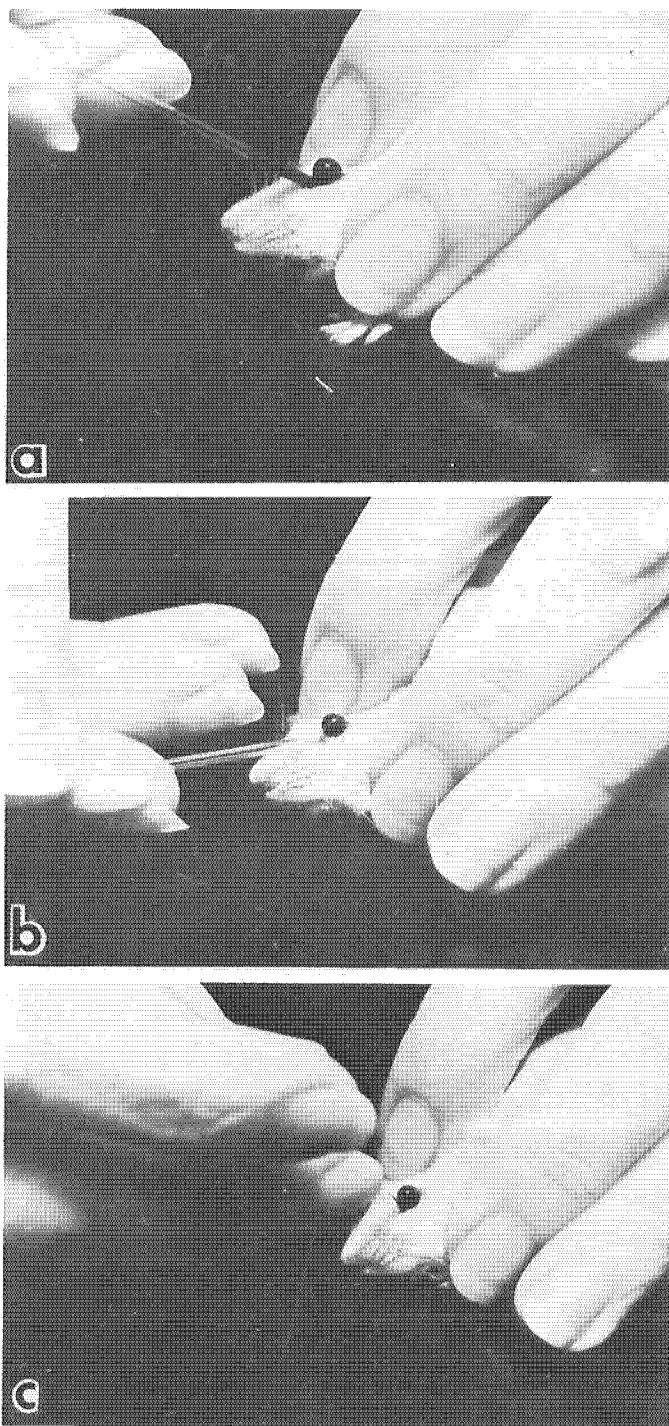

Fig. 7. Orbital sinus bleeding. (a) Correct angle for insertion of the microhematocrit tube. (b) Incorrect angle: Microhematocrit tube will lacerate the eye. (c) Incorrect angle: Microhematocrit tube presses against the orbital bones and does not enter the orbital sinus.

2. Tail Veins and Arteries

Tail veins and arteries may also be used as sources of blood. Tail bleeding is facilitated by immersing the tail in warm water or warming the mouse for 5–10 min in a cage covered by a goose neck lamp with a 50–100 W light bulb. Heparinization of the mouse prior to tail bleeding also increases the yield of blood (Lewis *et al.*, 1976). One technique involves amputating the tip of the tail of an anesthetized mouse with a scalpel blade (Stoltz and Bendall, 1975). Another technique involves incising the skin and ventral artery and veins of the tail approximately 0.5–2 cm from the base of the tail with a razor blade (Fields and Cunningham, 1976; Lewis *et al.*, 1976). One-half to 1 ml blood can be obtained using this technique. Small amounts of blood can be aspirated from tail veins following insertion of 30-gauge needle attached to 0.5- to 1.0-ml syringe (Grice, 1964). The latter technique is time-consuming compared to previously described methods.

Blood samples obtained from the orbital sinus and the tail are significantly different with respect to hematocrit and red and white blood cell counts but are not significantly different with respect to differential leukocyte count or polychromatic red blood cells. Less sample to sample variation in the above hematological parameters is observed in blood obtained from the orbital sinus compared to blood from the tail (Sakaki *et al.*, 1961).

3. Jugular Vein

Unadulterated venous blood can be obtained from the jugular vein by modifying the jugular injection technique of Kassel and Levitan (1953), or by surgically exposing and severing the jugular vein (Ambrus *et al.*, 1951).

4. Abdominal Aorta or Brachial or Carotid Arteries

Unadulterated arterial blood can be obtained from the abdominal aorta (Lushbough and Moline, 1961), brachial artery (Young and Chambers, 1973), or carotid artery (Ambrus *et al.*, 1951). All of the above procedures require anesthesia and result in the death of the mouse with the possible exception of carotid artery bleeding as described by Ambrus *et al.* (1951).

5. Heart

Large amounts of blood can be obtained directly from the heart using any of several different techniques. The technique described by Falabella (1967) utilizes manual restraint of the unanesthetized mouse and insertion of a 20-gauge needle at-

tached to polyethylene tubing through the midventral thorax into the heart. However, anesthesia should be administered prior to cardiac puncture. The anesthetic of choice for collection of blood for hematological examination is ether because it does not affect hematocrit, red blood cell count, white blood cell count, or differential cell counts (Grice, 1964). Cardiac puncture through the anterior thoracic aperture of anesthetized mice was described in detail by Frankenberg (1979). A third technique described by Simmons and Brick (1970) involves dorsal recumbant restraint of the anesthetized mouse and penetration of the thorax through the diaphragm under the xyphoid cartilage slightly to the left of the midline with a 20- to 25-gauge 1-inch needle attached to a 1- to 2-ml syringe. The needle and syringe are elevated 10° – 30° from the horizontal axis of the sternum (Fig. 8). In a fourth technique described by Cubitt and Barrett (1978), the heart is exposed via an incision in the ventral thoracic area and blood aspirated directly from the right ventricle. Unlike the three former techniques, this last technique results in the death of the mouse. Data presented by

Cubitt and Barrett (1978) indicate that blood collected using open and closed thorax methods is not identical.

C. Bone Marrow

Small amounts of bone marrow may be aspirated from the ilium (Sundberg and Hodgson, 1949), tibia (Sundberg and Hodgson, 1949), or sternbrae (Pilgrim, 1963) of an anesthetized mouse. Aseptic technique must be observed if sterile marrow or repeated samples are desired. Larger amounts of bone marrow are obtained by flushing or aspirating the marrow from the excised shaft of a disarticulated femur from a recently killed mouse.

D. Feces

Most mice urinate and defecate as soon as they are restrained, and 1–3 fecal pellets can be obtained. Alternatively,

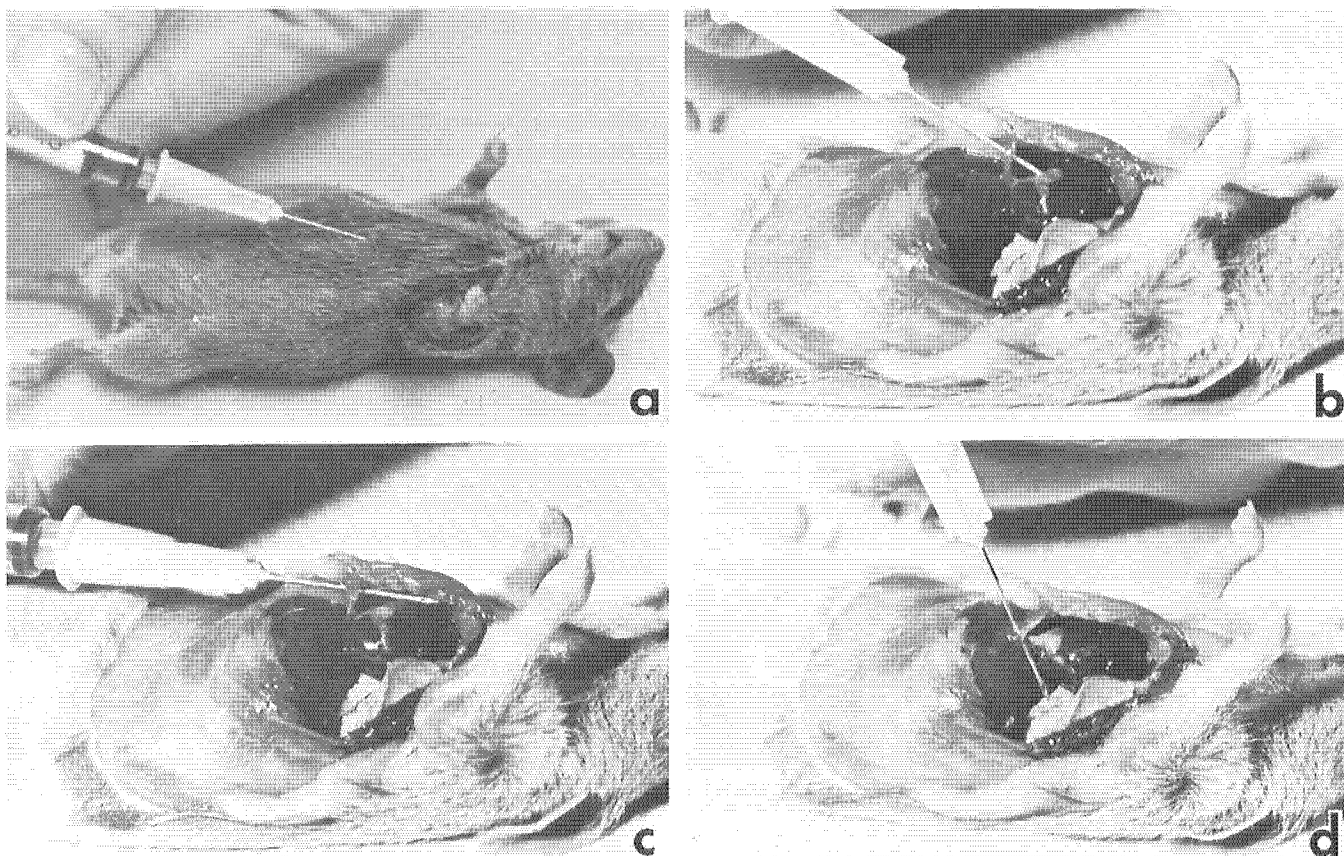

Fig. 8. Cardiac puncture. (a) Position of the anesthetized mouse prior to insertion of the hypodermic needle through the skin and diaphragm. (b) Dissected specimen: Correct angle of insertion of the needle. (c) Dissected specimen: Incorrect angle of insertion of the needle results in the needle passing over the heart. (d) Dissected specimen: Incorrect angle of insertion of the needle results in the needle passing under the heart and possibly penetrating the aorta, vena cava, or lung.

placing the mouse in a clean bedding-free cage or plastic cup for 1–3 hr usually results in the acquisition of small amounts of fresh feces. Metabolism cages may be used to collect larger amounts of feces over a 24-hr period (Rucklidge and McKenzie, 1980). However, all of the preceding methods potentially expose feces to urine. Uncontaminated feces can be obtained using anal cups (Ryer and Walker, 1971) or plastic bags and pipe cleaners (Roerig *et al.*, 1980).

E. Lymph

Chronic cannulation of the thoracic lymph duct caudal to the diaphragm was described by Boak and Woodruff (1965), Gesner and Gowans (1962), and Shrewsbury (1958). Successful execution of this procedure requires patience and meticulous attention to detail.

F. Milk

Mouse milking “machines” with single or multiple teat cups have been described by Feller and Boretos (1967), Haberman (1974), Kahler (1942), McBurney *et al.* (1964), and Nagasawa (1979). Prior to milking, the lactating female is separated from her litter for 8–12 hr, and mammary glands are washed with warm water. Milk flow can be stimulated by injecting 6.25 U oxytocin/kg body weight subcutaneously (Nagasawa, 1979) or 0.4 IU Pituitrin (Parke Davis Company)/kg body weight intraperitoneally (McBurney *et al.*, 1964) a few minutes before milking is attempted. The vacuum pressure of the milking “machine” is adjusted to 10–20 cm Hg, with rapid pulsation being necessary to achieve maximum milk yield. Peak lactation occurs between the twelfth and thirteenth day postpartum (Hanrahan and Eisen, 1971). Mice can be milked several times during the day and yield 0.7–1.0 ml per mouse (Kahler, 1942; McBurney *et al.*, 1964).

G. Peritoneal Cells

Peritoneal cells can be harvested by aseptically lavaging abdominal viscera with 6–15 ml warm isotonic saline or Hanks solution. The skin should be depilated and then decontaminated with 70% alcohol. The lavage solution is injected through a 19-gauge needle into flank just anterior to the coxofemoral joint (Nashed, 1975) or into the umbilical region (Chambers, 1975). Seventy to 90% recovery of injected fluid is expected. Anesthesia may or may not be required depending upon the volume of fluid injected, the skill of the operator and the temperament of the mouse.

H. Pulmonary Cells

Pulmonary cells can be harvested by bronchopulmonary lavage of anesthetized mice (Mauderly, 1977, or Medin *et al.*, 1976). An inhalant anesthetic is administered via laryngeal or tracheal cannula; wash volume should be predetermined for individual mice, but approximately 0.7 ml is used for adult mice.

I. Ova and Sperm

1. Ova

Collection of mature ova depends upon accurate identification of the stages of the estrous cycle of the female mouse. The estrous cycle was described in detail by Bronson *et al.* (1975), and photographs were presented by Champlin *et al.* (1973). Ovulation can be induced by administration of gonadotropins to the proestrus female mouse (Fowler and Edwards, 1957; Hoppe, 1976). However, age and strain markedly influence the female mouse's response to exogenous gonadotropins (Gates, 1971). Ova can be collected by excising the ovary and oviduct from a recently killed or anesthetized mouse and inserting a 30-gauge ½-inch needle attached to a 0.5 to 1-ml syringe filled with a warm isotonic solution into the distal end of the oviduct. The ova are flushed from the oviduct through the ovarian bursa into a watch glass (Gates, 1971; Hoppe and Pitts, 1973).

3. Sperm

Sperm can be obtained by electroejaculating male mice (Scott and Dziuk, 1959), expressing the vas deferens (Snell *et al.*, 1944), or mincing the epididymis (Southard *et al.*, 1965) of a recently killed male mouse. Secretions from the vesicular and coagulating glands coagulate electroejaculated semen unless these glands have been previously excised. Coagulation does not occur in semen obtained by expressing the vas deferens or mincing the epididymis. Sperm used for artificial insemination should be kept warm in a 5% CO₂ environment. Various media or solutions have been recommended as diluents (Hoppe, 1976; West *et al.*, 1977).

J. Urine

Most mice urinate as soon as they are restrained by hand. The spontaneously voided urine can be collected in a test tube held in the right hand while the mouse is being held in the left hand. Urine samples also may be collected in commercially available or homemade metabolism cages (West *et al.*, 1978) or in plastic bags held in place with a pipe cleaner harness as

described by Roerig *et al.* (1980). Evaporation or degradation of urine can be reduced by immersing the specimen bottle in crushed ice (West *et al.*, 1978), or adding toluene, thymol, formalin (Coles, 1974), or mineral oil to the urine sample.

V. ASSESSMENT OF PHYSIOLOGICAL STATUS

A. Blood Pressure, Heart Rate, and Respiratory Rate

Blood pressure of mice can be measured directly using carotid cannulation and pressure diaphragms (Sugano and Nomura, 1963a) or indirectly using occluding cuffs around the tail (Van Nimwegen *et al.*, 1973) or hindleg (McMaster, 1941). Return of circulation following release of the occluding cuff can be assessed by visual observation of the capillary circulation in the claw (McMaster, 1941), or use of photoelectric cells (Van Nimwegen *et al.*, 1973) or ultrasonic flow meters (Newman and Looker, 1972). In addition, Weeks and Jones (1960) technique for direct measurement of blood pressure in rats using aortic cannulas appears adaptable for use in mice.

Heart rate is measured using electrocardiograms or phonograms (Richards *et al.*, 1953) or estimated from recordings of blood pressure. Respiratory rates of mice are measured using electromyograms of the diaphragm (Sugano and Nomura, 1963b,c), pneumotachograms with glass face masks or tracheal cannulas (Sugano and Nomura, 1963b,c), or a light detector system (Beven, 1980). The first two procedures require anesthesia of the mouse; the last procedure utilizes a restraint tube and an unanesthetized mouse.

B. Food and Water Consumption

Mice quickly scatter powdered or pelleted feed and, thereby, frustrate attempts to accurately measure food consumption. Powdered diet or pellets can be dispensed inside the cage in screw capped specimen jars with a $\frac{3}{8}$ - to $\frac{1}{2}$ -inch hole drilled in the lid or modified beverage containers (Dunn and Stern, 1978). The mice have free access to food in these systems, but spillage and contamination with urine on feces are not completely controlled. Systems for more accurately dispensing granulated feed or powdered or pelleted diets have been described by Hunziker (1975), Morello and Nicholas (1969), and Koerker (1974). All of these feeders are constructed from readily available materials, and spillage or contamination are controlled to varying degrees. Spillage can also be controlled by adding agar base, e.g., 4% carrageenan (Kahn, 1966), or formulating the diet as a gel.

Accurate measurement of water consumption of a group of

mice in a cage requires a drip pan located under the drinking tube to catch drips as mice play with the tubes or as valves leak. Water consumption of individual mice caged in groups can be measured using a radioisotope label in the water (Toya and Clapp, 1972). Also, various electrical devices have been designed to monitor feeding or drinking frequency (Murakami and Imai, 1975; Saito and Takahashi, 1979; Sigdestad *et al.*, 1974).

C. Neurological Examination

Neurological examination of mice is difficult because of their small size. Careful visual observation of mice with suspected neurological defects is mandatory. Suspected vestibular abnormalities can be confirmed by placing a mouse in a pan of warm water and watching it swim (Hurley, 1968; Erway *et al.*, 1969). Normal mice instinctively know how to swim and hold their head above water. Placing reflexes can be evaluated by lifting the mouse by the back of the neck and tail and then lowering the mouse onto the top of a table. Normal mice reach for the table as soon as they see it and spread their toes when their feet touch the table. When picked up by their tails, normal mice abduct their hindlegs and spread their toes. Mice with neurological defects tend to adduct their hindlegs and curl their toes. Horizontal rotating rods may be used to detect disturbed equilibrium or muscular weakness (Seamer and Peto, 1969; Fuller and Wimer, 1975). Grip strength, extensor responses, and muscular strength can be evaluated using the miniature "bench presses" described by Cabe and associates (Cabe and Tilson, 1978; Cabe *et al.*, 1978). Open field tests may be used to screen for subtle behavioral deviations (Spyker *et al.*, 1972). Procedures to assess visual or auditory capabilities of mice were reviewed by Fuller and Wimer (1975). Higashi *et al.* (1979) described an apparatus that permitted recording of electroencephalographs in the free-moving mouse.

D. Miscellaneous Techniques

Body temperature can be measured using a copper-constantan thermocouple inserted in the colon to a depth of 3 cm (Barnett, 1956). If the mouse is held by the tail and the forefeet remain on a flat surface, body temperature remains constant; however, immobilization by the tail and scruff of the neck tends to depress body temperature (McLaren, 1961). Total body volume of a mouse can be estimated by using Boyle's law and displacement in water (Uchida *et al.*, 1973). Methods for determination of oxygen metabolism of mice are described by Mayer *et al.* (1950) and Furukawa *et al.* (1966). References describing other miscellaneous techniques can be found in the

following bibliographies: Snell and Hummell (1975) and Cass *et al.* (1960).

VI. ANESTHETICS

Many environmental and genetic factors alter the mouse's responses to anesthesia. These factors act through induction or depression of liver microsomal enzymes or other less well-defined physiological mechanisms. Factors that alter sleeptime following barbiturate anesthesia include cleanliness of the cage (Vesell *et al.*, 1976), type of bedding (Cunliffe-Beamer *et al.*, 1981; Ferguson, 1966; Vesell *et al.*, 1976), sex (Westfall *et al.*, 1964), strain (Vesell, 1968; Jay, 1955; Nebert and Gelboin, 1969), age (Vesell, 1968), environmental temperature, animal density, diurnal variation (Davis, 1962), and sensory stimulation (Vesell, 1968). Examples of effects of different beddings on barbiturate sleep-time are included in Table I.

General principles of anesthesia of laboratory animals, including mice, have been discussed by Taber and Irwin (1969), Green (1979), and McIntyre (1971). Regardless of the anesthetic selected or its route of administration, the depth of anesthesia must be accurately assessed in order to avoid problems associated with too much (depressed respiration, death) or too little (lack of analgesia, poor muscle relaxation, struggling) anesthesia. In mice, depth of anesthesia can be judged by failure to flick whiskers and ears in response to a puff of air (indicates minimal sedation), absence of eyelid or corneal reflexes (variable and hard to assess), failure to withdraw foot or tail in response to a pinch (indicates surgical anesthesia) and respiratory rate (dangerously depressed if less than 10 in 10 sec). Irrespective of the anesthetic selected, toe pinch and respiratory rate are the most consistent indicators of depth of anesthesia (Taber and Irwin, 1969; Greene and Feder, 1968; Tarin and Sturdee, 1972).

Anesthetics can be classified into two basic groups according to the route of administration. These groups are inhalant and injectable anesthetics. Inhalation anesthetics are in two basic

forms, gases (carbon dioxide and nitrous oxide) and volatile liquids (ether, enflurane, halothane, and methoxyflurane). In the past few years the hazards of exposure of personnel to waste anesthetic gases have been documented (Whitcher and Rock, 1978). Individuals using inhalant anesthetics for laboratory rodents should not ignore these potential hazards because most systems designed to administer inhalant gases to mice or rats use face masks, jars, or other nonbreathing devices that maximize the degree of anesthetic gas loss to the surrounding environment. One of the simplest ways to reduce exposure of personnel is to place the anesthetic system inside a fume hood or construct a scavenging system that connects to an exhaust vent.

A variety of methods for administration of inhalation anesthetics to mice have been devised. Ether can be administered in covered jars (Fig. 9), but the mouse must be removed as soon as it is anesthetized. Edwards *et al.* (1959) describe an ether chamber equipped with a bubbler that vaporized the ether. Tarin and Sturdee (1972) describe a system using a homemade vaporizer that administers methoxyflurane to two mice simultaneously. Nonbreathing systems for administering halothane or methoxyflurane have been described by Dudley *et al.* (1975), Mauderly (1975), and Smith *et al.* (1973). These systems utilize commercial vaporizers. A self-contained anesthetic chamber using soda lime to absorb exhaled carbon dioxide and a fan to circulate the methoxyflurane is described by Mulder and Brown (1972). Anesthetic chambers have also been described by Boutelle and Rich (1969), Hagen and Hagen (1964), and Heidt (1978). Green (1979) summarizes numerous articles describing very simple or very complex apparatuses designed to administer inhalation anesthetics to mice. Jaffe and Free (1973) describe a simple endotracheal intubation technique for rats. This technique may be adapted to large adult

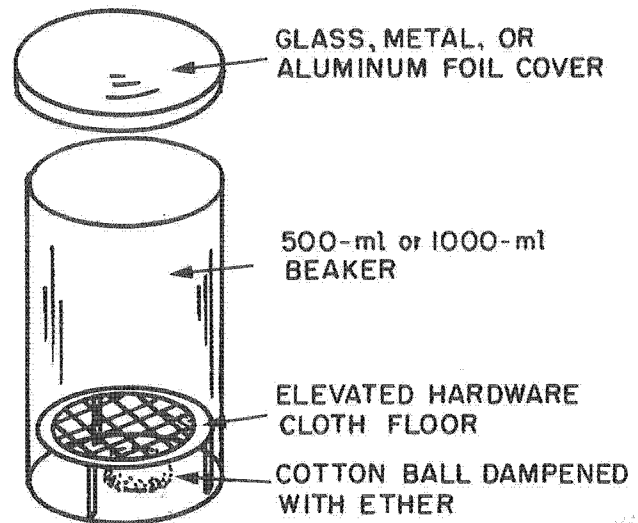

Fig. 9. Components of an ether jar.

Table I

Effect of Bedding on Pentobarbital Sleeptimes in Two Strains of Inbred Male Mice

Bedding	Sleeptime (min)	
	C57BL/6J	DBA/2J
Mixed hardwood	135 ± 6	161 ± 9
White spruce	123 ± 5	164 ± 10
White pine	85 ± 4	121 ± 6
Red cedar	56 ± 3	78 ± 5

^a Adapted from Cunliffe-Beamer *et al.* (1981).

mice. If a vaporizer is attached to the positive pressure respiration system developed by Siegler and Rich (1963b), this system could be used to administer inhalation anesthetics to mice.

Injectable anesthetics for mice are usually administered intraperitoneally. Many injectable anesthetics, e.g., pentobarbital, fentanyl, and chloral hydrate, are subject to United States Federal laws and drug enforcement agency regulations regarding storage, records, and disposal.

A. Analgesics, Sedatives, and Other Preanesthetic Medications

1. Analgesics and Sedatives

Analgesics and sedatives have not been widely used in mice, although they can be used in combination with other drugs to produce neuroleptanalgesia (Section IV,F). Dolowy *et al.* (1960) administered chlorpromazine prior to pentobarbital in an effort to reduce postanesthetic mortality. Large doses of chlorpromazine (25–50 mg/kg intramuscularly) were required. Taber and Irwin (1969) suggested that the dose of chlorpromazine should be reduced to 5–10 mg/kg subcutaneously in order to avoid tissue irritation. Barnes and Eltherington (1964) list recommended doses for mice of most of the common tranquilizers. C. J. Green (1975, 1979) concludes that diazepam at a dose of 5 mg/kg intraperitoneally is an excellent preanesthetic for mice and it has no effects on the cardiovascular system. Intraperitoneal injection of diazepam is recommended (C. J. Green, 1975) despite the fact that this drug is in an oil solution.

Morphine causes stimulation rather than analgesia in the mouse, especially at doses approaching 100 mg/kg subcutaneously (Chen *et al.*, 1966; Lumb, 1963). Barnes and Eltherington (1964) list the analgesic dose of morphine for mice as 7.0 mg/kg subcutaneously.

2. Atropine

Preanesthetic administration of atropine to reduce respiratory secretions, especially in conjunction with ether anesthesia, has been advocated by several authors. The recommended dose of atropine varies from 0.01 mg/mouse (Sjödén *et al.*, 1963), 0.04 mg/kg subcutaneously (Tarin and Sturdee, 1972; Weisbroth and Fudens, 1972), 1.2 mg/kg intraperitoneally (Delanoy *et al.*, 1978), to 10–20 mg/kg intraperitoneally (Taber and Irwin, 1969).

B. Hypothermia

Hypothermia is an excellent way to induce anesthesia in neonatal mice. Neonates (3 days of age or less) are removed, a

few at a time, from the nest, placed in a dry plastic ice cube tray or on a paper towel and transferred to the freezing compartment of a refrigerator (East and Parrott, 1962; Woolley and Little, 1945). The cooling time varies between 6 and 12 min. Anesthesia is complete when respiration is barely perceptible, response to stimulation is absent, and pink color is lost. The neonates are then removed from the freezer and placed on a cold glass plate. The surgical procedure should be completed within 3 min; repeating the cooling process is not advised. After surgery is completed, the neonates are revived by warming them under a lamp and stimulating respiration by gentle handling. They are returned to the nest as soon as breathing is regular and pink coloration is restored. Silva and Gras (1979) compared ether, pentobarbital, and cryoanesthesia (hypothermia) in neonatal Swiss mice undergoing thymectomy. The percent survival is significantly increased in neonates thymectomized under cryoanesthesia compared to neonates thymectomized under ether or pentobarbital anesthesia. In addition, they reported increased survival of cryoanesthetized neonates whose dams were anesthetized with pentobarbital during postoperative recovery of neonates compared to neonates returned to unanesthetized dams.

C. Local Anesthetics

Local anesthetics are not widely used in mice. Lidocaine hydrochloride (0.05 ml of 2% solution) injected into the base of the tail near the coccygeal nerves has been used to relieve pain associated with excision of tail tendon fibers (Harrison and Archer, 1978). The dosage is equivalent to approximately 1 mg per mouse. The intraperitoneal lethal dose that kills 50% of the mice (LD₅₀) for lidocaine is 133 mg/kg or approximately 3.9 mg per mouse (DeJong and Bonin, 1980). The subcutaneous LD₅₀ is expected to be several-fold higher because of slower systemic absorption (Lumb, 1963). Galloway (1968) injected procaine hydrochloride into mice and found that 10 mg/mouse intramuscularly killed 90% of the mice within 15 min, 5 mg/mouse killed 50% of the mice, 2.5 mg and 1.0 mg/mouse killed one of ten and none of ten mice, respectively. Similar doses of procaine administered as procaine penicillin G did not kill any of the mice.

D. Inhalant Anesthetics

1. Carbon Dioxide

Carbon dioxide narcosis provides sedation and analgesia for short procedures of 1–2 min duration (Abel and Bartling, 1978; Green, 1979; Taber and Irwin, 1969). Carbon dioxide is administered by placing the mouse in a jar filled with carbon

dioxide. Although it is difficult to control the depth of narcosis and some anesthetic deaths occurred using 100% CO₂, CO₂ is a good anesthetic for orbital sinus bleeding. The 1 : 1 CO₂ : O₂ mixture advocated by Fowler *et al.* (1980) may be a better choice, even though slightly more elaborate equipment is required. Rats undergoing CO₂ anesthesia struggled less, even though induction was slower, than rats undergoing ether anesthesia. Packed cell volume, urea, prothrombin, alanine aminotransferase activity, and plasma glucose were compared in rats under CO₂ or ether anesthesia. Only plasma glucose was altered (Fowler *et al.*, 1980). Similar comparisons for mice are not available. Carbon dioxide would not be an acceptable anesthetic if blood gas measurements are needed.

2. Chloroform

Chloroform, a volatile liquid, is contraindicated for anesthesia of mice because of the marked, often fatal, liver and kidney damage exhibited by certain strains of mice and potential hazards to personnel. Susceptible male strains have been found dead after accidental exposure to very small amounts of chloroform (Deringer *et al.*, 1953; Dunn, 1949a). Susceptible strains include DBA/2J and C3H/HeJ; resistant strains include C57BL/6J, C57BL/6JN, and BN. Hybrids between susceptible and resistant strains fall midway between the parental strains (Vesell *et al.*, 1976).

3. Enflurane (2-Chloro-1,1,2-trifluoroethyl difluoromethyl Ether)

Baden *et al.* (1980) studied that effects of exposure of Swiss ICR mice to 0.3% enflurane vapor for 4 hr/day, 5 days/week for 52 weeks. Exposed males had greater lymphocyte counts and lower reticulocyte counts; however, this difference was not considered to be biologically significant. Other blood cell counts were not significantly altered. Exposed mice weighed about 5% less than control mice. Chronic exposure to doses above 0.3% resulted in marked weight loss or death. Green (1979) reported variable results using enflurane to anesthetize mice.

4. Ether (Diethyl or Ethyl Ether)

Ether is a colorless, highly volatile, highly explosive, flammable liquid. It has a characteristic pungent odor and an irritating vapor (Lumb, 1963). Despite these disadvantages, it has been commonly used as an anesthetic for mice because of its ease of administration, rapid induction and recovery times, wide margin of safety, and low cost (Taber and Irwin, 1969). Ether is typically delivered via a jar or open container system (see Fig. 9). Mice should not be allowed to contact the liquid ether, since liquid ether on their fur can result in anesthetic

overdose and death can occur. Ether can also be administered using an open-drop system. An open-drop system can be made using a funnel or burette for an ether reservoir and a mouse size face mask made from hardware cloth or the barrel of a 5–10 ml syringe. One end of the face mask should be covered with gauze onto which a small amount of ether is constantly dripped through rubber tubing with an adjustable clamp. The other end of the face mask remains open and the mouse's nose is inserted into this opening. This system permits administration of a constant drip of ether to the face mask. To prevent unnecessary exposure of personnel and reduce risks of explosion, ether jars or open-drip systems should be placed in or vented to an explosion proof hood.

Tarin and Sturdee (1972) concluded that ether is unsuitable because of (1) the risk of explosion, (2) respiratory irritation and copious secretions that caused airway obstruction and (3) difficulty maintaining a consistent level of surgical anesthesia. Atropine sulfate did not completely eliminate problems with excessive respiratory secretions. In the author's experience, ether is the anesthetic of choice for adult obese (*ob/ob*), adult diabetic (*db/db*), and previously hypophysectomized mice. Buchsbaum and Buchsbaum (1962) studied the influence of age upon induction and recovery times of mice. Very young and very old mice have longer recovery times than middle aged mice. Ether anesthesia does not alter hematocrit, red or white blood cell counts or differential cell counts (Grice, 1964).

5. Halothane

Halothane is a nonexplosive, nonflammable, volatile liquid anesthetic (Lumb, 1963). However, without a vaporizer, it is difficult to control anesthesia because small changes in the concentration of halothane produce large changes in depth of anesthesia. Dudley *et al.* (1975) and Smith *et al.* (1973) designed a nonbreathing semi-closed vaporizer system for administering halothane to mice. As with ether, these systems should be used in a fume hood or fitted with scavenging devices. Tarin and Sturdee (1972) concluded that halothane was not a good choice for anesthetizing mice because the margin between surgical anesthesia and anesthetic overdose was small, even if a second person acted as an anesthetist. Hagen and Hagen (1964) also reported problems controlling the depth of halothane anesthesia in mice. However, postoperative survival after halothane anesthesia is excellent (Tarin and Sturdee, 1972). In addition halothane does not inhibit gonadotropin-induced ovulation of immature mice (Bell *et al.*, 1971).

6. Methoxyflurane

Methoxyflurane is a volatile and nonexplosive liquid at room temperature (Lumb, 1963). Surgical anesthesia can be induced

by a beaker with a wick (Greene and Feder, 1968) or bubblers made from common laboratory glassware (Hagen and Hagen, 1964; Tarin and Sturdee, 1972); methoxyflurane should be used in a fume hood or the vaporizing system should be fitted with scavenging devices. Tarin and Sturdee (1972) cited several advantages for methoxyflurane: (1) surgical anesthesia is easy to maintain, (2) level of anesthesia is easily assessed by toe pinch or counting respiratory rate, and (3) postoperative survival is high. Induction and recovery times are relatively long, however, 10–20 min depending upon the length and concentration of exposure (Hagen and Hagen, 1964; Tarin and Sturdee, 1972). The long induction and recovery period can be an advantage if experimental protocols require anesthetizing several mice at once and then removing them from the anesthetic system for short procedures. Wharton *et al.* (1980) studied the teratogenic effects of chronic exposure to trace, sub-anesthetic, and anesthetic doses of methoxyflurane. Chronic exposure to an anesthetic concentration (0.2%) results in decreased fetal weight, decreased ossification, and delayed renal maturation of Swiss ICR mice. This fact should be considered if experimental protocols require repeated anesthesia of pregnant mice.

7. Nitrous Oxide

Nitrous oxide is a nonexplosive nonirritating gas that is quickly absorbed and excreted. If administered with sufficient oxygen (15% O₂) and in a high enough concentration (80% NO₂), nitrous oxide can be a satisfactory anesthetic for minor surgery (Lumb, 1963). Mauderly (1975) anesthetized mice and other laboratory rodents using a 5% halothane in equal parts nitrous oxide and oxygen mixture. A recent report (Lane *et al.*, 1980) indicates that nitrous oxide is fetotoxic and teratogenic for rats.

E. Injectable Anesthetics

1. Alphaxolone–Alphadolone

Green *et al.* (1978) reported that this combination of steroids provided excellent anesthesia for periods of up to 4 hr when administered intravenously. The initial dose was 14–20 mg/kg followed by 4–6 mg/kg at 15 min intervals as needed. Repeated intravenous injections were made through a lateral tail vein cannula. Tolerance or cumulative effects have not been observed. The degree of anesthesia is variable when these drugs are administered intramuscularly at 60–150 mg/kg. Intraperitoneal injection of 120 mg/kg produces more consistent muscle relaxation than intramuscular injection, but this dose approaches the intraperitoneal LD₅₀ of 180–200 mg/kg. Analgesia is poor following intraperitoneal administration.

2. Chloral Hydrate

In situations where a prolonged period of deep sedation is required, chloral hydrate may be a satisfactory anesthetic for mice. Intraperitoneal chloral hydrate has been used by Corry *et al.* (1973) and Skoskiewicz *et al.* (1973) to anesthetize mice prior to heart and kidney transplants. Barnes and Eltherington (1964) recommend 400 mg/kg intraperitoneally. With C57BL/6J male mice, a slightly higher dose (480 mg/kg) is more satisfactory (T. L. Cunliffe-Beamer unpublished observations). A fraction of the original dose can be repeated if prolonged anesthesia is necessary. Adynamic ileus can occur in the rat following intraperitoneal administration of concentrated chloral hydrate solutions (Fleischman *et al.*, 1977).

3. Pentobarbital Sodium

In mice, pentobarbital is one of the most commonly administered parenteral anesthetics. Recommended doses for intraperitoneal administration to postweanling mice vary from 40 mg/kg (Taber and Irwin, 1969), 50 mg/kg (Westfall *et al.*, 1964), 60 mg/kg (Barnes and Eltherington, 1964; Delanoy *et al.*, 1978), 80 mg/kg (Ferguson, 1966) to 85 mg/kg (Falconi and Rossi, 1964; Lostroh and Jordan, 1955). Taber and Irwin (1969) recommend 5 mg/kg intraperitoneally for mice between 1 and 4 days of age. As previously mentioned, many physiological and environmental variables alter sleeptime following administration of pentobarbital or other barbiturate anesthetics. The effects of strain, age and sex on barbiturate sleep times of mice are summarized in Table II. Mice from different strains differ markedly in their responses to a single injection of a barbiturate anesthetic. Neonatal mice are very susceptible to barbiturate anesthetics. Seven day's difference in age can markedly alter response to barbiturate anesthesia. In general, male mice remain anesthetized longer than female mice. This sex difference appears to be dependent upon gonadal steroids.

Commercial solutions of pentobarbital must be diluted before they can be administered to mice. Dilutions are made with sterile saline or water. One part pentobarbital in a final volume of eight to ten parts is used when diluting pentobarbital solutions for use in mice. Some authors (Lostroh and Jordan, 1955; Pilgrim, 1969) recommend incorporating propylene glycol and alcohol in the diluent; Pilgrim's diluent is steam sterilizable. A diluent composed of 2 ml propylene glycol, 1 ml ethyl alcohol, and 6 ml water per milliliter of commercial pentobarbital solution seems to increase sleeptime of DBA/2J male mice compared to a 1:10 dilution of pentobarbital in water. Necropsy of the mice 30–72 hr after anesthesia revealed that mice receiving the pentobarbital in the propylene glycol–alcohol–water diluent tended to have greater swelling and congestion in the abdominal fat than mice receiving pentobarbital in water (T. L. Cunliffe-Beamer, unpublished observations). Green (1979)

Table II
Effect of Strain, Age, and Sex on Barbiturate Sleeptimes of Mice

Barbiturate	Dose (route)	Strain	Age	Sex	Mean sleeptime (min)	Reference
Pentobarbital	50 mg/kg (ip)	Swiss, Webster	9-12 months	♂	54, 70 ^a	Westfall <i>et al.</i> (1964)
		Swiss, Webster	9-12 months	♂ + DES ^b	32	
		Swiss, Webster	9-12 months	♀	21, 25	
		Swiss, Webster	9-12 months	♀ + TES ^b	42	
Hexobarbital	125 mg/kg (ip)	AL/N	Mature	♂	86, 99	Vesell (1968)
		AL/N	Mature	♀	58	
		BALB/cAnN	Mature	♂	46	
		C3H/HeN	Mature	♂	41	
		C57BL/6N	Mature	♂	73	
		CFW/N	Mature	♂	40, 29	
		CFW/N	Mature	♀	31	
		DBA/2N	Mature	♂	85	
		NBL/N	Mature	♂	73	
		NBL/N	Mature	♀	35	
		STR/N	Mature	♂	47	
		CAF ₁	Mature	♂	72	
		CDF ₁	Mature	♂	58	
		GP	Mature	♂	42, 34	
	GP	Mature	♀	31		
	100 mg/kg (ip)	NIH	Mature	♂	37	Catz and Yaffe (1967)
		C57BL ^c	90-120 days	♂	19	
		C57BL	90-120 days	♀ estrus	5	
		C57BL	90-120 days	♀ diestrus	10	
		BALB/cJ	90-120 days	♂	34	
		129/J	90-120 days	♂	62	
		BALB/cJ	newborn	♂	lethal	
		BALB/cJ	2 week	♂	36	
BALB/cJ		3 week	♂	9		
50 mg/kg (sc)	BALB/cJ	4 week	♂	16		
	BALB/cJ	5 week	♂	25 ^d		
	BALB/cJ	1 day	♂	45 ^d		
	BALB/cJ	1 week	♂	25 ^d		
	BALB/cJ	2 week	♂	18 ^d		
	129/J	1 day	♂	>400 ^d		
	129/J	1 week	♂	58 ^d		
	129/J	2 week	♂	22 ^d		

^a Means from two experiments.

^b DES, diethylstilbesterol; TES, testosterone.

^c Mice from The Jackson Laboratory, substrain not specified.

^d Mean estimated from bar graph.

recommended that pentobarbital solutions be prepared fresh and not stored for prolonged periods.

Effects of barbiturates on circulation, respiration, and hepatic and renal function are discussed by Price (1971). Uptake and distribution of radioactive labeled pentobarbital injected intravenously into mice has been described by Saubermann *et al.* (1974). Bell *et al.* (1971) reported that pentobarbital inhibited gonadotropin-induced ovulation in immature mice. Keratitis following administration of pentobarbital was observed

by Kaplun and Barishak (1976). However, they concluded that the keratitis resulted from corneal dehydration and trauma during anesthesia rather than direct action of the pentobarbital.

4. Tribromoethanol Solution

This drug is the anesthetic of choice for many procedures at The Jackson Laboratory. The ingredients, 2,2,2-tribromoetha-

nol and amylene hydrate (*T*-amyl alcohol) can be obtained from chemical supply companies, e.g., Aldrich Chemical Company, Milwaukee, Wisconsin. A concentrated 66 $\frac{2}{3}$ % tribromoethanol solution is prepared by mixing 2 parts tribromoethanol in 1 part amylene hydrate on a weight basis. This proportion can be obtained by mixing 25 g tribromoethanol in 15.5 ml amylene hydrate (Amylene hydrate weighs less than 1 g/ml.). Preparation of this stock solution can be facilitated by immersing the container in warm (less than 40°C) water. Prior to use, the concentrated tribromoethanol solution is diluted 1:80 to make a dilution containing a 1.25% stock solution (Jones and Krohn, 1960). Concentrated and dilute solutions should be kept in brown bottles wrapped with aluminum foil or heavy tape and stored in a cool place (less than 40°C). Tribromoethanol solution decomposes in the presence of excessive light and high (over 40°C) temperature. The pH of the solution indicates decomposition. If pH is below 5, the solution is decomposed to dibromoacetic aldehyde and hydrobromic acid and should be discarded (Lumb, 1963). In the author's experience, concentrated solutions are stable for several months, but diluted solutions decompose in 2–3 weeks.

The usual dose of tribromoethanol solution (used at The Jackson Laboratory) is 0.2 ml of the 1.25% solution/10 g body weight (160 mg tribromoethanol/kg) injected intraperitoneally (Jones and Krohn, 1960). Anesthesia occurs within 2–5 min, and surgical anesthesia lasts for 15–20 min. Mice completely recover in 1–2 hr. Reactions of mice less than 14–16 days of age or of adult homozygous diabetic (*db/db*) or obese (*ob/ob*) mice to tribromoethanol solution are not predictable. Other recommended doses include 120 mg/kg intravenously (Barnes and Eltherington, 1964), or 125 mg/kg (Green, 1979), 250 mg/kg (Barnes and Eltherington, 1964) and 370 mg/kg intraperitoneally (Tarin and Sturdee, 1972). In the latter study (Tarin and Sturdee, 1972) 35% of the mice died within 3 months due to intestinal ileus following unspecified surgical procedures and tribromoethanol anesthesia. Ileus was attributed to delayed toxicity of the tribromoethanol solution. Similar problems have not been observed when the lower dosage is used (Jackson Laboratory, unpublished observations).

Tribromoethanol anesthesia reduces blood pressure and respiratory rate. Delayed toxic effects due to renal and hepatic damage have been reported following high doses (Lumb, 1963).

F. Neuroleptanalgesics

Neuroleptanalgesia combines the administration of an analgesic and a tranquilizer or hypotic agent to induce central nervous system depression that borders on general anesthesia. Physiological effects of neuroleptanalgesic agents have been summarized by Green *et al.* (1981a,b) and C. J. Green (1975).

1. Fentanyl Alone and in Combination with Other Drugs

Fentanyl alone produces morphine-like effects in mice, i.e., tremors and exaggerated response to noise (Green *et al.*, 1981b). Lewis and Jennings (1972) reported that doses of 0.002 or 0.005 ml/g intramuscularly of a fentanyl–droperidol combination (10% solution of Innovar-Vet, Pittman-Moore) produces satisfactory anesthesia for skin grafting or splenectomizing mice, respectively. Walden (1978) also reported good results using fentanyl–droperidol as a sedative. Higher doses (0.004–0.006 ml/g) are required to anesthetize inbred mice for skin grafting and the mice remained sensitive to noise (T. L. Cunliffe-Beamer, unpublished observation). C. J. Green (1975, 1979) reported that fentanyl–fluanisone produced hyperesthesia in mice. However, fentanyl–fluanisone subcutaneously or intraperitoneally combined with diazepam, 5 mg/kg intraperitoneally, produced satisfactory surgical anesthesia for 60 min (C. J. Green, 1975). Green *et al.* (1981b) recently reported that a combination of 60 mg/kg metomidate and 0.06 mg/kg fentanyl injected subcutaneously produced surgical anesthesia for about 60 min. Intraperitoneal injection of different ratios of the metomidate–fentanyl combination did not produce reliable anesthesia or was lethal. They also tested a combination of 18 mg/kg etomidate:0.08 mg/kg fentanyl and found it was ineffective when administered subcutaneously and produced only 20–25 min anesthesia when administered intraperitoneally. Metomidate (50 mg/kg) or etomidate (24 or 30 mg/kg) administered intraperitoneally without fentanyl produced surgical anesthesia of relatively short duration (10–15 min) (Gomwalk and Nealing, 1981; Green *et al.*, 1981b).

2. Ketamine Alone and in Combination with Other Drugs

Ketamine alone, 44 mg/kg intramuscularly, was reported by Weisbroth and Fudens (1972) to produce 10–15 min surgical anesthesia after a 8–10 min induction period. C. J. Green (1975, 1979) and Green *et al.* (1981a) state that ketamine produced sedation but not analgesia even at doses approaching 200–300 mg/kg. McCarthy *et al.* (1965) and Chen *et al.* (1966) reported varying results (restlessness, ataxia, stimulation, or anesthesia) following intraperitoneal administration of ketamine. The results appear to be dose dependent. Since none of the authors indicated the age, sex, or strain of the mice tested, one must conclude that there is wide disparity among responses of mice to ketamine.

Mulder (1978) anesthetized mice using a ketamine hydrochloride and promazine combination (Ketaset Plus, Bristol Laboratories) given at 100 mg/kg (by ketamine content) intramuscularly. He concluded this combination with an effective anesthetic for mice. Mulder and Mulder (1979) reported a combination of 50 mg/kg ketamine and 50 mg/kg xylazine

given intramuscularly produced satisfactory anesthesia of variable length. In contrast, Green *et al.* (1981a) reported that 80 mg/kg ketamine and 16 mg/kg xylazine injected intraperitoneally produced excellent sedation and relaxation but insufficient analgesia to permit surgery. They also indicated that a ketamine-diazepam combination was not an effective neuroleptanalgesic for mice.

VII. SURGICAL PROCEDURES

A. Basic Techniques

Many surgical procedures developed for rats, cats, or dogs can be adapted for mice using microsurgery, ophthalmologic or watchmaker's instruments, and ophthalmologic suture. A binocular dissecting microscope with good depth of field, at least a 5-inch working distance, and uniform illumination is necessary for certain procedures, e.g., hypophysectomy. Microscopes designed for industrial quality control examinations usually lack the depth of field and working distance necessary for surgical procedures.

A basic surgical pack for abdominal surgery in mice should include the following.

1. A pair of microdissecting thumb forceps and a pair of sharp-sharp microdissecting scissors that are used to incise the skin.
2. A pair of microdissecting thumb forceps and a pair of sharp-sharp or blunt-sharp microdissecting scissors that are used to incise subcutaneous tissues and the abdominal wall.
3. One or two pairs of microdissecting thumb forceps, one or two pair of curved or straight watchmaker's forceps and a pair of iris or cataract scissors for manipulation and incision of abdominal viscera.
4. Small pieces of Gelfoam (absorbent surgical sponge) or

flat bladed toothpicks wrapped with surgical cotton to control hemorrhage (Fig. 10).

5. Size 4-O to 6-O suture for ligation of vessels and closure of abdominal and skin incisions. Alternatively, wound clips may be used to suture the skin. If nonabsorbable sutures, e.g., silk or cotton, are used to ligate blood vessels or suture the abdominal wall, aseptic technique must be observed in order to prevent suture granulomas. Ophthalmologic sutures with pre-attached needles save time and reduce tissue trauma.

6. Baby Derf, Castroviejo, or Noyes needle holder.

7. Paper clip retractors or eyelid retractors for retraction of abdominal walls or viscera (Fig. 10).

8. Surgical drapes made from autoclavable plastic bags, disposable drapes designed for human or veterinary use, or cotton cloth. Drapes are optional during short procedures, such as castration, but are recommended for prolonged procedures that require exteriorization of the viscera or those procedures being performed on immune-suppressed mice.

Surgical instruments are steam sterilized (15 lb, 250°F, 15 min). Delicate points of scissors or watchmaker's forceps should be protected by small pieces of autoclavable rubber tubing. If ethylene oxide sterilization is used, the pack should stand for a few days to be certain residual ethylene oxide has dissipated. If chemical sterilization is germicides, e.g., alcohol or Zephiran Chloride, are used, instruments should be physically clean before soaking for at least 15 min and should be rinsed in sterile saline or water before use to minimize irritation of tissues by residual germicide. Germicidal solutions should be replaced frequently to prevent bacterial contamination. Long-term storage of instruments in germicidal solutions should be avoided in order to prevent rusting or damage to cutting surfaces. Dry heat (350°F, 1 hr) can also be used to sterilize surgical packs. After surgery, delicate instruments should be cleaned with a toothbrush, mild soap, and warm water.

Mouse surgery does not require cap, mask, gown and an

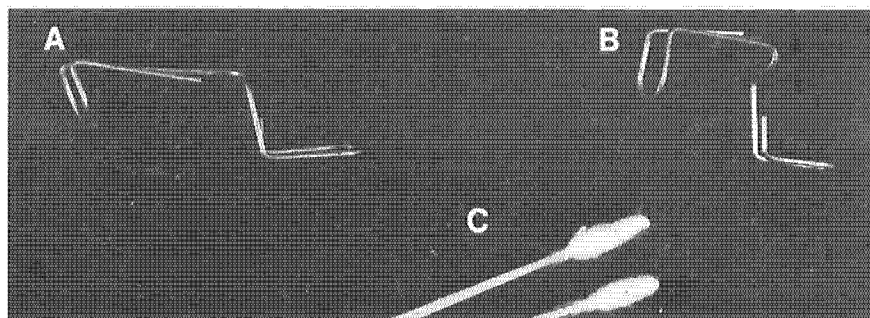

Fig. 10. Paper clip retractors and toothpick swabs. (A) Acute angle paper clip retractors for retraction of abdominal muscles. (B) Right angle paper clip retractor for retraction of abdominal viscera. (C) Toothpick swabs used for direct pressure hemostasis.

operating suite, but unsterile instruments, failure to decontaminate skin, and barehanded handling of viscera are unacceptable. Tissues should be handled with the tips of sterile instruments, using a "no touch" technique. This means that mouse's tissues are handled with the tips of sterile instruments only and that the surgeon picks up instruments by the handles only and does not touch the tips. If it is necessary to handle internal organs by hand, sterile surgical gloves are mandatory. Experimental results should not be compromised by preventable postsurgical bacterial infections. In the author's experience, the procedures outlined below when combined with improved presurgical decontamination of skin and elimination of silk ligatures increased the rate of successful ovarian transplants in Jackson Laboratory Animal Resources mutant production colonies from approximately 25% to 65–70%.

1. Assign surgical instruments to a particular task, e.g., skin incisions, and use them only for the specific task.

2. Arrange instruments on a sterile surface, in order to use, with handles pointing in the same direction.

3. Cover the tips of instruments with a piece of sterile drape when they are not in use.

4. Between each surgical procedure, remove blood from tips of instruments using 70% alcohol and a sterile gauze sponge or cotton ball. Whenever possible, change instrument packs between cages of mice.

5. Use a no-touch technique. Do not touch viscera or tips of sterile instruments with ungloved hands.

Regardless of the surgical procedure to be undertaken, hair around the incision site is removed and the skin decontaminated with swabs soaked in 70% alcohol, mild tincture of iodine, or benzalkonium chloride. Decontamination of the skin begins at the incision site and extends in widening circles. Plucking the hair may leave a few hairs shafts attached to the skin; but, clippers often nick the skin and leave small pieces of loose hair that are difficult to remove and tend to migrate into abdominal incisions. Depilatories may be used to denude large areas of skin. The mouse is anesthetized 1–2 days prior to surgery and the depilatory is applied according to the manufacturer's instructions; then the depilatory is rinsed off and the mouse's skin is dried. Use of depilatories increases technician time and causes additional stress to the mouse, but large areas of skin can be denuded using this method.

Mouse skin and abdominal muscles are thin and fragile compared to other species and cut edges tend to curl under during the suturing process. In the author's experience interrupted horizontal mattress sutures or simple interrupted sutures are preferred suture patterns for mouse skin or abdominal muscles because they minimize inversion of the skin or peritoneal edges. Optimal healing of skin and abdominal wall requires contact between each dermal surface of the skin or peritoneal surface of the abdominal wall and separate closure of the incisions in the

skin and abdominal muscles. Small (1–3 mm) incisions in the dorsal abdominal wall near the lumbar muscles need not be sutured provided the skin incision is not directly over the incision in the abdominal wall. If wound clips are used, care must be taken to evert, not invert, the edges of the skin.

To aid the reader to visualize descriptions of surgical procedures, the following pairs of definitions have been included:

1. Dorsal—located near the back of the mouse; ventral—located near the belly.

2. Medial—located near the central axis of the mouse's body; lateral—located away from the central axis, toward the side.

3. Cranial—located toward the head; caudal—located toward the tail.

4. Distal—located away from the center of the body; proximal—located closer to the center of the body.

For further clarification of anatomical details, Cook's drawings of anatomical dissections should be consulted (Cook, 1965; Cook, Chapter 7, this volume).

B. Adrenalectomy

The adrenal glands are located on either side of the midline near the kidneys. Accessory adrenal nodules may be located along the vena cava or renal vessels. The number and exact location of accessory adrenal modules varies with strain, age, and sex (Coupland, 1960; Hummel, 1958). Adrenalectomy of female mice can be expected to obliterate cyclic leukocyte fluctuations associated with estrus and alter relative distributions of different leukocytes in both male and female mice (Chapman, 1968).

The adrenalectomy procedure for rats described by Grollman (1941) or Llauro (1958) utilizing a single dorsal midlumbar skin incision and bilateral lateral incisions through the abdominal muscles cranial to the kidneys can be adapted to mice. The adrenals are exteriorized, one at a time, by grasping the periadrenal fat and mesenteric attachment. The adrenal glands are excised after the blood vessels are occluded and torn using watchmakers or thumb forceps. If necessary, incisions in the abdominal muscles are closed with a single suture. The skin incision is closed with a wound clip or interrupted sutures. This procedure minimizes manipulation of abdominal viscera; but, does not permit visualization of accessory adrenal nodules.

An alternative adrenalectomy procedure utilizes a midventral abdominal skin incision through the line alba and lateral retraction of the intestines to expose the kidneys and associated adrenals. Adrenal vessels are torn or ligated with 5-0 suture. The abdominal approach requires more time, but accessory adrenal nodules can be easily observed and excised.

C. Artificial Insemination

Lightly etherized or unanesthetized restrained estrous female mice can be inseminated using a transcervical approach (Snell *et al.*, 1944; Southard *et al.*, 1965; West *et al.*, 1977). Laparotomy and insemination directly into uterine horns has also been reported (Wolfe, 1967). Sperm numbers markedly influence conception rate and litter size (Takeshima and Toyoda, 1977). Higher conception rates have been observed in females inseminated between 9:00 PM to 12:00 midnight, near the time that mating would usually occur (Ino, 1961). After insemination, the female mouse is mated to a vasectomized male or the vagina is dilated with a cotton plug in order to simulate mating (Leckie *et al.*, 1973; West *et al.*, 1977). Certain anesthetics, such as barbiturates, inhibit ovulation (Bell *et al.*, 1971) and may, therefore, cause marked reduction in conception rates.

D. Embryos and Embryo Transplants

Two- to eight-cell embryos can be collected using techniques similar to those for ova collation (Section IV.I). Morulae (60 hr after fertilization) have migrated into the uterus; therefore, uterine horns and oviduct must be excised and flushed if morulae or blastocysts are to be recovered (Snell and Stevens, 1975). Preimplantation embryos can be transplanted into pseudopregnant female mice by transcervical inoculation (Beatty, 1951; Corbeil *et al.*, 1978; Marsk and Larrson, 1974; Moler *et al.*, 1979) or by laparotomy and intrauterine inoculation (Fekete and Little, 1942). Pseudopregnant female mice are prepared by mating estrous females to a vasectomized male 2–3 days prior to embryo transplant. The use of the "pregnant empty uterus" (ligated utero-oviduct junction) has been advocated by Checiu *et al.* (1977), but results obtained using this type of recipient do not appear to compensate for the increased preparation time.

Transcervical inoculation of embryos or sperm is faster than intrauterine inoculation, and does not require anesthesia unless the procedure is performed on wild mice. Cervical adhesions resulting from cervical trauma at the time of insemination or embryo transfer occasionally causes dystocia. Intrauterine inoculation during laparotomy eliminates cervical trauma and assures intrauterine placement of sperm or embryos; however, anesthesia, surgical instruments, and increased time per female mouse are required.

E. Hepatectomy

The mouse's liver is divided into four main lobes, left lateral, right lateral, median, and caudal, each being joined dorsally. The right lateral, median, and caudal lobes may be

further subdivided depending upon sex and strain (Rauch, 1952). The gall bladder is located within a deep bifurcation of the median lobe (Hummel *et al.*, 1975). In partial hepatectomy, a ventral midline skin and abdominal incision is made (Feigelson *et al.*, 1958). The ventral hepatic mesentery is severed and then the left lateral, left median, and right median lobes are ligated separately, taking care to preserve the gall bladder and biliary ducts. Ligating these lobes of the liver with a single ligature results in a high mortality rate, presumably due to disruption of the bile ducts. Liver biopsies can be obtained by ligating either the left lateral lobe or the largest of the right lateral lobes with 4-0 absorbable suture and excising a piece of liver distal to the ligature. Hemorrhage is controlled by pressing a small piece of Gelfoam (absorbable surgical sponge) against the cut surface.

F. Hypophysectomy

The pituitary (hypophysis) of the mouse rests on the dorsal surface of the basisphenoid bone. The transbuccal and trans-temporal approaches for hypophysectomy of other species (Markowitz *et al.*, 1964) are not adaptable to rats or mice because of lack of space inside the oral cavity, high mortality, and variable results (Smith, 1930). In transauricular hypophysectomy of mice and rats, a modified hypodermic needle is inserted through the auditory canal into the osseous bulla (Falconi and Rossi, 1964). The medial wall of the osseous bulla is perforated near the occipital sphenoidal suture and the pituitary gland is aspirated using a water suction pump. Transauricular hypophysectomy is fast; but direct observation of the pituitary gland is impossible, and laceration of nerves and blood vessels in close proximity to the pituitary is probable.

Parapharyngeal hypophysectomy of mice is the preferred approach and has been described, in detail by Lostroh and Jordan (1955), Nakanishi and Nagasawa (1976), and Thomas (1938). Parapharyngeal hypophysectomy of rats as described by Ingle and Griffith (1949) or Smith (1930) is also adaptable to mice. In general, drilling a circular hole into the occipitosphenoidal synchondrosis (Nakanishi and Nagasawa, 1976) to expose the pituitary gland is more successful than splitting the synchondrosis (Thomas, 1938). Key points to successful hypophysectomy of mice, especially very young (15 days of age) and old mice (over 12 months) include: (1) careful retraction of the salivary glands to avoid subcutaneous leakage of saliva, (2) tracheotomy between the fourth and fifth tracheal rings, (3) adjusting the size of the dental burr to correspond to the size of the mouse, and (4) attentive postoperative care (Beamer, 1981). Posthypophysectomy care should include 0.5–1.0 ml intraperitoneal or subcutaneous fluids (e.g., physiological saline) once or twice daily for 2 days, a warm (75°–80°F) dry environment, wet mash diet for 2–3 days, and 10 µg cortisol

acetate (Beamer, 1981) or 0.25 mg hydrocortisone acetate (Nakanishi and Nagasawa, 1976) immediately postsurgery and 24 hr later. Gastric intubation to administer fluids should be avoided in order to minimize further trauma to parapharyngeal tissues. Strain differences in recovery after hypophysectomy should be expected.

G. Hysterectomy and Hysterotomy

The uterus of mice consists of two relatively long lateral horns and a short body. Hysterectomy (excision of the uterus) or hysterotomy (caesarian section) are usually performed to obtain fetuses for research or to eliminate microorganisms that are unable to cross the placental barrier. If hysterectomies are performed to obtain germfree mice, strict attention to aseptic technique is mandatory, and culture of the uterus and placenta is indicated. At the Jackson Laboratory, *Pasteurella pneumotropica*, *Proteus* spp., or *Mycoplasma pulmonis* have been occasionally isolated from uteri that contained viable term fetuses. The microbiologists performing uterine cultures should be notified if the uterus has been exposed to disinfectants.

To obtain viable fetuses, surgery must be performed on the expected day of parturition, and fetuses must be resuscitated within 10–15 min. Foster mothers (multiparous females, if available) should have delivered their litters 1–4 days prior to the expected delivery date of hysterectomy candidates. The Whitten effect (see W. Beamer, this volume, Chapter 10) can be used to synchronize estrus in groups of potential foster mothers or hysterectomy candidates. Hysterectomy should be scheduled for 18½ to 20 depending upon the strain. Trial and error at The Jackson Laboratory has helped in developing the following “rules of thumb” regarding hysterectomy: C57BL mice are usually scheduled for late afternoon of day 18 or morning of day 19; BALB/c and C3H mice are scheduled for middle of day 19; and A/J mice are scheduled for afternoon of day 19 or morning of day 20 (the day the seminal plug is observed being day 0). Parturition can be delayed by subcutaneous injection of progesterone in oil (0.05–0.1 ml, 25 mg/ml) during the last 2 or 3 days of gestation. However, in some strains, administration of progesterone appears to increase the number of stillbirths. Prolongation of gestation for more than a few hours also appears to markedly increase the number of stillborn mice. Administration of progesterone should not be used as a substitute for monitoring fetal development by palpation.

In the author's experience, known breeding dates combined with knowledge of the usual gestation period for a specific strain maximizes the chance of obtaining viable fetuses. Lactation delays implantation for variable lengths of time; therefore, nursing females are not good hysterectomy or foster mother

candidates unless one is very skilled at estimating fetal development using abdominal palpation and other signs. The head of a term fetus feels distinct, firm, and round; the body of a term fetus feels elongated, and the rump is palpable. Movement of term fetuses and descent of pups into the pelvic inlet can be observed by restraining the pregnant female as if an intraperitoneal injection is being made. Fetal movement and descent indicate parturition within 12 hr. Vulvar relaxation, a slight mucous vaginal discharge, prominent nipples, and distended mammae indicate parturition within 12 to 36 hr.

Hysterectomy and resuscitation of newborn are described in the following paragraphs. The gravid female is killed by cervical dislocation, dipped in disinfectant, and placed in dorsal recumbancy on a cork board. A paramedian skin incision is made from the pelvis to the thoracic inlet using sterile forceps and scissors, taking care not to puncture the muscle layers. The skin is dissected away from the muscles and reflected laterally; the incision is extended along the legs. The instruments used for cutting the skin are discarded, and the skin is pinned to the cork board. A sterile drape with a 1–2 inch slit in the center is placed over the abdomen with the slit on the midline and parallel to the vertebral column. A second set of instruments is used to incise the linea alba, taking care not to puncture the uterus or the intestinal tract. Sterile forceps are used to clamp the drape to the abdominal wall. To reduce the possibility of uterine rupture, the uterus is grasped between fetuses with dissecting forceps and gently pulled through the abdominal incision, or scooped from the abdomen using the broad end of a scalpel handle. The ovarian and uterine attachments are torn using two pair of forceps and the uterus is rolled toward the tail. The uterus is ligated cranial to the cervix and the body of the uterus is severed between the ligature and the cervix. The pregnant uterus is placed in a dry sterile container or a dip tank containing warm disinfectant.

Fetal resuscitation is performed under a lamp with a 75-W bulb or on a warm surface in order to prevent chilling of the neonates. The gravid uterus is carefully incised on the antimesenteric side. The fetuses and placenta are separated from the uterus using gauze sponges, swabs, and forceps. The umbilical cords are left attached to the pups until the blood empties from the cord. The pups are gently rolled and massaged with sponges or swabs until they are pink in color and breathing normally. Pinching the tail with forceps and extending the head stimulate respiration. The foster mother is removed from her cage while all or part of her litter is removed, and the hysterectomy-derived litter is placed in her nest. If the hysterectomy-derived litter contains only a few pups, two to four of the foster mother's litter are identified by toe or tail clips or future coat color and left in the cage to assure adequate suckling to maintain lactation. Ether or cheap cologne can be placed on the dam and litter to mask human scent, but minimal handling and wearing plastic gloves are preferable.

If the pregnant female mouse is too valuable to kill, the author has performed hysterotomies using modifications of the technique for canine hysterotomy described by Smith (1965). The timed pregnant female mice are anesthetized using methoxyflurane and prepared for abdominal surgery including draping the abdomen prior to incising the skin. A ventral midline skin incision is made from pubic symphysis to xyphoid cartilage. A second pair of forceps and scissors are used to incise the linea alba, and the gravid uterus is gently elevated from the abdominal cavity as described above. One or two incisions are made in the antimesenteric side of each uterine horn. Fetuses are delivered through these incisions using gentle manipulation of the uterine walls. Uterine incisions are sutured with 6-0 to 9-0 absorbable suture in an inverting continuous horizontal mattress suture (Cushing's pattern). The linea alba and skin incisions are sutured with 5-0 suture using an interrupted pattern. Fetal viability is poor, probably as a result of respiratory depression due to methoxyflurane; however, the valuable dams recover uneventfully.

H. Isolated Intestinal Loops

The ligated mouse intestinal loop was first developed as an *in vivo* assay for enterotoxins (Punyashthiti and Finkelstein, 1971; Schiff *et al.*, 1974). However, this procedure can be adapted for acute radioisotope absorption studies (Beamer, 1981). The mouse is fasted for 8 to 14 hr and anesthetized. The abdominal viscera are exposed through a ventral midline incision; the duodenum and jejunum are then exteriorized. Beginning 8 cm from the pyloric sphincter, two 6-cm loops, separated by a 1-cm interloop, are formed by ligating the intestine with 5-0 silk sutures. To assure viable intestinal mucosa, ligatures must not occlude the mesenteric blood vessels. Test substances are then injected into the loops.

I. Lymphnodectomy

Location and drainage areas of visceral and superficial lymph nodes are described by Kawashima *et al.* (1964). Excision of the axillary nodes of mice is described by Ciccirelli *et al.* (1979), and Sakita *et al.* (1979) described regional lymphnodectomy. To excise superficial lymph nodes, such as, axillary, popliteal, external sacral, superficial cervical, medial and lateral mandibular, a transverse skin incision is made over the lymph node(s) and the node(s) is exposed by blunt dissection. Many visceral lymph nodes are closely associated with major blood vessels, such as the portal vein, vena cava, or aorta. Excision of visceral lymph nodes requires laparotomy (or thoracotomy) and careful dissection in order to separate the lymph node from associated blood vessels.

J. Mammary Gland Excision and Transplant

Female mice usually have five pairs of mammae, three on the thorax and two on the abdomen, extending laterally along the flank, neck, and scapular muscles (Hummel *et al.*, 1975). Excision of all mammary tissue requires extensive careful dissection of skin and subcutaneous tissues. Dux (1962) presents a detailed description of total mastectomy in 19- to 23-day-old mice. Fekete (1939) undertook total mastectomy in 10-day-old mice; mortality was high and ablation of the caudal pairs of mammae was difficult. Partial mastectomy of 3-week-old mice and transplantation of hyperplastic mammary nodules or normal mammary tissue into the resulting gland-free fat pad have been described in detail by DeOme *et al.* (1959) and the staff of the Cancer Research Genetics Laboratory, University of California (1963). Transplantation of whole mammary glands was described by Thompson (1963).

K. Miscellaneous Transplant Techniques

Endocrine glands can be transplanted to a variety of sites; subcutaneous, intraocular, intraperitoneal, or under the capsules of the spleen, kidney, or testicle. Selection of the recipient site markedly influences apparent or real function of the transplanted tissue. Subcutaneous thymic implants grow slower and show greater thymocyte depletion than thymic implants placed under the kidney capsule (O'Gara and Ards, 1961). Hormones excreted by transplants placed under the kidney capsule directly enter the systemic circulation. Hormones excreted by transplants placed under the splenic capsule enter the hepatic portal system where they are metabolized by the liver before entering the system circulation (Krohn, 1963).

Subcutaneous transplant sites include the axilla (Miller, 1960), middorsal or midventral abdomen (Faulkin and DeOme, 1958), between the scapulae (Varnum, 1981), or ear (Muranyi-Kovacs *et al.*, 1977). Small pieces of tissue can be transplanted under the capsule of the spleen (O'Gara and Ards, 1961) or the kidney (Talmage and Dart, 1978). The spleen or kidney are exposed using the same technique described for splenectomy or nephrectomy. A small nick is made in the capsule with sharp scissors, and the transplant is inserted through the nick and pushed under the capsule using a 18-gauge trocar or 1-mm round-tipped glass rod. The transplant is inserted into the side of the spleen or kidney opposite the blood vessels to prevent accidental laceration of the vessels. Hemorrhage resulting from accidental laceration of the splenic or renal parenchyma can be controlled by direct pressure. A similar technique has been used to transplant fetal genital ridges under the capsule of the testicle (Stevens, 1964).

A technique for ovarian graft into the anterior chamber of the eye is described by Talamantes *et al.* (1977). Small pieces of

tissue can also be injected intraperitoneally where they subsequently implant on the abdominal wall (Dickerman *et al.*, 1979b).

Organs can be transplanted if blood supply is preserved. Corry *et al.* (1973) described an intraabdominal cardiac transplant. A technique for excision of the middle third of the tibia and intramedullary pinning of a replacement graft with a 25- to 27-gauge needle was described by Halloran *et al.* (1979).

L. Nephrectomy and Kidney Transplant

The right kidney is usually larger and more cranially located than the left kidney (Hummel *et al.*, 1975). The relatively caudal location of the left kidney makes it more accessible to excision through a flank approach. A skin incision is placed parallel to the last rib beginning midway between the last rib and the iliac crest. The kidney is observed through the transparent abdominal wall, and the abdominal wall is incised over the kidney between segmental vessels. The kidney is bluntly dissected free of the renal fat pad and adrenal gland. A small piece of posterior perirenal fat is left attached to the kidney and serves as a handle. This handle reduces the possibility of accidental puncture of the kidney or renal vessels during dissection. The renal vessels are ligated with a single 4-0 to 5-0 ligature and severed. The ureter is either crushed and torn or ligated, and the kidney is withdrawn through the incision. The incisions in the abdominal wall and skin are sutured separately. This technique was initially described by Ingle and Griffith (1949) for the rat. It does not, however, permit examination of both kidneys at the same time. This can be a disadvantage if one is using strains of mice with a high incidence of hydronephrosis.

An alternative approach exposes both kidneys through midline ventral skin and linea alba incision. The abdominal wall is retracted using eyelid retractors or paper clip retractors (Fig. 10). The colon is picked up and retracted toward the right side of the abdomen in order to expose the left kidney. The small intestine jejunum is picked up and retracted toward the left side of the abdomen in order to expose the right kidney. The desired kidney is dissected free, and its vessels are ligated as described above. If desired, the left kidney and associated vessels can be prepared for transplantation (Skoskiewicz *et al.*, 1973). The transplant procedure relocates the left kidney distally and reestablishes circulation using aortic and vena caval patch grafts. The ureter is reattached using a bladder patch graft.

M. Olfactory Bulb Ablation

The paired olfactory bulbs are located within the cranial cavity anterior to the cerebral hemispheres (Cook, 1965). A

simple method for removal of the olfactory bulbs by suction is described in detail by Saito and Takahashi (1977). If olfactory nerve section is desired, the same surgical approach can be used and the olfactory nerves are served on the cranial side of the ethmoid plate using a hypodermic needle or microsurgery scalpel (Harding and Wright, 1979). Surgical procedures in the nasal area should be carefully executed in order to avoid obstruction of the nasal passages. Nasal obstruction results in aerophagia that causes changes in blood pressure, heart, and respiratory rates that may result in death. This syndrome can be avoided if tracheotomy is performed prior to nasal obstruction (Nakajima and Tsuchiya, 1974).

N. Orchidectomy, Testicular Biopsy

The inguinal canals of the male mouse remain open throughout life. Therefore, the testicles may be retracted into the abdominal cavity or extended into the scrotal sacs (Hummel *et al.*, 1975). The epididymal fat pad is well developed and occupies the inguinal canal when the testicles are in the scrotal sacs.

Orchidectomy is usually performed by a scrotal route through a single transverse incision across the end of the scrotum or through two anterior-posterior incisions parallel to the median raphe of the scrotum. The anesthetized mouse is restrained in a dorsal recumbant position. Elevating the mouse's head and body causes the testicles to descend into the scrotum. The testicles are gently withdrawn through the skin incision until the spermatic vessels and vas deferens are exposed. The spermatic vessels and vas deferens of young (3- to 5-week-old) male mice can be crushed, torn, released, and allowed to retract into the abdominal cavity. A single 4-0 or 5-0 ligature around the spermatic vessels and vas deferens of adult mice may be necessary to prevent excessive hemorrhage. The epididymal fat usually herniates through the incision and should be completely excised to prevent recurrent herniation. Occasionally, a seminal vesicle or loop of intestine herniates through the inguinal canal. These organs are returned to the abdomen using a combination of manual repulsion and tilting the mouse's head down. Recurrence of this type of hernia is rare. Small scrotal incisions usually do not need to be sutured.

Orchidectomy of neonatal male mice can be performed through a transverse midline incision between the umbilicus and pelvis (East and Parrott, 1962). This approach should be used to castrate adult male mice with permanently retained testicles and can be used to castrate normal adult male mice. However, the abdominal approach for castration of normal adult male mice requires more time because of manipulation of abdominal viscera and suturing of incisions.

A method for repeated testicular biopsy obtains tissue through hypodermic needles of various sizes (Martin and Richmond, 1972).

O. Ovariectomy, Ovarian Transplant, and Ovariohysterectomy

The ovaries, located near the posterolateral pole of the kidney, are enclosed in thin transparent capsules that lie on the ovarian fat pads and are attached to the dorsal body wall by the mesovarian (Hummel *et al.*, 1975). Ovariectomy can be performed through a dorsal longitudinal or a transverse midlumbar skin incision. The skin over the sides of the abdomen is undermined, allowing shifting of the incision laterally to the right or left side of the abdomen, in order to expose lumbar and abdominal muscles. A 3- to 5-mm incision is made in the abdominal muscles parallel to segmental blood vessels beginning 1 or 2 mm ventral to the lumbar muscles. The ovarian fat pad is exteriorized by grasping its ventral edge; the ovary is exposed by rotating the ovarian fat pad 90° toward the back. The fallopian tube and ovarian and capsule vessels are crushed and torn; the ovary is excised using two pairs of watchmaker's forceps. This procedure results in minimal blood loss if the pair of forceps holding the ovarian pedicle is held in place for a few minutes. After the fat pad is returned to the abdominal cavity, the incision in the abdominal wall is sutured to eliminate the possibility of postoperative herniation of uterus or intestine. The edges of the skin incision are opposed with sutures or wound clips. This is a modification of the rat surgical procedure described by Ingle and Griffith (1949). Small incisions in the abdominal wall near the lumbar muscles may be left unsutured with little risk of postoperative herniation.

Orthotopic ovarian transplant procedures have been described by Jones and Krohn (1960), Robertson (1942a,b), Russell and Hurst (1945), Stevens (1957), and Tanioka *et al.* (1973). The illustrations in the articles by Jones and Krohn (1960) and Tanioka *et al.* (1973) are especially helpful. The usual procedure utilized in the Jackson Laboratory's Animal Resources mutant production colonies is to transplant unilaterally one-half of an ovary into two hosts, thus one donor serves four hosts. The donor (3–5 weeks of age) is killed by cervical dislocation, and the ovaries are excised as described above. The recipient mouse (5–7 weeks of age) is anesthetized, and one ovary (usually the left) is exposed as previously described. At this point, a semicircular incision is made into the bursa opposite the oviduct with the edge of the incision including 1–2 mm of periovarian fat. The margin of periovarian fat serves as a handle for reflecting the capsule of the bursa away from the ovary toward the oviduct. The ovarian vessels are crushed and torn using fine pointed curved watchmaker's forceps. The points of the forceps must be directed perpendicular to the oviduct to avoid accidentally crushing the oviduct. After the recipient ovary is excised, one-half of a donor ovary is placed on top of the ovarian vessels that are compressed by the points of a pair of watchmaker's forceps. After the ovary is placed on top of the vessels, the forceps are gently released. If no bleeding is observed, the ovarian capsule

is returned to its normal position. Bleeding, if observed, is controlled by removing the ovary and applying direct pressure with the tip of a cotton-wrapped toothpick. The ovary and ovarian fat pad are then returned to the abdominal cavity, and the contralateral ovary is excised through an incision in the contralateral abdominal muscles. Mating systems should be designed so that offspring of the donor and recipient ovaries can be separated by coat color, because residual pieces of recipient ovary can hypertrophy and function normally.

Ovariohysterectomy is performed through a ventral midline abdominal incision extending from the umbilicus to slightly anterior to the pubic symphysis. One horn of the uterus is grasped with a pair of forceps and retracted into the incision to expose the ovary and utero-ovarian vessels. The ovary is excised as described above. In young mice these vessels can usually be crushed and torn with forceps with minimal blood loss. Ligatures may be required in the case of older adult, pregnant or estrus mice. The other uterine horn and ovary are exposed and the ovary is excised. The uterine mesentery is torn between the uterine vessels and the dorsal abdominal wall, and the uterine horns are rotated toward the tail; this exposes the uterine body and cervix. The uterine body and associated uterine vessels are ligated with a single suture just cranial to the cervix. Last, the uterine body and vessels are severed leaving the ligature attached to the uterine pedicle and cervix. The abdominal wall and skin incisions are sutured separately with 4-O or 5-O sutures.

P. Parabiosis

Parabiosis involves the surgical attachment of two animals with the objective of studying circulation of cells or humoral factors between the two animals. After anesthetizing the mice, the left side of one mouse and the right side of the other mouse are prepared for surgery. Longitudinal skin incisions beginning 0.5–1 cm from the base of the ear, extending across the side of the neck, dorsal half of the shoulder, thorax, and abdomen and terminating near the base of the tail are made in the left side of one mouse and right side of the other mouse. Ventral skin edges are sutured together beginning in the center of the incision (Bunster and Meyer, 1933; Finerty, 1952). Next, the cranial and caudal corners of the skin incisions are sutured, and last the dorsal skin edges are sutured. This procedure involves careful dorsal–ventral rotation of the pair of mice (Montgomery, 1975). Careful placement of the skin incisions is critical to the successful adaptation of the mice to parabiotic life. If the parabiotic union stops at the shoulders, the mice tend to tear the ends of the incisions as they struggle to walk in opposite directions. Extending the incision to the base of the ear (T. L. Cunliffe-Beamer, unpublished observation), or suturing the scapulae together with stainless suture (Ebbe *et al.*, 1978), or excising the part of the scapular muscles and spine of the

scapula in order to achieve a bony union of the scapulae (Montgomery, 1975) prevents this problem. Ebbe *et al.* (1978) also recommend suturing the femurs together in order to increase the physical strength of the parabiotic union.

Variations of this procedure include suturing the intact abdominal walls together or incising the abdominal walls and performing a coelioanastomosis (Benson and Abelseth, 1975; Pope and Murphy, 1960). Coelioanastomosis permits exchange of extravascular fluids between the mice, but herniation and torsions of the intestines causing death are occasionally observed. The risk of herniation is minimized if the incisions in the abdominal wall are placed in the dorsal half or third of the abdomen (T. L. Cunliffe-Beamer, unpublished observation).

In the author's experiences with parabiosis of small mutant and normal mice, fewer postsurgical feeding problems or fights are observed if the heads are positioned nearly opposite each other. Parabiosis has also been adapted to study cross innervation between muscles of dystrophic and normal mice (Douglas, 1972; Montgomery, 1975).

Q. Parathyroidectomy

The location of parathyroid glands in mice varies from the dorsolateral border of the thyroids to the thymic septa; the number of glands also vary (Hummel *et al.*, 1975). Parathyroid glands are not easily distinguished from surrounding tissue except in strains where melanoblasts are found in the parathyroid glands (Dunn, 1949b). For these reasons, surgical ablation of all parathyroid tissue is difficult, if not impossible. Partial parathyroidectomy can be achieved by excising the thyroid glands and surrounding tissue.

R. Pinealectomy

The pineal gland is a small body located on the dorsal surface of the brain, between the cerebrum and cerebellum, almost directly under the suture between the parietal and interparietal bones (Hummel *et al.*, 1975). The technique described by Andersen and Wolfe (1934) for pinealectomy of young rats can be adapted for mice. Hata and Kita (1978) described in detail an alternative technique for pinealectomy of mice. In either case, hemorrhage must be controlled with light pressure and penetration of the transverse or longitudinal sinuses must be avoided.

S. Skin Grafts

Billingham (1954) discussed general techniques of mouse skin grafting, indices of healing, and common pitfalls. Skin

grafting procedures can be divided into two groups: (1) free skin grafts to the dorsal or lateral thorax and (2) tail skin grafts. The biggest challenges in skin grafting mice are keeping the grafts in place and keeping the mice from mutilating the grafts. Billingham and Medawar (1951) and Bryant and Bernard (1955) recommended holding the graft in place with perpendicular pressure in the form of a petroleum jelly-soaked gauze covered with adhesive tape or a self-adhesive crepe rubber bandage. Conway and Stark (1954) covered their skin grafts with transparent mica chambers held in place with copper wire splints. Sedlacek *et al.* (1970) and Seibert and Pollard (1973) held their grafts in place with collodion and plastic bandages. Gottfried and Padnos (1959) and Gross *et al.* (1960) developed a technique using Wademar type skin punch, cellophane tape, surgical adhesive spray, and a vest. The cellophane tape technique has the advantage of preventing both the graft and the recipient site from changing shape. Silmsler *et al.* (1955) made a rigid chest bandage from an oblong plastic coverslip. Hardin (1954) sutured his skin grafts in place with 4-0 suture and covered them with collodion. All of the above individuals were grafting relatively large pieces of skin (1.0 to 1.5 cm²). Most of them recommended the dorsal thorax as a relatively immobile and inaccessible (to the mouse's teeth) site. Van Es (1972) described a technique for massive skin grafting in rats. Skin from 20–40% of the body surface was grafted. With minimal modification, this technique can be adapted to mice.

Silmsler *et al.* (1955) demonstrated that skin from the tail can be successfully transplanted to the body. Bailey and Usama (1960) described orthotopic tail skin grafting. In this procedure, full thickness pieces of tail skin are excised from the ventral or dorsal surfaces of the tail using a No. 10 scalpel blade. Hemorrhage, if observed, is controlled by direct pressure with cotton wrapped toothpicks or facial tissue. Skin grafts are pressed into the raw bed made by the previous excision and protected with a cover made from a piece of lightweight glass tubing. The glass tubing is held in place by a wound clip or masking tape wrapped in the shape of a butterfly. The tape was reported to cause fewer problems. Six to eight grafts can be placed on the dorsal or ventral surfaces of the tail. Jennings *et al.* (1972) manufactured a protective device for tail skin grafts from the cover of a 26-gauge 1/2-inch hypodermic needle. Regardless of the size of the skin graft, site of origin, or method of transplantation, the grafted skin should be rotated so that the hair regrowth will be in a different direction from the remainder of the hair coat. This method guarantees identification of long-term grafts between mice with similar coat colors.

T. Splenectomy

The spleen is located in the left side of the abdomen slightly caudal to the stomach (Hummel *et al.*, 1975). Splenectomy of

the mouse can be performed through 0.5- to 1-cm midventral skin and linea alba incisions extending from umbilicus toward the xiphoid cartilage or through 0.5- to 1-cm dorsoventral incisions in the skin and muscles of the upper left abdomen approximately 0.5 cm caudal to the last rib and parallel to segmental vessels. Using the latter approach, the spleen is observed through the transparent abdominal wall, and manipulation of abdominal viscera is minimized (Dickerman *et al.*, 1979a). The spleen is exteriorized by grasping the dorsal end with smooth-tipped thumb forceps and exerting gentle traction. The splenic blood vessels, located in the mesentery attached to the medial surface of the spleen, may be ligated with 5-0 sutures prior to transection with iris scissors (Cicciarelli *et al.*, 1979) or grasped with two pairs of fine thumb or mosquito forceps and crushed and torn one at a time by exerting traction on the forcep nearest the spleen. The proximal forcep is gently released after 10–15 sec. This procedure usually provides excellent hemostasis.

Next, the mesentery between groups of splenic blood vessels is bluntly dissected away from the spleen. After all mesenteric attachments and blood vessels are severed, the pedicle is returned to the abdominal cavity. If necessary, hemorrhage can be controlled by occluding individual blood vessels with a pair of forceps or a flat-bladed toothpick wrapped in surgical cotton. Abdominal and skin incisions are sutured separately using a single horizontal mattress suture or several interrupted sutures. Neonatal splenectomy was described by Haller (1964). Genetic splenectomy was reported as a result of actions of the gene, dominant hemimelia (gene symbol *Dh*) (Searle, 1959). However, this pleiotrophic gene also causes malformations of the skeletal and digestive systems. Chemical splenectomy has also been reported (Fiala and Cinátl, 1978).

U. Thymectomy and Thoractomy

The thymus consists of two separate asymmetric glands located within the mediastinum (Siegler and Rich, 1963a). The mediastinal fascia and associated pleura usually completely separate the lungs and isolate the heart, thymus, and associated mediastinal lymph nodes. Therefore, it is possible to thymectomize a mouse without inducing pneumothorax as long as the mediastinal fascia remains intact.

Two surgical techniques have been developed for thymectomy of postweanling mice. One approach utilizes a longitudinal midline incision extending from the angle of the mandible to the level of the second or fourth rib (Gross, 1959; Miller, 1960; Sjödin *et al.*, 1963; Weksler *et al.*, 1974). Descriptions of the surgical procedures are especially complete in articles by Gross (1959) and Sjödin *et al.* (1963). The submaxillary salivary glands are retracted anteriorly, and the sternothyroid muscles are separated to expose the trachea and manubrium. The manubrium and first two or three sternabrae are incised longi-

tudinally using microdissecting scissors. The points of the scissors must be directed toward the sternum in order to avoid accidental puncture of the heart and great vessels. The thymus glands are removed one lobe at a time by suction through a 2.2-mm glass cannula. Injury to the adjacent vagus and recurrent laryngeal nerves should be avoided. Wound closure is accomplished by securing the edges of the skin with sutures or wound clips. This technique permits direct observation of the thymus.

An alternative technique (Lurie *et al.*, 1977) uses a similar midline longitudinal skin incision and blunt dissection of the fascia and muscles over the trachea. At this point, the sternothyroid muscle is incised on the midline and retracted laterally to expose the trachea. Elevating the operating table facilitates observation of the mediastinum and manubrium. The manubrium is elevated using curved microdissecting forceps until the thymus glands are visible. The thymus glands are aspirated, and the skin incision is sutured with 5-0 suture.

Newborn mice can be thymectomized through a transverse incision made through the sternum between the second and third ribs (East and Parrott, 1962), or through a midline longitudinal incision extending from the angle of the mandible to the fourth rib including incision of the manubrium (Sjödin *et al.*, 1963). The thymus is exposed by careful blunt dissection and aspirated through a 1.0-mm diameter glass cannula. Skin incisions are closed with a spray on plastic wound dressing or a single suture.

Thoracotomy to expose lungs or other structures within the pleural cavities requires artificial respiration. A simple positive pressure artificial respiration device for mice and an approach to thoracotomy are described by Siegler and Rich (1963b).

V. Thyroidectomy

The thyroid gland of the mouse consists of two lateral lobes that are usually located under the cervical muscles, alongside the trachea, between the cricoid cartilage and the first four tracheal rings. However, the exact location of the thyroid is subject to individual variation (Hummel *et al.*, 1975). Thyroidectomy of the mouse is accomplished by surgical excision or administration of radioactive iodine (Gorbman, 1950). To excise the thyroid gland, the anesthetized mouse is placed in a dorsal recumbant position with head extended. The head is extended by looping a rubber band around the upper incisors and securing the rubber band to a cork board. The ventral surface of the neck is prepared for surgery, and a ventral midline skin incision is made over the trachea, extending from the level of the salivary glands caudally toward the manubrium. The fascia of the longitudinal cervical muscles overlying the trachea is bluntly dissected on the midline and retracted laterally in order to visualize the lateral lobes of the thyroid. Thyroid vessels are crushed and torn with fine-pointed forceps as

the gland is gently dissected free of its attachments. The recurrent laryngeal nerves must be identified and kept intact during dissection. After excision of the gland, the edges of the cervical muscle are opposed, but not sutured. The skin incision is closed with a wound clip or one or two sutures. This technique is similar to that described for the rat (Ingle and Griffith, 1949). Thyroidectomy in the mouse usually results in partial parathyroidectomy because of the intimate relationship between these two endocrine glands (Hummel *et al.*, 1975). However, parathyroid tetany subsequent to thyroidectomy has not been a problem because the residual parathyroid tissue not associated with the thyroid remains intact.

W. Vasectomy

The vas deferens are paired tubules that transport sperm between the epididymus and urethra. The vas deferens pass through the inguinal canal and traverse the pelvic inlet to enter the dorsal wall of the urethra near the neck of the bladder. Vasectomy is performed through midline longitudinal ventral skin and abdominal incisions extending from the pubic symphysis toward the umbilicus. Each vas deferens is exteriorized by grasping it with a pair of fine forceps. Distal and proximal ligatures are placed 5 mm apart and that portion of the vas deferens between the ligatures is excised (Aitken and Carter, 1977). Accidental ligation or damage to the spermatic vessels or nerves results in atrophy of the testicle.

VIII. POSTANESTHETIC AND POSTOPERATIVE CARE

Strain or genotype of the mouse, the type of anesthetic, the duration of the procedure, and the amount of tissue trauma associated with the procedure must be considered when planning postoperative regimens for mice. Very short periods of anesthesia and quick procedures require no special postanesthetic care except returning the mouse to a clean, dry, warm cage and trimming long claws that might catch in sutures when the mouse grooms itself. Long procedures mandate more elaborate postoperative regimens. In general, very young mice, old endocrine mutant mice, and metabolic mutant mice require more "tender, loving" postoperative care than random-bred or hybrid young mice subjected to the same procedures. Major surgical procedures (thymectomy, ovarian transplant) should be scheduled during the early part of the work day, allowing observation of the mice until they have recovered from anesthesia. Minimum postoperative care includes placing the mice in a clean cage and warming the cage with a 50- to 75-W light bulb placed about 4–6 inches above the top of one end of the

cage. Mice should be placed in lateral or ventral recumbancy with the head slightly extended and level. This position maintains a patent airway and minimizes aspiration of salivary secretions. Reduction in cardiac output may be caused by increased intrathoracic pressure that results from the head being below the hindquarters. Subcutaneous or intraperitoneal administration of sterile physiological saline or balanced salt solutions should be considered if prolonged surgical or recovery periods are anticipated. Dextrose solution (5%) or corticosteroids should be administered subcutaneously immediately following hypophysectomy or adrenalectomy of normal inbred mice or surgical manipulation of homozygous endocrine mutant mice. Fluids are administered at the rate of 0.5–1 ml per 15–25 g body weight. In addition, supplemental oxygen may be advised for very old mice or mice subjected to extensive procedures (e.g., kidney transplant).

IX. EUTHANASIA

Mice can be humanely killed using several methods: carbon dioxide, cervical dislocation, anesthetic overdose, decapitation, or exsanguination. Advantages and disadvantages of each method were discussed in detail by the AVMA Panel on Euthanasia (McDonald, 1978).

Carbon dioxide is a safe humane way to kill large numbers of mice provided the chamber is filled with CO₂ before the mice are placed in it, mice are not crowded into the chamber, and CO₂ is replenished frequently. Adult mice are unconscious within 10–20 sec and dead within 2–4 min. Newborn mice are resistant to CO₂ and at least 10–15 min exposure to CO₂ should be allowed to assure death. Nitrogen (N₂) may be substituted for CO₂ provided the concentration is adequate (McDonald, 1978).

Cervical dislocation should be practiced on anesthetized mice until the technique is perfected. The mouse is placed on a flat surface and restrained by placing the thumb and forefinger of one hand at the base of the skull and grasping the tail with the other. The spinal cord is served by quickly moving the hand restraining the head forward and the hand holding the tail backward. After cervical dislocation, a 2–4 mm space can be palpated between the occipital condyles and the atlas. The most common errors made with cervical dislocation are: (1) placing the thumb and forefinger on the top of the skull over the parietal bone (2) exerting downward, rather than forward pressure, on the head, and (3) moving hands too slowly.

Overdoses of a variety of anesthetic agents have been used to euthanize animals (McDonald, 1978). The most common anesthetics used to kill mice are barbiturates and ether. Barbiturates are administered intraperitoneally or intravenously at least twice the anesthetic dose. Ether is administered by plac-

ing the mice in a covered jar (Fig. 9) containing cotton balls that have been moistened with ether. The mice are left in the jar until respiration has ceased for several minutes. The bodies of the mice killed by ether require special storage and disposal because of residual ether fumes in the bodies and the possibility of explosion (Moreland, 1978). Methoxyflurane and halothane can be used to euthanize mice, but the length of time required to kill mice and the expense of these anesthetics make them impractical for routine use. Ether and other inhalant anesthetics should not be used unless a fume hood is available. Chloroform should not be used because very low concentrations can be lethal to mice in adjacent cages (Vesell *et al.*, 1976), and it poses hazards to personnel using it (Moreland, 1978).

Decapitation by a guillotine or postmortem shears can be used to euthanize mice (Yngner, 1975). Although this procedure could be esthetically offensive, it is rapid, produces instant death when properly done (Mikeska and Klemm, 1975), and provides an excellent alternative to CO₂ for euthanasia of newborn. Blood collected following decapitation may be contaminated by salivary or respiratory secretions. Exsanguination by severing the brachial artery or abdominal aorta of anesthetized mice has been described by Young and Chambers (1973) and Lushbough and Moline (1961). Exsanguination without prior administration of anesthetics or sedatives is not recommended (McDonald, 1978), although exsanguination via orbital plexus or external jugular vein of unanesthetized mice has been described (Cate, 1969; Murine Virus Diagnostic Laboratory, 1978).

The method of euthanasia alters pathological and histopathological observations (Fawell *et al.*, 1972; Feldman and Gupta, 1976; Port *et al.*, 1978). Congestion of the lungs may be expected following carbon dioxide, ether, barbiturate overdose, and T-61. Ether may inactivate ether-sensitive viruses and should not be used to euthanize mice if viral isolation procedures are planned. Splenic congestion can be expected with barbiturate overdose. Rupture of cervical or thoracic blood vessels during cervical dislocation results in nasal or oral hemorrhages and/or hemothorax. Blood may be aspirated into the trachea and bronchi following decapitation or exsanguination via cervical vessels. In addition, visceral organs, e.g., liver, kidney, and spleen, are paler than normal due to blood loss if the mouse is exsanguinated.

X. DIAGNOSTIC PROCEDURES AND NECROPSY

A. Diagnostic Procedures

Postmortem decomposition of the mouse begins at the cellular level almost immediately after death. Autolysis of the small intestine is noticeable by the unaided eye within 1–2 hr after

death. Refrigeration of the dead mice retards autolysis to some extent. Necropsy of mice that have been dead for several hours is frustrating, since postmortem degeneration obscures subtle pathologic lesions. Sick mice are preferable to moribund or dead mice for complete diagnostic workup because evaluation of bacteriological cultures from moribund or dead mice is difficult due to the rapidity with which normal intestinal flora transverse the damaged intestinal wall. In order to maximize chances of isolating the virus, virus isolation procedures should be limited to fresh tissues from mice that are in the acute phases of the disease or from chronically infected immune deficient mice (nude, thymectomized, or irradiated mice).

Serological screening for viruses should be limited to mice that were clinically ill and have been recovered for 3–4 weeks or that have been in a facility for at least 5–6 weeks. Serological testing of weanling mice may be misleading because these mice may show low levels of passive maternal antibody or have not yet contracted the virus in question. Serological testing of immunologically deficient mice, e.g., nude (*nu/nu*) mice, is futile because they do not make enough antibody to be detected by routine serological techniques. Serological evaluation of mice with large amounts of anti-nuclear antibodies can be frustrating because they often give false positive or inconclusive results. Sera (blood) for serological testing can be collected from tail veins, jugular veins, brachial vessels, orbital sinus, or cardiac puncture (refer to Section IV). Contamination of blood with respiratory secretions or saliva should be avoided. Blood is allowed to clot at room temperature for several hours and then centrifuged or refrigerated overnight in order to maximize the yield of sera. Individual sera are collected, diluted 1:5 with sterile physiological buffered saline, heat inactivated at 56°C for at least 30 min, and stored in a refrigerator or frozen prior to testing.

Mice may be examined for ectoparasites by several methods. Dead mice are placed on a piece of black paper and surrounded with a circle of petroleum jelly or cellophane tape. After 12–20 hr, the carcass is discarded and the paper is examined for mites using a dissecting microscope ($\times 10$ – 20 magnification) (Flynn, 1963). Alternatively, anesthetized, restrained, or dead mice can be examined for mites by separating the pelage with a dissecting microscope ($\times 10$ – 20 magnification). Mites and lice, if present, are usually found on the muzzle, around the eyelids, at the base of the ears and occipital region, tail-head, and ventral abdomen (Baker *et al.*, 1967; Flynn, 1973) (see Weisbroth, Vol. 11, Chapter 21).

B. Necropsy

Before beginning the necropsy, the dead mouse is often dipped in a disinfectant solution, placed in dorsal recumbancy,

and secured to a corkboard. A midline ventral abdominal skin incision is made from the pubic symphysis to the body of the mandible, and the skin is reflected laterally. Subcutaneous tissues, superficial lymph nodes, mammary glands or preputial glands, and salivary glands are examined. Next the abdominal wall is incised through the linea alba from the pubic symphysis to the xyphoid cartilage, and bilateral incisions are directed laterally through xyphoid cartilage and the ribs toward the shoulder joint; the abdominal and the thoracic viscera are thus exposed. If bacteriological cultures or virus isolation procedures are planned, the abdominal and thoracic walls should be incised with sterile scissors, and a second set of sterile forceps and scissors is used to examine organs. Verstraete (1973) compared several techniques for obtaining lung or liver cultures from mice and found that insertion of a 2-mm bore sterile Pasteur pipette was best. Complete examination of the viscera should include examination of wet mounts of scrapings of small and large intestine for protozoa and incision of intestine and cecum in order to examine the contents for helminths.

After examination of the abdominal and thoracic viscera is completed, the osseous bulla is examined for evidence of inflammation; the bullae are exposed by disarticulating the lower jaw and scraping away the muscles attached cranially to the ventral surface of the occipital condyles. Middle ear cultures are obtained by aseptically excising a portion of the osseous bulla or by penetrating the osseous bulla with a 20- to 22-gauge hypodermic needle and flushing the tympanic cavity with appropriate culture media.

C. Histopathological Examination

Specimens for histopathological examination must be promptly placed in fixative. Fekete's modification of Tellyesniczky's fixative was developed specifically for mouse tissues and paraffin embedding because mouse tissues tend to become brittle if fixed in 10% unbuffered formalin (Fekete, 1953). A 2% formaldehyde, 3% glutaraldehyde fixative in cocodylate buffer has been developed for fetal mouse tissues, plastic embedding, and ultra thin sections (Eicher *et al.*, 1980). Rodent lung should be inflated prior to fixation (Egberts, 1972). Otherwise interpretation of lung lesions is complicated by atelectasis and other artifacts. For critical histological evaluations, perfusion of the organ may be desired; perfusion of the kidney (Haydon *et al.*, 1976; Neudeck and Fournier, 1980) and liver (Lee *et al.*, 1960) have been described. Prior to histopathologic examination of mouse specimens, one should be aware of idiosyncrasies of the mouse and sex or strain differences, such as extramedullary hematopoiesis, irregular focal peribronchial lymphoid accumulations, minute focal macrophage infiltrates in the interstitium of the kidney, X zone in adrenals of immature female mice, and

tall columnar cells lining salivary gland tubules and Bowman's capsule of adult male mice (E. L. Green, 1975; Cotchin and Roe, 1967). Strain predispositions for tumors and other constitutional diseases have been described in the "Biology of the Laboratory Mouse" (E. L. Green, 1975) and more recently in Volume IV of this treatise. In addition, bacteriological or reproductive status influence histopathologic observations. Cecal hypertrophy and lymphoid hypoplasia are expected in germfree mice. Also, splenic hyperplasia of intestinal mucosa are expected in term pregnant or lactating female mice.

ACKNOWLEDGMENTS

I would like to thank the many members of The Jackson Laboratory research staff and their assistants who generously made available procedures that have been passed by word-of-mouth and helped locate original references that were almost lost in antiquity. This project supported by institutional funds of The Jackson Laboratory.

REFERENCES

- Abel, H. H., and Bartling, H. (1978). Narcosis with carbon dioxide for short lasting treatment of small research animals. *Z. Versuchstierkd.* **20**, 132-136 (in German).
- Aitken, R. J., and Carter, J. (1977). Behavioural consequences of vasectomy in the mouse. *Experientia* **33**, 1396-1397.
- Ambrus, J. L., Ambrus, C. M., Harrison, J. W. E., Leonard, C. A., Moser, C. E., and Cravitz, H. (1951). Comparison of methods for obtaining blood from mice. *Am. J. Pharm.* **123**, 100-104.
- Andersen, D. H., and Wolf, A. (1934). Pinealectomy in rats. *J. Physiol. (London)* **81**, 49-62.
- Anderson, N. F., Delorme, E. J., Woodruff, M. F. A., and Simpson, D. C. (1959). An improved technique for intravenous injection of newborn rats and mice. *Nature (London)* **184**, 1952-1953.
- Anonymous (1962). Method of B.S.P. test for an assessment of liver function in mice. *Exp. Anim.* **11**, 31-32. (in Japanese Engl. abstr.).
- Archuleta, R. F. (1977). An improved device for animal immobilization during tumor irradiation. *Lab. Anim. Sci.* **27**, 703-704.
- Arko, R. J. (1973). Implantation and use of subcutaneous culture chamber in laboratory animals. *Lab. Anim. Sci.* **23**, 105-106.
- Avery, D. L., and Spyker, J. M. (1977). Foot tattoo of neonatal mice. *Lab. Anim. Sci.* **27**, 110-111.
- Baden, J. M., Egbert, B., and Rice, S. A. (1980). Enflurane has no effect on haemopoiesis in mice. *Br. J. Anaesth.* **52**, 471-474.
- Baggot, J. D. (1977). Disposition and fate of drugs in the body. In "Veterinary Pharmacology and Therapeutics" (L. M. Jones, N. H. Booth, and L. E. McDonald, eds.), 4th ed., pp. 43-78. Iowa State Univ. Press, Ames.
- Bailey, D. W., and Usama, B. (1960). A rapid method of grafting skin on tails of mice. *Transplant. Bull.* **7**, 424-425.
- Baker, E. W., Evans, T. M., Gould, D. J., Hull, W. B., and Keegan, H. L. (1967). "A Manual of Parasitic Mites of Medical or Economic Importance." Henry Tripp, Woodhaven, New York.

- Barnes, C. D., and Eltherington, L. G. (1964). "Drug Dosage in Laboratory Animals: A Handbook." Univ. of California Press, Berkeley and Los Angeles.
- Barnes, D. W. H., Ford, C. E., and Harris, J. E. (1963). Intravenous injection of young mice. *Transplantation* **1**, 574.
- Barnett, S. A. (1956). Endothermy and ectothermy in mice at -3°C . *J. Exp. Biol.* **33**, 124-133.
- Barrow, M. V. (1968). Modified intravenous injection technique in rats. *Lab. Anim. Care* **18**, 570-571.
- Beamer, W. G. (1981). The Jackson Laboratory, Bar Harbor, Maine (personal communication).
- Beatty, R. A. (1951). Transplantation of mouse eggs. *Nature (London)* **168**, 995.
- Becker, B. A., and Plaa, G. L. (1967). Assessment of liver function in mice. *Lab. Anim. Care* **17**, 267-272.
- Bell, E. T., Christie, D. W., and Parkes, M. F. (1971). Timing of gonadotrophin induced ovulation and its inhibition in immature mice. *Lab. Anim.* **5**, 67-71.
- Benson, L. M., and Abelseh, M. K. (1975). Parabiosis in Nya: NYLAR mice. *Lab. Anim. Sci.* **25**, 157-161.
- Bergström, S. (1971). A simple device for intravenous injection in the mouse. *Lab. Anim. Sci.* **21**, 600-601.
- Beven, J. L. (1980). A new system for monitoring respiratory patterns of small laboratory animals. *Lab. Anim.* **14**, 133-135.
- Billingham, R. E. (1954). The technique of mouse skin grafting. *Transplant. Bull.* **1**, 184-186.
- Billingham, R. E., and Brent, L. (1956). Acquired tolerance of foreign cells in newborn animals. *Proc. R. Soc. London, Ser. B.* **146**, 78-90.
- Billingham, R. E., and Medawar, P. B. (1951). The technique of free skin grafting in mammals. *J. Exp. Biol.* **28**, 385-402.
- Billings, T. A. (1967). A holder to facilitate the intravenous injection of mice. *Lab. Anim. Care* **17**, 521-523.
- Boak, J. L., and Woodruff, M. F. A. (1965). A modified technique for collecting mouse thoracic duct lymph. *Nature (London)* **205**, 396-397.
- Boggs, S. S. (1978). Stand for mouse holder. *Lab. Anim. Sci.* **28**, 98.
- Boutelle, J. L., and Oper, D. (1967). Mouse immobilizer and radiation shield. *Lab. Anim. Care* **17**, 253-254.
- Boutelle, J. L., and Rich, S. T. (1969). An anesthetic chamber for prolonged immobilization of mice during tumor transplantation and radiation procedures. *Lab. Anim. Care* **19**, 666-667.
- Bronson, F. H., Dagg, C. P., and Snell, G. D. (1975). Reproduction. In "Biology of the Laboratory Mouse" (E. L. Green, ed.), 2nd ed., pp. 187-204. Dover, New York.
- Bryant, B. F., and Bernard, V. M. (1955). A new method for bandaging mice receiving free skin grafts. *Transplant. Bull.* **2**, 133-134.
- Buchsbaum, M., and Buchsbaum, R. (1962). Age and ether anesthesia in mice. *Proc. Soc. Exp. Biol. Med.* **109**, 68-70.
- Bunster, E., and Meyer, R. K. (1933). An improved method of parabiosis. *Anat. Rec.* **57**, 339-343.
- Cabe, P. A., and Tilson, H. A. (1978). Hind limb extensor response: A method for assessing motor dysfunction in rats. *Pharmacol., Biochem. Behav.* **9**, 133-136.
- Cabe, P. A., Tilson, H. A., Mitchell, C. L., and Dennis, R. (1978). A simple recording grip strength device. *Pharmacol., Biochem. Behav.* **8**, 101-102.
- Cancer Research Genetics Laboratory, University of California (1963). Current applications of a method of transplantation of tissues into glandfree mammary fat pads of mice. In "Methodology in Mammalian Genetics" (W. J. Burdette, ed.), pp. 565-569. Holden-Day, San Francisco, California.
- Casals, J., and Olitsky, P. K. (1946). Tests for hepatic dysfunction of mice. *Proc. Soc. Exp. Biol. Med.* **63**, 383-390.
- Cass, J. S., Campbell, I. R., and Lange, L. (1960). A guide to production, care and use of laboratory animals. An annotated bibliography. *Fed. Proc., Fed. Am. Soc. Exp. Biol.* **19**, No. 4, Part III, 116-132.
- Cate, C. C. (1969). A successful method for exsanguinating unanesthetized mice. *Lab. Anim. Care* **19**, 256-258.
- Catz, C., and Yaffe, S. J. (1967). Strain and age variation in hexobarbital response. *J. Pharmacol. Exp. Ther.* **155**, 152-156.
- Chambers, T. R. (1975). An aseptic peritoneal cell collection technique for small laboratory animals. *Lab. Anim. Sci.* **25**, 619-620.
- Champlin, A. K., and McGill, T. E. (1967). A simple restraining device for injecting mice. *Lab. Anim. Care* **17**, 600-601.
- Champlin, A. K., Dorr, D. L., and Gates, A. H. (1973). Determining the stage of the estrous cycle in the mouse by the appearance of the vagina. *Biol. Reprod.* **8**, 491-494.
- Chapman, A. L. (1968). Leucocyte values of normal and adrenalectomized male and female C57BL/Cn mice. *Lab. Anim. Care* **18**, 616-622.
- Checiu, M., Amels, D., Sandor, S., and Sugiu, A. (1977). Contributions to the transfer of preimplantation mouse embryos into "foster-mothers." *Rev. Roum. Morphol., Embryol. Physiol., Morphol. Embryol.* **23**, 175-180.
- Chen, G., Ensor, C. R., and Bohner, B. (1966). The neuropharmacology of 2-(*o*-chloro-phenyl)-2-methylaminocyclohexanone hydrochloride. *J. Pharmacol. Exp. Ther.* **152**, 332-339.
- Cicciarelli, J. C., Cooper, M. D., and Myers, W. L. (1979). Prolongation of mouse skin allograft by splenectomy and lymphnodectomy following transplantation. *Immunol. Commun.* **8**, 249-262.
- Clark, P. A., and Harland, W. A. (1969). Device for intragastric fluid administration to the rat. *Lab. Anim.* **3**, 61-63.
- Coles, E. H. (1974). "Veterinary Clinical Pathology," 2nd ed. Saunders, Philadelphia, Pennsylvania.
- Conner, M. K., Dombroske, R., and Cheng, M. (1980). A simple device for continuous intravenous infusion of mice. *Lab. Anim. Sci.* **30**, 212-214.
- Conway, H., and Stark, R. B. (1954). The technique of mouse skin grafting. *Transplant. Bull.* **1**, 186-187.
- Cook, M. J. (1965). "The Anatomy of the Laboratory Mouse." Academic Press, New York.
- Corbeil, L. B., Wunderlich, A. C., and Braude, A. I. (1978). Technique for transcervical intrauterine inoculations of the mouse. *Lab. Anim. Sci.* **28**, 314-316.
- Corry, R. J., Winn, H. J., and Russell, P. S. (1973). Heart transplantation in congenic strains of mice. *Transplant. Proc.* **5**, 733-735.
- Cotchin, E., and Roe, F. J. C., eds. (1967). "Pathology of Laboratory Rats and Mice." Davis, Philadelphia, Pennsylvania.
- Coupland, R. E. (1960). The postnatal distribution of the abdominal chromaffin tissue in the guinea pig, mouse and white rat. *J. Anat.* **94**, 244-256.
- Crispens, C. G., and Kaliss, N. (1961). A simple device for facilitating injections in the tail veins of mice. *Am. J. Clin. Pathol.* **35**, 387-388.
- Cubitt, J. G. K., and Barrett, C. P. (1978). A comparison of serum calcium levels obtained by two methods of cardiac puncture in mice. *Lab. Anim. Sci.* **28**, 347.
- Cunliffe-Beamer, T. L., Freeman, L. C., and Myers, D. D. (1981). Barbiturate sleeptime in two strains of mice exposed to four different autoclaved or unautoclaved wood beddings. *Lab. Anim. Sci.* **31**, 672-675.
- Davis, W. M. (1962). Day-night periodicity in penobarbital response of mice and influence of socio-psychological conditions. *Experientia* **18**, 235-237.
- DeJong, R. H., and Bonin, J. D. (1980). Deaths from local anesthetic induced convulsions in mice. *Anesth. Analg. (Cleveland)* **59**, 401-405.
- Delanoy, R. L., Dunn, A. J., and Tintner, R. (1978). Behavioral responses to intracerebroventricularly administered neurohypophyseal peptides in mice. *Horm. Behav.* **11**, 348-362.

- DeOme, K. B., Faulkin, L. J., Jr., Bern, H. A., and Blair, P. B. (1959). Development of mammary tumors from hyperplastic alveolar nodules transplanted into gland-free mammary fat pads of C3H mice. *Cancer Res.* **19**, 515-520.
- Deringer, M. K., Dunn, T. B., and Heston, W. E. (1953). Results of exposure of strain C3H mice to chloroform. *Proc. Soc. Exp. Biol. Med.* **83**, 474-479.
- Dickerman, J. D., Bolton, E., Coil, J. A., Chalmer, B. J., and Jakab, G. J. (1979a). Protective effect of prophylactic penicillin on splenectomized mice exposed to an aerosolized suspension of type III *Streptococcus pneumoniae*. *Blood* **53**, 498-503.
- Dickerman, J. D., Horner, S. R., Coil, J. A., and Gump, D. W. (1979b). The protective effect of intraperitoneal splenic autotransplants in mice exposed to an aerosolized suspension of type III *Streptococcus pneumoniae*. *Blood* **54**, 354-358.
- Dickie, M. M. (1975). Keeping records. In "Biology of the Laboratory Mouse" (E. L. Green, ed.), 2nd ed., pp. 23-27. Dover, New York.
- Dolowy, W. C., Mombelloni, P., and Hesse, A. L. (1960). Chlorpromazine premedication with pentobarbital anesthesia in a mouse. *Am J. Vet. Res.* **21**, 156-157.
- Douglas, W. B., Jr. (1972). Sciatic cross-innervation of parabiotic mice. I. Surgical method and comments on animal care. *Lab. Anim. Sci.* **22**, 559-564.
- Duben, S. (1968). A method for numbering laboratory animals using the binary number system. *Lab. Anim. Care* **18**, 574-576.
- Dudley, W. R., Soma, L. R., Barnes, C., Smith, T. C., and Marshall, B. E. (1975). An apparatus for anesthetizing small laboratory animals. *Lab. Anim. Sci.* **25**, 481-482.
- Dunn, J. R., and Stern, J. S. (1978). Feeder for measuring food intake in the mouse. *Lab. Anim. Sci.* **28**, 97.
- Dunn, T. B. (1949a). Some observations of the normal and pathologic anatomy of the kidney of the mouse. *JNCI, J. Natl. Cancer Inst.* **9**, 285-301.
- Dunn, T. B. (1949b). Melanoblasts in the stroma of the parathyroid glands of strain C58 mice. *JNCI, J. Natl. Cancer Inst.* **10**, 725-733.
- Dux, A. (1962). Total mastectomy in female mice and rats. *Nature (London)* **196**, 287-288.
- East, J., and Parrott, D. M. V. (1962). Operative techniques for newborn mice using anaesthesia by cooling. *J. Endocrinol.* **24**, 249-250.
- Ebbe, S., Phalen, E., and Howard, D. (1978). Parabiotic demonstration of a humoral factor affecting megakaryocyte size in *Sl/Sl^d* mice. *Proc. Soc. Exp. Biol. Med.* **158**, 637-642.
- Edwards, J. W., Sloan, R. F., Bleicher, N., and Ashley, F. L. (1959). An ether chamber for small laboratory animals. *Proc. Anim. Care Panel* **9**, 71-73.
- Egberts, J. (1972). Fixation of rat lungs under physiologically defined conditions. *Lab. Anim.* **6**, 351-356.
- Eicher, E. M., Beamer, W. G., Washburn, L. L., and Whitten, W. K. (1980). A cytogenetic investigation of inherited true hermaphroditism in BALB/c Wt mice. *Cytogenet. Cell Genet.* **28**, 104-115.
- Einheber, A., Wren, R. E., Carter, D., and Rose, L. R. (1967). A simple collar device for the protection of skin grafts in mice. *Lab. Anim. Care* **17**, 345-348.
- Erway, L., Hurley, L. S., and Fraser, A. S. (1969). Congenital ataxia and otolith defects due to manganese deficiency in mice. *Nutrition* **100**, 643-654.
- Falabella, F. (1967). Bleeding mice: A successful technique of cardiac puncture. *J. Lab. Clin. Med.* **70**, 981-982.
- Falconi, G., and Rossi, G. L. (1964). Transauricular hypophysectomy in rats and mice. *Endocrinology* **74**, 301-303.
- Fall, M. W. (1974). The use of red light for handling wild rats. *Lab. Anim. Sci.* **24**, 686-687.
- Farrell, R. K., and Johnston, S. D. (1973). Identification of laboratory animals: Freeze marking. *Lab. Anim. Sci.* **23**, 107-110.
- Faulkin, L. J., Jr., and DeOme, K. B. (1958). The effect of estradiol and cortisol on the transplantability and subsequent fate of normal, hyperplastic and tumorous mammary tissue of C3H mice. *Cancer Res.* **18**, 51-56.
- Fawell, J. K., Thomson, C., and Cooke, L. (1972). Respiratory artefact produced by carbon dioxide and pentobarbital sodium euthanasia in rats. *Lab. Anim.* **6**, 321-326.
- Feigelson, M., Feigelson, P., and Gross, P. R. (1958). Xanthine oxidase activity in regenerating liver. *J. Gen. Physiol.* **41**, 233-242.
- Fekete, E. (1939). Results of attempted total mastectomy in mice of a high tumor strain. *Anat. Rec.* **73**, 319-325.
- Fekete, E. (1953). A morphological study of the ovaries of virgin inbred mice of eight inbred strains showing quantitative difference in their hormone producing components. *Anat. Rec.* **117**, 93-113.
- Fekete, E., and Little, C. C. (1942). Observations on the mammary tumor incidence in mice born from transferred ova. *Cancer Res.* **2**, 525-530.
- Feldman, D. B., and Gupta, B. N. (1976). Histopathologic changes in laboratory animals resulting from various methods of euthanasia. *Lab. Anim. Sci.* **26**, 218-221.
- Feller, W. F., and Boretos, J. (1967). Semi-automatic apparatus for milking mice. *JNCI, J. Natl. Cancer Inst.* **38**, 11-17.
- Ferguson, H. C. (1966). Effect of red cedar chip bedding on hexobarbital and pentobarbital sleeptime. *J. Pharm. Sci.* **55**, 1142-1148.
- Fiala, J., and Cinátl, J. (1978). Chemical splenectomy and the number of haematopoietic stem cells. *Czech. Med.* **1**, 122-127.
- Fields, B. T., Jr., and Cunningham, D. R. (1976). A tail artery technique for collecting one-half milliliter of blood from a mouse. *Lab. Anim. Sci.* **26**, 505-506.
- Finerty, J. C. (1952). Parabiosis in physiological studies. *Physiol. Rev.* **32**, 277-302.
- Fleischman, R. W., McCracken, D., and Forbes, W. (1977). Adynamic ileus in the rat induced by chloral hydrate. *Lab. Anim. Sci.* **27**, 238-243.
- Flynn, R. J. (1963). The diagnosis of some forms of ectoparasitism of mice. *Lab. Anim. Care* **13**, 111-125.
- Flynn, R. J. (1973). "Parasites of Laboratory Animals," p. 377. Iowa State Univ. Press, Ames.
- Fowler, J. S. L., Brown, J. S., and Flower, E. W. (1980). Comparison between ether and carbon dioxide anesthesia for removal of small blood samples from rats. *Lab. Anim.* **14**, 275-278.
- Fowler, R. E., and Edwards, R. G. (1957). Induction of superovulation and pregnancy in mature mice by gonadotrophins. *J. Endocrinol.* **15**, 374-384.
- Frankenberg, L. (1979). Cardiac puncture in the mouse through the anterior thoracic aperture. *Lab. Anim.* **13**, 311-312.
- Fuller, J. L., and Wimer, R. E. (1975). Neural, sensory, and motor functions. In "Biology of the Laboratory Mouse" (E. L. Green, ed.), 2nd ed., pp. 609-628. Dover, New York.
- Furner, R. L., and Mellett, L. B. (1975). Mouse restraining chamber for tail vein injection. *Lab. Anim. Sci.* **25**, 648-649.
- Furukawa, Y., Kashima, M., and Matsuoka, O. (1966). Fundamental studies on gaseous metabolism of mice. *Exp. Anim.* **15**, 1-5 (in Japanese Engl. abstr.).
- Galloway, J. H. (1968). Antibiotic toxicity in white mice. *Lab. Anim. Care* **18**, 421-425.
- Gates, A. H. (1971). Maximizing yield and developmental uniformity of eggs. In "Methods in mammalian Embryology" (J. C. Daniel, Jr., ed.), pp. 64-75. Freeman, San Francisco, California.
- Gesner, B. M., and Gowans, J. L. (1962). The output of lymphocytes from the thoracic duct of unanaesthetized mice. *Br. J. Exp. Pathol.* **43**, 424-430.

- Gibson, J. E., and Becker, B. A. (1967). The administration of drugs to one day old animals. *Lab. Anim. Care* **17**, 524-527.
- Gomwalk, N. E., and Healing, T. D. (1981). Etomidate: A valuable anaesthetic for mice. *Lab. Anim.* **15**, 151-152.
- Gorbman, A. (1950). Functional and structural changes consequent to high dosages of radioactive iodine. *J. Clin. Endocrinol.* **10**, 1177-1191.
- Gottfried, B., and Padnos, M. (1959). A simple rapid method for skin grafting in mice. *Transplant. Bull.* **6**, 427-429.
- Grazer, F. M. (1958). Technique for intravascular injection and bleeding of newborn rats and mice. *Proc. Soc. Exp. Biol. Med.* **99**, 407-409.
- Green, C. J. (1975). Neuroleptanalgesic drug combinations in the anaesthetic management of small laboratory animals. *Lab. Anim.* **9**, 161-178.
- Green, C. J. (1979). "Laboratory Animal Handbooks 8: Animal Anaesthesia," pp. 147-154. Laboratory Animals Ltd., London.
- Green, C. J., Halsey, M. J., Precious, S., and Wardley-Smith, B. (1978). Alphaxolone-alphadolone anaesthesia in laboratory animals. *Lab. Anim.* **12**, 85-89.
- Green, C. J., Knight, J., Precious, S., and Simpkin, S. (1981a). Ketamine alone and combined with diazepam or xylazine in laboratory animals: A 10 year experience. *Lab. Anim.* **15**, 163-170.
- Green, C. J., Knight, J., Precious, S., and Simpkin, S. (1981b). Metomidate, etomidate and fentanyl as injectable anaesthetic agents in mice. *Lab. Anim.* **15**, 171-175.
- Green, E. L., ed. (1975). "Biology of the Laboratory Mouse," 2nd ed. Dover, New York.
- Greene, R., and Feder, B. H. (1968). Use of methoxyflurane as a chemical immobilizer for nonsurgical procedures. *Lab. Anim. Care* **18**, 382-386.
- Greenham, L. W. (1978). Tattooing newborn albino mice in life-span experiments. *Lab. Anim. Sci.* **28**, 346.
- Grice, H. C. (1964). Methods for obtaining blood and for intravenous injections in laboratory animals. *Lab. Anim. Care* **14**, 483-493.
- Grollman, A. (1941). Biological assay of adrenal cortical activity. *Endocrinology* **29**, 855-861.
- Gross, L. (1959). Effect of thymectomy on development of leukemia in C3H mice inoculated with leukemic "passage" virus. *Proc. Soc. Exp. Biol. Med.* **100**, 325-328.
- Gross, L., Padnos, M., and Gottfried B. (1960). A rapid method of skin grafting—Improved technique. *Transplant. Bull.* **7**, 421-423.
- Haberman, B. H. (1974). Mechanical milk collection from mice for Bittner virus isolation. *Lab. Anim. Sci.* **24**, 935-937.
- Hagen, E. O., and Hagen, J. M. (1964). A method of inhalation anaesthesia for laboratory mice. *Lab. Anim. Care* **14**, 13-15.
- Haller, J. A., Jr. (1964). The effect of neonatal splenectomy on mortality from runt disease in mice. *Transplantation* **2**, 287-291.
- Halloran, P. F., Ziv, I., Lee, E. H., Langer, F., Pritzker, K. P. H., and Gross, A. E. (1979). Orthotopic bone transplantation in mice. I. Technique and assessment of healing. *Transplantation* **27**, 414-419.
- Hamilton, P. B., Rutledge, J. H., and Boegli, G. (1967). An artifact associated with intraperitoneal injections of a nonaqueous vehicle in mice. *Lab. Anim. Care* **17**, 362-364.
- Hanrahan, J. P., and Eisen, E. J. (1971). A lactation curve for mice. *Lab. Anim. Care* **20**, 101-104.
- Hardin, C. A. (1954). The technique of mouse skin grafting. *Transplant. Bull.* **1**, 186.
- Harding, J. W., and Wright, J. W. (1979). Reversible effects of olfactory nerve section on behavior and biochemistry in mice. *Brain Res. Bull.* **4**, 17-22.
- Harrison, D. E., and Archer, J. R. (1978). Measurement of changes in mouse tail collagen with age: Temperature dependence and procedural details. *Exp. Gerontol.* **13**, 75-82.
- Hata, T., and Kita, T. (1978). A newly designed method for removal of the pineal body, and depression of convulsions and enhancement of exploratory movements by pinealectomy in mice. *Endocrinol. Jpn.* **25**, 407-413.
- Haydon, A., Thomas, J. H., Nielsen, A. H., and Werder, A. A. (1976). A simple technique for kidney perfusion in the mouse. *Lab. Anim. Sci.* **26**, 958-959.
- Heidt, G. (1978). A portable anesthesia chamber for intractable small animals. *Lab. Anim. Sci.* **28**, 212-213.
- Higashi, A., Uchizono, K., Hoshino, N., Tani, Y., Yano, T., and Yazawa, K. (1979). New technique for E. E. G. recording and drug infusion in the free-moving mouse. *Med. Biol. Eng. Comput.* **17**, 131-132.
- Holman, S. D. (1980). A method for intracerebrally implanting crystalline hormones into neonatal rodents. *Lab. Anim.* **14**, 263-266.
- Hoppe, P. C. (1976). Glucose requirement for mouse sperm capacitation *in vitro*. *Biol. Reprod.* **15**, 39-45.
- Hoppe, P. C., and Pitts, S. (1973). Fertilization *in vitro* and development of mouse ova. *Biol. Reprod.* **8**, 420-426.
- Hummel, K. P. (1958). Accessory adrenal cortical nodules in the mouse. *Anat. Rec.* **132**, 281-295.
- Hummel, K. P., Richardson, F. L., and Fekete, E. (1975). Anatomy. In "Biology of the Laboratory Mouse" (E. L. Green, ed.), 2nd ed., pp. 247-307. Dover, New York.
- Hunziker, J. (1975). A new feeder system for quantitating actual toxicant consumption by mice during feeding studies. *Lab. Anim. Sci.* **25**, 85-87.
- Hurley, L. S. (1968). Approaches to the study of nutrition in mammalian development. *Fed. Proc., Fed. Am. Soc. Exp. Biol.* **27**, 193-198.
- Ingle, D. J., and Griffith, J. Q. (1949). Surgery of the rat. In "The Rat in Laboratory Investigation" (E. J. Farris and J. Q. Griffith, eds.), 2nd ed., pp. 434-451. Lippincott, Philadelphia, Pennsylvania.
- Ino, T. (1961). Studies on the techniques for the artificial insemination in mice and rats. *Exp. Anim.* **10**, 107-110 (in Japanese, Engl. abstr.).
- Jaffe, R. A., and Free, M. J. (1973). A simple endotracheal intubation technique for inhalation anaesthesia of the rat. *Lab. Anim. Sci.* **23**, 266-269.
- Jay, G. E., Jr. (1955). Variation in response of various mouse strains to hexobarbital (Evipal). *Proc. Soc. Exp. Biol. Med.* **90**, 378-380.
- Jennings, F. B., Lewis, G. E., Jr., and Crumrine, M. H. (1972). A protective device for mouse tail skin grafts. *Lab. Anim. Sci.* **22**, 428-429.
- Johnson, H. N. (1974). Rabiesvirus. In "Manual of clinical microbiology" (E. H. Lennette, E. H. Spaulding, and J. P. Traunt, eds.), 2nd ed., pp. 746-753. Am. Soc. Microbiol., Washington, D.C.
- Jones, E. C., and Krohn, P. L. (1960). Orthotopic ovarian transplantation in mice. *J. Endocrinol.* **20**, 135-146.
- Jones, L. D. (1965). The faultless mouse holder. *Lab. Anim. Care* **15**, 373-374.
- Kahler, H. (1942). Apparatus for milking mice. *JNCI, J. Natl. Cancer Inst.* **2**, 457-458.
- Kahn, S. G. (1966). Small laboratory animal feeding techniques. *Lab. Anim. Care* **16**, 80-81.
- Kaplun, A., and Barishak, R. Y. (1976). Appearance of keratitis in laboratory mice: Influence of azathioprine and meticorten. *Lab. Anim.* **10**, 105-109.
- Kaplun, A., and Wolf, I. (1972). A device for restraining and intravenous injection of mice. *Lab. Anim. Sci.* **22**, 223-224.
- Kassel, R., and Levitan, S. (1953). A jugular technique for repeated bleeding of small animals. *Science* **118**, 563-564.
- Kawashima, Y., Sugimura, M., Hwang, Y.-C., and Kudo, N. (1964). The lymph system in mice. *Jpn. J. Vet. Res.* **12**, 69-81.
- Keighley, G. (1966). A device for intravenous injection of mice and rats. *Lab. Anim. Care* **16**, 185-187.
- Koerker, R. M. (1974). A feeder for controlling food consumption in treatment—Control pairs of mice. *Lab. Anim. Sci.* **24**, 535-536.

- Krohn, P. L. (1963). Transplantation of endocrine organs. In "Techniques in Endocrine Research" (P. Eckstein and F. Knowles, eds.), pp. 195-200. Academic Press, New York.
- Krueger, G. (1971). Mapping of the mouse brain for screening procedures with the light microscope. *Lab. Anim. Sci.* **21**, 91-105.
- Kumar, R. K. (1979). Toe clipping procedure for individual identification of rodents. *Lab. Anim. Sci.* **29**, 679-680.
- Lane, G. A., Nahrwold, M. L., Tait, A. R., Taylor-Busch, M., and Cohen, P. J. (1980). Anesthetic as teratogens: Nitrous oxide is toxic, xenon is not. *Science* **210**, 899-901.
- Lawson, R. L., Barranco, S., and Sorenson, A. M., Jr. (1966). A device to restrain the mouse, rat, hamster and chinchilla to facilitate semen collection and other reproductive studies. *Lab. Anim. Care* **16**, 72-79.
- Leckie, P. A., Watson, J. G., and Chaykin, S. (1973). An improved method for the artificial insemination of the mouse (*Mus musculus*). *Biol. Reprod.* **9**, 420-425.
- Lee, Y. P., Elias, H., and Davidsohn, I. (1960). Vascular pattern in the liver of the mouse. *Proc. Anim. Care Panel* **10**, 25-32.
- Lehmann, A. (1974). "Atlas stéréotaxique du cerveau de la souris." CNRS, Paris.
- Lewis, G. E., Jr., and Jennings, P. B., Jr. (1972). Effective sedation of laboratory animals using Innovar-Vet. *Lab. Anim. Sci.* **22**, 430-432.
- Lewis, R. E., Kunz, A. L., and Bell, R. E. (1966). Error of intraperitoneal injections in rats. *Lab. Anim. Care* **16**, 505-509.
- Lewis, V. J., Thacker, W. L., Mitchell, S. H., and Baer, G. M. (1976). A new technique for obtaining blood from mice. *Lab. Anim. Sci.* **26**, 211-213.
- Libbin, R. M., and Person, P. (1979). Neonatal rat surgery: Avoiding maternal cannibalism. *Science* **206**, 66.
- Liebenberg, S. P., van Almen, R. L., Schaeffers, F. F., Adkins, G. C., and Ericson, D. (1980). A new technique for restraint of mice. *Lab. Anim. Sci.* **30**, 905-906.
- Llaurado, J. G. (1958). A method for rapid adrenalectomy in the rat. *J. Anim. Tech. Assoc.* **8**, 75-78.
- Lothrop, A. J., and Jordan, C. W., Jr. (1955). Improved procedure for hypohysectomy of the mouse. *Proc. Soc. Exp. Biol. Med.* **90**, 267-269.
- Lukasewycz, O. A. (1976). A mouse restrainer for intravenous injection. *Lab. Anim. Sci.* **26**, 825.
- Lumb, W. V. (1963). "Small Animal Anesthesia." Lea & Febiger, Philadelphia, Pennsylvania.
- Lurie, D., Cicciarelli, J. C., and Myers, W. L. (1977). Thymectomy in the adult mouse: A new approach. *Lab. Anim. Sci.* **27**, 235-237.
- Lushbough, C. H., and Moline, S. W. (1961). Improved terminal bleeding method. *Proc. Anim. Care Panel* **11**, 305-308.
- McBurney, J. J., Meier, H., and Hoag, W. G. (1964). Device for milking mice. *J. Lab. Clin. Med.* **64**, 485-487.
- McCarthy, D. A., Chen, G., Kaump, D. H., and Ensor, C. (1965). General anesthetic and other pharmacological properties of 2-(O-chlorophenyl)-2-methylaminocyclohexanone-HCl (C1-581). *J. New Drugs* **5**, 21-33.
- McDonald, L. E. (Chr.) (1978). Report of the AVMA Panel on Euthanasia. *J. Am. Vet. Med. Assoc.* **173**, 59-72.
- Macedo-Sobrinho, B., Roth, G., and Grellner, T. (1978). Tubular device for intraoral examination of rodents. *Lab. Anim.* **12**, 137-139.
- McIntyre, J. W. R. (1971). An introduction of general anaesthesia of experimental animals. *Lab. Anim.* **5**, 99-114.
- McLaren, A. (1961). Some causes of variation of body temperature in mice. *Q. J. Exp. Physiol. Cogn. Med. Sci.* **46**, 38-45.
- McMaster, P. D. (1941). A method to determine the peripheral blood pressure in the mouse. *J. Exp. Med.* **74**, 29-40.
- Markowitz, J., Archibald, J., and Downie, H. G. (1964). "Experimental Surgery," 5th ed. Williams & Wilkins, Baltimore, Maryland.
- Marsk, L., and Larsson, K. S. (1974). A simple method for nonsurgical blastocyst transfer in mice. *J. Reprod. Fertil.* **37**, 393-398.
- Martin, K. H., and Richmond, M. E. (1972). A method for repeated sampling of testis tissue from small mammals. *Lab. Anim. Sci.* **22**, 541-545.
- Mauderly, J. L. (1975). An anesthetic system for small laboratory animals. *Lab. Anim. Sci.* **25**, 331-333.
- Mauderly, J. L. (1977). Bronchopulmonary lavage in small laboratory animals. *Lab. Anim. Sci.* **27**, 255-261.
- Mayer, J., Russell, R. E., Bates, M. W., and Dickie, M. M. (1950). Basal oxygen consumption of hereditarily obese and diabetic mice. *Endocrinology* **50**, 318-323.
- Medin, N. I., Osebold, J. W., and Zee, Y. C. (1976). A procedure for pulmonary lavage in mice. *Am. J. Vet. Res.* **37**, 237-238.
- Mikeska, J. A., and Klemm, W. R. (1975). EEG evaluation of humaneness of asphyxia and decapitation euthanasia of the laboratory rat. *Lab. Anim. Sci.* **25**, 175-179.
- Miller, J. F. A. P. (1960). Studies on mouse leukaemia. The role of the thymus in leukaemogenesis by cell-free leukaemic filtrates. *Br. J. Cancer* **14**, 93-98.
- Minasian, H. (1980). A simple tourniquet to aid mouse tail venipuncture. *Lab. Anim.* **14**, 205.
- Moler, T. L., Donahue, S. E., and Anderson, G. B. (1979). A simple technique for nonsurgical embryo transfer in mice. *Lab. Anim. Sci.* **29**, 353-356.
- Montemurro, D. G., and Dukelow, R. H. (1972). "A Stereotaxic Atlas of the Diencephalon and Related Structures of the Mouse." Futura Publishing Company, Mt. Kisco, New York.
- Montgomery, A. (1975). Parabolic reinnervation: Surgical technique and animal care. *Lab. Anim. Sci.* **25**, 491-494.
- Moran, R. E., and Straus, M. J. (1980). A method for establishing prolonged intravenous infusions in mice. *Lab. Anim. Sci.* **30**, 865-867.
- Moreland, A. F., Chairman (1978). "Guide for the Care and Use of Laboratory Animals," DHEW Publ. No. (NIH) 78-23. U.S. Govt. Printing Office, Washington, D.C.
- Morello, N., and Nicholas, J. (1969). A plastic food tube for accurately dispensing powdered diets to mice. *Lab. Anim. Care* **19**, 406-407.
- Mulder, J. B. (1978). Anesthesia in the mouse using a combination of ketamine and promazine. *Lab. Anim. Sci.* **28**, 70-71.
- Mulder, J. B. (1979). A plastic restraining device for rodents. *Lab. Anim. Sci.* **29**, 507-508.
- Mulder, J. B., and Brown, R. V. (1972). An anesthetic unit for small laboratory animals. *Lab. Anim. Sci.* **22**, 422-423.
- Mulder, K. J., and Mulder, J. B. (1979). Ketamine and xylazine anesthesia in the mouse. *VMISAC, Vet. Med. Small Anim. Clin.* **74**, 569-570.
- Murakami, H., and Imai, H. (1975). A digital auto-recorder for measuring the drinking frequency of mice. *Lab. Anim. Sci.* **25**, 634-637.
- Muranyi-Kovacs, I., Rudali, G., and Assa, R. (1977). Mammary carcinogenesis in castrated (C3H x RHH) F₁ male mice bearing ovarian transplants in the ear for variable periods of time. *Eur. J. Cancer* **13**, 1351-1356.
- Murine Virus Diagnostic Laboratory (1978). "Diagnostic Procedures for Viral Infections of Laboratory Rodents." Microbiol. Assoc., Bethesda, Maryland.
- Mylrea, K. C., and Abbrecht, P. H. (1967). An apparatus for tail vein injection in mice. *Lab. Anim. Care* **17**, 602-603.
- Nagasawa, H. (1979). A device for milk collection from mice. *Lab. Anim. Sci.* **29**, 633-635.
- Nakajima, K., and Tsuchiya, S. (1974). Oral respiration in mice induced by artificial obstruction of the nasal passage. *Exp. Anim.* **23**, 225-227 (in Japanese, Engl. abstr.).
- Nakanishi, Y., and Nagasawa, H. (1976). Improved procedure for hypo-

- physectomy of the mouse. *Exp. Anim.* **25**, 13-17 (in Japanese, Engl. abstr.).
- Nashed, N. (1975). A technique for the collection of peritoneal cells from laboratory animals. *Lab. Anim. Sci.* **25**, 225-227.
- Nebert, D. W., and Gelboin, H. V. (1969). The *in vivo* and *in vitro* induction of arylhydrocarbon hydroxylase in mammalian cells of different species, tissues, strains, and development and hormonal states. *Arch. Biochem. Biophys.* **134**, 76-89.
- Nelson, J. B. (1973). Response of mice to *Corynebacterium kutscheri* on footpad injection. *Lab. Anim. Sci.* **23**, 370-372.
- Neudeck, L. D., and Fournier, D. J. (1980). A simple technique for silicone rubber perfusion of the microcirculation of the mouse kidney. *Lab. Anim. Sci.* **30**, 209-211.
- Newman, D. L., and Looker, T. (1972). Simultaneous measurement of the systolic blood pressure and heart rate in the rat by a transcutaneous method. *Lab. Anim.* **6**, 207-211.
- Nickson, J. J., and Barkulis, S. S. (1948). An apparatus to facilitate intravenous injections in the mouse. *Science* **107**, 229-230.
- Nixon, G. A., and Reer, P. J. (1973). A method for preventing oral ingestion of topically applied materials. *Lab. Anim. Sci.* **23**, 423-425.
- Nobunaga, T., Nakamura, K., and Imamichi, T. (1966). A method for intravenous injection and collection of blood from rats and mice without restraint and anesthesia. *Lab. Anim. Care* **16**, 40-49.
- Oda, M., and Miranda, G., Jr. (1976). A simple mouse restrainer. *Lab. Anim. Sci.* **27**, 276-277.
- O'Gara, R. W., and Ards, J. (1961). Intrasplenic transplantation of neonatal thymus. *JNCI, J. Natl. Cancer Inst.* **27**, 277-297.
- Pearson, L. D., Osebold, J. W., and Wagner, P. C. (1971). A device for measuring the volume of footpad swelling from delayed hypersensitivity reactions in mice. *Lab. Anim. Sci.* **21**, 591-593.
- Pilgrim, H. I. (1963). Technique for sampling bone marrow from the living mouse. *Blood* **21**, 241-242.
- Pilgrim, H. I. (1969). A lightweight autoclavable free-flow germfree mouse isolator. *Lab. Anim. Care* **19**, 117-120.
- Pinkerton, W., and Webber, M. (1964). A method of injecting small laboratory animals by the ophthalmic plexus route. *Proc. Soc. Exp. Biol. Med.* **116**, 959-961.
- Pope, R. S., and Murphy, E. D. (1960). Survival of strain 129 dystrophic mice in parabiosis. *Am. J. Physiol.* **199**, 1097-1100.
- Port, C. D., Garvin, P. J., Ganote, C. E., and Sawyer, D. C. (1978). Pathologic changes induced by an euthanasia agent. *Lab. Anim. Sci.* **28**, 448-450.
- Postnikova, Z. A. (1960). Method of intracardiac injection of newborn mice and rats. *Folia Biol. (Prague)* **6**, 59-60.
- Prehn, R. T., and Karnik, V. (1979). Differential susceptibility of the axilla and groin of the mouse to chemical carcinogenesis. *Nature (London)* **279**, 431-433.
- Price, H. L. (1971). The pharmacodynamics of thiobarbiturates. In "Textbook of Veterinary Anesthesia" (L. R. Soma, ed.), pp. 105-110. Williams & Wilkins, Baltimore, Maryland.
- Punyashtiti, K., and Finkelstein, R. A. (1971). Enteropathogenicity of *Escherichia coli*. I. Evaluation of mouse intestinal loops. *Infect. Immun.* **4**, 473-478.
- Rauch, H. (1952). Strain differences in liver patterns in mice. *Genetics* **37**, 617.
- Rhodes, M. L., and Patterson, C. E. (1979). Chronic intravenous infusion in the rat: A nonsurgical approach. *Lab. Anim. Sci.* **29**, 82-84.
- Richards, A. G., Simonson, E., and Visscher, M. B. (1953). Electrocardiogram and phonogram of adult and newborn mice in normal conditions and under the effect of cooling, hypoxia and potassium. *Am. J. Physiol.* **174**, 293-298.
- Riley, V. (1960). Adaptation of orbital bleeding technique to rapid serial blood studies. *Proc. Soc. Exp. Biol. Med.* **104**, 751-754.
- Robertson, G. G. (1942a). An analysis of the development of the homozygous yellow mouse embryos. *J. Exp. Zool.* **89**, 197-225.
- Robertson, G. G. (1942b). Ovarian transplantation in the house mouse. *Proc. Soc. Exp. Biol. Med.* **44**, 302-304.
- Roerig, D. L., Hasegawa, A. T., and Wang, R. I. H. (1980). Rat restrainer for separation and collection of urine and feces. *Lab. Anim. Sci.* **30**, 549-551.
- Rucklidge, G. J., and McKenzie, J. D. (1980). A new metabolism cage suitable for the study of mice. *Lab. Anim.* **14**, 213-216.
- Russell, E. A., Peguese, E. D., and Charlton, W. T. (1979). Subcutaneous implants: Dental researchers develop simplified technique. *Lab. Anim. (New York)* **8**, 36-37.
- Russell, W. L., and Hurst, J. G. (1945). Pure strain mice born to hybrid mothers following ovarian transplantation. *Proc. Natl. Acad. Sci. U.S.A.* **31**, 267-273.
- Ryer, F. H., and Walker, D. W. (1971). An anal cup for rats in metabolic studies involving radioactive materials. *Lab. Anim. Sci.* **21**, 942-943.
- Saito, T. R., and Takahashi, K. W. (1977). A simple operational method on removal of olfactory bulbs of small rodents. *Exp. Anim.* **26**, 131-137 (in Japanese, Engl. abstr.).
- Saito, T. R., and Takahashi, K. W. (1979). Structural outline of drinking behavior activity monitor using touch limit switch for small laboratory animals. *Exp. Anim.* **28**, 405-407 (in Japanese, Engl. abstr.).
- Sakaki, K., Tanaka, K., and Hirasawa, K. (1961). Hematological comparison of the mouse blood taken from the eye and the tail. *Exp. Anim.* **10**, 14-19 (in Japanese, Engl. abstr.).
- Sakita, M., Nishimura, Y., Takenaka, T., Kojima, O., Nishioka, B., Fujita, Y., and Majima, S. (1979). Regional lymphadenectomy and tumor curability in C3H/He mice transplanted with MH 134. *Tohoku J. Exp. Med.* **127**, 133-141.
- Sauberman, A. J., Gallagher, M. L., and Hedley-Whyte, J. (1974). Uptake, distribution and anesthetic effect of pentobarbital-2-¹⁴C after intravenous injection into mice. *Anesthesiology* **40**, 41-51.
- Schiff, L. J., Shefner, A. M., Barbera, P. W., and Pooley, S. M. (1974). The use of BSVR/SrCr mice for detection of murine strains of toxigenic *Escherichia coli*. *Lab. Anim. Sci.* **24**, 752-756.
- Schoenborne, B. M., Schrader, R. E., and Canolty, N. L. (1977). Tattooing newborn mice and rats for identification. *Lab. Anim. Sci.* **27**, 110.
- Scott, J. V., and Dziuk, P. J. (1959). Evaluation of the electroejaculation technique and the spermatozoa thus obtained from rats, mice and guinea pigs. *Anat. Rec.* **133**, 655-664.
- Seamer, J., and Peto, S. (1969). A method of assessment of central nervous function in mice with viral encephalomyelitis. *Lab. Anim.* **3**, 129-140.
- Searle, A. G. (1959). Hereditary absence of spleen in the mouse. *Nature (London)* **184**, 1419-1420.
- Sedlacek, R. S., Milas, L., and Marshall, N. R. (1970). An improved technique for skin grafting in mice. *Lab. Anim. Care* **20**, 747-748.
- Seibert, K., and Pollard, M. (1973). A simple method for skin grafting in germfree mice. *Lab. Anim. Sci.* **23**, 256-258.
- Shani, J., Givant, Y., and Sulman, F. G. (1970). A capsule-feeder for small laboratory animals. *Lab. Anim. Care* **20**, 1154-1155.
- Shrewsbury, M. M. (1958). Rate of flow and cell count of thoracic duct lymph in the mouse. *Proc. Soc. Exp. Biol. Med.* **99**, 53-54.
- Sidman, R. L., Angevine, J. B., Jr., and Pierce, E. T. (1971). "Atlas of the Mouse Brain and Spinal Cord." Harvard Univ. Press, Cambridge, Massachusetts.
- Siegler, R., and Rich, M. A. (1963a). Unilateral histogenesis of AKR thymic lymphoma. *Cancer Res.* **23**, 1669-1678.
- Siegler, R., and Rich, M. A. (1963b). Artificial respiration in mice during

- thoracic surgery: A simple, inexpensive technique. *Proc. Soc. Exp. Biol. Med.* **114**, 511-513.
- Sigdestad, C. P., Connor, A. M., Sharp, J. B., Jr., and Ackerman, M. R. (1974). Evaluating feeding cycles of small rodents. *Lab. Anim. Sci.* **24**, 919-921.
- Silmsner, C., Bond, C. R., and Eichwald, E. J. (1955). The technique of mouse skin grafting. *Transplant. Bull.* **2**, 38-39.
- Silva, M., and Gras, J. (1979). Conditions for greater survival of neonatally thymectomized Swiss mice (author's transl.). *Rev. Esp. Fisiol.* **35**, 85-87 (in Spanish, Engl. abstr.).
- Simmons, M. L., and Brick, J. O. (1970). "The Laboratory Mouse—Selection and Management." Prentice-Hall, Englewood Cliffs, New Jersey.
- Sjödin, K., Dalmasso, A. P., Smith, J. M., and Martinez, C. (1963). Thymectomy of newborn and adult mice. *Transplantation* **1**, 521-525.
- Skoskiewicz, M., Chase, C., Winn, H. J., and Russell, P. S. (1973). Kidney transplant between mice of graded immunogenetic diversity. *Transplant. Proc.* **5**, 721-725.
- Smith, D. M., Goddard, K. M., Wilson, R. B., and Newberne, P. M. (1973). An apparatus for anesthetizing small laboratory rodents. *Lab. Anim. Sci.* **23**, 869-871.
- Smith, K. W. (1965). Female genital tract. In "Canine Surgery" (J. Archibald, ed.), pp. 641-676. Am. Vet. Publ., Inc., Santa Barbara, California.
- Smith, P. E. (1930). Hypophysectomy and a replacement therapy in the rat. *Am. J. Anat.* **45**, 205-273.
- Snell, G. D., and Hummel, K. P. (1975). Bibliography of techniques. In "Biology of the Laboratory Mouse" (E. L. Green, ed.), 2nd ed., pp. 655-661. Dover, New York.
- Snell, G. D., and Stevens, L. C. (1975). Early embryology. In "Biology of the Laboratory Mouse" (E. L. Green, ed.), pp. 205-246. Dover, New York.
- Snell, G. D., Hummel, K. P., and Abelmann, W. H. (1944). A technique for the artificial insemination of mice. *Anat. Rec.* **90**, 243-253.
- Southard, J. L., Wolfe, H. G., and Russell, E. S. (1965). Artificial insemination of dystrophic mice with mixtures of spermatozoa. *Nature (London)* **208**, 1126-1127.
- Spyker, J. M., Sparber, S. B., and Goldberg, A. M. (1972). Subtle consequences of methylmercury exposure: Behavioral deviations in offspring of treated mothers. *Science* **177**, 621-622.
- Stevens, L. C. (1957). A modification of Robertson's technique of homotopic ovarian transplantation in mice. *Transplant. Bull.* **4**, 106-107.
- Stevens, L. C. (1964). Experimental production of testicular teratomas in mice. *Proc. Natl. Acad. Sci. U.S.A.* **52**, 654-661.
- Stoltz, D. R., and Bendall, R. D. (1975). A simple technique for repeated collection of blood samples from mice. *Lab. Anim. Sci.* **25**, 353-354.
- Stone, S. H. (1954). Method for obtaining venous blood from the orbital sinus of the rat or mouse. *Science* **119**, 100.
- Stunkard, J. A., Schmidt, J. P., and Cordaro, J. T. (1971). Consumption of oxytetracycline in drinking water by healthy mice. *Lab. Anim. Sci.* **21**, 121-122.
- Sugano, S., and Nomura, S. (1963a). Observation and recording of heart, respiratory movement, arterial blood pressure and body temperature of mice. II. A method measuring carotid blood pressure in mice. *Exp. Anim.* **12**, 1-5 (in Japanese, Engl. abstr.).
- Sugano, S., and Nomura, S. (1963b). Observation and recording of heart, respiratory movement, arterial blood pressure and body temperature in mice. III. A method of recording respiratory movement in mice. *Exp. Anim.* **12**, 89-94 (in Japanese, Engl. abstr.).
- Sugano, S., and Nomura, S. (1963c). Observations and recording of heart rate, respiratory movement, arterial blood pressure and body temperature in mice. IV. On simultaneous and polygraphic recording of heart beat, respiratory movement, arterial blood pressure and rectal temperature in mice aiming at their graphic treatment. *Exp. Anim.* **12**, 123-129 (in Japanese, Engl. abstr.).
- Sundberg, R. D., and Hodgson, R. E. (1949). Aspiration of bone marrow in laboratory animals. *Blood* **4**, 557-561.
- Taber, R., and Irwin, S. (1969). Anesthesia in the mouse. *Fed. Proc., Fed. Am. Soc. Exp. Biol.* **28**, 1528-1532.
- Takeshima, T., and Toyoda, Y. (1977). Artificial insemination in the mouse with special reference to the effect of sperm numbers on the conception rate and litter size. *Exp. Anim.* **26**, 317-322.
- Talamantes, F., Guzman, R., and Lopez, J. (1977). Intraocular ovarian iso-grafts in male mice and their response to human placental lactogen. *J. Endocrinol.* **75**, 333-334.
- Talmage, D. W., and Dart, G. A. (1978). Effect of oxygen pressure during culture on survival of mouse thyroid allografts. *Science* **200**, 1066-1067.
- Tanioka, Y., Tsukada, M., and Esoki, K. (1973). A technique of ovarian transplantation in mice. *Exp. Anim.* **22**, 15-20.
- Tarin, D., and Sturdee, A. (1972). Surgical anesthesia of mice: Evaluation of tribromoethanol, ether, halothane and methoxyflurane and development of a reliable technique. *Lab. Anim.* **6**, 79-84.
- Thomas, F. (1938). A technique for hypophysectomy of the mouse. *Endocrinology* **23**, 99-102.
- Thompson, J. S. (1963). Transplantation of whole mammary glands in mice. *Transplantation* **1**, 526-534.
- Toya, R. E., and Clapp, N. K. (1972). Estimation of water consumption by individual mice caged in groups. *Lab. Anim. Sci.* **22**, 709-711.
- Uchida, H., Mori, A., and Goto, N. (1973). A measurement of body volume of the mouse. *Exp. Anim.* **22**, 267-270 (in Japanese, Engl. abstr.).
- Ueda, H., Amano, H., Shiomi, H., and Takagi, H. (1979). Comparison of the analgesic effects of various opioid peptides by a newly devised intracisternal injection technique in conscious mice. *Eur. J. Pharmacol.* **56**, 265-268.
- Van Es, A. A. (1972). A technique for massive skin grafting in rats. *Lab. Anim. Sci.* **22**, 404-406.
- Van Nimwegen, C., Van Eijnsbergen B., Boter, J., and Mullink, J. W. M. A. (1973). A simple device for indirect measurement of blood pressure in mice. *Lab. Anim.* **7**, 73-84.
- Varnum, D. (1981). The Jackson Laboratory, Bar Harbor, Maine (personal communication).
- Verstraete, A. P. (1973). Comparison of techniques for taking liver and lung samples from small rodents for bacteriological cultures. *Lab. Anim.* **7**, 189-193.
- Vesell, E. S. (1968). Factors altering the responses of mice to hexobarbital. *Pharmacology* **1**, 81-97.
- Vesell, E. S., Lang, C. M., White, W. J., Passanati, G. T., Hill, R. N., Clemens, T. L., Liu, D. K., and Johnson, W. D. (1976). Environmental and genetic factors affecting the response of laboratory animals to drugs. *Fed. Proc., Fed. Am. Soc. Exp. Biol.* **35**, 1125-1132.
- Walden, N. B. (1978). Effective sedation of rabbits, guinea pigs, rats and mice with a mixture of fentanyl and droperidol. *Aust. Vet. J.* **54**, 538-540.
- Wallace, M. E. (1968). A chute for the transference of hyperactive mice during cage cleaning procedures. *Lab. Anim. Care* **18**, 200-205.
- Waynforth, H. B., and Parkin, R. (1969). Sublingual vein injection in rodents. *Lab. Anim.* **3**, 35-37.
- Waynforth, H. B., Holsman, J. W., and Parkin, R. (1977). A simple device to facilitate intragastric infusion per os in the conscious rat. *Lab. Anim.* **11**, 129-131.
- Weeks, J. R., and Jones, J. A. (1960). Routine direct measurement of arterial pressure in unanesthetized rats. *Proc. Soc. Exp. Biol. Med.* **104**, 646-648.
- Weisbroth, S. H., and Fudens, J. H. (1972). Use of ketamine hydrochloride as

- an anesthetic in laboratory rabbits, rats, mice and guinea pigs. *Lab. Anim. Sci.* **22**, 904-906.
- Weksler, M. E., Bodine, S., and Rommer, J. (1974). Response of lymphocytes to plant lectins. I. A thymic-dependent lymphoid population response to pokeweed mitogen. *Immunology* **26**, 281-290.
- West, J. D., Frels, W. I., Papaioannou, V. E., Karr, J. P., and Chapman, V. M. (1977). Development of interspecific hybrids of *Mus*. *J. Embryol. Exp. Morphol.* **41**, 233-243.
- West, R. W., Stanley, J. W., and Newport, G. D. (1978). Single-mouse urine collection and pH monitoring system. *Lab. Anim. Sci.* **28**, 343-345.
- Westfall, B. A., Boulos, B. M., Shields, J. L., and Garb, S. (1964). Sex differences in pentobarbital sensitivity in mice. *Proc. Soc. Exp. Biol. Med.* **115**, 509-510.
- Wharton, R. S., Sievenpiper, T. S., and Mazze, R. I. (1980). Development of toxicity of methoxyflurane in mice. *Anesth. Analg. (Cleveland)* **59**, 421-425.
- Whitcher, C. E., and Rock, J. C. (1978). "Control of Occupational Exposure to Inhalational Anesthetics—Current Status." USAF Occupational and Environmental Health Laboratory Technical Reprint. Aerospace Medical Subdivision, Brooks Air Force Base, Texas.
- Wolfe, H. G. (1967). Artificial insemination of the laboratory mouse (*Mus musculus*). *Lab. Anim. Care* **17**, 426-432.
- Woolley, G. W., and Little, C. C. (1945). The incidence of adrenal cortical carcinoma in gonadectomized female mice of the extreme dilution strain. I. Observations on the adrenal cortex. *Cancer Res.* **5**, 193-202.
- Yngner, T. (1975). A device for sampling liver tissue from unanesthetized mice. *Lab. Anim. Sci.* **25**, 647-648.
- Young, L., and Chambers, T. (1973). A mouse bleeding technique yielding consistent volume with minimal hemolysis. *Lab. Anim. Sci.* **23**, 428-430.