



US005566353A

United States Patent [19]

[11] Patent Number: **5,566,353**

Cho et al.

[45] Date of Patent: **Oct. 15, 1996**

- [54] **POINT OF PURCHASE VIDEO DISTRIBUTION SYSTEM**
- [75] Inventors: **Nack Y. Cho**, Mill Valley; **Jerry E. Magilton, Jr.**, San Francisco, both of Calif.
- [73] Assignee: **Bylon Company Limited**, Kowloon, Hong Kong
- [21] Appl. No.: **301,320**
- [22] Filed: **Sep. 6, 1994**
- [51] Int. Cl.⁶ **H04N 7/00**
- [52] U.S. Cl. **455/2; 348/2; 348/13; 455/3.1; 455/6.3**
- [58] **Field of Search** 455/3.1, 3.2, 4.1, 455/4.2, 5.1, 6.1, 6.3, 11.1, 12.1, 13.1, 13.3, 7, 14, 15, 16, 18, 19, 2, 31.1, 32.1, 33.1, 39, 49.1, 53.1, 66; 345/2; 348/2, 6, 12, 13, 61, 552; H04N 7/00, 7/10, 7/20, 7/22

5,155,591 10/1992 Wachob .

FOREIGN PATENT DOCUMENTS

0624040A2	11/1994	European Pat. Off.	H04N 7/173
2613520	10/1988	France	345/2
3534652	4/1987	Germany	345/2
62-36932	2/1987	Japan .	
62-235835	10/1987	Japan .	
63-276337	11/1988	Japan .	
1-97028	4/1989	Japan .	
1-103335	4/1989	Japan .	
1-220925	9/1989	Japan .	
2-295240	12/1990	Japan .	
3-70438	3/1991	Japan .	
3-117123	5/1991	Japan .	
3-145828	6/1991	Japan .	
3-196726	8/1991	Japan .	
WO94/03995	2/1994	WIPO .	
WO94/10775	5/1994	WIPO	H04K 1/02
WO94/14283	6/1994	WIPO	H04N 7/163

- [56] **References Cited**
- U.S. PATENT DOCUMENTS
- Re. 31,735 11/1984 Davidson .
- 4,028,733 6/1977 Ulicki .
- 4,630,108 12/1986 Gomersall 358/84
- 4,720,873 1/1988 Goodman et al. .
- 4,724,491 2/1988 Lambert .
- 4,725,886 2/1988 Galumbeck et al. .
- 4,814,883 3/1989 Perine et al. .
- 4,916,539 4/1990 Galumbeck .
- 4,937,821 6/1990 Boulton .
- 5,029,014 7/1991 Lindstrom .
- 5,099,319 3/1992 Esch et al. .
- 5,119,188 7/1992 McCalley et al. .
- 5,132,992 7/1992 Yurt et al. .
- 5,133,081 7/1992 Mayo 455/66
- 5,151,782 9/1992 Ferraro .

Primary Examiner—David E. Harvey
Attorney, Agent, or Firm—Townsend and Townsend and Crew LLP

[57] ABSTRACT

A video distribution system for full motion video media, usually in the form of advertisements, that allows video programs to be transmitted from a distribution center to a multitude of receiving sites, typically retail stores, dispersed over a wide geographic area. Video program segments are transmitted from the distribution site (100) and received at the receiving sites (254). Television monitors located at selected points in the receiving sites display the video program segments to an audience, which usually will include shoppers in the course of shopping. The invention allows users located in the distribution center to customize the video programs for particular target audiences or markets, such that the series of programs played in one receiving site could be quite different from that played in another.

23 Claims, 14 Drawing Sheets

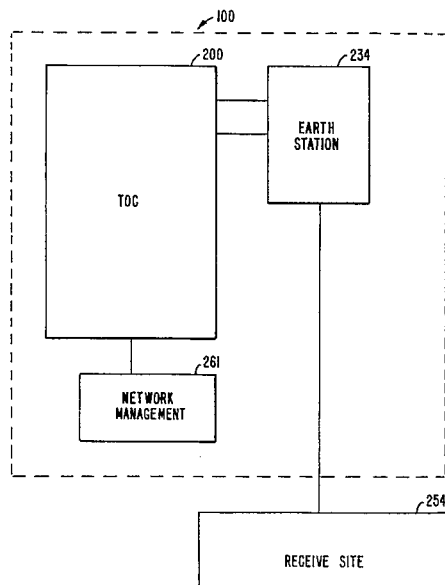

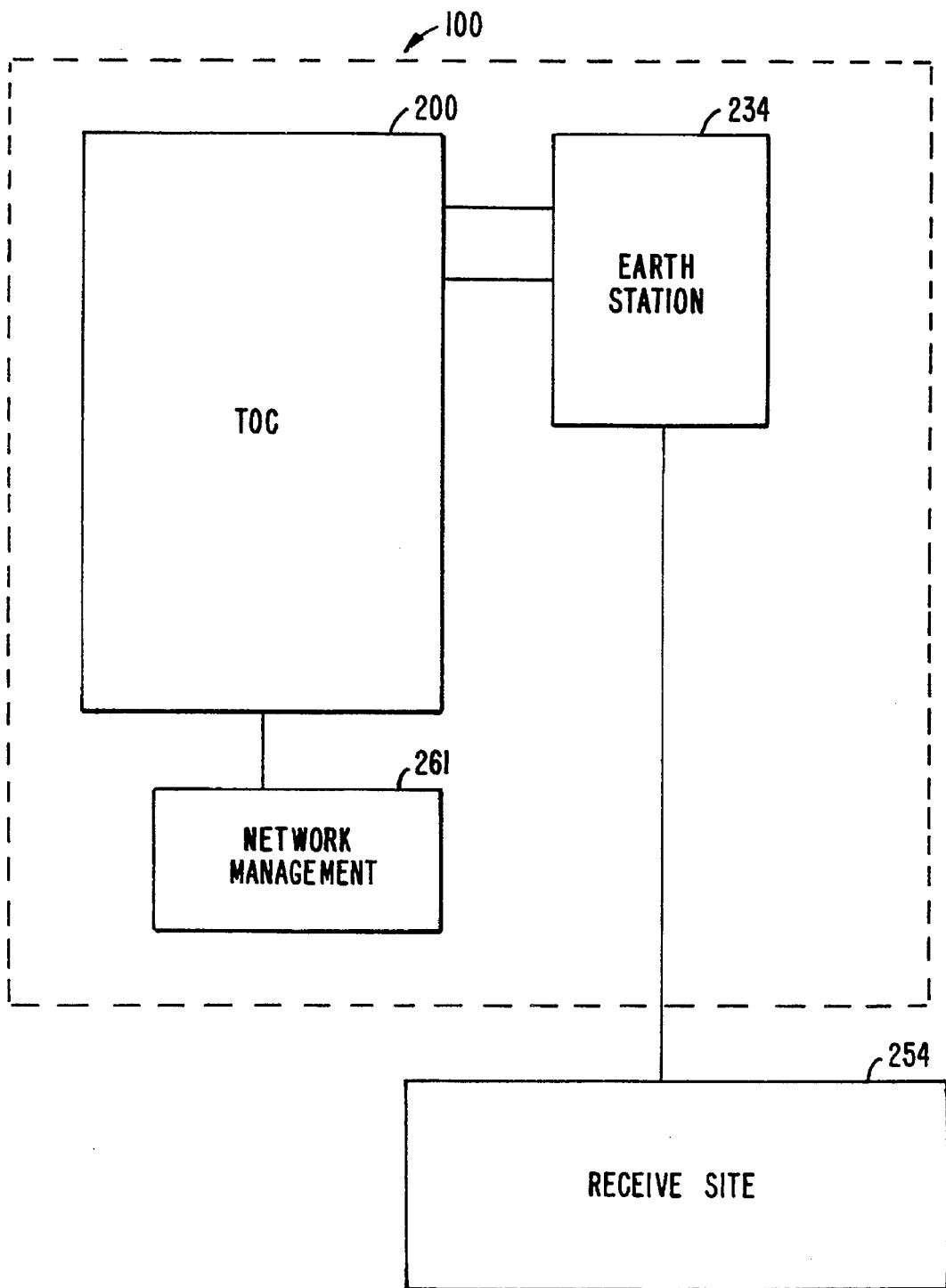

FIG. 1.

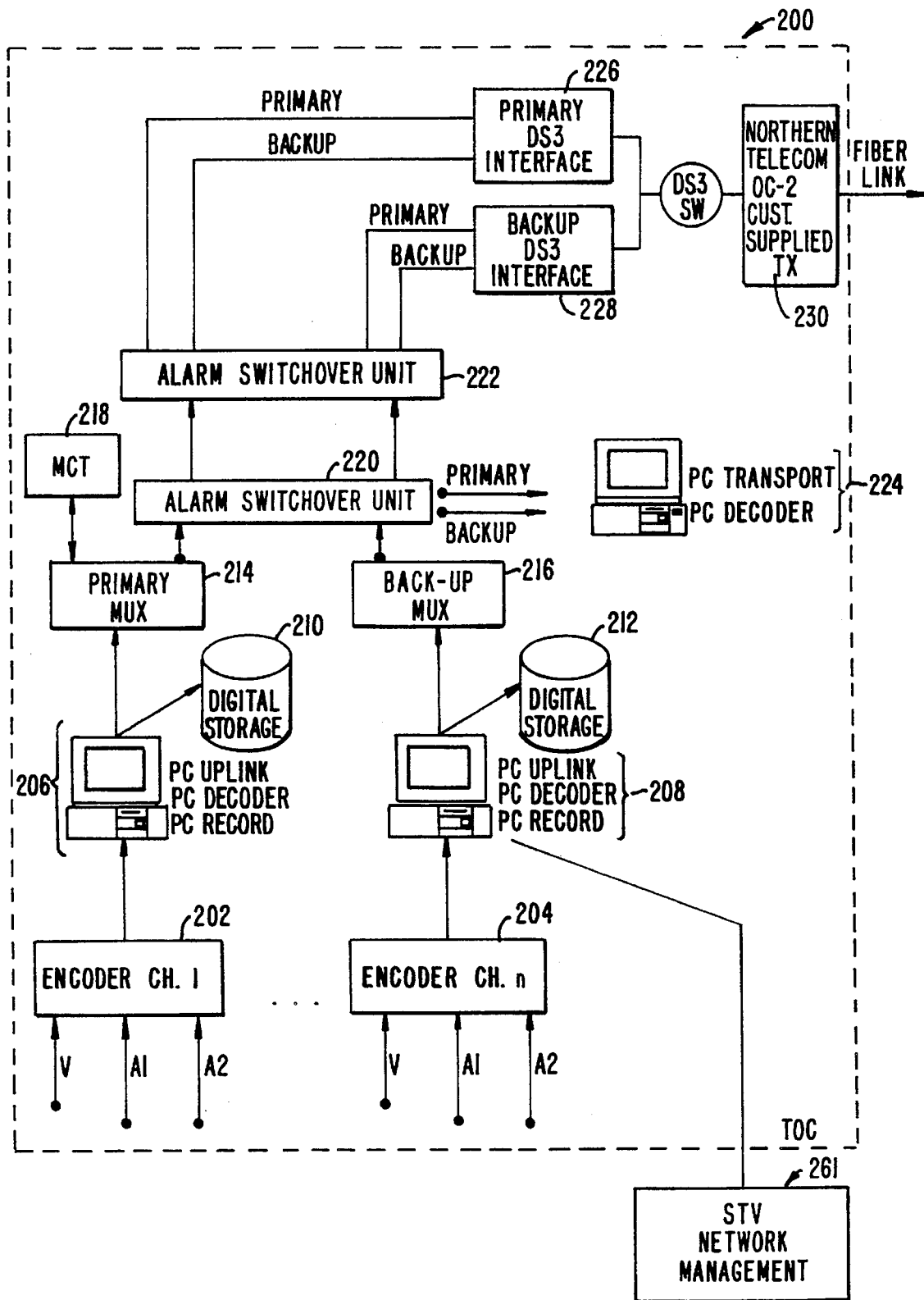

FIG. 2.

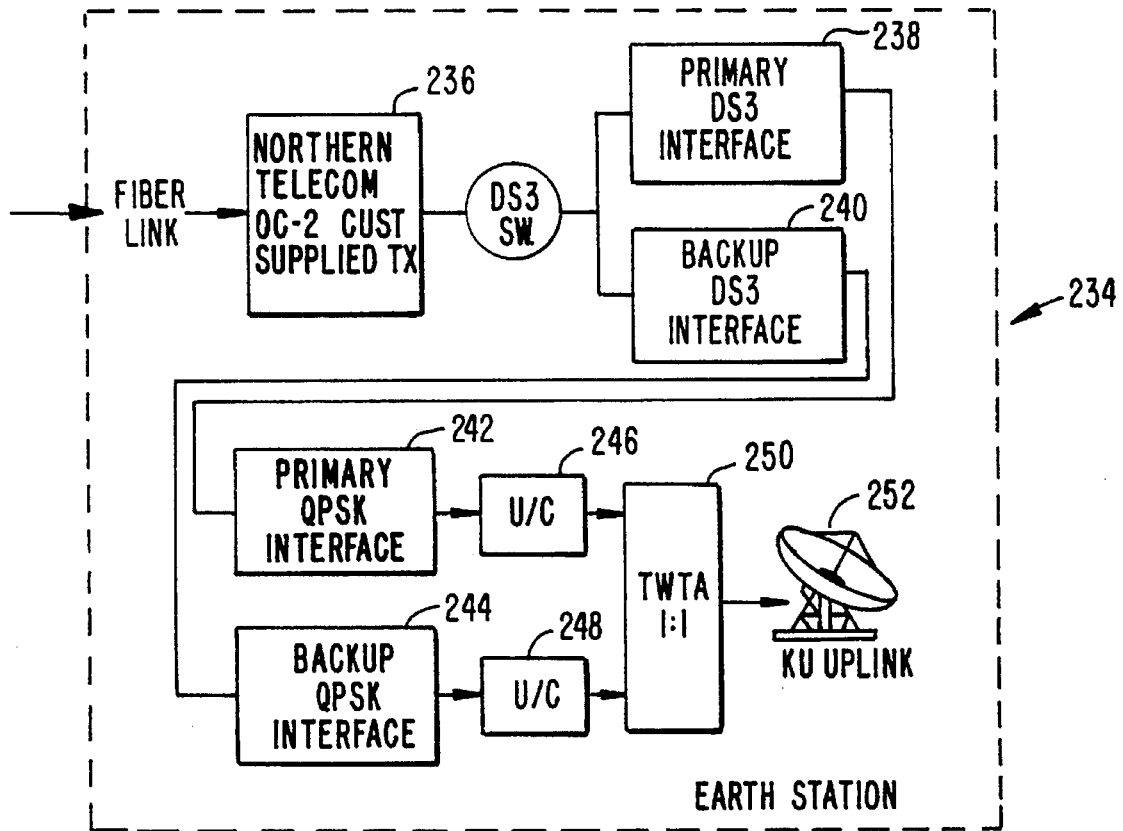

FIG. 3.

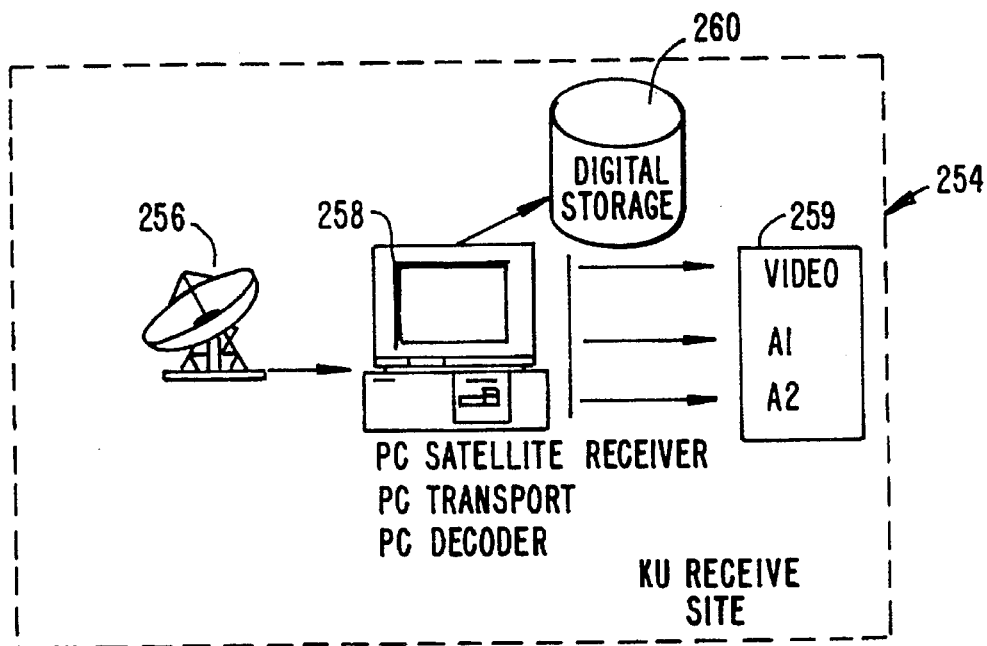

FIG. 4.

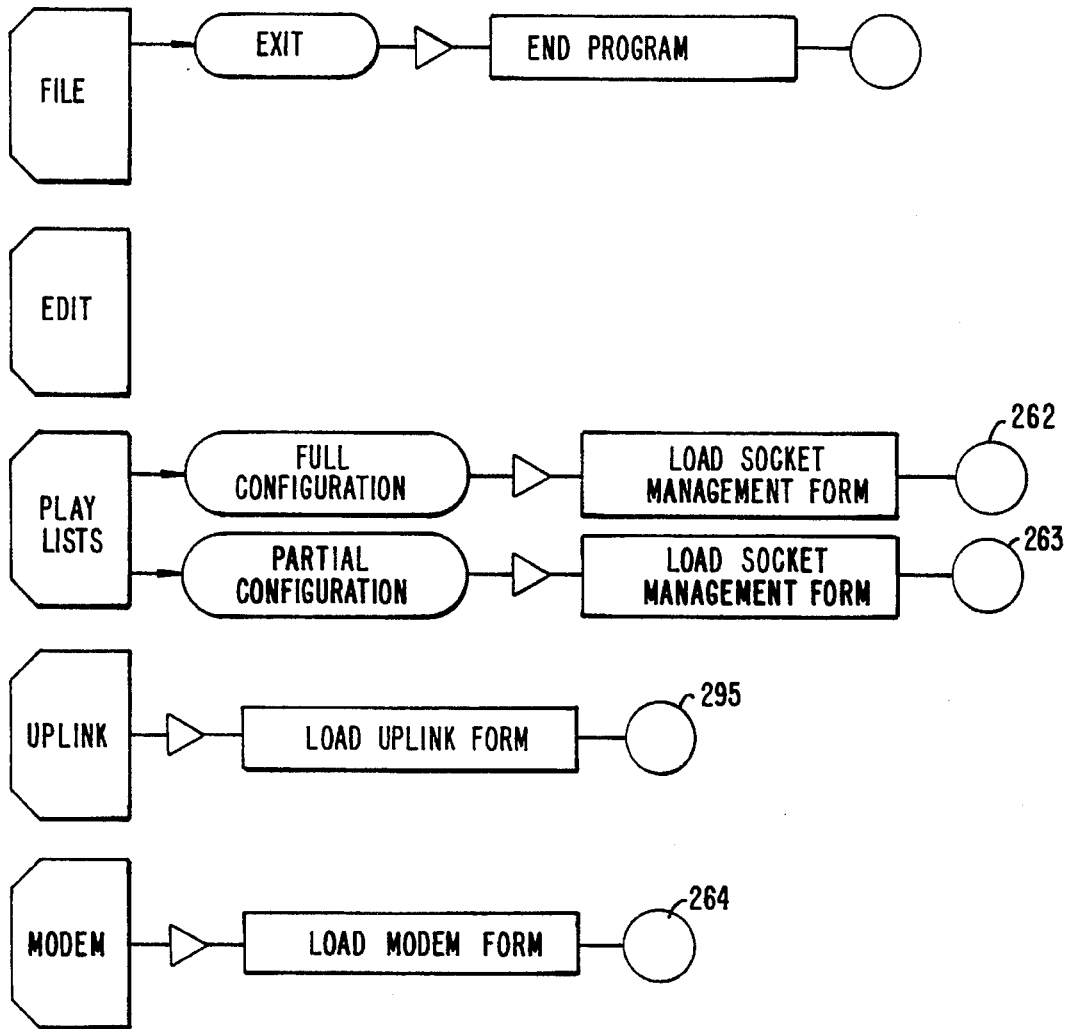

FIG. 5.

Explore Litigation Insights

Docket Alarm provides insights to develop a more informed litigation strategy and the peace of mind of knowing you're on top of things.

Real-Time Litigation Alerts



Keep your litigation team up-to-date with **real-time alerts** and advanced team management tools built for the enterprise, all while greatly reducing PACER spend.

Our comprehensive service means we can handle Federal, State, and Administrative courts across the country.

Advanced Docket Research



With over 230 million records, Docket Alarm's cloud-native docket research platform finds what other services can't. Coverage includes Federal, State, plus PTAB, TTAB, ITC and NLRB decisions, all in one place.

Identify arguments that have been successful in the past with full text, pinpoint searching. Link to case law cited within any court document via Fastcase.

Analytics At Your Fingertips



Learn what happened the last time a particular judge, opposing counsel or company faced cases similar to yours.

Advanced out-of-the-box PTAB and TTAB analytics are always at your fingertips.

API

Docket Alarm offers a powerful API (application programming interface) to developers that want to integrate case filings into their apps.

LAW FIRMS

Build custom dashboards for your attorneys and clients with live data direct from the court.

Automate many repetitive legal tasks like conflict checks, document management, and marketing.

FINANCIAL INSTITUTIONS

Litigation and bankruptcy checks for companies and debtors.

E-DISCOVERY AND LEGAL VENDORS

Sync your system to PACER to automate legal marketing.