

UNITED STATES PATENT AND TRADEMARK OFFICE

BEFORE THE PATENT TRIAL AND APPEAL BOARD

TALARI NETWORKS, INC.,
Petitioner,

v.

FATPIPE NETWORKS INDIA LIMITED,
Patent Owner.

Case IPR2016-00976
Patent 6,775,235 B2

Before STACEY G. WHITE, MICHELLE N. WORMMEESTER, and
CHRISTA P. ZADO, *Administrative Patent Judges*.

WHITE, *Administrative Patent Judge*.

FINAL WRITTEN DECISION
35 U.S.C. § 318(a) and 37 C.F.R. § 42.73

I. INTRODUCTION

A. Background

Talari Networks, Inc. (“Petitioner”) filed a Petition (Paper 1, “Pet.”) seeking to institute an *inter partes* review of claims 4, 5, 7–15, and 19 of U.S. Patent No. 6,775,235 B2 (Ex. 1001, “the ’235 patent”) pursuant to 35 U.S.C. §§ 311–319. FatPipe Networks India Limited. (“Patent Owner”) filed a Preliminary Response. Paper 6 (“Prelim. Resp.”). Based on our review of these submissions, we instituted *inter partes* review of claims 4, 5, 7–15, and 19 on the following specific grounds:

Reference(s)	Basis	Claims Challenged
Karol ¹	§ 102	4, 5, 7–11, 14, and 19
Karol	§ 103	4, 5, 7–15, and 19
Karol and Stallings ²	§ 103	5, 11–15, and 19

Paper 7 (“Dec.”), 22. Patent Owner filed a Patent Owner’s Response (Paper 22, “PO Resp.”), and Petitioner filed a Reply (Paper 26, “Reply”). An oral hearing was held on August 14, 2017. Paper 31 (“Tr.”).

We have jurisdiction under 35 U.S.C. § 6. This Final Written Decision is issued pursuant to 35 U.S.C. § 318(a) and 37 C.F.R. § 42.73. For the reasons discussed below, Petitioner has demonstrated by a preponderance of the evidence that claims 4, 5, and 7–15 of the ’235 patent are unpatentable. Petitioner has not meet its burden to establish the unpatentability of claim 19.

¹ U.S. Patent No. 6,628,617 B1 (“Karol,” Ex. 1006).

² William Stallings, *Data and Computer Communications*, Prentice-Hall, 5th Ed, 1997, ISBN-81-203-1240-6 (“Stallings,” Ex. 1011).

B. Related Proceedings

The parties inform us that *FatPipe, Inc. v. Talari Networks, Inc.*, No. 5:16-CV-54-BO (E.D.N.C.) and *FatPipe, Inc. v. Viptela, Inc.*, No. DED-1-16-cv-00182 (D. Del.), may be impacted by this proceeding. Pet. 1; Paper 30, 2–3. In addition, Petitioner has a pending petition for *inter partes* review of a related patent, U.S. Patent No. 7,406,048 B2 (“the ’048 patent”) (IPR2016-00977). Pet. 2. Viptela, Inc. and Cisco Systems, Inc. also have filed petitions seeking *inter partes* review of various claims of the ’235 and ’048 patents. Paper 30, 3.

C. The ’235 Patent

The ’235 patent describes a system and method for communicating using two or more disparate networks in parallel. Ex. 1001, Abstract. For example, an embodiment of this system could be composed of a virtual private network (“VPN”) in parallel with a frame relay network. *Id.* at 1:19–24. These parallel networks back each other up in case of failure and when both networks are operational their loads are balanced between the parallel networks. *Id.* at Abstract. An embodiment of this system is depicted in Figure 10, which is shown below.

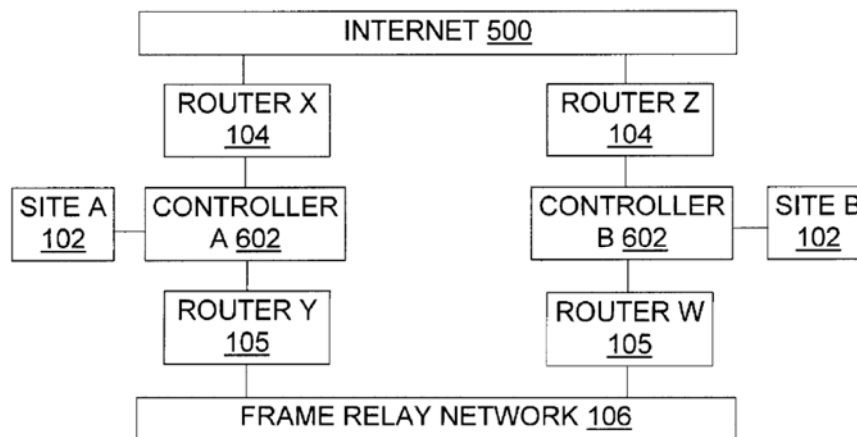

Fig. 10

Figure 10 depicts an example of the network topology described in the '235 patent. *Id.* at 8:29–30. Two sites 102 transmit and/or receive data from one another. *Id.* at 2:38–40. These sites are connected by two disparate networks, Internet 500 and frame relay network 106. *Id.* at 8:30–32. Each location has frame relay router 105 and Internet router 104. *Id.* at 8:32–33. “Access to the disparate networks at site A and site B is through an inventive controller 602 at each site.” *Id.* at 6:34–36. Controller 602 “allows load-balancing, redundancy, or other criteria to be used dynamically, on a granularity as fine as packet-by-packet, to direct packets to an Internet router and/or frame relay/point-to-point router according to the criteria.” *Id.* at 9:12–17.

Figure 7 of the '235 patent is reproduced below.

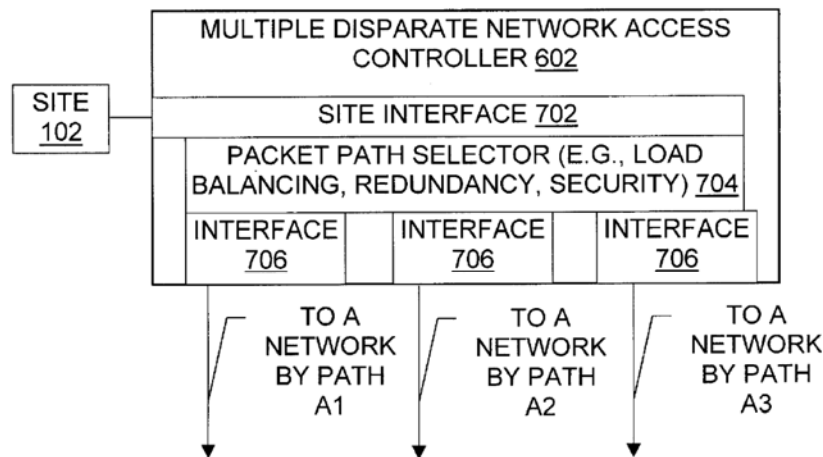

Fig. 7

Figure 7 depicts controller 602. *Id.* at 10:59–60. Controller 602 is connected to site 102 via site interface 702. *Id.* at 10:60–63. Packet path selector 704 is hardware or software that determines which path a given packet is to travel. *Id.* at 11:2–6. The criteria used to determine which path a packet travels may be based on concerns such as redundancy,

load-balancing, or security. *Id.* at 11:9–63. Controller 602 also has two or more network interfaces 706 (at least one per each network for which controller 602 controls access). *Id.* at 11:64–67.

D. Illustrative Claim

As noted above, we instituted review of claims 4, 5, 7–15, and 19 of the '235 patent, of which claims 4, 5, and 19 are independent. Claim 5 is illustrative of the challenged claims and is reproduced below:

5. A method for combining connections for access to multiple parallel disparate networks, the method comprising the steps of:
 - obtaining at least two known location address ranges which have associated networks;
 - obtaining topology information which specifies associated networks that provide, when working, connectivity between a current location and at least one destination location;
 - receiving at the current location a packet which identifies a particular destination location by specifying a destination address for the destination location;
 - determining whether the destination address lies within a known location address range;
 - selecting a network path from among paths to disparate associated networks, said networks being in parallel at the current location, each of said networks specified in the topology information as capable of providing connectivity between the current location and the destination location;
 - forwarding the packet on the selected network path.

II. CLAIM CONSTRUCTION

In an *inter partes* review, “[a] claim in an unexpired patent shall be given its broadest reasonable construction in light of the specification of the patent in which it appears.” 37 C.F.R. § 42.100(b). Under this standard, we

Explore Litigation Insights

Docket Alarm provides insights to develop a more informed litigation strategy and the peace of mind of knowing you're on top of things.

Real-Time Litigation Alerts



Keep your litigation team up-to-date with **real-time alerts** and advanced team management tools built for the enterprise, all while greatly reducing PACER spend.

Our comprehensive service means we can handle Federal, State, and Administrative courts across the country.

Advanced Docket Research



With over 230 million records, Docket Alarm's cloud-native docket research platform finds what other services can't. Coverage includes Federal, State, plus PTAB, TTAB, ITC and NLRB decisions, all in one place.

Identify arguments that have been successful in the past with full text, pinpoint searching. Link to case law cited within any court document via Fastcase.

Analytics At Your Fingertips



Learn what happened the last time a particular judge, opposing counsel or company faced cases similar to yours.

Advanced out-of-the-box PTAB and TTAB analytics are always at your fingertips.

API

Docket Alarm offers a powerful API (application programming interface) to developers that want to integrate case filings into their apps.

LAW FIRMS

Build custom dashboards for your attorneys and clients with live data direct from the court.

Automate many repetitive legal tasks like conflict checks, document management, and marketing.

FINANCIAL INSTITUTIONS

Litigation and bankruptcy checks for companies and debtors.

E-DISCOVERY AND LEGAL VENDORS

Sync your system to PACER to automate legal marketing.