



US006326301B1

(12) **United States Patent**
Venkatesan et al.

(10) **Patent No.:** **US 6,326,301 B1**
(45) **Date of Patent:** **Dec. 4, 2001**

(54) **METHOD FOR FORMING A DUAL INLAID COPPER INTERCONNECT STRUCTURE**

(75) Inventors: **Suresh Venkatesan; Bradley P. Smith; Mohammed Rabiul Islam**, all of Austin, TX (US)

(73) Assignee: **Motorola, Inc.**, Schaumburg, IL (US)

(*) Notice: Subject to any disclaimer, the term of this patent is extended or adjusted under 35 U.S.C. 154(b) by 0 days.

(21) Appl. No.: **09/352,134**

(22) Filed: **Jul. 13, 1999**

(51) Int. Cl.⁷ **H01L 21/4763; H01L 21/44**

(52) U.S. Cl. **438/638; 438/618; 438/634; 438/687; 438/970**

(58) Field of Search **438/618, 638, 438/634, 620, 637, 671, 687, 970**

(56) **References Cited**

U.S. PATENT DOCUMENTS

6,077,768 *	6/2000	Ong et al.	438/622
6,100,184 *	8/2000	Zhao et al.	438/638
6,103,619 *	8/2000	Lai	438/638

OTHER PUBLICATIONS

Nakamura et al., "High Performance Al Dual Damascene Process with Elevated Double Stoppers," Microelectronics Engineering Laboratory, Toshiba Corporation, IEEE (1998).

* cited by examiner

Primary Examiner—Richard Elms

Assistant Examiner—Adam J. Pyonin

(74) *Attorney, Agent, or Firm*—Keith E. Witek; Patricia S. Goddard

(57) **ABSTRACT**

A dual inlaid copper interconnect structure uses a plasma enhanced nitride (PEN) bottom capping layer and a silicon rich silicon oxynitride intermediate etch stop layer. The interfaces (16a, 16b, 20a, and 20b) between these layers (16 and 20) and their adjacent dielectric layers (18 and 22) are positioned in the stack (13) independent of the desired aspect ratio of trench openings of the copper interconnect in order to improve optical properties of the dielectric stack (13). Etch processing is then used to position the layers (16) and (20) at locations within the inlaid structure depth that result in one or more of reduced DC leakage current, improved optical performance, higher frequency of operation, reduced cross talk, increased flexibility of design, or like improvements.

16 Claims, 5 Drawing Sheets

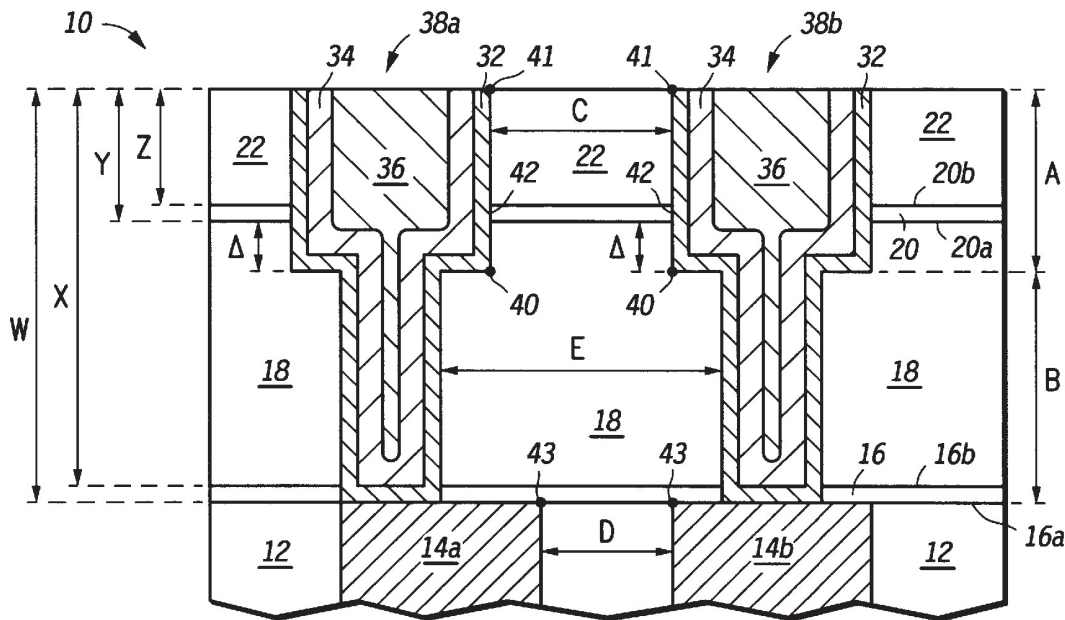

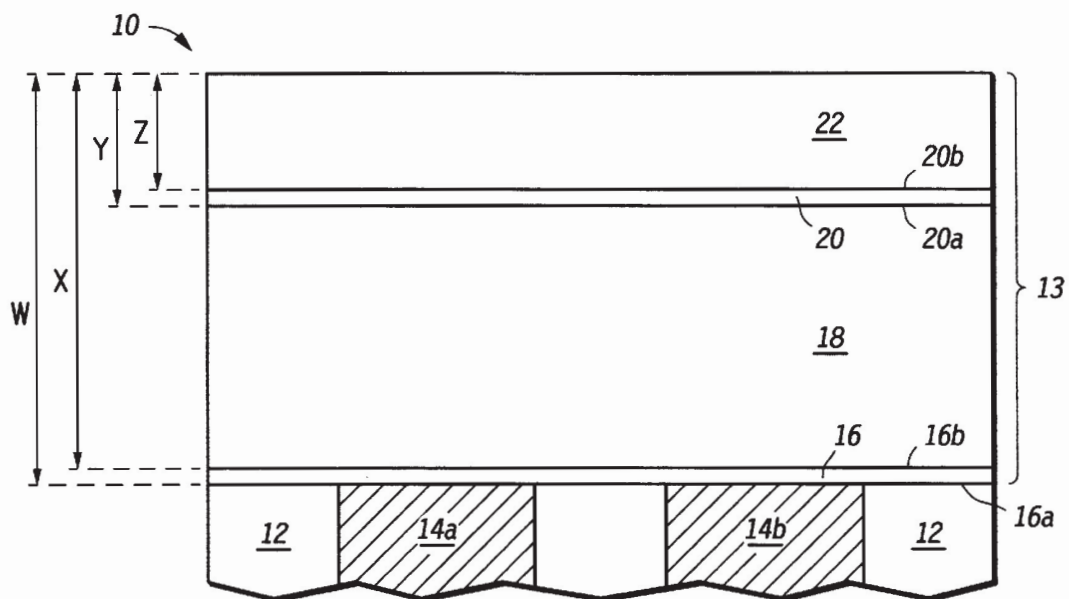

FIG. 1

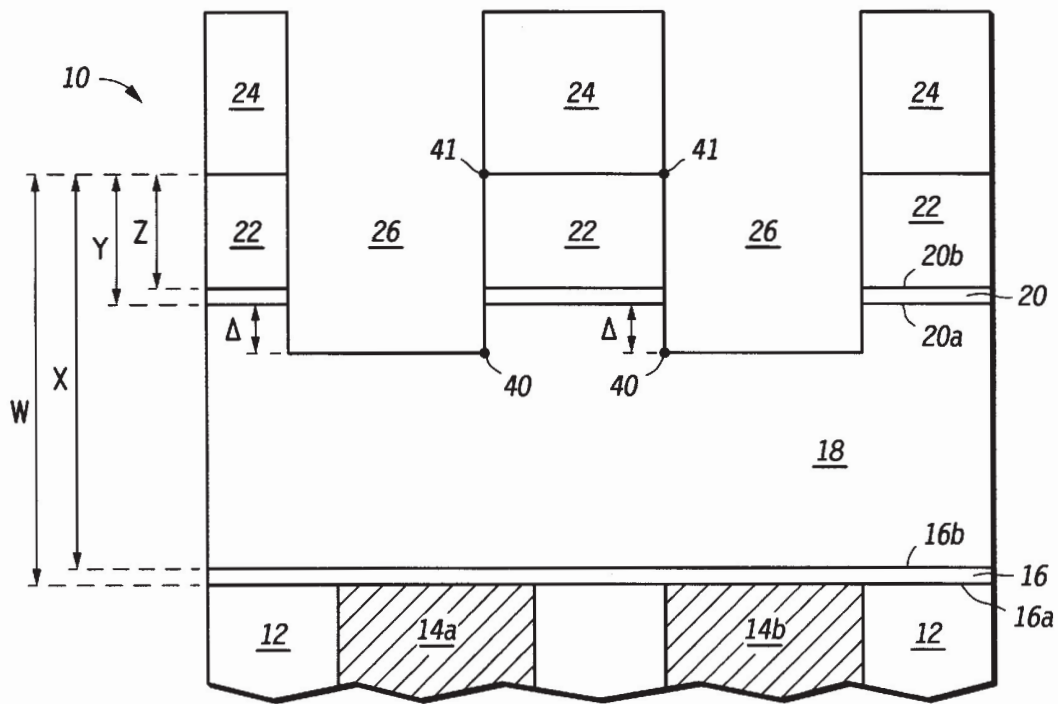

FIG. 2

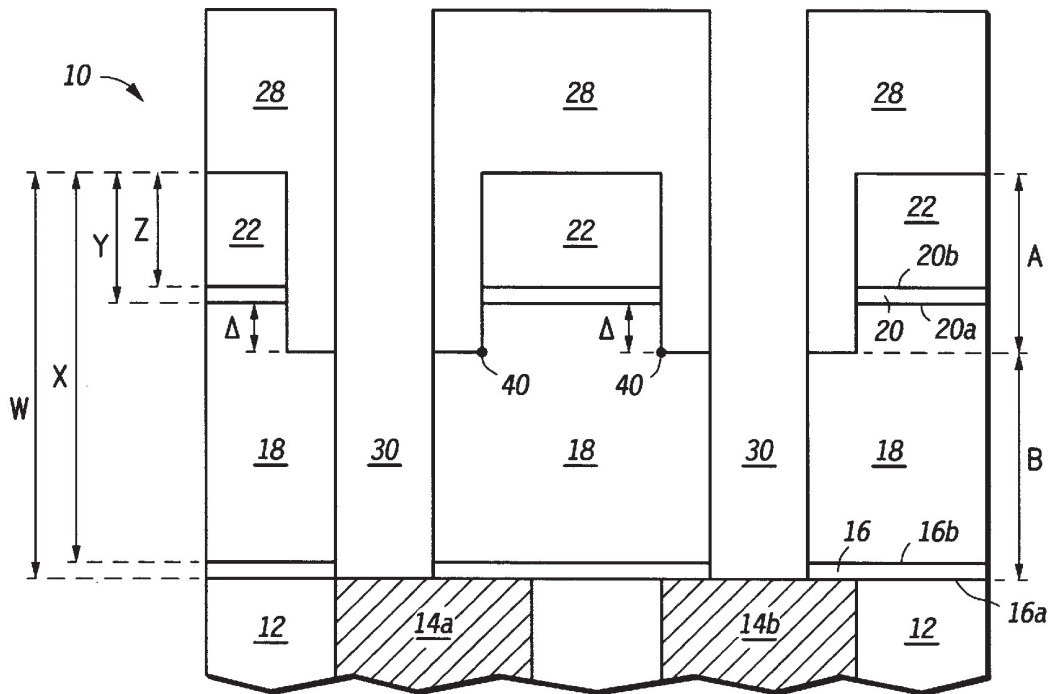

FIG. 3

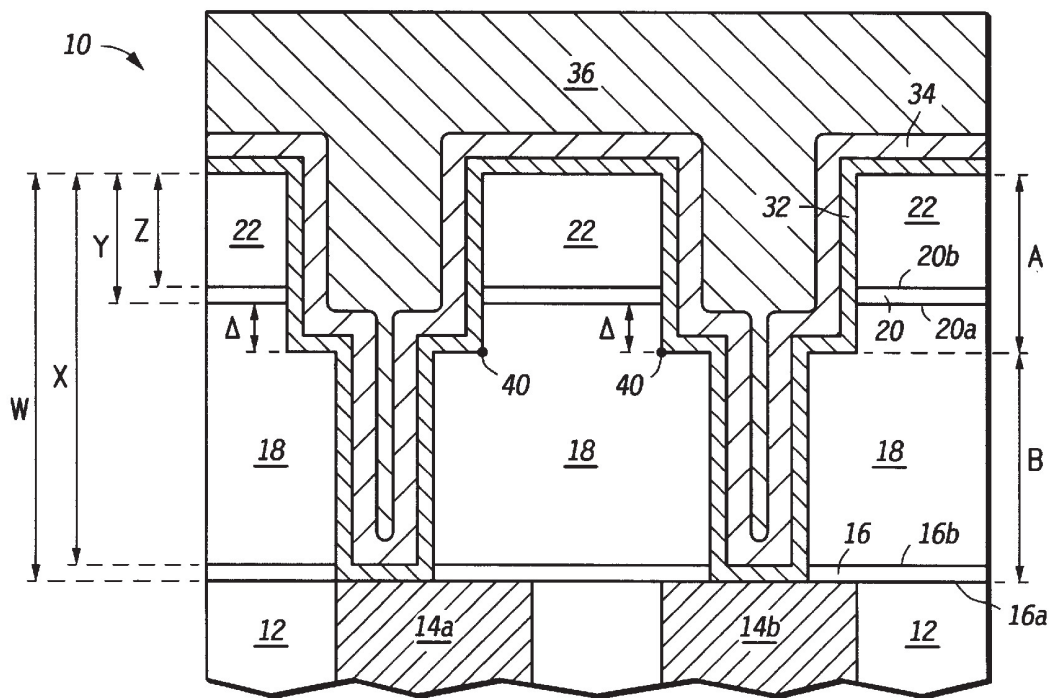

FIG. 4

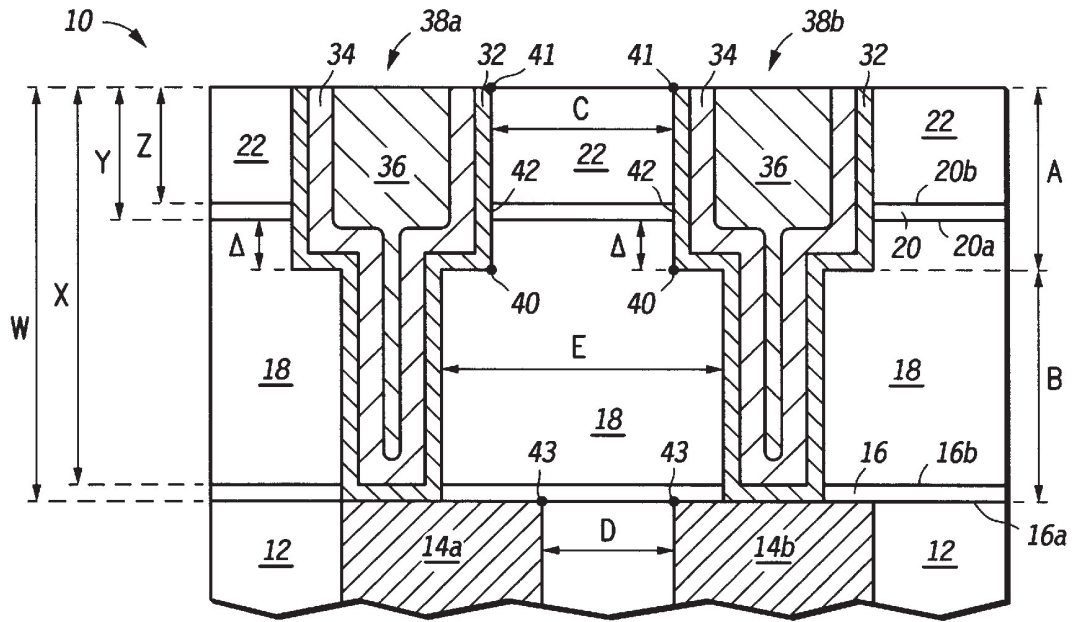

FIG. 5

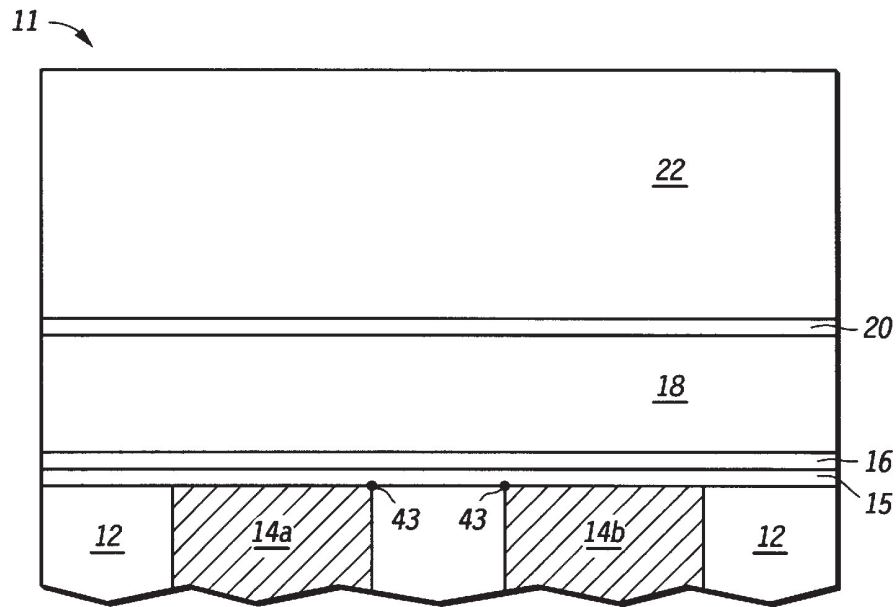

FIG. 6

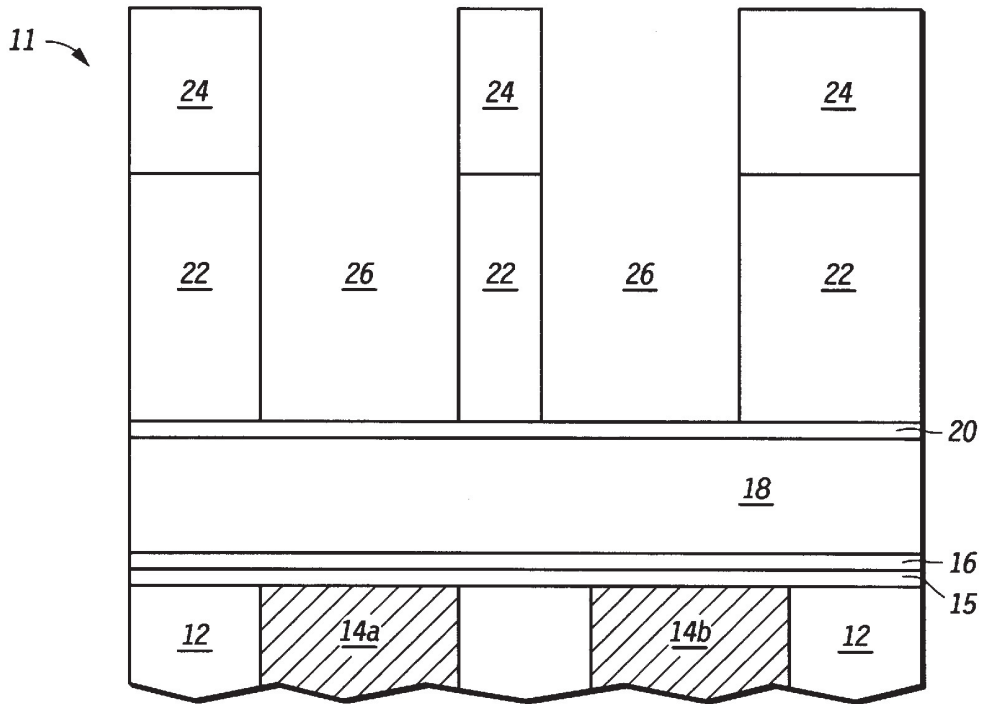

FIG. 7

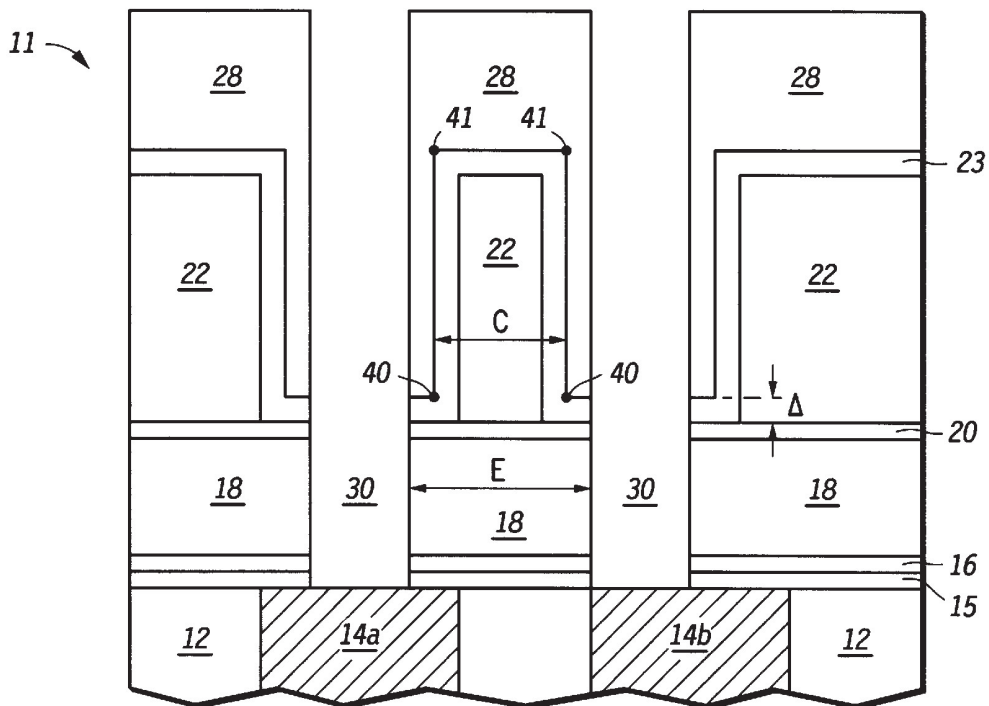

FIG. 8

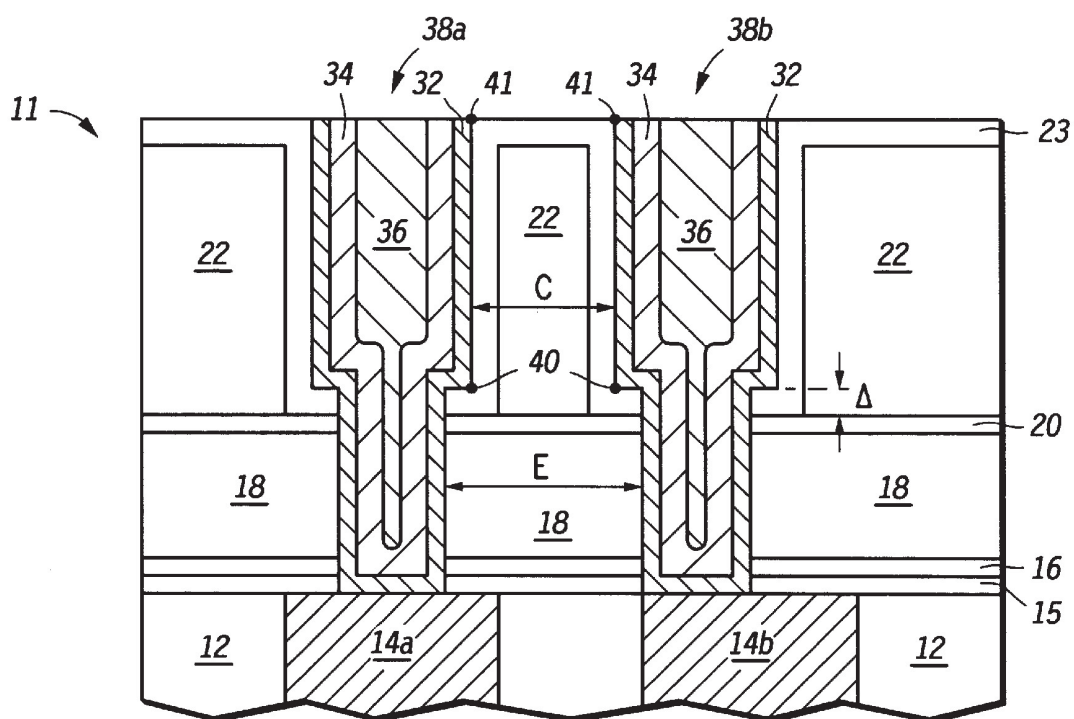

FIG. 9

METHOD FOR FORMING A DUAL INLAID COPPER INTERCONNECT STRUCTURE

FIELD OF THE INVENTION

The present invention relates generally to semiconductor manufacturing, and more particularly to, forming a dual inlaid copper interconnect within an integrated circuit (IC).

BACKGROUND OF THE INVENTION

In the integrated circuit (IC) industry, aluminum interconnects are now being replaced with copper-based inlaid interconnect structures. Copper interconnects are fairly new to the semiconductor industry and are very different from the more commonly used aluminum-based systems. For this reason, copper interconnects have uncovered new problems not before anticipated or addressed by integrated circuit manufacturing facilities. Specifically, a dual inlaid copper interconnect structure comprises at least two etch stop layers interleaved between at least two thicker silicon dioxide layers for a total of four layers of dielectric where aluminum usually required only one dielectric material made via one deposition step. The stack of at least two dielectric layers and at least two etch stop layers used by copper interconnects is lithographically patterned and etched in multiple photo steps and via multiple etch processes where aluminum interconnects generally need no such processing. Further the copper metallurgy itself usually requires multiple materials (e.g., barrier layers, seed layers, bulk layers, etc.), multiple deposition steps, and/or one or more chemical mechanical polishing (CMP) processes where aluminum processes needs only a single and simple deposition step.

In order to make these more complex copper interconnect structures efficiently and with high yield, engineers must consider many different combinations of complexities not before addressed. Specifically, lithographic and etch processing of dual inlaid copper structures must contend with one or more of: (1) adverse chemical interactions related to copper; (2) more complicated optical issues associated with the dielectric interfaces in the copper dielectric stack (e.g., light reflection, destructive interference, light distortion, etc.); (3) disadvantageous electrical properties associated with dielectric materials and etch stop layers within the copper dielectric stack; (4) complications in etch chemistries and etch processing; and (5) the more complicated mechanical integrity of the inlaid structure. While one of these five factors may have been faced by aluminum on occasion, never has a combination of two or more of these issues been a serious concern for aluminum-based ICs.

In addition to the collective weight of several of the five factors enumerated above, many copper-based designs require that different copper layers over the same integrated circuit have different trench depths and thicknesses. For example, the dual inlaid via height within inlaid structures may be designed to vary from layer to layer on the same IC, and different trench interconnect depths within the dual inlaid structures may also vary between the first metal layer and the Nth metal layer within a single integrated circuit (N being up to or greater than eight in current IC devices).

With respect to the first of the five factors enumerated above, integrated circuit engineers are concerned with adverse chemical interactions that are associated with copper based materials and processing. Copper will adversely react with ambient air and oxidize in a manner that could reduce integrated circuit yield and/or adversely increase the resistance of the electrical interconnects. In addition, all etch stops and/or capping layers in contact with the copper must

be adequate diffusion barriers to prevent copper and associated impurities within the copper from diffusing through the film and contaminating adjacent dielectric layers or underlying electrical devices.

In addition to chemical reactions, engineers who are designing copper-based interconnects should also be concerned with the optical properties of the dielectric stack used to define a dual inlaid or inlaid structure. Chemically mechanically polished (CMP) copper has a highly reflective top surface which may readily reflect light/energy during lithographic operations. Furthermore, the plurality of dielectric layers in the dielectric stack of a copper interconnect creates many interfaces of different materials that can adversely reflect light and cause distortion of critical dimensions (CDs) and/or destructive interference whereby photoresist is not properly exposed and developed. In other words, at certain depths of lithographic focus, wavelengths of light, and thicknesses of material, light reflected from a surface of a copper interconnect or dielectric interfaces may destructively interfere or distort various lithographic feature sizes resulting in reduced yield and/or reduced performance of an integrated circuit. Therefore, various etch stop and capping layers within an inlaid copper structure should be geometrically and chemically designed with adequate anti-reflective coating (ARC) properties so that a high yield integrated circuit can be manufactured in an effective manner.

Specifically, the thicknesses of the dielectric and etch stop layers within the dielectric inlaid stack must be carefully engineered to reduce reflectance and/or ensure that any reflectance that occurs is primarily destructive interference when some level of reflection is unavoidable. In addition, the index of refraction (N) and the extinction coefficient (K) of the materials within the dielectric stack need to be carefully considered in order to tune the optical properties of the stack to the wavelength of lithographic light utilized. In addition, the interface between different materials within the dielectric stack must be carefully placed to avoid the various optical problems associated with unwanted reflection.

In addition to the chemical interaction concerns and optical concerns discussed above, various electrical properties of films within the dielectric stack must also be considered. Since the etch stop layers, ARC layers, and/or capping layers of the dielectric stack generally contact the interconnect metallurgy, the etch stop/ARC layers need to be materially engineered and physically placed within the dielectric stack to prevent unacceptable levels of leakage current between adjacent interconnects within an integrated circuit. In addition, the dielectric constants of these materials and/or the physical placement and cross sectional geometry of these materials need to be carefully engineered and considered in order to ensure that the IC may be operated at a high frequency of operation absent of significant cross talk and/or parasitic capacitance. In addition, the above engineering should strive to solve these problems while not to complicating the etch chemistries or the etch steps of the dielectric stack in a manner that is unacceptable.

The various layers contained within a dielectric stack of a dual inlaid copper interconnect create various mechanical concerns as well. The materials used in the dielectric stack must be engineered to provide adequate adhesion between silicon dioxide, copper, and various copper barrier materials. In addition, the stress exerted by these various films on the integrated circuit structure should be at or below an acceptable threshold. Further, the geometric aspect ratio of the via openings and the trench interconnect openings of the dual inlaid structure need to adjusted in order to ensure reduced keyhole formation, reduced voiding, and improved copper electromigration (EM) resistance.

A problem is that any one of the above concerns may be addressed and optimized within an IC interconnect structure when ignoring all the other concerns. When two or three, not to mention all five, of the above discussed concerns are considered at once, it is difficult to make the proper trade-offs and decisions that result in the best possible inlaid structure for a certain set of conditions.

Therefore, it should be evident to one of ordinary skill in the art that many complicated and sometimes conflicting concerns must be considered and balanced when engineering a multi-layer dielectric stack for use in copper interconnected devices. A structure that considers two or more of these needs and creates an improved inlaid structure is needed in the art.

BRIEF DESCRIPTION OF THE DRAWINGS

FIGS. 1–5 illustrate, in cross sectional diagrams, a first method for forming a copper interconnect structure.

FIGS. 6–9 illustrate, in cross sectional diagram, a second method that is used for forming dual inlaid copper interconnects on an integrated circuit (IC).

It will be appreciated that for simplicity and clarity of illustration, elements illustrated in the drawings have not necessarily been drawn to scale. For example, the dimensions of some of the elements are exaggerated relative to other elements for clarity. Further, where considered appropriate, reference numerals have been repeated among the drawings to indicate corresponding or analogous elements.

DESCRIPTION OF A PREFERRED EMBODIMENT

Generally each of the two embodiments taught in FIGS. 1–9 herein teach a copper dual inlaid interconnect process and structure that is formed through a dielectric stack. The dielectric stack is specifically engineered based upon the results of significant experimentation and testing. The materials used for the etch stop/ARC layers and dielectric layers within the dielectric stack, as well as their physical placement within this structure and geometry, were designed to optimize or make acceptable trade-offs between two or more of: (1) optimal chemical protection of copper interconnects; (2) improved optical properties within the dielectric stack; (3) improved electrical properties of the structure; (4) reduced etch processing complexity; and (5) improved mechanical integrity of the copper interconnect. In addition, the interconnect structure processing taught herein are flexible for different environments (different materials, different lithographic wavelengths etc.). Further, the processing taught herein allows integrated circuits (ICs) to be manufactured with multiple layers of metal interconnects wherein each layer of metal may have different trench interconnect opening aspect ratios and different via connection opening aspect ratios.

The materials primarily considered for use as etch stop layers and ARCs herein were chemical vapor deposited (CVD) silicon nitride (SiN_x), plasma enhanced silicon nitride (PEN), silicon oxynitride (SiO_xN_y), and silicon rich silicon oxynitride nitride ($\text{Si—SiO}_x\text{N}_y$). It was found that CVD silicon nitride films resulted in very good line-to-line current leakage performance, but that CVD silicon nitride must be deposited at a temperature that is too high for use with copper. Also, fear of copper cross-contamination generally prevents manufacturing facilities from putting wafers with copper already on them into a CVD furnace. In addition, the higher dielectric constant of most silicon

nitride films (e.g., $\epsilon_r=7.0\text{--}8.0$) when compared to silicon oxide (roughly $\epsilon_r=4.0$) resulted in unacceptable high frequency performance of copper interconnects as well as unacceptable cross-talk in some test structures. Therefore, while CVD silicon nitride may be used as an etch stop or ARC layer within any portion of the dielectric stack taught herein, it was generally determined that a better set of trade-offs could be obtained by avoiding any use of conventional CVD silicon nitride films within the inlaid dielectric stacks taught herein.

In addition to CVD silicon nitride, stoichiometric silicon oxynitride (SiON) was also studied in various positions and geometries within the dielectric stack. Stoichiometric silicon oxynitride with an index of refraction of $n=1.6$ and an extension coefficient of $k=0.0$ showed very low line-to-line leakage as did CVD silicon nitride. However, stoichiometric SiON also acted as a poor anti-reflective coating (ARC) and a poor via etch stop layer within dielectric stacks. Therefore, while stoichiometric silicon oxynitride may be used in the embodiments taught herein, it was generally found that other materials would likely produce a more acceptable dielectric stack for copper dual inlaid use.

In addition to CVD silicon nitride and stoichiometric SiON, silicon-rich SiON films were researched as capping layers and as etch stop layers in a copper dual inlaid dielectric stack. Many compositions of silicon-rich SiON films were found to be excellent anti-reflective coatings (ARCs) and/or excellent etch stop layers within the dielectric stack, however, their use as a copper capping layer was not practical. SiON was less attractive as a copper capping layer since this material had a greater likelihood of chemically reacting with the copper at the Cu—SiON interface. This reaction produced interfacial films which were shown to occasionally increase leakage current between adjacent copper interconnects and increase sheet resistance within individual interconnects. Therefore, when considering several of the five areas of concern enumerated above when searching for an improved etch stop, capping, and ARC layer combination, it was found that a silicon-rich silicon oxynitride films were best put to use as an intermediate etch stop layer near a central portion of the inlaid dielectric stack. However, Si-rich SiON material can be engineered to be generally used in any etch stop, ARC layer, or capping function within the devices taught herein, sometimes to less, but potentially acceptable, effect.

The final of the four layers researched for use in the dielectric stack was plasma enhanced silicon nitride (PEN). It was found that plasma enhanced silicon nitride was an optimal capping layer to place in direct contact with copper since experimental results indicated either no degradation in sheet resistance or an acceptable interconnect resistance. In addition, PEN resulted in a reduction in leakage current while the containment and protection of the copper over time was within accepted tolerances.

In addition to determining the optimal material composition of various etch stop layers, ARC layers, and capping layers within the dielectric stack, the embodiments taught herein specifically engineer the various thicknesses, geometric properties, and physical positions of layers within the inlaid dielectric stack in order to improve or maintain the optical integrity of the interconnect structure during manufacturing. Therefore, the selection of materials discussed above has typically improved the chemical stability of the copper interconnect, improved the electrical properties of the interconnect structures, and provided adequate mechanical stability to the integrated circuit while at the same time being engineered to provide adequate or improved optical

properties over and above that available in prior art inlaid structures. In addition to obtaining these benefits, the etch processing taught herein is not significantly complicated compared to conventional copper processing. In addition, the resulting cross-sectional geometries (i.e., aspect ratio) of the trench interconnect opening in the via interconnect opening are also optimized in the structures herein to allow for formation of copper interconnects with reduced voiding and keyholes so that integrated circuit (IC) yield is enhanced.

Specific details of the various embodiments may be understood with specific references FIGS. 1–9.

Specifically, FIGS. 1–5 illustrate a first embodiment that may be used to form a dual inlaid copper interconnect structure within an integrated circuit (IC).

FIG. 1 illustrates a few beginning process steps that are used to start the formation of an integrated circuit 10. Integrated circuit 10 is to contain one or more layers of inlaid copper interconnect structures. In FIG. 1, all the shown elements are formed over a substrate surface, printed circuit board (PCB) or like substrate. While not specifically illustrated in FIG. 1, the substrate material which is commonly used for integrated circuit formation is one of silicon, silicon germanium, germanium, gallium arsenide, other III-V compounds, a silicon carbide, epitaxial regions, silicon on insulator (SOI) substrates, or like starting material. Over this substrate is formed any number of passive devices such as resistors, capacitors, inductors, diodes, and the like. In addition, the substrate may support up to millions of integrated active devices, such as NMOS transistors, PMOS transistors, bipolar transistors, JFETs, thyristors, SCRs, memory cells, logic gates, and/or like electrical circuitry. Furthermore, micromachined and/or electromechanical devices such as pressure transducers, gears, engines, detectors, and/or the like may be formed on the integrated circuit (IC) substrate.

The various devices that are formed on top of the substrate may be interconnected by one or more metallic layers. A single metallic layer may be used to form many segmented interconnects across the integrated circuit (IC). FIG. 1 specifically illustrates that a first metallic layer is used to form at least two such interconnects 14a and 14b. FIG. 1 illustrates that a dielectric layer 12 is generally used to electrically isolate one interconnect 14a from another interconnect 14b within one metallic layer. Any one interconnect layer of an integrated circuit may contain millions of individuals and segmented interconnects similar to 14a and 14b, and an integrated circuit may contain up to 8 or more stacked layers of interconnect metallurgy over the top of one another. In FIG. 1, interconnects such as 14a and 14b are generally formed as one of either tungsten (W) plugs, tungsten local interconnects, aluminum wiring, inlaid copper interconnects, polysilicon regions, dual inlaid copper interconnects, composite metallic contacts, and/or like integrated circuit conductive members. In addition, various dielectric layers taught herein, such as dielectric layer 12, are usually one or more of tetraethylorthosilicate (TEOS), fluorine doped TEOS (f-TEOS), low k dielectrics, borophosphosilicate glass (BPSG), phosphosilicate glass (PSG), spin on glasses (SOG), silicon nitride layers, metal oxides, air gaps, composites thereof, and/or like dielectric regions.

FIG. 1 illustrates that a dielectric stack 13 is formed over a top of the interconnects 14a and 14b and a top of the dielectric layer 12. Generally, a dielectric stack is any vertically stacked combination of two or more different dielectric materials. Specifically, FIG. 1 illustrates a dielec-

tric stack 13 that contains four layers 16, 18, 20, and 22. The layers 16, 18, 20, and 22 are subsequently used to form dual inlaid copper interconnect structures across an IC.

As previously discussed, the capping layer 16 must be physically positioned, geometrically designed, and composed of a material that provides certain acceptable properties and/or functions. Generally, the layer 16 should be an acceptable protective layer for the interconnects 14a and 14b, especially if these layers may be adversely affected by exposure to an environment. For example, if layers 14a and 14b are a copper-based interconnects, layer 16 should provide adequate containment and protection of copper to prevent or reduce copper oxidation or contamination. Furthermore, layer 16 should function as an adequate barrier layer that prevents any copper contaminants or like contaminants from diffusing from regions 14a and 14b into adjacent dielectric layers such as layers 12 and 18. The thickness and position of the layer 16 as well as its index of refraction (N) and its extinction coefficient (K) should serve to improve the optical integrity of the dielectric stack 13 (i.e., reduce distortion, reduce destructive interference, etc.). Proper engineering of this layer will result in reduced destructive interference upon light reflection, diminish any intensity of reflected light, and reduced distortion of lithographic critical dimensions (CD's) upon reflection. In addition, layer 16 should be chosen to provide acceptable levels of leakage current between the layers 14a and 14b while providing for high frequency performance having reduced cross talk between layers 14a and 14b.

As previously discussed, it has been determined that a plasma enhanced silicon nitride (PEN) layer is an optimal layer for use as layer 16 in FIG. 1 in order to reasonably obtain the above objectives. While it was found that plasma enhanced nitride (PEN) is a most appropriate choice for the material used for layer 16, other materials such as silicon oxynitride, silicon rich silicon nitride, silicon rich silicon oxynitride, CVD silicon nitride, or composites of these materials with or without PEN may be used as the capping layer 16 in FIG. 1. It was found that a thickness of the layer 16 of roughly 500 angstroms worked well when using lithographic exposures of roughly 365 nm (i.e., I-line). However, other thicknesses may be used for I line, and other thicknesses are used for different wavelengths of exposure in order to optimally change the dimensions X and W in the figures do different lithographic characteristics. Other thicknesses may be easily derived for other commonly used lithographic wavelengths, such as 248 nm (deep UV). In essence, the thickness of this film as well as its placement within the stack is also largely a function of the wavelength used for lithographic operations as is the engineered index of refraction and extension coefficient of this film. In addition, the reflective properties of the interface 16b and 16a is also largely a function of the composition and physical dimensions of the layers 18 and 12. Therefore, while an optimal layer 16 is roughly a 500 angstrom PEN layer when using I-line in the environment discussed herein, other reasonable thicknesses and other materials may be used for layer 16 under different circumstances.

A dielectric layer 18 is formed within the dielectric stack 13 overlying the capping layer 16. In a preferred form, for improved electrical properties, adequate mechanical properties, and adequate optical properties, the layer 18 was selected as a CVD TEOS layer. However, the layer 18 may be any other dielectric layer taught herein or may be any composite thereof. Generally, the thickness of the layer (X-Y) is selected to be roughly 8000 angstroms in thickness. This thickness is selected to improve the optical properties

of the structure when using lithographic wavelengths of 365 nanometers (I-line) for photoresist processing over the dielectric stack **13**. It should be understood that different thicknesses will result when different lithographic wavelengths are used, different material compositions are selected, different thicknesses of material are deposited, different interfaces are created, different chemical compositions are formed, and/or the like.

After formation of the layer **18**, an etch stop layer **20** is deposited over the layer **18** and the dielectric stack **13**. Generally, the layer **20** is chosen as any layer that can be an etch stop for the overlying layer **22**. In addition, it is advantageous if the layer **20** prevents copper leakage. Further, the thickness and material composition of layer **20** should be engineered to improve the optical properties of the overall structure **13**. Since the layer **20** will generally be adjacent or in close proximity to the trench interconnect regions and since these trench interconnect regions are more closely spaced to each other via dimension C (see FIG. 5), the layer **20** of FIG. 1 needs to be electrically robust enough to ensure low levels of leakage current. Further, an improved device is formed if the layer **20** has a dielectric constant and capacitive geometry that is conducive to higher frequencies of operation without adversely high parasitic capacitors and/or excessive cross talk.

A material that was found to provide a good trade off and balance among the above considerations was silicon-rich silicon oxynitride (Si—SiON). A silicon rich silicon oxynitride film provides an excellent antireflective coating (ARC) for improved optical properties and was also found to be an excellent etch stop layer for the overlying layer **22**. In addition, the minimal surface area contacted the layer **20** to any subsequent metallurgy ensured that any reactions that could occur therebetween were of little impact to the overall performance of the device. It was found that the SiON layer

20 and the barrier materials of the copper interconnect, if they reacted with each other, did not result in unacceptable degradation in sheet resistance or unacceptable increase in line-to-line leakage current.

Generally, a thickness of the silicon-rich SiON layer **20** (Y-Z) is on the order of 600 angstroms for I-line lithographic processing. It is important to note that different thicknesses of layer **20** may be used and that different materials or composites of materials other than silicon-rich silicon oxynitride may be used for layer **20**. For example, a thicker layer of stoichiometric silicon oxynitride may replace the silicon rich silicon oxynitride layer **20**, but such a layer would likely need to be at least 1000 angstroms in thickness whereby etch throughput, leakage, etc. may be altered. Other composite materials and/or different thicknesses may be optimal in other circumstances where different materials are used for layers **18** and **22**, different lithographic wavelengths are used, or different conditions apply. However, for the materials discussed so far and for I-line lithography of 365 nanometers, the 600 Angstroms silicon rich SiON layer is optimal with the above discussed layers **18** and **20**.

After formation of layer **20**, a top layer **22** is formed as a top portion of the dielectric stack **13**. Layer **22** is generally analogous to the layer **18** in term of material composition. However, the layer **22** is generally deposited to a thickness that is less than the layer **18**. As shown in FIG. 1, various surfaces **16a**, **16b**, **20a** and **20b** must be adequately positioned within the trench and subject to properly engineered indices of refraction in extinction coefficient values in order to improve the optical characteristics of the overall interconnect structure. For this purpose, the layer **22** is generally a CVD TEOS layer that is roughly 4000–5000 angstroms in thickness.

In summary of FIG. 1, an acceptable dielectric stack was found to be:

TABLE 1

Wavelength of Lithography	Layer ID and Material	Thickness of Layer (range and target)	Useful Process Information	Refractive Index (N)	Extinction Coefficient (K)
I-line 365 nm	bottom etch stop 16 (PEN layer)	300–800 Angstroms, 500 Angstrom target	use a parallel plate RF reactor by Applied Materials, flow both SiH ₄ and NH ₄ at 370° C. to 410° C.	1.5–3.0 with roughly 2.3 being a target	0.0 to 0.4 with 0.027 being a target
	bottom dielectric layer 18 (TEOS layer)	6,000–10,000 Angstroms, 8,000 Angstrom target			
	top etch stop layer 20 (Si rich SiON)	300–800 Angstroms, 600 Angstrom target	use a parallel plate RF reactor by Applied Materials, flow all of SiH ₄ , N ₂ O, and NH ₄ , at 370° C. to 410° C.	2.0–4.0 with one of either 2.8 or 3.5 being a target	0.1 to 1.0 with one of either 0.3 or 0.7 being a target
Deep UV 248 nm	top dielectric layer (TEOS layer)	3,000–6,000 Angstroms, 4,500 Angstrom target			
	bottom etch stop 16 (PEN layer)	300–800 Angstroms, 500 Angstrom target	use a parallel plate RF reactor by Applied Materials, flow both SiH ₄ and NH ₄ at 370° C. to 410° C.	1.0–3.0 with roughly 2.1 being a target	0.0 to 0.4 with 0.0 being a target
	bottom dielectric layer 18 (TEOS layer)	6,000–10,000 Angstroms, 8,000 Angstrom target			
	top etch stop	300–800	use a parallel plate	2.0–4.0 with 2.5	0.1 to 1.5 with 0.9

TABLE 1-continued

Wavelength of Lithography	Layer ID and Material	Thickness of Layer (range and target)	Useful Process Information	Refractive Index (N)	Extinction Coefficient (K)
	layer 20 (Si rich SiON)	Angstroms, 600 Angstrom target	RF reactor by Applied Matenals, flow all of SiH ₄ , N ₂ O, and NH ₄ , at 370° C. to 410° C.	being a target	being a target
	top dielectnc layer (TEOS layer)	3,000–6,000 Angstroms, 4,500 Angstrom target			

In addition, stoichiometric SiON may be used in place of the silicon-rich SiON if formed to thicknesses above 1000 Angstroms with an N value of roughly 1.6 and a K value of roughly 0.0 at I-line (365 nm) lithographic exposure. Stoichiometric SiON when exposed with Deep UV was similar except that N was roughly 1.7 and K was roughly 0.03.

FIG. 2 illustrates that a photoresist layer 24 is spin coated or deposited over a top of the layer 22. A lithography mask is then placed between a light source or energy source and the photoresist 24. Energy or light is then passed selectively through the mask or altered by the mask to selectively expose portions of the photoresist 24. Generally, this exposure is I-line exposure at 365 nanometers. However, other lithographic processes such as deep UV at 248 nanometers, phase shift lithography, x-ray, SCALPEL, or other lithographic wavelengths or processing may be used.

As previously stated, changes in the lithography process may require changes in the thicknesses, materials, placement, or processing of the dielectric stack 13 to further optimize the stack 13 to these environmental alterations. It is important to note that the lithographic wavelength of light that used will generally determine the dimensions W, X, Y, and Z illustrated in FIG. 1. When using I-line lithography at 365 nanometers, a roughly 4000–5000 angstrom thickness of TEOS layer 22, a roughly 600 angstrom thickness of silicon rich SiON layer 20, a roughly 8000 angstrom thickness of TEOS layer 18, and a roughly 500 angstrom thickness of the plasma enhanced nitride (PEN) layer 16 creates interfaces 16A, 16B, 20A, and 20B at depths W, X, Y, and Z that prevent or substantially reduce adverse destructive interference and/or distortion when performing the lithographic step illustrated in FIG. 2 (see Table 1 above).

After the portions of the photoresist 24 are lithographically exposed as taught herein, a chemical development process is used to remove certain portions of the photoresist 24 selective to other portions of the photoresist. After photoresist development, the wafer is placed within a reactive ion etch (RIE) chamber or like plasma etch system whereby an oxide etch is used to remove portions of the layer 22 that are exposed by the openings in the photoresist layer 24. This oxide etch is generally performed selective to the silicon rich silicon oxynitride (Si—SiON) layer 20. Optical endpoint detection or like endpoint techniques may be used to determine when a substantial portion of the layer 20 has been exposed through the dielectric layer 22. At this point, the etch chemistry is altered to a second etch chemistry which removes exposed portions of the SiON layer 20 within the openings in the photoresist 24.

It is important to note that the layer 20 is positioned at a relatively shallow height Y within the dielectric stack 13 to result in improved optical properties within the dielectric stack 13 during lithographic operations. However, adequate

trench interconnect cross-sectional area is needed to produce acceptably low line resistance and to create desired aspect ratios for subsequent CVD, electroplating, electroless, or like copper fill operations. Proper aspect ratios are preferred since certain aspect ratios are better than others at reduce voiding and key hole formation during copper fill operations. In order to provide for this optimal geometry or aspect ratio of the trench region 26, the trench region 26 is extended by an additional oxide etch a distance Δ into the layer 18 as illustrated in FIG. 2. Generally, Δ is a few hundred Angstroms to a few thousand Angstroms with about 1,000 Angstroms being typical. Generally, etch stop layers are used to ensure uniformity and repeatability within a dielectric stack etching process. Therefore, trenching beyond the depth of an etch stop layer via an additional timed etch is unusual in the art. However, due to current advances in conventional timed etch processing, the standard deviation from wafer-to-wafer and the standard deviation across a surface of a single wafer when performing the Δ etch of layer 18 in FIG. 2 is very acceptable. This over-etch is so well controlled using modern oxide etch procedures that the dimension Δ can be controlled to within a distribution of few tens or hundreds of angstroms for all openings 26 wafer-to-wafer and across the same wafer. Therefore, even though an additional trenching operation into layer 18 is performed, repeatable and consistent dimensions of a trench interconnect opening 26 are very possible since the dimension Δ is only a fraction of the total depth of the trench interconnect region 26. After formation of the trench interconnect openings 26, the photoresist 24 is removed by an ashing process.

The positioning of the SiON layer 20 at a shallow depth the stack 13 and compensating for such shallow placement by a Δ etch is advantageous for two reasons. First, this shallow positioning of the layer 20 improves the optical properties of the dielectric stack 13. An additional benefit from this shallow placement of the layer 20 along with the Δ etch is that the SiON layer 20 is physically placed along a side wall of the trench region 26 so that layer 20 is physically removed vertically from the trench interconnect corners 40 and 41 as illustrated in FIG. 2. When placing a high dielectric constant material (e.g., silicon nitride with $\epsilon_r \sim 8$) at these corners 40 and/or 41, the electrical performance of copper inlaid interconnects is degraded by greater direct current (DC) leakage and reduced high frequency performance. Therefore, the shallow positioning of layer 20 in the dielectric stack 13 for the purpose of optical improvements may have the side effect of also improving the electrical properties of the interconnect structure.

FIG. 3 illustrates that a second photoresist layer 28 is deposited over a surface of the wafer after the openings 26 are formed via FIG. 2. A second masking, lithographic, and chemical development process is used in FIG. 3 to form via

openings within the photoresist **28** as illustrated in FIG. **3**. These via openings in the photoresist **28** expose a via portion of the layer **18** within the trench interconnect **26**. These via portions are etched by an oxide reactive ion etch (RIE) or a like plasma process until portions of the plasma enhanced nitride (PEN) layer **16** is exposed. At this point, via a timed etch or some form of etch endpointing, the etch chemistry and/or process parameters are switched to a plasma enhanced nitride etch which removes exposed portions of the layer **16** within the vias **30**. In another embodiment, a timed etch may be performed whereby no stopping on the nitride layer occurs. The resulting via openings **30** expose some portion of the regions **14a** and **14b** to enable electrical contact of the regions **14a** and **14b** to overlying metallurgy that is formed in later processing steps.

Due to the additional Δ trenching performed during the interconnect trench **20** etch illustrated in FIG. **2**, the depth of via opening **30** (shown as dimension B in FIGS. **3-5**) is less than what the via depth would have been had the via opening started at the bottom of the etch stop layer **20**. Therefore, the aspect ratio of the via opening **30** may also be adjusted by adjusting the Δ trenching. Proper Δ trenching has been found to provide an aspect ratio of the via **30** that is more easily and completely filled with copper interconnect material without unwanted voiding and/or keyhole formation. This has also been shown to improve the electromigration (EM) resistance of the various copper interconnects formed herein. Generally, for I-line lithographic processing of 365 nanometers, a trench interconnect depth A equal to 6000 angstroms and a via depth B of approximately 7000 angstroms is typical (see dimensions A and B in FIGS. **3-5**).

FIG. **4** illustrates that the photoresist **28** is ashed off of or removed from the surface of the device **10** after formation of the via portions **30**. FIG. **4** then illustrates that some deposition and/or sputtering process is used to form a barrier layer **32** within the interconnect structures illustrated in FIG. **3**. Typical copper barrier materials include tantalum, titanium nitride, tantalum nitride, titanium tungsten, tungsten nitride, tungsten, composites thereof, or like barrier materials. Typical thicknesses of barrier layers range from 200 Angstroms to 1,000 Angstroms with 600 Angstroms being typical.

After formation of the barrier layer **32**, FIG. **4** illustrates that a CVD copper seed layer **34** is deposited over the barrier **32**. The seed layer **34** is then used to electroplate or electroless plate a bulk copper layer **36** over a top of the layer **34**. In another form, a single CVD process or a multi-step CVD methodology may be used to form the bulk layer **36** and the layer **34** without electroless plating or electroplating. The copper layer may also include various conductive capping layers that are similar to the layer **32**, and the copper-based interconnect layers **32** and **24** may be a pure copper layer or a copper alloy comprising 10% or more of copper by volume.

FIG. **5** illustrates that a chemical mechanical polishing (CMP) process is used to polish top portions of the layers **32**, **34**, and **36** from a surface of the structure **10**. Completion of the polishing operation will result in the formation of a first dual inlaid interconnect **38a** and a second dual inlaid interconnect **38b** via a single layer of metallurgy as shown in FIG. **5**. Generally, a single layer of metallurgy will form thousands or even millions of interconnects similar to that shown in FIG. **5**.

The structure illustrated in FIG. **5** has been optimized over the prior art in one of several ways. By choosing a plasma enhanced silicon nitride (PEN) layer as the layer **16** an

improved capping layer of layers **14a** and **14b** has been created. Decent capping layers are needed especially if the underlying metal regions **14a** and **14b** are copper-based interconnects. Such capping layers will prevent diffusion of copper and other associated copper impurities into adjacent oxides and underlying electrical devices.

In addition, by choosing silicon rich silicon oxynitride (Si—SiON) as the layer **20** of FIG. **5**, an improved intermediate etch stop layer has been formed over that found in the prior art. It was found that the SiON layer is easily formed with a dielectric constant of $\epsilon_r \leq 7.0$ with $\epsilon_r = 6.5$ being likely. This has been shown to reduce line-to-line leakage as well as improve high frequency operation of the IC **10**. By choosing these materials for layers **16** and **20**, as well as some form of TEOS for layers **18** and **22**, and by choosing appropriate depths W, X, Y, and Z independent of the desired aspect ratio of the trench region **26** and the via portion **30**, the optical properties of the dielectric stack **13** are optimized or at least improved for any desired lithography. Furthermore, the positioning of the layer **20** away from trench interconnect opening corners **40** and **41** has improved high frequency performance where regions **38a** and **38b** may either be moved closer together to reduce die size or driven to higher operation frequencies (e.g., the GigaHertz range). In addition, the use of the additional oxide etch that results in the offset Δ is used to correct the aspect ratio of the trenches **26** and **30** in FIGS. **2** and **3** respectfully so that metallurgical fill of these dual inlaid regions is improved. Furthermore, by simply changing the Δ etch from wafer-to-wafer or from layer-to-layer on the same wafer, many different via depths and trench depths may be accommodated within an integrated circuit while optical performance is not degraded. This flexibility is also an advantage since different metallic interconnect layers on the same device **10** may have different aspect ratios as is required by different designs (e.g., different design rules, process flows, device functionality, lithographic processing, etc., may require changes in the aspect ratios).

FIGS. **6-9** illustrate an alternate embodiment that may further improve upon the DC leakage current and high frequency operation of the embodiment discussed with respect with FIGS. **1-5**. Such improvement can be better understood with reference to the dimensions C and D in FIG. **5**. From FIG. **5**, it is clear that the dimension D between regions **14a** and **14b** is small. In some cases, dimension D may be on the order of less than 1-2 microns. In addition, the presence of the layer **16** at the top corners **43** of the regions **14a** and **14b** ensures that leakage between regions **14a** and **14b** through the layer **16** is probably non-optimal. In addition, the cross-sectional area of vias is considerably smaller than that of trenches. Therefore, if a process can be developed that results in the layer **20** being positioned on the sidewalls between the via openings along the dimension E as opposed to between sidewalls of trench interconnect regions **26** along the dimension C, leakage current and high frequency performance of an integrated circuit **10** may be enhanced. Further, such leakage current performance and high frequency operation may be further improved by additionally removing a high leakage layer **16** from contact with the points **43** of FIG. **5** and placing a lower leakage layer **15** in contact with the points **43**. However, the layer **15** still needs to be a decent barrier for copper to prevent copper diffusion if the regions **14a** and **14b** are copper-based interconnects.

FIGS. **6-9** illustrate a process which obtains these results at the expense of the tradeoff of complicating the via opening etch process.

FIG. 6 illustrates a structure **11** very similar to the structure **10** illustrated in FIG. 1. Elements in regions in FIG. 6 that are analogous to elements in regions in FIG. 1 are identified by identical alphanumeric labels. These redundant layers are not discussed with respect to FIG. 6 due to the fact that they are extremely similar or identical to their analogous layers set forth with respect to FIG. 1. One difference between FIG. 6 and FIG. 1 is the presence of an optional pad dielectric layer **15**. Generally, the layer **15** is any material that is a barrier to copper and provides reduced DC leakage and improved high frequency operation. For example, layer **15** may be a very thin stoichiometric SiON layer that is formed as discussed herein. In other forms, one of the layers **16** or **15** may be a nitride layer, a oxynitride layer, an undoped silicon layer, an organic dielectric, a silicon rich nitride or oxynitride, etc., while the other layer is a different material selected from that same group. The purpose of the layer **15** is to offset a more current leaky layer **16** from the corners **43** of the regions **14a** and **14b**. In other forms, the etch stop layer **16** may be placed in direct contact with the regions **14a** and **14b** as in FIG. 1 whereby the layer **15** is not used. With layer **15**, the leakage current and high frequency operation between the regions **14a** and **14b** may be improved.

FIG. 7 illustrates that a photoresist layer **24** or like photosensitive layer is used to etch an opening in the layer **22**. Instead of trenching through the region **22** as shown in FIG. 2 and instead of trenching by a dimension Δ into the layer **18**, such etch operations are not performed in FIG. 7. Instead, once a timed etch or optical or chemical endpoint process results in exposure of the layer **20**, the photoresist layer **24** is ashed from a surface of the device **11**.

FIG. 8 illustrates that a dielectric layer **23** is deposited over a contour of the etched layer **22** illustrated in FIG. 7. Generally, the layer **23** is deposited as a fluorine doped TEOS layer, a CVD TEOS layer, an ozone TEOS layer, a low k dielectric, composites thereof, or any other dielectric layer discussed herein. Further, layer **23** may contain some barrier material that is useful for containing copper during subsequent processing. It is important to note that FIG. 8 illustrates that the layer **23** is a conformal layer that is not exposed to an etch process before photoresist material **28** is formed. However, it should be noted, that the material **23** may be reactive ion etched (RIE processed) or plasma etched to form dielectric sidewall spacers along vertical walls of layer **22** before formation or after stripping of the photoresist layer **28**. In either event, the step of depositing the layer **23** provides a thickness Δ of material between the leaky and higher dielectric constant material **20** and the bottom surface/corners **40** of the interconnect trench region **26**. Therefore, similar to the embodiment illustrated in FIG. 5, the layer **20** has been removed from the corners **40** and **41** of the dual inlaid structure whereby leakage current and high frequency operation is improved.

In FIG. 8, the photoresist layer **28** is formed. A sequential etch operation involving an oxide etch, followed by a SiON etch, followed by an oxide etch, followed by a PEN etch is used to expose top surfaces of the layers **14a** and **14b** to a via opening **30**.

FIG. 9 illustrates that conventional barrier and copper processing along with chemical mechanical polishing (CMP) is then used to form the metallic layers **32** through **36** in a manner similar to that discussed with respect to FIG. 5. FIG. 9 differs from the structure illustrated in FIG. 5 by virtue of the fact that both etch stop, capping, and/or ARC layers **20** and **16** physically reside between interconnects **38a** and **38b** in FIG. 9 only along the greater dimension E

between via openings and not between the regions **38a** and **38b** along the shorter dimension C. By virtue of contacting the layer **20** along the dimension E in FIG. 9 as opposed to the dimension C in FIG. 5, leakage currents may be reduced and high frequency operation may be enhanced. This improvement is obtained while the layer **23** may be used to simultaneously provide additional isolation between interconnect trench regions and while aspect regions of the trench interconnect openings and via openings are still maintained within prudent ranges. One drawback of the process of FIG. 6 through FIG. 9 is that the four-step via etch procedure discussed with respect to FIG. 8 is more complicated than the via etch processing discussed in FIG. 3. However, in some embodiments, the complexity of the etch of FIG. 8 is worth the tradeoff of the possibility of improved high frequency operation and reduced DC leakage current. Therefore, either the process of FIGS. 1-5, the process of FIGS. 6-9, or some combination/hybrid of these two processes may be used to form one or more inlaid or dual inlaid copper interconnect structures for an integrated circuit **10** or **11**.

Although the invention has been described and illustrated with reference to specific embodiments, it is not intended that the invention be limited to those illustrative embodiments. Those skilled in the art will recognize that modifications and variations may be made without departing from the spirit and scope of the invention. For example, the embodiments taught herein teach a trench-first via-last dual inlaid formation process. It is possible to perform a via-first trench-last dual inlaid structure in the embodiments taught herein and the teachings herein should be so construed. Therefore, it is intended that this invention encompass all of the variations and modifications as fall within the scope of the appended claims.

What is claimed is:

1. A method for forming an interconnect, the method comprising the steps of:

- forming a first etch stop layer from a first material;
- forming a first dielectric layer over the first etch stop layer;
- forming a second etch stop layer from a second material that is different from the first material;
- forming a second dielectric layer over the second etch stop layer;
- etching an interconnect trench entirely through a portion of the second dielectric layer and the second etch stop layer where the interconnect trench is etched into a portion of the first dielectric layer;
- etching a via portion through a bottom portion of the first dielectric layer and the first etch stop layer;
- filling both the interconnect trench and the via portion with a metal interconnect;

wherein etching the interconnect trench, including etching the portion of the first dielectric layer, is performed prior to etching the via portion.

2. The method of claim 1 wherein the first etch stop layer is formed over a top of and in contact with an underlying metallic region.

3. The method of claim 2 wherein the underlying metallic region is a copper-based dual inlaid interconnect.

4. The method of claim 1 wherein the first etch stop layer is a plasma enhanced silicon nitride (PEN) layer.

5. The method of claim 1 wherein the second etch stop layer is a silicon rich silicon oxynitride layer.

6. The method of claim 5 wherein the first etch stop layer is a plasma enhanced silicon nitride (PEN) layer.

15

7. The method of claim 1 wherein the metal interconnect is a barrier layer underlying a copper-based interconnect.

8. The method of claim 1 wherein the first dielectric layer is thicker than the second dielectric layer.

9. The method of claim 1 wherein the first dielectric layer is at least 3000 Angstroms thicker than the second dielectric layer.

10. A method for forming an interconnect, the method comprising the steps of:

forming a metallic region;

forming a plasma enhanced silicon nitride (PEN) layer over the metallic region and in contact with the metallic region;

forming a first dielectric layer over the PEN layer;

forming a silicon oxynitride (SiON) layer over the first dielectric layer;

forming a second dielectric layer over the SiON layer wherein the first dielectric layer, the second dielectric layer, the PEN layer and the SiON layer forms a dielectric stack;

lithographically processing a photo-sensitive material over the second dielectric layer wherein the layers within the dielectric stack are formed to thicknesses that provide improved optical properties;

etching an interconnect trench entirely through a portion of the second dielectric layer and SiON layer and partially into the first dielectric layer using the photo-sensitive material as a masking layer where the interconnect trench is etched into a portion of the first dielectric layer so that a sidewall of the SiON layer is vertically separated from a bottom corner of the interconnect trench;

etching a via portion through a bottom portion of the first dielectric layer and the PEN layer;

16

filling both the interconnect trench and the via portion with a metallic material to form the interconnect.

11. The method of claim 10 wherein the SiON layer is silicon rich.

12. The method of claim 10 wherein the PEN layer is between 100 Angstroms and 800 in thickness, the SiON layer is between SiON 300 and 800 Angstroms in thickness, the first dielectric layer is between 3000 and 10,000 Angstroms in thickness, and the second dielectric layer is between 1500 and 14000 Angstroms in thickness.

13. The method of claim 10 wherein the SiON layer is vertically separated from a bottom corner of the interconnect trench by at least 500 Angstroms.

14. A method for forming an interconnect, the method comprising the steps of:

forming a dielectric stack having an etch stop layer comprising silicon, oxygen, and nitrogen and having a dielectric constant of approximately $\epsilon_r=7.0$,

forming a mask of photo-sensitive material over the dielectric stack;

etching an inlaid opening defined by the mask through the dielectric stack such that a sidewall of the etch stop layer is exposed but does not contact a top or bottom corner of the inlaid opening; and

filling the inlaid opening with an interconnect comprising more than 10% by volume of copper.

15. The method of claim 14 wherein the etch stop layer has a refractive index N between 1.5 and 4.0 and an extinction coefficient K between 0.00 and 1.0 at a lithographic wavelength.

16. The method of claim 14 wherein the etch stop layer has a refractive index N between 2.5 and 3.5 and an extinction coefficient K between 0.3 and 0.9 at a lithographic wavelength.

* * * * *