



US006437404B1

(12) **United States Patent**
Xiang et al.

(10) **Patent No.:** **US 6,437,404 B1**
(45) **Date of Patent:** **Aug. 20, 2002**

(54) **SEMICONDUCTOR-ON-INSULATOR TRANSISTOR WITH RECESSED SOURCE AND DRAIN**

6,064,092 A * 5/2000 Park 257/347

FOREIGN PATENT DOCUMENTS

- JP 401128514 A * 5/1989
- JP 403222454 A * 10/1991
- JP 02000150892 A * 5/2000

* cited by examiner

Primary Examiner—Olik Chaudhuri
Assistant Examiner—Hoai Pham

(74) *Attorney, Agent, or Firm*—Renner, Otto, Boisselle & Sklar, LLP

(75) **Inventors:** **Qi Xiang**, San Jose; **Wei Long**, Sunnyvale; **Ming-Ren Lin**, Cupertino, all of CA (US)

(73) **Assignee:** **Advanced Micro Devices, Inc.**, Sunnyvale, CA (US)

(*) **Notice:** Subject to any disclaimer, the term of this patent is extended or adjusted under 35 U.S.C. 154(b) by 0 days.

(57) **ABSTRACT**

A fully-depleted semiconductor-on-insulator (SOI) transistor device has an SOI substrate with a buried insulator layer having a nonuniform depth relative to a top surface of the substrate, the buried insulator layer having a shallow portion closer to the top surface than deep portions of the layer. A gate is formed on a thin semiconductor layer between the top surface and the shallow portion of the insulator layer. Source and drain regions are formed on either side of the gate, the source and drain regions each being atop one of the deep portions of the buried insulator layer. The source and drain regions thereby have a greater thickness than the thin semiconductor layer. Thick silicide regions formed in the source and drain regions have low parasitic resistance. A method of making the transistor device includes forming a dummy gate structure on an SOI substrate, and using the dummy gate structure to control the depth of an implantation to form the nonuniform depth buried insulator layer.

(21) **Appl. No.:** **09/636,239**

(22) **Filed:** **Aug. 10, 2000**

(51) **Int. Cl.⁷** **H01L 27/01**; H01L 27/12; H01L 31/0392

(52) **U.S. Cl.** **257/347**; 257/349; 257/382

(58) **Field of Search** 257/347, 349, 257/375, 382, 408; 438/149, 479, 517

(56) **References Cited**

U.S. PATENT DOCUMENTS

- 5,264,395 A 11/1993 Bindal et al.
- 5,444,282 A * 8/1995 Yamaguchi et al. 257/344
- 5,510,640 A * 4/1996 Shindo 257/347
- 5,656,844 A 8/1997 Klein et al.
- 5,930,642 A * 7/1999 Moore et al. 438/407
- 5,994,191 A 11/1999 Xiang et al.
- 6,015,752 A 1/2000 Xiang et al.

28 Claims, 5 Drawing Sheets

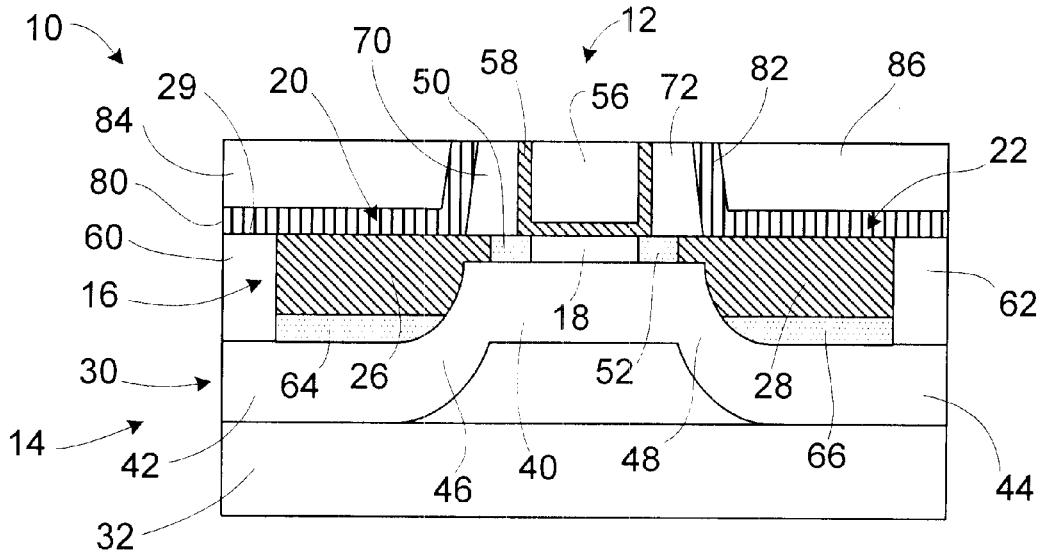

IP Bridge Exhibit 2202
TSMC v. Godo Kaisha IP Bridge 1

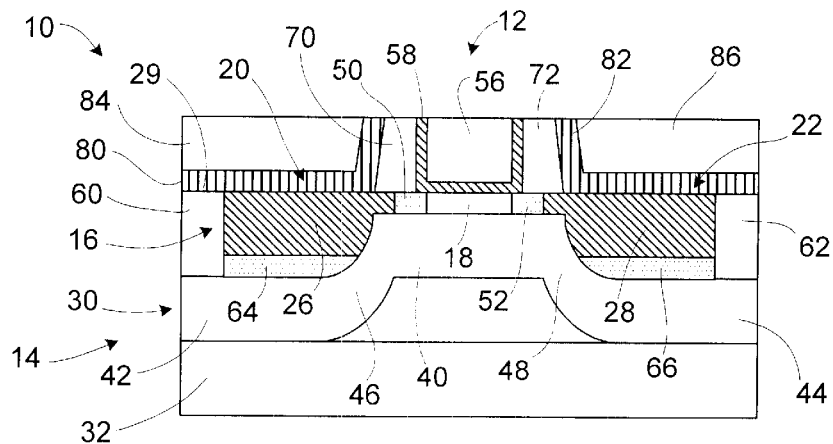

FIG. 1

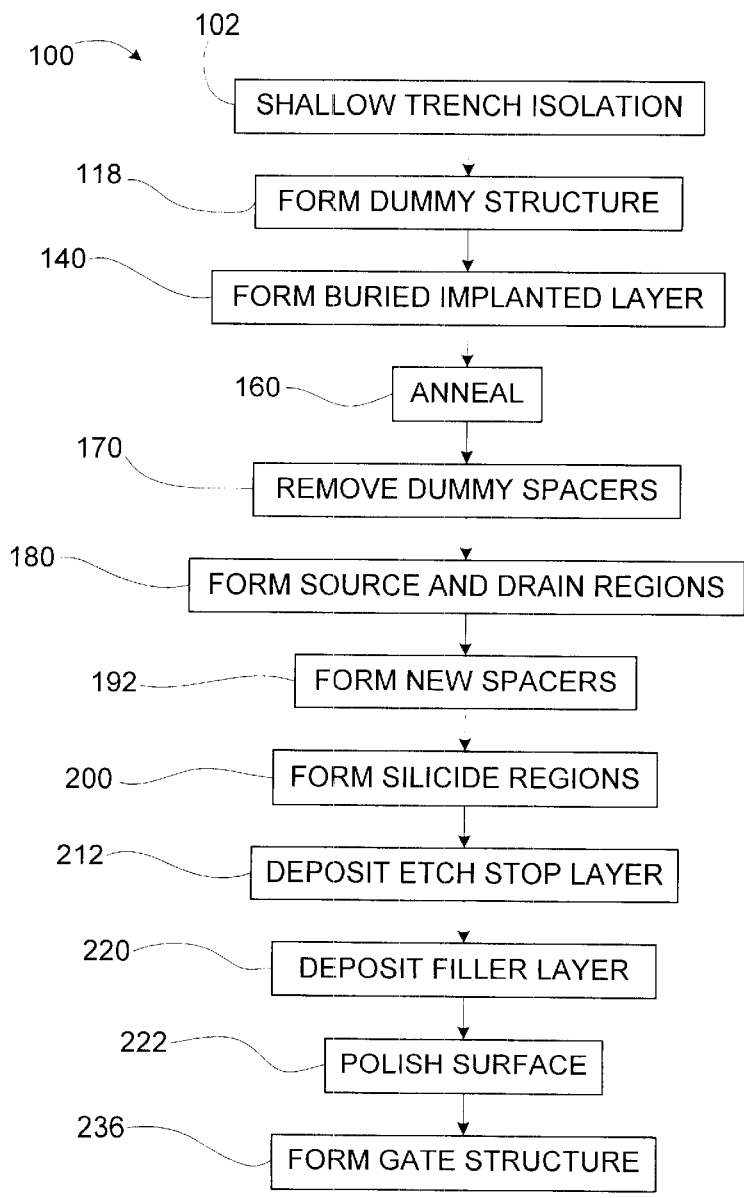

FIG. 2

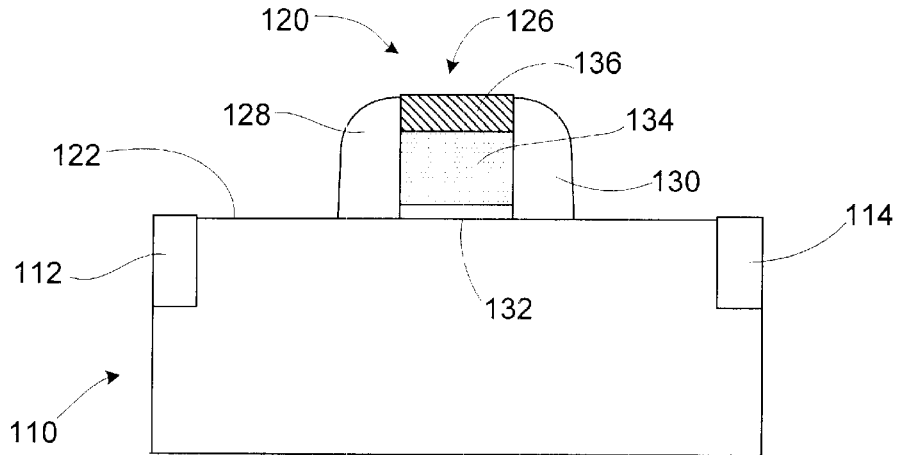

FIG. 3

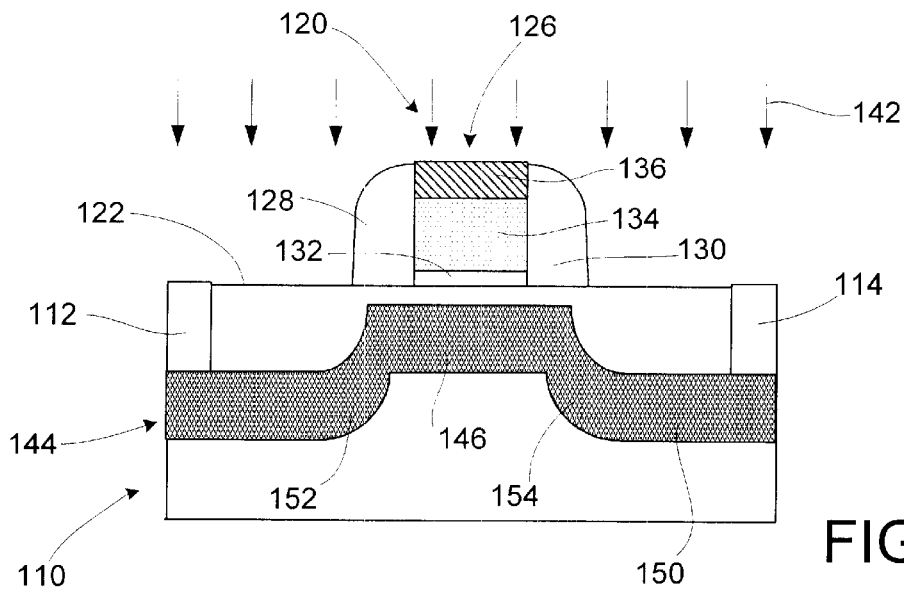

FIG. 4

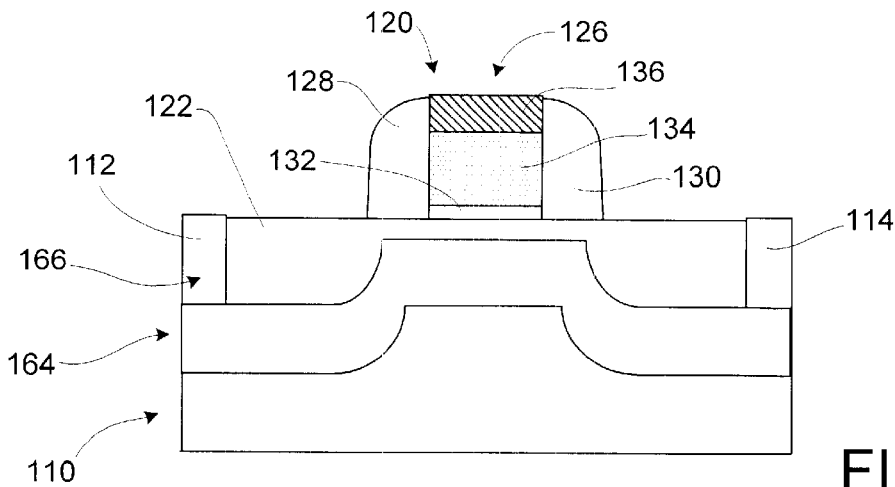

FIG. 5

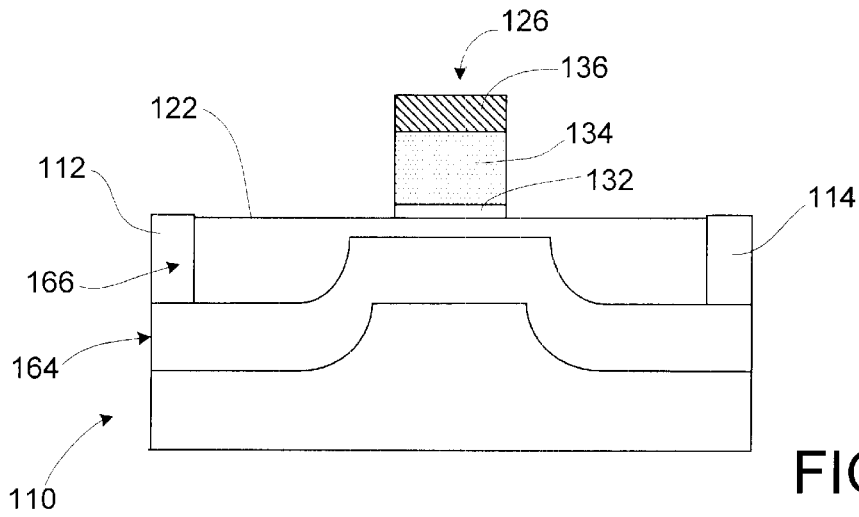

FIG. 6

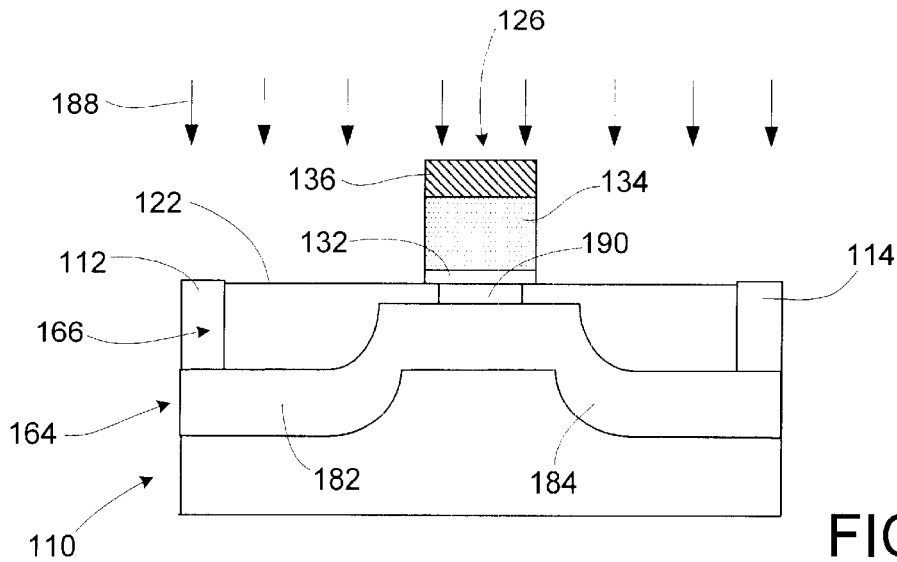

FIG. 7

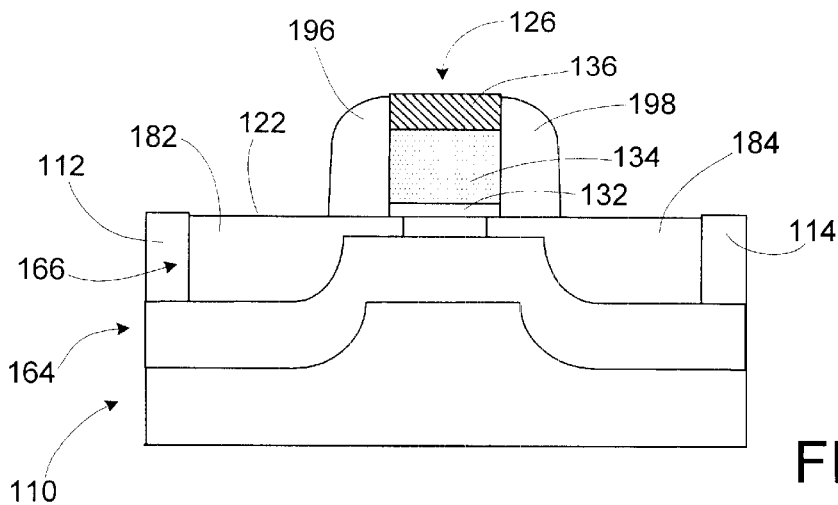

FIG. 8

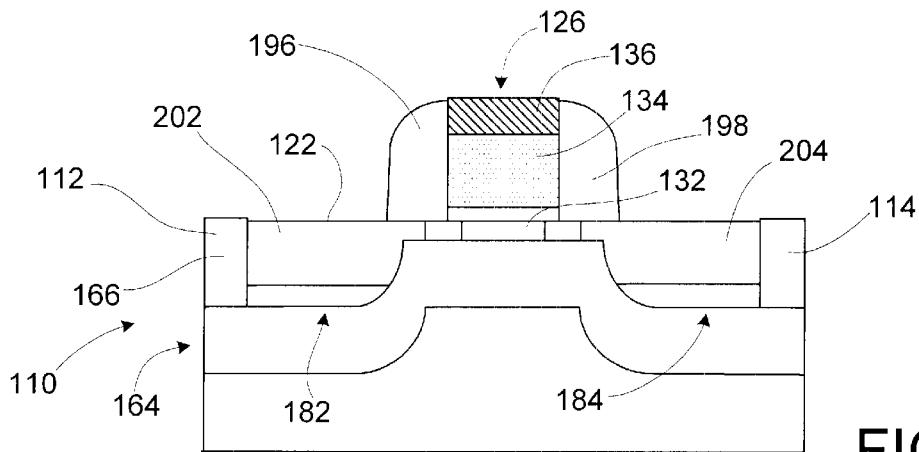

FIG. 9

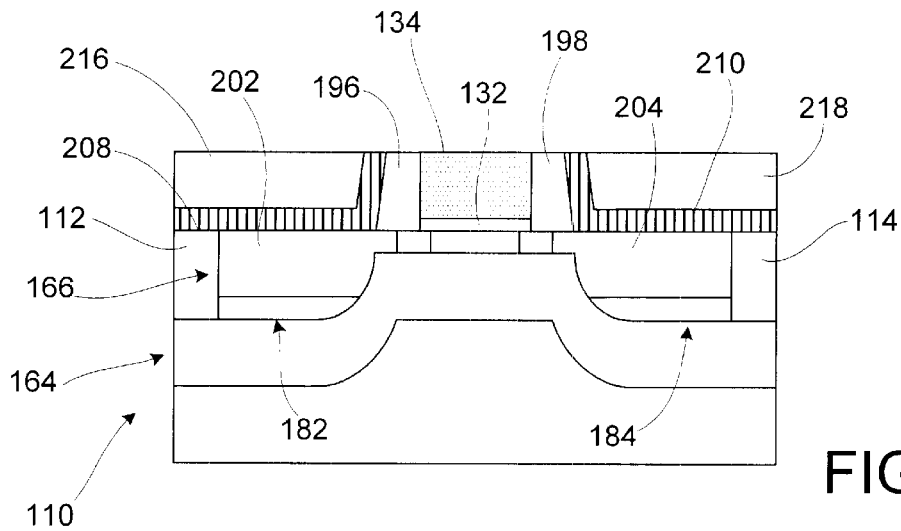

FIG. 10

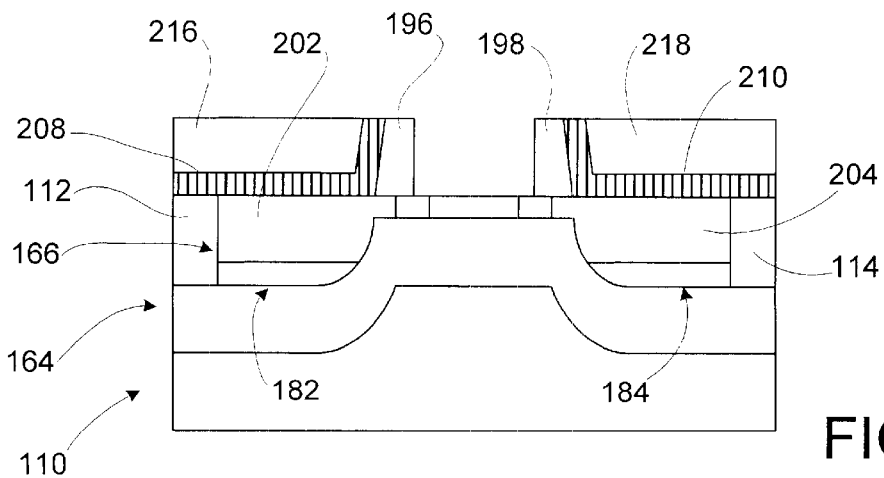

FIG. 11

Explore Litigation Insights

Docket Alarm provides insights to develop a more informed litigation strategy and the peace of mind of knowing you're on top of things.

Real-Time Litigation Alerts



Keep your litigation team up-to-date with **real-time alerts** and advanced team management tools built for the enterprise, all while greatly reducing PACER spend.

Our comprehensive service means we can handle Federal, State, and Administrative courts across the country.

Advanced Docket Research



With over 230 million records, Docket Alarm's cloud-native docket research platform finds what other services can't. Coverage includes Federal, State, plus PTAB, TTAB, ITC and NLRB decisions, all in one place.

Identify arguments that have been successful in the past with full text, pinpoint searching. Link to case law cited within any court document via Fastcase.

Analytics At Your Fingertips



Learn what happened the last time a particular judge, opposing counsel or company faced cases similar to yours.

Advanced out-of-the-box PTAB and TTAB analytics are always at your fingertips.

API

Docket Alarm offers a powerful API (application programming interface) to developers that want to integrate case filings into their apps.

LAW FIRMS

Build custom dashboards for your attorneys and clients with live data direct from the court.

Automate many repetitive legal tasks like conflict checks, document management, and marketing.

FINANCIAL INSTITUTIONS

Litigation and bankruptcy checks for companies and debtors.

E-DISCOVERY AND LEGAL VENDORS

Sync your system to PACER to automate legal marketing.