

Clinical Studies

Argininosuccinic Aciduria*

Report of Two New Cases and Demonstration of Intermittent Elevation of Blood Ammonia

HUGO W. MOSER, M.D., MARY L. EFRON, M.D., HENRY BROWN, M.D.,
RICHARD DIAMOND, A.B. and CHARLOTTE G. NEUMANN, M.D.

Boston, Massachusetts

IN 1958 Allan and associates [1] described a three and a half year old girl who had been hospitalized because of a series of generalized convulsions. They were controlled after the fourth day, but then a profound transient ataxia was noted which made it impossible for her to stand or feed herself. At that time it was also realized that she was mentally retarded (IQ 32) and had friable hair. A five year old brother had similar hair, was also mentally retarded, and had an abnormal electroencephalogram. It was shown that both sibs excreted in their urine large quantities of argininosuccinic acid [2,3], an intermediate of the Krebs-Henseleit urea cycle [4,5]. Eight other patients with argininosuccinic aciduria have since been reported [6-10].

The Krebs-Henseleit urea cycle (Fig. 1) is of great importance in human metabolism, since it represents the only known pathway for the synthesis of urea. The action of this cycle converts 2 molecules of ammonia and 1 molecule of carbon dioxide to 1 molecule each of urea and water. Four metabolic errors are known to involve enzymes of the urea cycle: (1) hyperammonemia due to a deficiency of carbamylphosphate synthetase [11]; (2) hyperammonemia due to a deficiency of ornithine transcarbamylase [12]; (3) citrullinuria, presumably due to a deficiency of argininosuccinic acid synthetase [13]; and (4) argininosuccinic aciduria.

Westall and Tomlinson [14] have demonstrated that the red blood cells of patients with argininosuccinic aciduria lack the enzyme argininosuccinase. Marked hyperammonemia has been observed in the first three of these disorders but, except for the report of Schreier and Leuchte [10], elevation of the blood ammonia level had not been described in argininosuccinic aciduria. We have found in our patients with argininosuccinic aciduria that, in the fasting state, the blood ammonia level may be normal or only slightly elevated, but that marked elevations occur postprandially or after an ammonia load. This observation suggests that hyperammonemia may be a common factor in the pathogenesis of the mental retardation associated with the four known congenital disorders of the urea cycle, and that it may be possible to improve nervous system function if increases in blood ammonia concentration can be avoided.

LABORATORY METHODS

Screening studies for amino acids were carried out by two-dimensional paper chromatography and high voltage electrophoresis [15]. Quantitative assays for amino acids were performed by column chromatography, utilizing the Technicon® Autoanalyzer system [16,17].

For the argininosuccinic acid assay, samples were acidified, boiled for 2.5 hours to convert free argininosuccinic acid to the more stable anhydrides [8], and

* From the Departments of Neurology and Surgery at Harvard Medical School, the Joseph P. Kennedy, Jr. Memorial Laboratories at the Massachusetts General Hospital, the Harvard Surgical Unit, Boston City Hospital, the Children's Developmental Clinic, Cambridge, and the Walter E. Fernald State School, Waltham, Massachusetts. This study was supported in part by U. S. Public Health Service Grants NB 02672 and NB 0506, and by U. S. Public Health Service Grant AM 4501 to the Metabolic Disease Center, at the Massachusetts General Hospital. Manuscript received March 8, 1966.

Argininosuccinic Aciduria—Moser *et al.*

FIG. 1. The Krebs-Henseleit urea cycle [4,5]. The enzymatic deficiencies in four inborn errors of metabolism are also indicated in this chart. Hyperammonemia, type 1, refers to the disorder described by Freeman *et al.* [12], type 2 to that described by Russell *et al.* [17].

then estimated by column chromatography. Ammonia levels in blood and cerebrospinal fluid were determined by a modification of the microdiffusion technic described by Conway [78,79]. Red blood cell argininosuccinase activity was measured as described by Tomlinson and Westall [14].

CASE REPORTS

P.A. This patient (MGH No. 1254845) (born July 31, 1948) was admitted to the Massachusetts General Hospital on December 2, 1963, for evaluation of mental retardation.

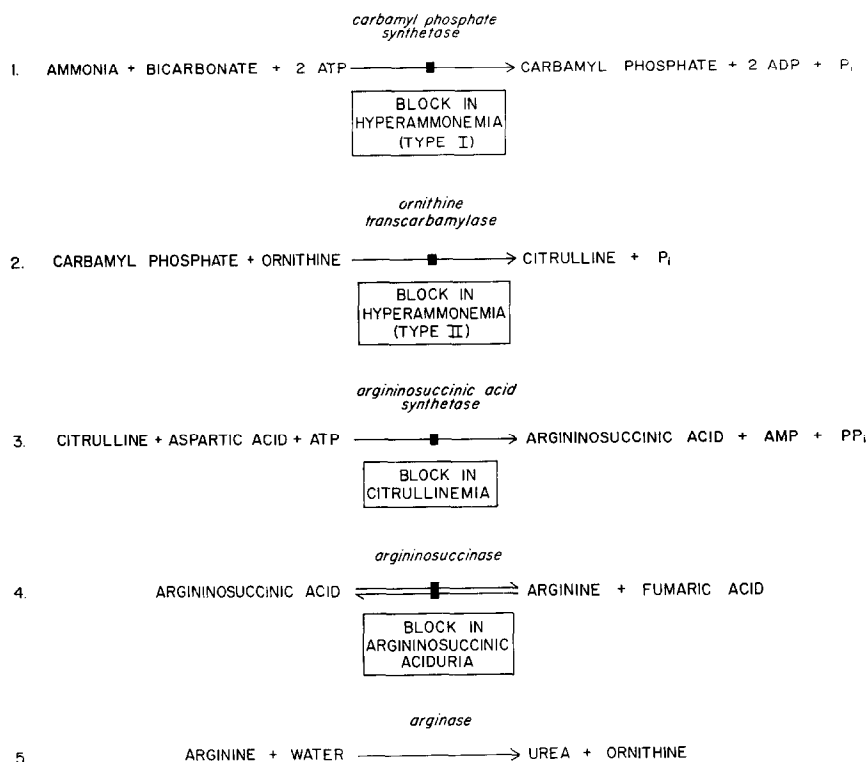
At the time of the patient's birth the mother was twenty-five years old, the father was forty-two. Gestation was nine months and birth weight almost 9 pounds. Labor and delivery were uneventful. Except for irritability, the child appeared to be in good condition in the neonatal period. At two months of age eczema developed which cleared on a diet of Mullsoy. By the time he was a year old, the child was eating solids but he disliked meat and took very little. He sat alone late and did not walk until he was well over two years old; toilet training was accomplished at two years and speech began at eighteen months.

At nine months of age he was hospitalized for bronchopneumonia, and at age fourteen months for

an upper respiratory tract infection and infected eczema. He had numerous wheezing episodes which required adrenalin injections, and he received courses of desensitization at an outpatient allergy clinic. At one and a half years of age he had a generalized tonic-clonic seizure at a time when he had a high fever. Up to the age of ten years he had two or three brief generalized seizures a year, each accompanying a high fever, but none since that time.

At six years of age he was enrolled in the first grade but was removed shortly because of poor progress. At six and a half years of age a psychometric examination was performed. He was fearful and negativistic and for this reason the results were difficult to evaluate, but it was thought that he functioned at the three to four year level. At seven years of age he was transferred to a special class for retarded children where he remained for the following eight years. He has learned to write his name but is unable to read. Since the age of ten years he has been free of respiratory tract infections and has had no further skin eruptions. He now has an excellent food intake and has lost his reluctance to eat meat. His hair has never been abnormal.

Physical examination at the age of fifteen years showed his height to be 158.4 cm. (nearly 25th per-

centile), and his weight 46.7 kg. (10th to 25th percentile). His blood pressure was 118/70 mm. Hg. The patient was a friendly boy, eager to please, but obviously limited in intelligence. Although he had a short haircut, his hair was of normal appearance, neither friable nor matted. The skin on the dorsum of the left hand was roughened, and the nails were rough and pitted; these findings were thought to be residual of the infantile eczema.

The pupils and the optic fundi were normal. The lungs were normal to percussion and auscultation, and free of wheezing. The heart was of normal size, and there was no murmur. The liver, spleen and kidneys were not palpable. The external genitalia were normal with a slight growth of pubic hair. Visual acuity and visual fields were intact. Extraocular motions were normal, and there was no nystagmus. Muscular strength and tone were normal. The triceps jerk was 2+, all other deep tendon reflexes were 1+. Plantar response was flexor. He was able to cut out pictures and paste together model toys, but performed poorly at more demanding tasks of coordination: thus he was unable to perforate the tip of a tube of liquid cement with a pin, even though he was eager to use this cement in building a toy. He was able to stand on one foot and the Romberg sign was negative, but he was unable to walk heel to toe. Otherwise, there was no abnormality of gait. Rapid repetitive movements were never performed with facility, but during these initial examinations there was no ataxia, dysmetria or intention tremor. Sensation was intact.

On the Stanford Binet Intelligence Scale L-M, performed on December 4, 1963, when he was fifteen years and four months of age, a mental age of four years and nine months was obtained, which gave an IQ in the 30's. There was limited scatter with all items passed at the fourth year level, five at the 4.6 year level, and four at the fifth year level. On the Wechsler Intelligence Scale for Children no IQ was obtained, as the score was below that for which IQ's are given. He was able to answer a few information questions and give some word meanings. He could answer the simplest comprehension questions creditably and could do one simple number problem. He could complete two of four analogies but no similarities. He was unable to understand repeating digits, either forward or backward, despite repeated demonstrations. He could detect a few details as missing from pictures. He could not understand the digit symbol substitution test despite repeated explanations. He could not assemble any puzzles or copy any block designs.

The results of the routine laboratory studies are shown in Table I. Although slight increases of alkaline phosphatase have been reported in other patients with argininosuccinic aciduria [7,6], the serum alkaline phosphatase levels of both this patient and his brother (J.A.) were within normal limits for their

TABLE I
ROUTINE LABORATORY STUDIES

Test	Patient P.A.	Patient J.A.
	Age 15-16	Age 4-5
Hemoglobin (gm./100 ml.)	13.7	11.8
White blood count (per cu. mm.)	5,500	7,000
Urinalysis—routine	Normal	Normal
Blood urea nitrogen (mg./100 ml.)	12-23	25
Fasting blood sugar (mg./100 ml.)	59, 83, 92, 96, 116	63
Protein-bound iodine (μ g./100 ml.)	5.3	6.3
Cephalin flocculation	1+	Negative
Thymol turbidity (units)	2.9	0.5-0.7
Serum total protein (gm./100 ml.)	7.9	7.0-7.1
Serum albumin (gm./100 ml.)	4.8	4.9-5.1
Serum globulin (gm./100 ml.)	3.1	1.9-2.2
Serum protein electrophoresis	Normal	Slight increase in alpha globulin
Serum bilirubin (mg./100 ml.)	0.6-1.0	0.5-1.0
Serum glutamic oxalacetic transaminase (units) (see text)	18, 30, 122, 800	23
Bromsulfalein (% retention)	Less than 1%	...
Serum cholesterol (mg./100 ml.)	200, 177	...
Serum alkaline phosphatase		
Bodansky units	12.3-13.7	13.7
Sigma units	7.1-8.1	8.1
Serum calcium (mg./100 ml.)	10.3	...
Serum phosphorus (mg./100 ml.)	5.5	...
Sodium (mEq./L.)	14.2	...
Potassium (mEq./L.)	3.8	...
Chloride (mEq./L.)	94	...
Carbon dioxide (mEq./L.)	29	...
Creatinine (mg./100 ml.)	0.8	...
Cerebrospinal fluid protein (mg./100 ml.)	15	23

age. At the time of the patient's admission in December 1963 liver function tests were within normal limits. However, on one occasion (October 31, 1963) the serum glutamic oxalacetic transaminase (SGOT) level was 800 units. The SGOT was normal on four subsequent occasions in 1963 and 1964 but was again transiently elevated to 120 units during an episode of coma associated with hyperammonemia, which will be discussed in detail.

Karyotypes of peripheral blood leukocytes showed a normal pattern. Roentgenogram of the chest was normal. Bone age was 13.5 to 14 years at a chronologic age of 15.4 years. The electroencephalogram (Fig. 2) was abnormal because the predominant electrical activity consisted of 5 to 6 per second theta waves, rather than the 8 per second alpha activity expected at this age. In addition, there were bursts of 1 to 3 per second spikes and slow waves, a pattern which is frequently found in patients who have seizures.

Clinical Summary: P.A., a fifteen year old boy with an IQ of 30 to 40, was found to have argininosuccinic aciduria when his urine was studied as part of an amino acid screening program for mentally retarded patients. Up to the age of six years, he suffered from eczema and asthmatic bronchitis. Until he was ten years old

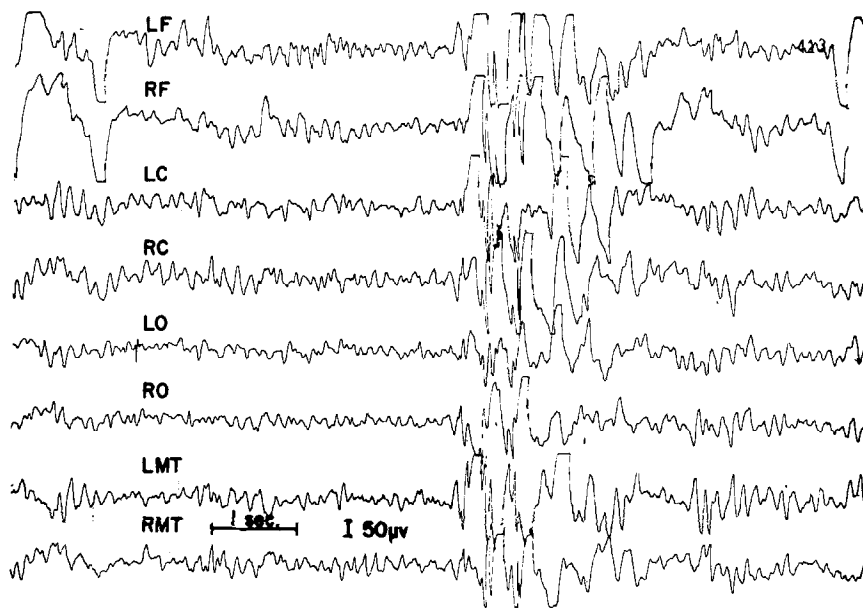

FIG. 2. Encephalogram of patient P.A. This tracing was obtained when the patient was alert and asymptomatic; the blood ammonia concentration was less than 40 μg . per cent. Abbreviations: "L" left, "R" right, "F" frontal, "C" central, "O" occipital, "MT" midtemporal. Monopolar leads were used, the reference electrode in each instance was located on the opposite ear. The left half of the figure is representative of the predominant activity observed, and shows more 5 to 7 second per theta than is normal at this age. The midportion of the figure shows a striking burst of high voltage sharp spikes and slow waves, which occur synchronously in all leads. This type of abnormality is seen frequently in patients who have seizures.

he had brief generalized seizures, up to three times yearly, each accompanying a high fever, and even now his electroencephalogram shows abnormal paroxysmal activity. There is no hair abnormality, and the findings on neurologic examination were within normal limits except for mental retardation and moderate ataxia.

J.A. This patient (MGH No. 1254846) (born December 17, 1959) was admitted to the Massachusetts General Hospital on December 2, 1963, because of delay in speech development.

At the time of his birth, his mother was thirty-seven years old and his father fifty-four. The pregnancy was uneventful. The mother went into labor spontaneously, but labor progressed poorly so that 6 hours later the fetal head was in extension and not engaged, and a cesarean section was performed. The child breathed and cried spontaneously and had good color. The birth weight was over 10 pounds. On the fourth day he was found to be unresponsive and hyperpneic, and a roentgenogram revealed pneumonia in the upper lobes. He was treated with antibiotics, and appeared entirely well six days later. He took solid food at two to three months of age and table foods by one year. Like his older brother (P.A.), he refused to eat meat.

He sat alone at nine months, stood alone and walked some time between one and a half and two and a half years. He was toilet trained by one year. At one year of age he appeared to be learning a few words but this did not continue so that, at three and a half years of age, his vocabulary was still confined to a few words such as "bird" or "goodbye" and these were pronounced indistinctly. The child had one brief, generalized convulsion when he was eighteen months old, at a time when he had a high fever.

Physical examination (age four years) showed his height to be 101.4 cm. (25th percentile) weight 18.11 kg. (75th percentile), blood pressure 100/64 mm. Hg, head circumference 54.75 cm. (75th percentile). He was an active and alert child, but without speech and unable to follow commands. His hair was light brown, curly and normal in appearance. The pupils and optic fundi were normal. The tonsils were enlarged. There was no lymphadenopathy. The lungs were normal to percussion and auscultation. The heart was normal in size and pulsation. There was a variable, grade 2 midsystolic murmur heard best along the mid left sternal border, and also at the apex. There were no palpable organs or masses in the abdomen. The external genitalia were normal.

On neurologic examination, the cranial nerves were intact. There was no nystagmus. Gait was

normal. The patient grasped objects readily with either hand, without clumsiness or tremor. The deep tendon reflexes were 1+ throughout, except for the ankle jerks which were 2+. The plantar responses were flexor. Sensation was intact for light touch and pinprick.

A cortical function test (chronologic age, four years) showed him to be alert, but it was difficult to engage and keep his attention. On the Merrill-Palmer scale, he performed at the mental age of two years and three months, so that his IQ was in the 40 to 50 range. His successes ranged from the eighteen to twenty-three month level through the thirty-six to forty-one month level, at which only one item was passed. All items were failed at the forty-two to forty-seven month level.

The results of routine laboratory studies are listed in Table 1. Karyotype preparations of peripheral blood leukocytes were normal. Roentgenograms of the skull and chest were normal. The heart was normal in size, shape and position. An electrocardiogram was normal. Bone age was two and a half to three years at a chronologic age of four years. The electroencephalogram obtained during sedated sleep was within normal limits. No seizure pattern was observed.

Clinical Summary: J.A., the four and a half year old brother of P.A., also has argininosuccinic aciduria. His IQ is estimated to be in the 40 to 50 range. He also has had a brief generalized seizure in association with high fever. He has no allergies, his hair is normal and, other than the mental retardation, the neurologic examination is within normal limits.

FAMILY HISTORY

The family tree of the A. family is shown in Figure 3. The parents are first cousins once removed, and both sides of the family originated from small villages near Messina, Sicily. The patients' parents (generation iv) both have normal intelligence, have never had convulsions, and show no abnormality on physical examination. The patient's older sister (G., generation v) graduated from high school with honor grades. No abnormalities were found on physical examination, and her urinary amino acid excretion is normal. Her infant daughter, now one year old, is developing normally, and her urine does not contain any argininosuccinic acid.

Another sister of the propoiti (T., generation v) was born on March 3, 1954, and died on October 3, 1955. Had she lived, she would have been intermediate in age between P.A. and J.A. The following data were obtained from her medical record at the Children's Medical Center in Boston (No. 43-17-15):

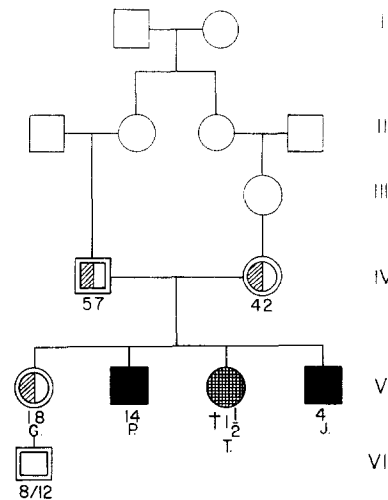

FIG. 3. The A family (argininosuccinic aciduria). Propoiti are shown as black squares. The half-shaded symbol refers to patients thought to be heterozygote, on the basis of red cell argininosuccinase assay. The cross-hatched circle refers to T.A., who died of subdural hematoma. A doubly lined circle or square refers to those who have been examined personally and are known to be normal neurologically.

“She followed with her eyes at six weeks, smiled at two months, sat up with support at three months, sat alone at eight months, stood with support at eight months, crawled at thirteen months but had not yet learned to walk. At fourteen months she began feeding poorly, became irritable, vomited on several occasions, and was admitted to the Children's Medical Center. She had an enlarged head, her neck was stiff, and there was a positive Babinski sign on the right. Subdural taps revealed dark, thick bloody fluid. At first she was treated with daily subdural taps but later a craniectomy was performed with excision of a thick subdural membrane. The day following this procedure she became decerebrate and did not recover. She died shortly after transfer to a nursing home. Postmortem examination was not permitted. Urine amino acids had not been studied.

Undoubtedly, the subdural hematoma was the cause of death. Analysis of the history and hospital records provided no evidence for any additional neurologic disease. The presence of argininosuccinic aciduria cannot be ruled out, and it must be kept in mind that in degenerative neurologic disorders there is an increased incidence of subdural hematoma.”

The patient's father (M.A.) has three sibs and the mother (E.A.) four, none of whom were available for examination. Also, no examinations could be performed on members of generations I, II or III (see Fig. 3). Careful questioning provided no evidence of mental retardation, seizures

Explore Litigation Insights

Docket Alarm provides insights to develop a more informed litigation strategy and the peace of mind of knowing you're on top of things.

Real-Time Litigation Alerts



Keep your litigation team up-to-date with **real-time alerts** and advanced team management tools built for the enterprise, all while greatly reducing PACER spend.

Our comprehensive service means we can handle Federal, State, and Administrative courts across the country.

Advanced Docket Research



With over 230 million records, Docket Alarm's cloud-native docket research platform finds what other services can't. Coverage includes Federal, State, plus PTAB, TTAB, ITC and NLRB decisions, all in one place.

Identify arguments that have been successful in the past with full text, pinpoint searching. Link to case law cited within any court document via Fastcase.

Analytics At Your Fingertips



Learn what happened the last time a particular judge, opposing counsel or company faced cases similar to yours.

Advanced out-of-the-box PTAB and TTAB analytics are always at your fingertips.

API

Docket Alarm offers a powerful API (application programming interface) to developers that want to integrate case filings into their apps.

LAW FIRMS

Build custom dashboards for your attorneys and clients with live data direct from the court.

Automate many repetitive legal tasks like conflict checks, document management, and marketing.

FINANCIAL INSTITUTIONS

Litigation and bankruptcy checks for companies and debtors.

E-DISCOVERY AND LEGAL VENDORS

Sync your system to PACER to automate legal marketing.